

# IEC Squirrel-Cage Motors

Frame sizes 56 to 450

Power range 0.06 to 1250 kW

Catalog D 81.1 · 2008



Motors

**SIEMENS**

## Related catalogs

<p><b>MOTEX Geared motors</b> D 87.1</p> <p>E86060-K5287-A111-A2-7600</p>	
<p><b>FLENDER Standard Couplings</b> MD 10.1</p> <p>E86060-K5710-A111-A2-7600</p>	
<p><b>SINAMICS G110/SINAMICS G120</b> D 11.1 Inverter Chassis Units <b>SINAMICS G120D</b> Distributed Frequency Converters</p> <p>E86060-K5511-A111-A5-7600</p>	
<p><b>SINAMICS G130</b> D 11 Drive Converter Chassis Units <b>SINAMICS G150</b> Drive Converter Cabinet Units</p> <p>E86060-K5511-A101-A4-7600</p>	
<p><b>MICROMASTER</b> DA 51.2 MICROMASTER 420/430/440 Inverters 0.12 kW to 250 kW</p> <p>E86060-K5151-A121-A6-7600</p>	
<p><b>MICROMASTER/COMBIMASTER</b> DA 51.3 MICROMASTER 411 Inverter COMBIMASTER 411 Distributed Drive Solutions</p> <p>E86060-K5251-A131-A2-7600</p>	
<p><b>Industrial Communication</b> IK PI Part 5: ET 200 Distributed I/O ET 200S FC Frequency converter</p> <p>E86060-K6710-A101-B6-7600</p>	
<p><b>AC NEMA &amp; IEC Motors</b> D 81.2 Further details available on the Internet at: U.S./ Canada</p> <p>Only PDF <a href="http://www.sea.siemens.com/motors">http://www.sea.siemens.com/motors</a></p>	
<p><b>Industry Automation and Motion Control</b> CA 01 The Offline-Mall (DVD)</p> <p>E86060-D4001-A510-C7-7600</p>	

### Industry Automation and Motion Control

Information and ordering platform on the Internet at:

[www.siemens.com/automation/mall](http://www.siemens.com/automation/mall)



#### Additional documentation

You will find all information material, such as brochures, catalogs, manuals and operating instructions for standard drive systems up-to-date on the Internet at the address

<http://www.siemens.com/motors/printmaterial>

You can order the listed documentation or download it in common file formats (PDF, ZIP).

#### Catalog CA 01 – Selection tool SD configurator

The selection tool **SD configurator** is available in combination with the electronic catalog CA 01 on DVD.



Furthermore, the SD configurator can now be used on the Internet without installation.

The SD configurator can be found in the Siemens Mall under the following address:

<http://www.siemens.com/sd-configurator>

In the main menu of the CA 01 under the tab "selection tool", you will find the SD configurators for low-voltage motors, MICROMASTER 4 inverters, SINAMICS G110 and SINAMICS G120 inverter chassis units as well as SINAMICS G120D distributed frequency converters and SIMATIC ET 200S FC and SIMATIC ET 200pro FC frequency converters for distributed I/O, complete with:

- Dimension drawing generator for motors
- Data sheet generator for motors and inverters
- Starting calculation
- 3D models in .stp format
- Extensive documentation

#### Hardware and software requirements

- PC with 1.5 GHz CPU or faster
- Operating systems
  - Windows 98/ME
  - Windows 2000
  - Windows XP
  - Windows NT (Service Pack 6 or higher)
  - Windows Vista
- 1024 MB work memory (minimum)
- Screen resolution 1024 x 768, graphic with more than 256 colors
- Small fonts
- CD-ROM drive
- Windows-compatible sound card
- Windows-compatible mouse

#### Installation

You can install this catalog directly from the DVD as a partial version or full version on your hard disk or in the network.

# Motors

## IEC Squirrel-Cage Motors

Frame sizes 56 to 450

Power range 0.06 to 1250 kW

Catalog D 81.1 · 2008



The products and systems described in this catalog are manufactured/distributed under application of a certified quality management system in accordance with DIN EN ISO 9001 (Certified Registration No. DE-000357 QM). The certificate is recognized by all IQNet countries.

Supersedes:

Catalog D 81.1 · 2007

Catalog News D 81.1 N · October 2007

The products contained in this catalog can also be found in the e-Catalog CA 01.

Order No.:

E86060-D4001-A510-C7-7600 (DVD)

Please contact  
your local  
Siemens branch

© Siemens AG 2008

Introduction	0
New Generation 1LE1/1PC1	1
Standard motors up to frame size 315 L	2
Non-standard motors frame size 315 and above	3
Explosion-proof motors	4
Motors operating with frequency converters	5
Pump motors	6
Fan motors	7
Compressor motors	8
Smoke-extraction motors	9
Marine motors	10
Appendix	11





## Answers for Industry.

Siemens Industry answers the challenges in the manufacturing and the process industry as well as in the building automation business. Our drive and automation solutions based on Totally Integrated Automation (TIA) and Totally Integrated Power (TIP) are employed in all kinds of industry. In the manufacturing and the process industry. In industrial as well as in functional buildings.

Siemens offers automation, drive, and low-voltage switching technology as well as industrial software from standard products up to entire industry solutions. The industry software enables our industry customers to optimize the entire value chain – from product design and development through manufacture and sales up to after-sales service. Our electrical and mechanical components offer integrated technologies for the entire drive train – from couplings to gear units, from motors to control and drive solutions for all engineering industries. Our technology platform TIP offers robust solutions for power distribution.

The high quality of our products sets industry-wide benchmarks. High environmental aims are part of our eco-management, and we implement these aims consistently. Right from product design, possible effects on the environment are examined. Hence many of our products and systems are RoHS compliant (Restriction of Hazardous Substances). As a matter of course, our production sites are certified according to DIN EN ISO 14001, but to us, environmental protection also means most efficient utilization of valuable resources. The best example are our energy-efficient drives with energy savings up to 60 %.

Check out the opportunities our automation and drive solutions provide. And discover how you can sustainably enhance your competitive edge with us.

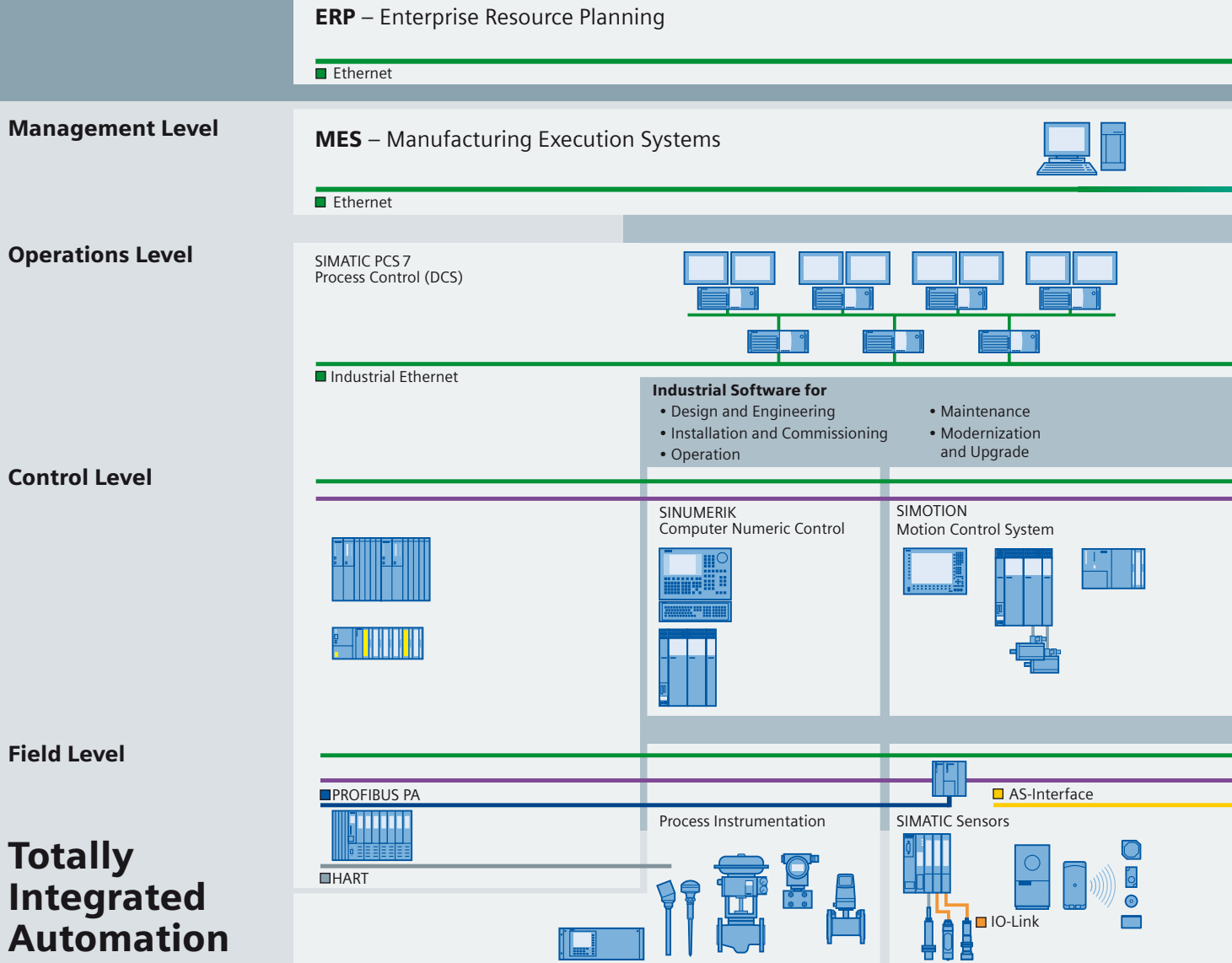

# Setting standards in productivity and competitiveness.

**Totally Integrated Automation.**

Thanks to Totally Integrated Automation, Siemens is the only provider of an integrated basis for implementation of customized automation solutions – in all industries from inbound to outbound.

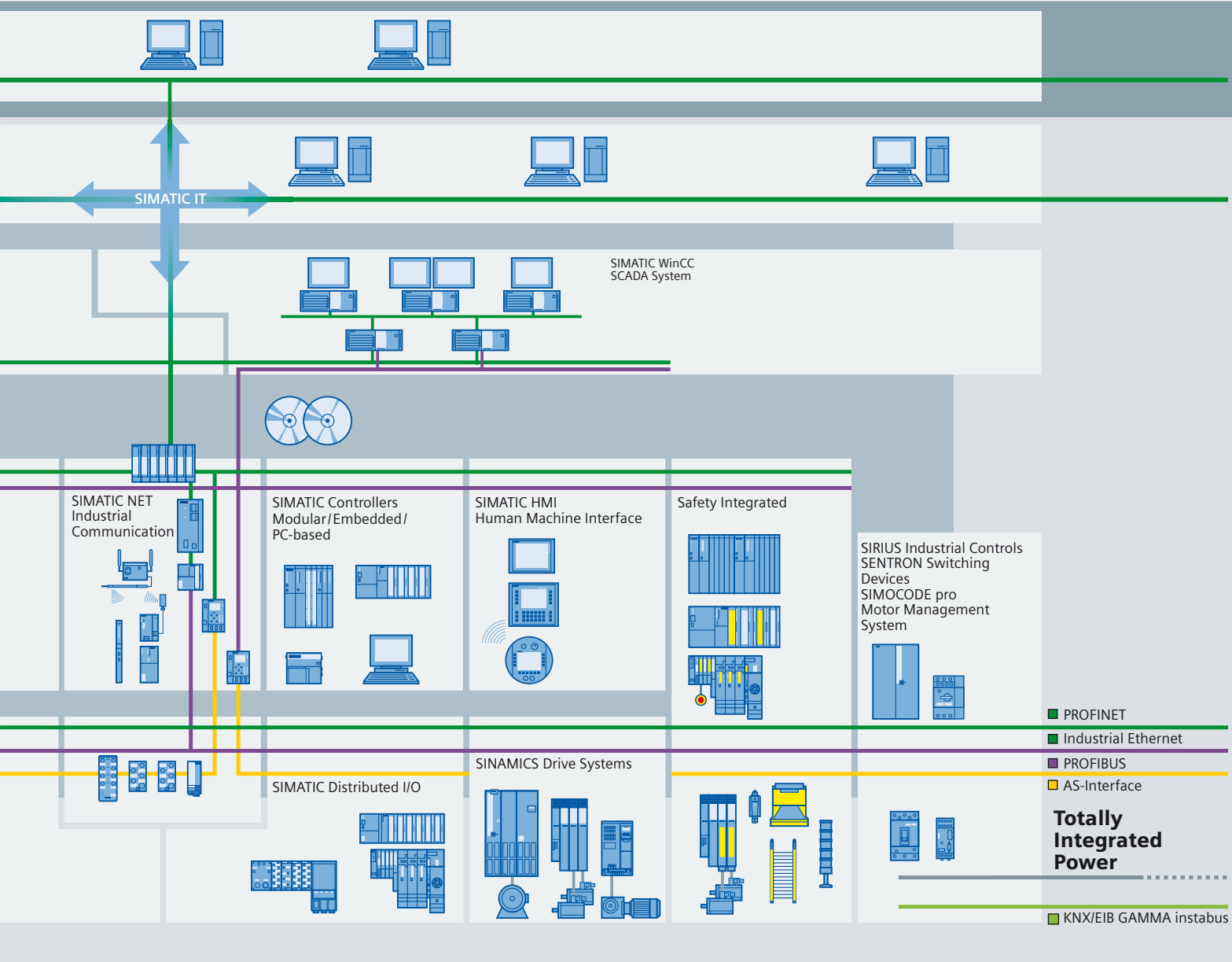

### TIA is characterized by its unique continuity.

It provides maximum transparency at all levels with reduced interfacing requirements – covering the field level, production control level, up to the corporate management level. With TIA you also profit throughout the complete life cycle of your plant – starting with the initial planning steps through operation up to modernization, where we offer a high measure of investment security resulting from continuity in the further development of our products and from reducing the number of interfaces to a minimum.

### The unique continuity is already a defined characteristic at the development stage of our products and systems.

The result: maximum interoperability – covering the controller, HMI, drives, up to the process control system. This reduces the complexity of the automation solution in your plant. You will experience this, for example, in the engineering phase of the automation solution in the form of reduced time requirements and cost, or during operation using the continuous diagnostics facilities of Totally Integrated Automation for increasing the availability of your plant.



## Integrated power distribution from one source.

**Totally Integrated Power.**



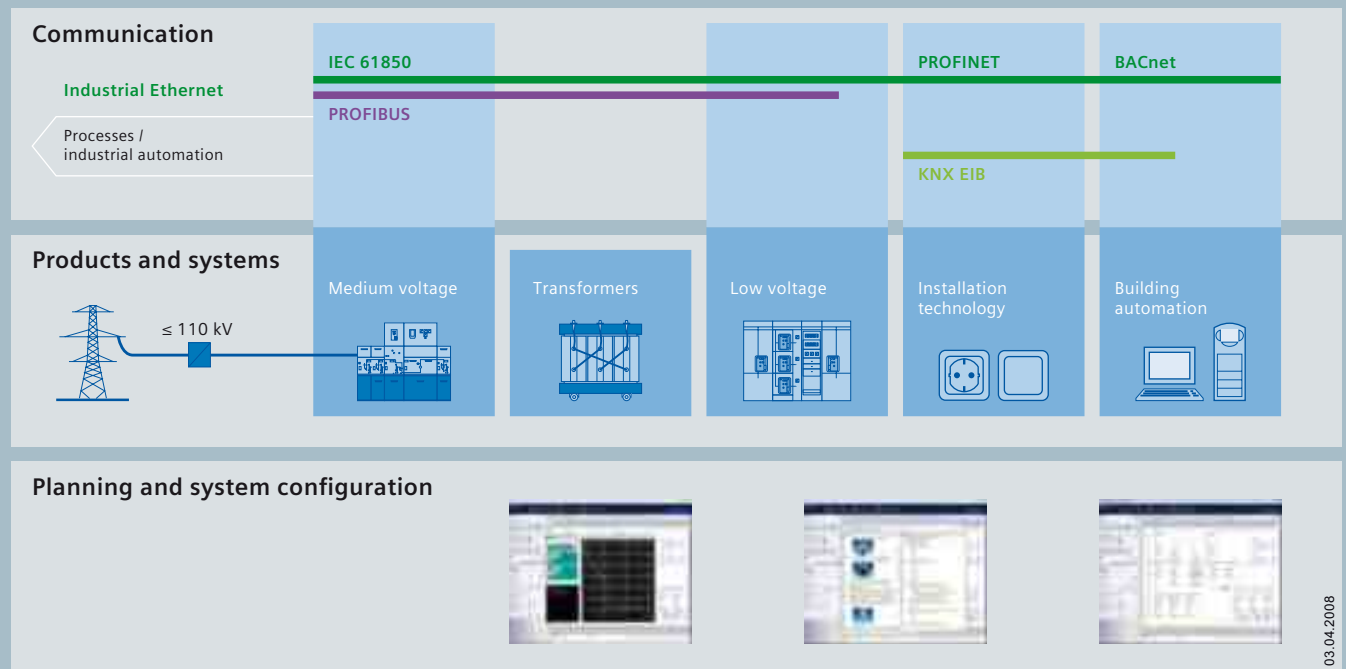

Electrical power distribution in buildings requires integrated solutions. Our response: Totally Integrated Power. This means innovative and integrated, interface-optimized products and systems which have been optimally coordinated and complemented with communication and software modules that link power distribution to building automation or industrial automation. Totally Integrated Power accompanies power distribution projects from one end to the other. From A to Z. From the planning to the building's use: Totally Integrated Power offers significant advantages in every project stage and to everyone involved in the project – the investors, electrical planning engineers, electricians, users and building facility managers.

Our portfolio comprises everything from engineering tools to the matching hardware: from switchgear and distribution systems for medium voltage to transformers, from switching and circuit-protection devices to low-voltage switchgear and busbar trunking systems, as far as to the small distribution board and the wall outlet. It goes without saying that both the medium-voltage switchgear, which requires no maintenance, and the low-voltage switchgear are type-tested, and their busbar connections, too. Comprehensive protection systems ensure the safety of man and machine at any time.



# Introduction



## 0/2 Guide to selecting and ordering the motors

0/2 Overview

- 0/2 • Recommendations for drive selection – step-by-step to the required motor
- 0/3 • Determining the motor type according to cooling method, degree of protection and frame design

### Introduction motors 1LA, 1LG, 1LL, 1LP, 1MA, 1MJ, 1PP, 1PQ

#### 0/7 Order No. code

0/7 Overview

#### 0/8 Special versions

0/8 Overview

#### 0/13 General technical data

0/13 Overview

- 0/13 • Cut-away diagram of a low-voltage motor
- 0/14 • Designs in accordance with standards and specifications
- 0/17 • Colors and paint finish
- 0/20 • Packaging, safety notes, documentation and test certificates
- 0/22 • Voltages, currents and frequencies
- 0/28 • Outputs
- 0/29 • Efficiency, power factor, rated torque, rated speed and direction of rotation
- 0/30 • Rating plate and extra rating plates
- 0/31 • Coolant temperature and site altitude
- 0/32 • Windings and insulation
- 0/34 • Motor protection
- 0/36 • Heating and ventilation
- 0/38 • Motor connection and connection box
- 0/52 • Types of construction
- 0/54 • Mechanical design and degrees of protection
- 0/56 • Balance and vibration quantity
- 0/56 • Shaft and rotor
- 0/58 • Bearings and lubrication
- 0/75 • Modular technology
  - 0/75 – 1XP8 001 rotary pulse encoder
  - 0/76 – Separately driven fan
  - 0/77 – Brakes
  - 0/84 – Combinations of basic versions
- 0/85 • Special technology

### Introduction motors 1LE1/1PC1

#### 0/94 Order No. code

0/94 Overview

#### 0/95 Special versions

0/95 Overview

#### 0/97 General technical data

0/97 Overview

- 0/97 • Cut-away diagram of a low-voltage motor
- 0/98 • Designs in accordance with standards and specifications
- 0/100 • Colors and paint finish
- 0/102 • Packaging, safety notes, documentation and test certificates
- 0/103 • Voltages, currents and frequencies
- 0/105 • Outputs
- 0/105 • Efficiency, power factor, rated torque, rated speed and direction of rotation
- 0/106 • Rating plate and extra rating plates
- 0/107 • Coolant temperature and site altitude
- 0/108 • Windings and insulation
- 0/110 • Motor protection
- 0/111 • Heating and ventilation
- 0/113 • Motor connection and connection box
- 0/116 • Types of construction
- 0/118 • Mechanical design and degrees of protection
- 0/120 • Balance and vibration quantity
- 0/121 • Shaft and rotor
- 0/122 • Bearings and lubrication
- 0/127 • Modular technology
  - 0/128 – 1XP8 012 rotary pulse encoder
  - 0/129 – Separately driven fan
  - 0/130 – Brakes
- 0/134 • Special technology

# IEC Squirrel-Cage Motors

## Introduction

### Guide to selecting and ordering the motors

0

#### Overview

These “recommendations for drive selection” guide you step-by-step through this catalog to the required motor.

Step 1	Technical requirements for the motor		
<b>Determine the required product profile, the following are required:</b>	Rated frequency and rated voltage	3 AC 50/60 Hz, 400, 500 or 690 V	
	Duty	Standard duty (continuous duty S1 according to DIN EN 60034-1)	
	Degree of protection or type of explosion protection required	IP..	
	Rated speed (No. of poles)	$n = \dots\dots\dots$ rpm	
	Rated output	$P = \dots\dots\dots$ kW	
	Rated torque	$M = P \cdot 9550/n = \dots\dots\dots$ Nm	
	Type of construction	IM..	
Step 2	Environmental requirements for the motor		
<b>Determine the installation conditions</b>	Ambient temperature	$\leq 40$ °C	>40 °C
	Site altitude	$\leq 1000$ m	>1000 m
	Factors for derating	None	Determine the factor for derating (for derating factor, see “Technical information” – “Coolant temperature and site altitude”)
Step 3	For preliminary selection of the motor, $\Rightarrow$ see subsequent pages and the corresponding “Preliminary selection of the motor” tables in the different catalog parts		
<b>Determine the range of possible motors</b>	Select the frame size and therefore the possible motors on the basis of the following parameters: cooling method, degree of protection, rated output, rated speed and rated torque range. Note: The standard temperature range of the motors is from $-20$ to $+40$ °C.		
Step 4	Detailed selection of the motor		
<b>Determine the basic Order No. of the motor</b>	Determine the motor Order No. according to the following parameters: rated output, rated speed, rated torque and rated current from the “Selection and ordering data” for the motors that have already been identified as possibilities.		
Step 5	Selection of the special versions (see under “Special versions”)		
<b>Complete the motor Order No.</b>	Determine special versions and the associated order codes (e. g. special voltages and types of construction, motor protection and degrees of protection, windings and insulation, colors and paint finish, mountings and technology, etc.) .		
Step 6			
<b>Select the frequency converter, if required</b>	For Order No. of the converter as well as its selection, see Catalogs D 11, D 11.1 , DA 51.2 and DA 51.3.		

#### Note on using this catalog

Due to the wide range of possible versions of low-voltage motors, the special features of the various motor series are not explained in detail in each case in this catalog part. The availability of individual technical designs can be established from catalog parts 1 to 10.

# IEC Squirrel-Cage Motors

## Introduction

### Guide to selecting and ordering the motors

0

**Determine the motor type according to cooling method, degree of protection and frame design**  
(for further selection according to speed or number of poles, rated output, rated torque, rated speed and rated current, see the relevant "Preselection of the motor" tables in catalog parts 1 to 10)

Applications for surface-cooled motor types	Cooling method	Standard designation for degree of protection to DIN EN 60034 Part 5	Frame design	Motor type (Positions 1 to 3 of the Order No.) + type series (Position 4 of the Order No.) Rated output at 50 Hz		Motor frame sizes (shaft heights)														
				56	63	71	80	90	100	112	132	160	180	200	225	250	280	315	355	400
<b>New generation motors 1LE1/1PC1</b>				<b>Catalog Part 1</b>																
General Line motors with shorter delivery time	Self-ventilated	IP55	Aluminum	1LE1 1.5 ... 18.5 kW																
Energy-saving motors with improved efficiency (Improved Efficiency EFF2)	Self-ventilated	IP55	Aluminum	1LE1 0.75 ... 18.5 kW																
Energy-saving motors with high efficiency (High Efficiency EFF1)	Self-ventilated	IP55	Aluminum	1LE1 0.75 ... 18.5 kW																
Motors with increased output and improved efficiency	Self-ventilated	IP55	Aluminum	1LE1 2.2 ... 22 kW																
Motors with increased output and high efficiency	Self-ventilated	IP55	Aluminum	1LE1 2.2 ... 22 kW																
Motors without external fan and fan cover with improved efficiency	Forced-air-cooled	IP55	Aluminum	1LE1 0.75 ... 18.5 kW																
Motors without external fan and fan cover with high efficiency	Forced-air-cooled	IP55	Aluminum	1LE1 0.75 ... 18.5 kW																
Motors without external fan and fan cover with improved efficiency	Self-cooled	IP55	Aluminum	1PC1 0.3 ... 7.4 kW																
Motors without external fan and fan cover with high efficiency	Self-cooled	IP55	Aluminum	1PC1 0.37 ... 9 kW																
<b>Standard motors (up to frame size 315 L)</b>				<b>Catalog Part 2</b>																
Energy-saving motors with improved efficiency (Improved Efficiency EFF 2)	Self-ventilated	IP55	Aluminum	1LA7 0.06 ... 18.5 kW	1LE1/1PC1	1LA5 11 ... 45 kW														
		IP55	Cast iron		1LA6 0.75 ... 18.5 kW	1LG4 11 ... 200 kW														
Pole-changing motors with improved efficiency	Self-ventilated	IP55	Aluminum	1LA7 0.15 ... 17 kW		1LA5 18 ... 31 kW														
Energy-saving motors with high efficiency (High Efficiency EFF1)	Self-ventilated	IP55	Aluminum	1LA9 0.06 ... 37 kW																
		IP55	Cast iron			1LG6 11 ... 200 kW														
Motors with increased output	Self-ventilated	IP55	Aluminum	1LA9 0.14 ... 53 kW																
		IP55	Cast iron			1LG4 15 ... 110 kW														
Motors without external fans	Self-cooled	IP55	Aluminum	1LP7 0.045 ... 7 kW	1LE1/1PC1	1LP5 5.5 ... 16.5 kW														
		IP55	Cast iron			1LP4 3.7 ... 67 kW														
<b>Non-standard motors (frame size 315 and above)</b>				<b>Catalog Part 3</b>																
Motors for mains-fed operation	Self-ventilated	IP55	Cast iron				1LA8 160 ... 1000 kW													
Motors for converter-fed operation	Self-ventilated	IP55	Cast iron				1LA8 145 ... 1000 kW													
Motors with mounted separately driven fan for converter-fed operation	Forced-air-cooled	IP55	Cast iron				1PQ8 145 ... 1000 kW													
Motors with through-ventilation for mains-fed operation	Self-ventilated	IP23	Cast iron				1LL8 200 ... 1250 kW													
Motors with through-ventilation for converter-fed operation	Self-ventilated	IP23	Cast iron				1LL8 200 ... 1250 kW													

# IEC Squirrel-Cage Motors

## Introduction

### Guide to selecting and ordering the motors

0

Determining the motor type according to cooling method, degree of protection and frame design (continued)

Applications for surface-cooled motor types	Cooling method	Standard designation for degree of protection to DIN EN 60034 Part 5	Frame design	Motor type (Positions 1 to 3 of the Order No.) + type series (Position 4 of the Order No.) Rated output at 50 Hz	Motor frame sizes (shaft heights)																	
					56	63	71	80	90	100	112	132	160	180	200	225	250	280	315	355	400	450
<b>Explosion-proof motors</b>					<b>Catalog Part 4</b>																	
Motors in Zone 1 with type of protection "e" (Zone 1 Exe II T3)	Self-ventilated	IP55	Aluminum	<b>1MA7</b> 0.12 ... 16 kW																		
			Cast iron		<b>1MA6</b> 1.3 ... 165 kW																	
Motors in Zone 1 with type of protection "de" (Zone 1 Exde IIC T4)	Self-ventilated	IP55	Cast iron	<b>1MJ6</b> 0.25 ... 37 kW															<b>1MJ7</b> 18.5 ... 132 kW			
Motors in Zone 2 with type of protection "n"	Self-ventilated	IP55	Aluminum	<b>1LA7</b> 0.09 ... 18.5 kW																		
			Aluminum	<b>1LA9</b> 0.06 ... 37 kW																		
			Cast iron		<b>1LA6</b> 0.75 ... 18.5 kW																<b>1LG4/1LG6</b> 11 ... 200 kW	
																				<b>1LA8</b> 145 ... 1000 kW		
Motors in Zone 21 with explosion protection	Self-ventilated	IP65	Aluminum	<b>1LA7</b> 0.09 ... 18.5 kW																<b>1LA5</b> 11 ... 45 kW		
			Aluminum	<b>1LA9</b> 0.06 ... 37 kW																		
			Cast iron																		<b>1LG4/1LG6</b> 11 ... 200 kW	
Motors in Zone 22 with explosion protection	Self-ventilated	IP55	Aluminum	<b>1LA7</b> 0.09 ... 18.5 kW																<b>1LA5</b> 11 ... 45 kW		
			Aluminum	<b>1LA9</b> 0.06 ... 37 kW																		
			Cast iron		<b>1LA6</b> 0.75 ... 18.5 kW																<b>1LG4/1LG6</b> 11 ... 200 kW	
																				<b>1LA8</b> 145 ... 1000 kW		
<b>Motors operating with frequency converters</b>					<b>Catalog Part 5</b>																	
Surface-cooled motors with standard insulation for voltages ≤500 V																						
For standard motors, non-standard motors, explosion-proof motors and fan motors, see catalog part 5.																						
Motors with special insulation for voltages up to 690 V (standard motors)	Self-ventilated	IP55	Aluminum	<b>1LA7</b> 1.5 ... 18.5 kW																<b>1LA5</b> 15 ... 45 kW		
			Cast iron																		<b>1LG6</b> 11 ... 200 kW	
Motors with special insulation for voltages up to 690 V (non-standard motors)	Self-ventilated	IP55	Cast iron																		<b>1LA8</b> 145 ... 980 kW	
Motors with mounted separately driven fan with special insulation for voltages up to 690 V	Forced-air cooled	IP55	Cast iron																		<b>1PQ8</b> 145 ... 980 kW	

# IEC Squirrel-Cage Motors

## Introduction

### Guide to selecting and ordering the motors

0

**Determining the motor type according to cooling method, degree of protection and frame design (continued)**

Applications for surface-cooled motor types	Cooling method	Standard designation for degree of protection to DIN EN 60034 Part 5	Frame design	Motor type (Positions 1 to 3 of the Order No.) + type series (Position 4 of the Order No.) Rated output at 50 Hz		Motor frame sizes (shaft heights)																	
				56	63	71	80	90	100	112	132	160	180	200	225	250	280	315	355	400	450		
<b>Pump motors</b>																						<b>Catalog Part 6</b>	
Energy-saving motors with improved efficiency (Improved Efficiency EFF2)	Self-ventilated	IP55	Aluminum	<b>1LA7</b> 0.06 ... 18.5 kW		<b>1LE1/1PC1</b>		<b>1LA5</b> 11 ... 45 kW															
			Cast iron			<b>1LA6</b> 0.75 ... 18.5 kW		<b>1LG4</b> 11 ... 200 kW															
Motors with increased output	Self-ventilated	IP55	Aluminum	<b>1LA9</b> 0.14 ... 53 kW																			
			Cast iron			<b>1LG4</b> 15 ... 110 kW																	
<b>Fan motors</b>																						<b>Catalog Part 7</b>	
Motors in pole-changing version	Self-ventilated	IP55	Aluminum	<b>1LA7</b> 0.15 ... 17 kW		<b>1LA5</b> 18 ... 31 kW																	
			Cast iron			<b>1LG4</b> 4.5 ... 175 kW																	
Motors without external fan and without fan cover	Forced-air cooled	IP55	Aluminum	<b>1PP7</b> 0.09 ... 18.5 kW		<b>1LE1/1PC1</b>		<b>1PP5</b> 11 ... 37 kW															
			Cast iron					<b>1PP4</b> 11 ... 200 kW															
<b>Compressor motors</b>																						<b>Catalog Part 8</b>	
Energy-saving motors with high efficiency	Self-ventilated	IP55	Aluminum	<b>1LA9</b> 0.06 ... 37 kW																			
			Cast iron			<b>1LG6</b> 11 ... 200 kW																	
Motors with increased output	Self-ventilated	IP55	Aluminum	<b>1LA9</b> 0.14 ... 53 kW																			
			Cast iron			<b>1LG4</b> 15 ... 110 kW																	
Non-standard motor for mains-fed and converter-fed operation	Self-ventilated	IP55	Cast iron													<b>1LA8</b> 160 ... 1000 kW							
<b>Smoke extraction motors</b>																						<b>Catalog Part 9</b>	
Temperature/time class F200, F300	Self-ventilated	IP55	Aluminum	<b>1LA7</b> 0.37 ... 18.5 kW (0.09 ... 3.85 kW pole-changing)		<b>1LA5</b> 15 ... 45 kW (4.05 ... 8.6 kW pole-changing)																	
			Cast iron					<b>1LG6</b> 37 ... 200 kW															
	Forced-air cooled	IP55	Aluminum	<b>1PP7</b> 0.37 ... 18.5 kW (0.09 ... 3.85 kW pole-changing)		<b>1PP5</b> 15 ... 45 kW (4.05 ... 8.6 kW pole-changing)																	
			Cast iron					<b>1PP6</b> 37 ... 200 kW															
Temperature/time class F400	Self-ventilated	IP55	Cast iron	<b>1LA6</b> 1.5 ... 18.5 kW (0.3 ... 3.45 kW pole-changing)		<b>1LG6</b> 15 ... 200 kW																	
	Forced-air cooled	IP55	Cast iron	<b>1PP6</b> 1.5 ... 200 kW (0.3 ... 3.45 kW pole-changing)																			
<b>Marine motors (motors for drives on ships below deck)</b>																						<b>Catalog Part 10</b>	
Type approved standard motors up to frame size 315 L – Energy-saving motors with improved efficiency (Improved Efficiency EFF2)	Self-ventilated	IP55	Aluminum	<b>1LA7</b> 0.06 ... 18.5 kW		<b>1LA5</b> 11 ... 45 kW																	
			Cast iron			<b>1LA6</b> 0.75 ... 18.5 kW		<b>1LG4</b> 11 ... 200 kW															
Type approved standard motors up to frame size 315 L – Energy-saving motors with high efficiency (High Efficiency EFF1)	Self-ventilated	IP55	Aluminum	<b>1LA9</b> 0.06 ... 37 kW																			
			Cast iron			<b>1LG6</b> 11 ... 200 kW																	
Type approved, explosion-proof motors up to frame size 315 L – Motors in Zone 1 with type of protection "e" (Zone 1 Exe II T3)	Self-ventilated	IP55	Aluminum	<b>1MA7</b> 0.12 ... 16 kW																			
			Cast iron			<b>1MA6</b> 1.3 ... 165																	

# IEC Squirrel-Cage Motors

## Introduction

### Guide to selecting and ordering the motors

0

Determining the motor type according to cooling method, degree of protection and frame design (continued)

Applications for surface-cooled motor types	Cooling method	Standard designation for degree of protection to DIN EN 60034 Part 5	Frame design	Motor type (Positions 1 to 3 of the Order No.) + type series (Position 4 of the Order No.) Rated output at 50 Hz																	
				Motor frame sizes (shaft heights)																	
				56	63	71	80	90	100	112	132	160	180	200	225	250	280	315	355	400	450
<b>Catalog Part 10</b>																					
<b>Marine motors (motors for drives on ships below deck) (continue)</b>																					
Type approved, explosion-proof motors up to frame size 315 L – Motors in Zone 1 with type of protection “de” (Zone 1 Exde IIC T4)	Self-ventilated	IP55	Cast iron	1MJ6 0.25 ... 37 kW				1MJ7 18.5 ... 132 kW													
Type approved, explosion-proof motors up to frame size 315 L – Motors in Zone 2 with type of protection “n”	Self-ventilated	IP55	Aluminum	1LA7 0.09 -18.5 kW																	
		IP55	Aluminum	1LA9 0.06 ... 37 kW																	
		IP55	Cast iron	1LA6 0.75 ... 18.5 kW				1LG4/1LG6 11 ... 200 kW													
Explosion-proof motors up to frame size 315 L – Motors in Zone 21 with protection against dust explosions	Self-ventilated	IP55	Aluminum	1LA7 0.09 ... 18.5 kW				1LA5 11 ... 45 kW													
		IP55	Aluminum	1LA9 0.06 ... 37 kW																	
		IP55	Cast iron					1LG4/1LG6 11 ... 200 kW													
Explosion-proof motors up to frame size 315 L – Motors in Zone 22 with protection against dust explosions	Self-ventilated	IP55	Aluminum	1LA7 0.09 ... 18.5 kW				1LA5 11 ... 45 kW													
		IP55	Aluminum	1LA9 0.06 ... 37 kW																	
		IP55	Cast iron	1LA6 0.75 ... 18.5 kW				1LG4/1LG6 11 ... 200 kW													
Type approved fan motors – Motors in pole-changing version	Self-ventilated	IP55	Aluminum	1LA7 0.15 ... 17 kW				1LA5 18 ... 31 kW													
		IP55	Cast iron					1LG4 4.5 ... 83 kW													
Type approved fan motors – Motors without external fan and without fan cover	Forced-air cooled	IP55	Aluminum	1PP7 0.09 ... 18.5 kW				1PP5 15 ... 37 kW													
		IP55	Cast iron					1PP4 11 ... 200 kW													
Standard motors up to frame size 315 L	Self-cooled	IP55	Aluminum	1LP7 0.045 ... 7 kW				1LP5 5.5 ... 16.5 kW													
		IP55	Cast iron					1LP4 3.7 ... 67 kW													
Smoke-extraction motors Temperature/time classes F200 and F300	Self-ventilated	IP55	Aluminum	1LA7 0.09 ... 18.5 kW				1LA5 4.05 ... 45 kW													
		IP55	Cast iron					1LG6 37 ... 200 kW													
	Forced-air cooled	IP55	Aluminum	1PP7 0.09 ... 18.5 kW				1PP5 4.05 ... 45 kW													
		IP55	Cast iron									1PP6 37 ... 200 kW									
Smoke-extraction motors Temperature/time class F400	Self-ventilated	IP55	Cast iron	1LA6 0.3 ... 22 kW				1LG6 15 ... 200 kW													
	Forced-air cooled	IP55	Cast iron	1PP6 0.3...200 kW																	
Non-standard motor frame size 315 and above – Motors for mains-fed and converter-fed operation	Self-ventilated	IP55	Cast iron	1LA8 145 ... 1000 kW																	
Non-standard motors frame size 315 and above – Forced-air cooled motors with mounted separately driven fan for converter-fed operation	Forced-air cooled	IP55	Cast iron	1PQ8 145 ... 1000 kW																	
Non-standard motors frame size 315 and above – Self-ventilated motors with through-ventilation for mains-fed and converter-fed operation	Self-ventilated	IP23	Cast iron	1LL8 180 ... 1250 kW																	
Non-standard motors frame size 315 and above – Water-cooled motors for mains-fed and converter-fed operation	Forced-air cooled	IP55	Steel	1) 1)																	
Explosion-proof motors frame size 315 and above – Self-ventilated motors in Zones 2, 22 with type of protection “n” or protection against dust explosions	Self-ventilated	IP55	Cast iron	1LA8 160 ... 1000 kW																	

1) 1LH8 motor frame size 450, rated output 485 ... 1150 kW



# IEC Squirrel-Cage Motors

## Introduction motors 1LA, 1LG, 1LL, 1LP, 1MA, 1MJ, 1PP, 1PQ

Order No. code

0

### Overview

The Order No. comprises a combination of letters and numbers and for clarity it is subdivided into two blocks which are connected by hyphens,

e. g.

**1LA5223-4AA19-Z**

**M1F + A11 + G17**

The first block (positions 1 to 7) identifies the motor type; further characteristics of the version are coded in the second block (positions 8 to 12).

For deviations in the second block from the catalog codes, either **-Z** or **9** should be used as appropriate.

#### Ordering data:

- Complete Order No. and order code(s) or plain text.
- If a quotation has been requested, please specify the quotation number in addition to the Order No.
- When ordering a complete motor as a spare part, please specify the works serial No. for the previously supplied motor as well as the Order No.

Structure of the Order No.:		Position:	1	2	3	4	5	6	7	-	8	9	10	11	12	
<b>IEC squirrel-cage motors, surface-cooled</b>																
<b>Positions 1 to 3:</b> Digit, letter, letter	<ul style="list-style-type: none"> <li>• Self-ventilated by fan mounted on and driven by rotor, aluminum or cast-iron housing</li> <li>• Self-ventilated by fan mounted on and driven by rotor, cast-iron housing</li> <li>• Self-ventilated by fan mounted on and driven by rotor, increased safety, type of protection Ex e II</li> <li>• Self-ventilated by fan mounted on and driven by rotor, explosion-proof enclosure, type of protection Ex de IIC</li> <li>• Self-ventilated with through-ventilation, cast-iron housing</li> <li>• Self-cooled without external fan, aluminum and cast-iron housing</li> <li>• Forced-air cooled by air flow from the fan to be driven, aluminum or cast-iron housing</li> <li>• Forced-air cooled by separately driven fan, cast-iron housing</li> </ul>	1	L	A												
<b>Position 4:</b> Digit	Type series 4 Type series 5 Type series 6 Type series 7 Type series 8 Type series 9					4 5 6 7 8 9										
<b>Positions 5 to 7:</b> 3 digits	Motor frame size (frame size comprising shaft height and construction length, codes from 050 to 457)															
<b>Position 8:</b> Digit	Number of poles															
<b>Positions 9 to 10:</b> Letter	Version															
<b>Position 11:</b> Digit	Voltage, circuit and frequency															
<b>Position 12:</b> Digit	Type of construction															
	Special order versions: Coded – Order code also required Not coded – Plain text also required															- Z

### Ordering example

Selection criteria	Requirement	Structure of the Order No.
Motor type	Standard motor with improved efficiency, IP55 degree of protection, aluminum housing	<b>1LA5□□□-□□□□□</b>
Motor frame size/No. of poles/speed	4-pole/1500 rpm	<b>1LA5223-4AA□□</b>
Rated output	45 kW	<b>1LA5223-4AA1□</b>
Voltage and frequency	230 VΔ/400 VY, 50 Hz	<b>1LA5223-4AA19</b>
Type of construction	IM V5 with protective cover	<b>M1F</b>
Special versions	3 PTC thermistors	<b>1LA5223-4AA19-Z</b> <b>M1F A11</b>
	Mounted separately driven fan	<b>1LA5223-4AA19-Z</b> <b>M1F A11 G17</b>

# IEC Squirrel-Cage Motors

## Introduction motors 1LA, 1LG, 1LL, 1LP, 1MA, 1MJ, 1PP, 1PQ

### Special versions

0

#### Overview

The order codes and availability are assigned to the individual motor series in the "Selection and ordering data" in the individual catalog parts 2 to 10.

For voltages, see "Voltages, currents and frequencies" in the "Introduction" as well as in catalog parts 2 to 10.

For types of construction, see "Types of construction" in the "Introduction" as well as in catalog parts 2 to 10.

All available options are listed according to topics in the following table. An alphanumerical listing according to order codes can be found in the appendix under "Overview of order codes".

Order code	Special versions	For further information, see Page
<b>Motor protection</b>		
A10	With PTC thermistors for alarm for converter-fed operation in Zones 2, 21, 22	0/33, 4/82
A11	Motor protection through PTC thermistor with 3 embedded temperature sensors for tripping	0/34, 0/38
A12	Motor protection through PTC thermistor with 6 embedded temperature sensors for tripping and alarm	0/35
A15	Motor protection with PTC thermistors for converter-fed operation with 3 or 4 embedded temperature sensors for tripping	0/35, 4/3, 4/82
A16	Motor protection with PTC thermistors for converter-fed operation with 6 or 8 embedded temperature sensors for alarm and tripping	0/33, 4/3, 4/82
A23	Motor temperature detection with embedded temperature sensor KTY 84-130	0/35
A25	Motor temperature detection with embedded temperature sensors 2 x KTY 84-130	0/35
A31	Temperature detectors for tripping	0/34
A60	Installation of 3 PT 100 resistance thermometers in stator winding	0/36
A61	Installation of 6 PT 100 resistance thermometers in stator winding	0/36
A72	Installation of 2 PT 100 screw-in resistance thermometers (basic circuit) for rolling-contact bearings	0/36
A78	Installation of 2 PT 100 screw-in resistance thermometers (3-wire circuit) for rolling-contact bearings	0/36
A80	Installation of 2 PT 100 double screw-in resistance thermometers (3-wire circuit) for rolling-contact bearings	0/36
<b>Motor connection and connection box</b>		
G55	ECOFAST motor plug Han-Drive 10e for 230 VΔ/400 VY	0/51
G56	ECOFAST motor plug EMC Han-Drive 10e for 230 VΔ/400 VY	0/51
K06	Two-part plate on connection box	0/39
K09	Connection box on RHS	0/38
K10	Connection box on LHS	0/38
K11	Connection box on top, feet screwed on	0/38
K15	Connection box in cast-iron version	0/38, 0/47 ...
K53	Explosion-proof connection box, Ex d IIC type of protection	0/38, 0/48 ...
K54	One cable gland, metal	0/39
K55	Cable gland, maximum configuration	0/39
K57	Cable gland DIN 89280, maximum configuration	0/39
K83	Rotation of the connection box through 90°, entry from DE	0/39
K84	Rotation of the connection box through 90°, entry from NDE	0/39
K85	Rotation of connection box through 180°	0/39
L00	Next larger connection box	0/38
L01	Undrilled entry plate	0/40
L13	External earthing	0/38
L44	3 cables protruding, 0.5 m long	0/40
L45	3 cables protruding, 1.5 m long	0/40
L47	6 cables protruding, 0.5 m long	0/40
L48	6 cables protruding, 1.5 m long	0/40
L49	6 cables protruding, 3 m long	0/40
L51	Protruding cable ends – right side	0/40
L52	Protruding cable ends – left side	0/40
L97	Auxiliary connection box 1XB3 020	0/50
M46	Stud terminal for cable connection, accessories pack (3 items)	0/49
M47	Saddle terminal for connection without cable lug, accessories pack	0/49
M50	Auxiliary connection box 1XB9 016	0/50
M58	Next larger connection box 1XB1 621	0/38
M64	Connection box on NDE	0/38
M69	Terminal strip for main and auxiliary terminals	0/49
M88	Auxiliary connection box 1XB9 014 (aluminum)	0/50
<b>Windings and insulation</b>		
C11	Temperature class 155 (F), used acc. to 155 (F), with service factor (SF)	0/32
C12	Temperature class 155 (F), used acc. to 155 (F), with increased power rating	0/32
C13	Temperature class 155 (F), used acc. to 155 (F), with increased coolant temperature	0/33
C18	Temperature class 180 (H) at rated output and max. CT 60 °C	0/33
C19	Increased air humidity/temperature with 30 to 60 g water per m <sup>3</sup> of air	0/33

# IEC Squirrel-Cage Motors

## Introduction motors 1LA, 1LG, 1LL, 1LP, 1MA, 1MJ, 1PP, 1PQ

Special versions

0

**Overview** (continued)

Order code	Special versions	For further information, see Page
<b>Windings and insulation (continued)</b>		
C22	Temperature class 155 (F), used acc. to 130 (B), coolant temperature 45 °C, derating approx. 4 %	0/33
C23	Temperature class 155 (F), used acc. to 130 (B), coolant temperature 50 °C, derating approx. 8 %	0/33
C24	Temperature class 155 (F), used acc. to 130 (B), coolant temperature 55 °C, derating approx. 13 %	0/33
C25	Temperature class 155 (F), used acc. to 130 (B), coolant temperature 60 °C, derating approx. 18 %	0/33
C26	Increased air humidity/temperature with 60 to 100 g water per m <sup>3</sup> of air	0/33
Y50	<i>New!</i> Temperature class 155 (F), used acc. to 130 (B), with increased coolant temperature and/or site altitude	0/33
Y52	Temperature class 155 (F), used acc. to 155 (F), other requirements	0/33
<b>Colors and paint finish</b>		
K23	Unpainted (only cast-iron parts primed)	0/17
K24	Unpainted, only primed	0/17
K26	Special finish in RAL 7030 stone gray	0/18
M91	<i>New!</i> Offshore special finish	0/17
M94	<i>New!</i> Sea air resistant special finish	0/17
Y51	Special finish in special RAL colors	0/17, 0/19
Y53	Standard finish in other standard RAL colors	0/17, 0/18
Y54	Special finish in other standard RAL colors	0/17, 0/18
<b>Modular technology – Basic versions</b>		
G17	Mounting of separately driven fan	0/76
G26	Mounting of brake	0/77 ...
H57	Mounting of 1XP8 001-1 (HTL) rotary pulse encoder	0/75
H58	Mounting of 1XP8 001-2 (TTL) rotary pulse encoder	0/75
<b>Modular technology – Combinations of basic versions</b>		
H61	Mounting of separately driven fan and 1XP8 001-1 rotary pulse encoder	0/84
H62	Mounting of brake and 1XP8 001-1 rotary pulse encoder	0/84
H63	Mounting of brake and separately driven fan	0/84
H64	Mounting of brake, separately driven fan and 1XP8 001-1 rotary pulse encoder	0/84
H97	Mounting of separately driven fan and 1XP8 001-2 rotary pulse encoder	0/84
H98	Mounting of brake and 1XP8 001-2 rotary pulse encoder	0/84
H99	Mounting of brake, separately driven fan and 1XP8 001-2 rotary pulse encoder	0/84
<b>Modular technology – Additional versions</b>		
C00	Brake supply voltage 24 V DC	0/83
C01	Brake supply voltage 400 V AC	0/83
C02	Brake supply voltage 180 V DC, for operation on MM411-ECOFAST	0/83
K82	Manual brake release with lever	0/83
<b>Special technology</b>		
H15	Prepared for mounting MMI	0/15, 0/85
H47	Mounting of brake NFA (Stomag)	0/85
H70	Mounting of LL 861 900 220 rotary pulse encoder	0/85
H72	Mounting of HOG 9 D 1024 I rotary pulse encoder	0/86
H73	Mounting of HOG 10 D 1024 I rotary pulse encoder	0/87
H78	Prepared for mounting LL 861 900 220	0/85
H79	Prepared for mounting HOG 9 D 1024 I	0/86
H80	Prepared for mounting HOG 10 D 1024 I	0/87
H86	<i>New!</i> Mounting of explosion-proof rotary pulse encoder for use in Zones 2, 21, 22	4/5, 4/6
H87	<i>New!</i> Mounting of explosion-proof rotary pulse encoder for use on Ex d/de motors in Zone 1	4/5, 4/6
J15	<i>New!</i> Mounting of explosion-proof rotary pulse encoder HOG 10 DN 1024 I, connection box protection against moisture	0/87
J16	<i>New!</i> Mounting of explosion-proof rotary pulse encoder HOG 10 DN 1024 I, connection box protection against dust	0/88
M95	<i>New!</i> Mounting of explosion-proof separately driven fan Ex nA for use in Zone 2	4/5, 4/8
M96	<i>New!</i> Mounting of explosion-proof separately driven fan II 2D for use in Zone 21	4/5, 4/8
M97	<i>New!</i> Mounting of explosion-proof separately driven fan II 3D for use in Zone 22	4/5, 4/8
M98	<i>New!</i> Mounting of explosion-proof separately driven fan Ex de for use in Zone 1	4/5, 4/8
Y70	Mounting a special type of rotary pulse encoder	0/85
Y74	<i>New!</i> Mounting of rotary pulse encoder HOG 10 DN 1024 I + FSL, (speed .... rpm), connection box protection against moisture	0/88
Y76	<i>New!</i> Mounting of rotary pulse encoder HOG 10 DN 1024 I + FSL, (speed .... rpm), connection box protection against dust	0/89
Y79	<i>New!</i> Mounting of rotary pulse encoder HOG 10 DN 1024 I + E SL 93, (speed .... rpm), connection box protection against moisture	0/89

# IEC Squirrel-Cage Motors

## Introduction motors 1LA, 1LG, 1LL, 1LP, 1MA, 1MJ, 1PP, 1PQ

### Special versions

#### Overview (continued)

Order code	Special versions	For further information, see Page
<b>Mechanical design and degrees of protection</b>		
K17	Drive-end seal for flange-mounting motors with oil resistance to 0.1 bar	0/54
K32	With two additional eyebolts for IM V1/IM V3	0/54
K37	Low-noise version for 2-pole motors with clockwise direction of rotation	0/55
K38	Low-noise version for 2-pole motors with counter-clockwise direction of rotation	0/55
K50	IP65 degree of protection	0/54
K52	IP56 degree of protection (non-heavy-sea)	0/54
L03	Vibration-proof version	0/55
L12	Condensation drainage holes	0/54
M27	Non-rusting screws (externally)	0/55
M44	Earth brushes for converter-fed operation	0/55
M68	Mechanical protection for encoder	0/55
<b>Coolant temperature and site altitude</b>		
D02	Coolant temperature -50 to +40 °C	0/32
D03	Coolant temperature -40 to +40 °C	0/32
D04	Coolant temperature -30 to +40 °C	0/32
D11	Coolant temperature 45 °C, derating 4 %	0/32
D12	Coolant temperature 50 °C, derating 8 %	0/32
D13	Coolant temperature 55 °C, derating 13 %	0/32
D14	Coolant temperature 60 °C, derating 18 %	0/32
D19 <i>New!</i>	Coolant temperature -40 °C to +40 °C for EX motor	4/5
<b>Designs in accordance with standards and specifications</b>		
D01	CCC China Compulsory Certification	0/16
D30	Electrical according to NEMA MG1-12	0/15
D31	Design according to UL with "Recognition Mark"	0/15
D32	Ex certification for China	4/83
D33 <i>New!</i>	Certified for Korea according to KS C4202	0/16
D40	Canadian regulations (CSA)	0/15, 0/16
D46 <i>New!</i>	PSE Mark Japan	0/16
<b>Design for Zones 1, 2, 21 and 22 according to ATEX</b>		
C27	Stamping of Ex nA II on VIK rating plate	4/83
C30	Outputs T1/T2 on rating plate	4/81
K30	VIK design (comprises Zone 2 for mains-fed operation, without Ex nA II marking on rating plate)	4/83
M34	Design for Zone 21, as well as Zone 22 for conducting dust (IP65) for mains-fed operation	4/4, 4/81
M35	Design for Zone 22 for non-conducting dust (IP55) for mains-fed operation	4/4, 4/81
M38	Design for Zone 21, as well as Zone 22 for conducting dust (IP65) for converter-fed operation, derating	4/4, 4/83
M39	Design for Zone 22 for non-conducting dust (IP55) for converter-fed operation, derating	4/4, 4/83
M72	Design for Zone 2 for mains-fed operation Ex nA II T3 to IEC/EN 60079-15	4/4, 4/81 ...
M73	Design for Zone 2 for converter-fed operation, derating Ex nA II T3 to IEC/EN 60079-15	4/4, 4/83
M74 <i>New!</i>	Design for Zones 2 and 22, for non-conducting dust (IP55), for mains-fed operation	4/81
M75 <i>New!</i>	Design for Zones 2 and 22, for non-conducting dust (IP55), for converter-fed operation, derating	4/83
M76 <i>New!</i>	Design for Zones 1 and 21, as well as for Zone 22 for conducting dust (IP65), for mains-fed operation	4/81
M77 <i>New!</i>	Design for Zones 1 and 21, as well as for Zone 22 for conducting dust (IP65), for converter-fed operation, derating	4/82
Y68	Alternative converter (SIMOVERT MASTERDRIVES, SINAMICS G110, SINAMICS S120 or ET 200 S FC)	4/82
<b>Marine version – Basic marine version</b>		
E00	Without type test certificate according to ABS 50 °C/CCS 45 °C/RINA 45 °C, temperature class 155 (F), used according to 155 (F)	10/4 ...
E11	With/without type test certificate according to GL (Germanischer Lloyd), Germany, CT 45 °C, temperature class 155 (F), used according to 155 (F)	10/4 ...
E21	With/without type test certificate according to LR (Lloyds Register), Great Britain, CT 45 °C, temperature class 155 (F), used according to 155 (F)	10/4 ...
E31	With/without type test certificate according to BV (Bureau Veritas), France, CT 45 °C, temperature class 155 (F), used according to 155 (F)	10/4 ...
E51	With/without type test certificate according to DNV (Det Norske Veritas), Norway, CT 45 °C, temperature class 155 (F), used according to 155 (F)	10/4 ...
E61	With/without type test certificate according to ABS (American Bureau of Shipping), USA, CT 50 °C, temperature class 155 (F), used according to 155 (F)	10/4 ...
E71	With/without type test certificate according to CCS (Chinese Classification Society), China, CT 45 °C, temperature class 155 (F), used according to 155 (F)	10/4 ...
E80	Motor for use in shipping, higher ambient temperature and/or used as 155 (F) according to 130 (B)	10/10 ...

# IEC Squirrel-Cage Motors

## Introduction motors 1LA, 1LG, 1LL, 1LP, 1MA, 1MJ, 1PP, 1PQ

Special versions

0

**Overview** (continued)

Order code	Special versions	For further information, see Page
<b>Marine version – Acceptance/certification</b>		
E09	Individual acceptance by marine classification society with supervision of construction and acceptance test certificate 3.2 according to EN 10204	10/4 ...
E10	Individual acceptance by marine classification society	10/4 ...
F83	Type test with heat run for horizontal motors, with acceptance	10/6 ...
F93	Type test with heat run for vertical motors, with acceptance	10/23 ...
<b>Standardline (only for motor series 1LA8)</b>		
B20	Standardline version	3/13
<b>Bearings and lubrication</b>		
G50	Measuring nipple for SPM shock pulse measurement for bearing inspection	0/58
K20	Bearing design for increased cantilever forces	0/58, 0/62 ...
K36	Special bearing for DE and NDE, bearing size 63	0/58, 0/63 ...
K40	Regreasing device	0/58
K94	Located bearing DE	0/58
L04	Located bearing NDE	0/58
L27	Insulated bearing cartridge	0/58
<b>Balance and vibration quantity</b>		
K02	Vibration quantity level B	0/56
L68	Full key balancing	0/56
M37	<i>New!</i> Balancing without key	0/56
<b>Shaft and rotor</b>		
K04	Concentricity of shaft extension, coaxiality and linear movement in accordance with DIN 42955 Tolerance R for flange-mounting motors	0/57
K16	Second standard shaft extension	0/56
K42	Shaft extension with standard dimensions, without featherkey way	0/57
L39	Concentricity of shaft extension in accordance with DIN 42955 Tolerance R	0/57
M65	Standard shaft made of non-rusting steel	0/57
Y55	Non-standard cylindrical shaft extension	0/57
<b>Heating and ventilation</b>		
H17	Fan cover for textile industry	0/37
K34	Cast-iron fan cover	0/37
K35	Metal external fan	0/37
K45	Anti-condensation heaters for 230 V	0/36
K46	Anti-condensation heaters for 115 V	0/36
L36	Sheet metal fan cover	0/37
M14	<i>New!</i> Anti-condensation heater, Ex. 115 V	0/36
M15	<i>New!</i> Anti-condensation heater, Ex. 230 V	0/36
Y81	Separately driven fan with non-standard voltage and/or frequency	0/37
<b>Rating plate and extra rating plates</b>		
B06	<i>New!</i> Second lubricating plate, supplied loose	0/30
K31	Second rating plate, loose	0/30
Y80	Extra rating plate or rating plate with deviating rating plate data	0/30
Y82	Extra rating plate with identification code	0/30
Y84	Additional information on rating plate and on package label (maximum of 20 characters)	0/30
<b>Packaging, safety notes, documentation and test certificates</b>		
B00	Without safety and commissioning note. Customer's declaration of renouncement required.	0/21
B01	Complete with one set of safety and commissioning notes per wire-lattice pallet	0/21
B02	Acceptance test certificate 3.1 according to EN 10204	0/21
B23	Operating instructions German/English enclosed in print	0/21
B31	Document – Electrical data sheet	0/21, 3/52 ...
B32	Document – Order dimension drawing	0/21, 3/52 ...
B37	Document – Load characteristics	0/21, 3/52 ...
F01	Standard test (routine test) with acceptance	0/21, 3/52 ...
F03	Visual acceptance and report handover with acceptance	0/21, 3/52 ...
F04	Temperature-rise test, without acceptance	0/21, 3/53 ...
F05	Temperature-rise test, with acceptance	0/21, 3/53 ...
F28	Noise measurement during idling, no noise analysis, no acceptance	0/21, 3/53 ...
F29	Noise measurement during idling, no noise analysis, with acceptance	0/21, 3/53 ...

# IEC Squirrel-Cage Motors

## Introduction motors 1LA, 1LG, 1LL, 1LP, 1MA, 1MJ, 1PP, 1PQ

### Special versions

0

#### Overview *(continued)*

Order code	Special versions	For further information, see Page
<b>Packaging, safety notes, documentation and test certificates (continued)</b>		
<b>F34</b>	Recording of current and torque curves with torque metering shaft during starting, without acceptance	0/21, 3/53 ...
<b>F35</b>	Recording of current and torque curves with torque metering shaft during starting, with acceptance	0/21, 3/53 ...
<b>F52</b>	Measurement of the locked-rotor torque and locked-rotor current, without acceptance	0/21, 3/53 ...
<b>F53</b>	Measurement of the locked-rotor torque and locked-rotor current, with acceptance	0/21, 3/53 ...
<b>F62</b>	Noise analysis, without acceptance	0/21, 3/53 ...
<b>F63</b>	Noise analysis, with acceptance	0/21, 3/53 ...
<b>F82</b>	Type test with heat run for horizontal motors, without acceptance	0/21, 3/53 ...
<b>F83</b>	Type test with heat run for horizontal motors, with acceptance	0/21, 3/53 ... 10/6, 10/10 ...
<b>F92</b>	Type test with heat run for vertical motors, without acceptance	0/21, 3/53 ...
<b>F93</b>	Type test with heat run for vertical motors, with acceptance	0/21, 3/53 ...
<b>L99</b>	Wire-lattice pallet	0/20
<b>M32</b>	Connected in star for dispatch	0/20
<b>M33</b>	Connected in delta for dispatch	0/20

# IEC Squirrel-Cage Motors

## Introduction motors 1LA, 1LG, 1LL, 1LP, 1MA, 1MJ, 1PP, 1PQ

General technical data

0

### Overview

*Cut-away diagram of a low-voltage motor*



- ① Motor protection Page 0/34  
Motor connection and connection box Page 0/38  
Voltage, currents and frequencies 0/22
- ② Windings and insulation Page 0/32  
Coolant temperature and site altitude Page 0/31
- ③ Heating and ventilation Page 0/36  
Mechanical design and degrees of protection Page 0/54  
Modular technology Page 0/75  
Special technology Page 0/85

- ④ Bearings and lubrication Page 0/58
- ⑤ Shaft and rotor Page 0/56  
Balance and vibration quantity Page 0/56
- ⑥ Colors and paint finish Page 0/17
- ⑦ Types of construction Page 0/52
- ⑧ Rating plates and extra rating plates Page 0/30

# IEC Squirrel-Cage Motors

## Introduction motors 1LA, 1LG, 1LL, 1LP, 1MA, 1MJ, 1PP, 1PQ

### General technical data

#### Designs in accordance with standards and specifications

##### Applicable standards and specifications

The motors comply with the appropriate standards and regulations, especially those listed in the table below.

Title	IEC/EN	DIN EN
General specifications for rotating electrical machines	IEC 60034-1, IEC 60085	DIN EN 60034-1
Specification of the losses and efficiency of rotating electrical machines	IEC 60034-2	DIN EN 60034-2
Asynchronous AC motors for general use with standardized dimensions and outputs	IEC 60072 fixing only	DIN EN 50347
Restart characteristics for rotating electrical machines	IEC 60034-12	DIN EN 60034-12
Terminal designations and direction of rotation for electrical machines	IEC 60034-8	DIN EN 60034-8
Designation for type of construction, installation and terminal box position	IEC 60034-7	DIN EN 60034-7
Entry to terminal box	–	DIN 42925
Built-in thermal protection	IEC 60034-11	DIN EN 60034-11
Noise limit values for rotating electrical machines	IEC 60034-9	DIN EN 60034-9
IEC standard voltages	IEC 60038	DIN IEC 60038
Cooling methods for rotating electrical machines	IEC 60034-6	DIN EN 60034-6
Vibration severity of rotating electrical machines	IEC 60034-14	DIN EN 60034-14
Vibration limits	–	DIN ISO 10816
Degrees of protection of rotating electrical machines	IEC 60034-5	DIN EN 60034-5
<b>In addition, the following applies to Ex motors:</b>		
General regulations	IEC/EN 60079-0	DIN EN 60079-0
Explosion-proof enclosure "d"	IEC/EN 60079-1	DIN EN 60079-1
Increased safety "e"	IEC/EN 60079-7	DIN EN 60079-7
Type of protection "n" (non sparking)	IEC/EN 60079-15	DIN EN 60079-15
Areas containing flammable dust	IEC/EN 61241	DIN EN 61241

##### National standards

The motors comply with the IEC or European standards listed above. The European standards replace the national standards in the following European countries:

Germany (VDE), France (NF C), Belgium (NBNC), Great Britain (BS), Italy (CEI), Netherlands (NEN), Sweden (SS), Switzerland (SEV) etc.

The motors also comply with various national standards. The following standards (with the exception of non-standard motors) have been harmonized with IEC publication 60034-1 or replaced with DIN EN 60034-1 so that the motors can be operated at standard rated output.

AS 1359	Australia (higher output assignment than stated in DIN EN 50347 for frame size 250 M and above)
CSA C22.2, No. 100	Canada
IS 325 IS 4722	India
NEK – IEC 60034-1	Norway

##### Explosion-proof motors:

Since the requirements of explosion-proof motors comply with the European standards EN 60079-0, EN 60079-1, EN 60079-7 and Directive 94/9/EG (ATEX 95), certificates issued by authorized testing agencies (PTB, DMT, etc.) are accepted by all member states of the EU. The remaining members of CENELEC, Switzerland in particular, also accept the certificates.

The EU is currently changing the standard series from EN 50014ff to IEC / EN 60079-xx and IEC / EN 61241-xx. The transition period is approximately 2 years. After changing the standards, the first E of the marking of the type of protection will be omitted. For example: Old: EEx de – New: Ex de. The first E represented Euronorm.

##### Tolerances for electrical data

According to DIN EN 60034, the following tolerances are permitted: Motors which comply with DIN EN 60034-1 must have a voltage tolerance of  $\pm 5\%$  / frequency tolerance of  $\pm 2\%$  (Design A), if utilized, the permitted limit temperature of the temperature class may be exceeded by 10 K.

A tolerance of  $\pm 5\%$  also applies to the rated voltage range in accordance with DIN EN 60034-1. Rated voltage and rated voltage range see Page 0/23.

Efficiency  $\eta$  for

$$P_{\text{rated}} \leq 150 \text{ kW: } -0.15 \cdot (1 - \eta)$$

$$P_{\text{rated}} > 150 \text{ kW: } -0.1 \cdot (1 - \eta)$$

with  $\eta$  being a decimal number.

$$\text{Power factor} - \frac{1 - \cos \varphi}{6}$$

- Minimum absolute value: 0.02
- Maximum absolute value: 0.07

Slip  $\pm 20\%$  (for motors  $< 1 \text{ kW}$   $\pm 30\%$  is admissible)

Locked-rotor current  $+20\%$

Locked-rotor torque  $-15\%$  to  $+25\%$

Breakdown torque  $-10\%$

Moment of inertia  $\pm 10\%$

 1MA motors:

Add 10 % to the certified values for the locked-rotor current.



Energy-saving motors with European efficiency classification in accordance with EU/CEMEP (European Committee of Manufacturers of Electrical Machines and Power Electronics)

Low-voltage motors in the output range of 1.1 to 90 kW, 2-pole and 4-pole are marked in accordance with the EU/CEMEP agreement with the efficiency class  $\text{EFF2}$  (Improved Efficiency) or  $\text{EFF}$  (High Efficiency).

So that the requirements of efficiency classes  $\text{EFF}$  and  $\text{EFF2}$  are fulfilled, the active parts of the motor have been optimized. The procedure for calculating the efficiency is based on the loss-summation method according to IEC 60034-2.

#### Motors for the North American market

For motors which comply with North American regulations (NEMA, CSA, UL, etc.), it must always be checked whether the motors will be used in the US or Canada and whether they are subject to state laws.

#### Minimum efficiencies required by law

In 1997, an act was passed in the US to define minimum efficiencies for low-voltage three-phase motors (EPACT = Energy Policy Act). An act is in force in Canada that is largely identical, although it is based on different verification methods. The efficiency is verified for these motors for the USA using IEEE 112, Test Method B and for Canada using CSA-C390. Apart from a few exceptions, all low-voltage three-phase motors exported to the USA or Canada must comply with the legal requirements on efficiency.

The law requires minimum efficiencies for 2, 4 and 6-pole motors with a voltage of 230 and 460 V/60 Hz, in the output range of 1 to 200 HP (0.75 to 150 kW). Explosion-proof motors must also be included. 1LA9 and 1LG6 are also available in the design for Zones 2, 21 and 22.

According to EPACT, the following are excluded from the efficiency requirements, for example.

- Motors whose frame size output classification does not correspond with the standard series according to NEMA MG1-12.
- Flange-mounting motors without feet
- Brake motors
- Converter-fed motors
- Motors with design letter C and higher

For more information on EPACT:

<http://www.eren.doe.gov/>

#### Special requirements for the USA: Energy Policy Act

The act lays down that the nominal efficiency at full load and a "CC" number (Compliance Certification) must be included on the rating plate. The "CC" number is issued by the US Department of Energy (DOE). The following information is stamped on the rating plate of EPACT motors which must be marked by law: Nominal efficiency (service factor SF 1.15), design letter, code letter, CONT, CC-Nr. CC 032A (Siemens) and NEMA MG1-12.

#### Special requirements for Canada: CSA – Energy Efficiency Verification

These motors fulfill the minimum efficiency requirements laid down by the CSA standard C390. These motors are available as 1LA9 or 1LG6 and can be ordered with order code **D40** and are also marked with the CSA-E verification on the rating plate.



#### NEMA – Order code D30

The motors with increased efficiency according to EPACT are designed to meet the NEMA MG1-12 electrical standard and are marked accordingly. The mechanical design of all motors is compliant only to IEC, not to NEMA dimensions.

All motors in the **D30** version correspond to NEMA Design A (i. e. standard torque characteristic in accordance with NEMA and no starting current limitation).

For Design B, C and D, a special version is required (on request). According to NEC-ANSI-C1, Division 2, Class I, Group A, B, D, all 1LA/1LG motors that comply with Zone 2 can be used.

All other 1LA/1LG motors must be ordered with order code **D30**. Data on the rating plate: Rated voltage (voltage tolerance of  $\pm 10\%$ ), nominal efficiency, design letter, code letter, CONT and NEMA MG1-12.

#### UL approval – Order code D31

The motors based on the 1LA/1LG basic series are listed for up to 600 V by Underwriters Laboratories Inc. ("Recognition Mark" = R/C).

For Zones 2, 21, 22 and Ex e motors or Ex de motors as well as marine motors, there is no listing.

This is not possible in combination with the option "temperature class 180 (H) at rated output and maximal coolant temperature of 60 °C", order code **C18**.

The motors must be ordered with order code **D31**, voltage code "9" and the order code for voltage and frequency.

According to UL, motor voltages are only certified up to 600 V, i. e. voltage codes 1, 3, 4 or 5. For this reason, voltage code "6" for example is omitted (400 V $\Delta$ /690 VY/ 50 Hz or 460 V $\Delta$ /60 Hz). Voltages 400 V $\Delta$  and 460 V $\Delta$ , for example, should be ordered as follows:

Voltage	Voltage code
400 V $\Delta$ /50 Hz or 460 V $\Delta$ /60 Hz (50 Hz output)	9 with <b>L1U</b> <sup>1)</sup>
460 V $\Delta$ /60 Hz (50 Hz output)	9 with <b>L2T</b>
460 V $\Delta$ /60 Hz (60 Hz output)	9 with <b>L2F</b>

The "UL Recognition Mark" is included on the rating plate of the motor.



In addition, the motor is designed to meet the NEMA MG1-12 electrical standard (with the exception of non-standard motors) and includes the following data on the rating plate: Rated voltage (voltage tolerance of  $\pm 10\%$ ), nominal efficiency, design letter, code letter, CONT and NEMA MG1-12.

Externally or internally mounted components such as

- Motor protection
- Heating element
- Separately driven fan
- Brake
- Encoder
- Power connection
- Plug connector

are UL-R/C, CSA or C-US listed or used by manufacturers in accordance with regulations. It may have to be decided whether the motor is suitable for the application.

The motors can be operated with a frequency converter – separate converter or built-on (**1UA7**/order code **H15**) – with 50/60 Hz.

Deviating frequency settings must be tested at final acceptance.

The external fans for 1LA8 and 1LL8 motors must be made of metal.

The following versions are possible:

- 2-pole<sup>2)</sup> motors, only in combination with K37 or K38
- 4, 6 and 8-pole motors, only in combination with K35

<sup>1)</sup> Only applicable to non-standard motors.

<sup>2)</sup> Frame size 450 in 2-pole version, on request.

# IEC Squirrel-Cage Motors

## Introduction motors 1LA, 1LG, 1LL, 1LP, 1MA, 1MJ, 1PP, 1PQ

### General technical data

0

For 1PQ8 motors, UL listed motors with separately driven fan (400 V  $\Delta$  50 Hz/460 V  $\Delta$  60 Hz) are used. Other voltages up to 600 V and/or other frequencies must be ordered using the order code Y81 and plain text. For 1LA8 and 1PQ8 motors of frame size 315, when option **D31** is ordered, connection box gt 640 will be automatically replaced without additional charge with connection box 1XB1 621. The connection boxes are designed with an undrilled cable entry. UL-R/C cable glands must be used for cable entry.

#### CSA approval – Order code D40

Motors based on the 1LA/1LG basic series are approved for up to 690 V in accordance with the Canadian regulations of the “Canadian Standard Association” (CSA). Externally or internally mounted components which are used are listed by CSA or are used by manufacturers in accordance with regulations. It may have to be decided whether the motor is suitable for the application. For Zones 2, 21, 22 and Ex e motors or Ex de motors as well as marine motors, there is no approval.

This is not possible in combination with the option “temperature class 180 (H) at rated output and maximal coolant temperature of 60 °C”, order code C18, for 1LA5, 1LG4, 1PP4 and 1PP5 motor series.

The motors must be ordered with the order code **D40**, voltage code “**9**” and order code for voltage and frequency. The CSA mark and the rated voltage (voltage tolerance of  $\pm 10\%$ ) are included on the rating plate.



When energy-saving motors (1LA9, 1LG6) are ordered, they also include the CSA-E mark on the rating plate.



Other versions:

For versions and certification of explosion-proof motors in compliance with directive 94/9/EU (ATEX) as well as VIK versions, see catalog part 4 “Explosion-proof motors”.

For versions for use in shipping, see Section 10 “Marine motors”.

#### Export of low-voltage motors to China

##### CCC – China Compulsory Certification – Order code D01

“Small power motors” which are exported to China must be certified up to a rated output of:

2-pole:  $\leq 2.2$  kW

4-pole:  $\leq 1.1$  kW

6-pole:  $\leq 0.75$  kW

8-pole:  $\leq 0.55$  kW

The **1LA7, 1LA9, 1MA7 and 1MJ6** motors which must be certified have been certified by the CQC (China Quality Cert. Center). When ordered with the D01 order code, the “CCC” logo and “Factory Code” are included on the rating plate and packaging.



A005216

Factory Code:

**A005216** = Works Bad Neustadt

**A010607** = Works Mohelnice

Note:

Chinese customs checks the need for certification of imported products by means of commodity code.

The following do not need to be certified:

- Motors imported to China which have already been installed in a machine
- Repair parts

#### Export of low-voltage motors to Japan

##### PSE Mark Japan – Order Code D46

PSE marking is a mandatory certification in Japan in accordance with the electrical devices and safety of materials act. “Small power motors” with a rated output of up to 3 kW which are exported to Japan must bear the PSE marking. Marking is only applicable to motor series 1LA7, 1LP7, 1PP7 in catalog parts 2 “Standard motors up to frame size 315 L” and 7 “Motors with fans”.

The motors concerned are marked on the rating plate with the following “PSE” logo.



#### Export of low-voltage motors to Korea

##### Korea certification – Order Code D33

Certification confirms that the efficiency and power factor are in compliance with KSC 4202 (KEMCO). The certification is applicable to EFF1 motors of the 1LA9 and 1LG6 series in 2, 4 and 6 pole versions from 0.75 kW to 200 kW 400 V 50 Hz.

# IEC Squirrel-Cage Motors

## Introduction motors 1LA, 1LG, 1LL, 1LP, 1MA, 1MJ, 1PP, 1PQ

### General technical data

#### Colors and paint finish

To protect the drives against corrosion and external influences, high-quality coatings based on 2-K epoxy resin are offered in various different colors.

Version	Suitability of paint finish for climate group in accordance with DIN IEC 60721, Part 2-1	
Standard finish	Moderate (extended) for indoors and outdoors under a roof not directly subjected to weather conditions	Briefly: up to 120 °C Contin.: up to 100 °C
Special finish	Worldwide (global) for outdoor use in direct sunlight and/or weather conditions. Suitable for use in the tropics for <60 % relative humidity at 40 °C	Briefly: up to 140 °C Contin.: up to 120 °C Also: for aggressive atmospheres up to 1 % acid and alkali concentration or permanent dampness in sheltered rooms

“Sea air resistant” special finish system – Order code **M94**

Field of application	Resistance
<ul style="list-style-type: none"> <li>Recommended for indoor installations or outdoor installations exposed to direct weather conditions</li> <li>Industrial climate with moderate SO<sub>2</sub> exposure, inshore maritime climate, but not offshore maritime climate, e.g. for crane drives and also in the paper industry</li> <li>Complies with the test requirements of DIN EN ISO 12944-2 Corrosion Category C4</li> </ul>	<ul style="list-style-type: none"> <li>Chemical exposure to 5 % acid and caustic solution concentration</li> <li>Suitable for use in the tropics up to 75 % relative humidity at 50 °C</li> <li>Thermal stability from –40 to 140 °C</li> </ul>

“Offshore” special finish system – Order code **M91**

Field of application	Resistance
<ul style="list-style-type: none"> <li>Recommended for outdoor installations exposed to direct weather conditions</li> <li>Industrial climate with moderate SO<sub>2</sub> exposure and offshore maritime climate, e.g. for crane drives</li> <li>Complies with the test requirements of DIN EN ISO 12944-2 Corrosion Category C5</li> </ul>	<ul style="list-style-type: none"> <li>Chemical exposure to 5 % acid and caustic solution concentration</li> <li>Suitable for use in the tropics up to 75 % relative humidity at 60 °C</li> <li>Thermal stability from –40 to 140 °C</li> </ul>

All motors are painted with RAL 7030 (stone gray) if the color is not specified.

Other colors can be ordered with standard finish using order code **Y53** and the RAL number in plain text for an additional charge (for an overview of the available RAL No./RAL colors see the following table for order code **Y53**).

Other colors in special finish must be ordered with the order code **Y51** or **Y54** and the RAL number in plain text (for an overview of the available RAL No./RAL colors, see the following tables for order codes **Y51** and **Y54**).

Direct sunlight can change the color. If color stability is required, it is recommended to use a polyurethane-based paint (only on request).

All paint finishes can be painted over with commercially available paints. Special paint with increased layer thickness available on request.

If required, the motors can be supplied only coated in primer, order code **K24**, or unpainted (unworked cast-iron surfaces in primer) using order code **K23**.

# IEC Squirrel-Cage Motors

## Introduction motors 1LA, 1LG, 1LL, 1LP, 1MA, 1MJ, 1PP, 1PQ

### General technical data

0

Standard finish in other standard RAL colors – Order code **Y53**  
(RAL number is required in plain text)

RAL No.	Color name	RAL No.	Color name
1002	Sand yellow	6011	Reseda green
1013	Pearl white	6019	Pastel green
1015	Light ivory	6021	Pale green
1019	Gray beige	7000	Squirrel gray
2003	Pastel orange	7001	Silver gray
2004	Pure orange	7004	Signal gray
3000	Flame red	7011	Iron gray
3007	Black red	7016	Anthracite gray
5007	Brilliant blue	7022	Umber gray
5009	Azure blue	7031	Blue gray
5010	Gentian blue	7032	Pebble gray
5012	Light blue	7033	Cement gray
5015	Sky blue	7035	Light gray
5017	Traffic blue	9001	Cream
5018	Teal blue	9002	Gray white
5019	Capri blue	9005	Jet black

Special finish in standard RAL color with defined order codes  
(special finish in other standard RAL colors can be ordered  
indicating the RAL number in plain text with order code **Y54** )

For 1LA5, 1LA6, 1LA7, 1LA9, 1MA7, 1MA6, 1MJ6, 1PP5, 1LP5,  
1PP7 and 1LP7 motors up to frame size 200 L, the special finish  
is in RAL 7030 stone gray (order code **K26**) standard version.

RAL No.	Color name	Order code
7030	Stone gray	<b>K26</b>

Special finish in other standard RAL colors – Order code **Y54**  
(RAL number is required in plain text)

RAL No.	Color name	RAL No.	Color name
1002	Sand yellow	6011	Reseda green
1013	Pearl white	6019	Pastel green
1015	Light ivory	6021	Pale green
1019	Gray beige	7000	Squirrel gray
2003	Pastel orange	7001	Silver gray
2004	Pure orange	7004	Signal gray
3000	Flame red	7011	Iron gray
3007	Black red	7016	Anthracite gray
5007	Brilliant blue	7022	Umber gray
5009	Azure blue	7031	Blue gray
5010	Gentian blue	7032	Pebble gray
5012	Light blue	7033	Cement gray
5015	Sky blue	7035	Light gray
5017	Traffic blue	9001	Cream
5018	Teal blue	9002	Gray white
5019	Capri blue	9005	Set black

# IEC Squirrel-Cage Motors

## Introduction motors 1LA, 1LG, 1LL, 1LP, 1MA, 1MJ, 1PP, 1PQ

### General technical data

Special finish in special RAL colors – Order code **Y51** (RAL number is required in plain text)

RAL No.	Color name	RAL No.	Color name	RAL No.	Color name	RAL No.	Color name
1000	Green beige	3014	Antique pink	6003	Olive green	7036	Platinum gray
1001	Beige	3015	Light pink	6004	Blue green	7037	Dusty gray
1003	Signal yellow	3016	Coral red	6005	Moss green	7038	Agate gray
1004	Golden yellow	3017	Rose	6006	Gray olive	7039	Quartz gray
1005	Honey yellow	3018	Strawberry red	6007	Bottle green	7040	Window gray
1006	Maize yellow	3020	Traffic red	6008	Brown green	7042	Traffic gray A
1007	Daffodil yellow	3022	Salmon pink	6009	Fir green	7043	Traffic gray B
1011	Brown beige	3027	Raspberry red	6010	Grass green	7044	Silk gray
1012	Lemon yellow	3031	Orient red	6012	Black green	7045	Tele gray 1
1014	Dark ivory	3032	Pearl ruby red	6013	Reed green	7046	Tele gray 2
1016	Sulfur yellow	3033	Pearl pink	6014	Yellow olive	7047	Tele gray 4
1017	Saffron yellow	4001	Red lilac	6015	Black olive	7048	Pearl mouse gray
1018	Zinc yellow	4002	Red violet	6016	Turquoise green	8000	Green brown
1020	Olive yellow	4003	Heather violet	6017	May green	8001	Ocher brown
1021	Rape yellow	4004	Claret violet	6018	Yellow green	8002	Signal brown
1023	Traffic yellow	4005	Blue lilac	6020	Chrome green	8003	Clay brown
1024	Ochre yellow	4006	Traffic purple	6022	Olive drab	8004	Copper brown
1027	Curry	4007	Purple violet	6024	Traffic green	8007	Fawn brown
1028	Melon yellow	4008	Signal violet	6025	Fern green	8008	Olive brown
1032	Broom yellow	4009	Pastel violet	6026	Opal green	8011	Nut brown
1033	Dahlia yellow	4010	Tele magenta	6027	Light green	8012	Red brown
1034	Pastel yellow	4011	Pearl violet	6028	Pine green	8014	Sepia brown
1035	Pearl beige	4012	Pearl blackberry	6029	Mint green	8015	Chestnut
1036	Pearl gold	5000	Violet blue	6032	Signal green	8016	Mahogany
1037	Sun yellow	5001	Green blue	6033	Mint turquoise	8017	Chocolate
2000	Yellow orange	5002	Ultramarine	6034	Pastel turquoise	8019	Gray brown
2001	Red orange	5003	Sapphire blue	6035	Pearl green	8022	Black brown
2002	Vermilion	5004	Black blue	6036	Pearl opal green	8023	Orange brown
2008	Bright red orange	5005	Signal blue	7002	Olive gray	8024	Beige brown
2009	Traffic orange	5008	Gray blue	7003	Moss gray	8025	Pale brown
2010	Signal orange	5011	Steel blue	7005	Mouse gray	8028	Terra brown
2011	Deep orange	5013	Cobalt blue	7006	Beige gray	8029	Pearl copper
2012	Salmon orange	5014	Pigeon blue	7008	Khaki gray	9003	Signal white
2013	Pearl orange	5020	Ocean blue	7009	Green gray	9004	Signal black
3001	Signal red	5021	Water blue	7010	Tarpaulin gray	9006	White aluminum
3002	Carmine red	5022	Night blue	7012	Basalt gray	9007	Gray aluminum
3003	Ruby red	5023	Distant blue	7013	Brown gray	9010	Pure white
3004	Purple red	5024	Pastel blue	7015	Slate gray	9011	Graphite black
3005	Wine red	5025	Pearl gentian	7021	Black gray	9016	Traffic white
3009	Oxide red	5026	Pearl night blue	7023	Concrete gray	9017	Traffic black
3011	Brown red	6000	Patina green	7024	Graphite gray	9018	Papyrus white
3012	Beige red	6001	Emerald green	7026	Granite gray	9022	Pearl light gray
3013	Tomato red	6002	Leaf green	7034	Yellow gray	9023	Pearl dark gray

Coating structure and colors not specified in the catalog are available on request.

# IEC Squirrel-Cage Motors

## Introduction motors 1LA, 1LG, 1LL, 1LP, 1MA, 1MJ, 1PP, 1PQ

### General technical data

#### Packaging, safety notes, documentation and test certificates

##### Connected in star for dispatch – Order code **M32**

The terminal board of the motor is connected in star for dispatch.

##### Connected in delta for dispatch – Order code **M33**

The terminal board of the motor is connected in delta for dispatch.

#### Packing weights and packing dimensions

Packing weights		For land transport					
For motors Frame size	Type 1LA5 .../1LA7 ..., 1LA6 ..., 1LA9 ..., 1LG4 ..., 1LG6 ..., 1LP4 ..., 1LP5 .../1LP7 ..., 1MA6 ..., 1MA7 ..., 1MJ6 ..., 1MJ7 ..., 1PP4 ..., 1PP5 .../1PP7 ...	Type of construction IM B3			Types of construction IM B5, IM V1		
		In box Tare	On battens Tare	In crate Tare	In box Tare	On battens Tare	In crate Tare
		kg	kg	kg	kg	kg	kg
56 M	... 050/053	0.65	–	–	0.65	–	–
63 M	... 060/063	0.65	–	–	0.65	–	–
71 M	... 070	0.65	–	–	0.65	–	–
	... 073	0.65	–	–	0.65	–	–
80 M	... 080	0.65	–	–	0.65	–	–
	... 083	0.65	–	–	0.65	–	–
90 S	... 090	0.65	–	–	0.65	–	–
90 L	... 096/097	0.65	–	–	0.65	–	–
100 L	... 106/107	1.3	–	–	1.3	–	–
112 M	... 113	1.5	–	–	1.5	–	–
132 S	... 130/131	4.7	–	–	5.2	–	–
132 M	... 133/134	4.7	–	–	5.2	–	–
160 M	... 163/164	4.8	–	–	5.7	–	–
160 L	... 166	4.8	–	–	5.7	–	–
180 M	... 183	13.0	–	–	13.4	–	–
180 L	... 186	13.0	–	–	13.4	–	–
200 L	... 206/207	13.5	–	–	13.5	–	–
225 S	... 220	13.7	7	20	13.7	10	20
225 M	... 223	13.7	7	20	13.7	10	20
250 M	... 253	–	20	36	–	20	40
280 S	... 280	–	20	36	–	20	40
280 M	... 283	–	20	36	–	20	40
315 S	... 310	–	20	38	–	20	45
315 M	... 313	–	20	38	–	20	45
315 L	... 316/317/318	–	22	40	–	22	45

Values for 1PP6 motors on request.

Data apply for individual packaging. For frame sizes 56 to 180 L, wire-lattice pallets can be used, order code **L99**.

#### Packing weights and packing dimensions for 1LA8, 1PQ8 and 1LL8 motors

For motors Frame size	Type 1LA8 ..., 1PQ8 ..., 1LL8 ...	Packing weights			
		Land transport on battens		Sea transport in wooden cases	
		Type of construction IM B3 Tare	Type of construction IM V1 Tare	Type of construction IM B3 Tare	Type of construction IM V1 Tare
		kg	kg	kg	kg
315	... 315/317	30	55	270	310
355	... 353/355/357	40	65	320	365
400	... 403/405/407	45	75	390	445
450	... 453/455/457	50	85	450	510
Maximum motor dimensions		Allowances for maximum motor dimensions (packing dimensions = motor dimensions + allowance)			
		Land transport on battens		Sea transport in wooden cases	
		Type of construction IM B3	Type of construction IM V1	Type of construction IM B3	Type of construction IM V1
		approx.	approx.	approx.	approx.
		mm	mm	mm	mm
Length		+250	+250	+250	+250
Width		+200	+300	+200	+200
Height		+200	+250	+500	+500

Safety notes

The motors are supplied without safety and commissioning notes for most motor types and frame sizes. A customer's declaration of renouncement is required.

**Without safety and commissioning note** – Order code **B00**

The motors are supplied with only one set of safety and commissioning notes per wire-lattice pallet for most motor types and frame sizes.

**Complete with one set of safety and commissioning notes per wire-lattice pallet** – Order code **B01**Documentation

The documentation for non-standard motors frame size 315 and above (catalog part 3) contains as standard:

- Safety and commissioning notes (paper)
- Operating instructions (on CD)
- EU manufacturer's declaration (on CD)
- Acceptance test certificate 3.1 according to EN 10204 (by e-mail)
- Routine test certificate (by e-mail)

For non-standard motors from frame size 315 and above (catalog part 3) the following documents are optionally available:

- Document – Electrical data sheet – Order code **B31**
- Document – Order dimension drawing – Order code **B32**
- Document – Load characteristics – Order code **B37** (on request, only available for motors for mains-fed operation)

Optionally available documents for other motors:

- Operating instructions German/English enclosed in print – Order code **B23**
- "SD Manual Collection": all manuals for low-voltage motors, geared motors and low-voltage converters on DVD in 5 languages, see catalog part 11 "Appendix".

Test certificates**Acceptance test certificate 3.1 according to EN 10204** – Order code **B02**

An acceptance test certificate 3.1 according to EN 10204 can be supplied for most motors.

*The tests listed below are mainly intended for non-standard motors (catalog part 3). The assignment of order codes to motor types can be found in the "Special versions" section of the relevant catalog parts.*

**Standard test (routine test) with acceptance** – Order code **F01**

Standard routine testing of the motor, but with acceptance by an external representative (e.g. customer). The routine test is required to check the correct functioning of a motor where the characteristic data are known and were determined on a machine of the same type in a detailed type test. For a routine test, characteristic variables are determined, which after being converted to the basic data, are compared with the reference values for this machine type.

**Visual acceptance and report handover with acceptance** – Order code **F03**

Visual acceptance of the motor by external representative (e.g. customer) and handover of the routine test report to external representative (e.g. customer).

**Temperature-rise test without acceptance** – Order code **F04**

For the temperature-rise test, the temperature rise of a motor is measured in continuous duty. To do this, the motor is connected to a load (dynamometer), and operated with the rated power.

**Temperature-rise test with acceptance** – Order code **F05**

As for order code F04, but with acceptance by an external representative (e.g. customer).

**Noise measurement during idling, no noise analysis, no acceptance** – Order code **F28**

The A-rated sound pressure level  $L_{pA}$  is measured during idling at rated voltage. The number of measuring points and their locations are specified in the test certificate.

**Noise measurement during idling, no noise analysis, with acceptance** – Order code **F29**

As for order code F28, but with acceptance by an external representative (e.g. customer).

**Recording of current and torque curves with torque metering shaft during starting, without acceptance** – Order code **F34**

The measurement is used to determine the starting response of a motor. By comparison with the load torque characteristic, the acceleration torque can be calculated. This can be used to check that a complete machine set has started correctly. This measurement is only meaningful for motors that are directly mains-fed and is not offered for motors that are designed for converter-fed operation.

**Recording of current and torque curves with torque metering shaft during starting, with acceptance** – Order code **F35**

As for order code F34, but with acceptance by an external representative (e.g. customer).

**Measurement of the locked-rotor torque and locked-rotor current without acceptance** – Order code **F52**

The torque and current are determined when the rotor is locked. This measurement is only meaningful for motors that are directly mains-fed and is not offered for motors that are designed for converter-fed operation.

**Measurement of the locked-rotor torque and locked-rotor current with acceptance** – Order code **F53**

As for order code F52, but with acceptance by an external representative (e.g. customer).

**Noise measurement during idling, with noise analysis, without acceptance** – Order code **F62**

As for F28, but a noise analysis is also performed. The signal is divided up into frequency bands and the level is determined in each band.

**Noise measurement during idling, with noise analysis, with acceptance** – Order code **F63**

As for order code F62, but with acceptance by an external representative (e.g. customer).

**Type test with heat run for horizontal motors, without acceptance** – Order code **F82**

During the type test, a temperature-rise test is performed; no-load, short-circuit and load characteristics are recorded; the iron losses and friction losses are determined and the efficiency is calculated from the summed losses. This option is only applicable to motors with a horizontal type of construction.

**Type test with heat run for horizontal motors, with acceptance** – Order code **F83**

As for order code F82, but with acceptance by an external representative (e.g. customer, classification society).

**Type test with heat run for vertical motors, without acceptance** – Order code **F92**

As for order code F82, but only for motors with a vertical type of construction.

**Type test with heat run for vertical motors, with acceptance** – Order code **F93**

As for order code F92, but with acceptance by an external representative (e.g. customer, classification society).

# IEC Squirrel-Cage Motors

## Introduction motors 1LA, 1LG, 1LL, 1LP, 1MA, 1MJ, 1PP, 1PQ

### General technical data

0

#### Voltages, currents and frequencies

##### Standard voltages

EN 60034-1 differentiates between Category A (combination of voltage deviation  $\pm 5\%$  and frequency deviation  $\pm 2\%$ ) and Category B (combination of voltage deviation  $\pm 10\%$  and frequency deviation  $+3/-5\%$ ) for voltage and frequency fluctuations. The motors can supply their rated torque in both Category A and Category B. In Category A, the temperature rise is approx. 10 K higher than during normal operation.

Standard	Category	Category
EN 60034 – 1	A	B
Voltage deviation	$\pm 5\%$	$\pm 10\%$
Frequency deviation	$\pm 2\%$	$+3\%/-5\%$
Rating plate data stamped with rated voltage (e.g. 230 V)	a $\pm 5\%$ (e.g. 230 V $\pm 5\%$ )	a $\pm 10\%$ (e.g. 230 $\pm 10\%$ )
Rating plate data stamped with rated voltage ranges b to c (e.g. 220 to 240 V)	b $-5\%$ to c $+5\%$ (e.g. 220 $-5\%$ to 240 $+5\%$ )	b $-10\%$ to c $+10\%$ (e.g. 220 $-10\%$ to 240 $+10\%$ )

According to the standard, longer operation is not recommended for Category B, therefore this is not permitted for explosion-proof motors. See Page 0/31 for details of the rating plate inscriptions and examples. The selection and ordering data state the rated current at 400 V and where applicable 690 V. The DIN IEC 60038 standard specifies a tolerance of  $\pm 10\%$  for mains voltages of 230 V, 400 V and 690 V. The rating plates of motors with voltage code 0, 1 or 6 also include a rated voltage range in addition to the rated voltage (see table).

The rated currents at 420 V and for 1LA8 motors 660 V or 725 V are listed in the table on Pages 0/26, 0/27 and on the rating plate.

The tolerance laid down by DIN EN 60034-1 applies to all converter-fed 1LA8 motors as well as to 1LA5, 1LA7, 1LG6, 1PQ8 and 1LL8 motors with special 690 V insulation, i.e. no rated voltage range is specified on the rating plate.

For 1LA and 1LG motors, type of protection "n" (Zone 2), a rated voltage range is not specified.

Mains voltages	Rated voltage range	Voltage code
<b>1LA, 1LG, 1MJ, 1PQ8 and 1LL8 motors</b>		
230 V $\Delta$ /400 VY, 50 Hz	220 ... 240 V $\Delta$ /380 ... 420 VY 50 Hz	1 <sup>1)</sup>
400 V $\Delta$ /690 VY, 50 Hz	380 ... 420 V $\Delta$ /660 ... 725 VY, 50 Hz	6
500 VY, 50 Hz	–	3
500 V $\Delta$ , 50 Hz	–	5
<b>1LA and 1LG motors</b>		
Second rating plate with 50 and 60 Hz data, frame sizes 56 to 315 M for 1LA9 and 1LG6 with output at 60 Hz additionally in HP		
460 V, 60 Hz	440 ... 480V, 60 Hz	1, 6
<b>1MA motors</b>		
230 V $\Delta$ /400 VY, 50 Hz	218 ... 242 V $\Delta$ /380 ... 420 VY, 50 Hz	1
400 V $\Delta$ /690 VY, 50 Hz	380 ... 420 V $\Delta$ /655 ... 725 VY, 50 Hz	6

#### 1MA motors:

For non-standard frequencies, the  $t_E$  times and, where applicable, the rated output, may differ from those specified in the selection tables; in this case, a new or supplementary certificate is needed. For  $\Delta$  connection, overload protection with phase-failure protection must be provided.

#### Non-standard voltages and/or frequencies

The tolerance laid down by DIN EN 60034-1 applies to all non-standard voltages.

Order codes have been allocated for a number of non-standard voltages at 50 or 60 Hz. They are ordered by specifying the code digit 9 for voltage in the 11th position of the Order No. and the appropriate order code.

#### L8Y Standard winding

Winding in accordance with voltage codes 0, 4, 5, 6, 7 or 8; rating plate is stamped with order details.

The rated voltage is permitted to deviate up to  $\pm 5\%$  from the medium voltage of the defined voltage codes (0, 4, 5, 6, 7 or 8). The order code **L8Y** is only possible for non-standard motors of the motor series 1LA8, 1PQ8 and 1LL8. Order code **L8Y** does not apply to explosion-proof motors, converter-fed motors and motors for the North American market (in connection with order codes D30, D31 or D40).

**L1Y** Non-standard winding for voltages between 200 V (380 V for 1LA8, 1PQ8 and 1LL8 motor series) and 690 V and rated outputs.

For voltages and rated outputs outside these ranges, please inquire.

Motor series	Frame size	Rated voltages for L1Y that can be supplied Lowest / highest voltage in V for	
		Delta	Star
<b>1LA7, 1LA9, 1LP7, 1MA7, 1MJ6, 1PP7</b>	56 ... 90	200/500 <sup>2)</sup>	250/690 <sup>3)</sup>
<b>1LA6, 1LA7, 1LA9, 1LP7, 1MA6, 1MA7, 1MJ6, 1PP6, 1PP7</b>	100 ... 160	200/690	250/690
<b>1LA5, 1LA9, 1LP5, 1MA6, 1MJ6, 1PP5, 1PP6</b>	180 ... 200	200/690	250/690
<b>1LA5, 1LP5, 1PP5</b>	225	200/690	250/690

**L3Y** Non-standard winding Y/ $\Delta$  starting at low speed (only possible for 1LA7 and 1LA5 pole-changing motors).

When ordering **L8Y**, **L1Y** and **L3Y**, state in plain text: Voltage, frequency and connection.

#### Order codes for other rated voltages in the relevant catalog parts

For converter-fed motors and smoke extraction motors, only order code **L1Y** is possible. For non-standard motors, order code **L8Y** is also possible for converter-fed operation. The order codes listed below are possible for other motors; see the relevant catalog parts.

<sup>1)</sup> Not applicable to non-standard motors.

<sup>2)</sup> Highest voltage in delta circuit for 1MA7 060-2 and 1MA7 063-4 290 V as well as for 1MA7 060-4 230 V.

<sup>3)</sup> Highest voltage in star circuit for 1MA7 060-2 and 1MA7 063-4 500 V as well as for 1MA7 060-4 400 V.



# IEC Squirrel-Cage Motors

## Introduction motors 1LA, 1LG, 1LL, 1LP, 1MA, 1MJ, 1PP, 1PQ

### General technical data

0

#### Further voltages for standard motors

Voltage at <b>50 Hz</b>	Required output at <b>50 Hz</b>	Order code for <b>50 Hz constant-speed motors</b> (not pole-changing) <sup>1)</sup>	Frame sizes for motor					
			1LA5, 1LA7	1LA6	1LA9	1LG4, 1LG6	1LP5, 1LP7	1LP4
220 VΔ/380 VY <sup>2)</sup> (210 ... 230 VΔ/ 360 ... 400 VY)	50 Hz output	<b>L1R</b>	56 ... 225	100 ... 160	56 ... 200	180 ... 315 M	63 ... 200	180 ... 315 L
230 VΔ (220 ... 240 VΔ)	50 Hz output	<b>L1E</b>	56 ... 225	100 ... 160	56 ... 200	180 ... 315 M	63 ... 200	180 ... 315 M
380 VΔ/660 VY <sup>3)</sup> (360 ... 400 VΔ/ 625 ... 695 VY)	50 Hz output	<b>L1L</b>	56 ... 225	100 ... 160	56 ... 200	180 ... 315 L	63 ... 200	180 ... 315 L
415 VY (395 ... 435 VY)	50 Hz output	<b>L1C</b>	56 ... 225	100 ... 160	56 ... 200	180 ... 315 M	63 ... 200	180 ... 315 L
415 VΔ (395 ... 435 VΔ)	50 Hz output	<b>L1D</b>	56 ... 225	100 ... 160	56 ... 200	180 ... 315 L	63 ... 200	180 ... 315 L
400 VY (380 ... 420 VY)	50 Hz output	<b>L1A</b>	56 ... 225	100 ... 160	56 ... 200	180 ... 315 M	63 ... 200	180 ... 315 L
400 VΔ (380 ... 420 VΔ)	50 Hz output	<b>L1B</b>	56 ... 225	100 ... 160	56 ... 200	180 ... 315 L	63 ... 200	180 ... 315 L
400 VΔ (460 VΔ at 60 Hz) (380 ... 420 VΔ)	50 Hz output	<b>L1U</b>	56 ... 225	100 ... 160	56 ... 200	180 ... 315 L	63 ... 200	180 ... 315 L

Voltage at <b>60 Hz</b>	Required output at <b>60 Hz</b>	Order code for <b>60 Hz constant-speed motors</b> (not pole-changing)	Frame sizes for motors					
			1LA5, 1LA7	1LA6	1LA9	1LG4, 1LG6	1LP5, 1LP7	1LP4
220 VΔ/380 VY	50 Hz output	<b>L2A</b>	56 ... 225	100 ... 160	56 ... 200	180 ... 315 M	63 ... 200	180 ... 315 L
220 VΔ/380 VY	60 Hz output	<b>L2B</b>	56 ... 225	100 ... 160	56 ... 200	180 ... 315 M	63 ... 200	180 ... 315 L
380 VΔ/660 VY	50 Hz output	<b>L2C</b>	56 ... 225	100 ... 160	56 ... 200	180 ... 315 L	63 ... 200	180 ... 315 L
380 VΔ/660 VY	60 Hz output	<b>L2D</b>	56 ... 225	100 ... 160	56 ... 200	180 ... 315 L	63 ... 200	180 ... 315 L
440 VY	50 Hz output	<b>L2Q</b>	56 ... 225	100 ... 160	56 ... 200	180 ... 315 M	63 ... 200	180 ... 315 L
440 VY	60 Hz output	<b>L2W</b>	56 ... 225	100 ... 160	56 ... 200	180 ... 315 M	63 ... 200	180 ... 315 L
440 VΔ	50 Hz output	<b>L2R</b>	56 ... 225	100 ... 160	56 ... 200	180 ... 315 L	63 ... 200	180 ... 315 L
440 VΔ	60 Hz output	<b>L2X</b>	56 ... 225	100 ... 160	56 ... 200	180 ... 315 L	63 ... 200	180 ... 315 L
460 VY	50 Hz output	<b>L2S</b>	56 ... 225	100 ... 160	56 ... 200	180 ... 315 M	63 ... 200	180 ... 315 L
460 VY	60 Hz output	<b>L2E</b>	56 ... 225	100 ... 160	56 ... 200	180 ... 315 M	63 ... 200	180 ... 315 L
460 VΔ	50 Hz output	<b>L2T</b>	56 ... 225	100 ... 160	56 ... 200	180 ... 315 L	63 ... 200	180 ... 315 L
460 VΔ	60 Hz output	<b>L2F</b>	56 ... 225	100 ... 160	56 ... 200	180 ... 315 L	63 ... 200	180 ... 315 L
575 VY	50 Hz output	<b>L2U</b>	56 ... 225	100 ... 160	56 ... 200	180 ... 315 M	63 ... 200	180 ... 315 L
575 VY	60 Hz output	<b>L2L</b>	56 ... 225	100 ... 160	56 ... 200	180 ... 315 M	63 ... 200	180 ... 315 L
575 VΔ	50 Hz output	<b>L2V</b>	56 ... 225	100 ... 160	56 ... 200	180 ... 315 L	63 ... 200	180 ... 315 L
575 VΔ	60 Hz output	<b>L2M</b>	56 ... 225	100 ... 160	56 ... 200	180 ... 315 L	63 ... 200	180 ... 315 L

Voltage at <b>60 Hz</b>	Required output at <b>60 Hz</b>	Order code for <b>60 Hz motors multi-voltage</b>	Frame sizes for motors					
			1LA5, 1LA7	1LA6	1LA9	1LG4, 1LG6	1LP5, 1LP7	1LP4
230 VYY/460 VY 60 Hz	50 Hz output	<b>L3E</b>	56 ... 200	–	56 ... 200	–	63 ... 200	–
230 VYY/460 VY 60 Hz	60 Hz output	<b>L3F</b>	56 ... 200	–	56 ... 200	–	63 ... 200	–
230 VΔΔ/460 VΔ 60 Hz	50 Hz output	<b>L3G</b>	100 ... 200	–	100 ... 200	–	100 ... 200	–
230 VΔΔ/460 VΔ 60 Hz	60 Hz output	<b>L3H</b>	100 ... 200	–	100 ... 200	–	100 ... 200	–

Voltage at <b>60 Hz</b>	Required output at <b>60 Hz</b>	Order code for <b>60 Hz motors pole-changing</b>	Frame sizes for motors					
			1LA5, 1LA7	1LA6	1LA9	1LG4, 1LG6	1LP5, 1LP7	1LP4
220 V	50 Hz output	<b>L4A</b>	63 ... 200	–	–	–	–	–
220 V	60 Hz output	<b>L4B</b>	63 ... 200	–	–	–	–	–
380 V	50 Hz output	<b>L4C</b>	63 ... 200	–	–	–	–	–
380 V	60 Hz output	<b>L4D</b>	63 ... 200	–	–	–	–	–
440 V	50 Hz output	<b>L4G</b>	63 ... 200	–	–	–	–	–
440 V	60 Hz output	<b>L4E</b>	63 ... 200	–	–	–	–	–
460 V	50 Hz output	<b>L4J</b>	63 ... 200	–	–	–	–	–
460 V	60 Hz output	<b>L4H</b>	63 ... 200	–	–	–	–	–
575 V	50 Hz output	<b>L4N</b>	63 ... 200	–	–	–	–	–
575 V	60 Hz output	<b>L4M</b>	63 ... 200	–	–	–	–	–

<sup>1)</sup> For order codes **L1A, L1B, L1C, L1D, L1E, L1L, L1R** and **L1U**, a rated voltage range is also included on the rating plate.

<sup>2)</sup> For the order code **L1R** a voltage of 440 VY 60 Hz is also possible for 1LA5, 1LA7, 1LA9, 1LP5 and 1LP7 motor series.

<sup>3)</sup> For the order code **L1L** a voltage of 440 VΔ 60 Hz is also possible for 1LA5, 1LA7, 1LA9, 1LP5 and 1LP7 motor series.

# IEC Squirrel-Cage Motors

## Introduction motors 1LA, 1LG, 1LL, 1LP, 1MA, 1MJ, 1PP, 1PQ

### General technical data

#### Further voltages for non-standard motors

Voltage at 60 Hz	Required output at 60 Hz	Order code for 60 Hz constant-speed motors (not pole-changing)	Frame sizes for motors		
			1LA8	1PQ8	1LL8
220 VΔ/380 VY	50 Hz output	<b>L2A</b>	–	–	–
220 VΔ/380 VY	60 Hz output	<b>L2B</b>	–	–	–
380 VΔ/660 VY	50 Hz output	<b>L2C</b>	315 ... 450	315 ... 450	315 ... 450
380 VΔ/660 VY	60 Hz output	<b>L2D</b>	315 ... 450	315 ... 450	315 ... 450
440 VY	50 Hz output	<b>L2Q</b>	–	–	–
440 VY	60 Hz output	<b>L2W</b>	–	–	–
440 VΔ	50 Hz output	<b>L2R</b>	315 ... 450	315 ... 450	315 ... 450
440 VΔ	60 Hz output	<b>L2X</b>	315 ... 450	315 ... 450	315 ... 450
460 VY	50 Hz output	<b>L2S</b>	–	–	–
460 VY	60 Hz output	<b>L2E</b>	–	–	–
460 VΔ	50 Hz output	<b>L2T</b>	315 ... 450	315 ... 450	315 ... 450
460 VΔ	60 Hz output	<b>L2F</b>	315 ... 450	315 ... 450	315 ... 450
575 VY	50 Hz output	<b>L2U</b>	–	–	–
575 VY	60 Hz output	<b>L2L</b>	–	–	–
575 VΔ	50 Hz output	<b>L2V</b>	315 ... 450	315 ... 450	315 ... 450
575 VΔ	60 Hz output	<b>L2M</b>	315 ... 450	315 ... 450	315 ... 450

#### Further voltages for explosion-proof motors

Voltage at 50 Hz	Required output at 50 Hz	Order code for 50 Hz constant-speed motors (not pole-changing)	Frame sizes for motors						
			1LA5, 1LA7	1LA6	1LA9	1LG4, 1LG6	1MA6, 1MA7 <sup>2)</sup>	1MJ6	1MJ7
220 VΔ/380 VY <sup>3)</sup> (210 ... 230 VΔ/ 360 ... 400 VY)	50 Hz output	<b>L1R</b>	56 ... 225	100 ... 160	56 ... 200	180 ... 315 M	63 ... 315 M	71 ... 200	225 ... 315 M
230 VΔ (220 ... 240 VΔ)	50 Hz output	<b>L1E</b>	56 ... 225	100 ... 160	56 ... 200	180 ... 315 M	63 ... 315 M	71 ... 200	225 ... 315 M
380 VΔ/660 VY <sup>4)</sup> (360 ... 400 VΔ/ 625 ... 695 VY)	50 Hz output	<b>L1L</b>	56 ... 225	100 ... 160	56 ... 200	180 ... 315 L	71 ... 315 L	71 ... 200	225 ... 315 M
415 VY (395 ... 435 VY)	50 Hz output	<b>L1C</b>	56 ... 225	100 ... 160	56 ... 200	180 ... 315 M	63 ... 315 M	71 ... 200	225 ... 315 M
415 VΔ (395 ... 435 VΔ)	50 Hz output	<b>L1D</b>	56 ... 225	100 ... 160	56 ... 200	180 ... 315 L	71 ... 315 L	71 ... 200	225 ... 315 M
400 VY (380 ... 420 VY)	50 Hz output	<b>L1A</b>	56 ... 225	100 ... 160	56 ... 200	180 ... 315 M	–	–	–
400 VΔ (380 ... 420 VΔ)	50 Hz output	<b>L1B</b> <sup>5)</sup>	56 ... 225	100 ... 160	56 ... 200	180 ... 315 L	–	–	–
400 VΔ (460 VΔ at 60 Hz) (380 ... 420 VΔ)	50 Hz output	<b>L1U</b>	56 ... 225	100 ... 160	56 ... 200	180 ... 315 L	–	–	–
400 VΔ (only 4-8-pole)	87 Hz output	<b>L3A</b>	56 ... 225	100 ... 160	56 ... 200	180 ... 315 M	–	–	–

Voltage at 60 Hz	Required output at 60 Hz	Order code for 60 Hz constant-speed motors (not pole-changing)	Frame sizes for motors						
			1LA5, 1LA7	1LA6	1LA9	1LG4, 1LG6	1MA6, 1MA7 <sup>6)</sup>	1MJ6	1MJ7
220 VΔ/380 VY	50 Hz output	<b>L2A</b>	56 ... 225	100 ... 160	56 ... 200	180 ... 315 M	63 ... 315 M	71 ... 200	225 ... 315 M
220 VΔ/380 VY	60 Hz output	<b>L2B</b>	56 ... 225	100 ... 160	56 ... 200	180 ... 315 M	–	71 ... 200	225 ... 315 M
380 VΔ/660 VY	50 Hz output	<b>L2C</b>	56 ... 225	100 ... 160	56 ... 200	180 ... 315 L	63 ... 315 L	71 ... 200	225 ... 315 M
380 VΔ/660 VY	60 Hz output	<b>L2D</b>	56 ... 225	100 ... 160	56 ... 200	180 ... 315 L	–	71 ... 200	225 ... 315 M
440 VY	50 Hz output	<b>L2Q</b>	56 ... 225	100 ... 160	56 ... 200	180 ... 315 M	63 ... 315 M	71 ... 200	225 ... 315 M
440 VY	60 Hz output	<b>L2W</b>	56 ... 225	100 ... 160	56 ... 200	180 ... 315 M	–	71 ... 200	225 ... 315 M
440 VΔ	50 Hz output	<b>L2R</b>	56 ... 225	100 ... 160	56 ... 200	180 ... 315 L	63 ... 315 L	71 ... 200	225 ... 315 M
440 VΔ	60 Hz output	<b>L2X</b>	56 ... 225	100 ... 160	56 ... 200	180 ... 315 L	–	71 ... 200	225 ... 315 M
460 VY	50 Hz output	<b>L2S</b>	56 ... 225	100 ... 160	56 ... 200	180 ... 315 M	63 ... 315 M	71 ... 200	225 ... 315 M
460 VY	60 Hz output	<b>L2E</b>	56 ... 225	100 ... 160	56 ... 200	180 ... 315 M	–	71 ... 200	225 ... 315 M
460 VΔ	50 Hz output	<b>L2T</b>	56 ... 225	100 ... 160	56 ... 200	180 ... 315 L	63 ... 315 L	71 ... 200	225 ... 315 M
460 VΔ	60 Hz output	<b>L2F</b>	56 ... 225	100 ... 160	56 ... 200	180 ... 315 L	–	71 ... 200	225 ... 315 M
575 VY	50 Hz output	<b>L2U</b>	56 ... 225	100 ... 160	56 ... 200	180 ... 315 M	63 ... 315 M	71 ... 200	225 ... 315 M
575 VY	60 Hz output	<b>L2L</b>	56 ... 225	100 ... 160	56 ... 200	180 ... 315 M	–	71 ... 200	225 ... 315 M
575 VΔ	50 Hz output	<b>L2V</b>	56 ... 225	100 ... 160	56 ... 200	180 ... 315 L	63 ... 315 L	71 ... 200	225 ... 315 M
575 VΔ	60 Hz output	<b>L2M</b>	56 ... 225	100 ... 160	56 ... 200	180 ... 315 L	–	71 ... 200	225 ... 315 M

1) For order codes **L1A**, **L1C**, **L1D**, **L1E**, **L1L**, **L1R** and **L1U**, a rated voltage range is also included on the rating plate, with the exception of versions in Zone 2 type of protection "n" or Ex n II T3.

2) For further information on the rated voltage range see Page 4/84.

3) For the order code **L1R** a voltage of 440 VY 60 Hz is also possible for 1LA5, 1LA7, 1LA9, 1LP5 and 1LP7 motor series.

4) For the order code **L1L** a voltage of 440 VΔ 60 Hz is also possible for 1LA5, 1LA7, 1LA9, 1LP5 and 1LP7 motor series.

5) For converter-fed operation, the converter output for a voltage according to the table is included on the rating plate.

6) A special certificate is required.

# IEC Squirrel-Cage Motors

## Introduction motors 1LA, 1LG, 1LL, 1LP, 1MA, 1MJ, 1PP, 1PQ

### General technical data

#### Further voltages for fan motors

Voltage at 50 Hz	Required output at 50 Hz	Order code for 50 Hz constant-speed motors (not pole-changing) <sup>1)</sup>	Frame sizes for motors	
			1PP5, 1PP7	1PP4
220 VΔ/380 VY <sup>2)</sup> (210 ... 230 VΔ/ 360 ... 400 VY)	50 Hz output	<b>L1R</b>	63 ... 200	180 ... 315 M
230 VΔ (220 ... 240 VΔ)	50 Hz output	<b>L1E</b>	63 ... 200	180 ... 315 M
380 VΔ/660 VY <sup>3)</sup> (360 ... 400 VΔ/ 625 ... 695 VY)	50 Hz output	<b>L1L</b>	63 ... 200	180 ... 315 L
415 VY (395 ... 435 VY)	50 Hz output	<b>L1C</b>	63 ... 200	180 ... 315 M
415 VΔ (395 ... 435 VΔ)	50 Hz output	<b>L1D</b>	63 ... 200	180 ... 315 L
400 VY (380 ... 420 VY)	50 Hz output	<b>L1A</b>	63 ... 200	180 ... 315 M
400 VΔ (380 ... 420 VΔ)	50 Hz output	<b>L1B</b>	63 ... 200	180 ... 315 L
400 VΔ (460 VΔ at 60 Hz) (380 ... 420 VΔ)	50 Hz output	<b>L1U</b>	63 ... 200	180 ... 315 L

Voltage at 60 Hz	Required output at 60 Hz	Order code for 60 Hz constant-speed motors (not pole-changing)	Frame sizes for motors	
			1PP5, 1PP7	1PP4
220 VΔ/380 VY	50 Hz output	<b>L2A</b>	63 ... 200	180 ... 315 M
220 VΔ/380 VY	60 Hz output	<b>L2B</b>	63 ... 200	180 ... 315 M
380 VΔ/660 VY	50 Hz output	<b>L2C</b>	63 ... 200	180 ... 315 L
380 VΔ/660 VY	60 Hz output	<b>L2D</b>	63 ... 200	180 ... 315 L
440 VY	50 Hz output	<b>L2Q</b>	63 ... 200	180 ... 315 M
440 VY	60 Hz output	<b>L2W</b>	63 ... 200	180 ... 315 M
440 VΔ	50 Hz output	<b>L2R</b>	63 ... 200	180 ... 315 L
440 VΔ	60 Hz output	<b>L2X</b>	63 ... 200	180 ... 315 L
460 VY	50 Hz output	<b>L2S</b>	63 ... 200	180 ... 315 M
460 VY	60 Hz output	<b>L2E</b>	63 ... 200	180 ... 315 M
460 VΔ	50 Hz output	<b>L2T</b>	63 ... 200	180 ... 315 L
460 VΔ	60 Hz output	<b>L2F</b>	63 ... 200	180 ... 315 L
575 VY	50 Hz output	<b>L2U</b>	63 ... 200	180 ... 315 M
575 VY	60 Hz output	<b>L2L</b>	63 ... 200	180 ... 315 M
575 VΔ	50 Hz output	<b>L2V</b>	63 ... 200	180 ... 315 L
575 VΔ	60 Hz output	<b>L2M</b>	63 ... 200	180 ... 315 L

Voltage at 60 Hz	Required output at 60 Hz	Order code for 60 Hz motors, multi-voltage	Frame sizes for motors	
			1PP5, 1PP7	1PP4
230 VYY/460 VY 60 Hz	50 Hz output	<b>L3E</b>	63 ... 200	–
230 VYY/460 VY 60 Hz	60 Hz output	<b>L3F</b>	63 ... 200	–
230 VΔΔ/460 VΔ 60 Hz	50 Hz output	<b>L3G</b>	100 ... 200	–
230 VΔΔ/460 VΔ 60 Hz	60 Hz output	<b>L3H</b>	100 ... 200	–

Voltage at 60 Hz	Required output at 60 Hz	Order code for 60 Hz motors, pole-changing	Frame sizes for motors	
			1LA5, 1LA7	1LG4
220 V	50 Hz output	<b>L4A</b>	80 ... 200	180 ... 280
220 V	60 Hz output	<b>L4B</b>	80 ... 200	180 ... 280
380 V	50 Hz output	<b>L4C</b>	80 ... 200	180 ... 280
380 V	60 Hz output	<b>L4D</b>	80 ... 200	180 ... 280
440 V	50 Hz output	<b>L4G</b>	80 ... 200	180 ... 280
440 V	60 Hz output	<b>L4E</b>	80 ... 200	180 ... 280
460 V	50 Hz output	<b>L4J</b>	80 ... 200	180 ... 280
460 V	60 Hz output	<b>L4H</b>	80 ... 200	180 ... 280
575 V	50 Hz output	<b>L4N</b>	80 ... 200	180 ... 280
575 V	60 Hz output	<b>L4M</b>	80 ... 200	180 ... 280

<sup>1)</sup> For order codes **L1A**, **L1B**, **L1C**, **L1D**, **L1E**, **L1L**, **L1R** and **L1U** a rated voltage range is also included on the rating plate.

<sup>2)</sup> For the order code **L1R** a voltage of 440 VY 60 Hz is also possible for 1PP5 and 1PP7 motor series.

<sup>3)</sup> For the order code **L1L** a voltage of 440 VΔ 60 Hz is also possible for 1PP5 and 1PP7 motor series.

# IEC Squirrel-Cage Motors

## Introduction motors 1LA, 1LG, 1LL, 1LP, 1MA, 1MJ, 1PP, 1PQ

### General technical data

Rated currents for rated voltage range 380 V to 420 V at 50 Hz

	Currents for voltage and number of poles							
	380 V		420 V		380 V		420 V	
	2-pole A	A	4-pole A	A	6-pole A	A	8-pole A	A
<b>1LA7, 1LA5 motors</b>								
1LA7 050	0.27	0.26	0.21	0.21	–	–	–	–
1LA7 053	0.33	0.32	0.30	0.31	–	–	–	–
1LA7 060	0.52	0.53	0.42	0.44	–	–	–	–
1LA7 063	0.69	0.71	0.58	0.59	0.48	0.5	–	–
1LA7 070	1.05	1.02	0.80	0.77	0.66	0.64	0.36	0.36
1LA7 073	1.38	1.41	1.07	1.06	0.80	0.80	0.51	0.52
1LA7 080	1.75	1.79	1.50	1.50	1.18	1.25	0.73	0.80
1LA7 083	2.45	2.50	2.12	2.17	1.62	1.66	1.01	1.10
1LA7 090	3.40	3.35	2.60	2.60	2.10	2.15	1.15	1.18
1LA7 096	4.70	4.65	3.50	3.50	3.0	2.95	1.63	1.60
1LA7 106	6.25	6.15	4.8	4.8	4.0	4.1	2.25	2.2
1LA7 107	–	–	6.5	6.8	–	–	3.0	3.0
1LA7 113	8.2	7.7	8.4	8.3	5.4	5.3	4.1	4.2
1LA7 130	10.6	10.4	11.4	11.9	7.3	7.5	5.9	6.0
1LA7 131	14.1	13.8	–	–	–	–	–	–
1LA7 133	–	–	15.4	15.5	9.5	9.7	7.9	7.9
1LA7 134	–	–	–	–	13.0	13.1	–	–
1LA7 163	21.0	20.5	22.3	21.5	17.5	17.3	9.9	10.6
1LA7 164	28.0	26.0	–	–	–	–	13.1	13.4
1LA7 166	34.0	32.0	29.5	28.5	24.8	24.7	17.6	18.4
1LA5 183	40	38	36	35	–	–	–	–
1LA5 186	–	–	42	41	32.7	31	26.5	23.5
1LA5 206	55	52	–	–	40	38.5	–	–
1LA5 207	67	64	57	54	46.5	45.5	34	31
1LA5 220	–	–	69	64	–	–	40	37
1LA5 223	81	76	84	78	64	63	47	43
<b>1LA6, 1LG4 motors</b>								
1LA6 106	6.25	6.15	4.8	4.8	4.0	4.1	2.25	2.2
1LA6 107	–	–	6.5	6.8	–	–	3.0	3.0
1LA6 113	8.2	7.7	8.4	8.3	5.4	5.3	4.1	4.2
1LA6 130	10.6	10.4	11.4	11.9	7.3	7.5	5.9	6.0
1LA6 131	14.1	13.8	–	–	–	–	–	–
1LA6 133	–	–	15.4	15.5	9.5	9.7	7.9	7.9
1LA6 134	–	–	–	–	13.0	13.1	–	–
1LA6 163	21.0	20.5	22.3	21.5	17.5	17.3	9.9	10.6
1LA6 164	28.0	26.0	–	–	–	–	13.1	13.4
1LA6 166	34.0	32.0	29.5	28.5	24.8	24.7	17.6	18.4
1LG4 183	41.5	40	36	35	–	–	–	–
1LG4 186	–	–	42.5	41.5	30.5	28.5	25.5	25
1LG4 188	56	54	59	60	38.5	37	34.5	34.5
1LG4 206	56	52	–	–	37	37	–	–
1LG4 207	67	63	57	55	45	42.5	33.5	32
1LG4 208	82	77	70	69	61	60	40.5	39
1LG4 220	–	–	72	65	–	–	40.5	36.5
1LG4 223	83	75	85	77	60	54	46.5	42
1LG4 228	100	90	104	94	73	66	64	58
1LG4 253	100	93	104	98	73	68	60	57
1LG4 258	134	128	138	134	87	81	73	69
1LG4 280	136	126	144	132	87	80	76	70
1LG4 283	162	150	168	156	106	97	92	84
1LG4 288	196	182	204	190	146	134	112	102
1LG4 310	198	188	205	194	142	136	110	104
1LG4 313	230	215	245	230	170	162	146	136
1LG4 316	280	255	295	275	205	190	174	164
1LG4 317	345	315	360	330	245	225	210	198
1LG4 318	–	–	–	–	295	275	250	240

# IEC Squirrel-Cage Motors

## Introduction motors 1LA, 1LG, 1LL, 1LP, 1MA, 1MJ, 1PP, 1PQ

### General technical data

	Currents for voltage and number of poles							
	380 V 2-pole	420 V	380 V 4-pole	420 V	380 V 6-pole	420 V	380 V 8-pole	420 V
	A	A	A	A	A	A	A	A
<b>1LG6, 1LA8 motors</b>								
<b>1LG6 183</b>	40.5	37.5	36	34.5	–	–	–	–
<b>1LG6 186</b>	–	–	42.5	40.5	30.5	29	24.5	23
<b>1LG6 206</b>	54	51	–	–	37	35.5	–	–
<b>1LG6 207</b>	66	62	56	54	44	40.5	32.5	30.5
<b>1LG6 220</b>	–	–	70	64	–	–	38	34.5
<b>1LG6 223</b>	81	73	84	76	59	53	45	41
<b>1LG6 253</b>	97	90	99	94	72	67	59	55
<b>1LG6 280</b>	134	124	138	128	85	79	75	69
<b>1LG6 283</b>	158	146	166	154	104	96	91	83
<b>1LG6 310</b>	192	174	200	184	142	134	106	100
<b>1LG6 313</b>	230	210	235	215	166	156	142	136
<b>1LG6 316</b>	275	250	285	265	205	190	170	158
<b>1LG6 317</b>	340	305	355	330	245	225	205	194
<b>1LG6 318</b>	–	–	–	–	290	275	250	230
<b>1LA8 315</b>	435	400	450	425	360	340	310	295
<b>1LA8 317</b>	540	495	560	530	450	420	385	365
<b>1LA8 353</b>	620	570	640	590	–	–	–	–
<b>1LA8 355</b>	690	630	720	680	570	530	480	455
<b>1LA8 357</b>	860	790	880	820	720	670	600	560
<b>1LA8 403</b>	950	880	990	930	810	760	680	640
<b>1LA8 405</b>	1080	990	1100	1040	890	840	760	720
<b>1LA8 407</b>	690 <sup>1)</sup>	640 <sup>2)</sup>	710 <sup>1)</sup>	670 <sup>2)</sup>	1000	940	850	810
<b>1LA8 453</b>	780 <sup>1)</sup>	730 <sup>2)</sup>	810 <sup>1)</sup>	750 <sup>2)</sup>	1160	1060	960	910
<b>1LA8 455</b>	880 <sup>1)</sup>	810 <sup>2)</sup>	910 <sup>1)</sup>	860 <sup>2)</sup>	740 <sup>1)</sup>	690 <sup>2)</sup>	1080	1020
<b>1LA8 457</b>	970 <sup>1)</sup>	890 <sup>2)</sup>	1000 <sup>1)</sup>	940 <sup>2)</sup>	830 <sup>1)</sup>	770 <sup>2)</sup>	1200	1140

The rating plates of 1MJ6 motors specify the maximum current in the voltage range in addition to the rated current. This maximum is approximately 5 % higher than the rated current.

<sup>1)</sup> Only available for 690 V, see catalog part 3 "Non-standard motors frame size 315 and above"; but in 660 V design.

<sup>2)</sup> Only available for 690 V, see catalog part 3 "Non-standard motors frame size 315 and above"; but in 725 V design.

# IEC Squirrel-Cage Motors

## Introduction motors 1LA, 1LG, 1LL, 1LP, 1MA, 1MJ, 1PP, 1PQ

### General technical data

#### Outputs

The outputs and the rated outputs are listed in the selection tables and in the separate catalog parts for 50 Hz and in most

Table of rated output at 60 Hz for single-speed motors

Motor type	Admissible output at 60 Hz for voltages between 220 V or 380 V and 725 V			
	2-pole kW	4-pole kW	6-pole kW	8-pole kW
<b>1LA6, 1LG4, 1LG6, 1LA7, 1MJ6, 1MJ7 motors</b>				
1LA7 050 – –	0.105	0.07	–	–
1LA7 053 – –	0.14	0.105	–	–
1LA7 060 – –	0.21	0.14	–	–
1LA7 063 – –	0.29	0.21	0.1	–
1LA7 070 – 1MJ6 070	0.43	0.29	0.21	0.1
1LA7 073 – 1MJ6 073	0.63	0.43	0.29	0.14
1LA7 080 – 1MJ6 080	0.86	0.63	0.43	0.21
1LA7 083 – 1MJ6 083	1.3	0.86	0.63	0.29
1LA7 090 – 1MJ6 096	1.75	1.3	0.86	0.43
1LA7 096 – 1MJ6 097	2.55	1.75	1.3	0.63
1LA7 106 1LA6 106 1MJ6 106	3.45	2.55	1.75	0.86
1LA7 107 1LA6 107 1MJ6 107	–	3.45	–	1.3
1LA7 113 1LA6 113 1MJ6 113	4.6	4.6	2.55	1.75
1LA7 130 1LA6 130 1MJ6 130	6.3	6.3	3.45	2.55
1LA7 131 1LA6 131 1MJ6 131	8.6	–	–	–
1LA7 133 1LA6 133 1MJ6 133	–	8.6	4.6	3.45
1LA7 134 1LA6 134 1MJ6 134	–	–	6.3	–
1LA7 163 1LA6 163 1MJ6 163	12.6	12.6	8.6	4.6
1LA7 164 1LA6 164 1MJ6 164	17.3	–	–	6.3
1LA7 166 1LA6 166 1MJ6 166	21.3	17.3	12.6	8.6
1LA5 183 1LG . 183 1MJ6 183	24.5	21.3	–	–
1LA5 186 1LG . 186 1MJ6 186	–	25.3	18	3.2
– 1LG . 188 –	33.5	34.5	22	18
1LA5 206 1LG . 206 1MJ6 206	33.5	–	22	–
1LA5 207 1LG . 207 1MJ6 207	41.5	34.5	26.5	18
– 1LG . 208 –	51	42.5	36	22
1LA5 220 1LG . 220 1MJ7 220	–	42.5	–	22
1LA5 223 1LG . 223 1MJ7 223	51	52	36	26.5
– 1LG . 228 –	62	63	44.5	36
– 1LG . 253 1MJ7 253	62	63	44.5	36
– 1LG . 258 –	84	86	54	44.5
– 1LG . 280 1MJ7 280	84	86	54	44.5
– 1LG . 283 1MJ7 283	101	104	66	54
– 1LG . 288 –	123	127	90	66
– 1LG . 310 1MJ7 310	123	127	90	66
– 1LG . 313 1MJ7 313	148	152	108	90
– 1LG . 316 –	180	184	132	108
– 1LG . 317 –	224	230	158	132
– 1LG . 318 –	–	–	192	158

Table of rated output at 60 Hz for pole-changing motors

At 60 Hz, the output can be increased in accordance with the factors listed in the table below. The output is increased separately for each number of poles, i.e. for 6/4-pole motors, frame sizes 180 to 315, 60 Hz, the 6-pole output can be increased by 20 % and the 4-pole output can be increased by 15 %.

Possible versions of 2-pole motors

Frame size	Horizontal type of construction			Vertical type of construction		
	50 Hz with foot	60 Hz with foot	50 Hz with flange	60 Hz with flange	50 Hz	60 Hz
56 to 315 M	•	•	•	•	•	•
315 L	•	•	–	–	•	•
315	•	•	•	•	•	•
355 and 400	•	•	•	•	•	–
450	•	–	•	–	•	–

cases also for 60 Hz. For 60 Hz, the rated output values must, in some cases, be increased, e.g. for pole-changing motors.

Motor type	Admissible output at 60 Hz for voltages between 380 V and 725 V			
	2-pole kW	4-pole kW	6-pole kW	8-pole kW
<b>1LA8 motors</b>				
1LA8 315 – –	280	288	230	184
1LA8 317 – –	353	362	288	230
1LA8 353 – –	398	408	–	–
1LA8 355 – –	448	460	362	288
1LA8 357 – –	560	575	460	362
1LA8 403 – –	616	644	518	408
1LA8 405 – –	693	725	575	460
1LA8 407 – –	–	817	644	518
1LA8 453 – –	–	–	725	575
1LA8 455 – –	–	–	–	644
1LA8 457 – –	–	–	–	725

The speed increases to approx. 120 % in relation to 50 Hz motors.

Higher outputs/voltages are available on request!

Frame size	Number of poles	Factor for increased output at 60 Hz for voltages between 220 or 380 and 725 V
56 to 160	2 to 8	1.15
180 to 315	2	1.12
	4	1.15
	6 and 8	1.2

## General technical data

Assignment of the standard power kW-HP and vice versa in accordance with IEC

$$\text{kW} \cdot 1,341 = \text{HP}$$

$$\text{HP} \cdot 0,746 = \text{kW}$$

$P_{\text{rated}}$ kW	$P_{\text{rated}}$ HP	$P_{\text{rated}}$ kW	$P_{\text{rated}}$ HP	$P_{\text{rated}}$ kW	$P_{\text{rated}}$ HP	$P_{\text{rated}}$ kW	$P_{\text{rated}}$ HP	$P_{\text{rated}}$ kW	$P_{\text{rated}}$ HP	$P_{\text{rated}}$ kW	$P_{\text{rated}}$ HP
0.06	0.08	0.37	0.5	2.2	3	11	15	37	50	110	150
0.09	0.12	0.55	0.75	3	4	15	20	45	60	132	200
0.12	0.16	0.75	1	4	5	18.5	25	55	75	160	250
0.18	0.25	1.1	1.5	5.5	7.5	22	30	75	100	200	300
0.25	0.33	1.5	2	7.5	10	30	40	90	125		

### Efficiency, power factor, rated torque, rated speed and direction of rotation

#### Efficiency and power factor

The efficiency  $\eta$  and power factor  $\cos \varphi$  for each rated output are listed in the selection tables in the individual sections of this catalog.

For EFF1 and EFF2 motors, the 3/4 load efficiency is also indicated.

Part-load efficiency % at					
1/4	1/2	3/4	4/4	5/4	
of full load					
93	96	97	<b>97</b>	96.5	
92	95	96	<b>96</b>	95.5	
90	93.5	95	<b>95</b>	94.5	
89	92.5	94	<b>94</b>	93.5	
88	91.5	93	<b>93</b>	92.5	
87	91	92	<b>92</b>	91.5	
86	90	91	<b>91</b>	90	
85	89	90	<b>90</b>	89	
84	88	89	<b>89</b>	88	
80	87	88	<b>88</b>	87	
79	86	87	<b>87</b>	86	
78	85	86	<b>86</b>	85	
76	84	85	<b>85</b>	83.5	
74	83	84	<b>84</b>	82.5	
72	82	83	<b>83</b>	81.5	
70	81	82	<b>82</b>	80.5	
68	80	81	<b>81</b>	79.5	
66	79	80	<b>80</b>	78.5	
64	77	79.5	<b>79</b>	77.5	
62	75.5	78.5	<b>78</b>	76.5	
60	74	77.5	<b>77</b>	75	
58	73	76	<b>76</b>	74	
56	72	75	<b>75</b>	73	
55	71	74	<b>74</b>	72	
54	70	73	<b>73</b>	71	
53	68	72	<b>72</b>	70	
52	67	71	<b>71</b>	69	
51	66	70	<b>70</b>	68	
50	65	69	<b>69</b>	67	
49	64	67.5	<b>68</b>	66	
48	62	66.5	<b>67</b>	65	
47	61	65	<b>66</b>	64	
46	60	64	<b>65</b>	63	
45	59	63	<b>64</b>	62	
44	57	62	<b>63</b>	61	
43	56	60.5	<b>62</b>	60.5	
42	55	59.5	<b>61</b>	59.5	
41	54	58.5	<b>60</b>	58.5	

The part-load values stated in the tables below are averages; precise values can be provided on request.

Part-load power factor at				
1/4	1/2	3/4	4/4	5/4
of full load				
0.70	0.86	0.90	<b>0.92</b>	0.92
0.65	0.85	0.89	<b>0.91</b>	0.91
0.63	0.83	0.88	<b>0.90</b>	0.90
0.61	0.80	0.86	<b>0.89</b>	0.89
0.57	0.78	0.85	<b>0.88</b>	0.88
0.53	0.76	0.84	<b>0.87</b>	0.87
0.51	0.75	0.83	<b>0.86</b>	0.86
0.49	0.73	0.81	<b>0.85</b>	0.86
0.47	0.71	0.80	<b>0.84</b>	0.85
0.45	0.69	0.79	<b>0.83</b>	0.84
0.43	0.67	0.77	<b>0.82</b>	0.83
0.41	0.66	0.76	<b>0.81</b>	0.82
0.40	0.65	0.75	<b>0.80</b>	0.81
0.38	0.63	0.74	<b>0.79</b>	0.80
0.36	0.61	0.72	<b>0.78</b>	0.80
0.34	0.59	0.71	<b>0.77</b>	0.79
0.32	0.58	0.70	<b>0.76</b>	0.78
0.30	0.56	0.69	<b>0.75</b>	0.78
0.29	0.55	0.68	<b>0.74</b>	0.77
0.28	0.54	0.67	<b>0.73</b>	0.77
0.27	0.52	0.63	<b>0.72</b>	0.76
0.26	0.50	0.62	<b>0.71</b>	0.76

#### Rated torque

The rated torque in Nm delivered at the motor shaft is

$$M = \frac{9.55 \cdot P \cdot 1000}{n}$$

$P$  Rated output in kW

$n$  Speed in rpm

#### Note:

If the voltage deviates from its rated value within the allowed limits, the locked-rotor torque, the pull-up torque and the breakdown torque vary with the approximate square of the value, but the locked-rotor current varies approximately linearly.

In the case of squirrel-cage motors, the locked-rotor torque and breakdown torque are listed in the selection tables as multiples of the rated torque.

The normal practise is to start squirrel-cage motors directly on line. The torque class indicates that with direct-on-line starting, even if there is – 5 % undervoltage, it is possible to start up the motor against a load torque of

- 160 % for CL 16
- 130 % for CL 13
- 100 % for CL 10
- 70 % for CL 7
- 50 % for CL 5

of the rated torque.

The individual torque characteristics are available in the SD configurator. In addition, it is possible to perform calculations with the supplied start-up program.

⚠ For type 1MA motors in the standard design for T1/T2 and T3 and different rated outputs, the torque class specified for the higher output applies.

# IEC Squirrel-Cage Motors

## Introduction motors 1LA, 1LG, 1LL, 1LP, 1MA, 1MJ, 1PP, 1PQ

### General technical data

#### Rated speed and direction of rotation

The rated speeds are applicable for the rated data. The synchronous speed changes proportionally with the line frequency. The motors are suitable for clockwise and counter-clockwise rotation.

This does not apply to the following 2-pole motors:

- 1LA8, 1LL8 frame size 355 and above for clockwise rotation only; alternatively order code **K38** for counter-clockwise rotation only
- 1LA8, 1MJ6, 1MA6 and 1LG4 in VIK version from frame size 315 and above.

If U1, V1, W1 are connected to L1, L2, L3, clockwise rotation results as viewed onto the drive-end shaft extension. Counter-clockwise rotation is achieved by swapping two phases (see also "Heating and ventilation").

#### Rating plate and extra rating plates

DIN EN 60034-1 lays down that the approximate total weight for all motors from frame size 90 (from approx. 30 kg) is indicated on the rating plate.

An extra rating plate can be supplied loose for all motors, order code **K31**.  
Supplementary data can be indicated on the rating plate or extra rating plate and on the packaging label (maximum of 20 characters), order code **Y84**.

An extra rating plate can also be supplied for the identification code, order code **Y82**.

An extra rating plate or a rating plate can also be ordered with different rating plate data, order code **Y80**.

An extra rating plate can be supplied loose for all motors of frame sizes 100 to 315, order code **B06**.

In the standard version, the rating plate is available in international format or in the English/German language. The language for the rating plate can be ordered by specifying in plain text. An overview of the languages that can be ordered, at additional cost in some cases, is provided by the table below.

 In addition, for 1MA motors:

With the exception of 2-pole motors from frame size 225 M or larger, all motors are suitable for both T1/T2 and T3 (uniform design).

If the rated output for T1/T2 differs from that of T3, the data for both output values is stated separately.

#### Overview of the languages on the rating plate

Motor type	Frame size	Rating plate							Double rating plate 50 Hz and 60 Hz data for		
		Inter- national	German (de)	English (en)	German (de)/ English (en)	French (fr)/ Spanish (es)	Italian (it)	Portuguese (pt)	Russian (ru)	500 VY and 575 VY	230 VΔ/ 400 VY and 460 VY  500 VΔ and 575 VΔ
1LA5	180 ... 225	☐		○						☐	☐
1LA6	100 ... 160	☐		○						☐	☐
1LA7	56 ... 160	☐		○						☐	☐
1LA8	315 ... 450				☐	○	○	○			
1LA9	56 ... 200	☐		○						☐	☐
1LG4	180 ... 315				☐				✓		☐
1LG6	180 ... 315	☐							✓		☐
1LL8	315 ... 450				☐	○	○	○			
1LP4	180 ... 315				☐				✓		☐
1LP5	63 ... 160	☐		○						☐	☐
1LP7	180 ... 200	☐		○						☐	☐
1MA6	100 ... 180			○	☐						
1MA6	180 ... 200			○	☐						
1MA6	225 ... 315			○	☐	○	○	○	✓		
1MA7	63 ... 160	☐		○							☐
1MJ6	71 ... 200	☐		○							
1MJ7	225 ... 315				☐	○	○	○	✓		
1PP4	180 ... 315				☐				✓		☐
1PP5	180 ... 200	☐		○						☐	☐
1PP6	100 ... 315				☐				✓		☐
1PP7	63 ... 160	☐		○						☐	☐
1PQ8	315 ... 450				☐	○	○	○			

- ☐ Standard version
- Without additional charge
- ✓ With additional charge



# IEC Squirrel-Cage Motors

## Introduction motors 1LA, 1LG, 1LL, 1LP, 1MA, 1MJ, 1PP, 1PQ

### General technical data

#### Examples of rating plates

See the catalog part "Non-standard motors" for rating plates for motor series 1LA8, 1PQ8 and 1LL8.

Factory number		Temperature class	
Weight	Order No.		
<b>SIEMENS</b> 3-Mot. 1LA7166-2AA60 (EFF2) (H)			
D-91056 Erlangen E0107/471101 01 001 IEC/EN 60034			
93kg IM B3 160L IP55 Th.Cl. 155 (F) CE			
50 Hz 400/690 VΔ/Y		60 Hz 460 VΔ	
18.5 kW 32.5/18.8 A		21.3 kW 32.0 A	
cos φ 0.91 2940/min		cos φ 0.92 3540/min	
380-420/660-725 VΔ/Y		440-480 VΔ	
34.0-32.0/19.6-18.5 A		33.5-31.0 A	
50 Hz data		60 Hz data	
Date of manufacture YY MM		Degree of protection	

<b>SIEMENS</b> 3-Mot. 1LA9166-2KA60 (EFF1) (H)			
D-91056 Erlangen E0107/471101 01 002 IEC/EN 60034			
120 kg IM B3 160L IP55 Th.Cl. 155 (F) AMB 40°C CE			
50 Hz 400/690 VΔ/Y		60 Hz 460 VΔ	
18.5 kW 31.5/18.2 A		18.5 kW 27.7 A	
cos φ 0.92 2940/min		PF 0.92 3550RPM	
380-420/660-725 VΔ/Y		NEMA NOM.EFF 91.0% 25.0HP	
34.0-30.5/19.6-17.6 A		DESIGN A CODE J CC 032 A	
		MG1-12 SF1.15 CONT	

<b>SIEMENS</b> 3-Mot. 1LG6 186-4AA60-Z (EFF1) (H)			
D-91056 Erlangen UC 0202 /012415501			
180 kg IM B3 180L IP55 Th.Cl. 155 (F) AMB 40 °C			
50 Hz 400/690 VΔ/Y		60 Hz 460 VΔ	
22 kW 40.5/24 A		22 kW 36.5 A	
cos φ 0.84 1470/min		PF 0.83 1775RPM	
380-420/660-725 VΔ/Y		NEMA NOM.EFF 92.4% 30.0HP	
42.5-40.5/24.5-23.5 A		DESIGN A CODE K CC 032 A	
IEC/EN 60034		MG1-12 SF1.15 CONT	

<b>SIEMENS</b> 3-Mot. 1MJ6166-2CA60-Z (H)			
D-91056 Erlangen E0107/471101 13 003 IEC/EN 60034			
160 kg IM B3 160L IP55 Th.Cl. 155 (F) CE 0158			
50 Hz 400/690 VΔ/Y		VIK II 2 G	
18.5 kW 32.5/18.8 A		Ex de II C T4	
cos φ 0.91 2940/min		34.0/19.6 A	
380-420/660-725 VΔ/Y		PTB 01 ATEX 1093	
		IA/IN 7.0	

#### Coolant temperature and site altitude

The rated output specified in the selection tables is applicable for continuous duty in accordance with DIN EN 60034-1 at a frequency of 50 Hz, a coolant temperature (CT) or ambient temperature (AT) of 40 °C and a site altitude (SA) or up to 1000 m above sea level.

For higher coolant temperatures and/or site altitudes higher than 1000 m above sea level, the specified motor output must be reduced using the factor  $k_{HT}$ .

Depending on the frame size of the motor or the number of poles, special windings may be added to the motors for the different operating conditions.

This results in an admissible output of the motor of:

$$P_{adm.} = P_{rated} \cdot k_{HT}$$

#### Reduction factor $k_{HT}$ for different site altitudes and/or coolant temperatures

Site altitude above sea level m	Site altitude above sea level Coolant temperature					
	<30 °C	30 °C ... 40 °C	45 °C	50 °C	55 °C	60 °C
1000	1.07	1.00	0.96	0.92	0.87	0.82
1500	1.04	0.97	0.93	0.89	0.84	0.79
2000	1.00	0.94	0.90	0.86	0.82	0.77
2500	0.96	0.90	0.86	0.83	0.78	0.74
3000	0.92	0.86	0.82	0.79	0.75	0.70
3500	0.88	0.82	0.79	0.75	0.71	0.67
4000	0.82	0.77	0.74	0.71	0.67	0.63

Coolant temperature and site altitude are rounded-off to 5 °C or 500 m.

If the admissible motor output is no longer adequate for the drive, it should be checked whether the motor with the next higher rate output fulfills the requirements.

Abbreviation	Description	Units
$P_{adm.}$	Admissible motor output	kW
$P_{rated}$	Rated output	kW
$k_{HT}$	Factor for abnormal coolant temperature and/or site altitude	

The motors are designed for temperature class 155 (F) and used in temperature class 130 (B). Under non-standard operating conditions, if they are to be used in class 130 (B), the admissible output must be determined from the tables below.

If explosion-proof motors are to be used (with the exception of 1MJ6) at coolant temperatures that exceed 40 °C and site altitudes higher than 1000 m above sea level, the appropriate correction factors must be requested.

# IEC Squirrel-Cage Motors

## Introduction motors 1LA, 1LG, 1LL, 1LP, 1MA, 1MJ, 1PP, 1PQ

### General technical data

For the following outputs, rms values are specified for coolant temperatures (CT) of 45 °C and 50 °C that must be specified when ordering.

Power (kW)	Admissible output at 50 Hz	
	For CT 45 °C	For CT 50 °C
kW	kW	kW
<b>11</b>	10.5	10
<b>15</b>	14.5	13.8
<b>18.5</b>	17.8	17
<b>22</b>	21	20
<b>30</b>	29	27.5
<b>37</b>	35.5	34
<b>45</b>	43	41.5
<b>55</b>	53	51
<b>75</b>	72	69
<b>90</b>	86	83
<b>110</b>	106	101
<b>132</b>	127	122
<b>145</b>	139	133
<b>160</b>	153	147
<b>180</b>	173	166
<b>200</b>	192	184
<b>250</b>	240	230
<b>280</b>	269	258
<b>315</b>	302	290
<b>355</b>	340	325
<b>400</b>	384	368
<b>450</b>	432	414
<b>500</b>	480	460
<b>560</b>	538	515
<b>630</b>	605	580
<b>710</b>	682	663
<b>800</b>	768	736
<b>900</b>	864	828
<b>1000</b>	960	920

For details of derating for use in class 155 (F), see "DURIGNIT IR 2000" insulation system.

Motors for coolant temperatures other than 40 °C or site altitudes higher than 1000 m above sea level for use in temperature class 130 (B), must always be ordered with the supplementary order code "**-Z**" and plain text. In the case of extreme derating, the operating data for the motors will be less favourable due to partial utilization.

The following special versions are possible for 1LG4, 1LG6, 1LP4, 1PP4 and 1LA8 motors:

- Motors for coolant temperatures from -50 to +40 °C order code **D02** (not for 1LA8)
- Motors for coolant temperatures from -40 to +40 °C order code **D03**
- Motors for coolant temperatures from -30 to +40 °C order code **D04**

The following special versions are possible for 1LA8, 1PQ8 and 1LL8 motors:

- Motors for 45 °C coolant temperature, 4 % derating, order code **D11**
- Motors for 50 °C coolant temperature, 8 % derating, order code **D12**
- Motors for 55 °C coolant temperature, 13 % derating, order code **D13**
- Motors for 60 °C coolant temperature, 18 % derating, order code **D14**

For details of order codes for use in temperature class 155 (F), see "DURIGNIT IR 2000 insulation system" under "Windings and insulation".

The following applies to all motors:

The motors can withstand 1.5 times the rated current at rated voltage and frequency for two minutes (DIN EN 60034).

Ambient temperature:

All motors can be used in the standard version at ambient temperatures between -20 and +40 °C.

Motors can be used in temperature class 155 (F)

- at 40 °C with service factor 1.1, i.e. the motor can be continuously overloaded with 10 % of the rated output (for motors of 1LG6 and 1LA9 series, with the exception of 1LA9 with increased output, with service factor 1.15, i.e. 15 % of the rated output)
- above 40 °C at rated output.

When motors are used in temperature class 130 (B) for higher ambient temperatures and site altitudes, derating occurs in accordance with the table "Reduction factor  $k_{HT}$  for different site altitudes and/or coolant temperatures".

For motors ex-stock, the service factor is indicated on the rating plate.

For other temperatures, special measures are necessary.

When brakes are to be mounted on motors intended for operation at temperatures below freezing, please contact your local Siemens office.

### Windings and insulation

#### DURIGNIT IR 2000 insulation system

The DURIGNIT IR 2000 insulation system comprises high-grade enameled wires and insulating sheet materials combined with solvent-free impregnating resin.

The system ensures a high level of mechanical and electrical strength as well as good serviceability and a long motor life.

The insulation system protects the winding against aggressive gases, vapors, dust, oil and increased air humidity. It can withstand the usual vibration stressing.

The insulation is suitable up to an absolute air humidity of 30 g water per m<sup>3</sup> of air. Moisture condensation should be prevented from forming on the winding. Please contact your local Siemens office if higher values are present.

Please inquire about extreme applications.

#### Winding and insulation design with regard to temperature class and air humidity

All motors are designed for temperature class 155 (F).

At rated output with mains-fed operation, the motors can be used in temperature class 130 (B).

#### **Temperature class 155 (F), used according to 155 (F), with service factor (SF)**

For all 1LA motors (with the exception of 1LA9 with increased output, as these are already used according to temperature class 155 (F)), 1LG, 1LL8 and 1PP motors for mains-fed operation in frame sizes 56 to 355 for the rated output given in the selection table and rated voltage, a service factor of 1.1 can be specified (for 1LA9 and 1LG6 SF = 1.15) and 1.05 for frame sizes 400 and 450.

Order code **C11**.

#### **Temperature class 155 (F), used according to 155 (F), for increased output**

For motors supplied from stock (with the exception of 1LA9 with increased output, as these are already used according to temperature class 155 (F)) and 1LA8 motors, the service factor is indicated on the rating plate as standard. For use according to temperature class 155 (F), the rated output according to the selection and ordering data can be increased by 10 % (15 % for 1LA9, with the exception of 1LA9 with increased output, and 1LG6) and by 1.05 for frame sizes 400 and 450.

Order code **C12**.

**Temperature class 155 (F), used according to 155 (F), with increased coolant temperature**

At the output specified in the catalog under mains-fed operation, the coolant temperature can be increased to 55 °C (50 °C for frame sizes 400 and 450) with the exception of 1LA9 with increased output.

Order code **C13**

The service factor (SF) is not indicated on the rating plate for order codes C12 and C13.

For converter-fed operation at the output specified in the catalog, the motors are used according to temperature class 155 (F). Order codes C11, C12 and C13 are not possible. This applies to motors up to 500 V and to motors up to 690 V.

**Temperature class 180 (H), used according to 155 (F), with Service Factor (SF1.1)**

For all 1LA8, 1PQ8 and 1LL8 motors for mains-fed operation in frame sizes 315 to 355 for the rated output given in the selection table and rated voltage, a service factor of 1.1 and 1.05 can be specified (for frame sizes 400 and 450). For use according to temperature class 180 (H), as service factor of 1.1 for mains-fed operation is also permissible.

For all 1LA8, 1PQ8 and 1LL8 motors for converter-fed operation in frame sizes 315 to 450 for the rated output given in the selection table and rated voltage, a service factor of 1.1 can be specified. The thermal service life of the motor winding increases by at least 5 times when used in converter-fed operation.

Use according to temperature class 180 (H) is not possible for all motors. All 400 V versions are available only on request. Due to the rated current, a larger connection box of type 1XB9600 is generally provided for frame sizes 400 (2 and 4 pole) and 450 (all pole numbers) – part of order code C14. The temperature class 180 (H) does not apply to motors with separately driven fan with 1PQ8.

Order code **C14**

**Temperature class 155 (F), used according to 130 (B), with increased coolant temperature and/or site altitude**

For standard motors, explosion-proof motors and fan motors 1LA5, 1LA6, 1LA7, 1LA9 (with the exception of 1LA9 with increased output since these are already used according to temperature class 155 (F)), 1LG4, 1LG6, 1LP4, 1MJ6, 1MJ7, 1PP4, 1PP5, and 1PP7, a version designed for temperature class 155 (F) for use according to temperature class 130 (B) can be ordered with other customized requirements with specification in plain text.

Order code **Y50**

**Temperature class 155 (F), used according to 155 (F), other requirements**

For 1LA5, 1LA6, 1LA7, 1LA9, 1LG4, 1LG6, 1PP4, 1PP5 and 1PP7 standard motors and fan motors as well as 1MA6 and 1MA7 explosion-proof motors, a version can be ordered designed for temperature class 155 (F), for use according to temperature class 155 (F) with different customized requirements, by specifying the information in plain text. Certification costs may be charged in the case of 1MA6 and 1MA7 motors.

Order code **Y52**

**Temperature class 180 (H) at rated output and maximum coolant temperature (CT) 60 °C**

For motor series 1LA5, 1LA6, 1LA7, 1LG4, 1PP4, 1PP5 and 1PP7, use according to temperature class 180 (H) is permitted at rated output and at a maximum coolant temperature of 60 °C. This does not apply to explosion-proof motors of Zones 2, 21 and 22 and to motors with UL approval (order code **D31**). Not possible for CSA approval (order code **D40**) for 1LA5, 1LG4, 1PP4 and 1PP5 motor series. The specified grease life applies to a coolant temperature of 40 °C. For a 10 K increase in coolant temperature, the grease life or lubrication interval is halved.

Order code **C18**

**Temperature class 155 (F), used according to 130 (B), coolant temperature 45 °C, approx. 4 % derating**

For motors of series 1LA5, 1LA6, 1LA7, 1LA9 (with the exception of 1LA9 with increased output), 1LG4, 1LG6, 1MA6, 1MA7, 1MJ6, 1MJ7, 1PP4, 1PP5, and 1PP7, a version can be ordered that is designed to temperature class 155 (F), for use according to temperature class 130 (B) at a maximum coolant temperature of 45 °C at 4 % derating.

Order code **C22**

**Temperature class 155 (F), used according to 130 (B), coolant temperature 50 °C, approx. 8 % derating**

For motors of series 1LA5, 1LA6, 1LA7, 1LA9 (with the exception of 1LA9 with increased output), 1LG4, 1LG6, 1MA6, 1MA7, 1MJ6, 1MJ7, 1PP4, 1PP5, and 1PP7, a version can be ordered that is designed to temperature class 155 (F), for use according to temperature class 130 (B) at a maximum coolant temperature of 50 °C at 8 % derating.

Order code **C23**

**Temperature class 155 (F), used according to 130 (B), coolant temperature 55 °C, approx. 13 % derating**

For motors of series 1LA5, 1LA6, 1LA7, 1LA9 (with the exception of 1LA9 with increased output), 1LG4, 1LG6, 1MA6, 1MA7, 1MJ6, 1MJ7, 1PP4, 1PP5, and 1PP7, a version can be ordered that is designed to temperature class 155 (F), for use according to temperature class 130 (B) at a maximum coolant temperature of 55 °C at 13 % derating.

Order code **C24**

**Temperature class 155 (F), used according to 130 (B), coolant temperature 60 °C, approx. 18 % derating**

For motors of series 1LA5, 1LA6, 1LA7, 1LA9 (with the exception of 1LA9 with increased output), 1LG4, 1LG6, 1MA6, 1MA7, 1MJ6, 1MJ7, 1PP4, 1PP5, and 1PP7, a version can be ordered designed for temperature class 155 (F), for use according to temperature class 130 (B) at a maximum coolant temperature of 60 °C at 18 % derating.

Order code **C25**

**Increased air temperature/humidity with 30 to 60 g water per m<sup>3</sup> of air**

For motors of series 1LA5, 1LA6, 1LA7, 1LA9, 1LG4, 1LG6, 1LP4, 1LP5, 1LP7, 1MA6, 1MA7, 1MJ6, 1MJ7, 1PP4, 1PP5 and 1PP7, a version can be ordered for increased air humidity of between 30 and 60 g water per m<sup>3</sup> of air depending on the temperature as listed in the table below. This version includes condensation drainage holes (order code L12) – with the exception of 1MJ motors. A condensation protection by means of anti-condensation heaters for 230 V (order code K45) is included in 1MJ6 and 1MJ7 motors.

Order code **C19**.

Please contact your local Siemens office if order code **C19** is to be combined with additional mountings.

**Increased air temperature/humidity with more than 60 g up to 100 g water per m<sup>3</sup> of air**

For motors of series 1LA5, 1LA6, 1LA7, 1LA9, 1LG4, 1LG6, 1LP4, 1LP5, 1LP7, 1MA6, 1MA7, 1MJ6, 1MJ7, 1PP4, 1PP5 and 1PP7, a version can be ordered for increased air humidity of between more than 60 g and 100 g water per m<sup>3</sup> of air depending on the temperature as listed in the table below. This version includes condensation drainage holes (order code L12) – with the exception of 1MJ motors. A condensation protection by means of anti-condensation heaters for 230 V (order code K45) is included in 1MJ6 and 1MJ7 motors.

Order code **C26**.

Please contact your local Siemens office if order code **C26** is to be combined with additional mountings (e.g. rotary pulse encoders, brakes).

# IEC Squirrel-Cage Motors

## Introduction motors 1LA, 1LG, 1LL, 1LP, 1MA, 1MJ, 1PP, 1PQ

### General technical data

#### Absolute/relative conversion of air humidity

Relative humidity	Temperature							
	20 °C	30 °C	40 °C	50 °C	60 °C	70 °C	80 °C	90 °C
10 %	2	3	5	8	13	20	29	42
15 %	3	5	8	12	19	30	44	63
20 %	3	6	10	17	26	39	58	84
25 %	4	8	13	21	32	49	73	105
30 %	5	9	15	25	39	59	87	126
35 %	6	11	18	29	45	69	102	146
40 %	7	12	20	33	52	79	116	167
45 %	8	14	23	37	58	89	131	188
50 %	9	15	26	41	65	98	145	209
55 %	10	17	28	46	71	108	160	230
60 %	10	19	31	50	78	118	174	251
65 %	11	20	33	54	84	128	189	272
70 %	12	21	36	58	91	138	203	293
75 %	13	23	38	62	97	148	218	314
80 %	14	24	41	66	104	157	233	335
85 %	15	26	43	70	110	167	247	356
90 %	16	27	46	74	117	177	262	377
95 %	16	29	49	79	123	187	276	398
100 %	17	30	51	83	130	197	291	419

The values in the table with a blue background are covered by the standard version (up to 30 g water per m<sup>3</sup> of air).

The values in the table with a light gray background are covered by order code **C19** (30 to 60 g of water per m<sup>3</sup> of air).

The values in the table with a dark gray background are covered by order code **C26** (60 to 100 g of water per m<sup>3</sup> of air).

Please contact your local Siemens office regarding requirements exceeding 100 g water per m<sup>3</sup> of air

#### Restarting against residual field and opposite phase

All motors can be reclosed against 100 % residual field after a mains voltage failure.

#### Motor protection

A distinction is made between current-dependent and motor-temperature-dependent protection devices.

##### Current-dependent protection devices

**Fuses** are only used to protect mains cables in the event of a short-circuit. They are not suitable for overload protection of the motor.

The motors are usually protected by delayed overload protection devices (circuit-breakers for motor protection or overload relays).

This protection is current-dependent and is particularly effective in the case of a locked rotor.

For standard duty with short start-up times and starting currents that are not excessive and for low numbers of switching operations, motor protection switches provide adequate protection. Motor protection switches are not suitable for high starting duty or large numbers of switching operations. Differences in the thermal time constants for the protection equipment and the motor results in unnecessary early tripping when the protection switch is set to rated current.

##### Motor-temperature-dependent protection devices

**Temperature detectors** installed in the motor winding are suitable protection devices in the case of slowly rising motor temperature.

When a limit temperature is reached, these **bimetal switches** (NC contacts) can deactivate an auxiliary circuit. The circuit can only be reclosed following a considerable fall in temperature. When the motor current rises quickly (e.g. with a locked rotor), these switches are not suitable due to their large thermal time constants.

Temperature detectors for tripping

Order code **A31**

The temperature monitors have the following current carrying capacity and switching capacity:

230 V AC cosφ: 2.5 A

24 V DC: 1.6 A

The most comprehensive protection against thermal overloading of the motor is provided by **PTC thermistors (thermistor motor protection)** installed in the motor winding. Due to its low heating capacity and excellent thermal contact with the winding, the winding temperature can be closely monitored. When a limit temperature is reached (nominal tripping temperature), the PTC thermistor undergoes a step change in resistance. This is evaluated by a tripping unit and can be used to open auxiliary circuits. The PTC thermistors themselves cannot be subjected to high currents and voltages. This would result in destruction of the semiconductor. The switching hysteresis of the PTC thermistor and tripping unit is low, which supports fast restarting of the drive. Motors with this type of protection are recommended for high duty starting, switching duty, extreme changes in load, high ambient temperatures or fluctuating supply systems.

Motor protection with PTC thermistors with 3 embedded temperature sensors for tripping.

In the connection box, 2 auxiliary terminals are required. The maximum number of auxiliary terminals in the main connection box of the motor is specified under "Number of auxiliary terminals" in the section "Motor connection and connection box". An auxiliary connection box is required when the total number of auxiliary terminals in the connection box of the motor exceeds the specified values. For an additional charge, the connections can be routed through a separate auxiliary connection box (order code L97, M50 or M88, see "Auxiliary connection box" in the section "Motor connection and connection box").

Order code **A11**

For pole-changing motors with two separate windings, the number of temperature sensors must be doubled.

Two sets of three temperature sensors are used if a warning is required before the motor is shut down (tripped). The warning is normally set to 10 K below the tripping temperature.

Motor protection with PTC thermistors with 6 embedded temperature sensors for tripping and alarm.

In the connection box, 4 auxiliary terminals are required.

Order code **A12**

- All 1LA8 motors are equipped in the standard version with 6 PTC thermistors for alarm and tripping.
- For 1LA, 1MJ and 1LG motors, the tripping temperature corresponds to PTC thermistors for temperature class 155 (F).
- For 1LA8, 1LL and 1PQ motors, the tripping temperature corresponds to PTC thermistors for temperature class 155 (F), also for 1LA8 in Zone 22.
- For 1LA and 1LG motors for Zones 2, 21, 22 or VIK thermistors temperature class 130 (B) (see catalog part "Motors operating with frequency converters").

In order to achieve full thermal protection it is necessary to combine a thermally delayed overcurrent release and a PTC thermistor. For full motor protection implemented only with PTC thermistors, please inquire.

#### Motor temperature detection with converter-fed operation

##### KTY 84-130 temperature sensor

This sensor is a semi-conductor that changes its resistance depending on temperature in accordance with a defined curve.

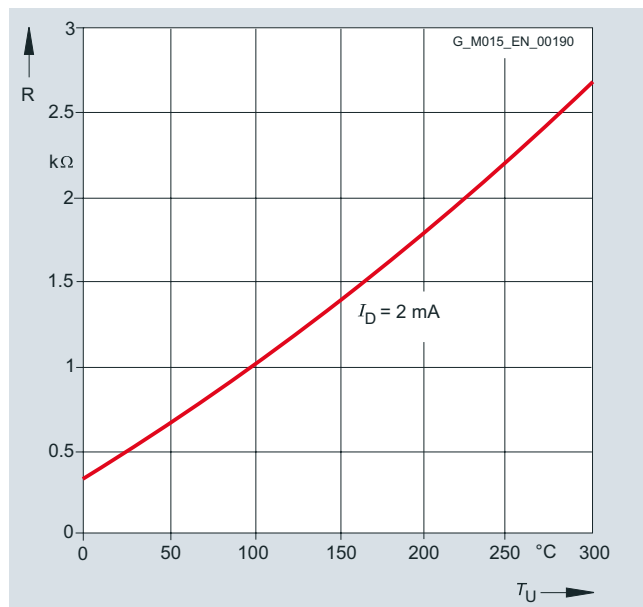

KTY 84-130 temperature sensor characteristic

Some converters from Siemens determine the motor temperature using the resistance of the temperature sensor. They can be set to a required temperature for alarm and tripping.

Motor temperature detection with embedded temperature sensor KTY 84-130.

In the connection box, 2 auxiliary terminals are required.

The maximum number of auxiliary terminals in the main connection box of the motor is specified under "Number of auxiliary terminals" in the section "Motor connection and connection box".

An auxiliary connection box is required when the total number of auxiliary terminals in the connection box of the motor exceeds the specified values. For an additional charge, the connections can be routed through a separate auxiliary connection box (order code L97, M50 or M88, see "Auxiliary connection box" in the section "Motor connection and connection box").

Order code **A23**

For 1LA8 motors, the standard PTC thermistors are omitted when ordering with order code **A23**. A combination of A12 and A23 is possible, price on request.

OR

Motor temperature detection with embedded temperature sensors 2 x KTY 84-130.

In the connection box, 4 auxiliary terminals are required.

Order code **A25**

The temperature sensor is embedded in the winding head of the motor in the same manner as a PTC thermistor. Evaluation is performed, for example, in the converter.

For mains-fed operation, the temperature monitoring device 3RS10 that is part of the protection equipment can be ordered separately. For further details, see Catalog LV 1, Order No.: E86060-K1002-A101-A7-7600.

#### Motor protection

1LA and 1LG motors for Zones 2, 21 and 22 for converter-fed operation already have a PTC thermistor for tripping as standard. For converter-fed operation, a PTC thermistor for alarm can be ordered additionally.

PTC thermistor for alarm for converter-fed operation in Zones 2, 21 and 22.

In the connection box, 2 auxiliary terminals are required.

Order code **A10**

1MJ motors:

PTC thermistors must always be used if the duty is not S1 (continuous operation) in accordance with IEC 60034-1/DIN EN 60034-1.

If 1MJ motors are operated with converters, the PTC thermistor in the winding is essential. For 1MJ6/1MJ7 motors, an additional PTC thermistor is installed in the connection box.

Motor protection with PTC thermistors for converter-fed operation with 3 or 4 embedded temperature sensors for tripping.

In the connection box, 2 auxiliary terminals are required.

Order code **A15**.

or

Motor protection with PTC thermistors for converter-fed operation with 6 or 8 embedded temperature sensors for alarm and tripping.

In the connection box, 4 auxiliary terminals are required.

Order code **A16**.

For versions with temperature sensors, in some cases, anti-condensation heaters cannot be mounted or can only be mounted for certain frame sizes. See "Special versions" in the corresponding catalog parts.

If thermistor protection is required, 3 PTC thermistors connected in series are embedded in the stator winding of the motor.

The 3RN1 temperature monitoring device that is part of the protection equipment must be ordered separately – it is PTB certified. For further details about mode of operation, circuit and prices, see Catalog LV 1,

Order No.: E86060-K1002-A101-A7-7600.

# IEC Squirrel-Cage Motors

## Introduction motors 1LA, 1LG, 1LL, 1LP, 1MA, 1MJ, 1PP, 1PQ

### General technical data

#### Motor temperature detection with resistance thermometers

The resistance thermometers are embedded in the stator winding or in the rolling contact bearings or bearing plates of the motors. The following possibilities can be implemented:

##### Stator winding:

3 or 6 PT 100 resistance thermometers are embedded in the stator winding in 2-wire connection. The two connections for each resistance thermometer are routed through the main connection box. In the connection box, 6 or 12 auxiliary terminals are required. The maximum number of auxiliary terminals in the main connection box of the motor is specified under "Number of auxiliary terminals" in the section "Motor connection and connection box". An auxiliary connection box is required when the total number of auxiliary terminals in the connection box of the motor exceeds the specified values.

For an additional charge, the connections can be routed through a separate auxiliary connection box (order code L97, M50 or M88, see "Auxiliary connection box" in the section "Motor connection and connection box"); 3-wire or 4-wire connection (from the terminal strip) is also possible (please inquire).

The resistance thermometer embedded in the winding head is calibrated to 100 Ω at 0 °C. The base values for the resistances (i.e. the relationship between the resistance and temperature) as well as the admissible deviations are laid down in DIN IEC 751. The changes in temperature are transferred to a display device in the form of changes in resistance.

The display devices are not included in the price and are not included in the delivery package.

Installation of 3 PT 100 resistance thermometers in stator winding.

In the connection box, 6 auxiliary terminals are required.

Order code **A60**

Installation of 6 PT100 resistance thermometers in stator winding.

In the connection box, 12 auxiliary terminals are required.

Order code **A61**

Note regarding non-standard 1LA8 motors: When A61 is ordered, the PTC thermistors installed as standard in the motor are omitted. A combination of A12 and A61 is possible, price on request.

##### Rolling contact bearings or bearing plates:

The bearing thermometers are screwed into the bearing plates of the drive end (DE) and non-drive-end (NDE). The wires are routed through the main connection box.

In the connection box, auxiliary terminals are required. The maximum number of auxiliary terminals in the main connection box of the motor is specified under "Number of auxiliary terminals" in the section "Motor connection and connection box". An auxiliary connection box is required when the total number of auxiliary terminals in the connection box of the motor exceeds the specified values.

For an additional charge, the connections can be routed through a separate auxiliary terminal box (order code L97, M50 or M88, see "Auxiliary connection box" in the section "Motor connection and connection box"). The changes in temperature are transferred to a display device in the form of changes in resistance. The display device is not included in the price and is not included in the delivery package.

Installation of 2 PT 100 screw-in resistance thermometers (basic circuit) for rolling-contact bearings.

In the connection box, 4 auxiliary terminals are required.

Order code **A72**

Installation of 2 PT 100 screw-in resistance thermometers (3-wire circuit) for rolling-contact bearings.

In the connection box, 6 auxiliary terminals are required.

Order code **A78**

Installation of 2 PT 100 double screw-in resistance thermometers (3-wire circuit) for rolling-contact bearings.

In the connection box, 12 auxiliary terminals are required.

Order code **A80**

#### Heating and ventilation

##### Anti-condensation heaters

Supply voltage 230 V (1~)

Order code **K45**

or

Order code **M15**

Supply voltage 115 V (1~)

Order code **K46**

or

Order code **M14**

Motors whose windings are at risk of condensation due to the climatic conditions, e.g. inactive motors in humid atmospheres or motors that are subjected to widely fluctuating temperatures can be equipped with anti-condensation heaters.

An additional cable entry M16 x 1.5 or M20 x 1.5 (M20 x 1.5 or M25 x 1.5 for 1LA8, 1PQ8 and 1LL8 motor series) is provided for the connecting cable.

Anti-condensation heaters must not be switched on during operation.

1MJ6 motors:

For 1MJ6 motors up to frame size 160 L, a built-in anti-condensation heater is not possible for versions with PTC thermistors.

For 1MA and 1LA motors. In designs for Zone 21:

Built-in anti-condensation heaters are not possible up to frame size 200L.

For 1LA8 and 1PQ8 motor series in designs for Zone 2, the anti-condensation heater can only be switched on after the motor has been switched off for one hour.

Instead of an anti-condensation heater, another possibility (without additional charge) is connection of a voltage that is approximately 4 to 10 % of the rated motor voltage to stator terminals U1 and V1; 20 to 30 % of rated motor current is sufficient to heat the motor (this does not apply to 1MA6 frame sizes 225 M to 315 L, 1LA8, 1PQ8 and 1LL8).

Motor series	Frame size	Heater output of the anti-condensation heaters in Watt (W)	
		Supply voltage at	
		230 V	115 V
		Order code	Order code
		<b>K45</b>	<b>K46</b>
<b>1LA5, 1LP5, 1PP5, 1LA6, 1LA7, 1LP7, 1PP7, 1LA9, 1MJ6</b>	56 ... 80	25	25
	90 ... 112	50	50
	132 ... 200	100	100
	225	100	100
<b>1LG4, 1LP4, 1PP4, 1LG6, 1MA6, 1MJ7</b>	180 ... 200	55	55
	225 ... 250	92	92
<b>1LG4, 1LG6 in designs for Zone 2</b>	180 ... 200	48	48
	225 ... 250	92	92
	280 ... 315	105	105
<b>1MA6</b>	280 ... 315	105	105
<b>1LG4, 1LP4, 1PP4, 1LG6, 1MJ7</b>	280 ... 315	109	109
<b>1LA8, 1PQ8, 1LL8</b>	315 ... 450	200	183

Fans/Separately driven fans

Motors of frame sizes 63 to 450 have radial-flow fans in the standard version that cool regardless of the direction of rotation of the motor (cooling method IC 411 acc. to DIN EN 60034-6, IC01 for 1LL8 motor series). The air flow is forced from the non-drive-end (NDE) to the drive end (DE).

Motors of frame size 56 do not have a fan (IC 410).

For details of separately driven fans for frame sizes 100 to 315, see also Page 0/76.

1LA8 and 1LL8 (frame size 355 and above) 2-pole motors have an axial-flow fan for clockwise rotation in the standard version. The fan can be subsequently reinstalled for counter-clockwise rotation.

Motors of the 1LA8 series are also available in a version with a separately driven fan (cooling method IC 416 – 1PQ8 series) and in a version with through-ventilation (cooling method IC 01, IP23 degree of protection – 1LL8 series).

1PQ8 motors have separately driven fans that cool regardless of the speed of the main motor (IC416).

Supply voltages for 1PQ8 separately driven fans:  
230 VΔ/400 VY ±10 %, 50 Hz, 460 VΔ ±10 %, 60 Hz.

Other voltages/frequencies can be ordered by specifying in plain text with order code **Y81** (additional charge).

Supply voltage of separately driven fan for 1LG motors:

The supply voltage of the separately driven fan conforms to the stated rated voltage ranges of table "Technical data of the separately driven fan", see Page 0/76. Deviating voltages/frequencies can be ordered with order code Y81 and plain text (additional charge).

When the motor is mounted and the air intake is restricted, then it must be ensured that a minimum clearance is maintained between the fan cover and the wall. This clearance is calculated from the difference between the protective cover and the fan cover (dimension LM – L) or is specified in the detail dimension drawing.

For design of the fan/separately driven fan and the fan cover, see the tables below.

Metal external fan impeller

The standard fan impeller made of plastic can be replaced with a fan impeller made of metal. This version can be supplied for motor series 1LA5, 1LA6, 1LA7, 1LA8, 1LA9, 1LG4, 1LG6, 1MA6, 1MA7, 1MJ6, 1MJ7 and 1LL8.

For motor series 1LA5, 1LA6, 1LA7, 1LA9, 1LG4 and 1LG6, the metal external fan can also be used with converter-fed operation.

A metal external fan is already included for the low-noise version.

Up to frame size 160, the metal external fan impeller is manufactured from sheet aluminum or steel and for frame size 180 and above it is manufactured from cast iron or sheet steel.

Order codes **K35**

Fan cover for textile industry

For motors 1LG4 and 1LG6, the fan cover can be used in the standard version for the textile industry.

For motor series 1LA5, 1LA6, 1LA7 and 1LA9, a version of the fan cover can be supplied specially for the textile industry. This has a protective cover and is made of non-corrosive sheet steel.

Order code **H17**

Cast-iron fan cover

For 1MA6 motor series, frame sizes 225 to 315, the fan cover can be supplied in cast-iron instead of plastic.

Order code **K34**

Sheet metal fan cover

For 1LG4 and 1LG6 motor series, the fan cover can be supplied in sheet metal instead of plastic.

Order code **L36**

For 1LA8, 1PQ8 and 1LL8 motor series, the sheet-metal fan cover is supplied as standard.

Design of fan and fan cover for standard motors, explosion-proof motors, motors operating with frequency converters, fan motors and smoke extraction motors:

Motor series	Frame size	Fan material <sup>1)</sup>	Fan cover material <sup>1)</sup>
<b>1LA5, 1LA7</b>	63 ... 225	Plastic	Non-corrosive sheet steel
<b>1LA9</b>	63 ... 200		
<b>1LA6</b>	100 ... 160		
<b>1MA7</b>	63 ... 160		
<b>1MA6</b>	100 ... 315		
<b>1MJ6</b>	71 ... 200		
<b>1MJ7</b>	255 ... 315		
<b>1LG4, 1LG6</b>	180 ... 315	Plastic	Glass fiber strengthened plastic <sup>2)</sup>

Design of the fan/separately driven fan and the fan cover for non-standard motors

Motor series	Frame size	Fan material <sup>3)</sup>	Fan cover material
<b>1LA8, 1LL8</b>	315	Radial-flow fan, plastic	Non-corrosive sheet steel
<b>1PQ8</b>		Radial-flow fan, sheet steel	
<b>1LA8, 1LL8</b>	355 ... 400	Axial-flow fan, cast aluminum	Radial-flow fan, plastic
<b>1PQ8</b>		Radial-flow fan, sheet steel	Radial-flow fan, sheet steel
<b>1LA8, 1LL8</b>	450	Axial-flow fan, hub: cast aluminum, vane: plastic	Radial-flow fan, plastic
<b>1PQ8</b>		Radial-flow fan, sheet steel	Radial-flow fan, sheet steel

<sup>1)</sup> The plastic fan can be used at ambient temperatures of up to 70 °C. For designs for Zones 21 and 22 and VIK, other materials are used in some cases.

<sup>2)</sup> For designs:  
for Zones 2, 21 and 22 VIK (order code **K30**),  
CSA (order code **D40**)  
UL (order code **D31**)  
a fan cover is used that is made of non-corrosive sheet steel.

<sup>3)</sup> The plastic fan can be used at ambient temperatures of up to 70 °C. For designs for Zones 21 and 22, VIK and UL, other materials are used in some cases.

# IEC Squirrel-Cage Motors

## Introduction motors 1LA, 1LG, 1LL, 1LP, 1MA, 1MJ, 1PP, 1PQ

### General technical data

0

#### Motor connection and connection box

##### Connection, circuit and connection box

##### Location of the connection box

The connection box of the motor can be mounted in four different locations or positions. The position of the connection box must always be viewed from the drive end (DE). The standard position of the connection box is on top, with the exception of non-standard motors in which case the standard position of the connection box is on the right-hand side.

Connection box on right-hand side – Order code **K09**

Connection box on left-hand side – Order code **K10**

If rotation of the connection box is possible later for motors that are supplied as standard with cast feet, the version "Connection box on top, feet screwed on" is recommended.

Order code **K11**

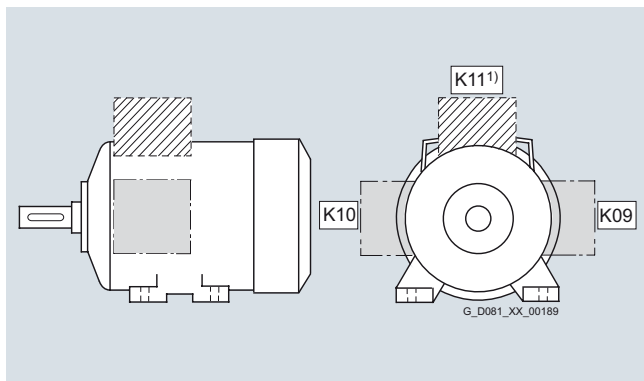

The number of winding ends depends on the winding design. Three-phase motors are connected to the three phase conductors L1, L2 and L3 of a three-phase system. The rated voltage of the motor in the running connection must match the phase conductor voltages of the network.

When the three phases are operating in a time sequence and are connected to the terminals of the motor in alphabetical order U1, V1 and W1, clockwise rotation is established as viewed from the motor shaft. The direction of rotation of the motor can be reversed if two connecting leads are interchanged.

Labeled terminals are provided to connect the protective conductor.

A protective earth terminal is provided in the connection box for earthing. An earth terminal is located on the outside of the motor housing (special version in the case of 1LA5, 1LA6, 1LA7 and 1LA9 motors. Order code **L13**).

If a brake control system or thermal protection is installed, the connections will also be in the connection box.

The motors are suitable for direct connection to the line supply.

##### Design of the connection box

**Connection boxes for motors to Exn (Zone 2) type of protection and for protection against dust explosions (Zone 21) differ from the basic version. For dust explosion protection (Zone 22), the connection boxes of the basic version are used.**

For 1LG4 and 1LG6 motors, frame sizes 180 to 225 and 1MA6 motors frame sizes 180 to 200, 1MJ6 frame sizes 71 to 160 M and frame sizes 180 to 200 L, a connection box is available in cast iron.

Order code **K15**

For 1LA6 and 1MA6 frame size 100 – 160, 1MJ6 frame size 160 L and 1MJ7, 1MA6 frame size 225 – 315 standard version. Not possible for 1LA7 and 1MA7.

For 1MJ motors:

The connection boxes are designed to Ex e type of protection. The ends of the windings for motors up to frame size 160 are routed through a shared explosion-proof leadthrough into the connection box; for frame size 180 and above, they are routed through single leadthroughs.

For 1MJ motors, an explosion-proof connection box with Ex d II C type of protection is available.

Order code **K53**

For motor series 1LA8, 1PQ8 and 1LL8, the ends of the windings are routed through single leadthroughs into the connection box.

The number of terminals and the size of the connection box is designed for standard requirements. For special requirements or if the customer requires a larger connection box, the connection box for the next larger frame size can be supplied.

For all motors except for non-standard motors and 1MJ motors:

Next larger connection box (only frame size 180 and above)

Order code **L00**

Detailed assignment of connection boxes, see Page 0/43 and 0/46.

For non-standard motors (motor series 1LA8, 1PQ8 and 1LL8)

Next larger 1XB1 621 connection box

Order code **M58**

Next larger 1XB1 631 connection box

Order code **L00**

Detailed assignment of connection boxes, see Page 0/43 and 0/44.

If the necessary installation angle of the motor would cause machine components to collide with the connection box, the connection box can be moved from the drive end (DE) to the non-drive end (NDE).

Order code **M64**

Not possible for explosion-proof motors.

#### Motor connection

##### Line feeder cables

The line feeder cables must be dimensioned acc. to DIN VDE 0298. The number of required feeder cables, if necessary in parallel, is defined by:

- The max. cable cross-section which can be connected
- The cable type
- Routing
- Ambient temperature and the corresponding admissible current in accordance with DIN VDE 0298

##### Parallel feeders

Some motors must be fitted with parallel feeders due to the admissible current per terminal. These motors are indicated in the selection and ordering data in the respective catalog parts. With 1XB7 connection boxes, 2 parallel feeders are possible; with 1XB1 631 connection boxes, up to 4 parallel feeders are possible; and with GT640 and 1XB1 621 connection boxes, 2 parallel feeders are possible.

For motors with an upper connection box section and auxiliary terminals (e.g. with order code **A11**), an M16 x 1.5 or M20 x 1.5 cable gland with plug is additionally available.

For further details, see the data sheet function in SD configurator.

<sup>1)</sup> Possible for frame size IM B3, IM B6, IM B7, IM B8, IM V6 with/without protective cover, IM B35.



1LA7 and 1LA9 in frame size 100 L to 160 L

The connection box is integrated into the frame. Two knock-outs are provided at each side for boltings. The nuts for the boltings are supplied with the connection box.

#### Cable entry on connection box

Unless stated otherwise, the cable entry is located in the standard position as shown in the illustration below.

The connection box can also be rotated such that the cable entry is located

- Towards the drive end (DE)  
(rotation of connection box by 90°, entry from DE)  
Order code **K83**
- Towards the non-drive end (NDE)  
(rotation of connection box by 90°, entry from NDE)  
Order code **K84**

With options **K83** and **K84**, 1LA7 motors of frame sizes 100 to 160 require an additional connection box upper section. This measure results in increased height of the connection box. The dimension AD increases by approx. 30 mm, dimension AF changes depending on the frame size by between 45 and 47 mm. For the precise values of AD and AF, see "Dimension drawings" in the corresponding catalog parts.

If the cable entry is rotated by 180°, special measures are required for 1LA7 and 1LA5 motors of frame sizes 63 to 90 as well as 180 to 225 (without a change in dimensions). (Rotation of the connection box by 180°)  
Order code **K85**

From frame size 100 to 160, the break-outs in the connection box can be used.

The dimensions of the connection box are listed in the relevant catalog parts in accordance with the frame size and the "Dimension drawings".

If the position of the connection box (connection box RHS, LHS or above) is changed, the position of the cable entry must be checked and, if necessary, it can be ordered with the corresponding order codes (**K83**; **K84**; **K85**).

#### Ordering example

Connection box RHS (Order code **K09**):

If no other order code is specified, cable entry is from below.

With additional order code **K83**:

Cable entry from drive end (DE)

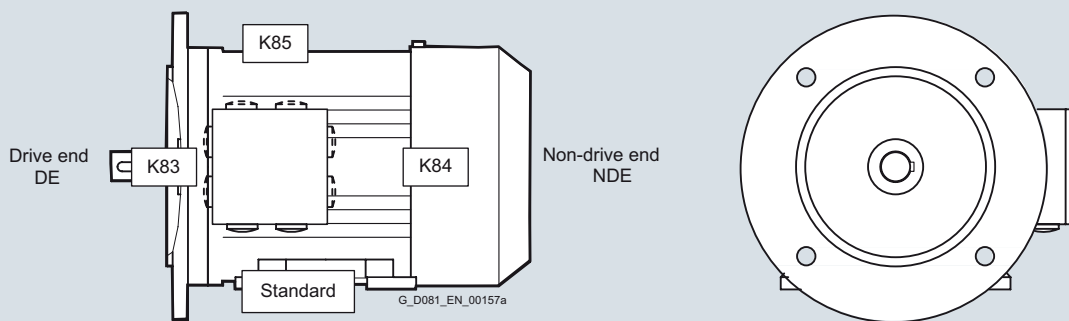

For cable entry to a standard connection box, a **cable gland** can be ordered for motor connection.

One cable gland, metal

Order code **K54**

For cable entry to a connection box with the options of motor protection or anti-condensation heating, **two cable glands** will be supplied.

Cable glands are supplied in metal as standard. For temperatures below -30 °C and/or higher than +60 °C, the material is selected/used according to the temperature.

Cable gland, maximum configuration

Order code **K55**

For non-standard motors (motor series 1LA8, 1PQ8 and 1LL8), the cable entry can be implemented in accordance with DIN 89280 for the maximum possible configuration of cable glands in the connection box.

Order code **K57**

A two-part plate on the connection box can be supplied if required.

Order code **K06**

# IEC Squirrel-Cage Motors

## Introduction motors 1LA, 1LG, 1LL, 1LP, 1MA, 1MJ, 1PP, 1PQ

### General technical data

0

For special requirements for which the standard holes for the cable entries are inadequate, too large or when the routing must be implemented differently, an undrilled entry plate can be supplied to allow holes to be drilled as required on assembly.  
Order code **L01**

#### Protruding cable ends

For confined spaces, protruding cable ends can be ordered, without a connection box with cover plate.

For protruding cable ends for smoke extraction motors, see catalog part 9 "Smoke extraction motors".

The following lengths of protruding cables can already be ordered using order codes on request:

- 3 cables protruding, 0.5 m long <sup>1)</sup>  
Order code **L44**
- 3 cables protruding, 1.5 m long <sup>1)</sup>  
Order code **L45**
- 6 cables protruding, 0.5 m long  
Order code **L47**
- 6 cables protruding, 1.5 m long  
Order code **L48**
- 6 cables protruding, 3.0 m long  
Order code **L49**

The cross-section of the named cables refers to a coolant temperature up to CT 40 °C

It is also possible to rotate the position of the three protruding cables:

- Cable connection on right side, as viewed from drive end (DE) <sup>2)</sup>  
Order code **L51**
- Cable connection on left side, as viewed from non-drive end (NDE) <sup>2)</sup>  
Order code **L52**

For 1LG4/1LG6/1LP4/1PP4 motors, it is also possible to order the length of protruding cable in plain text with order codes **L51** and **L52**.

In combination with winding monitoring (order code **A11, A12, A15, A16, A23, A25 or A31**) or anti-condensation heating (order code **K45 or K46**), option **L44, L45, L47, L48 or L49** must be specified twice on ordering.

#### Position of protruding cables

##### Motor series 1LA7

Frame sizes 56 to 160:

As standard, above at drive end (DE).

##### Motor series 1LA6

Frame sizes 100 to 160:

As standard, above at drive end (DE).

##### Motor series 1LA5

Frame sizes 180 to 225:

As standard, above at drive end (DE).

##### Motor series 1LA9

Frame sizes 56 to 200:

As standard, above at drive end (DE).

##### Motor series 1LG4/1LG6/1LP4/1PP4

Frame sizes 180 to 315:

As standard, above at drive end (DE).

Optionally left or right at drive end (DE)

<sup>1)</sup> With only 3 protruding cables additional plain text specifying star or delta connection is required.

<sup>2)</sup> For motor series 1LA5, 1LA6, 1LA7, 1PP5 and 1PP6 only possible for smoke-extraction motors.











# IEC Squirrel-Cage Motors

## Introduction motors 1LA, 1LG, 1LL, 1LP, 1MA, 1MJ, 1PP, 1PQ

### General technical data

0

Connection, circuit and connection box

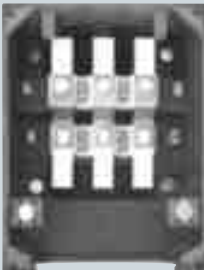
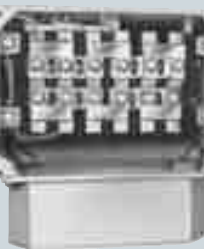
Type gk 030	Type gk 127	Type gk 130, gk 230, gk 330 (not for 1LA5, 1LG4, 1LG6)
		
Type gk 330 (for 1LA5, 1LG4, 1LG6)	Type gk 135, gk 235, gk 335	Type gk 430, gk 431
		
Type 1XB7 222	Type gt 520, gt 540, gt 620, gt 640	Type 1XB7 422, 1XB7 522
		
Type 1XB7 622	Type 1XB1 621	Type 1XB1 631
		

# IEC Squirrel-Cage Motors

## Introduction motors 1LA, 1LG, 1LL, 1LP, 1MA, 1MJ, 1PP, 1PQ

### General technical data

0

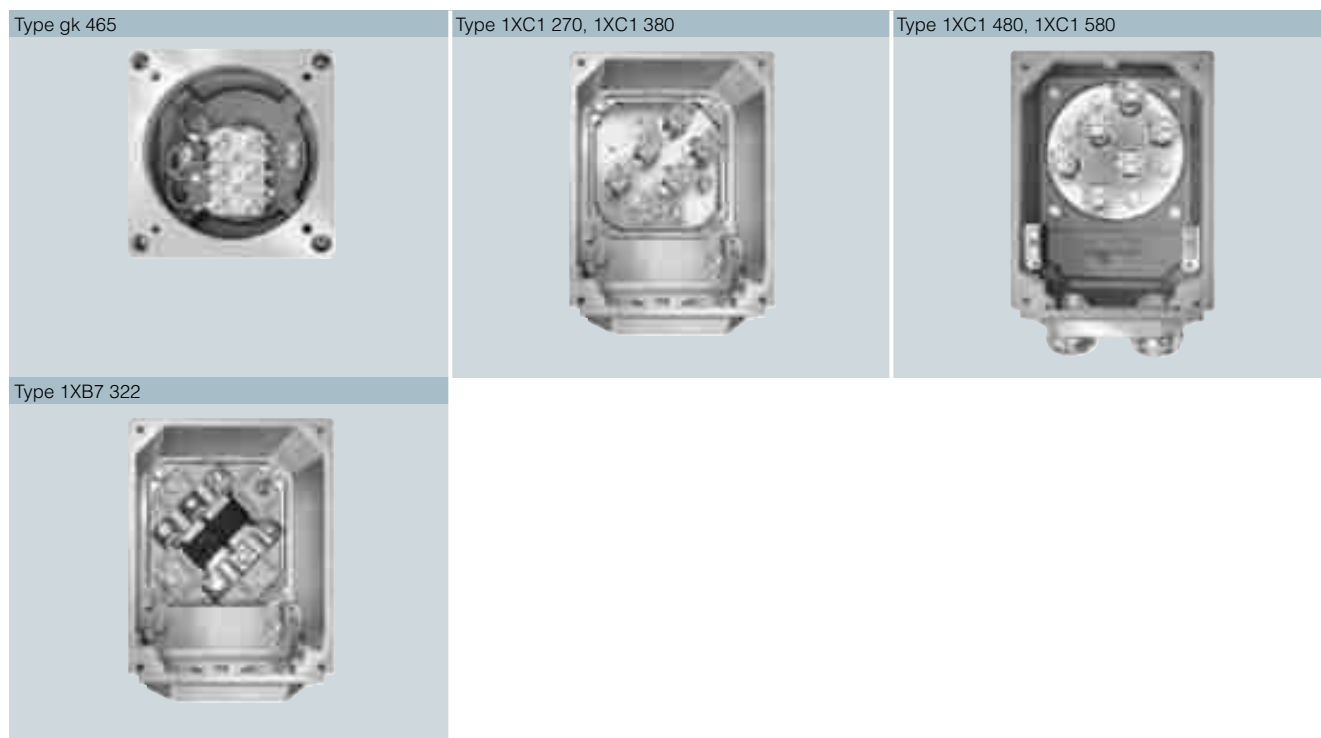

### Connection boxes for 1LA, 1LG, 1LP and 1PP motors

Motors	Frame size	Number of cable entries	Connection box material	Feeder connection
<b>1LA7, 1LA9</b>	56 ... 71	2 cable glands incl. Plugs	Aluminum alloy	Without cable lug or with cable lug
<b>1LP7, 1PP7</b>	80 ... 90			
	100 ... 160	2 holes 180° apart, 4 break-out openings sealed with cast iron skin (2 left, 2 right), connection box is moulded		
<b>1LA5, 1LA9</b>	180 ... 225	2 holes with plugs		
<b>1LP5, 1PP5</b>				
<b>1LA6</b>	100 ... 160		Cast iron	
<b>1LG4, 1LG6</b>	180 ... 200		Aluminum alloy <sup>1)</sup>	Without cable lug
<b>1LP4, 1PP4, 1PP6</b>	225			With cable lug
	250 ... 315			
<b>1LA8, 1PQ8, 1LL8</b>	315 ... 355 <sup>2) 3)</sup>		Cast iron	
	400 ... 450	4 holes with plugs		

### Possible positions of connection boxes for 1LA, 1LG, 1LP and 1PP motors

Motors	Frame size	Connection box position			Rotation of connection box		Retrofitting possible
		top	Side, right or left	Retrofitting possible	90° <sup>4)</sup>	180° <sup>4)</sup>	
<b>1LA5, 1LA7, 1LA9</b>	56 ... 71	○	–	–	○	○	Yes
<b>1LP5, 1LP7</b>	80 ... 90	○	○	–	○	○	Yes
<b>1PP5, 1PP7</b>	100 ... 160	○	○	–	– <sup>5)</sup>	○	Yes
	180 ... 225	○	○	–	○	○	Yes
<b>1LA6</b>	100 ... 160	○	○	–	○	○	Yes
<b>1LG4, 1LG6</b>	180 ... 315	○	○	– <sup>6)</sup>	○	○	Yes
<b>1LP4, 1PP4, 1PP6</b>							
<b>1LA8</b>	315	○	○ <sup>2)</sup>	–	○	○	–
	355	○	○ <sup>2)</sup>	–	○	○	–
	400, 450	○	○ <sup>2)</sup>	–	○	○	–

○ Available version

For further details of 1LA8 motors, see "Dimensions", "1LA8".

<sup>1)</sup> Connection box in cast-iron version **K15**.

<sup>2)</sup> 15° to the vertical in each case

<sup>3)</sup> Frame sizes 357-2 and 357-4 as for frame sizes 400 and 450

<sup>4)</sup> The position of the cable entry must be specified when ordering.

<sup>5)</sup> Design for 1LA7 motors available on request.

<sup>6)</sup> Retrofittable with screwed on feet (order codes **K09**, **K10** and **K11**).

# IEC Squirrel-Cage Motors

## Introduction motors 1LA, 1LG, 1LL, 1LP, 1MA, 1MJ, 1PP, 1PQ

### General technical data

#### Connection boxes for 1LA, 1LG, 1LL, 1LP, 1PP and 1PQ motors in standard version and for Zone 22

See the next section of the catalog for connection boxes for 1LA8, 1PQ8 and 1LL8.

Frame size	Connection box	Number of terminals	Contact screw thread	Max. conductor size	Sealing range	Cable entry <sup>1) 2)</sup>	Cable entry for CSA version order code <b>D40</b> <sup>3)</sup>
	Type			mm <sup>2</sup>	mm	Size	Size
<b>1LA5, 1LA7, 1LA9, 1LP5, 1PP7, 1PP5 and 1PP7</b>							
<b>56</b>	gk 030	6	M4	1.5	9 ... 17	M25 x 1.5	NPT 1/2"
<b>63</b>	(gk 127) <sup>4)</sup>			(2.5 with cable lug)	4.5 ... 10	M16 x 1.5	
<b>71</b>							
<b>80</b>							
<b>90</b>							
<b>100</b>	gk 130	6	M4	4	11 ... 21	2 x M32 x 1.5	NPT 3/4"
<b>112</b>							
<b>132</b>	gk 230	6	M4	6	11 ... 21	2 x M32 x 1.5	NPT 3/4"
<b>160</b>	gk 330	6	M5	16	19 ... 28	2 x M40 x 1.5	NPT 1"
<b>180</b>							NPT 1 1/2"
<b>200</b>	gk 430	6	M6	25	27 ... 35	2 x M50 x 1.5	NPT 2"
<b>225</b>	gk 431	6	M8	35	27 ... 35	2 x M50 x 1.5	
<b>1LA6</b>							
<b>100</b>	gk 135	6	M4	4	11 ... 21	2 x M32 x 1.5	NPT 1/2"
<b>112</b>							
<b>132</b>	gk 235	6	M4	6	11 ... 21	2 x M32 x 1.5	NPT 3/4"
<b>160</b>	gk 335	6	M5	16	19 ... 28	2 x M40 x 1.5	NPT 1"
<b>1LG4, 1LG6, 1LP4, 1PP4 and 1PP6</b>							
<b>180</b>	gk 330	6	M5	16	19 ... 28	M40 x 1.5	M40 x 1.5 <sup>13)</sup>
<b>200</b>	gk 430	6	M6	25	27 ... 35	M50 x 1.5	M50 x 1.5 <sup>13)</sup>
<b>225</b>	gk 431	6	M8	35	27 ... 35	M50 x 1.5	M50 x 1.5 <sup>13)</sup>
<b>250</b>	gt 520	6	M10	120	34 ... 42	M63 x 1.5	M63 x 1.5 <sup>13)</sup>
<b>280</b>							
<b>315</b>	gt 620	6	M12	240 <sup>5)</sup>	38 ... 45	M63 x 1.5	M63 x 1.5 <sup>13)</sup>

The connection box table does not apply to pole-changing motors with three speeds.

A two-part plate can be supplied. Order code **K06**. For frame size 250 M and above, with strain relief.

#### Connection boxes for 1LA8 and 1PQ8 motors in standard version

##### Mains-fed operation

Frame size	Connection box	Number of terminals	Contact screw thread	Max. rec. conductor cross-section	Outer cable diameter (sealing range)	Cable entry <sup>6)</sup>	Cable gland option <b>K57</b> <sup>7)</sup>	Auxiliary lead Outer cable diameter	Cable entry	Two-part plate option <b>K06</b>	Auxiliary lead outer cable diameter
	Type			mm <sup>2</sup>	mm	Size	Size	mm	Size	mm	mm
<b>1LA8 ... 1PQ8 ...</b>											
... <b>315</b>	gt 640	6	M12	185	41.0 ... 56.5	2 x M72x2 + 2 x M20x1.5	2 x M72x2	7 ... 13	2 x M20x1.5	–	–
... <b>317</b>	<sup>8) 9) 11)</sup>										
... <b>353</b>	1XB1 621	6	M16	240	56.0 ... 68.5	2 x M80x2 + 2 x M25x1.5	2 x M80x2	11.5 ... 15.5	2 x M25x1.5	40 ... 70	2 x D80 + 2 x M25x1.5
... <b>355</b>	<sup>8) 10)</sup>										
... <b>357-6</b>											
... <b>357-8</b>											
... <b>357-2</b>	1XB1 631 <sup>10)</sup>	12	M16	240	56.0 ... 68.5	4 x M80x2 + 2 x M25x1.5	4x M80x2	11.5 ... 15.5	2 x M25x1.5	40 ... 75	4 x D80 + 2 x M25x1.5
... <b>357-4</b>	1XB1 631 <sup>12)</sup>										
... <b>40</b>											
... <b>45</b>											

1) Designed for cable glands with O-ring.

2) For 1LA7 motors frame sizes 100 to 160, speed nuts are enclosed for the cable glands.

3) Not possible for motors in Zone 22.

4) (gk 127) For frame sizes 63 to 90, with additional installation of several temperature sensors, order code **A12**, terminal strip for main and auxiliary terminals order code **M69** or a brake, a larger connection box will be necessary. The specified values do not change. The gk 127 is standard for Zone 22.

5) With cable cross-sections  $\geq 240$  mm<sup>2</sup>, it is recommended that the next larger connection box is used (order code **L00**). Alternatively, order a two-part plate (order code **K06**).

6) Others available on request.

7) With option **K57**, the cable glands can be supplied.

8) With option **L00**, the motor can be supplied with the 1XB1 631 connection box (recommended for cable cross-sections  $\geq 240$  mm<sup>2</sup>).

9) Cable entry without removable plate, cable entry in connection box casing.

10) Cable entry with removable plate or supports.

11) With option **M58**, the motor can be supplied with the 1XB1 621 connection box (recommended for cable cross-sections  $> 185$  mm<sup>2</sup>).

12) With option **K11** connection box on top the 1XB1 634 connection box will be supplied.

13) NPT-thread can be ordered with order code **Y61**.

# IEC Squirrel-Cage Motors

## Introduction motors 1LA, 1LG, 1LL, 1LP, 1MA, 1MJ, 1PP, 1PQ

### General technical data

#### Converter-fed operation

Frame size	Connection box	Number of terminals	Contact screw thread	Max. rec. conductor cross-section	Outer cable diameter (sealing range)	Cable entry <sup>1)</sup>	Cable gland option <b>K57</b> <sup>2)</sup>	Auxiliary lead Outer cable diameter	Cable gland option <b>K57</b> <sup>2)</sup>
Type				mm <sup>2</sup>	mm	Size	Size	mm	Size
<b>1LA8 ...</b> <b>1PQ8 ...</b>									
... <b>315</b> ... <b>317</b>	gt 640 <sup>3) 4) 6)</sup>	6	M12	185	41.0 ... 56.5	2 x M72x2 + 2 x M20x1.5	2 x M72x2	9 ... 13	2 x M20x1.5
... <b>353</b> ... <b>355</b> ... <b>357-6</b> ... <b>357-8</b>	1XB1 621 <sup>3) 5)</sup>	6	M16	240	56.0 ... 68.5	2 x M80x2 + 2 x M25x1.5	2 x M80x2	11 ... 16	2 x M25x1.5
... <b>357-2</b> ... <b>357-4</b> ... <b>40</b> ... <b>45</b>	1XB1 631 <sup>5) 7)</sup>	12	M16	240	56.0 ... 68.5	4 x M80x2 + 2 x M25x1.5	4 x M80x2	11 ... 16	2 x M25x1.5

#### Connection boxes for 1LL8 motors in standard version

#### Mains-fed operation

Frame size	Connection box	Number of terminals	Contact screw thread	Max. rec. conductor cross-section	Outer cable diameter (sealing range)	Cable entry <sup>1)</sup>	Cable gland option <b>K57</b> <sup>8)</sup>	Auxiliary lead Outer cable diameter	Cable gland option <b>K57</b> <sup>8)</sup>	Two-part plate option <b>K06</b> Admissible outer cable diameter	Cable entry	Auxiliary lead outer cable diameter
Type				mm <sup>2</sup>	mm	Size	Size	mm	Size	mm	Size	mm
<b>1LL8 ...</b>												
... <b>31</b>	1XB1 621 <sup>9) 5)</sup>	6	M16	240	56.0 ... 68.5	2 x M80x2 + 2 x M25x1.5	2 x M80x2	11.5 ... 15.5	2 x M25x1.5	40 ... 70	2 x D80 + 2 x M25x1.5	11.5 ... 15.5
... <b>35</b>	1XB1 631 <sup>5)</sup>	12	M16	240	56.0 ... 68.5	4 x M80x2 + 2 x M25x1.5	4 x M80x2	11.5 ... 15.5	2 x M25x1.5	40 ... 75	4 x D80 + 2 x M25x1.5	11.5 ... 15.5
... <b>40</b> ... <b>45</b>	1XB1 631 <sup>7)</sup>											

#### Converter-fed operation

Frame size	Connection box	Number of terminals	Contact screw thread	Max. rec. conductor cross-section	Outer cable diameter (sealing range)	Cable entry <sup>1)</sup>	Cable gland option <b>K57</b> <sup>2)</sup>	Auxiliary lead Outer cable diameter	Cable gland option <b>K57</b> <sup>2)</sup>
Type				mm <sup>2</sup>	mm	Size	Size	mm	Size
<b>1LL8 ...</b>									
... <b>31</b>	1XB1 621 <sup>9) 5)</sup>	6	M16	240	56.0 ... 68.5	2 x M80x2 + 2 x M25x1.5	2 x M80x2	11 ... 16	2 x M25x1.5
... <b>35</b>	1XB1 631 <sup>5)</sup>	12	M16	240	56.0 ... 68.5	4 x M80x2 + 2 x M25x1.5	4 x M80x2	11 ... 16	2 x M25x1.5
... <b>40</b> ... <b>45</b>	1XB1 631 <sup>7)</sup>								

<sup>1)</sup> Others available on request.

<sup>2)</sup> Shielded cable (EMC); with option **K57**, the cable glands can be supplied.

<sup>3)</sup> With option **L00**, the motor can be supplied with the 1XB1 631 connection box (recommended for cable cross-sections  $\geq 240$  mm<sup>2</sup>).

<sup>4)</sup> Cable entry without removable plate, cable entry in connection box casing.

<sup>5)</sup> Cable entry with removable plate or supports.

<sup>6)</sup> With option **M58**, the motor can be supplied with the 1XB1 621 connection box (recommended for cable cross-sections  $> 185$  mm<sup>2</sup>).

<sup>7)</sup> With option **K11** connection box on top the 1XB1 634 connection box will be supplied.

<sup>8)</sup> With option **K57**, the cable glands can be supplied.

<sup>9)</sup> With option **L00**, the motor can be supplied with the 1XB1 631 connection box.

# IEC Squirrel-Cage Motors

## Introduction motors 1LA, 1LG, 1LL, 1LP, 1MA, 1MJ, 1PP, 1PQ

### General technical data

#### Connection boxes for 1MA6 and 1MA7 explosion-proof motors and for 1LA6/7/9 and 1LG4/6 motors in Ex n version or for Zone 2 and Zone 21

Motors	Frame size	Number of cable entries	Connection box material	Feeder connection
1MA7, 1LA7, 1LA9	56 <sup>1)</sup> ... 90	2 holes incl. 1 certified cable gland with sealing washer and 1 certified plug	Aluminum alloy	Without cable lug <sup>2)</sup> or with cable lug
	100 ... 160	4 holes incl. 1 certified cable gland with sealing washer and 3 certified plugs		
1MA6, 1LA6	100 ... 160	2 holes incl. 1 certified cable gland with sealing washer and 1 certified plug	Cast iron	
1MA6, 1LA9	180 ... 200	2 holes incl. 1 certified cable gland with sealing washer and 1 certified plug	Aluminum alloy	
	225	2 holes with 2 certified cable glands with sealing washer	Cast iron	
	250 ... 315			
1LG4, 1LG6	180 ... 225	2 holes incl. 1 certified cable gland with sealing washer and 1 certified plug	Aluminum alloy	
	250 ... 315	2 holes with 2 certified cable glands with sealing washer	Cast iron	

#### Connection boxes for 1LA8 and 1PQ8 explosion-proof motors in Ex n version or for Zone 2 and Zone 22

Motors	Frame size	Number of cable entries	Connection box material	Feeder connection
1LA8, 1PQ8	315, 355 <sup>3) 4)</sup> 400, 450	Undrilled cable entry	Cast iron	With cable lug

#### Connection boxes for 1LA8 and 1PQ8 explosion-proof motors in Ex n version or for Zone 2 and Zone 22

Frame size	Connection box	Number of terminals	Contact screw thread	Recommended max. conductor cross-section	Cable entry <sup>5)</sup>	Two-part plate option <b>K06</b>		
						Max. outer cable diameter	Cable entry	Auxiliary lead outer cable diameter
	Type			mm <sup>2</sup>	Size	mm	Size	mm
<b>1LA8 ...</b> <b>1PQ8 ...</b>								
... 315 ... 317	1XB1 621 6) 7)	6	M16	240	Undrilled cable entry 40 ... 70	2 x D80 + 2 x M25x1.5	2 x D80 + 2 x M25x1.5	11.5 ... 15.5
... 353 ... 355 ... 357-6 ... 357-8	1XB1 621 6) 8)	6	M16	240	Undrilled cable entry 40 ... 70	2 x D80 + 2 x M25x1.5	2 x D80 + 2 x M25x1.5	11.5 ... 15.5
... 357-2 ... 357-4 ... 40 ... 45	1XB1 631 8)	12	M16	240	Undrilled cable entry 40 ... 75	4 x D80 + 2 x M25x1.5	4 x D80 + 2 x M25x1.5	11.5 ... 15.5

#### Possible positions of connection boxes for 1MA6 and 1MA7 explosion-proof motors and for 1LA6 and 1LA7 motors in Ex n version or for Zone 2 and Zone 21

Motors	Frame size	Connection box position			Retrofitting possible	Rotation of connection box		Retrofitting possible
		Above	Side, right or left			90° <sup>9)</sup>	180° <sup>9)</sup>	
1MA7 and 1LA7 in Zones 2, 21	56 <sup>10)</sup> ... 71	○	–	–	○	○	Yes	
	80 ... 90	○	○	–	○	○	Yes	
	100 ... 160	○	○	○	–	○ <sup>11)</sup>	Yes	
1MA6 and 1LA6 in Zones 2, 21	100 ... 160	○	○	○	○	○	Yes	
	180 ... 225	○	○	–	○	○	Yes	
	250 ... 315	○	○	–	○	○	Yes	

○ Available version

1) 1MA7 motor series as well as 1LA7/1LA9 motor series in Zone 2, only frame size 63 and above.

2) The components required for connection without cable lugs are supplied with motors of frame size 225 and above as an accessory pack in the connection box.

3) 15° to the vertical in each case.

4) Frame sizes 357-2 and 357-4 as for frame sizes 400 and 450.

5) Others available on request.

6) With option **L00**, the motor can be supplied with the 1XB1 631 connection box (recommended for cable cross-sections  $\geq 240$  mm<sup>2</sup>).

7) Cable entry without removable plate, cable entry in connection box casing.

8) Cable entry with removable plate or supports.

9) The position of the cable entry must be specified when ordering.

10) 1MA7 motor series as well as 1LA7 motor series in Zone 2, only frame size 63 and above.

11) From frame size 100 upwards.

# IEC Squirrel-Cage Motors

## Introduction motors 1LA, 1LG, 1LL, 1LP, 1MA, 1MJ, 1PP, 1PQ

### General technical data

#### Standard connection boxes for 1MA6, 1MA7 explosion-proof motors and for 1LA6, 1LA7, 1LA9, 1LG4 and 1LG6 motors in Ex n, VIK version, Zone 2 and Zone 21

Frame size	Connection box Type	Number of terminals	Contact screw thread	Max. connectable cross-section mm <sup>2</sup>	Sealing range mm	Cable entry <sup>1)</sup> Size	Two-part plate Max. outer cable diameter mm
<b>1MA7, LA7, 1LA9</b>							
56 <sup>2)</sup>	gk 130	6	M4	4	9 ... 17	M25 x 1.5	–
63					4.5 ... 10	M16 x 1.5	
71							
80							
90							
100					14 ... 21	M32 x 1.5	–
112							
132	gk 230	6	M4	6	14 ... 21	M32 x 1.5	–
160	gk 330	6	M5	16	19 ... 28	M40 x 1.5	–
180	1XB7 222	6	M6	10	19 ... 28	M40 x 1.5	–
200	1XB7 322	6	M8	50	26 ... 35	M50 x 1.5	–
<b>1MA6, 1LA6</b>							
100	gk 135	6	M4	4	14 ... 21	M32 x 1.5	–
112							
132	gk 235	6	M4	6			
160	gk 335	6	M5	16	19 ... 28	M40 x 1.5	–
180	1XB7 222	6	M6	10	19 ... 28	M40 x 1.5	–
200	1XB7 322	6	M8	50	26 ... 35	M50 x 1.5	–
225							
250	1XB7 422	6	M10	120	34 ... 42	M63 x 1.5	–
280							
315	1XB7 522	6	M12	240	38 ... 45	M63 x 1.5	–
<b>1LG4, 1LG6</b>							
180	gt 351	6	M6	16	19 ... 27	M40 x 1.5	–
200	gt 451	6	M8	50	24 ... 35	M50 x 1.5	–
225							
250	gt 540	6	M10	120	34 ... 42	M63 x 1.5	–
280							
315	gt 640	6	M12	240	38 ... 45	M63 x 1.5	–

With 1MA motors, unused drilled holes must be sealed in accordance with EN 50014.

#### Connection boxes in Ex de IIC type of protection for explosion-proof motors 1MJ6 and 1MJ7

Motors	Frame size	Number of cable entries	Connection box material	Feeder connection
<b>1MJ6</b>	71 ... 160 M	2 holes incl. 1 certified cable gland with sealing washer and 1 certified plug	Aluminum alloy	Without cable lug <sup>3)</sup> or with cable lug
	160 L		Cast iron	
	180 ... 200		Aluminum alloy	
<b>1MJ7</b>	225	2 holes with 2 certified cable glands with sealing washer	Cast iron	
	250 ... 315			

#### Possible positions of the connection boxes in Ex de type of protection for explosion-proof motors 1MJ6 and 1MJ7

Motors	Frame size	Connection box position			Rotation of connection box		Retrofitting possible
		Above	Side, right or left	Retrofitting possible	90° <sup>4)</sup>	180° <sup>4)</sup>	
<b>1MJ6</b>	71 ... 200	○	○	–	○	○	Yes
<b>1MJ7</b>	225 ... 315	○	○	–	○	○	Yes

○ Available version

<sup>1)</sup> Designed for cable glands with O-ring.

<sup>2)</sup> 1MA7 motor series as well as 1LA7/1LA9 motor series in Zone 2, only frame size 63 and above.

<sup>3)</sup> The components required for connection without cable lugs are supplied with 1MJ7 motors of frame size 225 M and above as an accessory pack in the connection box.

<sup>4)</sup> The position of the cable entry must be specified when ordering.



# IEC Squirrel-Cage Motors

## Introduction motors 1LA, 1LG, 1LL, 1LP, 1MA, 1MJ, 1PP, 1PQ

### General technical data

#### Standard connection boxes in Ex de type of protection for explosion-proof motors 1MJ6 and 1MJ7

Frame size	Connection box	Number of terminals	Contact screw thread	Max. connectable cross-section mm <sup>2</sup>	Sealing range mm	Cable entry <sup>1)</sup>
	Type					Size
<b>1MJ6, 1MJ7</b>						
<b>71</b>	gk 330	6	M4	4	9 ... 17	2 x M25 x 1.5
<b>80</b>						1 x M16 x 1.5
<b>90</b>	gk 420	6	M4	6	9 ... 17	
<b>100</b>					11 ... 21	2 x M32 x 1.5
<b>112</b>	gk 420	6	M4	6	11 ... 21	1 x M16 x 1.5
<b>132</b>						
<b>160 M</b>	gk 420	6	M4	6	19 ... 28	2 x M40 x 1.5
<b>160 L</b>	gk 465	6	M5	16		1 x M16 x 1.5
<b>180</b>	1XC1 270	6	M6	25	19 ... 28	2 x M40 x 1.5 Version with auxiliary circuit 2 x M40 x 1.5 2 x M16 x 1.5
<b>200</b>	1XC1 380	6	M8	50	26 ... 35	2 x M50 x 1.5
<b>225</b>						Version with auxiliary circuit 2 x M50 x 1.5 2 x M16 x 1.5
<b>250</b>	1XC1 480	6	M10	120	34 ... 42	2 x M63 x 1.5
<b>280</b>						
<b>315</b>	1XC1 580	6	M12	240	38 ... 45	2 x M63 x 1.5

With 1MJ motors, unused drilled holes must be sealed in accordance with EN 50014.

#### Connection boxes in cast iron version (order code K15) for motors 1LG4, 1LG6 and 1MA6, 1MJ6, 1MJ7 explosion-proof motors

Motors	Frame size	Number of cable entries	Connection box material	Feeder connection
<b>1MJ6</b>	71 ... 160 M 180 ... 200	2 holes incl. 1 certified cable gland with sealing washer and 1 certified plug	Cast iron	Without cable lug <sup>3)</sup> or with cable lug
<b>1LG4, 1LG6, 1MA6, 1MJ7</b>	180 ... 225	2 holes incl. 2 certified cable glands with sealing washer and 1 certified plug	Cast iron	

#### Possible positions of the connection boxes in cast iron version (order code K15) for 1LG4, 1LG6 motors and 1MA6, 1MJ6, 1MJ7 explosion-proof motors

Motors	Frame size	Connection box position			Rotation of connection box		
		Above	Side, right or left	Retrofitting possible	90° <sup>4)</sup>	180° <sup>4)</sup>	Retrofitting possible
<b>1MJ6</b>	71 ... 80	○	–	–	○	○	Yes
	90 ... 160 M	○	○	–	○	○	Yes
	180 ... 200	○	○	–	○	○	Yes
<b>1LG4, 1LG6, 1MA6, 1MJ7</b>	180 ... 225	○	○	–	○	○	Yes

○ Available version

- 1) Designed for cable glands with O-ring.
- 2) Standard version with cable entry glands split lengthwise for 35 to 75 mm and strain relief.
- 3) The components required for connection without cable lugs are supplied with 1MJ7 motors of frame size 225 M and above as an accessory pack in the connection box.
- 4) The position of the cable entry must be specified when ordering.

# IEC Squirrel-Cage Motors

## Introduction motors 1LA, 1LG, 1LL, 1LP, 1MA, 1MJ, 1PP, 1PQ

### General technical data

#### Connection boxes in cast iron version (order code K15) for motors 1LG4, 1LG6 and 1MA6, 1MJ6, 1MJ7 explosion-proof motors

Frame size	Connection box Type	Number of terminals	Contact screw thread	Max. connectable cross-section mm <sup>2</sup>	Sealing range mm	Cable entry <sup>1)</sup> Size
<b>1MJ6</b>						
<b>71</b>	gk 065	6	M4	4	9 ... 17	2 x M25 x 1.5 1 x M16 x 1.5
<b>80</b>						
<b>90</b>				6		
<b>100</b>	gk 065	6	M4	6	11 ... 21	2 x M32 x 1.5 1 x M16 x 1.5
<b>112</b>	gk 265	6	M4	6	11 ... 21	2 x M32 x 1.5 1 x M16 x 1.5
<b>132</b>	gk 465	6	M4	6	11 ... 21	2 x M32 x 1.5 1 x M16 x 1.5
<b>160 M</b>	gk 465	6	M4	6	19 ... 28	2 x M40 x 1.5 1 x M16 x 1.5
<b>160 L <sup>2)</sup></b>	gk 465	6	M5	16	19 ... 28	2 x M40 x 1.5 1 x M16 x 1.5
<b>180</b>	1XC1 290	6	M6	25	26 ... 35	2 x M50 x 1.5 Version with auxiliary circuit: 2 x M50 x 1.5 2 x M16 x 1.5
<b>200</b>	1XC1 390	6	M8	50	26 ... 35	2 x M50 x 1.5 Version with auxiliary circuit: 2 x M50 x 1.5 2 x M16 x 1.5
<b>1LG4, 1LG6</b>						
<b>180</b>	gt 320	6	M5	16	19 ... 28	M40 x 1.5
<b>200</b>	gt 420	6	M6	25	24 ... 35	M50 x 1.5
<b>225</b>	gt 421	6	M8	25	24 ... 35	M50 x 1.5
<b>1MA6</b>						
<b>180</b>	1XB7 323	6	M8	50	24 ... 35	M50 x 1.5
<b>200</b>	1XB7 323	6	M8	50	24 ... 35	M50 x 1.5

With 1MJ motors, unused drilled holes must be sealed in accordance with EN 50014.

#### Explosion-proof connection boxes in Ex d IIC type of protection (order code K53) for explosion-proof motors 1MJ6 and 1MJ7

Motors	Frame size	Number of cable entries	Connection box material	Feeder connection <sup>3)</sup>
<b>1MJ6</b>	71 ... 200	In standard version: 1 certified plug In versions with PTC thermistors: 2 certified plugs	Cast iron	Without cable lug <sup>4)</sup> or with cable lug
<b>1MJ7</b>	225	In standard version: 1 certified cable gland and 1 certified plug In versions with auxiliary circuit: 2 certified cable glands	Welded steel	
	250 ... 315			

#### Possible positions of the explosion-proof connection boxes in Ex d IIC type of protection (order code K53) for explosion-proof motors 1MJ6 and 1MJ7

Motors	Frame size	Connection box position			Rotation of connection box		Retrofitting possible
		Above	Side, right or left	Retrofitting possible	90° <sup>5)</sup>	180° <sup>5)</sup>	
<b>1MJ6</b>	71 ... 80	○	–	–	○	○	Yes
	90 ... 200	○	○	–	○	○	Yes
<b>1MJ7</b>	225 ... 315	○	○	–	○	○	Yes

○ Available version

<sup>1)</sup> Designed for cable glands with O-ring.

<sup>2)</sup> With 1MJ6 frame size 160 L, option **K15** is the standard version. The connection box corresponds to the standard connection box.

<sup>3)</sup> The number of cables and their outer cable diameter must be specified when ordering – does not apply to 1MJ7 motors.

<sup>4)</sup> The components required for connection without cable lugs are supplied with 1MJ7 motors of frame size 225 M and above as an accessory pack in the connection box.

<sup>5)</sup> The position of the cable entry must be specified when ordering.

# IEC Squirrel-Cage Motors

## Introduction motors 1LA, 1LG, 1LL, 1LP, 1MA, 1MJ, 1PP, 1PQ

### General technical data

#### Explosion-proof connection boxes in Ex d IIC type of protection (order code K53) for explosion-proof motors 1MJ6 and 1MJ7

Frame size	Connection box Type	Number of terminals	Contact screw thread	Max. connectable cross-section mm <sup>2</sup>	Sealing range mm	Cable entry Size
<b>1MJ6, 1MJ7</b>						
<b>71</b>	gk 065d	6	M4	4		Standard: 1 x M25 x 1.5 <sup>1)</sup>
<b>80</b>						Version with auxiliary circuit: 1 x M25 x 1.5 1 x M20 x 1.5
<b>90</b>						6
<b>100</b>	gk 065d	6	M4	6		Standard: 1 x M32 x 1.5 <sup>1)</sup>
<b>112</b>	gk 265d	6	M4	6		Version with auxiliary circuit: 1 x M32 x 1.5 1 x M20 x 1.5
<b>132</b>	gk 465d	6	M4	6		
<b>160 M</b>	gk 465d	6	M4	6		Standard: 1 x M40 x 1.5 <sup>1)</sup>
<b>160 L</b>	gk 465d	6	M5	16		Version with auxiliary circuit: 1 x M40 x 1.5 1 x M20 x 1.5
<b>180</b>	1XC3 22.	6	M6	25		Standard: 1 x M40 x 1.5 <sup>1)</sup>
						Version with auxiliary circuit: 1 x M40 x 1.5 1 x M20 x 1.5
<b>200</b>	1XC3 32.	6	M8	50		Standard: 1 x M50 x 1.5 <sup>1)</sup>
						Version with auxiliary circuit: 1 x M50 x 1.5 1 x M20 x 1.5
<b>225</b>	1XC3 32.	6	M8	50	M40: 23.5 ... 32 M20: 6.5 ... 12	Standard: 1 x M40 x 1.5 1 x plug M40 x 1.5
						Version with auxiliary circuit: 1 x M40 x 1.5 1 x M20 x 1.5
<b>250</b>	1XC3 42.	6	M10	120	M50: 31.5 ... 44 M20: 6.5 ... 12	Standard: 1 x M50 x 1.5
<b>280</b>						1 x plug M50 x 1.5
						Version with auxiliary circuit: 1 x M50 x 1.5 1 x M20 x 1.5
<b>315</b>	1XC3 52.	6	M12	240	M50: 31.5 ... 44 M20: 6.5 ... 12	Standard: 1 x M50 x 1.5 1 x plug M50 x 1.5
						Version with auxiliary circuit: 1 x M50 x 1.5 1 x M20 x 1.5

With 1MJ motors, unused drilled holes must be sealed in accordance with EN 50014.

#### Terminal connection

The terminal board accommodates the terminals that are connected to the leads to the motor windings. The terminals are designed so that up to frame size 225, the external (line) connections can be made without the need for cable lugs. With frame size 250 and above, standard connection is with cable lugs.

For the 1LG4/1LG6/1LP4/1PP4 motor series, for frame sizes 250 to 315, stud terminals are available for connection using cable lugs (accessory pack, 3 items).

Order code **M46**

With frame size 250 and above, if connection without cable lugs is required, the appropriate saddle terminals for connection without cable lugs (accessory pack, 6 items) must be ordered for motor series 1LG4/1LG6/1LP4/1PP4 frame sizes 250 to 315. In the connection box of 1MJ7 Ex motors, frame sizes 250 M to 315 L, 6 low saddle terminals are enclosed as standard for connection without cable lugs. When connecting cables with a large cross-section (not stranded), they can be connected optionally in two tiers. For this purpose, high saddle terminals can be supplied in the future as an accompanying pack (3 items).

Order code **M47**

For Exe and Exde motors, connection is generally without cable lugs.

The terminal board is permanently mounted on the housing for all motors so that if the connection box is rotated, rotation of the connections for the motor windings is prevented.

Exception:

With connection boxes 1XB1 621 and 1XB1 631, the terminal support is mounted on the lower section of the connection box.

For motor series 1LA7/1LP7/1PP7 frame sizes 63 to 90, a terminal strip can be supplied for the main and auxiliary terminals.

Order code **M69**

<sup>1)</sup> Designed for explosion-proof cable glands. The drilled holes for cable entry are closed with plugs certified for explosion-proof applications.

# IEC Squirrel-Cage Motors

## Introduction motors 1LA, 1LG, 1LL, 1LP, 1MA, 1MJ, 1PP, 1PQ

### General technical data

#### Number of auxiliary terminals for 1LA, 1LG, 1LL, 1LP, 1PP and 1PQ motors – Standard version

Motor series 1LA5, 1LA6, 1LA7, 1LP5, 1LP7, 1PP5, 1PP7 have no auxiliary terminals in the standard version.

The maximum number of auxiliary terminals in the main connection box of the motor is specified. An auxiliary connection box is required when the total number of auxiliary terminals exceeds the specified values. The connections can be routed through a separate auxiliary connection box.

For motor series

- 1LA8, 1PQ8 and 1LL8 frame sizes 315 to 450
- 1MA6 frame sizes 225 to 315
- 1MJ7 frame sizes 225 to 315

the 1XB3 020 connection box is available.

Order code **L97**

For non-standard motors (1LA8, 1PQ8 and 1LL8 motor series), the following can be supplied:

1XB9 016 auxiliary connection box – Order code **M50**

1XB9 014 auxiliary connection box (aluminum) – Order code **M88**

Type series	Frame size	Main connection box	Maximum No. of auxiliary terminals
1LG4, 1LG6, 1LP4, 1PP4, 1PP6	180	gk 330	4
	200	gk 430	10
	225	gk 431	10
	250	gt 520	12
	280		
	315	gt 620	18
1MA6	225	1XB7 322	8
	250	1XB7 422	12
	280		
	315	1XB7 522	14
1MJ7	225	1XC1 380	4
	250	1XC1 480	
	280		
	315	1XC1 580	6
1LA8, 1PQ8, 1LL8	315	gt 640	6
	355	1XB1 621	12
	400	1XB1 631	24
	450		

# IEC Squirrel-Cage Motors

## Introduction motors 1LA, 1LG, 1LL, 1LP, 1MA, 1MJ, 1PP, 1PQ

General technical data

### ECOFAST system

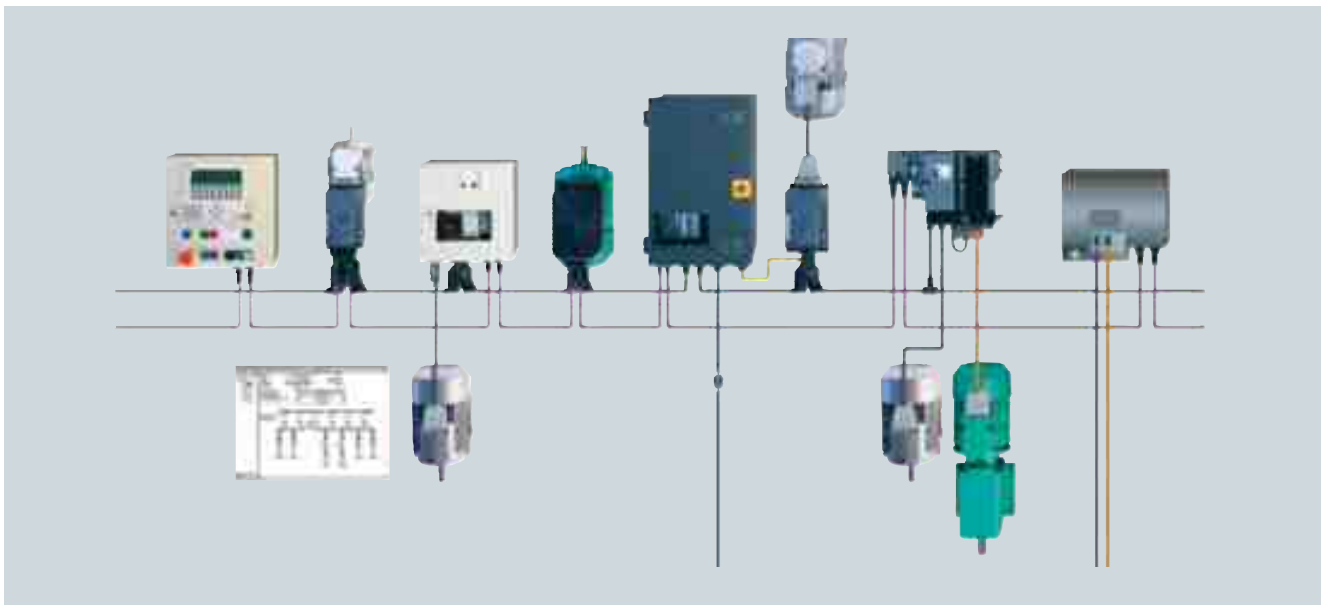

ECOFAST is a system which permits extensive decentralization and a modular structure for installation elements on the component level.

The following motor connectors are available for the separate MICROMASTER 411 frequency converter:

- ECOFAST motor connector Han Drive 10e for 230 VΔ/400 VY  
Order code **G55**
- ECOFAST motor connector EMC Han Drive 10e for 230 VΔ/400 VY  
Order code **G56**

In the basic version, cable entry for the ECOFAST connector is towards the non-drive end (NDE). The dimensions of the ECOFAST motor connector depend on the motor frame size and can be read from the dimension drawing generator for motors in the tool "Selection tool SD configurator" (see Appendix). It is particularly important to check the dimensions when a brake with a manual release lever is used towards the non-drive end (NDE) due to possible collision of the motor connector and manual release lever as well as in the direction of the drive end (DE) due to possible collision with drive units such as coupling or gear wheels.

#### Advantages:

The main advantages of the ECOFAST motor connector over a terminal strip are as follows:

- Fast assembly of I/O devices (e.g. motor starters) from the ECOFAST system.
- Reduction of assembly and repair times at the end user
- No wiring errors due to connector technology
- Replacement of motor without intervention in the electronics

Main features of the ECOFAST motor connector (with separate MICROMASTER 411 frequency converter):

The motor connector is mounted at the factory and replaces the connection box with terminal board. The connector is mounted towards the non-drive end (NDE). It comprises an angled motor connection casing that can be rotated by  $4 \times 90^\circ$ . A 10-pole (+ earth) male insert is used in the housing. In the plug-in connector, the winding connections are connected and optionally the power supply for the brake and the signal leads for the temperature sensors. The ECOFAST motor connector is compatible with the products of the ECOFAST field device system. Further information can be found in Catalog IK PI.

The mounting dimensions of this casing match those of standard industrial connectors, so it is possible to use a complete series of different standard inserts (such as Han E, ES, ESS from Harting). The motor circuit (star or delta connection) is selected in the mating connector for motor connection. The relevant jumpers are inserted by the customer in the mating connector. As a casing for the mating connector, all standard sleeve casings with lengthwise locking, frame size 10B (e.g. from Harting) can be used.

#### Note:

Only one sensor (temperature sensor or PTC thermistor) can be connected. The admissible mains voltage at the motor connector is  $\leq 500$  V

#### Availability of the ECOFAST motor connector

The ECOFAST motor connector can be supplied for the following motor versions with the exception of the explosion-proof motors:

- Frame sizes 56 M to 132 M
- Output range 0.06 to 5.5 kW (7.5 kW on request)
- Direct on-line starting: Voltage code **1** for 230 VΔ/400 VY, 50 Hz
- Star-delta starting: Voltage code **9** with order code **L1U** 400 VΔ, 50 Hz

#### Further details:

Further information can be found in Catalog IK PI and in Catalog DA 51.3 "Distributed Drive Solutions MICROMASTER 411 COMBIMASTER 411" as well as on the Internet at:

<http://www.siemens.com/ecofast>

# IEC Squirrel-Cage Motors











## Introduction motors 1LA, 1LG, 1LL, 1LP, 1MA, 1MJ, 1PP, 1PQ

### General technical data

0

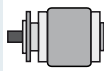
#### Types of construction

##### Standard types of construction and special types of construction

Type of construction acc. to DIN EN 60034-7		Frame size	Code 12th position	Order code
<b>Without flange</b>				
IM B3		56 M to 450	0 <sup>4)</sup>	–
IM B6/IM 1051, IM B7/IM 1061, IM B8/IM 1071	  	56 M to 315 L	0	–
IM V5/IM1011 without protective cover		56 M to 315 M 315 L	0 <sup>5)</sup> 9 <sup>1)5)</sup>	– <b>M1D</b>
IM V6/IM 1031		56 M to 315 M 315 L	0 9 <sup>1)</sup>	– <b>M1E</b>
IM V5/IM 1011 with protective cover		63 M to 315 L	9 <sup>1)7)</sup>	<b>M1F</b>
<b>With flange</b>				
IM B5/IM 3001		56 M to 315 M	1 <sup>2)</sup>	–
IM V1/IM 3011 without protective cover		56 M to 315 M 315 L to 450	1 <sup>2)3)5)</sup> 8 <sup>1)4)5)</sup>	– –
IM V1/IM 3011 with protective cover		63 M to 450	4 <sup>1)2)3)7)</sup>	–
IM V3/IM 3031		56 M to 160 L 180 M to 315 M	1 9 <sup>2)3)</sup>	– <b>M1G</b>
IM B35/IM 2001 <sup>6)</sup>		56 M to 450	6 <sup>4)</sup>	–

In the DIN EN 50347 standard, flange FF with through holes and flange FT with tapped holes are specified.





- 1) For 2-pole 1LG4 and 1LG6 motors, of frame size 315 L, a 60 Hz version is possible on request.
- 2) 1LG4/1LG6, 1MA6 and 1MJ7 motors in frame sizes 225 S to 315 L are supplied with two screw-in eyebolts (four eyebolts for 1LG6 318) in accordance with IM B5, whereby one can be rotated in accordance with IM V1 or IM V3. It is important to note that stress must not be applied perpendicular to the ring plane.
- 3) For frame sizes 180 M to 225 M, the 1LA5 motors can be supplied with two additional eyebolts; state Order No. suffix "Z" and order code **K32**.
- 4) Frame size 450, 2-pole, 60 Hz is not possible.

- 5)  For explosion-proof motors: For types of construction with shaft extension pointing downwards, the version "with protective cover" is mandatory. For types of construction with shaft extension pointing upwards, a suitable cover must be implemented to prevent small parts from falling into the fan cover (see the standard IEC/EN 60079-0). The cover must not block the cooling air-flow.
- 6) In the case of 1LA8, the corresponding flange diameter is greater than twice the shaft height.
- 7) A second **K16** shaft extension is not possible.

# IEC Squirrel-Cage Motors

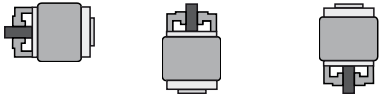
## Introduction motors 1LA, 1LG, 1LL, 1LP, 1MA, 1MJ, 1PP, 1PQ

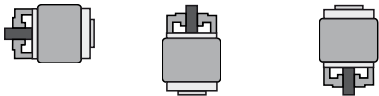
### General technical data

Type of construction acc. to DIN EN 60034-7	Frame size	Code 12th position	Order code
<b>With standard flange</b>			
IM B14/IM 3601, IM V19/IM 3631, IM V18/IM 3611 without protective cover	 56 M to 160 L	<b>2</b> <sup>2) 4)</sup>	–
IM V 18/IM 3611 with protective cover	 63 M to 160 L	<b>9</b> <sup>1) 2)</sup>	<b>M2A</b>
IM B34/IM 2101	 56 M to 160 L	<b>7</b> <sup>2) 4)</sup>	–
<b>With special flange</b>			
IM B14/IM 3601, IM V19/IM 3631, IM V18/IM 3611 without protective cover	 56 M to 160 L	<b>3</b> <sup>3) 4)</sup>	–
IM V18/IM 3611 with protective cover	 63 M to 160 L	<b>9</b> <sup>1) 3)</sup>	<b>M2B</b>
IM B34/IM 2101	 56 M to 160 L	<b>9</b> <sup>3)</sup>	<b>M2C</b>

In DIN EN 50347, standard flanges are assigned to the frame sizes as FT with tapped holes. The special flange was assigned as a large flange in the previous DIN 42677.

The dimensions of the following types of construction are identical:

IM B3, IM B6, IM B7, IM B8, IM V5 and IM V6  
IM B5, IM V1 and IM V3  
IM B14, IM V18 and IM V19

Motors in the standard output range can be ordered in basic types of construction IM B3, IM B5 or IM B14 and operated in mounting positions IM B6, IM B7, IM B8, IM V5, IM V6, IM V1, IM V3 (up to frame size 160 L) or IM V18 and IM V19. Eyebolts are available for transport and installation in a horizontal position. In conjunction with the eyebolts, for the purpose of stabilizing the position when the motor is arranged vertically, additional lifting straps (DIN EN 1492-1) and/or clamping bands (DIN EN 12195-2) must be used. If mounting position IM V1 is ordered, eyebolts are supplied for vertical mounting.

- For this reason, they are normally designated only with the basic type of construction on the rating plate.
- If motors of frame size 180 M in a type of construction with feet are mounted on the wall, it is recommended that the motor feet are supported.

With motors that have a vertical shaft extension, the end user must prevent an ingress of fluid along the shaft.

In the case of all types of construction with shaft extension down, the version "with protective cover" is urgently recommended, see the section "Degrees of protection".

Motor series 1LA8, 1PQ8 and 1LL8 are available in types of construction IM B3, IM V1 with and without cover, as well as IM B35.

#### Frame design

Motors in the types of construction with feet have, in some case, two fixing holes at the non-drive end (NDE), see dimension tables. A code is cast into the motor close to the retaining holes to identify the frame size.

<sup>1)</sup> A second **K16** shaft extension is not possible.

<sup>2)</sup> For 1MJ6 motors, only possible up to frame size 90.

<sup>3)</sup> For 1MJ6 motors, only possible up to frame size 80.

<sup>4)</sup>  For explosion-proof motors: For types of construction with shaft extension pointing downwards, the version "with protective cover" is mandatory. For types of construction with shaft extension pointing upwards, a suitable cover must be implemented to prevent small parts from falling into the fan cover (see the standard IEC/EN 60079-0). The cover must not block the cooling air-flow.

# IEC Squirrel-Cage Motors

## Introduction motors 1LA, 1LG, 1LL, 1LP, 1MA, 1MJ, 1PP, 1PQ

### General technical data

#### Mechanical design and degrees of protection

##### Preparation for gear mounting

The flange-mounting motors can be equipped with a radial seal in order to mount gearing.  
Order code **K17**.

It must be ensured that the sealing ring is lubricated using grease, oil mist or oil spray (it is not permissible to use pressurized oil > 0.1 bar).

We recommend that the admissible bearing loads are carefully checked.

Please inquire about gear mounting for 1LA8 non-standard motors.

##### Eyebolts and transport

1LA7, 1MA7 and 1LA5 motors of frame size 100 L and above have two horizontal eyebolts in the horizontal type of construction. For motors in vertical type of construction, two rotatable eyebolts are also supplied.

1LA6 and 1MA6 motors are supplied in a horizontal type of construction with feet complete with one eyebolt.

Horizontal types of construction for flange-mounting in frame sizes 100 to 160 are supplied with one eyebolt. With vertical types of construction, a rotatable eyebolt is also supplied. All flange-mounting types of construction in frame sizes 180 M to 315 L are supplied with two diagonal eyebolts. They can be relocated for vertical types of construction.

1LG4 and 1LG6 motors are supplied in a horizontal type of construction with two diagonal eyebolts. For vertical types of construction, the eyebolts can be rotated.

All the available eyebolts specifically provided for the type of construction must be used during transport.

1MA6, 1MJ6 and 1MJ7 motors of frame size 180 M and above have one eyebolt in type of construction IM B3 in the standard version and two eyebolts in type of construction IM B5. If type of construction IM V1 is used, one of the eyebolts must be rotated whereby it is important to note that forces perpendicular to the ring plane are not permitted.

1LA8, 1PQ8 and 1LL8 motors have two diagonally fixed eyebolts. The IM V1 types of construction have hinged eyebolts.

1MJ6 motors, frame sizes 90 L to 132 M have two eyebolts, frame sizes 160 M and 160 L have one eyebolt.

For frame sizes 180 M to 225 M, 1LA5 motors can be supplied with two additional eyebolts for types of construction IM V1/IM V3.

Order code **K32**

Frame material			
Type series	Frame size	Frame material	Frame feet
<b>1LA5, 1LA7, 1LA9</b>	56 to 100 <sup>1)</sup> 112 to 225	Aluminum alloy Aluminum alloy	Cast Screwed on
<b>1MA7</b>	63 to 100 <sup>1)</sup> 112 to 160	Aluminum alloy Aluminum alloy	Cast Screwed on
<b>1LG4, 1LG6</b>	180 M to 315 L	Cast iron	Cast <sup>2)</sup>
<b>1LA6, 1MA6</b>	100 to 200 225 to 315 M 315 L	Cast iron Cast iron Cast iron	Screwed on Cast Screwed on
<b>1MJ6</b>	71 and 80 90 to 200	Cast iron Cast iron	Cast Screwed on
<b>1MJ7</b>	225 to 315	Cast iron	Screwed on
<b>1LA8, 1PQ8, 1LL8</b>	315 to 450	Cast iron	Cast

<sup>1)</sup> Frame sizes 80, 90 and 100 in the version "Connection box on LHS/RHS" order code **K09/K10** have feet that are screwed on.

<sup>2)</sup> Basic version, cast feet: Special version "screwed on feet" for order codes **K09, K10** and **K11**.

##### Degrees of protection

All motors are designed to IP55 degree of protection. They can be installed in dusty or humid environments. The motors are suitable for operation in tropical climates. Guide value <60 % relative air humidity at CT 40 °C. Other requirements are available on request.

1LL8 motors are available to IP23 degree of protection and are of a similar construction to 1LA8 motors. IP23 degree of protection is achieved by opening the internal cooling circuit and supplying it with external cooling air. Motors of the 1LL8 type series are only intended for installation indoors. They must not be subjected to humid, salty or corrosive atmospheres.

Most motors can be supplied in IP56 and IP65 degrees of protection on request.

##### Brief explanation of the degrees of protection

**IP55:** Protection against harmful dust deposits, protection against water jets from any direction.

##### IP56 (non-heavy-sea):

Protection against harmful dust deposits, protection against water jets from any direction.

##### Order code **K52**

DIN EN 60034-5 defines protection level 6 for water protection as: "Protection against water due to heavy seas or water in a powerful jet". IP56 non-heavy-sea degree of protection can only be used with the requirement "Protection against a powerful jet" and not for the requirement "Protection against heavy sea".

This is not possible in combination with brake 2LM8 (used for motors up to and including frame size 225, order code G26) and/or in combination with order code (K23) without paint finish, cast iron primed.

**IP65:** Complete protection against dust deposits, protection against water jets from any direction.

##### Order code **K50**

In DIN EN 60034-5, the code 6 for protection against the ingress of foreign bodies and touch hazard protection for electrical machines is not listed – Data for code 6 (protection against the ingress of dust) is given in EN 60529.

Not possible in combination with rotary pulse encoder HOG 9 D 1024I (order code H72, H79) and / or brake 2LM8 (used for motors up to and including frame size 225, order code G26) and/or in combination with order code (K23) without paint finish, cast iron primed.

DIN EN 60529 contains a comprehensive description of this degree of protection as well as test conditions.

With motors that have a vertical shaft extension, the end user must prevent an ingress of fluid along the shaft.

For motors with shaft extension pointing downwards, the version "with protective cover" is urgently recommended, see "Types of construction".

With flange-mounting motors, for IM V3 type of construction, collection of fluid in the flange basin can be prevented by drainage holes (on request).

Drainage holes are usually available in 1MA6 and 1MA7 motors of frame size 225 and above and in all 1LG4 and 1LG6 motors.

1LG4, 1LG6, 1LA8, 1LL8, 1PQ8 motors and 1MA6 motors of frame size 225 and above have condensation drainage holes that are sealed with plugs.

Motors for Zones 2 and 21 (1MA6 of frame size 225 and above and 1LG4 and 1LG6) have condensation drainage holes that are sealed with screws.

Condensation drainage holes can also be implemented in motors designed for Zones 2, 21 and 22.

The condensation drainage holes at the drive end (DE) and non-drive end (NDE) are sealed (IP55) on delivery. If condensation drainage holes are required in motors of the IM B6, IM B7 or IM B8 type of construction (feet located on side or top), it is necessary to relocate the bearing plates at the drive end (DE) and non-drive end (NDE) so that the condensation drainage holes situated between the feet on delivery are underneath.

Order code **L12**



When the motors are used or are stored outdoors (not 1LL8) we recommend that they are kept under some sort of cover so that they are not subject to direct intensive solar radiation, rain, snow, ice or dust over a long period of time. In such cases, technical consultation may be appropriate.

When the motors are used outdoors or in a corrosive environment, it is recommended that non-rusting screws are used externally.

Order code **M27**

Vibration-proof version

A load of 1.5g in all 3 planes for up to 1 % of the service life of the motor is possible.

Order code **L03**

For availability of individual options for the relevant motor series, see Section "Special versions" in the individual catalog parts.

#### Noise levels for mains-fed operation

The noise levels are measured in accordance with DIN EN ISO 1680 in a dead room. It is specified as the A-weighted measuring-surface sound pressure level  $L_{pFA}$  in dB (A).

This is the spatial mean value of the sound pressure levels measured on the measuring surface. The measuring surface is a cube 1 m away from the surface of the motor. The sound power level is also specified as  $L_{WA}$  in dB (A).

The specified values are valid at 50 Hz at rated output (see the selection and ordering data in the appropriate catalog parts).

The tolerance is +3 dB. At 60 Hz, the values are approximately 4 dB (A) higher. Please inquire about the noise levels for pole-changing motors, motors with increased output or converter-fed motors.

To reduce noise levels, 2-pole motors with frame size 132 S and above and 1LA8 and 1LL8 2-pole motors of frame size 315 can be fitted with an axial-flow fan that is only suitable for one direction of rotation. The values can be taken from the table "Low-noise version" below and for 1LA8 or 1LL8 2-pole motors from the selection and ordering data in catalog part 3 "Non-standard motors of frame size 315 and above".

Clockwise rotation

Order code **K37**

Counter-clockwise rotation

Order code **K38**

The motors up to frame size 315 L are up to 80 mm longer than normal.

A second shaft extension and/or mounting of an encoder are not possible (see "Special versions" in the relevant catalog parts).

Low-noise version			
Type series	Frame size	2-pole motors	
		$L_{pFA}$ dB (A)	$L_{WA}$ dB (A)
<b>1LA5, 1LA6, 1LA7, 1MA7, 1MA6, 1MJ6, 1MJ7</b>	132	64	76
	160	64	76
	180	63	76
	200	63	76
	225	68	80
	250	70	82
	280	72	84
315	74	86	
<b>1LG4, 1LG6<sup>1)</sup></b>	180	65	78
	200	70	83
	225	68	81
	250	70	83
	280	72	85
	315	74	87

<sup>1)</sup> Not necessary for 1LG6 motors because these motors are already noise optimized.

Earth brushes are available for converter-fed operation for 1LG4 and 1LG6 motors.

Order code **M44**

Only available on request.

The rotary pulse encoders of "modular technology" and "special technology" are fitted as standard with a protective cover made of plastic, with the exception of 1LG motors. A protective cover made of non-corrosive sheet steel is available for 1LA5, 1LA6 and 1LA7 motors, see "Mechanical protection for encoders".

Order code **M68**

# IEC Squirrel-Cage Motors

## Introduction motors 1LA, 1LG, 1LL, 1LP, 1MA, 1MJ, 1PP, 1PQ

### General technical data

#### Balance and vibration quantity

All of the rotors are dynamically balanced with half key. This corresponds to vibration quantity level A (normal). The vibrational characteristics and behaviour of electrical machinery is specified in DIN EN 60034-14. Feather key agreement for balancing "half-key" (H) is specified here based on DIN ISO 8821.

The feather key agreement type for balancing is stamped on the face of the customer-specific drive-end (DE) / non-drive end (NDE) shaft extension.

F = Balancing with full key  
(Agreement full-key)

H = Balancing with half key  
(Agreement half-key)

N = Balancing without key – Plain text required  
(without feather key agreement)

Motors up to frame size 112 have the type of balancing marked exclusively on the rating plate.

Full key balancing or balancing with full key can be supplied if order code **L68** is specified (additional charge).

Vibration quantity level	Machine installation	Limits (rms values) for max. vibration quantity of vibration distance (s), vibration speed (v) and acceleration (a) for the shaft height H								
		Shaft height H in mm 56 ≤ H ≤ 132			132 < H ≤ 280			H > 280		
		$s_{rms}$ μm	$v_{rms}$ mm/s	$a_{rms}$ mm/s <sup>2</sup>	$s_{rms}$ μm	$v_{rms}$ mm/s	$a_{rms}$ mm/s <sup>2</sup>	$s_{rms}$ μm	$v_{rms}$ mm/s	$a_{rms}$ mm/s <sup>2</sup>
A	Free suspension	25	1.6	2.5	35	2.2	3.5	45	2.8	4.4
	Rigid clamping	21	1.3	2.0	29	1.8	2.8	37	2.3	3.6
B	Free suspension	11	0.7	1.1	18	1.1	1.7	29	1.8	2.8
	Rigid clamping	–	–	–	14	0.9	1.4	24	1.5	2.4

For details, see standard DIN EN 60034-14 Sept. 2004.

#### Shaft and rotor

##### Shaft extension

60° center hole to DIN 332, Part 2 with M3 to M24 tapped hole depending on the shaft diameter (see dimension tables in the corresponding catalog parts)

Second standard shaft extension.

Order code **K16**.

Not possible for the motor version with protective cover.

The second shaft extension can transmit the full rated output via a coupling output up to frame size 315 M (please inquire about reduced transmitted power for frame sizes of 315 L and above). For motor series 1LA8 and 1LL8, the second shaft extension can transmit 50 % of the rated output with a coupling output. (Please contact your local Siemens office if higher values are required.) The full rated output is not applicable for 1LA motors, frame sizes 90 S to 112 M. These motors can only transmit the rated output of the next smaller size.

Please also inquire about the transmitted power and admissible cantilever force if belt pulleys, chains or gear pinions are used on the second shaft extension.

A second shaft extension is not available if a rotary pulse encoder and/or separately driven fan is mounted (also applicable to motor series 1PQ8). Please inquire if a brake is mounted. For motor series 1LA8 and 1LL8, the second standard shaft extension is only available on request for 2-pole motors – please specify the weight of the coupling and type of lever arm.

Balancing without key (N) is possible with order code **M37** on request (additional charge).

The vibration quantity level A is the standard version and is valid for a rated frequency up to 60 Hz.

For special requirements concerning smooth running, a low-vibration version B can be supplied (additional charge).

Vibration quantity level B.

Not possible with parallel roller bearings.

Order code **K02**

The limits stated in the table below are applicable to freely suspended motors running uncoupled and at no load as well as to rigidly installed 1LA8 motors, frame size 450.

For converter-fed operation with frequencies greater than 60 Hz, special balancing is required for compliance with the specified limit values (plain text: Max. supply frequency speed).

For further details, see the online help in SD configurator.

The non-drive end (NDE) of frame sizes 100 L to 225 M has an M8 center hole, DR form, for mounting the 1XP8 001 rotary pulse encoder or for fitting and extraction tools.

The non-drive end (NDE) of the 1LG4 and 1LG6 motors of frame sizes 180 M to 315 L, has an M16 center hole, DS form.

##### Shaft extension (DE)

Diameter mm	Thread mm
7 ... 10	DR M3
>10 ... 13	DR M4
>13 ... 16	DR M5
>16 ... 21	DR M6
>21 ... 24	DR M8
>24 ... 30	DR M10
>30 ... 38	DR M12
>38 ... 50	DS M16
>50 ... 85	DS M20
>85 ... 130	DS M24

Dimensions and tolerances for keyways and keys are designed to DIN EN 50347. The motors are always supplied with a key inserted in the shaft.

Shaft extension with standard dimensions, without featherkey way

For motor series 1LA5, 1LA6, 1LA7, 1LA8, 1LA9, 1LG4, 1LG6, 1LL8, 1LP4, 1LP5, 1LP7, 1MA6, 1MA7, 1PP4, 1PP5, 1PP7 and 1PQ8, the standard shaft extension can be ordered with standard dimensions without a featherkey way.

Order code **K42**

Standard shaft made of non-rusting steel

For motor series 1LA5, 1LA6, 1LA7, 1LP5, 1LP7, 1PP5 and 1PP7, a standard shaft made of non-rusting steel (material X20Cr13V) can be ordered. This is only possible for shaft extensions of standard dimensions. For non-standard shaft dimensions, there will be an additional charge!

Order code **M65**

Please inquire about other rust-resistant materials.

Please inquire regarding motor series 1LG4 and 1LG6.

Non-standard cylindrical shaft extension

The non-standard cylindrical shaft extension can be used on the drive end (DE) or non-drive end (NDE). The featherkey is always supplied with it.

Order code **Y55**

When motors are ordered which have a longer or shorter shaft extension as standard, the required position and length of the featherkey way must be specified in a sketch. It must be ensured that only featherkeys in accordance with DIN 6885, Form A are permitted to be used. The location of the featherkey way is in the

center of the shaft extension and, in the case of non-standard motors, 5 mm from the shaft extension. The length is defined by the manufacturer normatively.

Not valid for: Conical shafts, non-standard threaded journals, non-standard shaft tolerances, friction welded journals, extremely "thin" shafts, special geometry dimensions (e.g. square journals, etc.), hollow shafts.

For 1MJ motors with longer shaft extensions than standard, the admissible cantilever force must be reduced accordingly. This will ensure that the shaft does not sag more than with the standard shaft extension (please inquire).

For order code **Y55** and second standard shaft extension **K16** (see previous page):

- Dimensions D and DA must be less than or equal to the inner diameter of the roller bearing (see dimension tables under "Dimensions" in the relevant catalog parts)
- Dimensions E and EA must be smaller than or equal to 2 x length E (standard) of the shaft extension

A non-standard cylindrical shaft extension can be supplied for the motor series listed in the table "Admissible changes to shaft extension" below up to the specified maximum lengths and diameters as compared to the standard shaft.

It is the responsibility of the customer to ensure that the admissible cantilever forces are reduced in accordance with the non-standard shaft extension.

**Admissible changes to the shaft extension:**

Motor series	Frame size	Number of poles	Shaft extension length E in mm		Shaft extension diameter D in mm	
			Standard	Up to max.	Standard	Up to max. <sup>1)</sup>
<b>1LA6, 1LA7, 1LA9, 1MA6, 1LP7, 1PP7</b>	56	2 ... 8	20	40	9	12
	63		23	46	11	
	71		30	60	14	15
	80		40	80	19	20
	90		50	100	24	25
	100		60	120	28	30
	112					
	132		80	160	38	40
<b>1LA5, 1LA9, 1LG4, 1LG6, 1MA6, 1LP4, 1LP5, 1PP4, 1PP5</b>	160		110	220	42	45
	180	2 ... 8			48	48
	200				55	55
	225	2				60
	250	4 ... 8	140	280	60	
		2				70
	280	4 ... 8			65	
		2				75
	315	4 ... 8			75	80
		2			65	
<b>1LA8, 1PQ8</b>	315 <sup>2)</sup>	4 ... 8	170	340	80	90
		2	140	280	65	70
	355 <sup>2)</sup>	4 ... 8	170	340	85	85
		2	140	280	75	80
	400	4 ... 8	170	340	95	95
		2			80	80
	450	4 ... 8	210	420	110	115
		2	170	340	90	90
	4 ... 8	210	420	120	125	

Concentricity of shaft extension, coaxiality and linear movement in accordance with DIN 42955 Tolerance R for flange-mounting motors

The following are specified in DIN 42955 with Tolerance N (normal) and Tolerance R (reduced):

1. Concentricity tolerances for the shaft extension
2. Coaxiality tolerances for the shaft extension and flange centering
3. Linear movement tolerances for the shaft extension and flange surface

<sup>1)</sup> At admissible diameter, a step increase in shaft diameter is not possible.

The concentricity of the shaft extension, coaxiality and linear movement according to DIN 42955 Tolerance R for flange-mounting motors can be ordered using order code **K04**.

This order code can be combined for motors with deep-groove bearings of series 60.., 62.. and 63... This cannot be supplied in combination with parallel roller bearings (e.g. bearings for increased cantilever forces, order code K20), brake or encoder mounting.

Concentricity of the shaft extension can be ordered according to DIN 42955 Tolerance R for types of construction without a flange with order code **L39**.

<sup>2)</sup> For bearing design for increased cantilever forces order code **K20** a shaft diameter of 95 mm for frame size 315 and a shaft diameter of 100 mm for frame size 355 is possible for 4, 6 and 8-pole motors. See dimension drawings Page 3/65 and 3/67.

# IEC Squirrel-Cage Motors

## Introduction motors 1LA, 1LG, 1LL, 1LP, 1MA, 1MJ, 1PP, 1PQ

### General technical data

#### Bearings and lubrication

##### Bearing lifetime (nominal lifetime)

The nominal bearing lifetime is defined acc. to standardized calculation procedures (DIN ISO 281) and is reached or even exceeded for 90 % of the bearings when the motors are operated in the compliance with the data provided in the catalog.

Under average operating conditions, a lifetime ( $L_{h10}$ ) of 100,000 hours can be achieved.

Generally, the bearing lifetime is defined by the bearing size, the bearing load, the operating conditions, the speed and the grease lifetime.

##### Bearing system

The bearing lifetime of motors with horizontal type of construction is at least 40,000 hours if there is no additional axial loading at the coupling output and at least 20,000 hours with the admissible permitted loads.

This assumes that the motor is operated at 50 Hz. The nominal bearing lifetime is reduced for converter-fed operation at higher frequencies.

For the admissible vibration values measured at the bearing plate, evaluation zones A and B specified in ISO 10816 are applicable in order to achieve the calculated lifetime under continuous duty. If higher vibration speeds will occur under the operating conditions, special arrangements will be necessary (please inquire).

For standard motors applies the following:

In the basic bearing system, the floating bearing is situated at the drive end (DE) and the located bearing (axially located from frame size 160 and above) is situated at the non-drive end (NDE). On request, the located bearing can also be supplied at the drive end (DE) (Fig. 3, Page 0/64).

For ordering standard motors quote order code **K94**.

For 1LA8, 1PQ8 and 1LL8 non-standard motors applies the following:

In the basic bearing system, the floating bearing is situated at the non-drive end (NDE) and the located bearing is situated at the drive end (DE).

On request, the located bearing can also be supplied at the non-drive end (NDE).

Price on request.

The bearing system is axially preloaded with a spring element to ensure smooth running of the motor without play.

This is not the case in versions with parallel roller bearings. The bearings of these motors must always run under adequate radial force (motors must not be operated on a testbed without additional radial loads).

Motors of series 1LA6, 1LA7, 1LA9 and 1MA7 up to and including frame size 132 have a "floating" bearing arrangement (see Fig. 1, Page 0/64).

Up to frame size 132, an additional axially-secured located bearing can be supplied on the non-drive end (NDE) complete with a retaining ring (see Figure 2, Page 0/64).

Order code **L04**

For frame size 160 and above, bearings are usually axially located (see Figures 2, 4 and 5, Page 0/64).

For increased cantilever forces (e.g. belt drives), reinforced bearings can be used at the drive end (DE).

Order code **K20**

Motors 1LG4/6 in frame sizes 180 to 315, 2-pole, can be supplied with reinforced deep-groove bearings at both ends (size range 03).

Special bearings for DE and NDE, bearing size 63

Order code **K36**

A measuring nipple for SPM shock pulse measurement is mounted to check bearing vibration. The motors have 1 or 2 tapped holes per bearing plate and a measuring nipple with a protective cap. If a second tapped holes is provided, it is fitted with a sealing cap.

Order code **G50**

Bearing arrangement for increased cantilever forces on Pages 0/62 and 0/63 – admissible loading on Pages 0/67 and 0/68.

##### Insulated bearings

To prevent damage as a result of bearing currents, insulated bearings can be supplied at the non-drive end NDE from frame size 225 to 315 and are recommended for frame size 225 and above. This bearing design is also possible for 1MJ7 motors from frame size 250 to 315. In a version in combination with mounting of brake (order code G26), the insulated motor bearings are mounted on the drive end (DE).

Order code **L27**

The insulated bearing is standard for all 1LA8, 1PQ8 and 1LL8 motors which are identified for converter-fed operation.

##### Permanent lubrication

For permanent lubrication, the bearing grease lifetime is matched to the bearing lifetime. This can, however, only be achieved if the motor is operated in accordance with the catalog specifications.

In the basic version, the motors up to and including shaft height 250 have permanent lubrication.

##### Regreasing

For motors which can be re-greased at defined re-greasing intervals, the bearing lifetime can be extended and/or unfavourable factors such as temperature, mounting conditions, speed, bearing size and mechanical load can be compensated.

From a shaft height of 280 upwards, regreasing with an M10 x 1 flat greasing nipple to DIN 3404 is provided.

It is possible to regrease motors, shaft heights 100 to 250.

A lubricating nipple is optionally provided.

Order code **K40**

In the case of motors equipped with regreasing devices, information regarding greasing intervals, quantity and type of grease and any additional data is provided on the lubrication or rating plate. (Re-greasing intervals for basic version on Page 0/59).

The regreasing device cannot be mounted in combination with mounting of the brake, order Code G26.

##### Mechanical stress and grease lifetime

High speeds that exceed the rated speed with converter-fed operation and the resulting increased vibrations alter the mechanical running smoothness and the bearings are subjected to increased mechanical stress. This reduces the grease lifetime and the bearing lifetime (please inquire where applicable).

For converter-fed operation in particular, compliance with the mechanical limit speeds  $n_{adm}$  at admissible supply frequency  $f_{max}$  is essential, see catalog part 5 "Motors operating with frequency converters".

# IEC Squirrel-Cage Motors

## Introduction motors 1LA, 1LG, 1LL, 1LP, 1MA, 1MJ, 1PP, 1PQ

### General technical data

#### Grease lifetime and regreasing intervals for horizontal installation

Permanent lubrication <sup>1)</sup>				
Type series	Frame size	Type	Number of poles	Grease lifetime up to CT 40 °C <sup>2)</sup>
<b>All</b>	56 to 250		2 to 8	20000 h or 40000 h <sup>3)</sup>
Regreasing (basic version) <sup>1)</sup>				
Type series	Frame size	Type	Number of poles	Regreasing interval up to CT 40 °C <sup>2)</sup>
<b>1LA6, 1PP6</b>	100 to 160	... 10 . to ... 16 .	2 to 8	8000 h
<b>1LA5, 1LP5, 1PP5 1LA7, 1LP7, 1PP7 1LA9</b>	100 to 225	... 10 . to ... 22 .	2 to 8	8000 h
<b>1LA8.. 1PQ8..</b>	315 to 400	... 31 . to ... 40 .	2	4000 h
		... 31 . to ... 40 .	4 to 8	6000 h
	450	... 45 .	2	3000 h
<b>1LL8..</b>	315	... 45 .	4 to 8	6000 h
		... 31 .	2	4000 h
	355 to 450	... 31 .	4 to 8	8000 h / 4000 h <sup>4)</sup>
<b>1LG4, 1LP4, 1PP4 1LG6, 1PP6</b>	180 to 280	... 35 . to ... 45 .	2	4000 h
		... 35 . to ... 45 .	4 to 8	6000 h / 3000 h <sup>4)</sup>
	315	... 18 . to ... 28 .	2	4000 h
<b>1MA6</b>	100 to 200	... 31	2	3000 h
		... 31	4 to 8	6000 h
	225 to 280	... 10 . to ... 20 .	2 to 8	8000 h
		... 22 . to ... 28 .	2	4000 h
	315	... 315	4 to 8	8000 h
<b>1MA7</b>	100 to 160	... 315	2	3000 h
		... 315	4 to 8	6000 h
<b>1MJ6, 1MJ7</b>	180 to 200	... 10 . to ... 16 .	2 to 8	8000 h
		... 18 . to ... 20 .	2 to 8	8000 h
	225 to 280	... 22 . to ... 28 .	2	4000 h
		... 22 . to ... 28 .	4 to 8	8000 h
315	... 315	2	4000 h	
		... 315	4 to 8	8000 h

<sup>1)</sup> For special uses and special greases, please inquire about grease lifetime and regreasing intervals.

<sup>2)</sup> If the coolant temperature is increased by 10 K, the grease lifetime and regreasing interval are halved.

<sup>3)</sup> 40 000 h applies for horizontally installed motors with coupling output without additional axial loads.

<sup>4)</sup> Regreasing interval for IM V1 type of construction.

# IEC Squirrel-Cage Motors

## Introduction motors 1LA, 1LG, 1LL, 1LP, 1MA, 1MJ, 1PP, 1PQ

### General technical data

#### Bearing selection table for 1LA5, 1LA6, 1LA7, 1LA9, 1LG, 1LP, 1MA and 1PP motors – basic version

The bearing selection tables are only intended for planning purposes. Authoritative information on the actual type of bearings fitted in motors already supplied can be obtained by the factory by quoting the serial number or can be read from the lubricating plate on 1LA8 motors.

When deep-groove ball bearings with sideplates are used, the side plate is on the inside. For located bearings on drive end DE for 1LA5, 1LA7, 1LA9, 1MA6 and 1MA7 motors, see special version in Figure 3 (Page 0/64).

For motors frame size	Type	Number of poles	Drive end (DE) bearing		Non-drive end NDE bearing		Figures on Pages 0/64 and 0/65	
			Horizontal type of construction	Vertical type of construction	Horizontal type of construction	Vertical type of construction		
<b>1LA5 . . . , 1LA6 . . . , 1LA7 . . . , 1LA9 . . . , 1LP5 . . . , 1LP7 . . . , 1MA6 . . . , 1MA7 . . . , 1PP5 . . . , 1PP7 . . .</b>								
56 M	. . . . <b>05</b> .	2 to 8	6201 2ZC3	6201 2ZC3	6201 2ZC3	6201 2ZC3	<b>Fig. 1</b>	
63 M	. . . . <b>06</b> .	2 to 8	6201 2ZC3	6201 2ZC3	6201 2ZC3	6201 2ZC3		
71 M	. . . . <b>07</b> .	2 to 8	6202 2ZC3	6202 2ZC3	6202 2ZC3	6202 2ZC3		
80 M	. . . . <b>08</b> .	2 to 8	6004 2ZC3	6004 2ZC3	6004 2ZC3	6004 2ZC3		
90 S/L	. . . . <b>09</b> .	2 to 8	6205 2ZC3	6205 2ZC3	6004 2ZC3	6004 2ZC3		
100 L	. . . . <b>10</b> .	2 to 8	6206 2ZC3 <sup>1)</sup>	6206 2ZC3 <sup>1)</sup>	6205 2ZC3 <sup>1)</sup>	6205 2ZC3 <sup>1)</sup>		
112 M	. . . . <b>11</b> .	2 to 8	6206 2ZC3 <sup>1)</sup>	6206 2ZC3 <sup>1)</sup>	6205 2ZC3 <sup>1)</sup>	6205 2ZC3 <sup>1)</sup>		
132 S/M	. . . . <b>13</b> .	2 to 8	6208 2ZC3 <sup>1)</sup>	6208 2ZC3 <sup>1)</sup>	6208 2ZC3 <sup>1)</sup>	6208 2ZC3 <sup>1)</sup>		
160 M/L	. . . . <b>16</b> .	2 to 8	6209 2ZC3 <sup>1)</sup>	6209 2ZC3 <sup>1)</sup>	6209 2ZC3 <sup>1)</sup>	6209 2ZC3 <sup>1)</sup>		<b>Fig. 2</b>
180 M/L	. . . . <b>18</b> .	2 to 8	6210 ZC3 <sup>2)</sup>	6210 ZC3 <sup>2)</sup>	6210 ZC3 <sup>2)</sup>	6210 ZC3 <sup>2)</sup>		<b>Fig. 4</b>
200 L	. . . . <b>20</b> .	2 to 8	6212 ZC3 <sup>2)</sup>	6212 ZC3 <sup>2)</sup>	6212 ZC3 <sup>2)</sup>	6212 ZC3 <sup>2)</sup>	<b>Fig. 4</b>	
225 S/M	. . . . <b>22</b> .	2 to 8	6213 ZC3 <sup>2)</sup>	6213 ZC3 <sup>2)</sup>	6212 ZC3 <sup>2)5)</sup>	6212 ZC3 <sup>2)5)</sup>		
250 M	. . . . <b>25</b> .	2 to 8	6215 ZC3 <sup>2)</sup>	6215 ZC3 <sup>2)</sup>	6215 ZC3 <sup>2)</sup>	6215 ZC3 <sup>2)</sup>		
280 S/M	. . . . <b>28</b> .	2 4 to 8	6216 C3 6317 C3	6216 C3 6317 C3	6216 C3 6317 C3	6216 C3 6317 C3	<b>Fig. 5</b>	
315 S/M	. . . . <b>310</b> . . . . <b>313</b>	2 4 to 8	6217 C3 6319 C3	6217 C3 6319 C3	6217 C3 6319 C3	6217 C3 6319 C3		
315 L	. . . . <b>316</b> . . . . <b>317</b> . . . . <b>318</b>	2 4 to 8	6217 C3 6319 C3	6217 C3 6319 C3	6217 C3 6319 C3	7217 BEP 6319 C3		
<b>1LG4 . . . , 1LG6 . . . , 1LP4 . . . , 1PP4 . . . , 1PP6 . . .</b>								
180 M/L	. . . . <b>18</b> .	2 to 8	6210 ZC3 <sup>4)</sup>	6210 ZC3 <sup>4)</sup>	6210 ZC3 <sup>4)</sup>	6210 ZC3 <sup>4)</sup>	<b>Fig. 4</b>	
200 L	. . . . <b>20</b> .	2 to 8	6212 ZC3 <sup>4)</sup>	6212 ZC3 <sup>4)</sup>	6212 ZC3 <sup>4)</sup>	6212 ZC3 <sup>4)</sup>		
225 S/M	. . . . <b>22</b> .	2 to 8	6213 ZC3 <sup>4)</sup>	6213 ZC3 <sup>4)</sup>	6213 ZC3 <sup>4)</sup>	6213 ZC3 <sup>4)</sup>		
250 M	. . . . <b>25</b> .	2 to 8	6215 ZC3 <sup>4)</sup>	6215 ZC3 <sup>4)</sup>	6215 ZC3 <sup>4)</sup>	6215 ZC3 <sup>4)</sup>		
280 S/M	. . . . <b>28</b> .	2 4 to 8	6217 C3 6317 C3	6217 C3 6317 C3	6217 C3 6317 C3	6217 C3 6317 C3	<b>Fig. 5</b>	
315 S/M	. . . . <b>310</b> . . . . <b>313</b>	2 4 to 8	6219 C3 6319 C3	6219 C3 6319 C3	6219 C3 6319 C3	6219 C3 6319 C3		
315 L	. . . . <b>316</b> . . . . <b>317</b> . . . . <b>318</b>	2 4 to 8	6219 C3 6319 C3	6219 C3 <sup>3)</sup> 6319 C3	6219 C3 6319 C3	7219 BEP <sup>3)</sup> 6319 C3		

<sup>1)</sup> Deep-groove bearings are used for regreasable versions (order code **K40**).

<sup>2)</sup> Deep-groove bearings are not used for regreasable versions (order code **K40**) of 1MA6 motors of frame sizes 180 M to 250 M.

<sup>3)</sup> Only at 50 Hz.

<sup>4)</sup> Deep-groove bearings are not used for regreasable versions (order code **K40**).

<sup>5)</sup> For 1MA6 motors frame size 225 S/M bearing 6213 ZC3 at the non-drive end NDE (BS).

# IEC Squirrel-Cage Motors

## Introduction motors 1LA, 1LG, 1LL, 1LP, 1MA, 1MJ, 1PP, 1PQ

### General technical data

0

Bearing selection table for 1LA8, 1PQ8 and 1LL8 motors – basic version

For motors frame size	Type	Number of poles	Drive end (DE) bearing		Non-drive end NDE bearing		Figures on Pages 0/64 and 0/65	
			Horizontal type of construction	Vertical type of construction	Horizontal type of construction	Vertical type of construction		
<b>1LA8 . . . , 1PQ8 . . .</b>								
315	. . . . <b>31</b> .	2	6218 C3	6218 C3	6218 C3	6218 C3	<b>Fig. 6 and Fig. 7</b>	
		4 to 8	6218 C3	6218 C3	6218 C3	6218 C3		
355	. . . . <b>35</b> .	2	6218 C3	7218 B + 6218 C3	6218 C3	6218 C3		
		4 to 8	6220 C3	7220 B + 6220 C3	6220 C3	6220 C3		
400	. . . . <b>40</b> .	2	6218 C3	7218 B + 6218 C3	6218 C3	6218 C3		
		4 to 8	6224 C3	7224 B + 6224 C3	6224 C3	6224 C3		
450	. . . . <b>45</b> .	2	6220 C3	7220 B + 6220 C3	6220 C3	6220 C3		
		4 to 8	6226 C3	7226 B + 6226 C3	6226 C3	6226 C3		
<b>1LL8 . . .</b>								
315	. . . . <b>31</b> .	2	6218 C3	6218 C3	6218 C3	6218 C3		<b>No figure</b>
		4 to 8	6220 C3	7220 B + 6220 C3	6218 C3	6218 C3		
355	. . . . <b>35</b> .	2	6218 C3	6218 C3	6218 C3	6218 C3		
		4 to 8	6224 C3	7224 B + 6224 C3	6220 C3	6220 C3		
400	. . . . <b>40</b> .	2	6218 C3	6218 C3	6218 C3	6218 C3		
		4 to 8	6226 C3	7226 B + 6226 C3	6224 C3	6224 C3		
450	. . . . <b>45</b> .	2	6220 C3	6220 C3	6220 C3	6220 C3		
		4 to 8	6228 C3	7228 B + 6226 C3	6228 C3	6226 C3		

1LA8, 1PQ8 and 1LL8 non-standard motors are transported horizontally. They can be transported vertically at an additional charge on request.

Bearing selection table for 1MJ motors – basic version

For motors frame size	Type	Number of poles	Drive end (DE) bearing		Non-drive end NDE bearing		Figure on Page 0/65
			Horizontal type of construction	Vertical type of construction	Horizontal type of construction	Vertical type of construction	
71 M	<b>1MJ6 07</b> .	2 to 8	6202 ZC3	6202 ZC3	6202 ZC3	6202 ZC3	<b>Fig. 8</b>
80 M	<b>1MJ6 08</b> .	2 to 8	6004 ZC3	6004 ZC3	6004 ZC3	6004 ZC3	
90 S/L	<b>1MJ6 09</b> .	2 to 8	6205 C3	6205 C3	6205 C3	6205 C3	<b>Fig. 9</b>
100 L	<b>1MJ6 10</b> .	2 to 8	6206 C3	6206 C3	6206 C3	6206 C3	
112 M	<b>1MJ6 11</b> .	2 to 8	6306 C3	6306 C3	6306 C3	6306 C3	
132 S/M	<b>1MJ6 13</b> .	2 to 8	6308 C3	6308 C3	6308 C3	6308 C3	<b>Fig. 10</b>
160 M/L	<b>1MJ6 16</b> .	2 to 8	6309 C3	6309 C3	6309 C3	6309 C3	
180 M/L	<b>1MJ6 18</b> .	2 to 8	6210 C3	6210 C3	6210 C3	6210 C3	<b>Fig. 11</b>
200 L	<b>1MJ6 20</b> .	2 to 8	6212 C3	6212 C3	6212 C3	6212 C3	
225 S/M	<b>1MJ7 22</b> .	2 to 8	6213 C3	6213 C3	6213 C3	6213 C3	
250 M	<b>1MJ7 25</b> .	2 to 8	6215 C3	6215 C3	6215 C3	6215 C3	
280 S/M	<b>1MJ7 28</b> .	2 to 8	NU 216	NU 216	6216 C3	6216 C3	<b>Fig. 12</b>
315 S/M	<b>1MJ7 31</b> .	2	NU 217 <sup>1)</sup>	NU 217 <sup>1)</sup>	6217 C3	6217 C3	
		4 to 8	NU 218 <sup>2)</sup>	NU 218 <sup>2)</sup>	6218 C3	6218 C3	

<sup>1)</sup> Special version with deep groove bearing 6216 C3 on request. Recommended for coupling output or low cantilever forces.

<sup>2)</sup> Special version with deep groove bearing 6217 C3 on request. Recommended for coupling output or low cantilever forces.

# IEC Squirrel-Cage Motors

## Introduction motors 1LA, 1LG, 1LL, 1LP, 1MA, 1MJ, 1PP, 1PQ

### General technical data

0

Bearing selection table for 1LA5, 1LA6, 1LA7, 1LA9, 1LG, 1LP, 1MA and 1PP motors – Bearings for increased cantilever forces – Order code **K20**

Please inquire about noise and vibration data.

For NU bearings (parallel roller bearings), in contrast to standard bearings, a minimum cantilever force is required. Parallel roller bearings are not suitable for coupling output.

The bearing selection tables are only intended for planning purposes. Authoritative information on the actual type of bearings fitted in motors already supplied can be obtained by the factory

by quoting the serial number or can be read from the lubricating plate on 1LA8 motors.

When deep-groove ball bearings with sideplates are used, the side plate is on the inside.

1MJ8 motors at 60 Hz on request.

For motors frame size	Type	Number of poles	Drive end (DE) bearing		Non-drive end NDE bearing		Figure on Page 0/64	
			Horizontal type of construction	Vertical type of construction	Horizontal type of construction	Vertical type of construction		
<b>1LA5 . . . , 1LA6 . . . , 1LA7 . . . , 1LA9 . . . , 1LP5 . . . , 1LP7 . . . , 1MA6 . . . , 1MA7 . . . , 1PP5 . . . , 1PP7 . . .</b>								
100 L	. . . . <b>10</b> .	2 to 8	6306 ZC3	6306 ZC3	6205 2ZC3 <sup>1)</sup>	6205 2ZC3 <sup>1)</sup>	<b>No figure</b>	
112 M	. . . . <b>11</b> .	2 to 8	6306 ZC3	6306 ZC3	6205 2ZC3 <sup>1)</sup>	6205 2ZC3 <sup>1)</sup>		
132 S/M	. . . . <b>13</b> .	2 to 8	6308 ZC3	6308 ZC3	6208 2ZC3 <sup>1)</sup>	6208 2ZC3 <sup>1)</sup>		
160 M/L	. . . . <b>16</b> .	2 to 8	6309 ZC3	6309 ZC3	6209 2ZC3 <sup>1)</sup>	6209 2ZC3 <sup>1)</sup>		
180 M/L	. . . . <b>18</b> .	2 to 8	6310 ZC3	6310 ZC3	6210 ZC3	6210 ZC3		
200 L	. . . . <b>20</b> .	2 to 8	6312 ZC3	6312 ZC3	6212 ZC3	6212 ZC3		
225 S/M	. . . . <b>22</b> .	2 to 8	NU 213 E <sup>2)3)</sup>	NU 213 E <sup>2)3)</sup>	6212 ZC3 <sup>4)</sup>	6212 ZC3 <sup>4)</sup>		
250 M	. . . . <b>25</b> .	2 to 8	NU 215 E <sup>2)</sup>	NU 215 E <sup>2)</sup>	6215 ZC3	6215 ZC3		
280 S/M	. . . . <b>28</b> .	2 4 to 8	NU 216 E NU 317 E	NU 216 E NU 317 E	6216 C3 6317 C3	6216 C3 6317 C3		
315 S/M	. . . . <b>310</b> . . . . <b>313</b>	2 4 to 8	NU 217 E NU 319 E	NU 217 E NU 319 E	6217 C3 6319 C3	6217 C3 6319 C3		
315 L	. . . . <b>316</b> . . . . <b>317</b> . . . . <b>318</b>	2 4 to 8	NU 217 E NU 319 E	– NU 319 E	6217 C3 6319 C3	– 6319 C3		
<b>1LG4 . . . , 1LG6 . . . , 1LP4 . . . , 1PP4 . . .</b>								
180 M/L	. . . . <b>18</b> .	2 to 8	NU 210	NU 210	6210 C3	6210 C3		<b>Fig. 4</b>
200 L	. . . . <b>20</b> .	2 to 8	NU 212	NU 212	6212 C3	6212 C3		
225 S/M	. . . . <b>22</b> .	2 to 8	NU 213	NU 213	6213 C3	6213 C3		
250 M	. . . . <b>25</b> .	2 to 8	NU 215	NU 215	6215 C3	6215 C3		
280 S/M	. . . . <b>28</b> .	2 4 to 8	NU 217 NU 317	NU 217 NU 317	6217 C3 6317 C3	6217 C3 6317 C3	<b>Fig. 5</b>	
315 S/M	. . . . <b>310</b> . . . . <b>313</b>	2 4 to 8	NU 219 <sup>5)</sup> NU 319	NU 219 <sup>5)</sup> NU 319	6219 C3 6319 C3	6219 C3 6319 C3		
315 L	. . . . <b>316</b> . . . . <b>317</b> . . . . <b>318</b>	2 4 to 8	NU 219 <sup>5)</sup> NU 319	NU 219 <sup>5)</sup> NU 319	6219 C3 6319 C3	6219 C3 6319 C3		

<sup>1)</sup> Bearings with a side plate are used for regreasable versions (order code **K40**).

<sup>2)</sup> Deep-groove bearings of size range 03 are also possible (order code **K36**).

<sup>3)</sup> For 1LA5 motors frame size 225 S/M bearing 6313 ZC3 at the drive end.

<sup>4)</sup> For 1MA6 motors frame size 225 S/M bearing 6213 ZC3 at the non-drive end.

<sup>5)</sup> Only at 50 Hz.



# IEC Squirrel-Cage Motors

## Introduction motors 1LA, 1LG, 1LL, 1LP, 1MA, 1MJ, 1PP, 1PQ

### General technical data

Bearing selection table for 1LA8, 1PQ8 and 1LL8 motors – bearings for increased cantilever forces – Order code **K20**

For motors frame size	Type	Number of poles	Drive end (DE) bearing		Non-drive end NDE bearing		
			Horizontal type of construction	Vertical type of construction	Horizontal type of construction	Vertical type of construction	
<b>1LA8 . . . , 1PQ8 . . .</b>							
315	. . . . <b>31</b> .	4 to 8	NU 320 E	On request	6218 C3	On request	<b>No figure</b>
355	. . . . <b>35</b> .	4 to 8	NU 322 E	On request	6220 C3	On request	

Please inquire about noise and vibration data. For NU bearings, in contrast to standard bearings, a minimum cantilever force is required. The bearing selection tables are only intended for planning purposes. Binding statements about the bearings for motors which have already been shipped can be requested. Please specify the serial number.

The motors are transported horizontally; they can be transported vertically at additional cost on request. Reinforced bearings are available for frame sizes 400 and 450 as well as IM V1 types of construction as well as for 1LL8 motors on request. Please specify cantilever force and dimension x. Reinforced bearings cannot be supplied for 2-pole motors.

Bearing selection table for 1MJ6 and 1MJ7 motors – Bearings for increased cantilever forces – Order code **K20**

For motors frame size	Type	Number of poles	Drive end (DE) bearing		Non-drive end NDE bearing		
			Horizontal type of construction	Vertical type of construction	Horizontal type of construction	Vertical type of construction	
<b>1MJ6 . . .</b>							
180 M/L	. . . . <b>18</b> .	2 to 8	NU 210	NU 210	6210 ZC3	6210 ZC3	<b>No figure</b>
200 L	. . . . <b>20</b> .	2 to 8	NU 212	NU 212	6212 ZC3	6212 ZC3	
<b>1MJ7 . . .</b>							
225 M/L	. . . . <b>22</b> .	2 to 8	NU 213	NU 213	6213 C3	6213 C3	<b>No figure</b>
250 M	. . . . <b>25</b> .	2 to 8	NU 215	NU 215	6215 C3	6215 C3	

Bearing selection table for 1LG4, 1LG6, 1LP4 and 1PP4 motors – Deep-groove bearings reinforced at both ends – Order code **K36**

For motors frame size	Type	Number of poles	Drive end (DE) bearing		Non-drive end NDE bearing		Figure on Page 0/64
			Horizontal type of construction	Vertical type of construction	Horizontal type of construction	Vertical type of construction	
<b>1LG4 . . . , 1LG6 . . . , 1LP4 . . . , 1PP4 . . .</b>							
180 M/L	. . . . <b>18</b> .	2 to 8	6310 ZC3 <sup>1)</sup>	6310 ZC3 <sup>1)</sup>	6310 ZC3 <sup>1)</sup>	6310 ZC3 <sup>1)</sup>	<b>Fig. 4</b>
200 L	. . . . <b>20</b> .	2 to 8	6312 ZC3 <sup>1)</sup>	6312 ZC3 <sup>1)</sup>	6312 ZC3 <sup>1)</sup>	6312 ZC3 <sup>1)</sup>	
225 S/M	. . . . <b>22</b> .	2 to 8	6313 ZC3 <sup>1)</sup>	6313 ZC3 <sup>1)</sup>	6313 ZC3 <sup>1)</sup>	6313 ZC3 <sup>1)</sup>	
250 M	. . . . <b>25</b> .	2 to 8	6315 ZC3 <sup>1)</sup>	6315 ZC3 <sup>1)</sup>	6315 ZC3 <sup>1)</sup>	6315 ZC3 <sup>1)</sup>	
280 S/M	. . . . <b>28</b> .	2 4 to 8	6317 C3 6317 C3 <sup>2)</sup>	6317 C3 6317 C3 <sup>2)</sup>	6317 C3 6317 C3 <sup>2)</sup>	6317 C3 6317 C3 <sup>2)</sup>	<b>Fig. 5</b>
315 S/M/L	. . . . <b>31</b> .	2 4 to 8	6316 C3 6319 C3 <sup>2)</sup>	6316 C3 6319 C3 <sup>2)</sup>	6316 C3 6319 C3 <sup>2)</sup>	6316 C3 6319 C3 <sup>2)</sup>	

<sup>1)</sup> Deep-groove bearings are not used for regreasable versions (order code **K40**).

<sup>2)</sup> As for basic version.

# IEC Squirrel-Cage Motors

## Introduction motors 1LA, 1LG, 1LL, 1LP, 1MA, 1MJ, 1PP, 1PQ

### General technical data

#### Diagrams of bearings

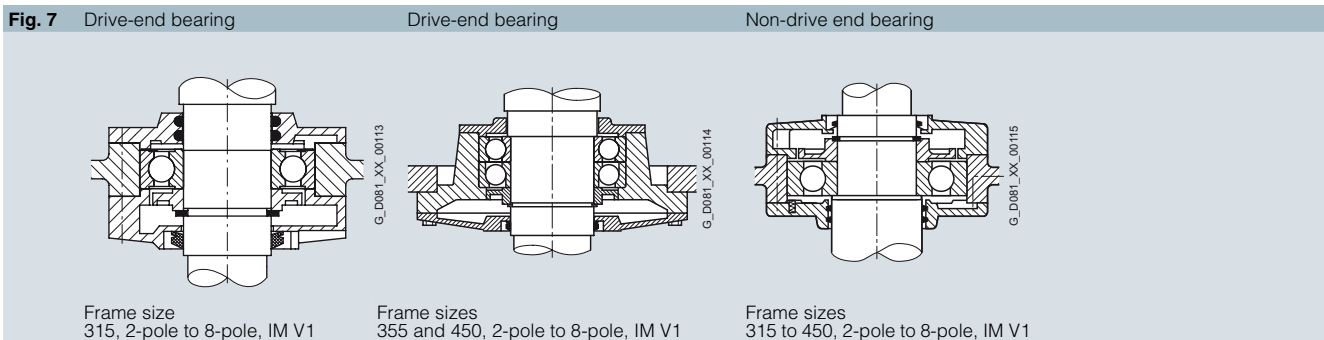
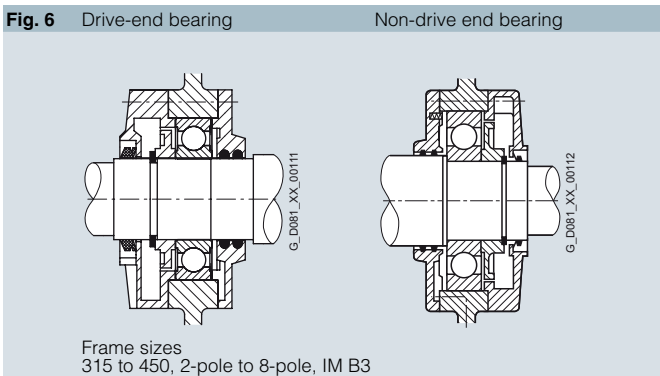
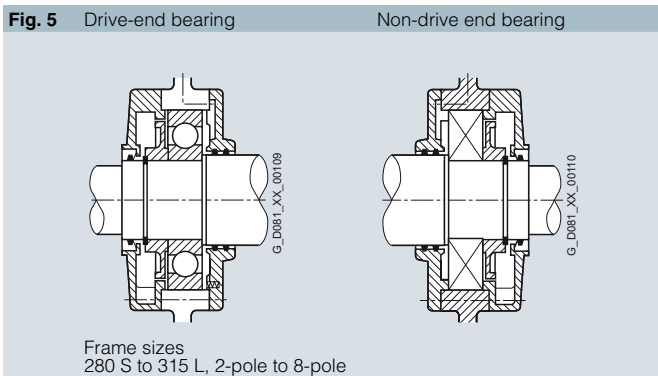
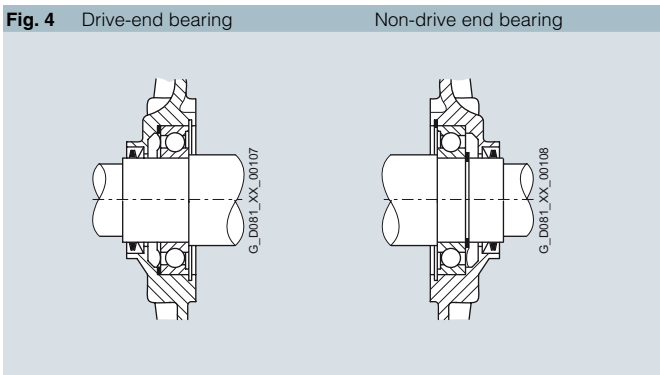
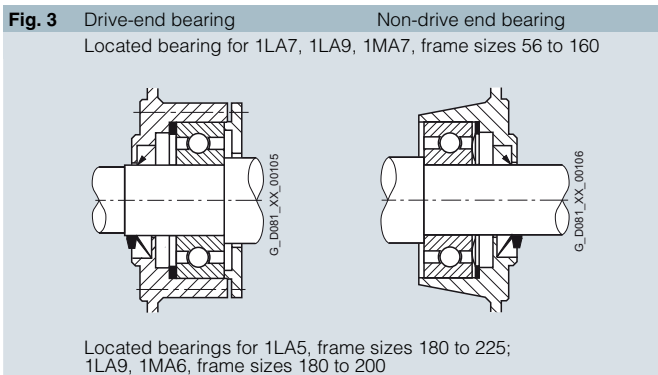
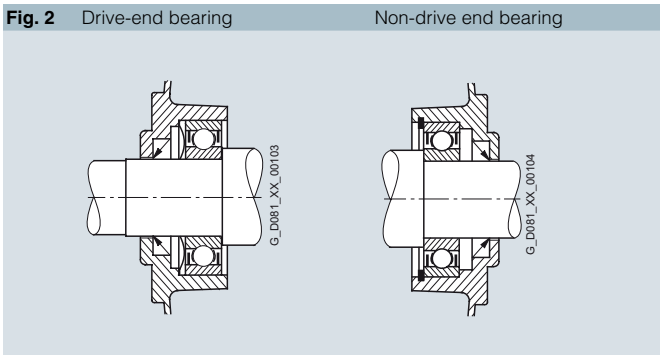
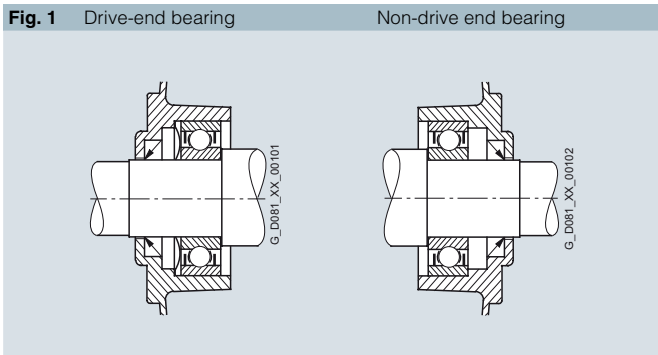

# IEC Squirrel-Cage Motors

## Introduction motors 1LA, 1LG, 1LL, 1LP, 1MA, 1MJ, 1PP, 1PQ

### General technical data

0

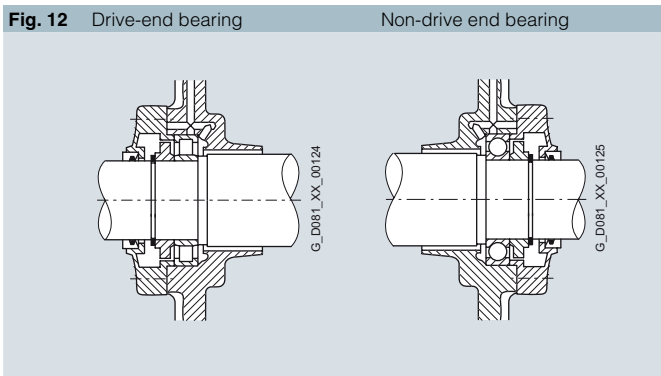
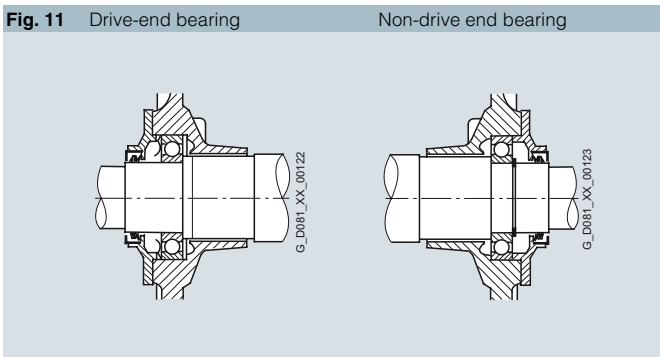
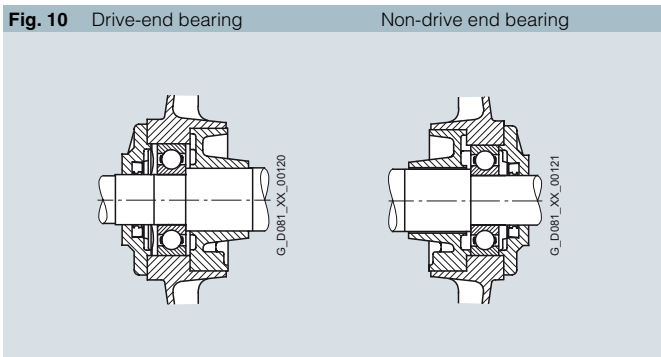
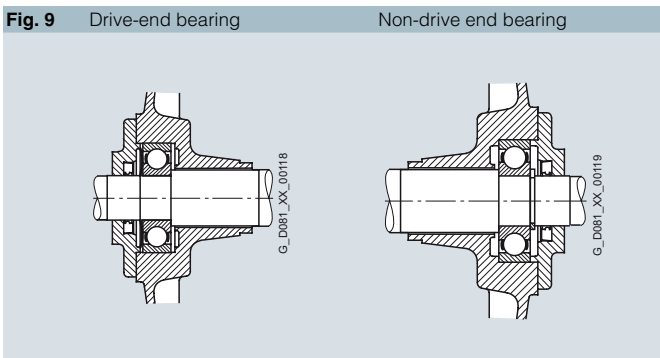
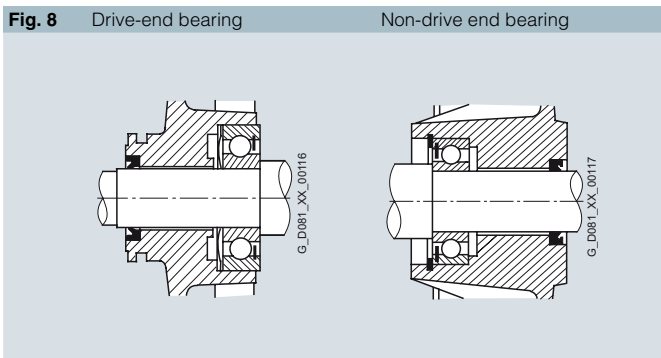

# IEC Squirrel-Cage Motors

## Introduction motors 1LA, 1LG, 1LL, 1LP, 1MA, 1MJ, 1PP, 1PQ

### General technical data

#### Admissible cantilever forces

#### Admissible cantilever forces, basic version

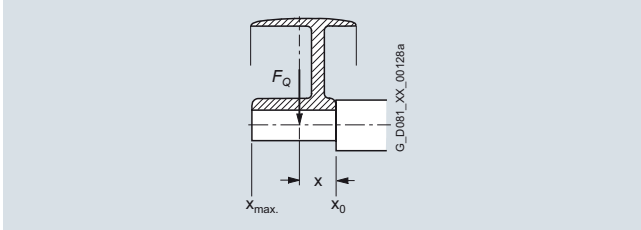

In order to calculate the admissible cantilever forces for a radial load, the line of force (i.e. the centerline of the pulley) of the cantilever force  $F_Q$  (N) must lie within the free shaft extension (dimension  $x$ ).

Dimension  $x$  [mm] is the distance between the point of application of force  $F_Q$  and the shaft shoulder. Dimension  $x_{max}$  corresponds to the length of the shaft extension.

Total cantilever force  $F_Q = c \cdot F_u$

The pre-tension factor  $c$  is a value gained from experience from the belt manufacturer. The following approximate value can be assumed:

For normal flat leather belts with an idler pulley  $c = 2$ ;  
 for V-belts  $c = 2$  to 2.5;  
 for special synthetic belts (depending on the type and load)  $c = 2$  to 2.5.

The circumferential force  $F_u$  (N) is calculated using the following equation

$$F_u = 2 \cdot 10^7 \cdot \frac{P}{n \cdot D}$$

$F_u$  circumferential force in N  
 $P$  rated motor power (transmitted power) in kW  
 $n$  rated motor speed  
 $D$  pulley diameter in mm

The pulleys are standardized acc. to DIN 2211, Sheet 3.

The admissible cantilever forces at 60 Hz are approx. 80 % of the 50 Hz values (please inquire).

#### Admissible cantilever forces for the basic 50 Hz version

Valid are:  $x_0$  values for  $x = 0$  and  $x_{max}$  values for  $x = l$  ( $l$  = shaft extension)

For motors	Admissible cantilever force for $x_0$	Admissible cantilever force for $x_{max}$ .					
		Type	Type				
Frame size	Number of poles	N	N	N	N	N	N
		1LG4	1MA6	1MJ6	1LG4	1MA6	1MJ6
		1LG6	1MJ7	1LG6	1MA6	1MJ7	1MJ7
250 M	2	3190	3650	3650	2530	2950	2950
	4	4000	4400	4400	3350	3600	3600
	6	4700	5350	5350	3900	4350	4350
	8	5200	5700	5700	4400	4700	4700
280 S 280 M	2	4000	3350	8100	3250	2800	6700
	4	8400	8400	9700	7000	7200	8050
	6	9700	10000	11700	8100	8900	9700
	8	10750	11000	12800	9000	9850	10600
315 S 315 M	2	4750	3950	9000	3890	3350	7600
	4	9100	9900	13100	7300	8100	10800
	6	10700	12100	15600	8700	9900	12800
	8	11600	13300	16900	9600	10900	13900
315 L	2	4000	3100	8800	3280	2700	7600
	4	8400	8800	24000	7500	7450	12000
	6	9700	11400	25000	9100	9600	12000
	8	11100	12500	26000	10200	10500	12000

#### Admissible cantilever forces for the basic 50 Hz version

Valid are:  $x_0$  values for  $x = 0$  and  $x_{max}$  values for  $x = l$  ( $l$  = shaft extension)

For motors	Admissible cantilever force for $x_0$	Admissible cantilever force for $x_{max}$ .					
		Type	Type				
Frame size	Number of poles	N	N	N	N	N	N
		1LA5	1LG4	1MJ6	1LA5	1LG4	1MJ6
		1LA7	1LG6	1MJ7	1LA7	1LG6	1MJ7
		1LA9	1LP4		1LA9	1LP4	
		1MA6	1PP4		1MA6	1PP4	
		1MA7	1PP6		1MA7	1PP6	
		1LA6			1LA6		
		1LP5			1LP5		
		1LP7			1LP7		
		1PP5			1PP5		
		1PP7			1PP7		
56 M	2	270	-	-	240	-	-
	4	350	-	-	305	-	-
	6	415	-	-	360	-	-
63 M	2	270	-	-	240	-	-
	4	350	-	-	305	-	-
	6	415	-	-	360	-	-
71 M	2	415	-	260	355	-	260
	4	530	-	260	450	-	260
	6	630	-	260	535	-	260
	8	690	-	-	585	-	-
80 M	2	485	-	485	400	-	400
	4	625	-	560	515	-	515
	6	735	-	560	605	-	560
	8	815	-	-	675	-	-
90 S 90 L	2	725	-	725	605	-	605
	4	920	-	920	775	-	775
	6	1090	-	1090	910	-	910
	8	1230	-	1230	1030	-	1030
100 L	2	1030	-	1030	840	-	840
	4	1310	-	1310	1060	-	1060
	6	1550	-	1550	1250	-	1250
	8	1720	-	1720	1400	-	1400
112 M	2	1010	-	1680	830	-	1490
	4	1270	-	1960	1040	-	1580
	6	1520	-	2140	1240	-	1720
	8	1690	-	2450	1380	-	1950
132 S 132 M	2	1490	-	2250	1180	-	1820
	4	1940	-	2720	1530	-	2170
	6	2260	-	3100	1780	-	2420
	8	2500	-	3400	1980	-	2700
160 M 160 L	2	1540	-	2800	1210	-	2250
	4	2040	-	3330	1590	-	2600
	6	2330	-	3750	1820	-	2900
	8	2660	-	3750	2080	-	2900
180 M 180 L	2	2000	1780	2000	1550	1410	1550
	4	2350	2240	2350	1950	1820	1950
	6	2800	2550	2800	2250	2120	2250
	8	3050	2860	3050	2500	2330	2500
200 L	2	2550	2380	2550	2100	1930	2100
	4	3350	3050	3350	2750	2530	2750
	6	3900	3500	3900	3200	2930	3200
	8	4150	3800	4150	3450	3210	3450
225 S 225 M	2	3050	2820	3050	2550	2290	2550
	4	3750	3500	3750	2950	2760	2950
	6	4550	4050	4550	3600	3240	3600
	8	4850	4500	4850	3900	3500	3900

Table continues overleaf

# IEC Squirrel-Cage Motors

## Introduction motors 1LA, 1LG, 1LL, 1LP, 1MA, 1MJ, 1PP, 1PQ

### General technical data

#### Admissible cantilever forces for the basic 50 Hz version

Valid are:  $x_0$  values for  $x = 0$  and  $x_{max}$  values for  $x = l$  ( $l$  = shaft extension)

For motors	Admissible cantilever force for $x_0$		Admissible cantilever force for $x_{max}$	
Frame size	Number of poles	Type	Type	Type
		N	N	N
		<b>1LA8, 1PQ8<sup>1)</sup></b>		<b>1LA8, 1PQ8<sup>1)</sup></b>
315 ... 450	2 ... 8	See diagrams Page 0/69	See diagrams Page 0/69	See diagrams Page 0/69

For 1LA8 motors in horizontal type of construction, the admissible cantilever forces are specified with regard to the axial forces.

It should be observed that for types of construction IM B6, IM B7, IM B8, IM V5 and IM V6 the belt tension is only permitted to act parallel to the mounting plane or towards the mounting plane and the feet must be supported. Both feet must be secured for foot-mounting types of construction.

Refer to Pages 0/67 to 0/68 if the cantilever forces are higher than those listed above.

#### Bearing design for increased cantilever forces

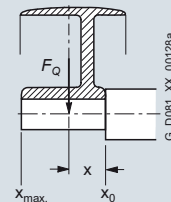

#### Admissible cantilever forces at 50 Hz for 1LA, 1MA, 1MJ, 1LP and 1PP motors

##### Deep-groove ball bearings at the drive end (DE) – Order code K20

For motors	Frame size	Type	Number of poles	Admissible cantilever force $F_Q$	
				at $x_0$	at $x_{max}$
				N	N
				<b>1LA5 ... , 1LA6 ... , 1LA7 ... , 1LA9 ... , 1MA6 ... , 1MA7 ... , 1MJ6 ... , 1MJ7 ... , 1LP5 ... , 1LP7 ... , 1PP5 ... , 1PP7 ...</b>	
100	.... 10 .	2	4	1680	1490
		4	6	1960	1580
		6	8	2140	1720
		8		2450	1950
112	.... 113	2	4	1680	1490
		4	6	1960	1580
		6	8	2140	1720
		8		2450	1950
132	.... 13 .	2	4	2250	1820
		4	6	2720	2170
		6	8	3100	2420
		8		3400	2700
160	.... 16 .	2	4	2800	2250
		4	6	3330	2600
		6	8	3750	2900
		8		3750	2900
180	.... 18 .	2	4	3700	3000
		4	6	4450	3600
		6	8	5100	4150
		8		5550	4500
200	.... 20 .	2	4	5200	4300
		4	6	6450	5350
		6	8	7300	6100
		8		7900	6550
225	<b>1LA522 .</b>	2	4	5200	4300
	<b>1LP5 ...</b>	4	6	6450	5350
	<b>1PP5 ...</b>	6	8	7300	6100
		8		7900	6550

<sup>1)</sup> Data for 1LL8 is available on request.

# IEC Squirrel-Cage Motors

## Introduction motors 1LA, 1LG, 1LL, 1LP, 1MA, 1MJ, 1PP, 1PQ

### General technical data

#### Admissible cantilever forces at 50 Hz for 1LG motors

##### Parallel roller bearings at the drive end (DE) – Order code K20

Valid are:  $x_0$  values for  $x = 0$  and  $x_{max}$  values for  $x = l$  ( $l$  = shaft extension)

Frame size	Type	Number of poles	Admissible cantilever force $F_Q$	
			at $x_0$	at $x_{max}$
			N	N
<b>1LG4 ... , 1LG6 ... , 1LP4 ... , 1PP4 ...</b>				
180 M, 180 L	.... 18 .	2	4550	3600
		4	5650	4050
		6	6350	4050
		8	6950	4050
200 L	.... 20 .	2	6600	5350
		4	8200	6850
		6	9300	6300
		8	10100	7400
225 S, 225 M	.... 22 .	2	7500	6250
		4	9150	7200
		6	10400	7400
		8	11300	7350
250 M	.... 25 .	2	9100	7300
		4	11300	9300
		6	12800	10500
		8	14100	10500
280 S <sup>1)</sup> , 280 M <sup>1)</sup>	.... 28 .	2	11400	9350
315 S <sup>1)</sup> , 315 M <sup>1)</sup>	.... 310 .... 313	2	14700	12300
315 L <sup>1)</sup>	.... 316 .... 317	2	14600	12700

#### Admissible cantilever forces at 50 Hz for 1LG motors

##### Deep-groove bearings reinforced at both ends DE/NDE – Order code K36

Valid are:  $x_0$  values for  $x = 0$  and  $x_{max}$  values for  $x = l$  ( $l$  = shaft extension)

Frame size	Type	Number of poles	Admissible cantilever force $F_Q$	
			at $x_0$	at $x_{max}$
			N	N
<b>1LG4 ... 1LG6 ...</b>				
180 M, 180 L	.... 18 .	2	3280	2600
		4	4150	3430
		6	4750	3950
		8	5250	4050
200 L	.... 20 .	2	4350	3500
		4	5550	4550
		6	6350	5350
		8	7000	5900
225 S, 225 M	.... 22 .	2	4850	3950
		4	6100	4850
		6	7050	5650
		8	7750	6150
250 M	.... 25 .	2	5800	4600
		4	7400	6050
		6	8500	7050
		8	9350	7850
280 S, 280 M	.... 28 .	2	–	–
315 S, 315 M	.... 310 .... 313	2	5650	4650
315 L	.... 316 .... 317	2	5450	4650

#### Admissible cantilever forces at 50 Hz for 1MA and 1MJ motors

##### Parallel roller bearings at the drive end (DE) – Order code K20

For motors

Frame size	Type	Number of poles	Admissible cantilever force $F_Q$	
			at $x_0$	at $x_{max}$
			N	N
<b>1MA6 ... 1MJ7 ...</b>				
225	.... 22 .	2	8100	6800
		4	9800	7800
		6	11200	8800
		8	12200	9700
250	.... 25 .	2	9600	7900
		4	11600	9600
		6	13200	10800
		8	14400	11800
280 <sup>1) 2)</sup>	.... 28 .	2	10000	8400
315 S <sup>1) 2)</sup>	.... 310	2	12000	10200
315 M <sup>1) 2)</sup>	.... 313			
315 L <sup>1) 2)</sup>	.... 316	2	11800	10200
	.... 317		(horizontal type of construction)	
<b>1LA8 1PQ8</b>				
315 to 355		2 to 8	See diagrams Page 0/70	

It should be observed that for types of construction IM B6, IM B7, IM B8, IM V5 and IM V6 the belt tension is only permitted to act parallel to the mounting plane or towards the mounting plane and the feet must be supported.

<sup>1)</sup> Admissible cantilever forces for 1LG4, 1LG6, 1LP4, 1PP4 and 1MA6 frame sizes 280 to 315 L in 4-pole to 8-pole version, see Page 0/70.

<sup>2)</sup> Not applicable to 1MJ motors with frame sizes 280 to 315, because this is the standard version.

# IEC Squirrel-Cage Motors

## Introduction motors 1LA, 1LG, 1LL, 1LP, 1MA, 1MJ, 1PP, 1PQ

### General technical data

0

Admissible cantilever forces at 50 Hz for 1LA8 and 1PQ8 motors – basic version

Frame size 315, 1LA8 and 1PQ8 – Type of construction IM B3

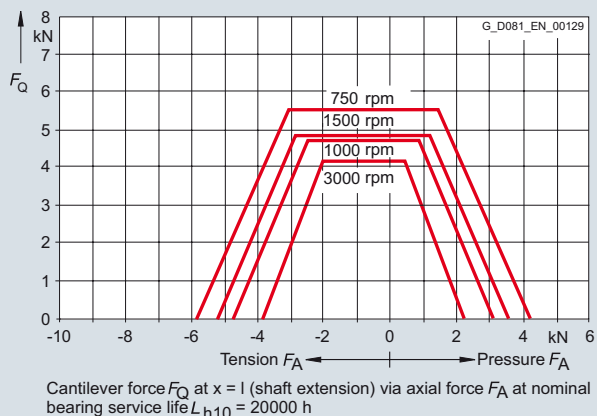

Frame size 355, 1LA8 and 1PQ8 – Type of construction IM B3

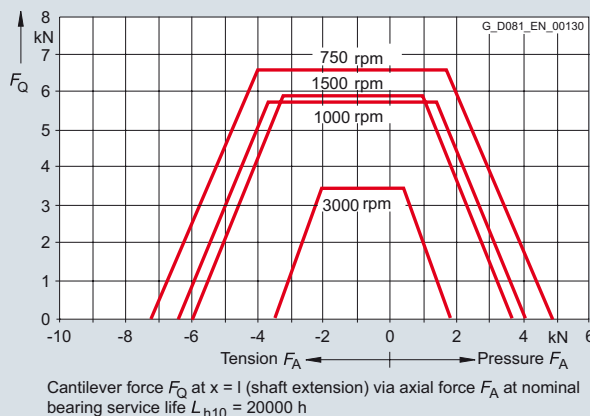

Frame size 400, 1LA8 and 1PQ8 – Type of construction IM B3

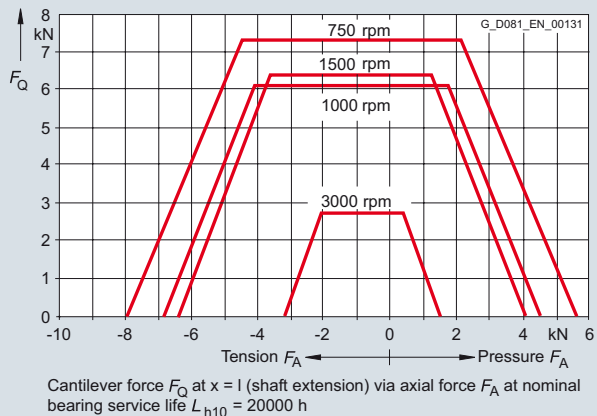

Frame size 450, 1LA8 and 1PQ8 – Type of construction IM B3

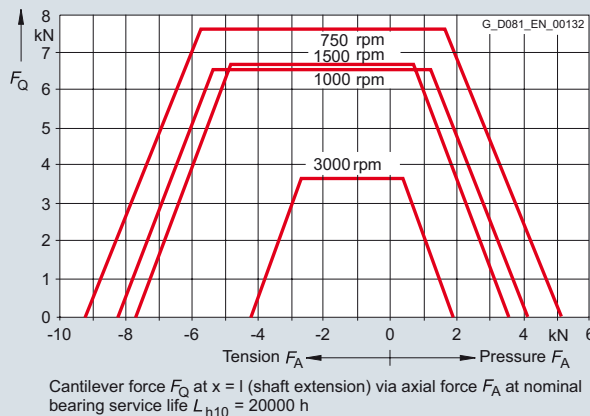

# IEC Squirrel-Cage Motors

## Introduction motors 1LA, 1LG, 1LL, 1LP, 1MA, 1MJ, 1PP, 1PQ

### General technical data

0

Admissible cantilever forces at 50 Hz for 1LA8 and 1PQ8 motors – Bearings for increased cantilever forces – Order code **K20**

Frame size 315, 1LA8 and 1PQ8 – Type of construction IM B3

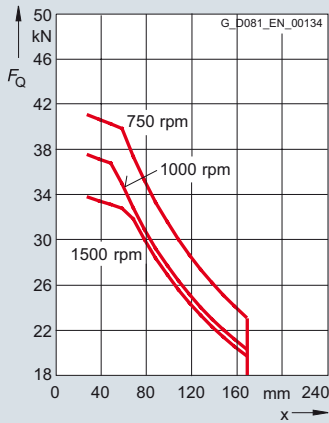

Frame size 355, 1LA8 and 1PQ8 – Type of construction IM B3

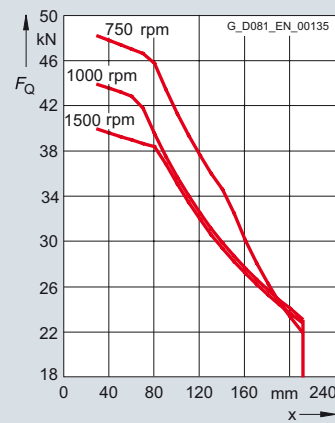

At 60 Hz, the admissible cantilever force must be reduced to 80 %.

For all motors of frame sizes 400 and 450, IM V1 and 1LL8 motors with reinforced bearings available on request. Please specify cantilever force and lever arm.

Admissible cantilever forces at 50 Hz for 1LG motors – Bearings for increased cantilever forces – Order code **K20**

Frame size 280, 4-pole to 8-pole, 1LG4/1LG6, 1LP4/1PP4

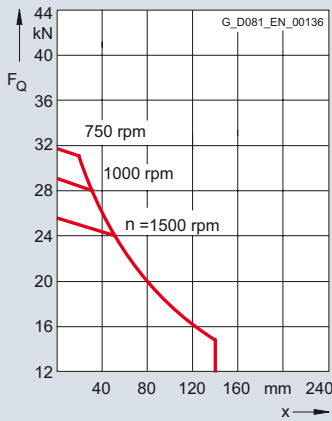

Frame size 315, 4-pole to 8-pole, 1LG4/1LG6, 1LP4/1PP4

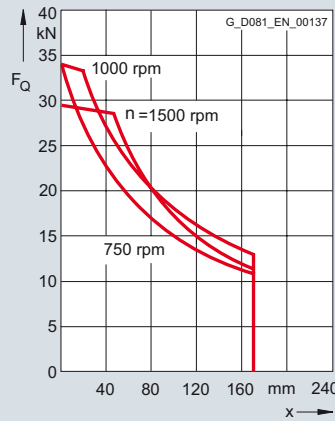

Frame size 315 S/M, 4-pole to 8-pole, 1LG4/1LG6, 1LP4/1PP4

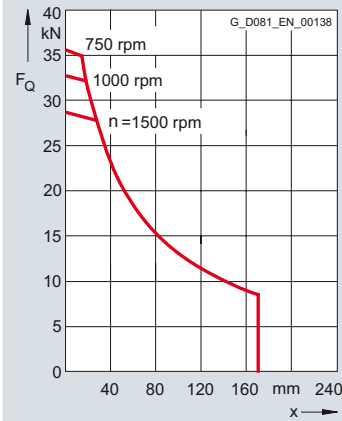

Admissible cantilever forces at 50 Hz for 1MA motors – Bearings for increased cantilever forces – Order code **K20**

Frame size 280, 4-pole to 8-pole, 1MA6

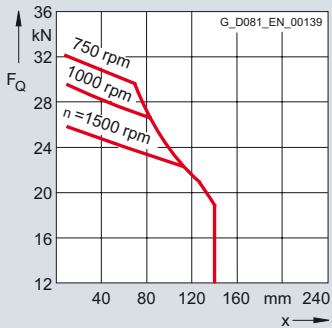

Frame size 315 S/M, 4-pole to 8-pole, 1MA6

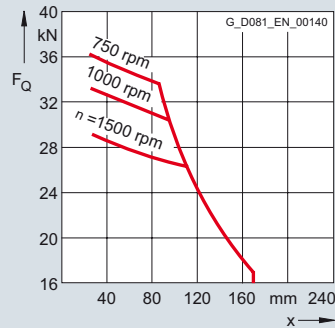

Frame size 315 L, 4-pole to 8-pole, 1MA6

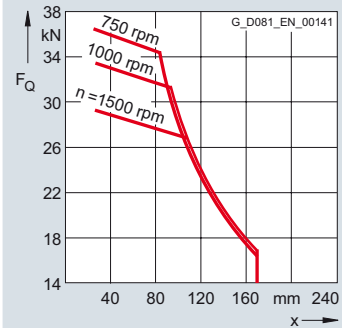



# IEC Squirrel-Cage Motors

## Introduction motors 1LA, 1LG, 1LL, 1LP, 1MA, 1MJ, 1PP, 1PQ

### General technical data

#### Admissible axial load

#### 1LA5, 1LA6, 1LA7, 1LP5, 1LP7, 1MA6, 1MA7, 1MJ6, 1MJ7, 1PP5, 1PP6, 1PP7 motors in vertical type of construction – basic version

Frame size	Shaft extension pointing															
	3000 rpm				1500 rpm				1000 rpm				750 rpm			
	downwards		upwards		downwards		upwards		downwards		upwards		downwards		upwards	
	Load down	Load up	Load down	Load up	Load down	Load up	Load down	Load up	Load down	Load up	Load down	Load up	Load down	Load up	Load down	Load up
56	80	245	230	95	80	330	310	95	80	410	390	95	–	–	–	–
63	80	245	230	95	80	330	310	95	80	410	390	95	–	–	–	–
71	105	365	335	130	90	380	440	130	90	590	550	130	90	700	660	130
80	110	425	360	160	100	540	480	165	100	650	590	165	100	760	700	165
90	110	440	360	180	100	680	580	190	100	920	820	190	100	1150	1050	190
100	140	700	550	280	130	990	820	285	130	1280	1110	285	130	1560	1390	285
112	140 (140)*	710 (1050)*	550 (800)*	300 (300)*	130 (130)*	1000 (1350)*	820 (1100)*	310 (300)*	130 (130)*	1290 (1720)*	1110 (1500)*	310 (310)*	130 (130)*	1570 (2000)*	1390 (1850)*	310 (310)*
132	200 (1500)*	1200 (1550)*	950 (1300)*	470 (470)*	180 (1500)*	1680 (2100)*	1200 (1600)*	470 (470)*	180 (280)*	1900 (2400)*	1600 (2100)*	470 (470)*	190 (290)*	2200 (2800)*	1900 (2400)*	440 (440)*
160	1500 (2000)*	1400 (1720)*	950 (1300)*	1900 (2500)*	1900 (2500)*	1800 (2400)*	1300 (1720)*	2200 (2800)*	2200 (2800)*	1600 (2800)*	2700 (3600)*	2700 (3600)*	2700 (3600)*	2700 (3600)*	1950 (2600)*	2900 (3700)*

For motors Frame size	Shaft extension downwards															
	3000 rpm				1500 rpm				1000 rpm				750 rpm			
	Type	Load down	Load up	Load down	Load up	Load down	Load up	Load down	Load up	Load down	Load up	Load down	Load up	Load down	Load up	
	1LA5... 1LA6... 1MJ6... 1MJ7... 1LP5... 1PP5...	1MJ6... 1MA6... 1LP5... 1PP5...	1LA5... 1MA6... 1LP5... 1PP5...	1MJ6... 1MJ7... 1LP5... 1PP5...	1LA5... 1MA6... 1LP5... 1PP5...	1MJ6... 1MJ7... 1LP5... 1PP5...	1LA5... 1MA6... 1LP5... 1PP5...	1MJ6... 1MJ7... 1LP5... 1PP5...	1LA5... 1MA6... 1LP5... 1PP5...	1MJ6... 1MJ7... 1LP5... 1PP5...	1LA5... 1MA6... 1LP5... 1PP5...	1MJ6... 1MJ7... 1LP5... 1PP5...	1LA5... 1MA6... 1LP5... 1PP5...	1MJ6... 1MJ7... 1LP5... 1PP5...	1LA5... 1MA6... 1LP5... 1PP5...	1MJ6... 1MJ7... 1LP5... 1PP5...
	N	N	N	N	N	N	N	N	N	N	N	N	N	N	N	N
180 M	183	1150	1150	1900	1900	1400	1400	2350	2350	–	–	–	–	–	–	–
180 L	186	–	–	–	–	1400	1400	2400	2400	1700	1700	2850	2850	2000	2000	3150
200 L	206	1650	1650	2750	2750	–	–	–	–	2550	2550	3950	3950	–	–	–
	207	1550	1550	2800	2800	2000	2000	3350	3350	2400	2400	3950	3950	2800	2800	4500
225 S	220	–	–	–	–	2300	2300	3020	3020	–	–	–	–	3200	3200	4080
225 M	223	1890	1890	2190	2190	2180	2180	3060	3060	2700	2700	3500	3500	3040	3040	4120
250 M	253	1750	1750	2790	2790	2160	2160	3760	3760	2740	2740	4340	4340	2990	2990	4890
280 S	280	380	1150	4480	3850	3830	1350	8790	4950	5340	2350	10000	5650	6280	2850	11000
280 M	283	180	900	4580	3900	3550	1000	8910	5000	5000	2000	10100	5700	5930	2450	11100
315 S	310	210	900	5270	4500	3700	1700	10200	6400	5150	2300	11700	7050	6520	3400	13000
315 M	313	100	650	5350	4550	3330	1600	10400	6900	4740	2050	11700	7500	5800	2800	13000
315 L	316	9270	–	770	–	2330	–	10400	–	3650	–	11700	–	4630	–	13000
	317	9270	–	840	–	1370	–	10800	–	2990	–	11600	–	3760	–	13000
	318	9270	–	840	–	1370	–	10800	–	2990	–	11600	–	3760	–	13000

The values shown do not assume a cantilever force on the shaft extension.

The admissible loads are valid for operation at 50 Hz; for 60 Hz, please inquire.

The calculation of the admissible axial load was based on the drive with generally available coupling. For suppliers, see the relevant catalog part, section "Accessories".

Please inquire if the load direction alternates.

\* The values in brackets for frame sizes 112 to 160 apply to 1MJ6 motors.

# IEC Squirrel-Cage Motors

## Introduction motors 1LA, 1LG, 1LL, 1LP, 1MA, 1MJ, 1PP, 1PQ

### General technical data

#### 1LA5, 1LA6, 1LA7, 1LP7, 1MA6, 1MA7, 1MJ6, 1MJ7, 1PP6, 1PP7 motors in horizontal type of construction – Basic version

Frame size	3000 rpm				1500 rpm				1000 rpm				750 rpm			
	Tensile load		Thrust load (N) with radial load at		Tensile load		Thrust load (N) with radial load at		Tensile load		Thrust load (N) with radial load at		Tensile load		Thrust load (N) with radial load at	
	$X_0$	$X_{max.}$	$X_0$	$X_{max.}$	$X_0$	$X_{max.}$	$X_0$	$X_{max.}$	$X_0$	$X_{max.}$	$X_0$	$X_{max.}$	$X_0$	$X_{max.}$	$X_0$	$X_{max.}$
N	N	N	N	N	N	N	N	N	N	N	N	N	N	N	N	N
56	90	120	90	240	90	140	110	320	90	170	120	400	–	–	–	–
63	90	120	90	240	90	140	110	320	90	170	120	400	–	–	–	–
71	120	150	120	350	120	210	150	460	120	260	180	570	120	300	210	680
80	140	190	150	400	140	300	260	510	140	330	280	620	140	340	290	730
90	150	300	280	400	150	400	360	630	150	480	430	870	150	550	500	1100
100	220	450	350	630	220	600	500	910	220	650	550	1200	220	750	650	1480
112	220 (220)*	450 (850)*	350 (700)*	630 (1050)*	220 (220)*	600 (1150)*	500 (1000)*	910 (1350)*	220 (220)*	650 (1300)*	550 (1150)*	1200 (1720)*	220 (220)*	750 (1450)*	650 (1300)*	1480 (2000)*
132	350 (350)*	650 (1000)*	520 (900)*	1200 (1550)*	350 (350)*	850 (1250)*	700 (1150)*	1600 (2100)*	350 (350)*	1020 (1500)*	890 (1400)*	1900 (2400)*	350 (350)*	1150 (1750)*	1020 (1650)*	2200 (2800)*
160	1500 (2100)*	850 (1280)*	720 (1100)*	1500 (2100)*	1500 (2100)*	1050 (1680)*	920 (1700)*	1800 (2350)*	1500 (2100)*	1250 (2050)*	1120 (1920)*	2200 (2900)*	1500 (2100)*	1350 (2400)*	1220 (2200)*	2600 (3300)*

Frame size	Type	3000 rpm		1500 rpm		1000 rpm		750 rpm	
		Tension	Thrust	Tension	Thrust	Tension	Thrust	Tension	Thrust
180 M	... 183	1400	1400	1700	1700	–	–	–	–
180 L	... 186	–	–	1700	1700	2050	2050	2400	2400
200 L	... 206	2000	2000	–	–	3000	3000	–	–
	... 207	1950	1950	2450	2450	2900	2900	3400	3400
225 S	... 220	–	–	2980	1960	–	–	3880	2860
225 M	... 223	2390	1370	2900	1880	3380	2360	3810	2790
250 M	... 253	2450	1655	3070	2270	3620	2820	4000	3200
280 S	... 280	1330 (3700)*	2900 (2100)*	5080 (4200)*	6740 (2600)*	6410 (5000)*	8070 (3400)*	7390 (5550)*	9050 (3950)*
280 M	... 283	1200 (3600)*	2800 (2000)*	4990 (4000)*	6650 (2400)*	6260 (4800)*	7920 (3200)*	7220 (5350)*	8880 (3750)*
315 S	... 310	1500 (3800)*	3160 (2200)*	5350 (4900)*	7450 (3300)*	6740 (5500)*	8810 (3900)*	8010 (6500)*	10110 (4900)*
315 M	... 313	1400 (3650)*	3180 (2050)*	5260 (4900)*	7360 (3300)*	6560 (5450)*	8660 (3850)*	7690 (6250)*	9790 (4650)*
315 L	... 316	1080	2740	4580	6680	5770	7870	6820	8920
	... 317	940	2600	4170	6270	5410	7510	6410	8510
	... 318	940	2600	4170	6270	5410	7510	6410	8510

The values shown do not assume a cantilever force on the shaft extension.

The admissible loads are valid for operation at 50 Hz; for 60 Hz, please inquire.

The calculation of the admissible axial load was based on the drive with generally available coupling. For suppliers, see the relevant catalog part, section "Accessories".

Please inquire if the load direction alternates.

\* The values in brackets for frame sizes 112 to 160 apply to 1MJ6 motors and frame sizes 280 S to 315 M apply to 1MJ7 motors.

# IEC Squirrel-Cage Motors

## Introduction motors 1LA, 1LG, 1LL, 1LP, 1MA, 1MJ, 1PP, 1PQ

### General technical data

#### 1LG4, 1LG6, 1LP4, 1PP4 and 1PP6 motors in vertical type of construction – Basic version

For motors									
Frame size	Type	3000 rpm		1500 rpm		1000 rpm		750 rpm	
	1LG4 ...	Load	Load	Load	Load	Load	Load	Load	Load
	1LG6 ...	down	up	down	up	down	up	down	up
	1LP4 ...								
	1PP4 ...								
	1PP6 ...	N	N	N	N	N	N	N	N
<b>Shaft extension downwards</b>									
180 M	... 183	1140	1150	1500	1600	–	–	–	–
180 L	... 186	–	–	1380	1630	1650	2000	2020	2250
	... 188	1140	1190	1390	1650	1640	2030	1880	2280
200 L	... 206	1610	1480	–	–	2420	2550	–	–
	... 207	1510	1530	2030	2100	2220	2610	2610	2970
	... 208	1510	1590	1990	2120	2210	2680	2600	3060
225 S	... 220	–	–	2110	2690	–	–	2830	3710
225 M	... 223	1540	1990	1920	2770	2260	3300	2620	3770
	... 228	1540	2070	1950	2840	2240	3430	2610	3880
250 M	... 253	1680	2760	2110	3740	2740	4350	3070	4920
	... 258	1660	2870	2110	3960	2740	4520	3070	5160
280 S	... 280	390	4670	3190	8200	4510	9290	5510	10300
280 M	... 283	100	4780	2790	8340	4210	9450	5200	10400
	... 288	100	4950	2700	8570	4170	9600	5160	10600
315 S	... 310	840	6330	3380	10200	4760	11500	5860	12600
315 M	... 313	530	6490	2870	10500	4200	11800	5420	12900
315 L	... 316	8830	590	2450	11000	3680	12300	4800	13400
	... 317	8410	690	1800	11400	3100	12800	4410	13900
	... 318	8170	800	1620	12000	2690	13400	3820	14300
<b>Shaft extension pointing upwards</b>									
180 M	... 183	1900	390	2260	840	–	–	–	–
180 L	... 186	–	–	2140	870	2410	1240	2780	1490
	... 188	1900	430	2150	890	2400	1270	2640	1520
200 L	... 206	2760	330	–	–	3570	1400	–	–
	... 207	2660	380	3180	950	3370	1460	3760	1820
	... 208	2660	440	3140	970	3360	1530	3750	1910
225 S	... 220	–	–	3130	1670	–	–	3850	2690
225 M	... 223	2560	970	2940	1750	3280	2280	3640	2750
	... 228	2560	1050	2970	1820	3260	2410	3630	2860
250 M	... 253	2480	1960	2910	2940	3540	3550	3870	4120
	... 258	2460	2070	2910	3160	3540	3720	3870	4360
280 S	... 280	1960	3100	4760	6630	6080	7720	7080	8730
280 M	... 283	1670	3210	4360	6770	5780	7880	6770	8830
	... 288	1670	3380	4270	7000	5740	8030	6730	9030
315 S	... 310	2410	4760	5380	8200	6760	9500	7860	10600
315 M	... 313	2100	4920	4870	8500	6200	9800	7420	10900
315 L	... 316	10400	–	4450	9000	5680	10300	6800	11400
	... 317	9980	–	3800	9400	5100	10800	6410	11900
	... 318	9740	–	3620	10000	4690	11400	5820	12300

Values shown without assuming a cantilever force on the shaft extension.

The admissible loads apply to operation at 50 Hz; please inquire about 60 Hz.

The figures for the admissible axial loads have been calculated assuming that standard coupling types are used for the drive.

For suppliers, see the relevant catalog part, section "Accessories".

Please inquire if the loading direction alternates.

# IEC Squirrel-Cage Motors

## Introduction motors 1LA, 1LG, 1LL, 1LP, 1MA, 1MJ, 1PP, 1PQ

### General technical data

#### 1LG4, 1LG6, 1LP4, 1PP4 and 1PP6 motors in horizontal type of construction – Basic version

For motors Frame size	Type	3000 rpm		1500 rpm		1000 rpm		750 rpm	
		Loading direction		Loading direction		Loading direction		Loading direction	
		Tension	Thrust	Tension	Thrust	Tension	Thrust	Tension	Thrust
	1LG4 ...								
	1LG6 ...								
	1LP4 ...								
	1PP4 ...								
	1PP6 ...	N	N	N	N	N	N	N	N
180 M	... 183	1550	790	1950	1190	–	–	–	–
180 L	... 186	–	–	1890	1130	2220	1460	2470	1710
	... 188	1550	790	1900	1140	2220	1460	2460	1700
200 L	... 206	2150	990	–	–	3090	1940	–	–
	... 207	2130	970	2670	1520	3030	1880	3410	2260
	... 208	2130	970	2630	1480	3020	1870	3410	2250
225 S	... 220	–	–	2950	1920	–	–	3820	2790
225 M	... 223	2320	1290	2910	1880	3360	2330	3760	2740
	... 228	2320	1290	2910	1880	3350	2320	3760	2730
250 M	... 253	2510	1710	3150	2350	3750	2950	4180	3380
	... 258	2510	1710	3140	2340	3750	2950	4170	3370
280 S	... 280	1790	3360	4970	6540	6180	7750	7170	8740
280 M	... 283	1720	3290	4860	6430	6110	7680	7090	8660
	... 288	1720	3290	4850	6420	6100	7670	7080	8650
315 S	... 310	2610	4180	5520	7520	6830	8830	7940	9940
315 M	... 313	2500	4070	5320	7320	6520	8520	7850	9850
315 L	... 316	2450	4020	5230	7230	6370	8370	7520	9520
	... 317	2320	3890	5050	7050	6110	8110	7350	9350
	... 318	2300	3870	4950	6950	5950	7950	7080	9080

#### 1LA8 and 1PQ8 motors in vertical type of construction – Basic version

For motors Frame size	Type	Shaft extension facing downwards				1000 rpm		750 rpm	
		3000 rpm		1500 rpm		Load down	Load up	Load down	Load up
		Load down	Load up	Load down	Load up				
	1LA8 ...								
	1PQ8 ...								
	1LL8 ...	N	N	N	N	N	N	N	N
315	... 315	1900	5240	2790	6930	3060	8600	3850	9390
	... 317	1440	5680	2280	7420	2390	9230	3190	10030
355	... 353	8480	5570	14550	7900	–	–	–	–
	... 355	8180	5860	14200	8240	15690	10650	17840	11650
	... 357	7530	6500	13400	9030	14540	11780	16690	12780
400	... 403	6780	7260	17640	11160	19500	14160	22260	15330
	... 405	6330	7700	17040	11750	18750	14910	21510	16070
	... 407	5930	8100	16340	12440	17900	15750	20660	16910
450	... 453	5330	9650	17720	13020	19950	16250	23040	17550
	... 455	4730	10250	17020	13720	19050	17140	22140	18440
	... 457	4130	10840	16270	14460	18000	18180	21090	19480

For 1LA8 and 1PQ8 motors in a horizontal type of construction, the admissible cantilever forces are specified with regard to the axial forces, see Page 0/69.

Data is available for 1LL8 motors on request.

Values shown without assuming a cantilever force on the shaft extension.

The admissible loads apply to operation at 50 Hz; please inquire about 60 Hz.

The figures for the admissible axial loads have been calculated assuming that standard coupling types are used for the drive.

For suppliers, see the relevant catalog part, section "Accessories".

Please inquire if the loading direction alternates.

### Modular technology

#### Basic versions

The range of potential applications for the 1LA and 1LG motors can be broadened considerably by mounting the following modules (e.g. the motors can be used as brake motors).

- **1XP8 001** rotary pulse encoder, frame sizes 71 M to 315 L
- Separately driven fan, frame sizes 100 L to 315 L
- Brake, frame sizes 63 to 315 L

The brake must always be mounted in the factory for safety reasons. The rotary pulse encoder and/or the separately driven fan can also be retrofitted.

The degree of protection of the motors with modular technology is IP55. Higher degrees of protection on request.

When a rotary pulse encoder, brake or separately driven fan is mounted, the length of the motor increases by  $\Delta l$ . For an explanation of the additional dimensions and weights, see "Technology", "Dimensions and weights".

#### 1XP8 001 rotary pulse encoder



1XP8 001 rotary pulse encoder

The rotary pulse encoder can be supplied already mounted in an HTL version as **1XP8 001-1** with order code **H57** or in a TTL version as **1XP8 001-2** with order code **H58**. The rotary pulse encoder can only be mounted on a standard non-drive end (NDE), i.e. a second shaft extension or protective cover cannot be supplied.

It can also be ordered separately and retrofitted (please inquire beforehand), Order No. **1XP8 001-1** or **1XP8 001-2** (see catalog part 2 "Standard motors", "Accessories").

The 1XP8 001 rotary pulse encoder is suitable for standard applications. The encoder does not have insulated bearings; therefore, it cannot be recommended at the risk of bearing currents in combination with insulated bearing cartridge NDE, order code L27, or with insulated bearing cartridge DE. For further encoders, see "Special technology" from Page 0/85.

All 1LG4 and 1LG6 motors that are listed in the catalog have an M16 center hole, form DS on the non-drive end (NDE). When a rotary pulse encoder is mounted, the length of the motor increases by  $\Delta l$ . For an explanation of the additional dimensions and weights, see "Technology", "Dimensions and weights".

The rotary pulse encoders of "Modular technology" and "Special technology" are fitted as standard with a protective cover made of plastic. A protective cover made of non-corrosive sheet steel is available for 1LA5, 1LA6 and 1LA7 motors, see "Mechanical protection for encoders", order code **M68**, under "Mechanical design and degrees of protection".

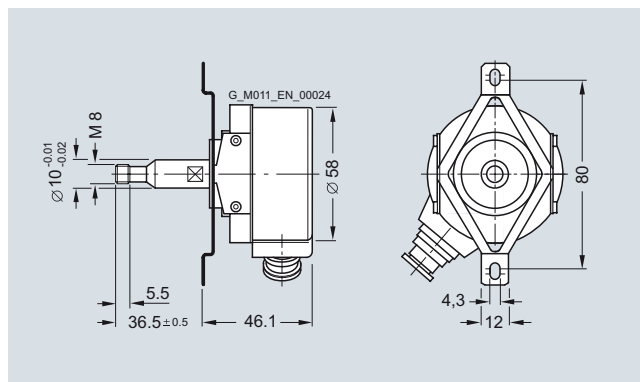

Mounting dimensions of 1XP8 001 rotary pulse encoder

Mounting of encoder at temperatures below  $-20\text{ °C}$  and higher than  $+40\text{ °C}$  on request.

#### Technical data of rotary pulse encoders

	<b>1XP8 001-1</b> (HTL version)	<b>1XP8 001-2</b> (TTL version)
Supply voltage $U_B$	+10 V to +30 V	5 V $\pm 10\%$
Current input without load	200 mA	150 mA
Admissible load current per output	max. 100 mA	max. 20 mA
Pulses per revolution	1024	1024
Outputs	2 square-wave pulses A, B – 2 inverted square-wave pulses A, B Zero pulse and inverted zero pulse	
Pulse offset between the two outputs	$90^\circ \pm 20\%$	$90^\circ \pm 20\%$
Output amplitude	$U_{High} > U_B - 3.5\text{ V}$ $U_{Low} < 3\text{ V}$	$U_{High} > 2.5\text{ V}$ $U_{Low} < 0.5\text{ V}$
Minimum edge interval	0.8 $\mu\text{s}$ at 160 kHz	0.45 $\mu\text{s}$ at 300 kHz
Edge steepness (without load or cable)	$t_r, t_f \leq 200\text{ ns}$	$t_r, t_f \leq 100\text{ ns}$
Maximum frequency	160 kHz	300 kHz
Maximum speed	9000 rpm	12000 rpm
Temperature range	$-20$ to $+80\text{ °C}$	$-20$ to $+100\text{ °C}$
Degree of protection	IP66	IP66
Admissible radial cantilever force	60 N	60 N
Admissible axial force	40 N	40 N
Termination system	12-pin connector (mating connector is supplied)	
Certification	CSA, UL	CSA, UL
Weight	0.3 kg	0.3 kg

# IEC Squirrel-Cage Motors

## Introduction motors 1LA, 1LG, 1LL, 1LP, 1MA, 1MJ, 1PP, 1PQ

### General technical data

#### Separately driven fan

The use of a separately driven fan is recommended to increase motor utilization at low speeds and to limit noise generation at speeds significantly higher than the synchronous speed. Both of these results can only be achieved with converter-fed operation. Please inquire about traction and vibratory operation.

The separately driven fan can be supplied already fitted, order code **G17**.

It can also be ordered separately and retrofitted. For selection information and order numbers, see catalog part 2 "Standard motors", "Accessories". A rating plate listing all the important data is fitted to the separately driven fan. Order code **Y81** and

plain text are required for supply voltages outside the rated voltage ranges for 1LG motors. Please note the direction of rotation of the separately driven fan (axial-flow fan) when connecting it. The admissible coolant temperatures for frame sizes 100 to 225 <sup>1)</sup> are  $CT_{min.} -25\text{ °C}$  and  $CT_{max.} +65\text{ °C}$  <sup>2)</sup>, lower/higher coolant temperatures on request. The admissible coolant temperatures for frame sizes 250 to 315 are  $CT_{min.} -20\text{ °C}$  and  $CT_{max.} +50\text{ °C}$ , lower/higher coolant temperatures on request.

When a separately driven fan is mounted, the length of the motor increases by  $\Delta l$ . For an explanation of the additional dimensions and weights, see "Technology", "Dimensions and weights".

#### Technical data of the separately driven fan (in accordance with tolerance DIN EN 60034-1)

Frame size	Rated voltage range		Frequency Hz	Rated speed rpm	Power consumption kW	Rated current A
	V					
100	1 AC	230 to 277	50	2790	0.075	0.29
	3 AC	220 to 290 $\Delta$	50	2830	0.086	0.27
	3 AC	380 to 500 Y	50	2830	0.086	0.16
	1 AC	230 to 277	60	3280	0.094	0.28
	3 AC	220 to 332 $\Delta$	60	3490	0.093	0.27
	3 AC	380 to 575 Y	60	3490	0.093	0.16
112	1 AC	230 to 277	50	2720	0.073	0.26
	3 AC	220 to 290 $\Delta$	50	2770	0.085	0.27
	3 AC	380 to 500 Y	50	2770	0.085	0.15
	1 AC	230 to 277	60	3000	0.107	0.31
	3 AC	220 to 332 $\Delta$	60	3280	0.094	0.28
	3 AC	380 to 575 Y	60	3280	0.094	0.16
132	1 AC	230 to 277	50	2860	0.115	0.40
	3 AC	220 to 290 $\Delta$	50	2880	0.138	0.45
	3 AC	380 to 500 Y	50	2880	0.138	0.24
	1 AC	230 to 277	60	3380	0.185	0.59
	3 AC	220 to 332 $\Delta$	60	3470	0.148	0.41
	3 AC	380 to 575 Y	60	3470	0.148	0.24
160 to 225 <sup>3)</sup>	1 AC	230 to 277	50	2780	0.236	0.96
	3 AC	220 to 290 $\Delta$	50	2840	0.220	0.76
	3 AC	380 to 500 Y	50	2830	0.220	0.43
	3 AC	220 to 332 $\Delta$	60	3400	0.284	0.94
	3 AC	380 to 575 Y	60	3400	0.284	0.56
250 M to 280 M	3 AC	200 to 240 $\Delta$	50	2720	0.450	2.00
	3 AC	380 to 420 Y	50	2720	0.450	1.15
	3 AC	440 to 480 Y	60	3320	0.520	1.05
315 2-pole	3 AC	200 to 240 $\Delta$	50	2750	0.650	2.85
	3 AC	380 to 420 Y	50	2750	0.650	1.64
	3 AC	440 to 480 Y	60	3365	0.750	1.60
315 4, 6, 8-pole	3 AC	200 to 240 $\Delta$	50	2720	0.450	2.00
	3 AC	380 to 420 Y	50	2720	0.450	1.15
	3 AC	440 to 480 Y	60	3320	0.520	1.05

<sup>1)</sup> Separately driven fans with order numbers **1PP...** are used for 1LG motors of frame size 225 and above. The admissible coolant temperatures are  $CT_{min.} -20\text{ °C}$  and  $CT_{max.} +50\text{ °C}$

<sup>2)</sup> The admissible coolant temperature for single phase versions (1AC) for frame size 160 and above is  $CT_{max.} +50\text{ °C}$ .

<sup>3)</sup> Separately driven fans with order numbers **1PP...** are used for 1LG motors of frame size 225 and above. The values for frame sizes 250 M to 280 M are then applicable.

# IEC Squirrel-Cage Motors

## Introduction motors 1LA, 1LG, 1LL, 1LP, 1MA, 1MJ, 1PP, 1PQ

### General technical data

#### Mounting of separately driven fan and rotary pulse encoder with separately driven fan for 1LA5, 1LA6, 1LA7 and 1LG motors

Version	Frame size	Number of poles	Order No.
<b>Separately driven fan</b> incl. mounting parts <sup>1)</sup>	100	all	<b>2CW2 180-8RF54-1AB0</b>
	112	all	<b>2CW2 210-8RF54-1AB1</b>
	132	all	<b>2CW2 250-8RF54-1AB2</b>
	160	all	<b>2CW2 300-8RF54-1AB3</b>
	180	all	<b>2CW2 300-8RF54-1AB4</b>
	200	all	<b>2CW2 300-8RF54-1AB5</b>
	225 <sup>2)</sup>	all	<b>2CW2 300-8RF54-1AB6</b>
	250	all	<b>1PP9 063-2LA12-Z A11+K50 <sup>3)</sup></b>
	280	all	<b>1PP9 063-2LA12-Z A11+K50 <sup>3)</sup></b>
	315	2	<b>1PP9 070-2LA12-Z A11+K50 <sup>3)</sup></b>
315	4 to 8	<b>1PP9 063-2LA12-Z A11+K50 <sup>3)</sup></b>	
<b>Separately driven fan and rotary pulse encoder</b> <b>1XP8 001-1</b> (HTL) <sup>4)</sup> incl. mounting parts <sup>1)</sup>	100	all	<b>2CW2 180-8RF54-2AB0</b>
	112	all	<b>2CW2 210-8RF54-2AB1</b>
	132	all	<b>2CW2 250-8RF54-2AB2</b>
	160	all	<b>2CW2 300-8RF54-2AB3</b>
	180	all	<b>2CW2 300-8RF54-2AB4</b>
	200	all	<b>2CW2 300-8RF54-2AB5</b>
	225 <sup>2)</sup>	all	<b>2CW2 300-8RF54-2AB6</b>

### Brakes

Spring-operated disk brakes are used for the brakes with order code **G26**. Depending on the selected motor, brake types **2LM8** or **KFB** are used. In the standard version, the brakes are supplied for connection to 230 V with rectifier. The supply voltage for brakes is explained under "Modular technology – Additional versions".

For the design of each brake type, the braking time, run-on revolutions, braking energy per braking procedure as well as the service life of the brake linings, see "Configuration of motors with brakes".

When a brake is mounted, the length of the motor increases by  $\Delta l$ . For an explanation of the additional dimensions and weights, see "Technology", "Dimensions and weights". When a brake is mounted on a 1LA7 motor, a larger connection box (GK 127) is used for frame sizes 63 to 90.

#### 2LM8 spring-operated disk brake

This brake is mounted on 1LA5 and 1LA7 motors in the frame sizes 63 to 225 and on 1LG motors in the frame sizes 180 to 225 as standard.

The 2LM8 brake has IP55 degree of protection.

Please inquire if motors with brakes are to be operated below the freezing point or in very humid environments (e.g. close to the sea) with long standstill times.

#### Design and mode of operation

The brake takes the form of a single-disk brake with two friction surfaces.

The braking torque is generated by friction when pressure is applied by one or more pressure springs in the de-energized state. The brake is released electromagnetically.

When the motor brakes, the rotor which can be axially shifted on the hub or the shaft is pressed via the armature disk against the friction surface by means of the springs. In the braked state, there is a gap  $S_{\text{Gap}}$  between the armature disk and the solenoid component. To release the brake, the solenoid is energized with DC voltage. The resulting magnetic force pulls the armature disk against the spring force on to the solenoid component. The spring force is then no longer applied to the rotor which can rotate freely.

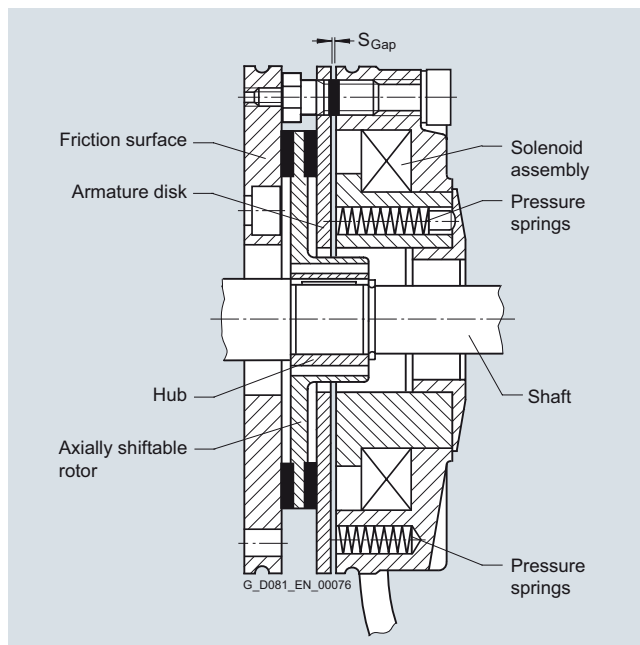

Design of the 2LM8 spring-operated disk brake

#### Rating plate

The motors have a second rating plate on the opposite side to the motor rating plate. The brake data is indicated on this second rating plate.

<sup>1)</sup> The separately driven fan **2CW2 ...** comprises a complete fan unit with impeller, the separately driven fan **1PP9 ...** only comprises the fan motor without mounting components and impeller.

<sup>2)</sup> For 1LG motors with separately driven fan with Order No. **1PP9 063-2LA12-Z A11+K50** (weight 4.37 kg).

<sup>3)</sup> For replacement purposes only.

<sup>4)</sup> Rotary pulse encoder **1XP8001-2** (TTL) on request.

# IEC Squirrel-Cage Motors

## Introduction motors 1LA, 1LG, 1LL, 1LP, 1MA, 1MJ, 1PP, 1PQ

### General technical data

0

#### Operating values for spring-operated brakes with standard excitation

For motor frame size	Brake type	Rated braking torque at 100 rpm	Rated braking torque in relation to rated braking torque at 100 rpm in % for the following speeds			Supply voltage	Current/power input <sup>1)</sup>			Brake application time $t_2$ <sup>2)</sup>	Brake release time	Brake moment of inertia	Noise level $L_p$ with rated air gap	Service capability of the brake					
			1500 rpm	3000 rpm	Max. speed		V	A	W					ms	ms	kg m <sup>2</sup>	dB (A)	Lifetime of brake lining $L$	Air gap adjustment required after braking energy $L_N$
63	2LM8 005-1NA10 2LM8 005-1NA60 2LM8 005-1NA80	5	87	80	65	AC 230	0.1	20	25	56	0.000013	77	105	16					
						AC 400	0.11												
						DC 24	0.83												
71	2LM8 005-2NA10 2LM8 005-2NA60 2LM8 005-2NA80	5	87	80	65	AC 230	0.1	20	25	56	0.000013	77	105	16					
						AC 400	0.11												
						DC 24	0.83												
80	2LM8 010-3NA10 2LM8 010-3NA60 2LM8 010-3NA80	10	85	78	65	AC 230	0.12	25	26	70	0.000045	75	270	29					
						AC 400	0.14												
						DC 24	1.04												
90	2LM8 020-4NA10 2LM8 020-4NA60 2LM8 020-4NA80	20	83	76	66	AC 230	0.15	32	37	90	0.00016	75	740	79					
						AC 400	0.17												
						DC 24	1.25												
100	2LM8 040-5NA10 2LM8 040-5NA60 2LM8 040-5NA80	40	81	74	66	AC 230	0.2	40	43	140	0.00036	80	1350	115					
						AC 400	0.22												
						DC 24	1.67												
112	2LM8 060-6NA10 2LM8 060-6NA60 2LM8 060-6NA80	60	80	73	65	AC 230	0.25	53	60	210	0.00063	77	1600	215					
						AC 400	0.28												
						DC 24	2.1												
132	2LM8 100-7NA10 2LM8 100-7NA60 2LM8 100-7NA80	100	79	72	65	AC 230	0.27	55	50	270	0.0015	77	2450	325					
						AC 400	0.31												
						DC 24	2.3												
160	2LM8 260-8NA10 2LM8 260-8NA60 2LM8 260-8NA80	260	75	68	65	AC 230	0.5	100	165	340	0.0073	79	7300	935					
						AC 400	0.47												
						DC 24	4.2												
180	2LM8 315-0NA10 2LM8 315-0NA60 2LM8 315-0NA80	315	75	68	65	AC 230	0.5	100	152	410	0.0073	79	5500	470					
						AC 400	0.56												
						DC 24	4.2												
200, 225	2LM8 400-0NA10 2LM8 400-0NA60 2LM8 400-0NA80	400	73	68	65	AC 230	0.55	110	230	390	0.0200	93	9450	1260					
						AC 400	0.61												
						DC 24	4.6												

<sup>1)</sup> For 400 V AC and for 24 V DC, the power can deviate by up to +10 % as a function of the selected supply voltage.

<sup>2)</sup> The specified switching times are valid for switching on the DC side with a rated release travel and with the coil already warm. They are average values which may vary depending on factors such as the rectifier type and the release travel. The brake application time for switching on the AC side, for example, is approximately 6 times longer than for switching on the DC side.



### Lifetime of the brake lining

The braking energy  $L_N$  up to when the brake should be adjusted, depends on various factors. The main influencing factors include the masses to be braked, the operating speed, the switching frequency and therefore the temperature at the frictional surfaces. It is therefore not possible to specify a value for the friction energy until readjustment that is valid for all operating conditions.

The specific wear on the friction surfaces (volume of wear per unit of friction energy) is approximately  $0.05$  to  $2 \text{ cm}^3/\text{kWh}$  when the brake is used as a service brake.

### Admissible speeds

The maximum admissible speeds from which emergency stops can be made, are listed in the table. These speeds should be considered as recommended values and must be checked under actual operating conditions.

The maximum admissible friction energy depends on the switching frequency and is shown for the various brakes in the figure "Admissible switching energy as a function of the switching frequency". Increased wear can be expected when the brakes are used for emergency stops.

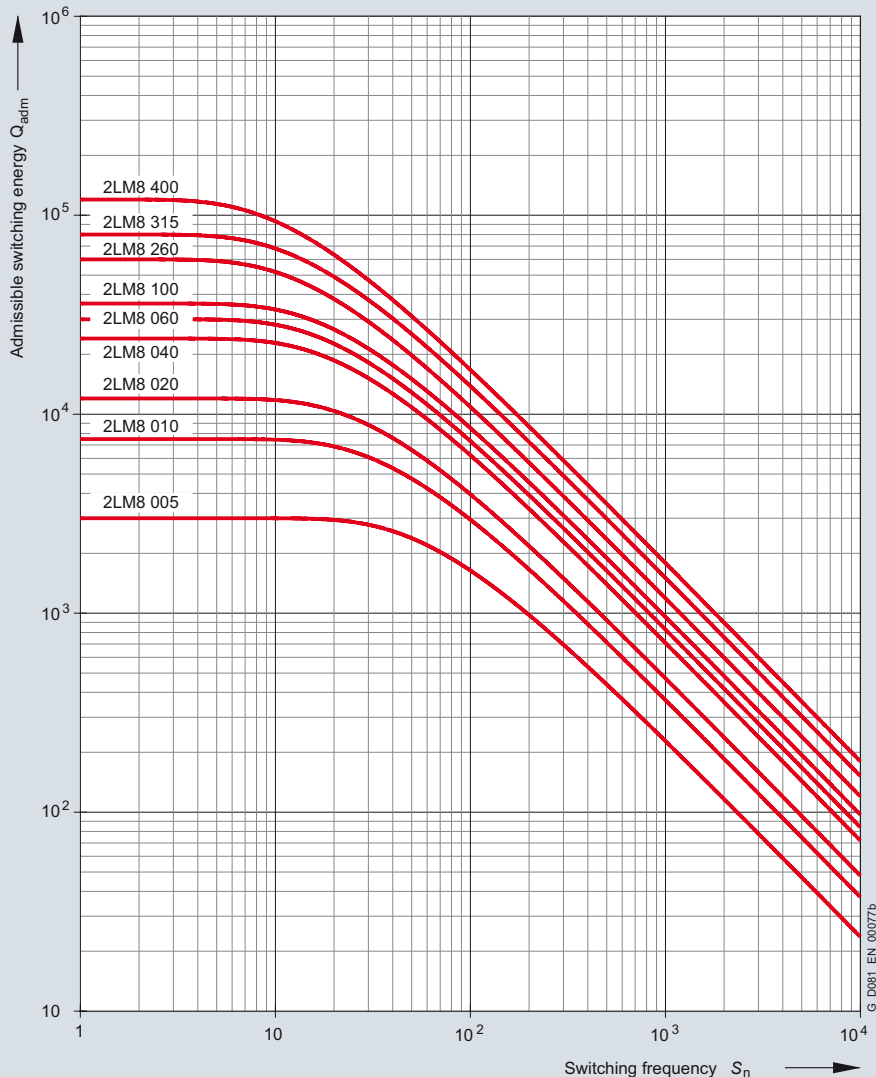

# IEC Squirrel-Cage Motors

## Introduction motors 1LA, 1LG, 1LL, 1LP, 1MA, 1MJ, 1PP, 1PQ

### General technical data

0

For motor frame size	Brake type	Admissible speeds			Changing the braking torque			Readjusting the air gap		
		Max. operating rpm if max. operating energy utilised	Max. no-load rpm with emergency stop function		Reduction per notch	Dim. "O <sub>1</sub> "	Min. braking torque	Rated air gap S <sub>Gap Rated</sub>	Max. air gap S <sub>Gap max.</sub>	Min. rotor thickness h <sub>min.</sub>
			Horizontal mounting	Vertical mounting						
		rpm	rpm	rpm	Nm	mm	Nm	mm	mm	mm
63	<b>2LM8 005-1NA ..</b>	3000	6000	6000	0.17	7.0	3.7	0.2	0.4	4.5
71	<b>2LM8 005-2NA ..</b>	3000	6000	6000	0.17	7.0	3.7	0.2	0.4	4.5
80	<b>2LM8 010-3NA ..</b>	3000	6000	6000	0.35	8.0	7.0	0.2	0.45	5.5
90	<b>2LM8 020-4NA ..</b>	3000	6000	6000	0.76	7.5	18.2	0.2	0.55	7.5
100	<b>2LM8 040-5NA ..</b>	3000	6000	6000	1.29	12.5	21.3	0.3	0.65	8.0
112	<b>2LM8 060-6NA ..</b>	3000	6000	6000	1.66	11.0	32.8	0.3	0.75	7.5
132	<b>2LM8 100-7NA ..</b>	3000	5300	5000	1.55	13.0	61.1	0.3	0.75	8.0
160	<b>2LM8 260-8NA ..</b>	1500	4400	3200	5.6	17.0	157.5	0.4	1.2	12.0
180	<b>2LM8 315-0NA ..</b>	1500	4400	3200	5.6	17.0	178.4	0.4	1.0	12.0
200, 225	<b>2LM8 400-0NA ..</b>	1500	3000	3000	6.15	21.0	248.7	0.5	1.5	15.5

### Changing the braking torque

The brake is supplied with the braking torque already set. For 2LM8 brakes, the torque can be reduced to the dimension O<sub>1</sub> by unscrewing the adjusting ring with a hook spanner. The braking torque changes by the values shown in the above table for each notch of the adjusting ring.

### Readjusting the air gap

Under normal operating conditions, the brake is practically maintenance-free. The air gap S<sub>Gap</sub> must only be checked at regular intervals if the application requires an extremely large amount of frictional energy and readjusted to the rated gap S<sub>Gap Rated</sub> at the latest when the maximum air gap S<sub>Gap max.</sub> is reached.

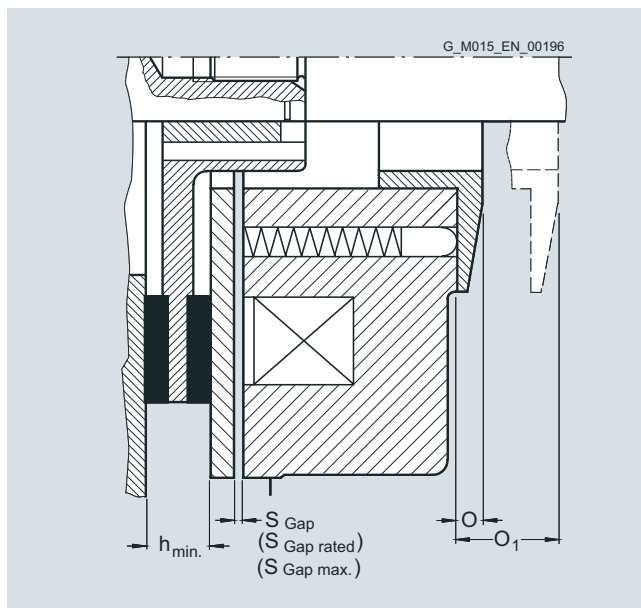

### KFB spring-operated brake

This brake is the standard brake for 1LG motors in frame sizes 250 to 315. For frame sizes 180 to 225, apart from the standard brake 2LM8, KFB brakes can also be supplied. Special brake selections are available on request.



KFB spring-operated brake

The KFB solenoid double-disk spring-operated brake is a safety brake which brakes the motor if the supply is disconnected (power failure, emergency stop). The KFB brake, IP65 degree of protection, is mainly used for electric motors for traversing, cross-traversing and lifting gear in cranes as well as for special industrial applications.

### Design and mode of operation

When the brake current is switched on, an electromagnetic field develops which overcomes the spring force of the brake. The corresponding modules, including the motor shaft, can rotate freely. The brake is released. If the brake current is switched off or if there is a power failure, the electromagnetic field of the brake disappears. The mechanical braking energy is transferred to the motor shaft. The motor is braked.

# IEC Squirrel-Cage Motors

## Introduction motors 1LA, 1LG, 1LL, 1LP, 1MA, 1MJ, 1PP, 1PQ

### General technical data

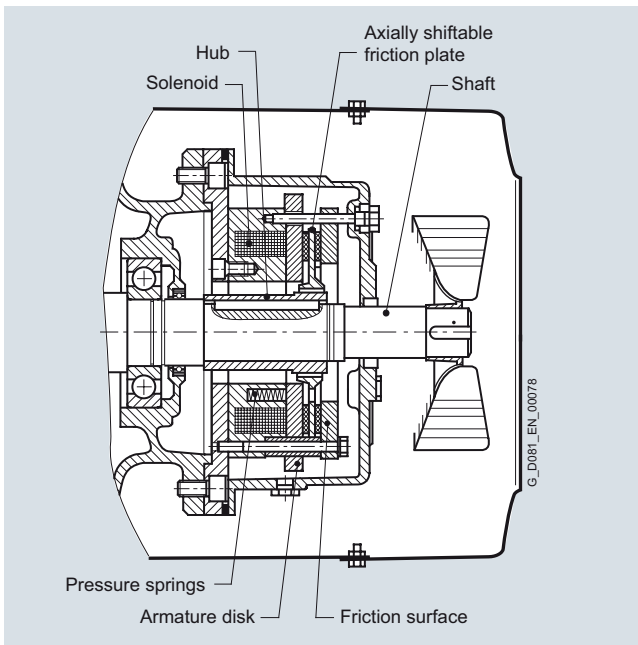

### Rating plate

The motors have a rating plate that indicates the brake data on the opposite side to the motor rating plate.

### Other characteristics of the KFB brake

- High IP65 degree of protection
- Corrosion-resistant in seawater and in the tropics.
- The brake is a dynamic brake, not simply a holding brake. For this reason there is less wear, especially in the case of emergency stops (commissioning).
- High wear reserves – repeated stepless air gap readjustment is possible. This results in extremely long operating times and low service and operating costs.
- The function and wear can be monitored with microswitches and proximity switches. Microswitch On/Off is standard for LG motors. Anti-condensation heating is possible as an option.
- Fully functional brake for enclosure acceptance test. Visual inspection of brake is possible during operation.
- The brake (air gap) can be adjusted in the factory, for example, and mounted on the motor without further adjustments.

The wear parts can be replaced without great outlay. After the housing has been opened (three screws), it is easy to replace the friction plate. It is not necessary to disassemble the entire brake.

### Overview of brake selection for 1LG motors

		For motor Frame size					
		180 <sup>1)</sup>	200 <sup>1)</sup>	225 <sup>1)</sup>	250 <sup>2)</sup>	280 <sup>2)</sup>	315 <sup>2)</sup>
Number of poles		2 to 8	2 to 8	2 to 8	2 to 8	4 to 8	4 to 8
NDE bearing		6310C3	6312C3	6313C3	6215C3	6317C3	6319C3
Flange bearing plate for NDE brake mounting		A300	A350	A350	A400	A450	A550
Max. diameter for 2nd. shaft extension		48k6	55m6	55m6	48m6	65m6	70m6
Brake type		<b>KFB 25</b>	<b>KFB 40</b>	<b>KFB 40</b>	<b>KFB 63</b>	<b>KFB 100</b>	<b>KFB 160</b>
Braking torque	Nm	250	400	400	630	1000	1600
$n_{max}$ – IM B3	rpm	6000	5500	5500	4700	4000	3600
$n_{max}$ – IM V1	rpm	6000	5500	5500	4700	4000	3600
Output at 110 V DC	W	158	196	196	220	307	344
Current at 230 V AC (207 V DC coil voltage)	A	0.77	0.91	0.91	1	1.53	1.64
Current at 400 V AC (180 V DC coil voltage)	A	0.8	1.18	1.18	1.25	1.8	2.1
Current at 110 V DC	A	1.44	1.78	1.78	2	2.79	3.13
Current at 24 V DC	A	5.21	6.92	9.62	8.17	12.2	12.8
Application time $t_2$	ms	70	80	80	110	125	180
Release time	ms	240	250	250	340	370	500
Brake moment of inertia	Kg m <sup>2</sup>	0.0048	0.0068	0.0068	0.0175	0.036	0.050
Lifetime of brake lining $L$	Nm · 10 <sup>6</sup>	3600	3110	3110	4615	7375	10945
Air gap adjustment required after braking energy $L_N$	Nm · 10 <sup>6</sup>	810	935	935	1185	2330	3485

<sup>1)</sup> The standard brake for frame sizes 180 to 225 is the 2LM8 brake. KFB brake on request.

<sup>2)</sup> The standard brake for frame sizes 250 to 315 is the KFB brake.

# IEC Squirrel-Cage Motors

## Introduction motors 1LA, 1LG, 1LL, 1LP, 1MA, 1MJ, 1PP, 1PQ

### General technical data

#### Configuration of motors with brakes

##### Braking time

The time it takes the motor to come to a standstill comprises two components:

- The application time of the brake  $t_2$
- The braking time  $t_{Br}$

$$t_{Br} = \frac{J \cdot n_{rated}}{9.55 \cdot (T_B \pm T_L)}$$

- $t_{Br}$  Braking time in s  
 $J$  Total moment of inertia in  $\text{kgm}^2$   
 $n_{Rated}$  Rated speed of the motor with brake in rpm  
 $T_B$  Rated braking torque in Nm  
 $T_L$  Average load torque in Nm  
 (if  $T_L$  supports braking,  $T_L$  is positive)

##### Braking energy per braking operation $Q_{adm}$

The braking energy per braking operation in Nm comprises the energy of the moments of inertia to be braked  $Q_{Kin}$  and the energy  $Q_L$ , which must be applied in order to brake against a load torque.

$$Q_{adm} = Q_{Kin} + Q_L$$

- The energy of the moments of inertia in Nm

$$Q_{Kin} = \frac{J \cdot n_{rated}^2}{182.4}$$

- $n_{Rated}$  Rated speed before braking in rpm  
 $J$  Total moment of inertia in  $\text{kgm}^2$

- The braking energy in Nm against a load torque:

$$Q_L = \frac{\pm T_L \cdot n_{rated} \cdot t_{Br}}{19.1}$$

- $T_L$  average load torque in Nm  
 $T_L$  is positive if it acts against the brake  
 $T_L$  is negative if it supports the brake

##### Run-on revolutions $U$

The number of run-on revolutions  $U$  of the motor with brake can be calculated as follows:

$$U = \frac{n_{rated}}{60} \left( t_2 + \frac{t_{Br}}{2} \right)$$

- $t_2$  Brake application time in ms

##### Lifetime of the brake lining $L$ and readjustment of the air gap

The brake lining wears due to friction which increases the air gap and the release time for the brake at standard excitation.

When the brake lining is worn out, it can be replaced easily.

In order to calculate the lifetime of the brake lining in terms of operations  $S_{max}$ , then the lifetime of the brake lining  $L$  in Nm must be divided by the braking energy  $Q_{adm}$ :

$$S_{max} = \frac{L}{Q_{adm}}$$

The interval between adjustments  $N$  in can be calculated in terms of operations by dividing the braking energy  $L_N$  which the brake can output until it is necessary to readjust the working air gap by  $Q_{adm}$ :

$$N = \frac{L_N}{Q_{adm}}$$

# IEC Squirrel-Cage Motors

## Introduction motors 1LA, 1LG, 1LL, 1LP, 1MA, 1MJ, 1PP, 1PQ

### General technical data

0

#### Additional versions

Depending on the selected motor, brake types 2LM8 or KFB are used.

2LM8 spring-operated disk brake	KFB spring-operated brake
<b>Motor series</b>	
This brake is mounted on 1LA5 and 1LA7 motors in the frame sizes 63 to 225 and on 1LG motors in the frame sizes 180 to 225 as standard.	This brake is the standard brake for 1LG motors in frame sizes 250 to 315.
<b>Voltage and frequency</b>	
The solenoids and the rectifiers of the brakes are designed for connection to the following voltages: 1 AC 50 Hz 230 V $\pm 10\%$ or 1 AC 60 Hz 230 V $\pm 10\%$	The solenoids and the rectifiers of the brakes are designed for connection to the following voltages: 1 AC 50 Hz 230 V $\pm 10\%$
<b>When 60 Hz is used, the voltage for the brake must not be increased!</b>	<b>When 60 Hz is used, the voltage for the brake must not be increased!</b>
The brake can also be supplied for other voltages:	The brake can also be supplied for other voltages:
<ul style="list-style-type: none"> <li>Brake supply voltage: 24 V DC Order code <b>C00</b></li> <li>Brake supply voltage: 400 V AC (directly at the terminal strip) Order code <b>C01</b></li> <li>Brake supply voltage: 180 V DC, for operation on MM411 ECOFAST (directly at the terminal strip) Order code <b>C02</b></li> </ul>	<ul style="list-style-type: none"> <li>Brake supply voltage: 24 V DC Order code <b>C00</b></li> <li>Brake supply voltage: 400 V AC (directly at the terminal strip) Order code <b>C01</b></li> </ul>
Order codes <b>C00</b> , <b>C01</b> and <b>C02</b> may only be used in conjunction with order code <b>G26</b> .	The codes <b>C00</b> and <b>C01</b> may only be used in conjunction with Code <b>G26</b> .
<b>Connections</b>	
Labeled terminals are provided in the main connection box of the motor to connect the brake.	The motors are equipped with an additional connection box on the side of the main connection box that is used specifically for connection of the brake. KFB brakes are connected through a standard bridge or half-wave rectifier. See the circuit diagrams below.
The AC voltage for the brake excitation winding is connected to the two free terminals of the rectifier block (~).	A special circuit is not required. Optimal switching times are achieved without the need to use special circuits.
The brake can be released when the motor is at a standstill by separately exciting the solenoid. In this case, an AC voltage must be connected at the rectifier block terminals. The brake remains released as long as this voltage is present.	
The rectifier is protected against overvoltages by varistors in the input and output circuits.	
For 24 V DC brakes, the brake terminals are directly connected to the DC voltage source.	
See the circuit diagrams below.	
<b>Fast brake application</b>	
If the brake is disconnected from the line supply, the brake is applied. The application time for the brake disk is delayed as a result of the inductance of the solenoid (shutdown on the AC side). This results in a considerable delay before the brake is mechanically applied. In order to achieve short brake application times, the circuit must be interrupted on the DC side. To realize this, the wire jumpers, located between contacts 1+ and 2+ at the rectifier are removed and replaced by the contact of an external switch (see circuit diagrams below).	Not available for the KFB brake.
For 1LG motors with a 2LM8 brake, "Fast application of the brake" is not possible in the standard version. Please contact your local Siemens office for advice.	
<b>Manual brake release with lever</b>	
The brakes can be supplied with a mechanical manual release with lever. Order code <b>K82</b> .	The brake can be released manually with screws as standard. Mechanical manual release with a lever can be ordered with Order code <b>K82</b> .
The dimensions of the brake lever depend on the motor frame size and can be read from the dimension drawing generator for motors in the SD configurator tool for low-voltage motors.	The dimensions of the brake lever depend on the motor frame size and can be read from the dimension drawing generator for motors in the SD configurator tool for low-voltage motors.

#### Bridge rectifier / half-wave rectifier

Brakes are connected through a standard bridge or half-wave rectifier or directly to the 2LM8 or KFB brake. See the circuit diagrams below.

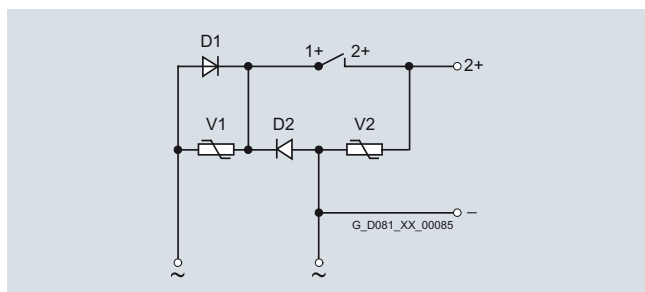

Half-wave rectifier 400 V AC

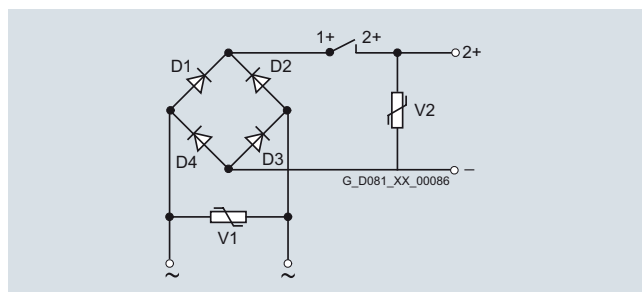

Bridge rectifier, 230 V AC

# IEC Squirrel-Cage Motors

## Introduction motors 1LA, 1LG, 1LL, 1LP, 1MA, 1MJ, 1PP, 1PQ

### General technical data

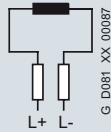

Brake connection for 24 V DC

#### Combinations of basic versions

The following combinations of modular technology can be supplied by the factory when ordered using the predefined order codes:

##### Mounting of brake <sup>1)</sup> and 1XP8 001 rotary pulse encoder

The brake (order code G26) and the rotary pulse encoder 1XP8 001-1 HTL (order code H57) can be supplied already mounted in combination.

Order code **H62**.

The brake (order code G26) and the rotary pulse encoder 1XP8 001-2 TTL (order code H58) can be supplied already mounted in combination.

Order code **H98**.

##### Mounting of separately driven fan and 1XP8 001 rotary pulse encoder

The separately driven fan (order code G17) and the rotary pulse encoder 1XP8 001-1 HTL (order code H57) can be supplied already mounted in combination.

Order code **H61**.

The separately driven fan (order code G17) and the rotary pulse encoder 1XP8 001-2 TTL (order code H58) can be supplied already mounted in combination.

Order code **H97**.

##### Mounting of brake <sup>1)</sup> and separately driven fan

The brake (order code G26) and separately driven fan (order code G17) can be supplied already mounted in combination.

Order code **H63**.

##### Mounting of brake, <sup>1)</sup> separately driven fan and 1XP8 001 rotary pulse encoder

The brake (order code G26), the separately driven fan (order code G17) and the rotary pulse encoder 1XP8 001-1 HTL (order code H57) can be supplied already mounted in combination.

Order code **H64**.

The brake (order code G26), the separately driven fan (order code G17) and the rotary pulse encoder 1XP8 001-2 TTL (order code H58) can be supplied already mounted in combination.

Order code **H99**.

When a rotary pulse encoder, brake or separately driven fan is mounted, the length of the motor increases by  $\Delta l$ . For an explanation of the additional dimensions and weights, see "Technology", "Dimensions and weights".

<sup>1)</sup> The spring-operated brake 2LM8 (see from Page 0/77) is mounted as standard on 1LA5 and 1LA7 motors in the frame sizes 63 to 225 and on 1LG motors in frame sizes 180 to 225. For 1LG motors in the frame sizes 250 to 315 the spring-operated brake KFB is the standard brake (see from Page 0/80).

**Special technology****Prepared for mounting MICROMASTER Integrated (MMI)**

Converter mounting is possible for motor series 1LA7 frame sizes 56 to 132 for 230 V $\Delta$ /400 VY if the MICROMASTER DA 51.3 type is specified. Not possible for motors with special insulation for 690 V.

Order code **H15**

**Brake (specially for 1LA8 and 1PQ8 motor series)**

For motor series 1LA8 and 1PQ8, a solenoid double-disk spring-operated brake of type NFA (from Stromag) can be supplied at the drive end (DE). The brake can only be used as a holding brake. See the table below for values for the holding brake torque.

Order code **H47**, price on request

For motors	Brake size	Holding brake torque $T_H$
<b>1LA8, 1PQ8</b>	NFA	Nm
<b>31 .</b>	160/250	2500
<b>35 .</b>	160/250	2500
	250/400	4000
<b>40 .</b>	250/400	4000
	400/630	6300
<b>45 .</b>	400/630	6300
	630/1000	10000

When a brake is mounted, the length of the motor increases by  $\Delta$  l. For an explanation of the additional dimensions and weights, see "Technology", "Dimensions and weights".

The brake is generally procured and mounted by the factory.

Further information is available on request.

The "Special technology" comprises rotary pulse encoders for frame sizes 100 L to 450 of 1LA5, 1LA6, 1LA7, 1LA8 and 1LG4/6 motors. Please inquire about the specified rotary pulse encoders for 1LA9 motors.

The order codes listed under "Special technology" cannot be combined in the case of 1LA motors with order codes from the modular technology range.

For 1LG motors, order codes **G17** (mounting of separately driven fan), **G26** (mounting of brake) and **H63** (mounting of brake and separately driven fan) from the modular technology range can be combined with the "Special technology" rotary pulse encoders.

When a rotary pulse encoder is mounted, the length of the motor increases by  $\Delta$  l. For an explanation of the additional dimensions and weights, see "Technology", "Dimensions and weights".

**LL 861 900 220 rotary pulse encoder**

With its rugged construction, this rotary pulse encoder is also suitable for difficult operating environments. It is resistant to shock and vibration and has insulated bearings.

The LL 861 900 220 rotary pulse encoder can be supplied already mounted.

Order code **H70**.

The LL 861 900 220 rotary pulse encoder can be retrofitted. The motor must be prepared for this. When the motor is ordered, order code **H78** must be specified. The rotary pulse encoder is not part of the scope of supply in this case. The mounting components required will be supplied. For motors in Zone 2 (Ex n), a special rotary pulse encoder can be supplied (please inquire).

The version of the rotary pulse encoder with a diagnostics system (ADS) can be supplied by Leine and Linde.

Manufacturer:

Leine and Linde (Germany) GmbH  
Bahnhofstraße 36  
73430 Aalen  
Tel. +49 (0)73 61-78093-0  
Fax +49 (0)73 61-78093-11

<http://www.leinelinde.com>

e-mail: [info@leinelinde.se](mailto:info@leinelinde.se)

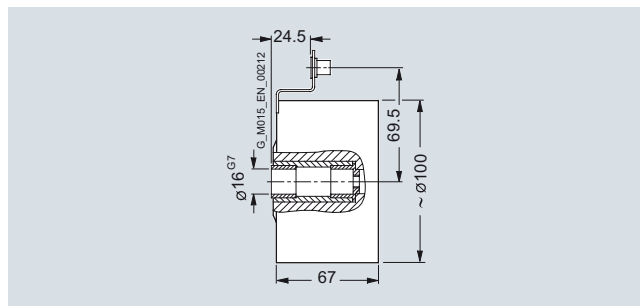

Mounting dimensions of LL 861 900 220 rotary pulse encoder

**Technical data for LL 861 900 220 (HTL version)**

Mounting of encoder at temperatures below  $-20$  °C and higher than  $+40$  °C on request.

Supply voltage $U_B$	9 V to +30 V
Current input without load	max. 80 mA
Admissible load current per output	40 mA
Pulses per revolution	1024
Outputs	6 short-circuit proof square-wave pulses A, A', B, B', 0, 0', High Current HTL
Pulse offset between the two outputs	$90^\circ \pm 25^\circ$ el.
Output amplitude	$U_{High} > U_B - 4$ V $U_{Low} < 2.5$ V
Mark space ratio	1:1 $\pm 10$ %
Edge steepness	50 V/ $\mu$ s (without load)
Maximum frequency	100 kHz for 350 m cable
Admissible speed	4000 rpm
Temperature range	$-20$ to $+80$ °C
Degree of protection	IP65
Admissible radial cantilever force	300 N
Admissible axial force	100 N
Termination system	Terminal strips in encoder, cable connection M20 x 1.5 radial
Weight	Approx. 1.3 kg

**Mounting a special type of rotary pulse encoder**

For motor series 1LA8, 1PQ8 and 1LL8, if the encoder designation is specified in the order, a special type of rotary pulse encoder can be supplied already mounted, provided the technical executability is given. In this case, the encoder is procured by the factory. When ordering, specify the rotary pulse encoder in plain text.

Order code **Y70**. Price and availability on request.

# IEC Squirrel-Cage Motors

## Introduction motors 1LA, 1LG, 1LL, 1LP, 1MA, 1MJ, 1PP, 1PQ

### General technical data

#### HOG9 D 1024 I rotary pulse encoder



The encoder is fitted with insulated bearings.

The HOG 9 D 1024 I rotary pulse encoder can be supplied already mounted.

Order code **H72**.

The HOG 9 D 1024 I rotary pulse encoder can be retrofitted. The motor must be prepared for this. When the motor is ordered, order code **H79** must be specified. The rotary pulse encoder is not part of the scope of supply in this case. The mounting components required will be supplied.

Manufacturer:

Baumer Hübner GmbH

Planufer 92b

10967 Berlin

Tel. +49 (0)30-6 90 03-0

Fax +49 (0)30-6 90 03-1 04

<http://www.baumerhuebner.com>

e-mail: [info@baumerhuebner.com](mailto:info@baumerhuebner.com)

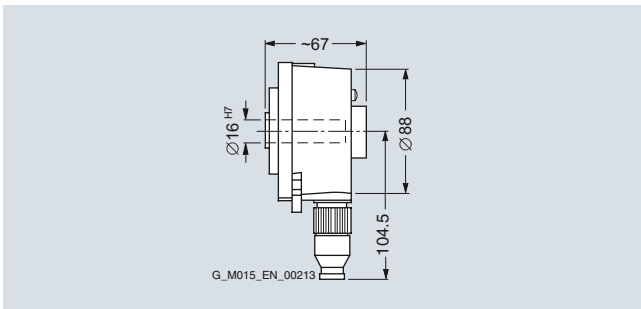

HOG 9 D 1024 I rotary pulse encoder

*Technical data for HOG 9 D 1024 I rotary pulse encoder (HTL version)*

Mounting of encoder at temperatures below  $-20\text{ °C}$  and higher than  $+40\text{ °C}$  on request.

<b>Supply voltage <math>U_B</math></b>	<b>+9 V to +30 V</b>
Current input without load	50 to 100 mA
Admissible load current per output	60 mA, 300 mA (peak)
Pulses per revolution	1024
Outputs	4 short-circuit proof square-wave pulses A, B and A', B'
Pulse offset between the two outputs	$90^\circ \pm 20\%$
Output amplitude	$U_{\text{High}} \geq U_B - 3.5\text{ V}$ $U_{\text{Low}} \leq 1.5\text{ V}$
Mark space ratio	$1:1 \pm 20\%$
Edge steepness	$10\text{ V}/\mu\text{s}$
Maximum frequency	120 kHz
Maximum speed	7000 rpm
Temperature range	$-30\text{ to }+100\text{ °C}$
Degree of protection	IP56
Admissible radial cantilever force	300 N
Admissible axial force	200 N
Termination system	Radial plug (mating connector is part of the scope of supply)
Mech. design acc. to Hübner Ident. No.	73 522 E
Weight	Approx. 0.7 kg



**HOG 10 D rotary pulse encoder**

This encoder is extremely rugged and is therefore suitable for difficult operating conditions. It is fitted with insulated bearings.

The HOG 10 D rotary pulse encoder can be supplied already mounted in different versions. The manufacturer is the same; only the technical data and the respective dimensions and weights change.

Mounting of encoder at temperatures below  $-20\text{ °C}$  and higher than  $+40\text{ °C}$  on request.

Manufacturer:  
Baumer Hübner GmbH  
Planufer 92b  
10967 Berlin  
Tel. +49 (0)30-6 90 03-0  
Fax +49 (0)30-6 90 03-1 04

<http://www.baumerhuebner.com>  
e-mail: [info@baumerhuebner.com](mailto:info@baumerhuebner.com)

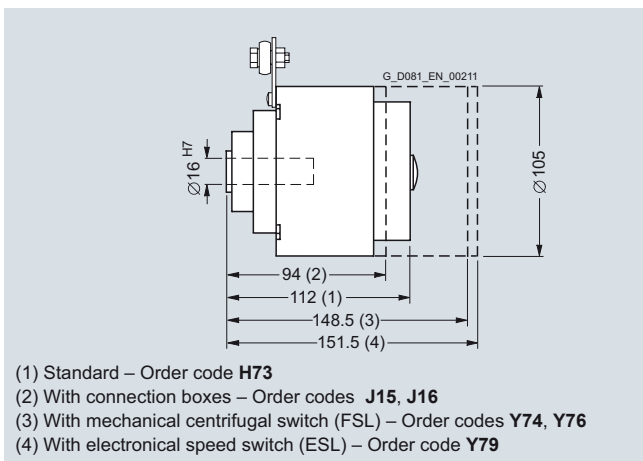

- (1) Standard – Order code **H73**  
 (2) With connection boxes – Order codes **J15, J16**  
 (3) With mechanical centrifugal switch (FSL) – Order codes **Y74, Y76**  
 (4) With electronic speed switch (ESL) – Order code **Y79**

HOG 10 D 1024 rotary pulse encoder

**HOG 10 D 1024 I rotary pulse encoder**

The rotary pulse encoder HOG 10 D 1024 I can be supplied already mounted.

Order code **H73**

The rotary pulse encoder HOG 10 D 1024 I can also be retrofitted to a motor prepared for this. When the motor is ordered, order code **H80** must be specified. The rotary pulse encoder is not part of the scope of supply in this case. The mounting components required will be supplied.

*Technical data for HOG 10 D 1024 I (HTL version)*

<b>Supply voltage <math>U_B</math></b>	<b>+9 V to +30 V</b>
Current input without load	Approx. 100 mA
Admissible load current per output	60 mA, 300 mA (peak)
Pulses per revolution	1024
Outputs	4 short-circuit proof square-wave pulses A, B and A', B'
Pulse offset between the two outputs	$90^\circ \pm 20\%$
Output amplitude	$U_{High} \geq U_B - 3.5\text{ V}$ $U_{Low} \leq 1.5\text{ V}$
Mark space ratio	1:1 $\pm 20\%$
Edge steepness	10 V/ $\mu$ s
Maximum frequency	120 kHz
Maximum speed	7000 rpm
Temperature range	$-40$ to $+100\text{ °C}$
Degree of protection	IP66
Admissible radial cantilever force	400 N
Admissible axial force	250 N
Termination system	Terminals, cable connection M20 x 1.5
Mech. design acc. to Hübner Ident. No.	74 055 E
Weight	Approx. 1.6 kg

**Rotary pulse encoder HOG 10 DN 1024 I, connection box protection against moisture**

The rotary pulse encoder HOG 10 DN 1024 I can be supplied with the already mounted connection box in version with protection against moisture (IP56).

Order code **J15**

*Technical data HOG 10 DN 1024 I (HTL version), connection box protection against moisture*

<b>Supply voltage <math>U_B</math></b>	<b>+9 V to +30 V</b>
Current input without load	Approx. 100 mA
Admissible load current per output	60 mA, 300 mA peak
Pulses per revolution	1024
Outputs	6 short-circuit proof square-wave pulses A, B and A', B', N, N'
Pulse offset between the two outputs	$90^\circ \pm 20\%$
Output amplitude	$U_{High} \geq U_B - 3.5\text{ V}$ $U_{Low} \leq 1.5\text{ V}$
Mark space ratio	1:1 $\pm 20\%$
Edge steepness	10 V/ $\mu$ s
Maximum frequency	120 kHz
Maximum speed	7000 rpm
Temperature range	$-40$ to $+100\text{ °C}$
Degree of protection	IP66
Max. admissible radial cantilever force	400 N
Max. admissible axial force	250 N
Termination system	Terminals, cable connection M20 x 1.5
Mech. design acc. to Hübner Ident. No.	74 007E-HOG10
Weight	Approx. 1.6 kg

# IEC Squirrel-Cage Motors

## Introduction motors 1LA, 1LG, 1LL, 1LP, 1MA, 1MJ, 1PP, 1PQ

### General technical data

#### Rotary pulse encoder HOG 10 DN 1024 I, connection box protection against dust

The rotary pulse encoder HOG 10 DN 1024 I can be supplied with the already mounted connection box in version with protection against dust (IP65).

Order code **J16**

*Technical data HOG 10 DN 1024 I (HTL version), connection box protection against dust*

Supply voltage $U_B$	+9 V to +30 V
Current input without load	Approx. 100 mA
Admissible load current per output	60 mA, 300 mA peak
Pulses per revolution	1024
Outputs	6 short-circuit proof square-wave pulses A, B and A', B', N, N'
Pulse offset between the two outputs	90° ±20 %
Output amplitude	$U_{High} \geq U_B - 3.5 V$ $U_{Low} \leq 1.5 V$
Mark space ratio	1:1 ±20 %
Edge steepness	10 V/μs
Maximum frequency	120 kHz
Maximum speed	7000 rpm
Temperature range	-40 to +100 °C
Degree of protection	IP66
Max. admissible radial cantilever force	400 N
Max. admissible axial force	250 N
Termination system	Terminals, cable connection M20 x 1.5
Mech. design acc. to Hübner Ident. No.	74 006E-HOG10
Weight	Approx. 1.6 kg

#### Rotary pulse encoder HOG 10 DN 1024 I + FSL, (speed ... rpm), connection box protection against moisture

The rotary pulse encoder HOG 10 DN 1024 I can be supplied with the already mounted connection box in version with protection against moisture (IP56) and mechanical centrifugal switch (FSL).

An operating speed of the centrifugal switch within the admissible range must be specified in plain text, see technical data of the rotary pulse encoder.

Order code **Y74**

*Technical data HOG 10 DN 1024 I (HTL version) + FSL, (speed .... rpm), connection box protection against moisture*

Supply voltage $U_B$	+9 V to +30 V
Current input without load	Approx. 100 mA
Admissible load current per output	60 mA, 300 mA peak
Pulses per revolution	1024
Outputs	6 short-circuit proof square-wave pulses A, B and A', B', N, N'
Pulse offset between the two outputs	90° ±20 %
Output amplitude	$U_{High} \geq U_B - 3.5 V$ $U_{Low} \leq 1.5 V$
Mark space ratio	1:1 ±20 %
Edge steepness	10 V/μs
Maximum frequency	120 kHz
Maximum speed	7000 rpm
Temperature range	-40 to +100 °C
Degree of protection	IP66
Max. admissible radial cantilever force	400 N
Max. admissible axial force	250 N
<b>Centrifugal switch</b>	
Operating speed	850 ... 4900 rpm
Maximum speed	1.25 x n
Differential gap, clockwise/counter-clockwise	≈ 3 %
Speed hysteresis	≈ 40 %
Switching capacity	6 A/230 V AC; 1 A 125 V DC
Termination system	Terminals, cable connection M20 x 1.5 + M20 x 1.5
Mech. design acc. to Hübner Ident. No.	74 035F-HOG10
Weight	Approx. 2.1 kg

**Rotary pulse encoder HOG 10 DN 1024 I + FSL, connection box protection against dust**

The rotary pulse encoder HOG 10 DN 1024 I can be supplied with the already mounted connection box in version with protection against dust (IP65) and mechanical centrifugal switch (FSL). An operating speed of the centrifugal switch within the admissible range must be specified in plain text, see technical data of the rotary pulse encoder.

Order code **Y76**

*Technical data HOG 10 DN 1024 I (HTL version +) + FSL, (speed .... rpm), connection box protection against dust*

Supply voltage $U_B$	+9 V to +30 V
Current input without load	Approx. 100 mA
Admissible load current per output	60 mA, 300 mA peak
Pulses per revolution	1024
Outputs	6 short-circuit proof square-wave pulses A, B and A', B', N, N'
Pulse offset between the two outputs	90° ±20 %
Output amplitude	$U_{High} \geq U_B - 3.5 V$ $U_{Low} \leq 1.5 V$
Mark space ratio	1:1 ±20 %
Edge steepness	10 V/μs
Maximum frequency	120 kHz
Maximum speed	7000 rpm
Temperature range	-40 to +100 °C
Degree of protection	IP66
Max. admissible radial cantilever force	400 N
Max. admissible axial force	250 N
<b>Centrifugal switch</b>	
Operating speed	850 ... 4900 rpm
Maximum speed	1.25 x n
Differential gap, clockwise/counter-clockwise	≈ 3 %
Speed hysteresis	≈ 40 %
Switching capacity	6 A/230 V AC; 1 A 125 V DC
Termination system	Terminals, cable connection M20 x 1.5 + M20 x 1.5
Mech. design acc. to Hübner Ident. No.	74 022F-HOG10
Weight	Approx. 2.1 kg

**Rotary pulse encoder HOG 10 DN 1024 I + ESL 93, (speed ... rpm), connection box protection against dust**

The rotary pulse encoder HOG 10 DN 1024 I can be supplied with the already mounted connection box in version with protection against dust (IP65) and electronic speed switch (ESL). One up to three operating speeds of the electronic switch within the admissible range must be specified in plain text, see technical data of the rotary pulse encoder.

Order code **Y79**

*Technical data HOG 10 DN 1024 I (HTL version) + ESL 93, (speed .... rpm), connection box protection against dust*

Supply voltage $U_B$	+9 V to +30 V
Current input without load	Approx. 100 mA
Admissible load current per output	60 mA, 300 mA peak
Pulses per revolution	1024
Outputs	6 short-circuit proof square-wave pulses A, B and A', B', N, N'
Pulse offset between the two outputs	90° ±20 %
Output amplitude	$U_{High} \geq U_B - 3.5 V$ $U_{Low} \leq 1.5 V$
Mark space ratio	1:1 ±20 %
Edge steepness	10 V/μs
Maximum frequency	120 kHz
Maximum speed	7000 rpm
Temperature range	-40 to +100 °C
Degree of protection	IP66
Max. admissible radial cantilever force	400 N
Max. admissible axial force	250 N
<b>Electronical switch</b>	
Operating speed	3 x 200 ... 5000 rpm
Maximum speed	6000 rpm
Switching accuracy	± (2-4) %
Switching capacity	3 x 49 mADC
With relay module (external relay module required!)	3 x 6 A/230 V AC; 1 A 125 V DC
Differential gap, clockwise/counter-clockwise	≈ 3 %
Speed hysteresis	max. 30 %
Principle	Electronics
Auxiliary power	12 V/5 mA
Termination system	Terminals, cable connection M20 x 1.5 + M20 x 1.5
Mech. design acc. to Hübner Ident. No.	74 031E-HOG10
Weight	Approx. 2.9 kg

# IEC Squirrel-Cage Motors

## Introduction motors 1LA, 1LG, 1LL, 1LP, 1MA, 1MJ, 1PP, 1PQ

### General technical data

0

#### Dimensions and weight

**Fig. 1** Brake  
Order code **G26**  
[optionally with manual release, order code **K82**]

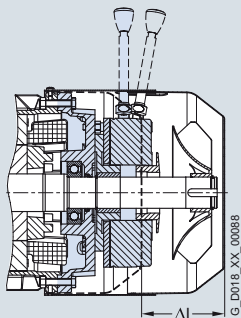

**Fig. 2** Brake for 1LA8 and 1PQ8 motor series at drive end (DE)  
Order code **H47**

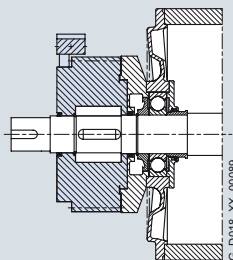

**Fig. 3** Rotary pulse encoders (on cover)  
Order codes **H57, H58, H70, H72, H73, (H78), (H79), (H80), J15, J16, Y74, Y76, Y79**

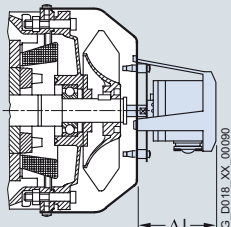

**Fig. 4** Brake and rotary pulse encoder (on cover) 1XP8 001  
Order codes **H62, H98**  
[optionally with manual release, order code **K82**]

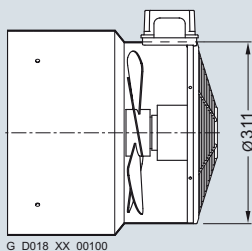
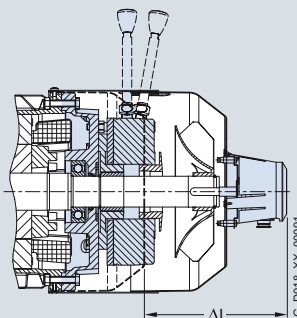

For motor series 1LA5 frame sizes 180 to 225 with separately driven fan, the fan attachment becomes narrower on the non-drive end (NDE) of the motor housing.

# IEC Squirrel-Cage Motors

## Introduction motors 1LA, 1LG, 1LL, 1LP, 1MA, 1MJ, 1PP, 1PQ

General technical data

0

1LA frame sizes 100 to 225,  
1LG frame sizes 180 and 200

1LG frame size 225 and above

**Fig. 5** Separately driven fan  
Order code **G17**

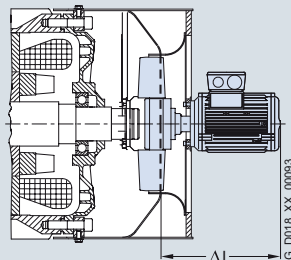
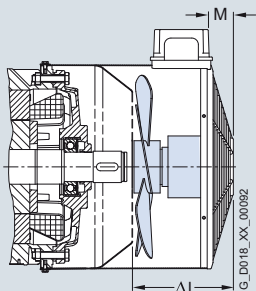

**Fig. 6** Brake and separately driven fan  
Order code **H63**  
[optionally with manual release **K82**]

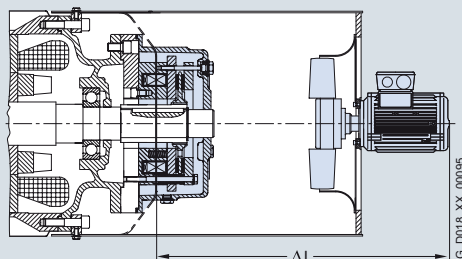
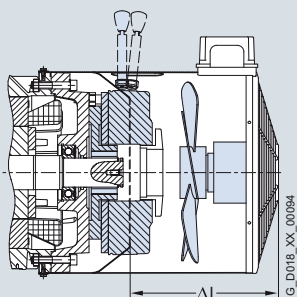

**Fig. 7** Rotary pulse encoder (under cover) 1XP8 001 and separately driven fan  
Order codes **H61, H97**

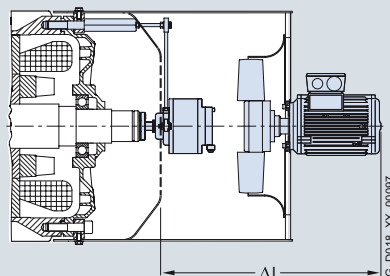
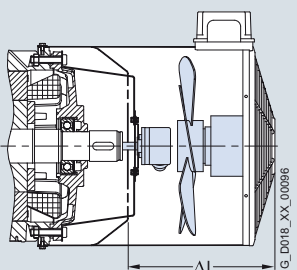

**Fig. 8** Brake, rotary pulse encoder (under cover) 1XP8 001 and separately driven fan  
Order codes **H64, H99**  
[optionally with manual release (**K82**)]

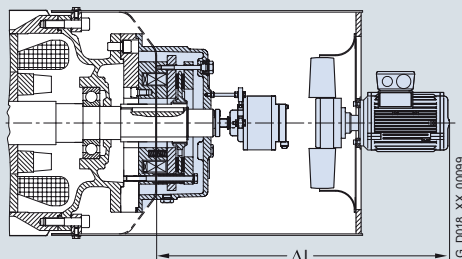
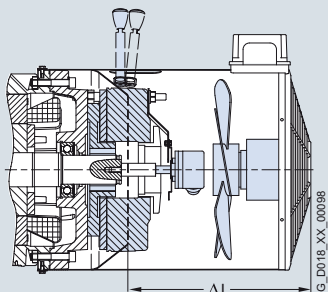

# IEC Squirrel-Cage Motors

## Introduction motors 1LA, 1LG, 1LL, 1LP, 1MA, 1MJ, 1PP, 1PQ

### General technical data

Frame size	Assignment																	
	Fig. 1		Fig. 2		Fig. 3													
	Brake		Brake		Pulse encoder													
					1XP8 001		LL 861 900220		HOG9 D 1024 I		HOG10 D 1024 I							
Order code G26		Order code H47		Order code H57, H58		Order codes H70		Order codes H72		Order codes H73		J15, J16		Y74, Y76		Y79		
Δl	Weight approx.	Δl	Weight approx.	Δl	Weight approx.	Δl	Weight approx.	Δl	Weight approx.	Δl	Weight approx.	Δl	Weight approx.	Δl	Weight approx.	Δl	Weight approx.	
mm	kg	mm	kg	mm	kg	mm	kg	mm	kg	mm	kg	mm	kg	mm	kg	mm	kg	
<b>1LA7, 1LA5</b>																		
63	51	1	-	-	-	-	-	-	-	-	-	-	-	-	-	-	-	
71	51	1	-	-	-	-	-	-	-	-	-	-	-	-	-	-	-	
80	54	2	-	-	-	-	-	-	-	-	-	-	-	-	-	-	-	
90	75	4	-	-	-	-	-	-	-	-	-	-	-	-	-	-	-	
100	78	6	-	-	78	0.3	91	1.3	89	0.9	134	1.6	-	-	-	-	-	
112	87	8	-	-	78	0.3	91	1.3	89	0.9	134	1.6	-	-	-	-	-	
132	106	12	-	-	78	0.3	91	1.3	89	0.9	134	1.6	-	-	-	-	-	
160	129	26	-	-	78	0.3	91	1.3	89	0.9	134	1.6	-	-	-	-	-	
180	137	27	-	-	78	0.3	91	1.3	89	0.9	134	1.6	-	-	-	-	-	
200	142	41	-	-	78	0.3	91	1.3	89	0.9	134	1.6	-	-	-	-	-	
225	142	41	-	-	78	0.3	91	1.3	89	0.9	134	1.6	-	-	-	-	-	
<b>1LA6</b>																		
100	-	-	-	-	78	0.3	91	1.3	89	0.9	134	1.6	116	1.6	-	-	-	
112	-	-	-	-	78	0.3	91	1.3	89	0.9	134	1.6	116	1.6	-	-	-	
132	-	-	-	-	78	0.3	91	1.3	89	0.9	134	1.6	116	1.6	-	-	-	
160	-	-	-	-	78	0.3	91	1.3	89	0.9	134	1.6	116	1.6	-	-	-	
<b>1LG4, 1LG6</b>																		
180	125	22	-	-	63	0.3	86	1.3	72	0.9	116	1.6	98	1.6	153	2.1	156	2.9
200	137	32	-	-	63	0.3	86	1.3	72	0.9	116	1.6	98	1.6	153	2.1	156	2.9
225	239	63	-	-	63	0.3	86	1.3	72	0.9	116	1.6	98	1.6	153	2.1	156	2.9
250	225	83	-	-	63	0.3	86	1.3	72	0.9	116	1.6	98	1.6	153	2.1	156	2.9
280	227	118	-	-	63	0.3	86	1.3	72	0.9	116	1.6	98	1.6	153	2.1	156	2.9
315	265	255	-	-	63	0.3	86	1.3	72	0.9	116	1.6	98	1.6	153	2.1	156	2.9
<b>1LA8, 1PQ8</b>																		
315	-	-	205	120	-	-	125	1.3	-	-	125	1.6	-	-	-	-	-	
355	-	-	225	165	-	-	125	1.3	-	-	125	1.6	-	-	-	-	-	
400	-	-	251	220	-	-	125	1.3	-	-	125	1.6	-	-	-	-	-	
450	-	-	270	325	-	-	125	1.3	-	-	125	1.6	-	-	-	-	-	
<b>1LL8</b>																		
315	-	-	-	-	-	-	125	1.3	-	-	125	1.6	-	-	-	-	-	
355	-	-	-	-	-	-	125	1.3	-	-	125	1.6	-	-	-	-	-	
400	-	-	-	-	-	-	125	1.3	-	-	125	1.6	-	-	-	-	-	
450	-	-	-	-	-	-	125	1.3	-	-	125	1.6	-	-	-	-	-	

# IEC Squirrel-Cage Motors

## Introduction motors 1LA, 1LG, 1LL, 1LP, 1MA, 1MJ, 1PP, 1PQ

### General technical data

Frame size	Assignment											
	Fig. 4		Fig. 5			Fig. 6		Fig. 7		Fig. 8		Diameter of the fan cowl
	Brake and rotary pulse encoder (on cowl) <b>1XP8 001</b>		Separately driven fan <sup>1)</sup>			Brake and separately driven fan <sup>1)</sup>		Rotary pulse encoder (under the cowl) <b>1XP8 001</b> and separately driven fan <sup>1)</sup>		Brake, rotary pulse encoder (under the cowl) <b>1XP8 001</b> and separately driven fan <sup>1)</sup>		
	Order codes <b>H62, H98</b>		Order code <b>G17</b>			Order code <b>H63</b>		Order codes <b>H61, H97</b>		Order codes <b>H64, H99</b>		
	$\Delta l$	Weight, approx.	$\Delta l$	M	Weight, approx.	$\Delta l$	Weight, approx.	$\Delta l$	Weight, approx.	$\Delta l$	Weight, approx.	
	mm	kg	mm	mm	kg	mm	kg	kg	kg	mm	kg	mm
<b>1LA7, 1LA5</b>												
63	–	–	–	–	–	–	–	–	–	–	–	–
71	–	–	–	–	–	–	–	–	–	–	–	–
80	–	–	–	–	–	–	–	–	–	–	–	–
90	–	–	–	–	–	–	–	–	–	–	–	–
100	156	6.3	141	30	4.0	141	10.0	226	4.3	226	10.3	202
112	165	8.3	158	30	4.5	158	12.5	226	4.8	226	12.8	227
132	184	12.3	177	40	5.5	177	17.5	247	5.8	247	17.8	226
160	207	26.3	227	40	7.0	227	33.0	289	7.3	289	33.3	320
180	215	27.3	269	40	10.0	269	37.0	269	10.3	269	37.3	311 (358)
200	220	41.3	272	40	11.0	272	52.0	272	11.3	272	52.3	311 (398)
225	220	41.3	272	40	11.0	272	52.0	272	11.3	272	52.3	311 (398)
<b>1LA6</b>												
100	–	–	141	30	4.0	–	–	226	4.3	–	–	202
112	–	–	158	30	4.5	–	–	226	4.8	–	–	227
132	–	–	177	40	5.5	–	–	247	5.8	–	–	226
160	–	–	227	40	7.0	–	–	289	7.3	–	–	320
<b>1LG4, 1LG6</b>												
180	203	22.3	269	40	10.0	269	32	269	10.3	269	32.3	356
200	215	32.3	272	40	11.0	272	43	272	11.3	272	43.3	396
225	317	63.3	235	0	22.0	576	85	425	22.3	576	85.3	439
250	303	83.3	235	0	25.0	578	108	425	25.3	578	108.3	489
280	305	118.3	235	0	28.0	550	146	425	28.3	550	146.3	539
315	343	255.3	247	0	36.0	577	291	437	36.3	577	291.3	604

The values in brackets ( ) refer to the diameter of the motor flange because this is larger than the diameter of the fan cowl (see figure on Page 0/90).

<sup>1)</sup> For frame sizes 100 to 200 and for 1LA5 up to frame size 225, the dimensions of the connection box for the separately driven fan, length x width x height, are 95 mm x 105 mm x 54 mm. For motor series 1LG4/1LG6 (frame sizes 225 to 315), the dimensions of the connection box for the separately driven fan, length x width x height, are 75 mm x 75 mm x 38 mm.

# IEC Squirrel-Cage Motors

## Introduction motors 1LE1, 1PC1

### Order No. code

0

#### Overview

The order number consists of a combination of figures and letters and is divided into three blocks linked with hyphens for a better overview, e.g.

**1LE1001-1DB20-1AA5-Z  
H00**

The first block (Positions 1 to 7) identifies the motor type; the second block (Positions 8 to 12) defines the motor frame size and length, the number of poles and in some cases the frequency/output; and in the third block (Positions 13 to 16), the frequency/output, type of construction and other design features are encoded.

For deviations in the second and third block from the catalog codes, either **-Z** or **9** should be used as appropriate.

#### Ordering data:

- Complete Order No. and order code(s) or plain text.
- If a quotation has been requested, please specify the quotation number in addition to the Order No.
- When ordering a complete motor as a spare part, please specify the works serial No. for the previously supplied motor as well as the Order No.

Structure of the Order No.:		Position:	1	2	3	4	5	6	7	-	8	9	10	11	12	-	13	14	15	16	
<b>IEC squirrel-cage motors, surface-cooled</b>																					
<b>Positions 1 to 4:</b> Digit, letter, letter, digit	<b>New generation</b> Design or version (motor type)		1	L	E	1															
	<ul style="list-style-type: none"> <li>• Standard: Self-ventilated by fan mounted on and driven by rotor</li> <li>• Expansion option (F90): Forced-air cooled by air flow from the fan to be driven</li> <li>• Special: Self-cooled without external fan and fan cover</li> </ul>																				
<b>Positions 5 to 7:</b> 3 digits	<ul style="list-style-type: none"> <li>• Motors with high efficiency (High Efficiency, EFF1), aluminum housing</li> <li>• Motors with improved efficiency (Improved Efficiency, EFF2), aluminum housing</li> </ul>						0	0	1												
<b>Positions 8, 9 and 11:</b> Digit, letter, digit	<b>Motor frame size</b> (frame size as a combination of shaft height and overall length, encoded)										1	A ... D	0 ... 6								
<b>Position 10:</b> Letter	<b>Number of poles</b> A ... D = 2-, 4-, 6-, 8-pole												A ... D								
<b>Positions 12 and 13:</b> 2 digits	<b>Voltage, circuit and frequency</b>														0 ... 9		0 ... 8				
<b>Position 14:</b> Letter	<b>Type of construction</b> (A – V)																	A ... V			
<b>Position 15:</b> Letter	<b>Motor protection</b> (A – Z; special versions encoded)																		A ... Z		
<b>Position 16:</b> Digit	<b>Mechanical design (motor version and connection box position)</b>																			0	
	<ul style="list-style-type: none"> <li>• <b>General Line motors with shorter delivery times, limited options</b> (connection box on top, cast feet, only basic versions possible, non-drive-end (NDE) cannot be modified)</li> <li>• <b>All options are possible or can be modified</b> <ul style="list-style-type: none"> <li>- Connection box on top</li> <li>- Connection box on RHS (viewed from DE)</li> <li>- Connection box on LHS (viewed from DE)</li> <li>- Connection box below</li> </ul> </li> </ul>																			4 5 6 7	
	Special order versions: encoded – additional order code required not encoded – additional plain text required																				- Z

#### Ordering example

Selection criteria	Requirement	Structure of the Order No.
Motor type	New generation Standard motor with high efficiency EFF1, IP55 degree of protection, aluminum version	<b>1LE1001-□□□□□□-□□□□□</b>
Motor frame size/No. of poles/speed	160/4-pole/1500 rpm	<b>1LE1001-1DB2□-□□□□□</b>
Rated output	11 kW	
Voltage and frequency	230 VΔ/400 VY, 50 Hz	<b>1LE1001-1DB22-2□□□□</b>
Type of construction	IM V5 with protective cover <sup>1)</sup>	<b>1LE1001-1DB22-2C□□□-Z H00</b>
(Special versions)	3 PTC thermistors (motor protection with 3 embedded temperature sensors for tripping <sup>2)</sup> )	<b>1LE1001-1DB22-2CB□□-Z H00</b>
Mechanical design (motor version)	Connection box on RHS (viewed from DE)	<b>1LE1001-1DB22-2CB5-Z H00</b>
	Mounted separately driven fan	<b>1LE1001-1DB22-2CB5-Z H00 F70</b>

<sup>1)</sup> Standard without protective cover – the protective cover is defined with option **H00** and this option must be ordered in addition.

<sup>2)</sup> No additional option must be specified in the order.



# IEC Squirrel-Cage Motors

## Introduction motors 1LE1, 1PC1

Special versions

0

### Overview

The order codes and availability are assigned to the individual motor series in the "Selection and ordering data" in catalog part 1.

For

- Voltages
- Types of constructions
- Motor protection
- Motor connection and connection box

see the relevant heading in section "General technical data" in this catalog part.

All available options are listed according to topics in the following table. An alphanumerical listing according to order codes can be found in the appendix under "Overview of order codes".

### Attention:

For 1LE1 and 1PC1 motors apply only the "Special versions" of the following table and of catalog part 1. Motor protection and motor connection or connection box can be defined as Order No. supplement with the positions 15 or 16 of the Order No.

Order code	Special versions	For further information, see Page
<b>Motor connection and connection box</b>		
R15	One cable gland, metal	0/114
R10	Rotation of the connection box through 90°, entry from DE	0/114
R11	Rotation of the connection box through 90°, entry from NDE	0/114
R12	Rotation of the connection box through 180°	0/114
R50	<i>New!</i> Larger connection box	0/113
R30	<i>New!</i> Reduction piece for M cable gland in accordance with British standard, both cable entries mounted	0/114
H04	External earthing	0/113
R20	<i>New!</i> 3 cables protruding, 0.5 m long	0/114
R21	<i>New!</i> 3 cables protruding, 1.5 m long	0/114
R22	<i>New!</i> 6 cables protruding, 0.5 m long	0/114
R23	<i>New!</i> 6 cables protruding, 1.5 m long	0/114
R24	<i>New!</i> 6 cables protruding, 3 m long	0/114
H08	<i>New!</i> Connection box on NDE	0/113
<b>Windings and insulation</b>		
N01	Temperature class 155 (F), used acc. to 155 (F), with service factor (SF)	0/108
N02	Temperature class 155 (F), used acc. to 155 (F), with increased output	0/108
N03	Temperature class 155 (F), used acc. to 155 (F), with increased coolant temperature	0/108
N11	<i>New!</i> Temperature class 180 (H) at rated power and max. CT 60 °C	0/108
N20	<i>New!</i> Increased air humidity/temperature with 30 to 60 g water per m <sup>3</sup> of air	0/108
N05	Temperature class 155 (F), used acc. to 130 (B), coolant temperature 45 °C, derating approx. 4 %	0/108
N06	Temperature class 155 (F), used acc. to 130 (B), coolant temperature 50 °C, derating approx. 8 %	0/108
N07	Temperature class 155 (F), used acc. to 130 (B), coolant temperature 55 °C, derating approx. 13 %	0/108
N08	Temperature class 155 (F), used acc. to 130 (B), coolant temperature 60 °C, derating approx. 18 %	0/108
N21	<i>New!</i> Increased air humidity/temperature with 60 to 100 g water per m <sup>3</sup> of air	0/108
Y52	Temperature class 155 (F), used acc. to 155 (F), other requirements	0/108
<b>Colors and paint finish</b>		
Y54	Special finish in other standard RAL colors	0/101
Y51	Special finish in special RAL colors	0/101
S03	<i>New!</i> Special finish sea air resistant	0/100
S00	Unpainted (only cast iron parts primed)	0/100
S01	Unpainted, only primed	0/100
<b>Modular technology – Basic versions</b>		
F70	Mounting of separately driven fan	0/129
F01	Mounting of brake	0/130 ...
G01	Mounting of 1XP8012-10 (HTL) rotary pulse encoder	0/128
G02	Mounting of 1XP8012-20 (TTL) rotary pulse encoder	0/128
<b>Modular technology – Additional versions</b>		
F10	Brake supply voltage 24 V DC	0/133
F11	Brake supply voltage 230 V AC, 50/60 Hz	0/133
F12	Brake supply voltage 400 V AC, 50/60 Hz	0/133
F50	Mechanical manual brake release with lever (no locking)	0/133
<b>Special technology</b>		
G04	Mounting of LL 861 900 220 rotary pulse encoder	0/134
G05	Mounting of HOG 9 D 1024 I rotary pulse encoder	0/135
G06	Mounting of HOG 10 D 1024 I rotary pulse encoder	0/136

# IEC Squirrel-Cage Motors

## Introduction motors 1LE1, 1PC1

### Special versions

#### Overview "Special versions" (Fortsetzung)

Order code	Special versions	For further information, see Page
<b>Mechanical design and degrees of protection</b>		
H00	Protective cover for types of construction	0/119
H01	Screwed-on feet (instead of cast)	0/113
H23	<i>New!</i> Radial seal on DE for flange-mounting motors with oil resistance to 0.1 bar	0/118
F77	<i>New!</i> Low-noise version for 2-pole motors with clockwise direction of rotation	0/119
F78	<i>New!</i> Low-noise version for 2-pole motors with counter-clockwise direction of rotation	0/119
H20	<i>New!</i> IP65 degree of protection	0/119
H22	<i>New!</i> IP56 degree of protection (non-heavy-sea)	0/119
H02	<i>New!</i> Vibration-proof version	0/119
H03	Condensation drainage holes	0/119
H07	<i>New!</i> Non-rusting screws (externally)	0/119
G40	Prepared for mountings, only center hole	0/118
G41	Prepared for mountings with D12 shaft	0/118
G42	Prepared for mountings with D16 shaft	0/118
G43	<i>New!</i> Protective cover for encoder (loosely enclosed – only for mountings acc. to order codes G40, G41 and G42)	0/118
<b>Coolant temperature and site altitude</b>		
D03	<i>New!</i> Coolant temperature –40 °C to +40 °C	0/107
D04	<i>New!</i> Coolant temperature –30 °C to +40 °C	0/107
<b>Designs in accordance with standards and specifications</b>		
D30	<i>New!</i> Electrical according to NEMA MG1-12	0/99
D31	<i>New!</i> Design according to UL with "Recognition Mark"	0/99
D40	<i>New!</i> Canadian regulations (CSA)	0/98, 0/99
D46	<i>New!</i> PSE Mark Japan	0/99
<b>Bearings and lubrication</b>		
Q01	Measuring nipple for SPM shock pulse measurement for bearing inspection	0/122
L22	Bearing design for increased cantilever forces	0/122, 0/124 ...
L25	Special bearing for DE and NDE, bearing size 63	0/122, 0/124 ...
L23	Regreasing device	0/122
L20	Located bearing at DE	0/122
L21	Located bearing at NDE	0/122
<b>Balance and vibration quantity</b>		
L00	Vibration quantity level B	0/120
L02	Full-key balancing	0/120
L01	Balancing without fitted key	0/120
<b>Shaft and rotor</b>		
L08	Concentricity of shaft extension, coaxiality and linear movement in accordance with DIN 42955 Tolerance R for flange-mounting motors	0/121
L05	Second standard shaft extension	0/121
L04	<i>New!</i> Shaft extension with standard dimensions, without featherkey way	0/121
L07	Concentricity of shaft extension in accordance with DIN 42955 Tolerance R	0/121
L06	Standard shaft made of non-rusting steel	0/121
Y55	<i>New!</i> Non-standard cylindrical shaft extension	0/121
<b>Heating and ventilation</b>		
F75	<i>New!</i> Fan cover for textile industry	0/111
F76	<i>New!</i> Metal external fan	0/111
Q02	Anti-condensation heaters for 230 V	0/111
Q03	Anti-condensation heaters for 115 V	0/111
F74	Sheet metal fan cover	0/111
<b>Rating plate and extra rating plates</b>		
M10	Second rating plate, loose	0/106
M11	Nirosta rating plate	0/106
Y80	Extra rating plate or rating plate with deviating rating plate data	0/106
Y82	Extra rating plate with identification codes	0/106
Y84	Additional information on rating plate and on package label (max. of 20 characters)	0/106
<b>Packaging, safety notes, documentation and test certificates</b>		
B00	Without safety and commissioning note. Customer's declaration of renouncement required.	0/102
B01	With one safety and start-up guide per box pallet	0/102
B02	Acceptance test certificate 3.1 in accordance with EN 10204	0/102
B04	Printed operating instructions English/German enclosed	0/102
B83	<i>New!</i> Type test with heat run for horizontal motors, with acceptance	0/102
B99	Wire-lattice pallet	0/102
M01	Connected in star for dispatch	0/102
M02	Connected in delta for dispatch	0/102

### Overview

#### Cut-away diagram of a low-voltage motor



① Motor protection Page 0/110  
 Motor connection and connection box Page 0/113  
 Voltages, currents and frequencies Page 0/103

② Windings and insulation Page 0/108  
 Coolant temperature and site altitude Page 0/107

③ Heating and ventilation Page 0/111  
 Mechanical design and degrees of protection Page 0/118  
 Modular technology Page 0/127  
 Special technology Page 0/134

④ Bearings and lubrication Page 0/122

⑤ Shaft and rotor Page 0/121  
 Balance and vibration quantity Page 0/120

⑥ Colors and paint finish Page 0/100

⑦ Types of construction Page 0/116

⑧ Rating plates and extra rating plates Page 0/106

# IEC Squirrel-Cage Motors

## Introduction motors 1LE1/1PC1

### General technical data

#### Designs in accordance with standards and specifications

##### Applicable standards and specifications

The motors comply with the appropriate standards and regulations, especially those listed in the table below.

Title	IEC/EN	DIN EN
General specifications for rotating electrical machines	IEC 60034-1, IEC 60085	DIN EN 60034-1
Specification of the losses and efficiency of rotating electrical machines	IEC 60034-2	DIN EN 60034-2
Asynchronous AC motors for general use with standardized dimensions and outputs	IEC 60072 mounting dimensions only	DIN EN 50347
Restart characteristics for rotating electrical machines	IEC 60034-12	DIN EN 60034-12
Terminal designations and direction of rotation for electrical machines	IEC 60034-8	DIN EN 60034-8
Designation for type of construction, installation and connection box position	IEC 60034-7	DIN EN 60034-7
Entry to connection box	–	DIN 42925
Built-in thermal protection	IEC 60034-11	DIN EN 60034-11
Noise limit values for rotating electrical machines	IEC 60034-9	DIN EN 60034-9
IEC standard voltages	IEC 60038	DIN IEC 60038
Cooling methods for rotating electrical machines	IEC 60034-6	DIN EN 60034-6
Vibration severity of rotating electrical machines	IEC 60034-14	DIN EN 60034-14
Vibration limits	–	DIN ISO 10816
Degrees of protection of rotating electrical machines	IEC 60034-5	DIN EN 60034-5

##### National standards

The motors comply with the IEC or European standards listed above. The European standards replace the national standards in the following EU member states: Germany (VDE), France (NF C), Belgium (NBNC), Great Britain (BS), Italy (CEI), Netherlands (NEN), Sweden (SS), Switzerland (SEV) etc.

The motors also comply with various national standards. The following standards have been harmonized with IEC publication 60034-1 or replaced with DIN EN 60034-1 so that the motors can be operated at standard rated output.

Title	Country
CSAC22.2, No. 100	Canada
IS 325 IS 4722	India
NEK – IEC 60034-1	Norway

##### Tolerances for electrical data

According to DIN EN 60034, the following tolerances are permitted:

Motors which comply with DIN EN 60034-1 must have a voltage tolerance of  $\pm 5\%$  / frequency tolerance of  $\pm 2\%$  (Design A). If utilized, the admissible limit temperature of the temperature class may be exceeded by 10 K.

A tolerance of  $\pm 5\%$  also applies to the rated voltage range in accordance with DIN EN 60034-1. For rated voltage and rated voltage range, see Page 0/103.

Efficiency  $\eta$  at

$$P_{\text{rated}} \leq 150 \text{ kW: } -0.15 \cdot (1 - \eta)$$

$$P_{\text{rated}} > 150 \text{ kW: } -0.1 \cdot (1 - \eta)$$

With  $\eta$  being a decimal number.

$$\text{Power factor} - \frac{1 - \cos \varphi}{6}$$

- Minimum absolute value: 0.02
- Maximum absolute value: 0.07

Slip  $\pm 20\%$  (for motors  $< 1 \text{ kW}$   $\pm 30\%$  is admissible)

Locked-rotor current  $+20\%$

Locked-rotor torque  $-15\%$  to  $+25\%$

Breakdown torque  $-10\%$

Moment of inertia  $\pm 10\%$

Energy-saving motors with European efficiency classification in accordance with EU/CEMEP (European Committee of Manufacturers of Electrical Machines and Power Electronics)

Low-voltage motors in the output range of 1.1 to 90 kW, 2-pole and 4-pole are marked in accordance with the EU/CEMEP agreement with the efficiency class  $\text{EFF2}$  (Improved Efficiency) or  $\text{EFF3}$  (High Efficiency).

So that the requirements of efficiency classes  $\text{EFF1}$  and  $\text{EFF2}$  are fulfilled, the active parts of the motor have been optimized. The procedure for calculating the efficiency is based on the loss summation method according to IEC 60034-2.

##### Motors for the North American market

For motors which comply with North American regulations (NEMA, CSA, UL, etc.), it must always be checked whether the motors will be used in the US or Canada and whether they are subject to state laws.

##### Minimum efficiencies required by law

In 1997, an act was passed in the US to define minimum efficiencies for low-voltage three-phase motors (EPACT = Energy Policy Act). An act is in force in Canada that is largely identical, although it is based on different verification methods. The efficiency is verified for these motors for the USA using IEEE 112, Test Method B and for Canada using CSA-C390. Apart from a few exceptions, all low-voltage three-phase motors exported to the USA or Canada must comply with the legal requirements on efficiency.

The law requires minimum efficiencies for 2, 4 and 6-pole motors with a voltage of 230 and 460 V/60 Hz, in the output range of 1 to 200 HP (0.75 to 150 kW).

According to EPACT, the following are excluded from the efficiency requirements, for example.

- Motors whose frame size output classification does not correspond with the standard series according to NEMA MG1-12.
- Flange-mounting motors without feet
- Brake motors
- Converter-fed motors
- Motors with design letter C and higher

For more information on EPACT:

<http://www.eren.doe.gov/>

##### Special requirements for the USA: Energy Policy Act

The act lays down that the nominal efficiency at full load and a "CC" number (Compliance Certification) must be included on the rating plate. The "CC" number is issued by the US Department of Energy (DOE). The following information is stamped on the rating plate of EPACT motors which must be marked by law: Nominal efficiency (service factor SF 1.15), design letter, code letter, CONT, CC-Nr. CC 032A (Siemens) and NEMA MG1-12.

##### Special requirements for Canada: CSA – Energy Efficiency Verification

These motors fulfill the minimum efficiency requirements laid down by the CSA standard C390. These motors are available as 1LE1 and can be ordered with order code **D40** and are also marked with the CSA-E verification on the rating plate.



# IEC Squirrel-Cage Motors

## Introduction motors 1LE1/1PC1

### General technical data

0

#### NEMA – Order code D30

The motors with increased efficiency according to EPACT are designed to meet the NEMA MG1-12 electrical standard and are marked accordingly. The mechanical design of all motors is compliant only to IEC, not to NEMA dimensions.

All motors in the EPACT and **D30** version correspond to NEMA Design A (i. e. standard torque characteristic in accordance with NEMA and no starting current limitation).

For Design B, C and D, a special version is required (on request).

All other 1LE1/1PC1 motors must be ordered with order code **D30**.

Data on the rating plate: Rated voltage (voltage tolerance of 10 %), nominal efficiency, design letter, code letter, CONT and NEMA MG1-12.

#### UL approval – Order code D31

The motors based on the 1LE1/1PC1 basic series are listed for up to 600 V by Underwriters Laboratories Inc. ("Recognition Mark" = R/C).

This is not possible in combination with the option "temperature class 180 (H) at rated output and maximal coolant temperature of 60 °C", order code N11.

According to UL, motor voltages are only certified up to 600 V, i.e. voltage codes 22, 27 or 40. For this reason, the indication 690 VY for voltage code "34" (400 VΔ/690 VY/ 50 Hz or 460 VΔ/60 Hz), for example, is omitted on the rating plate.

The "UL Recognition Mark" is included on the rating plate of the motor.



In addition, the motor is designed to meet the NEMA MG1-12 electrical standard and includes the following data on the rating plate: Rated voltage (voltage tolerance of 10 %), nominal efficiency, design letter, code letter, CONT and NEMA MG1-12. The motors must only be ordered with order code **D31**.

Externally or internally mounted components such as

- Motor protection
- Heating element
- Separately driven fan
- Brake
- Encoder
- Power connection
- Plug connector

are UL-R/C, CSA or C-US listed or used by manufacturers in accordance with regulations. It may have to be decided whether the motor is suitable for the application.

The motors can be operated with a frequency converter with 50/60 Hz.

Deviating frequency settings must be tested at final acceptance.

The following versions are possible:

- 2-pole motors, only in combination with F77 or F78 low-noise versions
- 4, 6 and 8-pole motors, only in combination with F76 metal external fan

#### CSA approval – Order code D40

Motors based on the 1LE1/1PC1 basic series are approved for up to 690 V in accordance with the Canadian regulations of the "Canadian Standard Association" (CSA). Externally or internally mounted components which are used are listed by CSA or are used by manufacturers in accordance with regulations. It may have to be decided whether the motor is suitable for the application.

This is not possible in combination with the option "temperature class 180 (H) at rated output and maximal coolant temperature of 60 °C", order code N11, for 1LE1 and 1PC1 motor series.

The motors must be ordered with the order code **D40**, voltage code "90" and order code for voltage and frequency. The CSA mark and the rated voltage (voltage tolerance of 10 %) are included on the rating plate.



When energy-saving motors (1LE1 in design EFF1) are ordered, they also include the CSA-E mark on the rating plate.



Export of low-voltage motors to China

#### CCC – China Compulsory Certification – Order code D01

"Small power motors" which are exported to China must be certified up to a rated output of:

- 2-pole: ≤ 2.2 kW
- 4-pole: ≤ 1.1 kW
- 6-pole: ≤ 0.75 kW
- 8-pole: ≤ 0.55 kW

The **1LE1 motors which must be certified** have been certified by the CQC (China Quality Cert. Center). When ordered with the D01 order code, the "CCC" logo and "Factory Code" are included on the rating plate and packaging.



Factory Code:

**A005216** = Works Bad Neustadt

**A010607** = Works Mohelnice

Note:

Chinese customs checks the need for certification of imported products by means of commodity code.

The following do not need to be certified:

- Motors imported to China which have already been installed in a machine
- Repair parts

Export of low-voltage motors to Japan

#### PSE Mark Japan – Order Code D46

PSE marking is a mandatory certification in Japan in accordance with the electrical devices and safety of materials act. "Small power motors" with a rated output of up to 3 kW which are exported to Japan must bear the PSE marking.

The motors concerned are marked on the rating plate with the following "PSE" logo.



# IEC Squirrel-Cage Motors

## Introduction motors 1LE1/1PC1

### General technical data

0

#### Colors and paint finish

To protect the drives against corrosion and external influences, high-quality coatings based on 2-K epoxy resin are offered in various different colors.

Type	Suitability of paint finish for climate group in accordance with DIN IEC 60721, Part 2-1	
Special finish	Worldwide (global) for outdoor use in direct sunlight and/or weather conditions. Suitable for use in the tropics for <60 % relative humidity at 40 °C	Briefly: Up to 140 °C Contin.: Up to 120 °C Also: for aggressive atmospheres up to 1 % acid and alkali concentrations or permanent dampness in sheltered rooms

#### Special finish system "sea air resistant" – Order code **S03**

Field of application	Resistance
<ul style="list-style-type: none"> <li>Recommended for indoor installations or outdoor installations exposed to direct weather conditions</li> <li>Industrial climate with moderate SO<sub>2</sub> exposure, inshore maritime climate, but not offshore maritime climate, e.g. for crane drives and also in the paper industry</li> <li>Complies with the test requirements of DIN EN ISO 12944-2 Corrosion Category C4</li> </ul>	<ul style="list-style-type: none"> <li>Chemical exposure to 5 % acid and caustic solution concentration</li> <li>Suitable for use in the tropics up to 75 % relative humidity at 50 °C</li> <li>Thermal stability from –40 to 140 °C</li> </ul>

All motors are painted with RAL 7030 (stone gray) if the color is not specified.

Other colors in special finish must be ordered with order codes **Y51** or **Y54** and the required RAL number in plain text (for a selection of the available RAL numbers/colors, see the following page for tables for order codes **Y51** and **Y54**).

Direct sunlight may change the color. If consistent colors are required, we recommend paint based on polyurethane. Please inquire.

All paint finishes can be painted over with commercially available paints. Special paints and increased layer thickness available on request.

If required, the motors can be supplied coated only in primer, order code **S01**, or unpainted (unmachined cast-iron surfaces, but primed) using order code **S00**.

# IEC Squirrel-Cage Motors

## Introduction motors 1LE1/1PC1

### General technical data

0

Special finish in standard RAL colors – Order code **Y54** (RAL number is required in plain text)

RAL No.	Color name	RAL No.	Color name
1002	Sand yellow	6011	Reseda green
1013	Pearl white	6019	Pastel green
1015	Light ivory	6021	Pale green
1019	Gray beige	7000	Squirrel gray
2003	Pastel orange	7001	Silver gray
2004	Pure orange	7004	Signal gray
3000	Flame red	7011	Iron gray
3007	Black red	7016	Anthracite gray
5007	Brilliant blue	7022	Umber gray
5009	Azure blue	7031	Blue gray
5010	Gentian blue	7032	Pebble gray
5012	Light blue	7033	Cement gray
5015	Sky blue	7035	Light gray
5017	Traffic blue	9001	Cream
5018	Teal blue	9002	Gray white
5019	Capri blue	9005	Jet black

Special finish in special RAL colors – Order code **Y51** (RAL number is required in plain text)

RAL No.	Color name	RAL No.	Color name	RAL No.	Color name	RAL No.	Color name
1000	Green beige	3014	Antique pink	6003	Olive green	7036	Platinum gray
1001	Beige	3015	Light pink	6004	Blue green	7037	Dusty gray
1003	Signal yellow	3016	Coral red	6005	Moss green	7038	Agate gray
1004	Golden yellow	3017	Rose	6006	Gray olive	7039	Quartz gray
1005	Honey yellow	3018	Strawberry red	6007	Bottle green	7040	Window gray
1006	Maize yellow	3020	Traffic red	6008	Brown green	7042	Traffic gray A
1007	Daffodil yellow	3022	Salmon pink	6009	Fir green	7043	Traffic gray B
1011	Brown beige	3027	Raspberry red	6010	Grass green	7044	Silk gray
1012	Lemon yellow	3031	Orient red	6012	Black green	7045	Tele gray 1
1014	Dark ivory	3032	Pearl ruby red	6013	Reed green	7046	Tele gray 2
1016	Sulfur yellow	3033	Pearl pink	6014	Yellow olive	7047	Tele gray 4
1017	Saffron yellow	4001	Red lilac	6015	Black olive	7048	Pearl mouse gray
1018	Zinc yellow	4002	Red violet	6016	Turquoise green	8000	Green brown
1020	Olive yellow	4003	Heather violet	6017	May green	8001	Ocher brown
1021	Rape yellow	4004	Claret violet	6018	Yellow green	8002	Signal brown
1023	Traffic yellow	4005	Blue lilac	6020	Chrome green	8003	Clay brown
1024	Ochre yellow	4006	Traffic purple	6022	Olive drab	8004	Copper brown
1027	Curry	4007	Purple violet	6024	Traffic green	8007	Fawn brown
1028	Melon yellow	4008	Signal violet	6025	Fern green	8008	Olive brown
1032	Broom yellow	4009	Pastel violet	6026	Opal green	8011	Nut brown
1033	Dahlia yellow	4010	Tele magenta	6027	Light green	8012	Red brown
1034	Pastel yellow	4011	Pearl violet	6028	Pine green	8014	Sepia brown
1035	Pearl beige	4012	Pearl blackberry	6029	Mint green	8015	Chestnut
1036	Pearl gold	5000	Violet blue	6032	Signal green	8016	Mahogany
1037	Sun yellow	5001	Green blue	6033	Mint turquoise	8017	Chocolate
2000	Yellow orange	5002	Ultramarine	6034	Pastel turquoise	8019	Gray brown
2001	Red orange	5003	Sapphire blue	6035	Pearl green	8022	Black brown
2002	Vermilion	5004	Black blue	6036	Pearl opal green	8023	Orange brown
2008	Bright red orange	5005	Signal blue	7002	Olive gray	8024	Beige brown
2009	Traffic orange	5008	Gray blue	7003	Moss gray	8025	Pale brown
2010	Signal orange	5011	Steel blue	7005	Mouse gray	8028	Terra brown
2011	Deep orange	5013	Cobalt blue	7006	Beige gray	8029	Pearl copper
2012	Salmon orange	5014	Pigeon blue	7008	Khaki gray	9003	Signal white
2013	Pearl orange	5020	Ocean blue	7009	Green gray	9004	Signal black
3001	Signal red	5021	Water blue	7010	Tarpaulin gray	9006	White aluminum
3002	Carmine red	5022	Night blue	7012	Basalt gray	9007	Gray aluminum
3003	Ruby red	5023	Distant blue	7013	Brown gray	9010	Pure white
3004	Purple red	5024	Pastel blue	7015	Slate gray	9011	Graphite black
3005	Wine red	5025	Pearl gentian	7021	Black gray	9016	Traffic white
3009	Oxide red	5026	Pearl night blue	7023	Concrete gray	9017	Traffic black
3011	Brown red	6000	Patina green	7024	Graphite gray	9018	Papyrus white
3012	Beige red	6001	Emerald green	7026	Granite gray	9022	Pearl light gray
3013	Tomato red	6002	Leaf green	7034	Yellow gray	9023	Pearl dark gray

Coating structure and colors not specified in the catalog are available on request.

# IEC Squirrel-Cage Motors

## Introduction motors 1LE1/1PC1

### General technical data

0

#### Packaging, safety notes, documentation and test certificates

##### Connected in star for dispatch – Order code **M01**

The terminal board of the motor is connected in star for dispatch.

##### Connected in delta for dispatch – Order code **M02**

The terminal board of the motor is connected in delta for dispatch.

#### Packing weights

Packing weights		For land transport							
For motors Frame size	Type <b>1LE1 ... -</b> <b>1PC1 ... -</b>	Type of construction IM B3				Type of construction IM B5, IM V1			
		In box Tare	On wooden board ISPM covered by cardboard on top and sides Tare	On battens Tare	In crate Tare	In box Tare	On wooden board ISPM covered by cardboard on top and sides Tare	On battens Tare	In crate Tare
		kg	kg	kg	kg	kg	kg	kg	kg
100 L	<b>1A.4</b>	–	5.0	–	–	–	5.0	–	–
	<b>1A.5</b>	–	5.0	–	–	–	5.0	–	–
	<b>1A.6</b>	–	5.0	–	–	–	5.0	–	–
112 M	<b>1B.2</b>	–	5.0	–	–	–	5.0	–	–
	<b>1B.6</b>	–	5.0	–	–	–	5.0	–	–
132 S	<b>1C.0</b>	4.7	–	–	–	5.2	–	–	–
	<b>1C.1</b>	4.7	–	–	–	5.2	–	–	–
132 M	<b>1C.2</b>	4.7	–	–	–	5.2	–	–	–
	<b>1C.3</b>	4.7	–	–	–	5.2	–	–	–
	<b>1C.6</b>	8.7	–	–	–	9.2	–	–	–
160 M	<b>1D.2</b>	4.8	–	–	–	5.7	–	–	–
	<b>1D.3</b>	4.8	–	–	–	5.7	–	–	–
160 L	<b>1D.4</b>	4.8	–	–	–	5.7	–	–	–
	<b>1D.6</b>	8.8	–	–	–	9.7	–	–	–

Data apply for individual packaging. Packing in wire-lattice pallets can be used, order code **B99**.

#### Safety notes

If the motors are to be delivered without safety and commissioning notes, a customer's declaration of renouncement is required.

##### Without safety and commissioning note – Order code **B00**

The motors are supplied with only one set of safety and commissioning notes per wire-lattice pallet for most motor types and frame sizes.

##### Complete with one set of safety and commissioning notes per wire-lattice pallet – Order code **B01**

#### Documentation

The following documents are optionally available:

- Printed operating instructions English/German enclosed – Order code **B04**
- All manuals for low-voltage motors, geared motors and low-voltage converters are now available on DVD in 5 languages, see "SD Manual Collection for CA 01" in catalog part 11 "Appendix".

#### Test certificates

##### Acceptance test certificate 3.1 according to EN 10204 – Order code **B02**

An acceptance test certificate 3.1 according to EN 10204 can be supplied for most motors.

##### Type test with heat run for horizontal motors, with acceptance – Order code **B83**

During the type test, a temperature-rise test is performed; no-load, short-circuit and load characteristics are recorded; the iron losses and friction losses are determined and the efficiency is calculated from the summed losses. This option is only applicable to motors with a horizontal type of construction. The acceptance is carried out by an external representative (e.g. customer, classification society).



# IEC Squirrel-Cage Motors

## Introduction motors 1LE1/1PC1

### General technical data

0

#### Voltages, currents and frequencies

##### Standard voltages

EN 60034-1 differentiates between Category A (combination of voltage deviation  $\pm 5\%$  and frequency deviation  $\pm 2\%$ ) and Category B (combination of voltage deviation  $\pm 10\%$  and frequency deviation  $+3/-5\%$ ) for voltage and frequency fluctuations. The motors can supply their rated torque in both Category A and Category B. In Category A, the temperature rise is approx. 10 K higher than during rated duty.

Standard	Category	Category
60034 – 1	A	B
Voltage deviation	$\pm 5\%$	$\pm 10\%$
Frequency deviation	$\pm 2\%$	$+3\%/-5\%$
Rating plate data stamped with rated voltage a (e.g. 230 V)	a $\pm 5\%$ (e.g. 230 V $\pm 5\%$ )	a $\pm 10\%$ (e.g. 230 $\pm 10\%$ )
Rating plate data stamped with rated voltage ranges b to c (e.g. 220 to 240V)	b $-5\%$ to c $+5\%$ (e.g. 220 $-5\%$ to 240 $+5\%$ )	b $-10\%$ to c $+10\%$ (e.g. 220 $-10\%$ to 240 $+10\%$ )

According to the standard, longer duty is not recommended for Category B. See "Rating plates and extra rating plates" for details of the rating plate inscriptions and corresponding examples. The selection and ordering data state the rated current at 400 V. The DIN IEC 60038 standard specifies a tolerance of  $\pm 10\%$  for mains voltages of 230 V, 400 V and 690 V. The rating plates of motors with voltage code 22 or 34 specify a rated voltage range in addition to the rated voltage (see table below).

The rated currents at 380/420 V are specified in the table "Rated currents for rated voltage range 380 V to 420 V at 50 Hz" and on the rating plate.

Mains voltages	Rated voltage range	Voltage code
<b>1LE1 motors</b>		
230 V $\Delta$ /400 VY, 50 Hz	220 ... 240 V $\Delta$ /380 ... 420 VY, 50 Hz	22
400 V $\Delta$ /690 VY, 50 Hz	380 ... 420 V $\Delta$ /660 ... 725 VY, 50 Hz	34
500 VY, 50 Hz	–	27
500 V $\Delta$ , 50 Hz	–	40

##### Non-standard voltages and/or frequencies

The tolerance laid down by DIN EN 60034-1 applies to all non-standard voltages. Order codes have been allocated for a number of non-standard voltages at 50 or 60 Hz. They are ordered by specifying the code digit 9 for voltage in the 12th position of the Order No. as well as the code digit 0 in the 13th position of the Order No. and the appropriate order code.

**M1Y** Non-standard winding for voltages between 200 V and 690 V and rated outputs.

For voltages and rated outputs outside the range, please inquire.

Motor series	Frame size	Rated voltages that are available for <b>M1Y</b>	
		Lowest/highest voltage in V for	Star connection
<b>1LE1</b>	100 ... 160	200/690	250/690

Order codes for other rated voltages are listed under "Order No. supplements" in the "Selection and ordering data" as well as "Special versions" under "Voltages".

# IEC Squirrel-Cage Motors

## Introduction motors 1LE1/1PC1

### General technical data

Rated currents for rated voltage range 380 V to 420 V at 50 Hz

Motor type	Frame size	Currents for voltage and number of poles							
		380 V		420 V		380 V		420 V	
		2-pole		4-pole		6-pole		8-pole	
		/	/	/	/	/	/	/	/
		A	A	A	A	A	A	A	A
<b>General Line motors with shorter delivery time</b>									
<b>Self-ventilated energy-saving motors with improved efficiency – Aluminum series 1LE1</b>									
<b>Forced-air cooled motors without external fan and fan cover with improved efficiency – Aluminum series 1LE1</b>									
<b>1LE1002-1A.4</b>	100 L	6.3	5.7	5.0	4.9	3.75	4.15	2.8	3.3
<b>1LE1002-1A.5</b>	100 L	–	–	6.4	6.1	–	–	3.65	4.1
<b>1LE1002-1B.2</b>	112 M	8.3	7.5	8.4	8.1	5.4	5.5	4.0	4.4
<b>1LE1002-1C.0</b>	132 S	10.9	10.3	11.5	11.4	7.3	7.7	5.9	6.0
<b>1LE1002-1C.1</b>	132 S	14.5	13.9	–	–	–	–	–	–
<b>1LE1002-1C.2</b>	132 M	–	–	15.2	15.2	9.3	9.4	7.9	8.1
<b>1LE1002-1C.3</b>	132 M	–	–	–	–	13.7	12.9	–	–
<b>1LE1002-1D.2</b>	160 M	21.7	20.7	22.4	22.8	17.0	17.7	10.5	11.6
<b>1LE1002-1D.3</b>	160 M	29.6	28.9	–	–	–	–	13.8	14.6
<b>1LE1002-1D.4</b>	160 L	35.0	33.5	30.0	30.2	22.3	24.7	18.9	19.4
<b>Self-ventilated energy-saving motors with high efficiency – Aluminum series 1LE1</b>									
<b>Forced-air cooled motors without external fan and fan cover with high efficiency – Aluminum series 1LE1</b>									
<b>1LE1001-1A.4</b>	100 L	6.1	6.1	4.65	4.65	3.55	3.55	2.65	2.95
<b>1LE1001-1A.5</b>	100 L	–	–	6.2	6.1	–	–	3.85	4.35
<b>1LE1001-1B.2</b>	112 M	7.8	7.6	8.3	8.2	5.1	5.0	4.3	4.3
<b>1LE1001-1C.0</b>	132 S	10.1	10.5	11.4	11.4	7.0	7.1	6.6	6.6
<b>1LE1001-1C.1</b>	132 S	14.2	13.7	–	–	–	–	–	–
<b>1LE1001-1C.2</b>	132 M	–	–	14.8	14.4	8.6	8.9	7.9	8.2
<b>1LE1001-1C.3</b>	132 M	–	–	–	–	12	11.9	–	–
<b>1LE1001-1D.2</b>	160 M	20.0	21.0	21.5	20.5	16.1	15.8	9.8	9.6
<b>1LE1001-1D.3</b>	160 M	28.0	27.0	–	–	–	–	13.4	13.3
<b>1LE1001-1D.4</b>	160 L	34.0	33.0	28.5	27.5	22.5	21.5	17.5	16.8
<b>Self-ventilated motors with increased output with improved efficiency – Aluminum series 1LE1</b>									
<b>1LE1002-1A.6</b>	100 L	8.1	7.9	8.5	8.5	5.4	5	–	–
<b>1LE1002-1B.6</b>	112 M	11.2	10.2	12	10.8	7.5	8.0	–	–
<b>1LE1002-1C.6</b>	132 M	20.3	18.9	21.8	21.3	17.0	17.6	–	–
<b>1LE1002-1D.6</b>	160 L	40.2	37.9	36.1	35.5	33.5	34.0	–	–
<b>Self-ventilated motors with increased output and high efficiency – Aluminum series 1LE1</b>									
<b>1LE1001-1A.6</b>	100 L	7.8	7.6	8.3	8.4	5.0	4.95	–	–
<b>1LE1001-1B.6</b>	112 M	10.4	9.8	11.2	11.1	6.6	6.5	–	–
<b>1LE1001-1C.6</b>	132 M	20	19.1	21.5	21	16.5	16.5	–	–
<b>1LE1001-1D.6</b>	160 L	40.0	37.5	35.5	34.5	30.5	29.0	–	–

# IEC Squirrel-Cage Motors

## Introduction motors 1LE1/1PC1

### General technical data

#### Outputs

The outputs or rated outputs are listed in the selection tables for both 50 Hz and 60 Hz.

Assignment of the standard power kW-HP and vice versa in accordance with IEC

$$\text{kW} \cdot 1.341 = \text{HP}$$

$$\text{HP} \cdot 0.746 = \text{kW}$$

$P_{\text{rated}}$ kW	$P_{\text{rated}}$ HP	$P_{\text{rated}}$ kW	$P_{\text{rated}}$ HP	$P_{\text{rated}}$ kW	$P_{\text{rated}}$ HP	$P_{\text{rated}}$ kW	$P_{\text{rated}}$ HP	$P_{\text{rated}}$ kW	$P_{\text{rated}}$ HP	$P_{\text{rated}}$ kW	$P_{\text{rated}}$ HP
0.06	0.08	0.37	0.5	2.2	3	11	15	37	50	110	150
0.09	0.12	0.55	0.75	3	4	15	20	45	60	132	200
0.12	0.16	0.75	1	4	5	18.5	25	55	75	160	250
0.18	0.25	1.1	1.5	5.5	7.5	22	30	75	100	200	300
0.25	0.33	1.5	2	7.5	10	30	40	90	125		

#### Efficiency, power factor, rated torque, rated speed and direction of rotation

##### Efficiency and power factor

The efficiency  $\eta$  and power factor  $\cos \varphi$  for each rated output are listed in the selection tables in the individual sections of this catalog.

For EFF1 and EFF2 motors, the 3/4-load-efficiency is also indicated in the selection tables.

The part-load values stated in the two tables below are averages; precise values can be provided on request.

Part-load efficiency in % at				
1/4	1/2	3/4	4/4	5/4
of full load				
93	96	97	<b>97</b>	96.5
92	95	96	<b>96</b>	95.5
90	93.5	95	<b>95</b>	94.5
89	92.5	94	<b>94</b>	93.5
88	91.5	93	<b>93</b>	92.5
87	91	92	<b>92</b>	91.5
86	90	91	<b>91</b>	90
85	89	90	<b>90</b>	89
84	88	89	<b>89</b>	88
80	87	88	<b>88</b>	87
79	86	87	<b>87</b>	86
78	85	86	<b>86</b>	85
76	84	85	<b>85</b>	83.5
74	83	84	<b>84</b>	82.5
72	82	83	<b>83</b>	81.5
70	81	82	<b>82</b>	80.5
68	80	81	<b>81</b>	79.5
66	79	80	<b>80</b>	78.5
64	77	79.5	<b>79</b>	77.5
62	75.5	78.5	<b>78</b>	76.5
60	74	77.5	<b>77</b>	75
58	73	76	<b>76</b>	74
56	72	75	<b>75</b>	73
55	71	74	<b>74</b>	72
54	70	73	<b>73</b>	71
53	68	72	<b>72</b>	70
52	67	71	<b>71</b>	69
51	66	70	<b>70</b>	68
50	65	69	<b>69</b>	67
49	64	67.5	<b>68</b>	66
48	62	66.5	<b>67</b>	65
47	61	65	<b>66</b>	64
46	60	64	<b>65</b>	63
45	59	63	<b>64</b>	62
44	57	62	<b>63</b>	61
43	56	60.5	<b>62</b>	60.5
42	55	59.5	<b>61</b>	59.5
41	54	58.5	<b>60</b>	58.5

Part-load power factor at

1/4	1/2	3/4	4/4	5/4
of full load				
0.70	0.86	0.90	<b>0.92</b>	0.92
0.65	0.85	0.89	<b>0.91</b>	0.91
0.63	0.83	0.88	<b>0.90</b>	0.90
0.61	0.80	0.86	<b>0.89</b>	0.89
0.57	0.78	0.85	<b>0.88</b>	0.88
0.53	0.76	0.84	<b>0.87</b>	0.87
0.51	0.75	0.83	<b>0.86</b>	0.86
0.49	0.73	0.81	<b>0.85</b>	0.86
0.47	0.71	0.80	<b>0.84</b>	0.85
0.45	0.69	0.79	<b>0.83</b>	0.84
0.43	0.67	0.77	<b>0.82</b>	0.83
0.41	0.66	0.76	<b>0.81</b>	0.82
0.40	0.65	0.75	<b>0.80</b>	0.81
0.38	0.63	0.74	<b>0.79</b>	0.80
0.36	0.61	0.72	<b>0.78</b>	0.80
0.34	0.59	0.71	<b>0.77</b>	0.79
0.32	0.58	0.70	<b>0.76</b>	0.78
0.30	0.56	0.69	<b>0.75</b>	0.78
0.29	0.55	0.68	<b>0.74</b>	0.77
0.28	0.54	0.67	<b>0.73</b>	0.77
0.27	0.52	0.63	<b>0.72</b>	0.76
0.26	0.50	0.62	<b>0.71</b>	0.76

##### Rated speed and direction of rotation

The rated speeds are applicable for the rated data. The synchronous speed changes proportionally with the line frequency. The motors are suitable for clockwise and counter-clockwise rotation.

If U1, V1, W1 are connected to L1, L2, L3, clockwise rotation results as viewed onto the drive-end shaft extension. Counter-clockwise rotation is achieved by swapping two phases (see also "Heating and ventilation", Page 0/111).

##### Rated torque

The rated torque in Nm delivered at the motor shaft is

$$M = \frac{9.55 \cdot P \cdot 1000}{n}$$

$P$  Rated output in kW  
 $n$  Speed in rpm

##### Note:

If the voltage deviates from its rated value within the admissible limits, the locked-rotor torque, the pull-up torque and the breakdown torque vary with the approximate square of the value, but the locked-rotor current varies approximately linearly.

In the case of squirrel-cage motors, the locked-rotor torque and breakdown torque are listed in the selection tables as multiples of the rated torque.

The normal practice is to start squirrel-cage motors directly on line. The torque class indicates that with direct-on-line starting, even if there is an undervoltage of  $-5\%$ , it is possible to start up the motor against a load torque of

- 160 % for CL 16
- 130 % for CL 13
- 100 % for CL 10
- 70 % for CL 7
- 50 % for CL 5

of the rated torque.

# IEC Squirrel-Cage Motors

## Introduction motors 1LE1/1PC1

### General technical data

#### Rating plate and extra rating plates

DIN EN 60034-1 lays down that the approximate total weight for all motors is indicated on the rating plate.

An extra rating plate can be supplied loose for all motors, order code **M10**.

Non-rusting steel rating plate, for scratch, heat, cold and acid resistance can be obtained, order code **M11**.

Supplementary data (max. of 20 characters) can be indicated on the rating plate or extra rating plate and on the packaging label, order code **Y84**.

An extra rating plate for identification codes is also possible, order code **Y82**.

An extra rating plate or a rating plate with different rating plate data can also be ordered, order code **Y80**.

In the standard version, the rating plate is available in international format or in the German/English language. The language for the rating plate can be ordered by specifying it in plain text. An overview of the languages that can be ordered, at additional cost in some cases, is provided in the table below.

#### Overview of the languages on the rating plate

Motor type	Frame size	Rating plate							Double rating plate 50/60 Hz data for		
		International	German (de)	English (en)	German (de)/ English (en)	French (fr)/ Spanish (es)	Italian (it)	Portu- guese (pt)	Russian (ru)	500 VY and 575 VY	230 VΔ/ 400 VY and 460 V 500 VΔ and 575 VΔ
<b>1LE1/1PC1</b>	100 ... 160	<input checked="" type="checkbox"/>		<input type="checkbox"/>						<input checked="" type="checkbox"/>	<input checked="" type="checkbox"/>

- Standard version  
 Without additional charge

#### Example of a rating plate

**SIEMENS**  
D-91056 Erlangen

3-Mot. 1LE1 002-1DB43-4AA0- E0605/0496382 02 001

IEC/EN 60034 160L IMB3 IP55

73 kg Th.Cl. 155(F)

Bearing  
DE 6209-2ZC3  
NE 6209-2ZC3

V	Hz	A	kW	cos φ	eta	1/min	V	A
400 Δ	50	29,5	15	0,82	89,4%	1460	380-420	30,0-30,2
690 Y	50	17,1	15	0,82	89,4%	1460	660-725	17,4-17,5
460 Δ	60	29,5	17,3	0,82	89,4%	1760	440-480	30,2-29,8

Legend:

- 1 Machine type: Three-phase Low-voltage motor
- 2 Order No.
- 3 Factory number (Ident No., serial number)
- 4 Type of construction
- 5 Degree of protection
- 6 Rated voltage [V] and winding connections
- 7 Frequency [Hz]
- 8 Rated current [A]
- 9 Rated output [kW]
- 10 Power factor [cos φ]
- 11 Efficiency
- 12 Rated speed [rpm]
- 13 Voltage range [V]
- 14 Current range [A]
- 15 Machine weight [kg]
- 16 Standards and regulations
- 17 Temperature class
- 18 Frame size
- 19 Additional details (optional)
- 20 Operating temperature range (only if it deviates from normal)
- 21 Site altitude (only when higher than 1000 m)
- 22 Customer data (optional)
- 23 Date of manufacture YYMM

# IEC Squirrel-Cage Motors

## Introduction motors 1LE1/1PC1

### General technical data

0

#### Coolant temperature and site altitude

The rated output specified in the selection tables is applicable for continuous duty in accordance with DIN EN 60034-1 at the frequency of 50 Hz, a coolant temperature (CT) or ambient temperature of 40 °C and a site altitude (SA) up to 1000 m above sea level.

For higher coolant temperatures and/or site altitudes greater than 1000 m above sea level, the specified motor output must be reduced using the factor  $k_{HT}$ .

Depending on the frame size of the motor or the number of poles, special windings may be added to the motors for different operating conditions.

This results in an admissible output of the motor of:

$$P_{adm.} = P_{rated} \cdot k_{HT}$$

#### Reduction factor $k_{HT}$ for different site altitudes and/or coolant temperatures

Site altitude above sea level m	Site altitude above sea level Coolant temperature					
	<30 °C	30 °C ... 40 °C	45 °C	50 °C	55 °C	60 °C
1000	1.07	1.00	0.96	0.92	0.87	0.82
1500	1.04	0.97	0.93	0.89	0.84	0.79
2000	1.00	0.94	0.90	0.86	0.82	0.77
2500	0.96	0.90	0.86	0.83	0.78	0.74
3000	0.92	0.86	0.82	0.79	0.75	0.70
3500	0.88	0.82	0.79	0.75	0.71	0.67
4000	0.82	0.77	0.74	0.71	0.67	0.63

Coolant temperature and site altitude are rounded-off to 5 °C or 500 m.

For the following outputs, rms values are specified for coolant temperatures (CT) of 45 °C and 50 °C that must be specified when ordering.

Power kW	Admissible output at 50 Hz	
	for CT 45 °C kW	for CT 50 °C kW
<b>11</b>	10.5	10
<b>15</b>	14.5	13.8
<b>18.5</b>	17.8	17
<b>22</b>	21	20
<b>30</b>	29	27.5

For details of derating for use in class 155 (F), see "DURIGNIT IR 2000 insulation system".

Motors for coolant temperatures other than 40 °C or site altitudes higher than 1000 m above sea level for use in temperature class 130 (B) must always be ordered with the supplementary order code "**-Z**" and plain text. In the case of extreme derating, the operating data for the motors will also be less favorable due to partial utilization.

The following special versions are possible for 1LE1 and 1PC1 motors:

- Motors for coolant temperatures from -40 to +40 °C order code **D03**
- Motors for coolant temperatures from -30 to +40 °C order code **D04**

When ordering with order codes **D03** and **D04** in combination with mountings, the respective technical data have to be observed; request required.

For details of order codes for use in temperature class 155 (F), see "DURIGNIT IR 2000 insulation system" under "Windings and insulation", Page 0/108.

The following applies to all motors:

The motors can withstand 1.5 times the rated current at rated voltage and frequency for two minutes (DIN EN 60034).

If the admissible motor output is no longer adequate for the drive, it should be checked whether the motor with the next higher rated output fulfills the requirements.

Abbreviation	Description	Unit
$P_{adm.}$	Admissible motor output	kW
$P_{rated}$	Rated output	kW
$k_{HT}$	Factor for abnormal coolant temperature and/or site altitude	

The motors are designed for temperature class 155 (F) and used in temperature class 130 (B). Under non-standard operating conditions, if they are to be used in class 130 (B), the admissible output must be determined from the tables below.

#### Ambient temperature:

All motors can be used in the standard version at ambient temperatures between -20 to +40 °C.

Motors can be used in temperature class 155 (F)

- at 40 °C with service factor 1.1, i.e. the motor can be continuously overloaded with 10 % of the rated output in the case of EFF2 motors
- at 40 °C with service factor 1.15, i.e. the motor can be continuously overloaded with 15 % of the rated output in the case of EFF1 motors
- above 40 °C at rated output.

When motors are used in temperature class 130 (B) for higher ambient temperatures and/or site altitudes, derating occurs in accordance with the table "Reduction factor  $k_{HT}$  for different site altitudes and/or coolant temperatures".

For motors ex stock, the service factor is indicated on the rating plate.

For other temperatures, special measures are necessary. When brakes are to be mounted on at temperatures below freezing, please inquire.

# IEC Squirrel-Cage Motors

## Introduction motors 1LE1/1PC1

### General technical data

0

#### Windings and insulation

##### DURIGNIT IR 2000 insulation system

The DURIGNIT IR 2000 insulation system comprises high-grade enameled wires and insulating sheet materials combined with solvent-free impregnating resin.

The system ensures a high level of mechanical and electrical strength as well as good serviceability and a long motor life.

The insulation system protects the winding against aggressive gases, vapors, dust, oil and increased air humidity. It can withstand the usual vibration stressing.

The insulation is suitable up to an absolute air humidity of 30 g water per m<sup>3</sup> of air. Moisture condensation should be prevented from forming on the winding. Please inquire if higher values are required.

Please inquire about extreme applications.

##### Restarting against residual field and opposite phase

All motors can be reclosed against 100 % residual field after a mains voltage failure.

##### Winding and insulation design with regard to temperature class and air humidity

All motors are designed for temperature class 155 (F).

At rated output with mains-fed operation, the motors can be used in temperature class 130 (B).

#### **Temperature class 155 (F), used according to 155 (F), with service factor (SF)**

For all 1LE1/1PC1 motors for mains-fed operation for the rated output given in the selection table and rated voltage, a service factor of 1.1 can be specified for EFF2 motors (SF = 1.15 for EFF1 motors) also for motors with increased output.

Order code **N01**

#### **Temperature class 155 (F), used according to 155 (F), for increased output**

When used according to temperature class 155 (F), the rated output as specified in the selection and ordering data can be increased by 10 % for EFF2 motors (15 % for EFF1 motors) also for motors with increased output.

Order code **N02**

#### **Temperature class 155 (F), used according to 155 (F), with increased coolant temperature**

For mains-fed motors at outputs in accordance with the catalog, the coolant temperature can be raised to 55 °C.

Order code **N03**

The service factor (SF) is not indicated on the rating plate for order codes N02 and N03.

For converter-fed operation at the output specified in the catalog, the motors are used in accordance with temperature class 155 (F). Order codes N01, N02 and N03 are not possible. This applies to motors up to 460 V.

#### **Temperature class 155 (F), used according to 155 (F), other requirements**

The motors can be ordered according to temperature class 155 (F) for use according to temperature class 155 (F) with other customized requirements if they are specified in plain text in the order.

Order code **Y52**

#### **Temperature class 180 (H) at rated output and maximum coolant temperature CT 60 °C**

For motor series 1LE1 and 1PC1, use according to temperature class 180 (H) is permitted at rated output and at a maximum coolant temperature of 60 °C. This does not apply to motor series 1LE1 and 1PC1 with UL approval (order code D31) and CSA approval (order code D40). The specified grease life applies to a coolant temperature of 40 °C. For a 10 K increase in coolant temperature, the grease life or lubrication interval is halved.

Order code **N11**

#### **Temperature class 155 (F), used according to 130 (B), coolant temperature 45 °C, approx. 4 % derating**

For the 1LE1 motor series, a version for temperature class 155 (F) can be used according to temperature class 130 (B) at a maximum coolant temperature of 45 °C with a 4 % reduction in rated output.

Order code **N05**

#### **Temperature class 155 (F), used according to 130 (B), coolant temperature 50 °C, approx. 8 % derating**

For the 1LE1 motor series, a version for temperature class 155 (F) can be used according to temperature class 130 (B) at a maximum coolant temperature of 50 °C with a 8 % reduction in rated output.

Order code **N06**

#### **Temperature class 155 (F), used according to 130 (B), coolant temperature 55 °C, approx. 13 % derating**

For the 1LE1 motor series, a version for temperature class 155 (F) can be used according to temperature class 130 (B) at a maximum coolant temperature of 55 °C with a 13 % reduction in rated output.

Order code **N07**

#### **Temperature class 155 (F), used according to 130 (B), coolant temperature 60 °C, approx. 18 % derating**

For the 1LE1 motor series, a version for temperature class 155 (F) can be used according to temperature class 130 (B) at a maximum coolant temperature of 60 °C with a 18 % reduction in rated output.

Order code **N08**

#### **Increased air temperature/humidity with 30 to 60 g water per m<sup>3</sup> of air**

For motors of series 1LE1 and 1PC1, a version can be ordered for increased air humidity of between 30 and 60 g water per m<sup>3</sup> of air depending on the temperature as listed in the table below. This option includes condensation drainage holes (order code H03).

Order code **N20**

Please contact your local Siemens office if order code N20 is to be combined with additional mountings (eg. rotary pulse encoders, brakes).

#### **Increased air temperature/humidity with 60 to 100 g water per m<sup>3</sup> of air**

For motors of series 1LE1 and 1PC1, a version can be ordered for increased air humidity of between 60 and 100 g water per m<sup>3</sup> of air depending on the temperature as listed in the table below. This option includes condensation drainage holes (order code H03).

Order code **N21**

Please contact your local Siemens office if order code N21 is to be combined with additional mountings (eg. rotary pulse encoders, brakes).

# IEC Squirrel-Cage Motors

## Introduction motors 1LE1/1PC1

### General technical data

0

#### Absolute/relative conversion of air humidity

Relative humidity	Temperature							
	20 °C	30 °C	40 °C	50 °C	60 °C	70 °C	80 °C	90 °C
10 %	2	3	5	8	13	20	29	42
15 %	3	5	8	12	19	30	44	63
20 %	3	6	10	17	26	39	58	84
25 %	4	8	13	21	32	49	73	105
30 %	5	9	15	25	39	59	87	126
35 %	6	11	18	29	45	69	102	146
40 %	7	12	20	33	52	79	116	167
45 %	8	14	23	37	58	89	131	188
50 %	9	15	26	41	65	98	145	209
55 %	10	17	28	46	71	108	160	230
60 %	10	19	31	50	78	118	174	251
65 %	11	20	33	54	84	128	189	272
70 %	12	21	36	58	91	138	203	293
75 %	13	23	38	62	97	148	218	314
80 %	14	24	41	66	104	157	233	335
85 %	15	26	43	70	110	167	247	356
90 %	16	27	46	74	117	177	262	377
95 %	16	29	49	79	123	187	276	398
100 %	17	30	51	83	130	197	291	419

The values in the table with a blue background are covered by the standard version (up to 30 g water per m<sup>3</sup> of air).

The values in the table with a light gray background are covered by order code **N20** (30 to 60 g of water per m<sup>3</sup> of air).

The values in the table with a dark gray background are covered by order code **N21** (60 to 100 g of water per m<sup>3</sup> of air).

Please contact your local Siemens office regarding requirements exceeding 100 g water per m<sup>3</sup> of air

#### Restarting against residual field and opposite phase

All motors can be reclosed against 100 % residual field after a mains voltage failure.

# IEC Squirrel-Cage Motors

## Introduction motors 1LE1/1PC1

### General technical data

0

#### Motor protection

The order variants for motor protection are coded with letters in the 15th position of the Order No. and, if necessary, using order codes.

In the standard version, the motor is designed without motor protection.

15th position of Order No. letter **A**

A distinction is made between current-dependent and motor-temperature-dependent protection devices.

#### Current-dependent protection devices

**Fuses** are only used to protect mains cables in the event of a short-circuit. They are not suitable for overload protection of the motor.

The motors are usually protected by delayed overload protection devices (circuit breakers for motor protection or overload relays).

This protection is current-dependent and is particularly effective in the case of a locked rotor.

For standard duty with short start-up times and starting currents that are not excessive and for low numbers of switching operations, motor protection switches provide adequate protection. Motor protection switches are not suitable for heavy starting duty or large numbers of switching operations. Differences in the thermal time constants for the protection equipment and the motor results in unnecessary early tripping when the protection switch is set to rated current.

#### Motor-temperature-dependent protection devices

**Temperature detectors** installed in the motor winding are suitable protection devices in the case of slowly rising motor temperature.

When a limit temperature is reached, these **bimetal switches** (NC contacts) can deactivate an auxiliary circuit. The circuit can only be reclosed following a considerable fall in temperature. When the motor current rises quickly (e.g. with a locked rotor), these switches are not suitable due to their large thermal time constants.

Temperature detectors for tripping

15th position of Order No. letter **Z** and order code **Q3A**

The most comprehensive protection against thermal overloading of the motor is provided by **PTC thermistors (thermistor motor protection)** installed in the motor winding. The temperature of the winding can be accurately monitored thanks to its low heating capacity and the excellent heat contact with the winding. When a limit temperature is reached (rated tripping temperature), the PTC thermistors undergo a step change in resistance. This is evaluated by a tripping unit and can be used to open auxiliary circuits. The PTC thermistors themselves cannot be subjected to high currents and voltages. This would result in destruction of the semiconductor. The switching hysteresis of the PTC thermistor and tripping unit is low, which supports fast re-starting of the drive. Motors with this type of protection are recommended for heavy duty starting, switching duty, extreme changes in load, high ambient temperatures or fluctuating supply systems.

Motor protection with PTC thermistors with 3 embedded temperature sensors for tripping. In the connection box, 2 auxiliary terminals are required.

15th position of Order No. letter **B**

The temperature detectors have the following current carrying capacity and switching capacity:

230 V AC  $\cos\phi$ : 2.5 A

24 V DC: 1.6 A

Two sets of three temperature sensors are used if a warning is required before the motor is shut down (tripped). The warning is normally set to 10 K below the tripping temperature.

Motor protection with PTC thermistors with 6 embedded temperature sensors for alarm and tripping. In the connection box, 4 auxiliary terminals are required.

15th position of Order No. letter **C**

In order to achieve full thermal protection, it is necessary to combine a thermally delayed overcurrent release and a PTC thermistor. For full motor protection implemented only with PTC thermistors, please inquire.

#### Motor temperature detection with converter-fed operation

##### KTY 84-130 temperature sensor

This sensor is a semiconductor that changes its resistance depending on temperature in accordance with a defined curve.

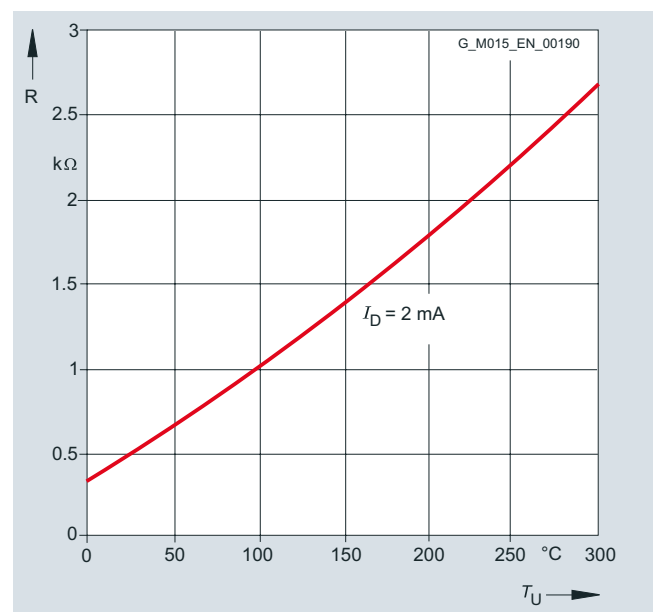

KTY 84-130 temperature sensor characteristic

Some converters from Siemens determine the motor temperature using the resistance of the temperature sensor. They can be set to a required temperature for alarm and tripping.

Motor temperature detection with embedded temperature sensor KTY 84-130. Two auxiliary terminals are required in the connection box.

15th position of Order No. letter **F**

The temperature sensor is embedded in the winding head of the motor in the same manner as a PTC thermistor. Evaluation is performed, for example, in the converter.

For mains-fed operation, the temperature monitoring device 3RS10 that is part of the protection equipment can be ordered separately. For further details, see Catalog LV 1, Order No.: E86060-K1002-A101-A7-7600.

With NTC thermistors (mainly in the case of special machines), the tripping temperature can also be adjusted later on the tripping unit. NTC thermistors for tripping

15th position of Order No. letter **Z** and order code **Q2A**



# IEC Squirrel-Cage Motors

## Introduction motors 1LE1/1PC1

### General technical data

0

#### Heating and ventilation

##### Anti-condensation heaters

Supply voltage 230 V (1~)  
Order code **Q02**

Supply voltage 115 V (1~)  
Order code **Q03**

Motors whose windings are at risk of condensation due to the climatic conditions, e.g. inactive motors in humid atmospheres or motors that are subjected to widely fluctuating temperatures, can be equipped with anti-condensation heaters.

An additional M16 x 1.5 cable entry is provided for the connecting cable in the connection box.

Anti-condensation heaters must not be switched on during operation.

Motor series	Frame size	Heater output of anti-condensation heaters in Watt (W)	
		Supply voltage at 230 V	Supply voltage at 115 V
		Order code <b>Q02</b>	Order code <b>Q03</b>
<b>1LE1/1PC1</b>	100 ... 112	50	50
<b>1LE1/1PC1</b>	132 ... 160	100	100

Instead of an anti-condensation heater, another possibility (at no extra cost) is connection of a voltage that is approximately 4 to 10 % of the rated motor voltage to stator terminals U1 and V1; 20 to 30 % of the rated motor current are sufficient to heat the motor.

##### Fans/Separately driven fans

1LE1 motors of frame sizes 100 ... 160 have radial-flow fans in the standard version (with the exception of 1LE1 with option F90 – version “Forced-air cooled motors without external fan and fan cover”) that cool regardless of the direction of rotation of the motor (cooling method IC 411 acc. to DIN EN 60034-6). The air flow is forced from the non-drive-end (NDE) to the drive end (DE). For details of separately driven fans for frame sizes 100 ... 160, see Page 0/129.

Supply voltage of separately driven fan for 1LE1 motors:  
The supply voltage tolerance of the separately driven fan is  $\pm 5\%$ ; for voltage ranges, Page 0/129.

When the motor is mounted and the air intake is restricted, it must be ensured that a minimum clearance is maintained between the fan cover and the wall. This clearance is calculated from the difference between the protective cover and the fan cover (differential dimension LM – L) or is specified in the detailed dimension drawing (see also Dimensional drawings from Page 1/68).

For design of the fan/separately driven fan and the fan cover, see the table below.

Motor series	Frame size	Fan material	Fan cover material
<b>1LE1</b>	100 ... 160	plastic	plastic <sup>1)</sup>

##### Metal external fan impeller

The standard fan impeller made of plastic can be replaced with a fan impeller made of metal. This version can be supplied 1LE1 (with the exception of 1LE1 with option F90 – version “Forced-air cooled motors without external fan and fan cover”). With the 1LE1 motor series, the metal fan can also be used for converter-fed operation.

A metal external fan is already included for the low-noise version.

Up to frame size 160, the metal external fan impeller is manufactured from sheet aluminum or steel.

Order codes **F76**

##### Fan cover for textile industry

For motors 1LE1 (with the exception of 1LE1 with option F90 – version “Forced-air cooled motors without external fan and fan cover”), the fan cover can be used in the standard version for the textile industry.

For motor series 1LE1 (with the exception of 1LE1 with option F90 – version “Forced-air cooled motors without external fan and fan cover”), a version of the fan cover can be supplied specially for the textile industry. This has a protective cover and is made of non-corrosive sheet steel.

When a fan cover is mounted for the textile industry, the length of the motor increases by 64 mm for frame sizes 100/112 and by 71 mm for frame sizes 132/160.

Order code **F75**

##### Sheet metal fan cover

For 1LE1 motor series (with the exception of 1LE1 with option F90 – version “Forced-air cooled motors without external fan and fan cover”), the fan cover can be supplied in sheet metal instead of plastic.

Order code **F74**

<sup>1)</sup> The sheet metal fan cover is used for type of construction codes **A, D, F, H, J, K, L, N, T, U, V** in combination with option **H03** (condensation drainage holes). Mounted separately driven fans and brakes are only available for versions with sheet metal fan covers.

# IEC Squirrel-Cage Motors

## Introduction motors 1LE1/1PC1

### General technical data

0

#### Necessary minimum cooling air flow for forced-air-cooled motors in standard duty

The required cooling air flow indicated in the selection table applies to continuous duty according to DIN EN 60034-1 at a coolant temperature (CT) and ambient temperature, respectively, of 40 °C and a site altitude (SA) of up to 1000 m above sea level.

In the motor version without external fan and fan cover, order code **F90**, the motor is located in the air flow of the fan to be

driven which must drive the minimum cooling air flow over the motor housing. The minimum air flow must pass closely over the housing (comparable to self-ventilation of the motor). Otherwise, higher air flows are required to comply with admissible motor heating levels. For a higher cooling air flow, the operating temperature of the motor can be reduced.

Frame size	Required cooling air flow for number of poles									
	2		4				6		8	
	EFF1/EFF2		EFF1		EFF2		EFF1/EFF2		EFF1/EFF2	
	50 Hz	60 Hz	50 Hz	60 Hz	50 Hz	60 Hz	50 Hz	60 Hz	50 Hz	60 Hz
	m <sup>3</sup> /min.	m <sup>3</sup> /min.	m <sup>3</sup> /min.	m <sup>3</sup> /min.	m <sup>3</sup> /min.	m <sup>3</sup> /min.	m <sup>3</sup> /min.	m <sup>3</sup> /min.	m <sup>3</sup> /min.	m <sup>3</sup> /min.
100	3.8	4.4	2.1	2.6	2.3	2.8	1.5	1.8	1.2	1.3
112	5.0/5.4 <sup>1)</sup>	5.7/6.1 <sup>1)</sup>	2.9	3.5	2.9	3.5	1.9	2.3	1.4	1.6
132	6.3	7.3	4.6	5.7	4.6	5.7	3.1	3.8	2.4	2.9
160	10.9	13.3	6.7	8.1	7.6	9.1	5	6.1	3.8	4.5

<sup>1)</sup> Value: EFF1/EFF2

# IEC Squirrel-Cage Motors

## Introduction motors 1LE1/1PC1

### General technical data

0

#### Motor connection and connection box

##### Connection, circuit and connection box

##### Location of the connection box

The order variants for motor connection are coded with digits in the 16th position of the Order No.

The connection box of the motor can be mounted in four different locations or positions. The position of the connection box must always be viewed from the drive end (DE).

The standard position of the connection box for *General Line motors* is on top  
16th position of Order No. digit **0**.

The standard position of the connection box for all other motors is on top  
16th position of Order No. digit **4**.

For all motors with feet (apart from motors with increased output), cast feet are standard. If rotation of the connection box in the future has to be provided for, it is recommended that the option "Screwed-on feet" (instead of cast feet), order code **H01**, is ordered.

For motors with feet and increased output, screwed-on feet are standard. The connection box can be rotated later.

Connection box on RHS  
16th position of Order No. digit **5**.

Connection box on LHS  
16th position of Order No. digit **6**.

Connection box bottom  
16th position of Order No. digit **7**.

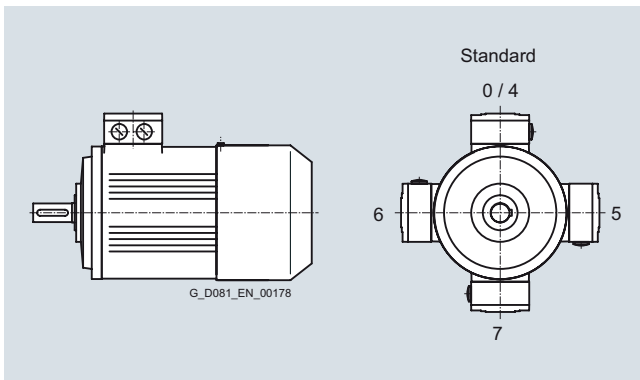

Location of the connection box with the corresponding digits in the 16th position of the order number

The number of winding ends depends on the winding design. Three-phase motors are connected to the three phase conductors L1, L2 and L3 of a three-phase system. The rated voltage of the motor in the running connection must match the phase conductor voltages of the network.

When the three phases are operating in a time sequence and are connected to the terminals of the motor in alphabetical order U1, V1 and W1, clockwise rotation is established as viewed from the motor shaft. The direction of rotation of the motor can be reversed if two connecting leads are interchanged.

Labeled terminals are provided to connect the protective conductor.

A PE terminal is provided in the connection box for grounding. A grounding terminal is provided on the outside of the motor frame – special version for 1LE1/1PC1 motors.

Order code **H04**.

If a brake control system or thermal protection is installed, the connections will also be in the connection box. The motors are suitable for direct connection to the line supply.

#### Design of the connection box

The number of terminals and the size of the connection box are designed for standard requirements.

For special requirements or upon the customer's request, a larger connection box, can be delivered.

Order code **R50**

If the necessary installation angle of the motor would cause machine components to collide with the connection box, the connection box can be moved from the drive end (DE) to the non-drive end (NDE). Only use according to temperature class 155 (F) possible.

Order code **H08**

Not possible for explosion-proof motors.

#### Motor connection

##### Line feeder cables

The line feeder cables must be dimensioned acc. to DIN VDE 0298. The number of required feeder cables, if necessary in parallel, is defined by:

- The max. cable cross-section which can be connected
- The cable type
- Routing
- Ambient temperature and the corresponding admissible current in accordance with DIN VDE 0298

For motors with auxiliary terminals (e.g. 15th position of Order No. is letter **B**) an M16 x 1.5 cable gland with plug is additionally provided.

For further details, see the data sheet function in the SD generator.

The connection box is located on the housing and bolted in place. The connection box can be turned 4 x 90° on the terminal base of the machine's housing in the case of a terminal board with 6 terminal studs (standard design).

There are 2 entry holes at the standard position complete with sealing plugs and locknuts (see figure).



Connection box in standard position

# IEC Squirrel-Cage Motors

## Introduction motors 1LE1/1PC1

### General technical data

0

#### Cable entry on connection box

Unless stated otherwise, the cable entry is located in the standard position as shown in the illustration.

The connection box can also be rotated such that the cable entry is located

- Towards the drive end (DE)  
(rotation of connection box by 90°, entry from DE)  
Order code **R10**
- Towards the non-drive end (NDE)  
(rotation of connection box by 90°, entry from NDE)  
Order code **R11**
- Opposite  
(rotation of connection box by 180°, entry from opposite end)  
Order code **R12**

The dimensions of the connection box are listed in part "Dimensions", see Pages 1/65 to 1/75 in accordance with the frame size and the "Dimension drawings".

If the position of the connection box (connection box RHS, LHS or above) is changed, the position of the cable entry must be checked and, if necessary, it can be ordered with the corresponding order codes (**R10**, **R11** and **R12**).

#### Ordering example:

Connection box on RHS (16th position of Order No. digit 5):  
Without additional order code, cable entry from below.

With additional order code **R10**:  
Cable entry from drive end (DE)



Connection box in standard position, detailed view

For cable entry to a standard connection box, a metal cable entry can be ordered for motor connection.  
One cable gland, metal  
Order code **R15**

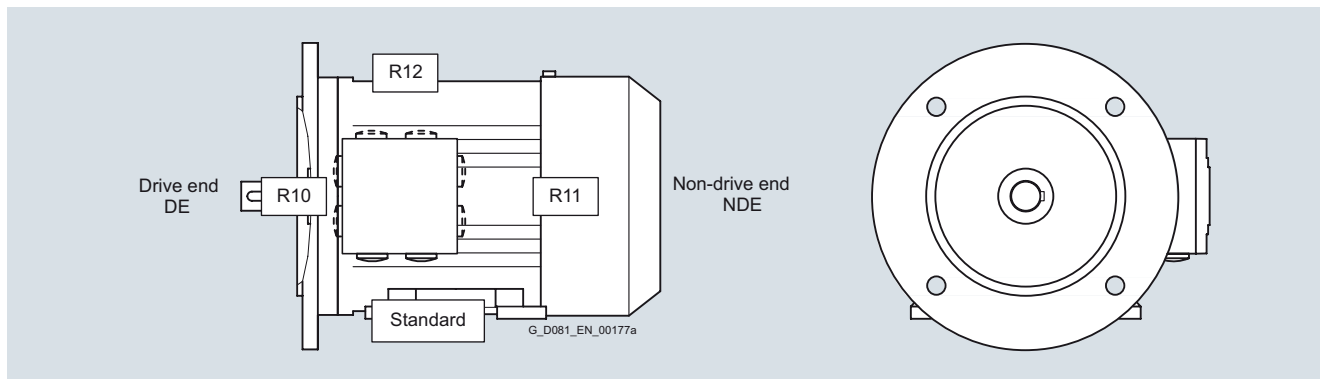

Locations of the cable entries with corresponding order codes

For special requirements for which standard holes for the cable entries are inadequate for the British market in UK, reduction pieces for M cable glands in accordance with British Standard that are mounted on both cable entries can be supplied.

Order code **R30**

Frame size	Cable entry acc. to	
	IEC	British Standard
100	2 x M32	2 x M20
112/132	2 x M32	2 x M25
160	2 x M40	2 x M32

#### Protruding cable ends

For confined spaces, protruding cable ends can be ordered, without a connection box with cover plate.

The following lengths of protruding cables can already be ordered using order codes on request:

- 3 cables protruding, 0.5 m long <sup>1)</sup>  
Order code **R20**
- 3 cables protruding, 1.5 m long <sup>1)</sup>  
Order code **R21**
- 6 cables protruding, 0.5 m long  
Order code **R22**
- 6 cables protruding, 1.5 m long  
Order code **R23**
- 6 cables protruding, 3.0 m long  
Order code **R24**

The cross-section of the named cables refers to a coolant temperature up to CT 40 °C.

<sup>1)</sup> With only 3 protruding cables additional plain text specifying star or delta connection is required.

# IEC Squirrel-Cage Motors

## Introduction motors 1LE1/1PC1

### General technical data

0

#### Connection, circuit and connection box

Standard connection box TB1 F00, TB1 H00, TB1 J00



Larger connection box type TB1F10, TB1H10, TB1J10



#### Standard connection boxes/larger connection box for 1LE1/1PC1 motors – basic data

Motors	Frame size	Number of cable entries	Connection box material	Feeder connection
<b>1LE1</b>	100 ... 160	2 entries complete with sealing plugs and locknuts Connection box is mounted and bolted in place.	Aluminum alloy	Without cable lug

#### Possible positions of the standard connection boxes/Larger connection box for 1LE1/1PC1 motors

Motors	Frame size	Connection box position			Rotation of connection box		Retrofitting possible
		Above	Side, right or left	Retrofitting possible	90°	180°	
<b>1LE1</b>	100 ... 160	○	○	– <sup>1)</sup>	○	○	Yes

○ Available version

#### Standard connection boxes/larger connection box for 1LE1/1PC1 motors in standard version

Frame size	Connection box	Number of terminals	Contact screw thread	Max. connectable cross-section	Outer cable diameter (sealing range)	Cable entry <sup>2)</sup>	Two-part plate Adm. outer cable diameter
	standard / larger			mm <sup>2</sup>	mm		mm
<b>1LE1</b>							
100	TB1 F00/TB1F10	6	M4	4	11 ... 21	2 x M32 x 1.5	–
112							
132	TB1 H00/TB1H10	6	M4	6	11 ... 21	2 x M32 x 1.5	–
160	TB1 J00/TB1J10	6	M5	16	19 ... 28	2 x M40 x 1.5	–

– Not available

#### Terminal connection

The terminal board accommodates the terminals that are connected to the leads to the motor windings. The terminals are designed so that for frame sizes 100 ... 160 the external (line) connections can be made without the need for cable lugs.

<sup>1)</sup> Retrofittable screwed-on feet (16th position of Order No. digit **5, 6, 7** and **4** with order code **H01**).

<sup>2)</sup> Designed for cable glands with O-ring.

# IEC Squirrel-Cage Motors











## Introduction motors 1LE1/1PC1

### General technical data

0

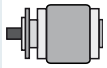
#### Types of construction

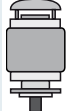
##### Standard types of construction and special types of construction

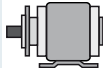
Type of construction acc. to DIN EN 60034-7		Frame size	Letter 14th position of the Order No.	Order No. supplement <b>-Z</b> with order code
<b>Without flange</b>				
IM B3		100 L to 160 L	<b>A</b>	–
IM B6/IM 1051		100 L to 160 L	<b>T</b>	–
IM B7/IM 1061		100 L to 160 L	<b>U</b>	–
IM B8/IM 1071		100 L to 160 L	<b>V</b>	–
IM V5/IM 1011 without protective cover		100 L to 160 L	<b>C</b>	–
IM V6/IM 1031		100 L to 160 L	<b>D</b>	–
IM V5/IM 1011 with protective cover		100 L to 160 L	<b>C</b>	<b>+ H00</b> <sup>1)</sup>
<b>With flange</b>				
IM B5/IM 3001		100 L to 160 L	<b>F</b>	–
IM V1/IM 3011 without protective cover		100 L to 160 L	<b>G</b>	–
IM V1/IM 3011 with protective cover		100 L to 160 L	<b>G</b>	<b>+ H00</b> <sup>1)</sup>
IM V3/IM 3031		100 L to 160 L	<b>H</b>	–
IM B35/IM 2001		100 L to 160 L	<b>J</b>	–











In the DIN EN 50347 standard, flanges FF with through holes and flanges FT with tapped holes are specified.

<sup>1)</sup> A second shaft extension **L05** is not possible.

# IEC Squirrel-Cage Motors

## Introduction motors 1LE1/1PC1

### General technical data

Type of construction acc. to DIN EN 60034-7		Frame size	Letter 14th position of the Order No.	Order No. supplement <b>-Z</b> with order code
<b>With standard flange</b>				
IM B14/IM 3601		100 L to 160 L	<b>K</b>	–
IM V19/IM 3631		100 L to 160 L	<b>L</b>	–
IM V18/IM 3611 without protective cover		100 L to 160 L	<b>M</b>	–
IM V 18/IM 3611 with protective cover		100 L to 160 L	<b>M</b>	<b>+ H00</b> <sup>1)</sup>
IM B34/IM 2101		100 L to 160 L	<b>N</b>	–
<b>With special flange (next larger standard flange)</b>				
IM B14/IM 3601		100 L to 160 L	<b>K</b>	<b>+ P01</b>
IM V19/IM 3631		100 L to 160 L	<b>L</b>	<b>+ P01</b>
IM V18/IM 3611 without protective cover		100 L to 160 L	<b>M</b>	<b>+ P01</b>
IM V 18/IM 3611 with protective cover		100 L to 160 L	<b>M</b>	<b>+ P01</b> <b>+ H00</b> <sup>1)</sup>
IM B34/IM 2101		100 L to 160 L	<b>N</b>	<b>+ P01</b>

In DIN EN 50347, standard flanges are assigned to the frame sizes as FT with tapped holes. The special flange was assigned as a large flange in the previous DIN 42677.

The dimensions of the following types of construction are identical:

IM B3, IM B6, IM B7, IM B8, IM V5 and IM V6  
IM B5, IM V1 and IM V3  
IM B14, IM V18 and IM V19

Motors in the standard output range can be ordered in basic types of construction IM B3, IM B5 and IM B14 and can be operated in the following mounting positions – IM B6, IM B7, IM B8, IM V5, IM V6, IM V1, IM V3 (up to frame size 160 L) or IM V18 and IM V19. Eyebolts are available for transport and installation in a horizontal position. In conjunction with the eyebolts, for the purpose of stabilizing the position when the motor is arranged vertically, additional lifting straps (DIN EN 1492-1) and/or clamp-bands (DIN EN 12195-2) must be used.

If mounting position IM V1 is ordered, eyebolts are supplied for vertical mounting.

The motors are designated in accordance with the types of construction on the rating plate.

With motors that have a vertical shaft extension, the end user must prevent an ingress of fluid along the shaft.

In the case of all types of construction with shaft extension down, the version “with protective cover” is urgently recommended, see the section “Degrees of protection”, Page 0/119.

#### Frame design

Motors in the types of construction with feet have, in some cases, two fixing holes at the feet at the non-drive end (NDE), see dimension tables, Pages 1/68 to 1/75. A code is cast into the motor close to the fixing retaining holes to identify the frame size.

A metal fan cover is used as standard for horizontal types of construction and types of constructions with shaft extension facing upwards (14th position of Order No. letter **A, T, U, V, D, F, H, J, K, L** or **N**) in combination with condensation drainage holes, order code **H03**.

<sup>1)</sup> A second shaft extension **L05** is not possible.

# IEC Squirrel-Cage Motors

## Introduction motors 1LE1/1PC1

### General technical data

0

#### Mechanical design and degrees of protection

##### Preparation for gear mounting

The flange-mounting motors can be equipped with a radial seal in order to mount gearing.

Order code **H23**

It must be ensured that the sealing ring is lubricated using grease, oil mist or oil spray (it is not permissible to use pressurized oil > 0.1 bar).

We recommend that the admissible bearing loads are carefully checked.

##### Eyebolts and transport

1LE1/1PC1 motors without feet have four cast eyebolts as standard, each offset by 90°; in the case of screwed-on feet, two eyebolts are covered by the feet, so in this case only two eyebolts are available for use.

##### Frame material

Type series	Frame size	Frame material	Frame feet
<b>1LE1/1PC1</b>	100 ... 160	Aluminum alloy	Cast <sup>1)</sup>

##### Preparation for mountings

The encoders of the “modular and special technology” can be fitted at a later time. The motor must be prepared for this. Possible for all 1LE1 motors (with the exception of 1LE1 with option F90 – version “Forced-air cooled motors without external fan and fan cover”).

For the brake with order code F01 and for all encoders from the “modular and special technology”, this preparation of the shaft extension on NDE can be ordered with the option “Prepared for mounting, only center hole”.

Order code **G40**

The length of the motor does not change because the shaft extension is still under the fan cover.

For the encoders

- 1XP8 012-10 order code G01
- 1XP8 012-20 order code G02

from the “modular technology”, this preparation of the shaft extension on NDE can be ordered with the option “Prepared for mounting with shaft D12”.

Order code **G41**

By using option **G41**, the motor length increases by dimension  $\Delta l$ . For explanations of additional dimensions and weights, see “Technology”, “Dimensions and weights” from Page 0/137.

For the encoders

- LL 861 900 220 order code G04
- HOG 9 D 1024 I order code G05
- HOG 10 D 1024 I order code G06

from the “special technology”, this preparation of the shaft extension on NDE can be ordered with the option “Prepared for mounting with shaft D16”.

Order code **G42**

By using option **G42**, the motor length increases by dimension  $\Delta l$ . For explanations of additional dimensions and weights, see “Technology”, “Dimensions and weights” from Page 0/137.

Motors that are prepared for additional mountings (order codes G40, G41, G42) are supplied without protective cover as standard.

If a protective cover is requested as cover or as mechanical protection for mounting provided by the customer, it can be ordered with order code **G43**. It must be mounted according to the supplied installation instructions. The protective cover has supports of different lengths that, depending on the height of the mounting, can be used during the installation.

The standard protective cover (order code **H00**) is not suitable for protecting additional mountings such as the rotary pulse encoder.

The order codes **G40**, **G41** and **G42** are not possible in combination with order code **L00**, vibration quantity level B.

<sup>1)</sup> Basic version, cast feet: Special version “Screwed-on feet (instead of cast)” with digit **5**, **6** and **7** in the 16th position of the Order No. or digit **4** with order code **H01**. Screwed-on feet are standard for motors with increased output.



# IEC Squirrel-Cage Motors

## Introduction motors 1LE1/1PC1

### General technical data

0

#### Degrees of protection

All motors are designed to IP55 degree of protection. They can be installed in dusty or humid environments. The motors are suitable for operation in tropical climates. Guide value <60 % relative air humidity at CT 40 °C. Other requirements are available on request.

#### Brief explanation of the degree of protection

**IP55:** Protection against harmful dust deposits, protection against water jets from any direction.

#### IP56 (non-heavy-sea):

Protection against harmful dust deposits, protection against water jets from any direction.

#### Order code H22

DIN EN 60034-5 defines protection level 6 for water protection as: "Protection against water due to heavy seas or water in a powerful jet". IP56 non-heavy-sea degree of protection can only be used with the requirement "Protection against a powerful jet" and not for the requirement "Protection against heavy sea".

Not possible in combination with brake 2LM8 (order code **F01**).

**IP65:** Complete protection against dust deposits, protection against water jets from any direction.

#### Order code H20

In DIN EN 60034-5, the code 6 for protection against the ingress of foreign bodies and touch hazard protection for electrical machines is not listed – data for code 6 (protection against the ingress of dust) is given in EN 60529.

Not possible in combination with rotary pulse encoder HOG 9 D 1024I (order code **G05**) and/or brake 2LM8 (order code **F01**) and/or in combination with option "unpainted, only cast iron parts primed" (**S00**).

DIN EN 60529 contains a comprehensive description of this degree of protection as well as test conditions.

With motors that have a vertical shaft extension, the end user must prevent an ingress of fluid along the shaft.

For motors with shaft extension pointing downwards, the version "protective cover for types of construction", order code **H00**, is urgently recommended, see also "Types of construction", Page 0/116.

With flange-mounting motors, for IM V3 type of construction, collection of fluid in the flange basin can be prevented by drainage holes (on request).

The condensation drainage holes at the drive end (DE) and non-drive end (NDE) are sealed (IP55) on delivery. If the condensation drainage holes are ordered for motors to the IM B6, IM B7 or IM B8 type of construction (feet located on side or top), the position of the drainage holes will be in the correct position for the type of construction.

#### Order code H03

A metal fan cover is used as standard for horizontal types of construction and types of constructions with shaft extension facing upwards (14<sup>th</sup> position of Order No. letter **A, T, U, V, D, F, H, J, K, L** or **N**) in combination with condensation drainage holes, order code **H03**, to facilitate mounting/demounting.

When the motors are used or stored outdoors we recommend that they are kept under some sort of cover so that they are not subjected to direct intensive solar radiation, rain, snow, ice or dust over a long period of time. In such cases, technical consultation may be appropriate.

When the motors are used outdoors or in a corrosive environment, it is recommended that non-rusting screws are used externally.

#### Order code H07

#### Vibration-proof version

A load of 1.5 g in all 3 planes for up to 1 % of the service life of the motor is possible.

#### Order code H02

For availability of individual options for the relevant motor series, see section "Special versions" in catalog part 1.

#### Noise levels for mains-fed operation

The noise levels are measured in accordance with DIN EN ISO 1680 in a dead room. It is specified as the A-valued measuring-surface sound pressure level  $L_{pFA}$  in dB (A).

This is the spatial mean value of the sound pressure levels measured on the measuring surface. The measuring surface is a cube 1 m away from the surface of the motor. The sound power level is also specified as  $L_{WA}$  in dB (A).

The specified values are valid at 50 Hz at rated output (see the Selection and ordering data). The tolerance is +3 dB. At 60 Hz, the values are approximately 4 dB (A) higher. Please inquire about the noise levels for motors with converter-fed operation.

To reduce noise levels, 2-pole motors with frame size 132 S can be fitted with an axial-flow fan that is only suitable for one direction of rotation. The values can be taken from the table "Low-noise version" below.

#### Clockwise rotation

#### Order code F77

#### Counter-clockwise rotation

#### Order code F78

A second shaft extension and/or mountings (mounting of brake, external fan, or encoder) are not possible.

#### Low-noise version

Type series	Frame size	2-pole motors	
		$L_{pFA}$ dB (A)	$L_{WA}$ dB (A)
<b>1LE1</b> <sup>1)</sup>	132	60	72
	160	60	72

<sup>1)</sup> With the exception of 1LE1 with option F90 – version "Forced-air cooled motors without external fan and fan cover".

# IEC Squirrel-Cage Motors

## Introduction motors 1LE1/1PC1

### General technical data

0

#### Balance and vibration quantity

All of the rotors are dynamically balanced with an inserted half key. This corresponds to vibration quantity level A (normal/standard). The vibrational characteristics and behavior of electrical machinery is specified in DIN EN 60034-14 Sept. 2004. Based on DIN ISO 8821, the key convention "half key" (H) must be used for balancing.

The type of key convention used for balancing is stamped on the face of the DE/NDE.

- F = Balancing with full key  
(Full-key convention)
- H = Balancing with half key  
(Half-key convention) – standard
- N = Balancing without key –  
Plain text required (Convention without key)

This is indicated on the rating plate of motors up to frame size 112. Full-key balancing or balancing with full-key (F) is possible on request with order code **L02** (additional charge).

Balancing without featherkey (N) is possible on request by specifying code **L01** (additional charge).

Vibration quantity level A is the standard version and is valid for a rated frequency of 60 Hz.

Low-vibration version B can be supplied to fulfill stricter requirements on smooth running (additional charge).

Vibration quantity level B  
Not possible with parallel roller bearings.

Order code **L00**

The order code **L00** vibration quantity level B is not possible in combination with order codes **G40**, **G41** and **G42**.

The limits stated in the table are applicable for uncoupled, idling motors in free suspension.

For converter-fed operation with frequencies greater than 60 Hz, special balancing is required for compliance with the specified limit values (plain text: max. supply frequency/speed).

For further details, see the online help in the SD configurator (available soon).

Limits (rms values) for max. vibration quantity of vibration distance (s), vibration speed (v) and acceleration (a) for the shaft height H											
Vibration quantity level	Machine installation	Shaft height H in mm									
		56 ≤ H ≤ 132			132 < H ≤ 280			H > 280			
		$s_{rms}$ μm	$v_{rms}$ mm/s	$a_{rms}$ mm/s <sup>2</sup>	$s_{rms}$ μm	$v_{rms}$ mm/s	$a_{rms}$ mm/s <sup>2</sup>	$s_{rms}$ μm	$v_{rms}$ mm/s	$a_{rms}$ mm/s <sup>2</sup>	
A	Free suspension	25	1.6	2.5	35	2.2	3.5	45	2.8	4.4	
	Rigid clamping	21	1.3	2.0	29	1.8	2.8	37	2.3	3.6	
B	Free suspension	11	0.7	1.1	18	1.1	1.7	29	1.8	2.8	
	Rigid clamping	–	–	–	14	0.9	1.4	24	1.5	2.4	

For details, see standard DIN EN 60034-14, Sept. 2004.

# IEC Squirrel-Cage Motors

## Introduction motors 1LE1/1PC1

### General technical data

0

#### Shaft and rotor

##### Shaft extension

60° center hole to DIN 332, Part 2 with M3 to M24 tapped hole depending on the shaft diameter (see dimension tables, Pages 1/68 to 1/75.)

Second standard shaft extension.

Order code **L05**

Possible for all 1LE1 motors (with the exception of 1LE1 with option F90 – version “Forced-air cooled motors without external fan and fan cover”).

The second shaft extension can transmit the full rated output via coupling output.

Please also inquire about the transmitted power and admissible cantilever force if belt pulleys, chains or gear pinions are used on the second shaft extension.

A second shaft extension is not available if a rotary pulse encoder and/or separately driven fan is mounted. Please inquire if a brake is mounted.

DE (shaft extension)	
Diameter mm	Thread mm
7 ... 10	DR M3
>10 ... 13	DR M4
>13 ... 16	DR M5
>16 ... 21	DR M6
>21 ... 24	DR M8
>24 ... 30	DR M10
>30 ... 38	DR M12
>38 ... 50	DS M16
>50 ... 85	DS M20
>85 ... 130	DS M24

Dimensions and tolerances for keyways and keys are designed to DIN EN 50347. The motors are always supplied with a key inserted in the shaft.

##### Admissible changes to the shaft extension:

Motor series	Frame size	Shaft extension length E in mm		Shaft extension diameter D in mm	
		Standard	Up to max.	Standard	Up to max. <sup>1)</sup>
<b>1LE1, 1PC1</b>	100	60	120	28	30
	112				
	132	80	160	38	40
	160	110	220	42	45

##### Shaft extension with standard dimensions, without featherkey way

For motor series 1LE1 and 1PC1, the standard shaft extension can be ordered with standard dimensions without featherkey way.

Order code **L04**

##### Standard shaft made of non-rusting steel

For motor series 1LE1, a standard shaft made of non-rusting steel can be ordered. This is only possible for shaft extensions of standard dimensions. For non-standard shaft dimensions, there will be an additional charge!

Order code **L06**

Please inquire about other non-rusting materials.

##### Non-standard cylindrical shaft extension

The non-standard cylindrical shaft extension can be used on the drive end (DE) or non-drive end (NDE). The featherkey is always supplied with it.

Order code **Y55**

When motors are ordered which have a longer or shorter shaft extension as standard, the required position and length of the featherkey way must be specified in a sketch. It must be ensured that only featherkeys in accordance with DIN 6885, Form A are permitted to be used. The location of the featherkey way is in the center of the shaft extension. The length is defined by the manufacturer normatively.

Not valid for: Conical shafts, non-standard threaded journals, non-standard shaft tolerances, friction welded journals, extremely “thin” shafts, special geometry dimensions (e.g. square journals, etc.), hollow shafts.

For order code **Y55** and second standard shaft extension **L05** (see previous page):

- Dimensions D and DA must be less than or equal to the inner diameter of the roller bearing (see dimension tables under “Dimensions” in catalog part 1)
- Dimensions E and EA must be smaller than or equal to 2 x length E (standard) of the shaft extension

A non-standard cylindrical shaft extension can be supplied for the motor series listed in the table “Admissible changes to shaft extension” below up to the specified maximum lengths and diameters as compared to the standard shaft.

It is the responsibility of the customer to ensure that the admissible cantilever forces are reduced in accordance with the non-standard shaft extension.

##### Concentricity of shaft extension, coaxiality and linear movement in accordance with DIN 42955 Tolerance R for flange-mounting motors

The following are specified in DIN 42955 with Tolerance N (normal) and Tolerance R (reduced):

1. Concentricity tolerances for the shaft extension
2. Coaxiality tolerances for the shaft extension and flange centering
3. Linear movement tolerances for the shaft extension and flange surface

The concentricity of the shaft extension, coaxiality and linear movement according to DIN 42955 Tolerance R for flange-mounting motors can be ordered using order code **L08**. This order code can be combined for motors with deep-groove bearings of series 60.., 62.. and 63... This cannot be supplied in combination with brake or encoder mounting.

Concentricity of the shaft extension can be ordered according to DIN 42955 Tolerance R for types of construction without flange with order code **L07**.

<sup>1)</sup> At maximum admissible diameter, a step increase in shaft diameter is not possible.

# IEC Squirrel-Cage Motors

## Introduction motors 1LE1/1PC1

### General technical data

0

#### Bearings and lubrication

##### Bearing lifetime (nominal lifetime)

The nominal bearing lifetime is defined acc. to standardized calculation procedures (DIN ISO 281) and is reached or even exceeded for 90 % of the bearings when the motors are operated in compliance with the data provided in the catalog.

Under average operating conditions, a lifetime ( $L_{h10}$ ) of 100 000 hours can be achieved.

Generally, the bearing lifetime is defined by the bearing size, the bearing load, the operating conditions, the speed and the grease lifetime.

##### Bearing system

The bearing lifetime of motors with horizontal type of construction is at least 40 000 hours if there is no additional axial loading at the coupling output and at least 20 000 hours with the maximum admissible loads.

This assumes that the motor is operated at 50 Hz. The nominal bearing lifetime is reduced for converter-fed operation at higher frequencies.

For the admissible vibration values measured at the bearing plate, evaluation zones A and B specified in ISO 10816 are applicable in order to achieve the calculated lifetime under continuous duty. If higher vibration speeds will occur under the operating conditions, special arrangements will be necessary (please inquire).

In the basic bearing system, the floating bearing is situated at the drive end (DE) and the located bearing is situated at the non-drive end (NDE).

The bearing system is axially preloaded with a spring element at the drive end (DE) to ensure smooth running of the motor without play. (see Figure 1 of the Diagrams of bearings, Page 0/124).

For frame size 160 and above, the located bearing is axially secured at the non-drive end (NDE). Up to frame size 132, an additional axially-secured located bearing can be supplied on the non-drive end (NDE) complete with a retaining ring (see Figure 2 of the Diagrams of bearings, Page 0/124).  
Order code **L21**

On request, the located bearing can also be supplied at the drive end (DE) (see Figure 3 of the Diagrams of bearings, Page 0/124).  
Order code **L20**

For increased cantilever forces (e.g. belt drives), reinforced bearings can be used at the drive end (DE).  
Order code **L22**

Motors 1LE1/1PC1 can be supplied with reinforced deep-groove bearings at both ends (size range 03). Special bearings for DE and NDE, bearing size 63, the bearing plates are manufactured from cast-iron for this purpose.  
Order code **L25**

A measuring nipple for SPM shock pulse measurement is mounted to check bearing vibration. The motors have a tapped hole for each bearing plate and a measuring nipple with a protective plug. If a second tapped hole is provided, it is fitted with a sealing plug.  
Order code **Q01**

Bearing selection for increased cantilever forces (see the table "Bearing selection for 1LE1/1PC1 motors – Bearing for increased cantilever forces", Page 0/124) – "Admissible axial load" from Page 0/126.

##### Permanent lubrication

For permanent lubrication, the bearing grease lifetime is matched to the bearing lifetime. This can, however, only be achieved if the motor is operated in accordance with the catalog specifications.

In the basic version, the motors have permanent lubrication.

##### Regreasing

For motors which can be regreased at defined regreasing intervals, the bearing lifetime can be extended and/or unfavorable factors such as temperature, mounting conditions, speed, bearing size and mechanical load can be compensated.

It is possible to regrease motors, shaft heights 100 to 160. A lubricating nipple is optionally provided.  
Order code **L23**

For motors with regreasing device, data concerning regreasing intervals, grease quantity, type of grease and, where applicable, additional data are stated on the rating plate or lubricating plate. For regreasing intervals for basic versions see table "Grease lifetime and regreasing intervals for horizontal installation". The regreasing device cannot be mounted in combination with mounting of the brake, order code F01.

##### Mechanical stress and grease lifetime

High speeds that exceed the rated speed with converter-fed operation and the resulting increased vibrations alter the mechanical running smoothness and the bearings are subjected to increased mechanical stress. This reduces the grease lifetime and the bearing lifetime (please inquire where applicable).

For converter-fed operation in particular, compliance with the mechanical limit speeds  $n_{max}$  at maximum supply frequency  $f_{max}$  is essential, see the following table "Mechanical limit speeds  $n_{max}$  at maximum supply frequency  $f_{max}$ ".

# IEC Squirrel-Cage Motors

## Introduction motors 1LE1/1PC1

### General technical data

0

Mechanical limit speeds  $n_{max}$  at maximum supply frequency  $f_{max}$  (standard values)

Motor frame size	2-pole		4-pole		6-pole		8-pole	
	$n_{max}$ rpm	$f_{max}$ Hz	$n_{max}$ rpm	$f_{max}$ Hz	$n_{max}$ rpm	$f_{max}$ Hz	$n_{max}$ rpm	$f_{max}$ Hz
<b>1LE1/1PC1</b>								
100 L	6000	100	4200	140	3600	180	3000	200
112 M	6000	100	4200	140	3600	180	3000	200
132 S/M	5600	90	4200	140	3600	180	3000	200
160 M/L	4800	80	4200	140	3600	180	3000	200

Grease lifetime and regreasing intervals for **horizontal** installation

<b>Permanent lubrication <sup>1)</sup></b>			
Type series	Frame size	Number of poles	Grease lifetime up to CT 40 °C <sup>2)</sup>
<b>1LE1/1PC1</b>	100 ... 160	2 to 8	20000 h or 40000 h <sup>3)</sup>
<b>Regreasing (basic version) <sup>1)</sup></b>			
Type series	Frame size	Number of poles	Regreasing interval up to CT 40 °C <sup>2)</sup>
<b>1LE1/1PC1</b>	100 ... 160	2 to 8	8000 h

<sup>1)</sup> For special uses and special greases, please inquire about grease lifetime and regreasing intervals.

<sup>2)</sup> If the coolant temperature is increased by 10 K, the grease lifetime and regreasing interval are halved.

<sup>3)</sup> 40000 h apply to horizontally installed motors with coupling output without additional axial loads.

# IEC Squirrel-Cage Motors

## Introduction motors 1LE1/1PC1

### General technical data

0

#### Bearing selection table for 1LE1/1PC1 motors – basic version

The bearing selection tables are only intended for planning purposes. Authoritative information on the actual type of bearings fitted in motors already supplied can be obtained by the factory by quoting the serial number or can be read from the rating plate.

When deep-groove ball bearings with side plates are used, the side plate is on the inside. Located bearing at drive end (DE) for 1LE1/1PC1 motors, see special version Figure 2 in the “Diagrams of bearings”, below on this page.

For motors frame size	Number of poles	Drive end (DE) bearing		Non-drive end (NDE) bearing		Figure, below on this page
		Horizontal type of construction	Vertical type of construction	Horizontal type of construction	Vertical type of construction	
<b>1LE1/1PC1</b>						
100 L	2 to 8	6206 2ZC3	6206 2ZC3	6206 2ZC3	6206 2ZC3	<b>Fig. 1</b>
112 M	2 to 8	6206 2ZC3	6206 2ZC3	6206 2ZC3	6206 2ZC3	<b>Fig. 1</b>
132 S/M	2 to 8	6208 2ZC3 <sup>1)</sup>	6208 2ZC3 <sup>1)</sup>	6208 2ZC3 <sup>1)</sup>	6208 2ZC3 <sup>1)</sup>	<b>Fig. 1</b>
160 M/L	2 to 8	6209 2ZC3 <sup>1)</sup>	6209 2ZC3 <sup>1)</sup>	6209 2ZC3 <sup>1)</sup>	6209 2ZC3 <sup>1)</sup>	<b>Fig. 2</b>

#### Bearing selection table for 1LE1/1PC1 motors – Bearings for increased cantilever forces – Order code **L22**

Please inquire about noise and vibration data. The bearing selection tables are only intended for planning purposes. Authoritative information on the actual type of bearings fitted in motors already supplied can be obtained by the factory by quoting the

serial number or can be read from the rating plate. When deep-groove ball bearings with side plates are used, the side plate is on the inside.

For motors frame size	Number of poles	Drive end (DE) bearing		Non-drive end (NDE) bearing		Figure, below on this page
		Horizontal type of construction	Vertical type of construction	Horizontal type of construction	Vertical type of construction	
<b>1LE1/1PC1</b>						
100 L	2 to 8	6306 2ZC3 <sup>1)</sup>	6306 2ZC3 <sup>1)</sup>	6206 2ZC3 <sup>1)</sup>	6206 2ZC3 <sup>1)</sup>	<b>Fig. 1</b>
112 M	2 to 8	6306 2ZC3 <sup>1)</sup>	6306 2ZC3 <sup>1)</sup>	6206 2ZC3 <sup>1)</sup>	6206 2ZC3 <sup>1)</sup>	<b>Fig. 1</b>
132 S/M	2 to 8	6308 2ZC3 <sup>1)</sup>	6308 2ZC3 <sup>1)</sup>	6208 2ZC3 <sup>1)</sup>	6208 2ZC3 <sup>1)</sup>	<b>Fig. 1</b>
160 M/L	2 to 8	6309 2ZC3 <sup>1)</sup>	6309 2ZC3 <sup>1)</sup>	6209 2ZC3 <sup>1)</sup>	6209 2ZC3 <sup>1)</sup>	<b>Fig. 2</b>

#### Bearing selection table for 1LE1/1PC1 motors – Deep-groove bearings reinforced at both ends – Order code **L25**

Please inquire about noise and vibration data. The bearing selection tables are only intended for planning purposes. Authoritative information on the actual type of bearings fitted in motors already supplied can be obtained by the factory by quoting the

serial number or can be read from the rating plate. When deep-groove ball bearings with side plates are used, the side plate is on the inside.

For motors frame size	Number of poles	Drive end (DE) bearing		Non-drive end (NDE) bearing		Figure, below on this page
		Horizontal type of construction	Vertical type of construction	Horizontal type of construction	Vertical type of construction	
<b>1LE1/1PC1</b>						
100 L	2 to 8	6306 2ZC3 <sup>1)</sup>	6306 2ZC3 <sup>1)</sup>	6306 2ZC3 <sup>1)</sup>	6306 2ZC3 <sup>1)</sup>	<b>Fig. 1</b>
112 M	2 to 8	6306 2ZC3 <sup>1)</sup>	6306 2ZC3 <sup>1)</sup>	6306 2ZC3 <sup>1)</sup>	6306 2ZC3 <sup>1)</sup>	<b>Fig. 1</b>
132 S/M	2 to 8	6308 2ZC3 <sup>1)</sup>	6308 2ZC3 <sup>1)</sup>	6308 2ZC3 <sup>1)</sup>	6308 2ZC3 <sup>1)</sup>	<b>Fig. 1</b>
160 M/L	2 to 8	6309 2ZC3 <sup>1)</sup>	6309 2ZC3 <sup>1)</sup>	6309 2ZC3 <sup>1)</sup>	6309 2ZC3 <sup>1)</sup>	<b>Fig. 2</b>

#### Diagrams of bearings

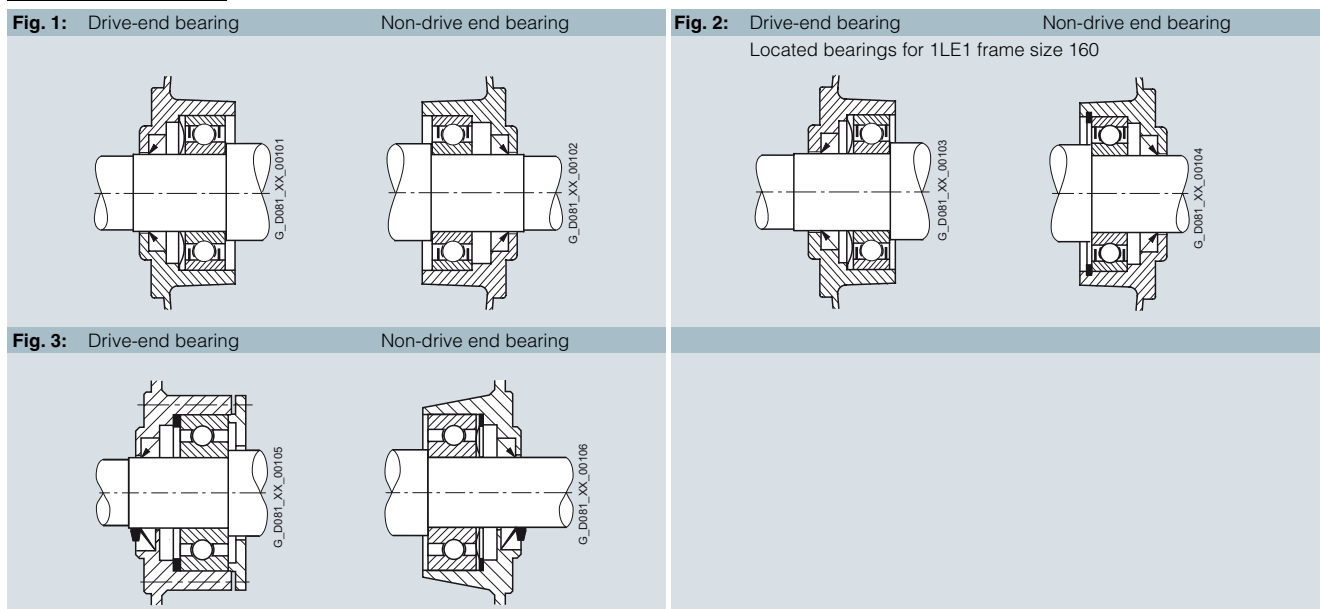

<sup>1)</sup> Bearings with a side plate are used for regreasable versions (order code **L23**).

# IEC Squirrel-Cage Motors

## Introduction motors 1LE1/1PC1

### General technical data

#### Admissible cantilever forces

#### Admissible cantilever forces, basic version

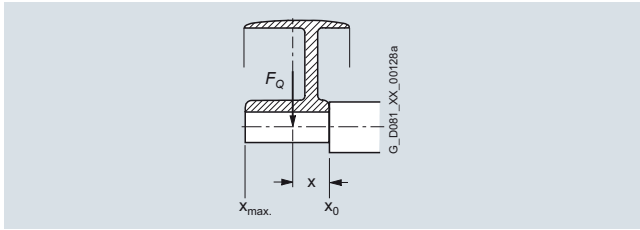

In order to calculate the admissible cantilever forces for a radial load, the line of force (i.e. the centerline of the pulley) of the cantilever force  $F_Q$  (N) must lie within the free shaft extension (dimension X).

Dimension x [mm] is the distance between the point of application of force  $F_Q$  and the shaft shoulder. Dimension  $x_{max}$  corresponds to the length of the shaft extension.

Total cantilever force  $F_Q = c \cdot F_u$

The pre-tension factor c is a value gained from experience from the belt manufacturer. The following approximate value can be assumed:

For normal flat leather belts with an idler pulley  $c = 2$ ;  
for V-belts  $c = 2$  to 2.5;  
for special synthetic belts (depending on the type of load and type of belt)  $c = 2$  to 2.5.

The circumferential force  $F_u$  (N) is calculated using the following equation

$$F_u = 2 \cdot 10^7 \frac{P}{n \cdot D}$$

$F_u$  circumferential force in N  
 $P$  rated motor output (transmitted power) in kW  
 $n$  fan speed in rpm  
 $D$  belt pulley diameter in mm

The pulleys are standardized acc. to DIN 2211, Sheet 3.

The admissible cantilever forces at 60 Hz are approx. 80 % of the 50 Hz values (please inquire).

It should be observed that for types of construction IM B6, IM B7, IM B8, IM V5 and IM V6 the belt tension is only permitted to act parallel to the mounting plane or towards the mounting plane and the feet must be supported. Both feet must be secured for foot-mounting types of construction.

Refer to "Bearing design for increased cantilever forces", Page 0/126.

#### Admissible cantilever forces for the basic 50 Hz version

Valid are:  $x_0$  values for  $x = 0$  and  $x_{max}$  values für  $x = l$  ( $l$  = shaft extension)

Frame size	Order No.	Number of poles	Admissible cantilever force	
			at $x_0$ Type	at $x_{max}$ . Type
			N	N

#### 1LE1 motor values for EFF1 motors with increased output <sup>1)</sup> (Self-ventilated motors with increased output and high efficiency):

100	<b>1LE1001-1AA</b>	2	1010	825
	<b>1LE1001-1AB</b>	4	1230	1010
	<b>1LE1001-1AC</b>	6	1440	1180
112	<b>1LE1001-1BA</b>	2	970	785
	<b>1LE1001-1BB</b>	4	1235	1000
	<b>1LE1001-1BC</b>	6	1440	1165
132	<b>1LE1001-1CA</b>	2	1470	1180
	<b>1LE1001-1CB</b>	4	1830	1470
	<b>1LE1001-1CC</b>	6	2150	1730
160	<b>1LE1001-1DA</b>	2	1550	1270
	<b>1LE1001-1DB</b>	4	1910	1550
	<b>1LE1001-1DC</b>	6	2230	1810

#### Admissible cantilever forces for the basic 50 Hz version

Valid are:  $x_0$  values for  $x = 0$  and  $x_{max}$  values für  $x = l$  ( $l$  = shaft extension)

Frame size	Order No.	Number of poles	Admissible cantilever force	
			at $x_0$ Type	at $x_{max}$ . Type
			N	N

#### 1LE1 motors, standard values for EFF1 motors <sup>1)</sup> (Self-ventilated energy-saving motors with high efficiency/ Forced-air cooled motors without external fan and fan cover with high efficiency)

#### 1PC1 motors, standard values for EFF1 motors <sup>1)</sup> (Self-cooled motors with high efficiency):

100	<b>1LE1001-1AA</b>	2	1020	815
	<b>1PC1001-1AA</b>			
	<b>1LE1001-1AB</b>	4	1250	1000
	<b>1PC1001-1AB</b>			
	<b>1LE1001-1AC</b>	6	1450	1155
	<b>1PC1001-1AC</b>			
	<b>1LE1001-1AD</b>	8	1615	1290
	<b>1PC1001-1AD</b>			
112	<b>1LE1001-1BA</b>	2	1000	790
	<b>1PC1001-1BA</b>			
	<b>1LE1001-1BB</b>	4	1250	990
	<b>1PC1001-1BB</b>			
	<b>1LE1001-1BC</b>	6	1450	1150
	<b>1PC1001-1BC</b>			
	<b>1LE1001-1BD</b>	8	1610	1275
	<b>1PC1001-1BD</b>			
132	<b>1LE1001-1CA</b>	2	1505	1170
	<b>1PC1001-1CA</b>			
	<b>1LE1001-1CB</b>	4	1880	1460
	<b>1PC1001-1CB</b>			
	<b>1LE1001-1CC</b>	6	2170	1680
	<b>1PC1001-1CC</b>			
	<b>1LE1001-1CD</b>	8	2420	1880
	<b>1PC1001-1CD</b>			
160	<b>1LE1001-1DA</b>	2	1560	1240
	<b>1PC1001-1DA</b>			
	<b>1LE1001-1DB</b>	4	2040	1590
	<b>1PC1001-1DB</b>			
	<b>1LE1001-1DC</b>	6	2350	1820
	<b>1PC1001-1DC</b>			
	<b>1LE1001-1DD</b>	8	2610	2030
	<b>1PC1001-1DD</b>			

<sup>1)</sup> The admissible cantilever force load of EFF2 motors can be increased by up to 5 %.

# IEC Squirrel-Cage Motors

## Introduction motors 1LE1/1PC1

### General technical data

#### Bearing design for increased cantilever forces

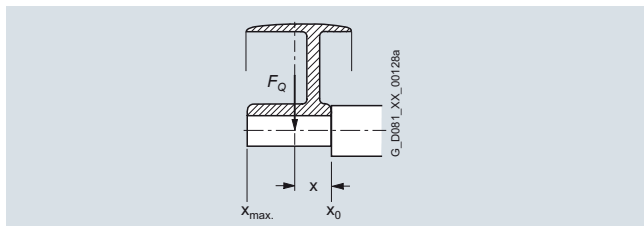

It should be observed that for types of construction IM B6, IM B7, IM B8, IM V5 and IM V6 the belt tension is only permitted to act parallel to the mounting plane or towards the mounting plane and the feet must be supported. Both feet must be secured for foot-mounted types of construction.

#### Admissible cantilever forces for the basic 50 Hz version Deep-groove ball bearings at the drive end (DE) – Order code L22 Valid are: $x_0$ values for $x = 0$ and $x_{max}$ . values für $x = l$ ( $l$ = shaft extension)

Frame size	Order No.	Number of poles	Admissible cantilever force	
			at $x_0$	at $x_{max}$ .
			Type	Type
			N	N

#### 1LE1 motor values for EFF 1 motors with increased output <sup>1)</sup> (Self-ventilated motors with increased output and high efficiency):

100	<b>1LE1001-1AA</b>	2	1585	1300
	<b>1LE1001-1AB</b>	4	1960	1610
	<b>1LE1001-1AC</b>	6	2270	1865
112	<b>1LE1001-1BA</b>	2	1545	1250
	<b>1LE1001-1BB</b>	4	1960	1585
	<b>1LE1001-1BC</b>	6	2270	1835
132	<b>1LE1001-1CA</b>	2	2285	1840
	<b>1LE1001-1CB</b>	4	2860	2300
	<b>1LE1001-1CC</b>	6	3320	2670
160	<b>1LE1001-1DA</b>	2	2800	2240
	<b>1LE1001-1DB</b>	4	3450	2270
	<b>1LE1001-1DC</b>	6	4000	3200

#### Admissible cantilever forces for the basic 50 Hz version

##### Deep-groove ball bearings at the drive end (DE) – Order code L22

Valid are:  $x_0$  values for  $x = 0$  and  $x_{max}$ . values für  $x = l$  ( $l$  = shaft extension)

Frame size	Order No.	Number of poles	Admissible cantilever force	
			at $x_0$	at $x_{max}$ .
			Type	Type
			N	N

#### 1LE1 motors standard values for EFF1 motors <sup>1)</sup> (Self-ventilated energy-saving motors with high efficiency/ Forced-air cooled motors without external fan and fan cover with high efficiency) 1PC1 motors, standard values for EFF1 motors <sup>1)</sup> (Self-cooled motors with high efficiency):

100	<b>1LE1001-1AA</b>	2	1590	1270
	<b>1PC1001-1AA</b>			
	<b>1LE1001-1AB</b>	4	1970	1575
	<b>1PC1001-1AB</b>			
	<b>1LE1001-1AC</b>	6	2270	1815
	<b>1PC1001-1AC</b>			
	<b>1LE1001-1AD</b>	8	2520	2015
	<b>1PC1001-1AD</b>			
112	<b>1LE1001-1BA</b>	2	1565	1240
	<b>1PC1001-1BA</b>			
	<b>1LE1001-1BB</b>	4	1965	1555
	<b>1PC1001-1BB</b>			
	<b>1LE1001-1BC</b>	6	2270	1800
	<b>1PC1001-1BC</b>			
	<b>1LE1001-1BD</b>	8	2510	1990
	<b>1PC1001-1BD</b>			
132	<b>1LE1001-1CA</b>	2	2310	1795
	<b>1PC1001-1CA</b>			
	<b>1LE1001-1CB</b>	4	2900	2250
	<b>1PC1001-1CB</b>			
	<b>1LE1001-1CC</b>	6	3330	2580
	<b>1PC1001-1CC</b>			
	<b>1LE1001-1CD</b>	8	3700	2870
	<b>1PC1001-1CD</b>			
160	<b>1LE1001-1DA</b>	2	2810	2170
	<b>1PC1001-1DA</b>			
	<b>1LE1001-1DB</b>	4	3540	2750
	<b>1PC1001-1DB</b>			
	<b>1LE1001-1DC</b>	6	4070	3160
	<b>1PC1001-1DC</b>			
	<b>1LE1001-1DD</b>	8	4510	3500
	<b>1PC1001-1DD</b>			

#### Admissible axial load

#### 1LE1 motors in vertical type of construction – basic version (except motors with increased output)

Frame size	Shaft extension pointing															
	3000 rpm				1500 rpm				1000 rpm				750 rpm			
	downwards		upwards		downwards		upwards		downwards		upwards		downwards		upwards	
	Load down	Load up	Load down	Load up	Load down	Load up	Load down	Load up	Load down	Load up	Load down	Load up	Load down	Load up	Load down	Load up
100	140	700	550	280	130	990	820	285	130	1280	1110	285	130	1560	1390	285
112	140	710	550	300	130	1000	820	310	130	1290	1110	310	130	1570	1390	310
132	200	1200	950	470	180	1680	1200	470	180	1900	1600	470	190	2200	1900	440
160	1500	1400	950	1900	1900	1800	1300	2200	2200	2200	1600	2700	2700	2700	1950	2900

The values shown do not assume a cantilever force on the shaft extension.  
The admissible loads are valid for operation at 50 Hz; for 60 Hz, please inquire.

The calculation of the admissible axial load was based on the drive with generally available coupling. For suppliers, see the relevant section of the catalog, section "Accessories", Page 1/64.  
Please inquire if the load direction alternates.

<sup>1)</sup> The admissible cantilever force load of EFF2 motors can be increased by up to 5 %.



# IEC Squirrel-Cage Motors

## Introduction motors 1LE1/1PC1

### General technical data

#### 1LE1/1PC1 motors in horizontal type of construction – basic version (except motors with increased output)

Frame size	3000 rpm				1500 rpm				1000 rpm				750 rpm			
	Ten-sile load	Thrust load (N) with radial load at			Ten-sile load	Thrust load (N) with radial load at			Ten-sile load	Thrust load (N) with radial load at			Ten-sile load	Thrust load (N) with radial load at		
		$x_0$	$x_{max.}$	without radial load		$x_0$	$x_{max.}$	without radial load		$x_0$	$x_{max.}$	without radial load		$x_0$	$x_{max.}$	without radial load
N	N	N	N	N	N	N	N	N	N	N	N	N	N	N	N	N
100	220	450	350	630	220	600	500	910	220	650	550	1200	220	750	650	1480
112	220	450	350	630	220	600	500	910	220	650	550	1200	220	750	650	1480
132	350	650	520	1200	350	850	700	1600	350	1020	890	1900	350	1150	1020	2200
160	1500	850	720	1500	1500	1050	920	1800	1500	1250	1120	2200	1500	1350	1220	2600

The values shown do not assume a cantilever force on the shaft extension.

The admissible loads are valid for operation at 50 Hz; for 60 Hz, please inquire.

The calculation of the admissible axial load was based on the drive with generally available coupling. For suppliers, see the relevant section of the catalog "Accessories", Page 1/64. Please inquire if the load direction alternates.

#### Modular technology

##### Basic versions

The range of potential applications for the 1LE1 motors (with the exception of 1LE1 with option F90 – version "Forced-air cooled motors without external fan and fan cover" and 1PC1) can be broadened considerably by mounting the following modules (e.g. as brake motors).

- **1XP8 012** rotary pulse encoder
- Separately driven fan
- Brake

The brake must always be mounted in the factory for safety reasons. The rotary pulse encoder and/or the separately driven fan can also be retrofitted.

The degree of protection of the motors with modular technology is IP55. Higher degrees of protection on request.

When a rotary pulse encoder, brake or separately driven fan is mounted, the length of the motor increases by  $\Delta l$ . For an explanation of the additional dimensions and weights, see "Technology", "Dimensions and weights" from Page 0/137.

# IEC Squirrel-Cage Motors

## Introduction motors 1LE1/1PC1

### General technical data

0

#### 1XP8 012 rotary pulse encoder

The rotary pulse encoder can be supplied already mounted in an HTL version as **1XP8 012-10** with order code **G01** or in a TTL version as **1XP8 012-20** with order code **G02**. The rotary pulse encoder can only be mounted on a standard non-drive end (NDE), i.e. a second shaft extension cannot be supplied.

The encoder can be retrofitted. The motor must be prepared for this. When the motor is ordered, the option "Prepared for mountings, center hole only", order code **G40**, or the option "Prepared for mountings with shaft D12", order code **G41**, must be specified (see "Mechanical design and degrees of protection", Page 0/118).

The 1XP8 012 rotary pulse encoder is suitable for standard applications. For further encoders, see "Special technology", Page 0/134.

When the rotary pulse encoder is mounted, the length of the motor increases by  $\Delta l$ . For an explanation of the additional dimensions and weights, see "Technology", "Dimensions and weights" from Page 0/137.

The rotary pulse encoders of "Modular technology" and "Special technology" are fitted as standard with a protective cover made of non-corrosive sheet steel.

Mounting of encoder at temperatures below  $-20\text{ °C}$  and higher than  $+40\text{ °C}$  on request.

#### Technical data of rotary pulse encoders

	<b>1XP8 012-10</b> (HTL version) +10 V to +30 V	<b>1XP8 012-20</b> (TTL version) 5V $\pm$ 10 %
Supply voltage $U_B$		
Current input without load	150 mA	120 mA
Admissible load current per output	max. 100 mA	max. 20 mA
Pulses per revolution	1024	1024
Outputs	2 square-wave pulses A, B – 2 inverted square-wave pulses A, B Zero pulse and inverted zero pulse	
Pulse offset between the two outputs	90°	90°
Output amplitude	$U_{\text{High}} = U_B - 2.5\text{ V}$ $U_{\text{Low}} = 1.6\text{ V}$	$U_{\text{High}} > 2.5\text{ V}$ $U_{\text{Low}} < 0.5\text{ V}$
Edge interval	$\geq 0.43\text{ }\mu\text{s}$	$\geq 0.43\text{ }\mu\text{s}$
Sampling rate	$\leq 300\text{ kHz}$	$\leq 300\text{ kHz}$
Maximum speed	6000 rpm	6000 rpm
Transportation/storage temperature range	$-30\text{ to }+80\text{ °C}$	$-30\text{ to }+80\text{ °C}$
Operating temperature range flange socket or fixed cable	$-40\text{ to }+100\text{ °C}$	$-40\text{ to }+100\text{ °C}$
Operating temperature range flexible cable	$-10\text{ to }+100\text{ °C}$	$-10\text{ to }+100\text{ °C}$
Degree of protection	IP66	IP66
Maximum admissible radial cantilever force	60 N	60 N
Maximum admissible axial force	40 N	40 N
Connection system	12-pin connector (mating connector is supplied)	
Certification	CSA, UL	CSA, UL
Weight	0.3 kg	0.3 kg

# IEC Squirrel-Cage Motors

## Introduction motors 1LE1/1PC1

### General technical data

0

#### Separately driven fan

The use of a separately driven fan is recommended to increase motor utilization at low speeds and to limit noise generation at speeds significantly higher than the synchronous speed. Both of these results can only be achieved with converter-fed operation. Please inquire about traction and vibratory operation.

The separately driven fan can be supplied already fitted, order code **F70**.

It can also be ordered separately and retrofitted. For selection information and order numbers, see the section "Accessories" (available soon). A rating plate listing all the important data is fitted to the separately driven fan. Please note the direction of rotation of the separately driven fan (axial-flow fan) when connecting it. Admissible coolant temperatures  $CT_{min.}$   $-25\text{ °C}$ ,  $CT_{max.}$   $+65\text{ °C}$ <sup>1)</sup>, lower/higher coolant temperatures on request. When the separately driven fan is mounted, the length of the motor increases by  $\Delta$  l. For an explanation of the additional dimensions and weights, see "Technology", "Dimensions and weights" from Page 0/137.

#### Technical data of the separately driven fan (acc. to DIN EN 60034-1 Tolerance)

Frame size	Rated voltage range		Frequency	Rated speed	Power consumption	Rated current
	V		Hz	rpm	kW	A
100	1 AC	230 to 277	50	2790	0.075	0.29
	3 AC	220 to 290 $\Delta$	50	2830	0.086	0.27
	3 AC	380 to 500 Y	50	2830	0.086	0.16
	1 AC	230 to 277	60	3280	0.094	0.28
	3 AC	220 to 332 $\Delta$	60	3490	0.093	0.27
	3 AC	380 to 575 Y	60	3490	0.093	0.16
112	1 AC	230 to 277	50	2720	0.073	0.26
	3 AC	220 to 290 $\Delta$	50	2770	0.085	0.27
	3 AC	380 to 500 Y	50	2770	0.085	0.15
	1 AC	230 to 277	60	3000	0.107	0.31
	3 AC	220 to 332 $\Delta$	60	3280	0.094	0.28
	3 AC	380 to 575 Y	60	3280	0.094	0.16
132	1 AC	230 to 277	50	2860	0.115	0.40
	3 AC	220 to 290 $\Delta$	50	2880	0.138	0.45
	3 AC	380 to 500 Y	50	2880	0.138	0.24
	1 AC	230 to 277	60	3380	0.185	0.59
	3 AC	220 to 332 $\Delta$	60	3470	0.148	0.41
	3 AC	380 to 575 Y	60	3470	0.148	0.24
160	1 AC	230 to 277	50	2780	0.236	0.96
	3 AC	220 to 290 $\Delta$	50	2840	0.220	0.76
	3 AC	380 to 500 Y	50	2830	0.220	0.43
	3 AC	220 to 332 $\Delta$	60	3400	0.284	0.94
	3 AC	380 to 575 Y	60	3400	0.284	0.56

<sup>1)</sup> The admissible coolant temperature for single phase versions (1 AC) for frame size 160 is  $CT_{max.}$   $+50\text{ °C}$ .

# IEC Squirrel-Cage Motors

## Introduction motors 1LE1/1PC1

### General technical data

0

#### Brakes

Spring-operated disk brakes are used for the brakes with order code **F01**. When the brake is ordered, the supply voltage must be specified. The supply voltage for brakes is explained under "Modular technology – Additional versions", Page 0/133.

For the design of each brake type, the braking time, run-on revolutions, braking energy per braking procedure as well as the service life of the brake linings, see "Configuration of motors with brakes", Page 0/132.

When a brake is mounted, the length of the motor increases by  $\Delta l$ . For an explanation of the additional dimensions and weights, see "Technology", "Dimensions and weights" from Page 0/137.

*The brake can be retrofitted by authorized partners. The motor must be prepared for this. When the motor is ordered, the option "Prepared for mountings, center hole only", order code G40, must be specified (see "Mechanical design and degrees of protection", Page 0/118).*

#### 2LM8 spring-operated disk brake

The 2LM8 brake has IP55 degree of protection.

Please inquire if motors with brakes are to be operated below the freezing point or in very humid environments (e.g. close to the sea) with long standstill times. Please inquire if the brake motors are used for converter-fed operation with low speeds.

#### Design and mode of operation

The brake takes the form of a single-disk brake with two friction surfaces.

The braking torque is generated by friction when pressure is applied by one or more pressure springs in the de-energized state. The brake is released electromagnetically.

When the motor brakes, the rotor which can be axially shifted on the hub or the shaft is pressed via the armature disk against the friction surface by means of the springs. In the braked state, there is a gap  $S_{\text{Gap}}$  between the armature disk and the solenoid component. To release the brake, the solenoid is energized with DC voltage. The resulting magnetic force pulls the armature disk against the spring force on to the solenoid component. The spring force is then no longer applied to the rotor which can rotate freely.

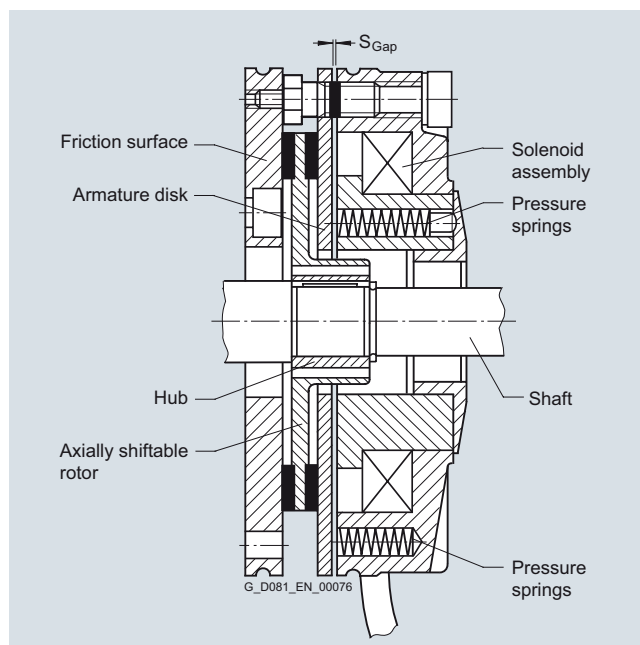

Design of the 2LM8 spring-operated disk brake

#### Rating plate

The following brake data are specified on the motor rating plate.

Brake type, supply voltage, frequency, current, temperature class, braking torque

#### Operating values for spring-operated brakes with standard excitation

For motor Frame size	Brake type	Rated braking torque at 100 rpm	Rated braking torque at 100 rpm in % at the following speeds			Supply voltage	Current/power input <sup>1)</sup>			Brake application time $t_2$ <sup>2)</sup>	Brake release time	Brake moment of inertia	Noise level $L_p$ with rated air gap	Service capability of the brake	
			1500 rpm	3000 rpm	Max. speed		V	A	W					Lifetime of brake lining $L$	Air gap adjustment required after braking energy $L_N$
		Nm	%	%	%	V	A	W	ms	ms	kgm <sup>2</sup>	dB (A)	Nm · 10	Nm · 10	
100	<b>2LM8 040-5NA10</b>	40	81	74	66	AC 230	0.2	40	43	140	0.00036	80	1350	115	
	<b>2LM8 040-5NA60</b>					AC 400	0.22								
	<b>2LM8 040-5NA80</b>					DC 24	1.67								
112	<b>2LM8 060-6NA10</b>	60	80	73	65	AC 230	0.25	53	60	210	0.00063	77	1600	215	
	<b>2LM8 060-6NA60</b>					AC 400	0.28								
	<b>2LM8 060-6NA80</b>					DC 24	2.1								
132	<b>2LM8 100-7NA10</b>	100	79	72	65	AC 230	0.27	55	50	270	0.0015	77	2450	325	
	<b>2LM8 100-7NA60</b>					AC 400	0.31								
	<b>2LM8 100-7NA80</b>					DC 24	2.3								
160	<b>2LM8 260-8NA10</b>	260	75	68	65	AC 230	0.5	100	165	340	0.0073	79	7300	935	
	<b>2LM8 260-8NA60</b>					AC 400	0.47								
	<b>2LM8 260-8NA80</b>					DC 24	4.2								

<sup>1)</sup> For 400 V AC and for 24 V DC, the power can deviate by up to +10 % as a result of the selected supply voltage.

<sup>2)</sup> The specified switching times are valid for switching on the DC side with a rated release travel and with the coil already warm. They are average values which may vary depending on factors such as the rectifier type and the release travel. The brake application time for switching on the AC side, for example, is approximately 6 times longer than for switching on the DC side.

# IEC Squirrel-Cage Motors

## Introduction motors 1LE1/1PC1

### General technical data

0

#### Lifetime of the brake lining

The braking energy  $L_N$  up to when the brake should be adjusted, depends on various factors. The main influencing factors include the masses to be braked, the operating speed, the switching frequency and therefore the temperature at the frictional surfaces. It is therefore not possible to specify a value for the friction energy until readjustment that is valid for all operating conditions.

When used as operating brake, the specific frictional surface wear (wear volume for the frictional work) is approximately 0.05 up to 2 cm<sup>3</sup>/kWh.

#### Maximum admissible speeds

The maximum admissible speeds from which emergency stops can be made, are listed in the next table. These speeds should be considered as recommended values and must be checked under actual operating conditions.

The maximum admissible friction energy depends on the switching frequency and is shown for the individual brakes in the following diagram. Increased wear can be expected when the brakes are used for emergency stops.

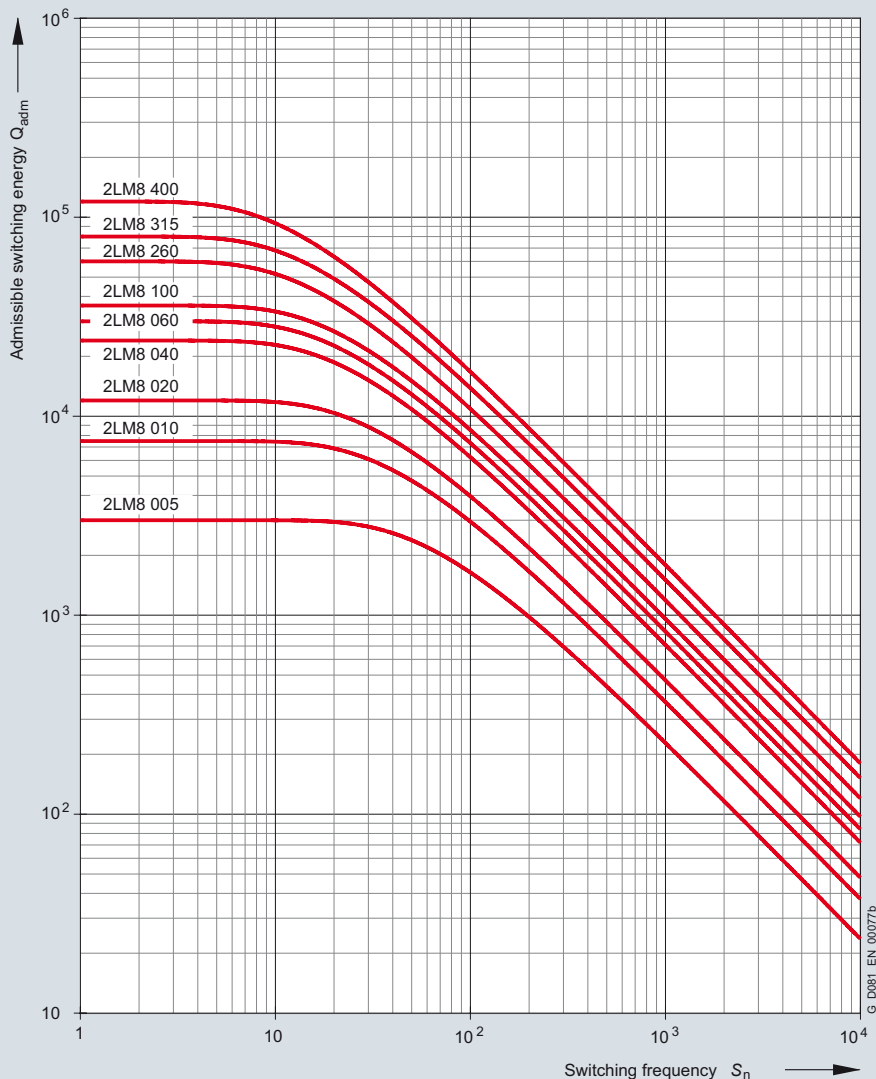

For motor Frame size	Brake type	Maximum admissible speeds			Changing the braking torque			Readjusting the air gap		
		Max. adm. operating speed if max. adm. operating energy utilized	Max. adm. no-load speed with emergency stop function	Horizontal mounting	Vertical mounting	Reduction per notch	Dimension "O1"	Min. brak- ing torque	Rated air gap $S_{Gap \text{ Rated}}$	Maximum air gap $S_{Gap \text{ max.}}$
100	<b>2LM8 040-5NA . .</b>	3000	6000	6000	1.29	12.5	21.3	0.3	0.65	8.0
112	<b>2LM8 060-6NA . .</b>	3000	6000	6000	1.66	11.0	32.8	0.3	0.75	7.5
132	<b>2LM8 100-7NA . .</b>	3000	5300	5000	1.55	13.0	61.1	0.3	0.75	8.0
160	<b>2LM8 260-8NA . .</b>	1500	4400	3200	5.6	17.0	157.5	0.4	1.2	12.0

# IEC Squirrel-Cage Motors

## Introduction motors 1LE1/1PC1

### General technical data

0

#### Changing the braking torque

The brake is supplied with the braking torque already set. For 2LM8 brakes, the torque can be reduced to the dimension  $O_1$  by unscrewing the adjusting ring with a hook spanner. The braking torque changes by the values shown in the above table for each notch of the adjusting ring.

#### Readjusting the air gap

Under normal operating conditions, the brake is practically maintenance-free. The air gap  $S_{\text{Gap}}$  must only be checked at regular intervals if the application requires an extremely large amount of frictional energy and readjusted to the rated gap  $S_{\text{Gap rated}}$  at the latest when the maximum air gap  $S_{\text{Gap max.}}$  is reached.

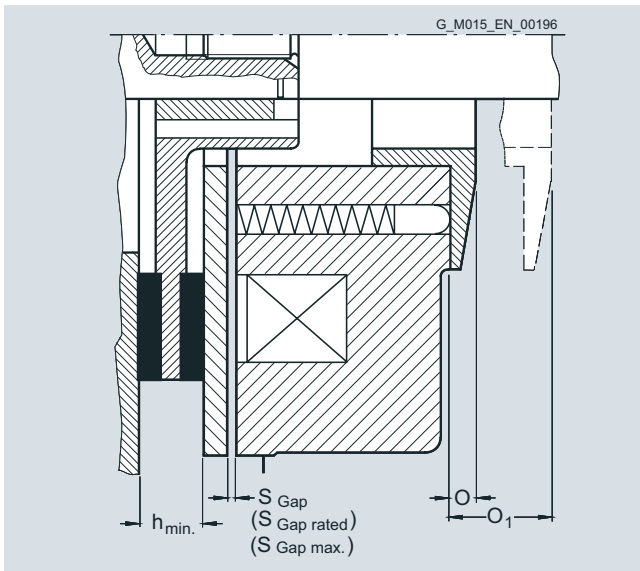

#### Configuration of motors with brakes

##### Braking time

The time it takes the motor to come to a standstill comprises two components:

- The application time of the brake  $t_2$
- The braking time  $t_{\text{Br}}$

$$t_{\text{Br}} = \frac{J \cdot n_{\text{rated}}}{9.55 \cdot (T_{\text{B}} \pm T_{\text{L}})}$$

$t_{\text{Br}}$	Braking time in s
$J$	Total moment of inertia in $\text{kgm}^2$
$n_{\text{rated}}$	Rated speed of the motor with brake in rpm
$T_{\text{B}}$	Rated braking torque in Nm
$T_{\text{L}}$	Average load torque in Nm (if $T_{\text{L}}$ supports braking, $T_{\text{L}}$ is positive)

#### Braking energy per braking operation $Q_{\text{adm}}$

The braking energy per braking operation in Nm comprises the energy of the moments of inertia to be braked  $Q_{\text{Kin}}$  and the energy  $Q_{\text{L}}$ , which must be applied in order to brake against a load torque:

$$Q_{\text{adm}} = Q_{\text{Kin}} + Q_{\text{L}}$$

- The energy of the moments of inertia in Nm

$$Q_{\text{Kin}} = \frac{J \cdot n_{\text{rated}}^2}{182.4}$$

$n_{\text{rated}}$  Rated speed before braking in rpm  
 $J$  Total moment of inertia in  $\text{kg m}^2$

- The braking energy in Nm against a load torque

$$Q_{\text{L}} = \frac{\pm T_{\text{L}} \cdot n_{\text{rated}} \cdot t_{\text{Br}}}{19.1}$$

$T_{\text{L}}$  average load torque in Nm  
 $T_{\text{L}}$  is positive if it acts against the brake  
 $T_{\text{L}}$  is negative if it supports the brake

#### Run-on revolutions $U$

The number of run-on revolutions  $U$  of the motor with brake can be calculated as follows:

$$U = \frac{n_{\text{rated}}}{60} \left( t_2 + \frac{t_{\text{Br}}}{2} \right)$$

$t_2$  Brake application time in ms

#### Lifetime of the brake lining $L$ and readjustment of the air gap

The brake lining wears due to friction which increases the air gap and the release time for the brake at standard excitation.

When the brake lining is worn out, it can be replaced easily.

In order to calculate the lifetime of the brake lining in terms of operations  $S_{\text{max}}$ , the lifetime of the brake lining  $L$  in Nm must be divided by the braking energy  $Q_{\text{adm}}$ :

$$S_{\text{max}} = \frac{L}{Q_{\text{adm}}}$$

The interval between adjustments  $N$  in switching frequencies can be calculated in terms of operations by dividing the braking energy  $L_{\text{N}}$  which the brake can output until it is necessary to re-adjust the working air gap by  $Q_{\text{adm}}$ :

$$N = \frac{L_{\text{N}}}{Q_{\text{adm}}}$$

# IEC Squirrel-Cage Motors

## Introduction motors 1LE1/1PC1

### General technical data

0

#### Additional versions

#### 2LM8 spring-operated disk brake

##### Motor series

This brake is mounted on 1LE1 motors as standard (with the exception of 1LE1 with order code F90 – version “Forced-air cooled motors without external fan and fan cover”, and 1PC1).

##### Voltage and frequency

The solenoid coil and the brake rectifier can be connected to the following voltages or can be supplied for the following voltages:

- Brake supply voltage: 24 V DC  
Order code **F10**
- Brake supply voltage: 230 V AC  
Order code **F11**
- Brake supply voltage: 400 V AC  
(directly at the terminal strip)  
Order code **F12**

**When 60 Hz is used, the voltage for the brake must not be increased!**

Order codes **F10**, **F11** and **F12** may only be used in conjunction with order code **F01**.

##### Connections

Labeled terminals are provided in the main connection box of the motor to connect the brake.

The AC voltage for the brake excitation winding is connected to the two free terminals of the rectifier block (~).

The brake can be released when the motor is at a standstill by separately exciting the solenoid. In this case, an AC voltage must be connected at the rectifier block terminals. The brake remains released as long as this voltage is present.

The rectifier is protected against overvoltages by varistors in the input and output circuits.

For 24 V DC brakes, the brake terminals are directly connected to the DC voltage source.

See the circuit diagrams below.

##### Fast brake application

If the brake is disconnected from the line supply, the brake is applied. The application time for the brake disk is delayed as a result of the inductance of the solenoid (shutdown on the AC side). This results in a considerable delay before the brake is mechanically applied. In order to achieve short brake application times, the circuit must be interrupted on the DC side. To realize this, the wire jumpers, located between contacts 1+ and 2+ at the rectifier are removed and replaced by the contacts of an external switch (see circuit diagrams below).

##### Manual brake release with lever

The brakes can be supplied with a mechanical manual release with lever.

Order code **F50**.

The dimensions of the brake lever depend on the motor frame size and can be read from the dimension drawing generator for motors in the SD configurator tool for low-voltage motors.

#### Bridge rectifier / half-wave rectifier

Brakes are connected through a standard bridge or half-wave rectifier or directly to the 2LM8 brake. See the circuit diagrams below.

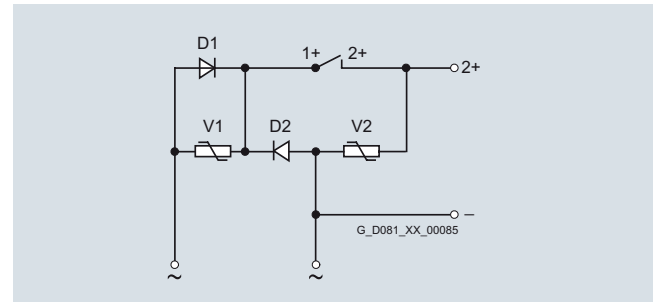

Half-wave rectifier, 400 V AC

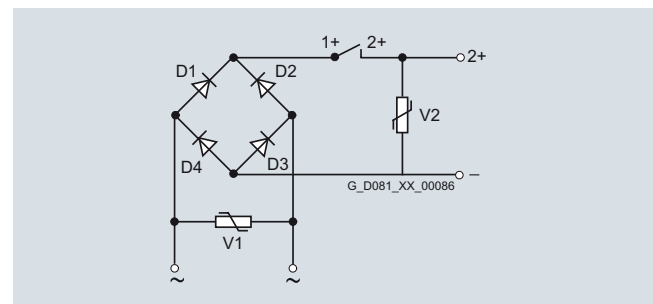

Bridge rectifier, 230 V AC

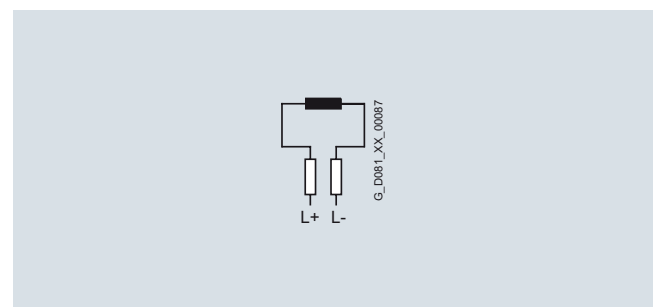

Brake connection for 24 V DC

# IEC Squirrel-Cage Motors

## Introduction motors 1LE1/1PC1

### General technical data

0

#### Special technology

The range of "Special technology" comprises rotary pulse encoders for the 1LE1 motors (with the exception of 1LE1 with order code F90 – version "Forced-air cooled motors without external fan and fan cover", and 1PC1).

The 1LE1 motors with the order codes **F70** (mounted separately driven fan), **F01** (mounted brake) and **F01 + F70** (mounted brake and separately driven fan) from the "Modular technology" range can be combined with the LL 861 900 200, HOG 9 D 1024 I and HOG 10 D 1024 I rotary pulse encoders from the "Special technology" range.

When a rotary pulse encoder is mounted, the length of the motor increases by  $\Delta$  l. For an explanation of the additional dimensions and weights, see "Technology", "Dimensions and weights" from Page 0/137.

The rotary pulse encoders of "Modular technology" and "Special technology" are fitted as standard with a protective cover made of non-corrosive sheet steel.

#### Rotary pulse encoder LL 861 900 220



With its rugged construction, this rotary pulse encoder is also suitable for difficult operating environments. It is resistant to shock and vibration and has insulated bearings.

The LL 861 900 220 rotary pulse encoder can be supplied already mounted.

Order code **G04**.

*The LL 861 900 220 rotary pulse encoder can be retrofitted. The motor must be prepared for this. When the motor is ordered, the option "Prepared for mountings, center hole only", order code **G40**, or the option "Prepared for mountings with shaft D16", order code **G42**, must be specified (see "Mechanical design and degrees of protection", Page 0/118). The rotary pulse encoder is not part of the scope of supply in this case.*

The version of the rotary pulse encoder with a diagnostics system (ADS) can be supplied by Leine and Linde.

Manufacturer:  
Leine and Linde (Deutschland) GmbH  
Bahnhofstraße 36  
73430 Aalen  
Tel. +49 (0) 73 61-78093-0  
Fax +49 (0) 73 61-78093-11

<http://www.leinelinde.com>  
e-mail: [info@leinelinde.se](mailto:info@leinelinde.se)

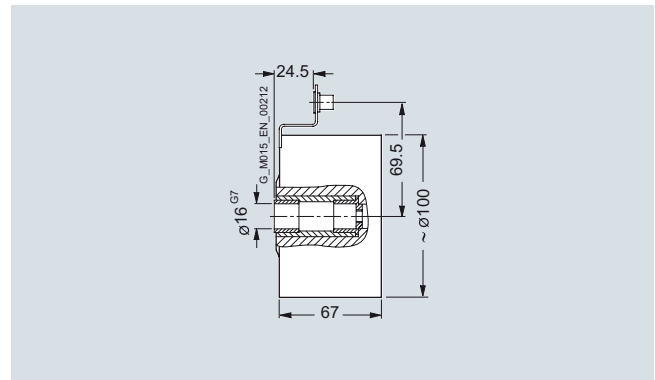

Mounting dimensions of rotary pulse encoder LL 861 900 220

#### Technical data for LL 861 900 220 (HTL version)

Mounting of encoder at temperatures below  $-20\text{ °C}$  and higher than  $+40\text{ °C}$  on request.

Supply voltage $U_B$	+9 V to +30 V
Current input without load	max. 80 mA
Admissible load current per output	40 mA
Pulses per revolution	1024
Outputs	6 short-circuit proof square-wave pulses A, A', B, B', 0, 0'
Pulse offset between the two outputs	$90^\circ \pm 25^\circ$ el.
Output amplitude	$U_{\text{High}} > 20\text{ V}$ $U_{\text{Low}} < 2.5\text{ V}$
Mark space ratio	1:1 $\pm 10\%$
Edge steepness	50 V/ $\mu\text{s}$ (without load)
Maximum frequency	100 kHz for 350 m cable
Maximum speed	4000 rpm
Temperature range	$-20$ to $+80\text{ °C}$
Degree of protection	IP65
Maximum adm. radial cantilever force	300 N
Maximum adm. axial force	100 N
Connection system	Terminal strips in encoder Cable connection M20 x 1.5 radial
Weight	Approx. 1.3 kg



# IEC Squirrel-Cage Motors

## Introduction motors 1LE1/1PC1

### General technical data

0

#### HOG 9 D 1024 rotary pulse encoder



The encoder is fitted with insulated bearings.

The HOG 9 D 1024 I rotary pulse encoder can be supplied already mounted.  
Order code **G05**.

The HOG 9 D 1024 I rotary pulse encoder can be retrofitted. The motor must be prepared for this. When the motor is ordered, the option "Prepared for mountings, center hole only", order code **G40**, or the option "Prepared for mountings with shaft D16", order code **G42**, must be specified (see "Mechanical design and degrees of protection", Page 0/118). The rotary pulse encoder is not part of the scope of supply in this case.

Manufacturer:  
Baumer Hübner GmbH  
Planufer 92b  
10967 Berlin  
Tel. +49 (0) 30-6 90 03-0  
Fax +49 (0) 30-6 90 03-1 04

<http://www.baumerhuebner.com>  
e-mail: [info@baumerhuebner.com](mailto:info@baumerhuebner.com)

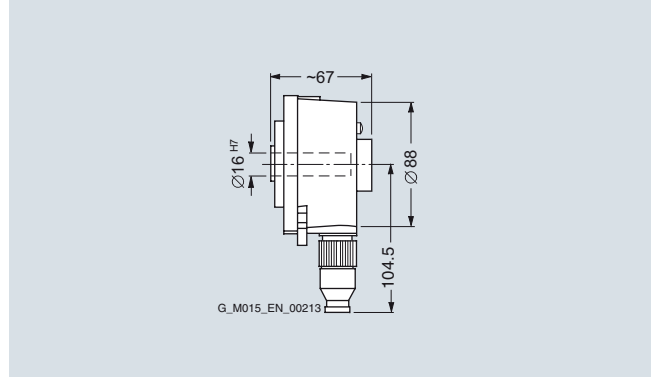

Mounting dimensions for HOG 9 D 1024 I rotary pulse encoder

Technical data for HOG 9 D 1024 (TTL version)

Mounting of encoder at temperatures below  $-20\text{ °C}$  and higher than  $+40\text{ °C}$  on request.

Supply voltage $U_B$	+9 V to +30 V
Current input without load	50 mA to 100 mA
Admissible load current per output	60 mA, 300 mA peak
Pulses per revolution	1024
Outputs	4 short-circuit proof square-wave pulses A, B and A', B'
Pulse offset between the two outputs	$90^\circ \pm 20\%$
Output amplitude	$U_{\text{High}} \geq U_B - 3.5\text{ V}$ $U_{\text{Low}} \leq 1.5\text{ V}$
Mark space ratio	$1:1 \pm 20\%$
Edge steepness	10 V/ $\mu\text{s}$
Maximum frequency	120 kHz
Maximum speed	7000 rpm
Temperature range	$-20\text{ to }+100\text{ °C}$
Degree of protection	IP56
Maximum adm. radial cantilever force	150 N
Maximum adm. axial force	100 N
Connection system	Radial right-angle plug (mating connector is part of the scope of supply)
Mech. design acc. to Hübner Ident. No.	73 522 B
Weight	Approx. 0.9 kg

# IEC Squirrel-Cage Motors

## Introduction motors 1LE1/1PC1

### General technical data

0

#### HOG 10 D 1024 I rotary pulse encoder



This encoder is extremely rugged and is therefore suitable for difficult operating conditions. It is fitted with insulated bearings.

The HOG 10 D 1024 I rotary pulse encoder can be supplied already mounted.

Order code **G06**.

*The HOG 10 D 1024 I rotary pulse encoder can be retrofitted. The motor must be prepared for this. When the motor is ordered, the option "Prepared for mountings, center hole only", order code **G40**, or the option "Prepared for mountings with shaft D16", order code **G42**, must be specified (see "Mechanical design and degrees of protection", Page 0/118). The rotary pulse encoder is not part of the scope of supply in this case.*

Manufacturer:

Baumer Hübner GmbH  
Planufer 92b  
10967 Berlin  
Tel. +49 (0) 30-6 90 03-0  
Fax +49 (0) 30-6 90 03-1 04

<http://www.baumerhuebner.com>  
e-mail: [info@baumerhuebner.com](mailto:info@baumerhuebner.com)

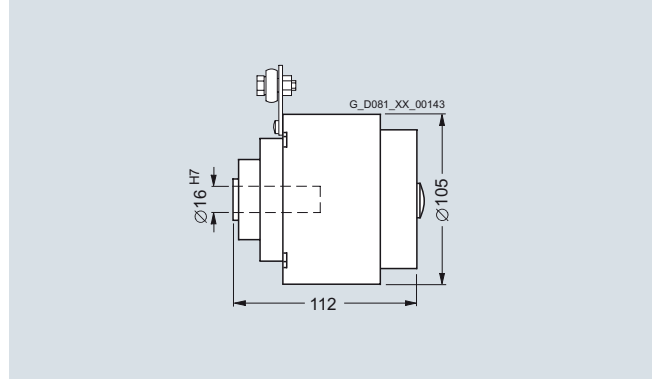

Mounting dimensions for HOG 10 D 1024 I rotary pulse encoder

*Technical data for HOG 10 D 1024 (HTL version)*

Mounting of encoder at temperatures below  $-20\text{ °C}$  and higher than  $+40\text{ °C}$  on request.

Supply voltage $U_B$	+9 V to +30 V
Current input without load	Approx. 100 mA
Admissible load current per output	60 mA, 300 mA peak
Pulses per revolution	1024
Outputs	4 short-circuit proof square-wave pulses A, B and A', B'
Pulse offset between the two outputs	$90^\circ \pm 20\%$
Output amplitude	$U_{High} \geq U_B - 3.5\text{ V}$ $U_{Low} \leq 1.5\text{ V}$
Mark space ratio	$1:1 \pm 20\%$
Edge steepness	10 V/ $\mu\text{s}$
Maximum frequency	120 kHz
Maximum speed	7000 rpm
Temperature range	$-20\text{ to }+100\text{ °C}$
Degree of protection	IP66
Maximum adm. radial cantilever force	150 N
Maximum adm. axial force	80 N
Connection system	Terminals, cable connection M20 x 1.5
Mech. design acc. to Hübner Ident. No.	74 055 B
Weight	Approx. 1.6 kg

### Dimensions and weight

**Fig. 1** Brake  
Order code **F01**  
[optionally with manual release, order code **F50**]

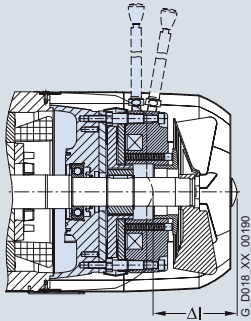

**Fig. 2** Standard protective cover for types of construction  
Order code **H00**

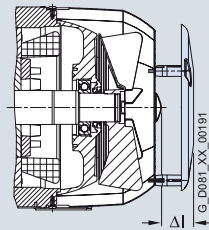

**Fig. 3** Rotary pulse encoder (on cover)  
Order code **G01/G02/G04/G05/G06**  
[protective cover as standard]

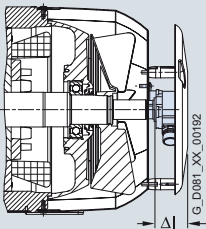

**Fig. 4** Brake and rotary pulse encoder (on cover)  
Order code **F01**  
**+ G01/G02/G04/G05/G06**  
[optionally with manual release, order code **F50**;  
protective cover as standard]

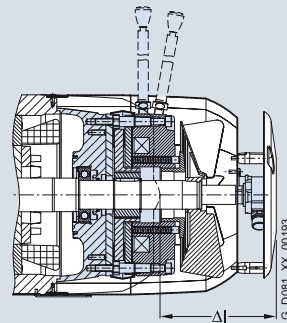

**Fig. 5** Separately driven fan  
Order code **F70**

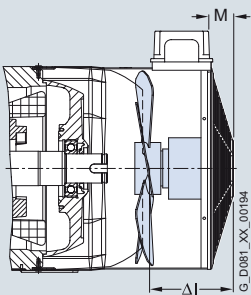

**Fig. 6** Brake and separately driven fan  
Order code **F01 + F70**  
[optionally with manual release, order code **F50**]

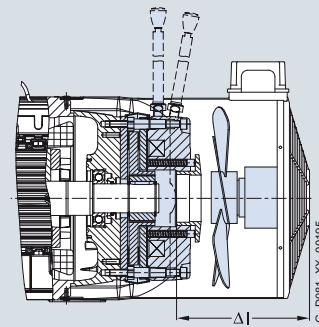

# IEC Squirrel-Cage Motors

## Introduction motors 1LE1/1PC1

### General technical data

0

**Fig. 7** Rotary pulse encoder (under the cover) and separately driven fan  
Order code **F70**  
+ **G01/G02/G04/G05/G06**

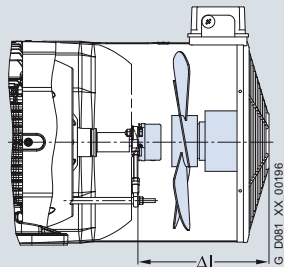

**Fig. 8** Brake, rotary pulse encoder (under the cover) and separately driven fan  
Order code **F01 + F70**  
+ **G01/G02/G04/G05/G06**  
[optionally with manual release, order code **F50**]

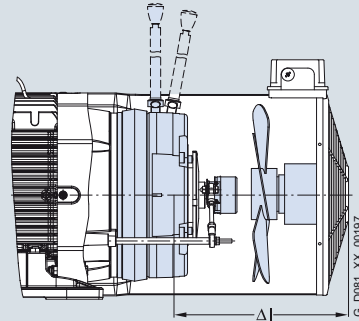

**Fig. 9** Protective cover for separately driven fan  
Order code **H00**

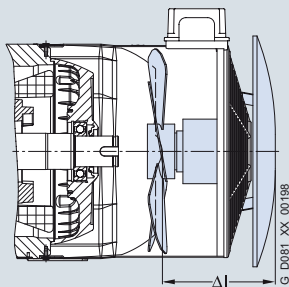

**Fig. 10** Prepared for mountings – only center hole  
(for brake order code **F01** and/or rotary pulse encoder  
order codes **G01/G02/G04/G05/G06**)  
Order code **G40**

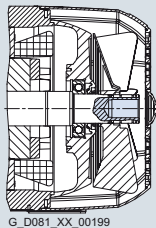

**Fig. 11** Prepared for mountings with shaft D12/D16  
Order codes **G41/G42**

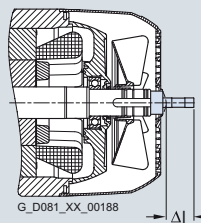

Dimensions  $\Delta l$  and weights, see from Page 0/139.

# IEC Squirrel-Cage Motors

## Introduction motors 1LE1/1PC1

### General technical data

0

Assignment												
Frame size	Fig. 1				Fig. 2				Fig. 3			
	Brake				Protective cover				Rotary pulse encoder including protective cover			
	Order code F01		Order code H00		Order codes G01, G02		Order code G04		Order code G05		Order code G06	
	Δl	Weight approx.	Δl	Weight approx.	Δl	Weight approx.	Δl	Weight approx.	Δl	Weight approx.	Δl	Weight approx.
	mm	kg	mm	kg	mm	kg	mm	kg	mm	kg	mm	kg
<b>1LE1</b>												
100	81	5.9	33	0.4	49	0.9	76	1.9	76	1.5	119	2.2
112	88	7.8	33	0.4	49	0.8	76	1.9	76	1.5	119	2.2
132	114	11.9	51.5	0.7	51.5	1.3	78.5	2.4	78.5	2	121.5	2.7
160	130	30.7	50	0.7	50	1.5	77	2.7	77	2.3	120	3

Assignment												
Frame size	Fig. 4								Fig. 5			
	Brake and rotary pulse encoder (on cover)								Separately driven fan			
	Order codes F01 + G01/G02		Order codes F01 + G04		Order codes F01 + G05		Order codes F01 + G06		Order code F70			
	Δl	Weight approx.	Δl	Weight approx.	Δl	Weight approx.	Δl	Weight approx.	Δl	M	Weight approx.	
	mm	kg	mm	kg	mm	kg	mm	kg	mm	mm	kg	
<b>1LE1</b>												
100	130	6.8	157	7.8	157	7.4	200	8.1	86.5	30	2.4	
112	137	8.6	164	9.7	164	9.3	207	10	81.5	30	2.6	
132	165.5	13.2	192.5	14.3	192.5	13.9	235.5	14.6	116	40	3.8	
160	180	32.2	207	33.4	207	33	250	33.7	135.5	40	6.5	

Assignment												
Frame size	Fig. 6				Fig. 7							
	Brake and separately driven fan				Separately driven fan and rotary pulse encoder (under cover)							
	Order codes F01 + F70		Order codes F70 + G01/G02		Order codes F70 + G04		Order codes F70 + G05		Order codes F70 + G06			
	Δl	Weight approx.	Δl	Weight approx.	Δl	Weight approx.	Δl	Weight approx.	Δl	Weight approx.		
	mm	kg	mm	kg	mm	kg	mm	kg	mm	kg		
<b>1LE1</b>												
100	161.5	8.3	161.5	3.3	161.5	4.3	161.5	3.9	196.5	4.6		
112	156.5	10.4	156.5	3.4	156.5	4.5	156.5	4.1	191.5	4.8		
132	186	15.7	186	5.1	186	6.2	186	5.8	241	6.5		
160	205.5	37.2	205.5	8	205.5	9.2	205.5	8.8	270.5	9.5		

Assignment												
Frame size	Fig. 8								Fig. 9			
	Brake, separately driven fan and rotary pulse encoder (under cover)								Protective cover for separately driven fan			
	Order codes F01 + F70 + G01/G02		Order codes F01 + F70 + G04		Order codes F01 + F70 + G05		Order codes F01 + F70 + G06		Order code H00			
	Δl	Weight approx.	Δl	Weight approx.	Δl	Weight approx.	Δl	Weight approx.	Δl	Weight approx.	Diameter of the fan cover	
	mm	kg	mm	kg	mm	kg	mm	kg	mm	kg	mm	
<b>1LE1</b>												
100	196.5	9.2	196.5	10.2	196.5	9.8	246.5	10.5	30	1.4	210	
112	191.5	11.2	191.5	12.3	191.5	11.9	241.5	12.6	33	1.8	249	
132	241	17	241	18.1	241	17.7	291	18.4	24	2.4	300	
160	270.5	38.7	270.5	39.9	270.5	39.5	320.5	40.2	31	3	338	

# IEC Squirrel-Cage Motors

## Introduction motors 1LE1/1PC1

### General technical data

0

Assignment						
Fig. 10			Fig. 11			
Frame size	Prepared for mountings – only center hole (for Brake order code <b>F01</b> and/or rotary pulse encoder order codes <b>G01/G02/G04/G05/G06</b> ) Order code <b>G40</b>		Prepared for mountings with shaft D12/D16 Order codes <b>G41/G42</b>			
	Order code <b>G40</b>		Order code <b>G41</b>		Order code <b>G42</b>	
	$\Delta l$	Weight approx.	$\Delta l$	Weight approx.	$\Delta l$	Weight approx.
	mm	kg	mm	kg	mm	kg
<b>1LE1</b>						
100	0	0	11.3	0.15	47.3	0.2
112	0	0	7.5	0.15	47.3	0.2
132	0	0.1	10.3	0.3	50.3	0.4
160	0	0.2	5.6	0.4	45.6	0.7

# New Generation 1LE1/1PC1



<b>1/2</b>	<b>Orientation</b>
1/2	Overview
1/3	Benefits
1/4	Application
1/4	Technical specifications
1/5	Selection and ordering data
1/7	More information
<b>1/8</b>	<b>General Line motors with shorter delivery time</b>
1/8	Selection and ordering data
<b>1/18</b>	<b>Self-ventilated energy-saving motors with improved efficiency</b>
1/18	Selection and ordering data
<b>1/22</b>	<b>Self-ventilated energy-saving motors with high efficiency</b>
1/22	Selection and ordering data
<b>1/30</b>	<b>Self-ventilated motors with increased output and improved efficiency</b>
1/30	Selection and ordering data
<b>1/34</b>	<b>Self-ventilated motors with increased output and high efficiency</b>
1/34	Selection and ordering data
<b>1/38</b>	<b>Forced-air cooled motors without external fan and fan cover with improved efficiency</b>
1/38	Selection and ordering data
<b>1/42</b>	<b>Forced-air cooled motors without external fan and fan cover with high efficiency</b>
1/42	Selection and ordering data
<b>1/46</b>	<b>Self-cooled motors without external fan and fan cover with improved efficiency</b>
1/46	Selection and ordering data
<b>1/50</b>	<b>Self-cooled motors without external fan and fan cover with high efficiency</b>
1/50	Selection and ordering data
<b>1/54</b>	<b>Special versions</b>
1/54	Selection and ordering data
1/54	• Voltages
1/55	• Options
<b>1/64</b>	<b>Accessories</b>
1/64	Overview
1/64	More information
<b>1/65</b>	<b>Dimensions</b>
1/65	Overview
1/67	More information
1/68	Dimensional drawings

# IEC Squirrel-Cage Motors

## New Generation 1LE1/1PC1

### Orientation

### Overview

1



Increasing energy costs have resulted in greater emphasis on the power consumption of drive systems. It is extremely important to utilize the full potential for minimization here to secure competitiveness today and in the future. The environment will also profit from reduced energy consumption.

With this in mind, we have already developed a new generation of low-voltage motors that you can use in drives to move even more than before. Innovative copper rotors that we develop and manufacture entirely in-house create the perfect conditions for motors with a high degree of efficiency (EFF2 and EFF1 motors are located in the same housing). The new motors for EFF1 (High Efficiency) offer considerable energy savings and protect our environment.

The modular mounting concept also provides total flexibility: Each motor is based on a uniform concept for all markets worldwide. Our motors are manufactured in accordance with modern ecological principles and give machines and plants more drive. Worldwide and for every application. Efficiency over the complete life cycle is a clear benefit of our motors especially for the use of 1LE1/1PC1 designed to EFF1. All machine manufacturers and plant operators can profit from this – not to mention the environment. We will be launching our new 1LE1/1PC1 motors onto the market step by step.

#### **Classified energy-saving motors for an efficient energy balance**

Depending on requirements, energy-saving motors are available for an efficient energy balance for the EU in accordance with CEMEP (European Committee of Manufacturers of Electrical Machines and Power Electronics) as well as for the North American market in accordance with EPACT (US Energy Policy Act).

#### Efficiency requirements according to CEMEP

CEMEP classifies efficiency levels for 2-pole and 4-pole motors with outputs of 1.1 to 90 kW. Three efficiency classes are defined:

- **EFF1** (High Efficiency motors – referred to below as “Motors with high efficiency”)
- **EFF2** (Improved Efficiency motors – referred to below as “Motors with improved efficiency”)
- **EFF3** (Conventional Efficiency motors)

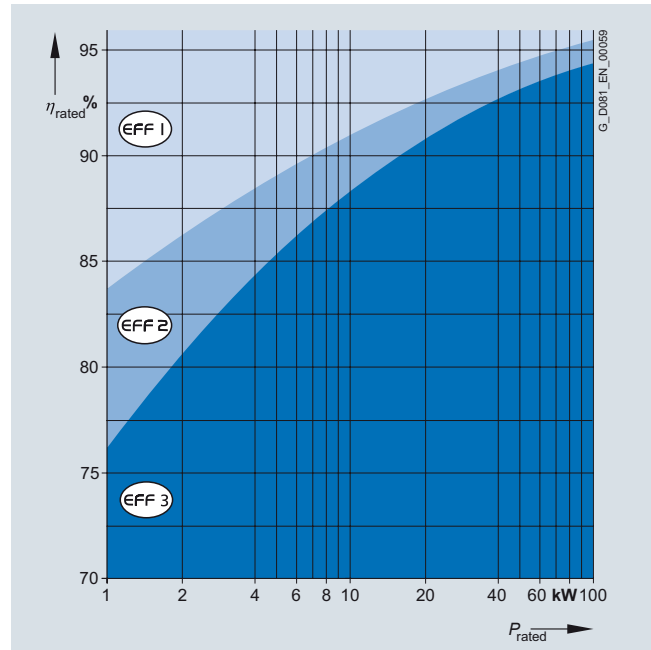

#### At a glance: EU/CEMEP for Europe

- Status  
Voluntary compliance with efficiency classification
- Covers  
2-pole, 4-pole 50 Hz squirrel-cage motors from 1.1 to 90 kW (at 400 V and 50 Hz)
- Required marking  
Efficiency class on the motor rating plate  
 $\eta_{rated}$ ,  $\eta_{3/4}$  load and efficiency class in the documentation

#### Efficiency requirements according to EPACT

In 1997, an act was passed in the US to define minimum efficiencies for low-voltage three-phase motors (EPACT).

An act is in force in Canada that is largely identical, although it is based on different verification methods. The efficiency is verified for these motors for the USA using IEEE 112, Test Method B and for Canada using CSA-C390. Apart from a few exceptions, all three-phase low-voltage motors imported into the USA or Canada must comply with the legal efficiency requirements. The law demands minimum efficiency levels for motors with a voltage of 230 and 460 V at 60 Hz, in the output range of 1 to 200 HP (0.75 to 150 kW) with 2, 4 and 6 poles. Explosion-proof motors must also be included.

The EPACT efficiency requirements exclude, for example:

- Motors whose frame size-output classification does not correspond with the standard series according to NEMA MG1-12.
- Flange-mounting motors
- Brake motors
- Converter-fed motors
- Motors with design letter C and higher



### Overview (continued)

EPACT lays down that the nominal efficiency at full load and a "CC" number (Compliance Certification) must be included on the rating plate. The "CC" number is issued by the US Department of Energy (DOE). The following information is stamped on the rating plate of EPACT motors which must be marked by law:

- Nominal efficiency
- Design letter
- Code letter
- CONT
- CC No. CC 032A (Siemens) and NEMA MG1-12.

#### At a glance: EPACT/CSA for North America

- Status  
Minimum efficiencies required by law
- Covers  
2-, 4- and 6-pole 60 Hz squirrel-cage motors from 1 to 200 HP (0.75 to 150 kW) for 230 V and/or 460 V 60 Hz
- Required marking  
Efficiency  $\eta_{\text{rated}}$  on the motor rating plate

#### Motors with increased output and compact construction (1LE1)

Motors with increased output and compact construction can be used to advantage in confined spaces. For a slightly longer overall length, the output is at least as high as that of the next larger shaft height. These compact motors are also optimized for efficiency. They are available in EFF1 and EFF2 and therefore reduce the operating costs.

### Benefits

There is considerable potential in our new 1LE1/1PC1 series of low-voltage motors. As a consistent further development of our existing motors, the 1LE1/1PC1 motors offer numerous advantages:

#### Greater efficiency

Instead of cast-aluminum rotors, the new copper technology is used in the EFF1 motors. The motors are therefore considerably more compact. EFF2 and EFF1 motors are based on the same housing. For changeover to the higher efficiency class – from EFF2 to EFF1 – reconstruction of the machine is no longer necessary. Savings are achieved in time and costs. And what is more: You can save a considerable amount of energy with EFF1 motors because they have power losses of up to 40 % less than EFF2 motors. The energy saving potential and life cycle costs of the new motors can be calculated with our SinaSave™ software. You can download the SinaSave program in the Internet using the following link: <http://www.siemens.com/energysaving>. For more information, see catalog part 11 "Appendix", "Energy-saving program SinaSave". Our 1LE1 motors also impress customers with their extremely long life and their weight-optimized design has a positive effect on the stability of the equipment unit.

#### Motors without fan cover and external fan (1LE1 with order code F90)

Forced-air cooled motors with surface cooling without fan cover and external fan are mainly used for driving fans.

#### Standard motors with reduced output without fan cover and external fan (1PC1)

Self-cooled motors with surface cooling without fan cover and external fan are suitable for the following operating conditions:

- Types of duty with adequate cooling times (e.g. temporary duty for positioning drives)
- Environmental conditions that demand compact installation space (e.g. in motors with a stopping function)

Conditions under which an external fan has an adverse effect (e.g. simple cleaning in the food industry, textile industry)

#### Motors delivered ex-stock with shorter delivery time – General Line 1LE1

The most popular basic versions of the 1LE1 motor series can be supplied ex-stock and are termed the "General Line".

A so-called "Sector version" will be available soon for some of the motors available from stock. These include a located bearing at the drive end (DE), PTC thermistor and screwed-on feet for the IM B35 type of construction.

The normal delivery time for General Line motors is 1 to 2 days from the time of clarification of the order at the factory until delivery from the factory. To determine the time of arrival at the customer site, the appropriate shipping time must be added.

#### More application

The motors are approved and certified for worldwide use and meet high quality standards (confirmed, for example, by CSA<sup>1)</sup>, UL<sup>2)</sup>, and CQC<sup>3)</sup>).

#### Improved design

The new, optimized housing in modern EMC design has an attractive appearance and enhances functionality. The rotatable, accessible connection boxes, integral eyebolts, screwed-on feet and reinforced bearing plates ensure this.

#### Greater output

For the same shaft height, our high-performance motors offer an additional complete rated output level. The best is: We are also consistently implementing energy efficiency improvements here, too. The motors are offered – based on the categories of CEMEP – in high efficiency and improved efficiency versions.

#### More flexibility

The optimized architecture of the motors makes installation easier in general. Encoders, brakes and separately driven fans can be retrofitted easily. Connection boxes and feet for flexible mounting can be selected. Smaller inventories make stockkeeping easier and motor suppliers can respond to customer requirements more quickly. Optimized manufacturing processes support fast availability. All motors up to 460 V can be operated either directly on line or converter-fed – without the need for any additional measures.

1) Canadian Standard Association

2) Underwriters Laboratories Inc.

3) China Quality Certification

# IEC Squirrel-Cage Motors

## New Generation 1LE1/1PC1

### Orientation

#### Application

As soon as the range of motors and options is complete, it will be possible to use the 1LE1/1PC1 motors from Siemens in all areas and sectors of industry due to their numerous options. They are suitable both for special environmental conditions such as those that predominate in the chemical or petrochemical industries as well as for most climatic requirements such as those of offshore applications. Their large range of mains voltages enables them to be used all over the world.

The wide field of implementation includes the following applications:

- Pumps
- Fans
- Compressors
- Conveyor systems such as cranes, belts and lifting gear
- High-bay warehouses
- Packaging machines
- Automation and Drives

#### Technical specifications

##### Technical data at a glance

This table lists the most important technical data. For more information and details, see catalog part 0 "Introduction".

Type of motor	IEC Squirrel-Cage Motors 1LE1/1PC1
Connection types	Star connection/delta connection You can establish the connection type used from the Order No. supplements in the selection and ordering data for the required motor.
Number of poles	2, 4, 6, 8
Frame sizes	100 L to 160 L
Rated output	0.75 ... 22 kW (motor series 1LE1)/0.3 ... 9 kW (motor series 1PC1)
Frequencies	50 Hz and 60 Hz
Versions	Self-ventilated 1LE1 energy-saving motors with: <ul style="list-style-type: none"> <li>• Improved efficiency (EFF2)</li> <li>• High efficiency (EFF1)</li> </ul> Self-ventilated 1LE1 motors with increased output and: <ul style="list-style-type: none"> <li>• Improved efficiency (EFF2)</li> <li>• High efficiency (EFF1)</li> </ul> Forced-air-cooled 1LE1 motors without external fan and fan cover with: <ul style="list-style-type: none"> <li>• Improved efficiency (EFF2)</li> <li>• High efficiency (EFF1)</li> </ul> Self-cooled 1PC1 motors without external fan and fan cover with: <ul style="list-style-type: none"> <li>• Improved efficiency</li> <li>• High efficiency</li> </ul>
Marking	EU/CEMPEP efficiency classification, EFF1: 2-, 4-pole, EFF2: 2-, 4-pole US Energy Policy Act EPACKT: 2-, 4-, 6-pole
Rated speed (synchronous speed)	750 ... 3000 rpm
Rated torque	9.9 ... 150 Nm (motor series 1LE1)/4.05 ... 60 Nm (motor series 1PC1)
Insulation of the stator winding according to EN 60034-1 (IEC 60034-1)	Temperature class 155 (F), used acc. to temperature class 130 (B) (also for motors with increased output) DURIGNIT IR 2000 insulation system
Degree of protection according to EN 60034-5 (IEC 60034-5)	IP55 as standard
Cooling according to EN 60034-6 (IEC 60034-6)	Self-ventilated (motor series 1LE1) frame sizes 100 L to 160 L (IC 411), Forced-air-cooled (motor series 1LE1 with order code F90) frame sizes 100 L to 160 L (IC 416) Self-cooled (motor series 1PC1) frame sizes 100 L to 160 L (IC 410)
Admissible coolant temperature and site altitude	-20 °C ... +40 °C as standard, site altitude up to 1000 m above sea level. See "Coolant temperature and site altitude" in catalog part 0 "Introduction".
Standard voltages according to EN 60038 (IEC 60038)	50 Hz: 230 V, 400 V, 500 V, 690 V The voltage to be used can be found in the selection and ordering data for the required motor.
Type of construction according to EN 60034-7 (IEC 60034-7)	Without flange: IM B3, IM B6, IM B7, IM B8, IM V5 without protective cover, IM V6, IM V5 with protective cover With flange: IM B5, IM V1 without protective cover, IM V1 with protective cover, IM V3, IM B35 With standard flange and special flange (next larger flange): IM B14, IM V19, IM V18 without protective cover, IM V18 with protective cover, IM B34
Paint finish Suitability of paint finish for climate group according to IEC 60721, Part 2-1	Standard: Color RAL 7030 stone gray See "Paint finish" in catalog part 0 "Introduction".
Vibration quantity level according to EN 60034-14 (IEC 60034-14)	Level A (normal – without special vibration requirements) Optionally: Level B (with special vibration requirements) See "Balance and vibration quantity" in catalog part 0 "Introduction".
Shaft extension according to DIN 748 (IEC 60072)	Balance type: Half-key balancing as standard See "Balance and vibration quantity" in catalog part 0 "Introduction".
Sound pressure level according to DIN EN ISO 1680 (tolerance +3 dB)	The sound pressure level is listed in the selection and ordering data for the required motor.
Weights	The weight is listed in the selection and ordering data for the required motor.
Modular mounting concept	Rotary pulse encoder, brake, separately driven fan or prepared for mountings
Consistent series concept	<ul style="list-style-type: none"> <li>• Cast housing feet, screw-mounted feet available as an option and retrofittable</li> <li>• Connection box obliquely partitioned and rotatable through 4 x 90°</li> <li>• Bearings at DE and NDE are of identical design, reinforced bearings available as an option</li> </ul>
Options	See the selection and ordering data for "Special versions"

### Selection and ordering data

*Preliminary selection of the motor according to motor type/series, speed or number of poles, frame size, rated output, rated torque, rated speed and rated current*

General Line motors with shorter delivery time

Speed	Frame size	Rated output	Rated speed	Rated torque	Rated current at 400 V	Detailed selection and ordering data Page
rpm		kW	rpm	Nm	A	
<b>Aluminum series 1LE1 (motors with external fan)</b>						
<b>3000, 2-pole</b>	<b>100 L ... 160 L</b>	3 ... 18.5	2835 ... 2935	10 ... 60	6 ... 34	<b>1/8 ... 1/11</b>
<b>1500, 4-pole</b>	<b>100 L ... 160 L</b>	2.2 ... 15	1425 ... 1460	14.8 ... 98	4.85 ... 29.5	<b>1/12 ... 1/15</b>
<b>1000, 6-pole</b>	<b>100 L ... 160 L</b>	1.5 ... 11	930 ... 970	15.3 ... 110	3.95 ... 23.5	<b>1/16 ... 1/17</b>

Self-ventilated energy-saving motors with improved efficiency (Improved Efficiency EFF2)

Speed	Frame size	Rated output	Rated speed	Rated torque	Rated current at 400 V	Detailed selection and ordering data Page
rpm		kW	rpm	Nm	A	
<b>Aluminum series 1LE1 (motors with external fan)</b>						
<b>3000, 2-pole</b>	<b>100 L ... 160 L</b>	3 ... 18.5	2835 ... 2935	10 ... 60	6 ... 34	<b>1/18 ... 1/19</b>
<b>1500, 4-pole</b>	<b>100 L ... 160 L</b>	2.2 ... 15	1425 ... 1460	14.8 ... 98	4.85 ... 29.5	<b>1/18 ... 1/19</b>
<b>1000, 6-pole</b>	<b>100 L ... 160 L</b>	1.5 ... 11	930 ... 970	15.3 ... 110	3.95 ... 23.5	<b>1/18 ... 1/19</b>
<b>750, 8-pole</b>	<b>100 L ... 160 L</b>	0.75 ... 7.5	700 ... 720	10.4 ... 100	2.65 ... 18.6	<b>1/18 ... 1/19</b>

Self-ventilated energy-saving motors with high efficiency (High Efficiency EFF1)

Speed	Frame size	Rated output	Rated speed	Rated torque	Rated current at 400 V	Detailed selection and ordering data Page
rpm		kW/HP	rpm	Nm	A	
<b>Aluminum series 1LE1 (motors with external fan)</b>						
<b>For use according to CEMEP</b>						
<b>3000, 2-pole</b>	<b>100 L ... 160 L</b>	3 ... 18.5	2905 ... 2955	9.9 ... 60	5.9 ... 33	<b>1/22 ... 1/23</b>
<b>1500, 4-pole</b>	<b>100 L ... 160 L</b>	2.2 ... 15	1455 ... 1475	14 ... 97	4.55 ... 27.5	<b>1/22 ... 1/23</b>
<b>1000, 6-pole</b>	<b>100 L ... 160 L</b>	1.5 ... 11	965 ... 975	15 ... 108	3.5 ... 22	<b>1/22 ... 1/23</b>
<b>750, 8-pole</b>	<b>100 L ... 160 L</b>	0.75 ... 7.5	720 ... 735	9.9 ... 98	2.75 ... 17.4	<b>1/22 ... 1/23</b>
<b>For use in the North American market according to EPACT</b>						
<b>3000, 2-pole</b>	<b>100 L ... 160 L</b>	4 ... 25	3520 ... 3565	8.1 ... 50	5.2 ... 29	<b>1/26 ... 1/27</b>
<b>1500, 4-pole</b>	<b>100 L ... 160 L</b>	3 ... 20	1760 ... 1780	12 ... 80	4.05 ... 24.5	<b>1/26 ... 1/27</b>
<b>1000, 6-pole</b>	<b>100 L ... 160 L</b>	2 ... 15	1170 ... 1180	12 ... 89	3.15 ... 19.6	<b>1/26 ... 1/27</b>

Self-ventilated motors with increased output and improved efficiency (Improved Efficiency EFF2)

Speed	Frame size	Rated output	Rated speed	Rated torque	Rated current at 400 V	Detailed selection and ordering data Page
rpm		kW	rpm	Nm	A	
<b>Aluminum series 1LE1 (motors with external fan)</b>						
<b>3000, 2-pole</b>	<b>100 L ... 160 L</b>	4 ... 22	2850 ... 2930	13.3 ... 72	7.9 ... 39.5	<b>1/30 ... 1/31</b>
<b>1500, 4-pole</b>	<b>100 L ... 160 L</b>	4 ... 18.5	1430 ... 1460	26.8 ... 121	8.5 ... 35	<b>1/30 ... 1/31</b>
<b>1000, 6-pole</b>	<b>100 L ... 160 L</b>	2.2 ... 15	930 ... 965	22.5 ... 148	5.3 ... 33	<b>1/30 ... 1/31</b>

Self-ventilated motors with increased output and high efficiency (High Efficiency EFF1)

Speed	Frame size	Rated output	Rated speed	Rated torque	Rated current at 400 V	Detailed selection and ordering data Page
rpm		kW	rpm	Nm	A	
<b>Aluminum series 1LE1 (motors with external fan)</b>						
<b>3000, 2-pole</b>	<b>100 L ... 160 L</b>	4 ... 22	2905 ... 2955	13 ... 71	7.6 ... 38.5	<b>1/34 ... 1/35</b>
<b>1500, 4-pole</b>	<b>100 L ... 160 L</b>	4 ... 18.5	1460 ... 1475	26 ... 120	8.2 ... 34	<b>1/34 ... 1/35</b>
<b>1000, 6-pole</b>	<b>100 L ... 160 L</b>	2.2 ... 15	960 ... 975	22 ... 147	4.95 ... 29.5	<b>1/34 ... 1/35</b>

# IEC Squirrel-Cage Motors

## New Generation 1LE1/1PC1

### Orientation

#### Selection and ordering data (continued)

##### Forced-air cooled motors without external fan and fan cover with improved efficiency (Improved Efficiency EFF2)

Speed	Frame size	Rated output	Rated speed	Rated torque	Rated current at 400 V	Detailed selection and ordering data Page
rpm		kW	rpm	Nm	A	
<b>Aluminum series 1LE1 (motors without external fan and fan cover)</b>						
<b>3000, 2-pole</b>	<b>100 L ... 160 L</b>	3 ... 18.5	2835 ... 2935	10 ... 60	6 ... 34	<b>1/38 ... 1/39</b>
<b>1500, 4-pole</b>	<b>100 L ... 160 L</b>	2.2 ... 15	1425 ... 1460	14.8 ... 98	4.85 ... 29.5	<b>1/38 ... 1/39</b>
<b>1000, 6-pole</b>	<b>100 L ... 160 L</b>	1.5 ... 11	930 ... 970	15.3 ... 110	3.95 ... 23.5	<b>1/38 ... 1/39</b>
<b>750, 8-pole</b>	<b>100 L ... 160 L</b>	0.75 ... 7.5	700 ... 720	10.4 ... 100	2.65 ... 18.6	<b>1/38 ... 1/39</b>

##### Forced-air cooled motors without external fan and fan cover with high efficiency (High Efficiency EFF1)

Speed	Frame size	Rated output	Rated speed	Rated torque	Rated current at 400 V	Detailed selection and ordering data Page
rpm		kW	rpm	Nm	A	
<b>Aluminum series 1LE1 (motors without external fan and fan cover)</b>						
<b>3000, 2-pole</b>	<b>100 L ... 160 L</b>	3 ... 18.5	2905 ... 2955	9.9 ... 60	5.9 ... 33	<b>1/42 ... 1/43</b>
<b>1500, 4-pole</b>	<b>100 L ... 160 L</b>	2.2 ... 15	1455 ... 1475	14 ... 97	4.55 ... 27.5	<b>1/42 ... 1/43</b>
<b>1000, 6-pole</b>	<b>100 L ... 160 L</b>	1.5 ... 11	965 ... 975	15 ... 108	3.5 ... 22	<b>1/42 ... 1/43</b>
<b>750, 8-pole</b>	<b>100 L ... 160 L</b>	0.75 ... 7.5	720 ... 735	9.9 ... 98	2.75 ... 17.4	<b>1/42 ... 1/43</b>

##### Self-cooled motors without external fan and fan cover with improved efficiency

Speed	Frame size	Rated output	Rated speed	Rated torque	Rated current at 400 V	Detailed selection and ordering data Page
rpm		kW	rpm	Nm	A	
<b>Aluminum series 1PC1 (motors without external fan and fan cover)</b>						
<b>3000, 2-pole</b>	<b>100 L ... 160 L</b>	1.2 ... 7.4	2830 ... 2935	4.05 ... 24	2.3 ... 12.9	<b>1/46 ... 1/47</b>
<b>1500, 4-pole</b>	<b>100 L ... 160 L</b>	0.88 ... 6	1420 ... 1460	5.92 ... 39	1.8 ... 10.9	<b>1/46 ... 1/47</b>
<b>1000, 6-pole</b>	<b>100 L ... 160 L</b>	0.6 ... 4.4	930 ... 970	6.12 ... 43	1.4 ... 8.9	<b>1/46 ... 1/47</b>
<b>750, 8-pole</b>	<b>100 L ... 160 L</b>	0.3 ... 3	695 ... 730	4.05 ... 24	0.97 ... 6.8	<b>1/46 ... 1/47</b>

##### Self-cooled motors without external fan and fan cover with high efficiency

Speed	Frame size	Rated output	Rated speed	Rated torque	Rated current at 400 V	Detailed selection and ordering data Page
rpm		kW	rpm	Nm	A	
<b>Aluminum series 1PC1 (motors without external fan and fan cover)</b>						
<b>3000, 2-pole</b>	<b>100 L ... 160 L</b>	1.4 ... 9	2920 ... 2960	4.6 ... 29	2.6 ... 15.2	<b>1/50 ... 1/51</b>
<b>1500, 4-pole</b>	<b>100 L ... 160 L</b>	1.1 ... 6.2	1460 ... 1480	7.2 ... 40	2.2 ... 11.4	<b>1/50 ... 1/51</b>
<b>1000, 6-pole</b>	<b>100 L ... 160 L</b>	0.85 ... 6.5	960 ... 975	8.5 ... 64	1.92 ... 13.2	<b>1/50 ... 1/51</b>
<b>750, 8-pole</b>	<b>100 L ... 160 L</b>	0.37 ... 4.6	720 ... 730	4.8 ... 60	1.28 ... 10.8	<b>1/50 ... 1/51</b>

### More information

For further information, please get in touch with your local Siemens contact.

At <http://www.siemens.com/automation/partner> you can find details of Siemens contact partners worldwide responsible for particular technologies.

You can obtain in most cases a contact partner for

- technical support
- spare parts/repairs
- service
- training
- sales or
- technical support/engineering

The selection procedure starts with:

- a country
- a product or
- a sector.

By further specifying the remaining criteria you will find exactly the right contact partner with his/her respective expertise.

# IEC Squirrel-Cage Motors

## New Generation 1LE1/1PC1

General Line motors with shorter delivery time

### Selection and ordering data

Rated output at		Frame size	Operating values at rated output							Order No.	Price	Weight
50 Hz	60 Hz		Rated speed at 50 Hz	Rated torque at 50 Hz	Efficiency Class according to CEMEP	Efficiency at 50 Hz 4/4-load	Efficiency at 50 Hz 3/4-load	Power factor at 50 Hz 4/4-load	Rated current at 400 V, 50 Hz			
$P_{\text{rated}}$ kW	$P_{\text{rated}}$ kW	FS	$n_{\text{rated}}$ rpm	$T_{\text{rated}}$ Nm	EFF2	$\eta_{\text{rated}}$ %	$\eta_{\text{rated}}$ %	$\cos\phi_{\text{rated}}$	$I_{\text{rated}}$ A		$m$ kg	
<b>Motor version: temperature class 155 (F), IP55 degree of protection, used acc. to temperature class 130 (B)</b>												
<b>2-pole – 3000 rpm at 50 Hz, 3600 rpm at 60 Hz</b>												
<b>230 VΔ/400 VY, 50 Hz; 460 VY, 60 Hz</b>												
• Without flange: IM B3, IM B6, IM B7, IM B8, IM V5 without protective cover, IM V6 <sup>1)</sup>												
- Without motor protection												
3	3.45	100 L	2835	10	EFF2	82.6	83.2	0.87	6	<b>1LE1002-1AA42-2AA0</b>	20	
4	4.6	112 M	2930	13	EFF2	84.8	84.4	0.86	7.9	<b>1LE1002-1BA22-2AA0</b>	25	
5.5	6.3	132 S	2905	18	EFF2	86	86.6	0.89	10.4	<b>1LE1002-1CA02-2AA0</b>	35	
7.5	8.6	132 S	2925	24	EFF2	87.6	88.7	0.88	14	<b>1LE1002-1CA12-2AA0</b>	40	
• With flange: IM B5, IM V1 without protective cover, IM V3 <sup>2)</sup>												
- Without motor protection												
3	3.45	100 L	2835	10	EFF2	82.6	83.2	0.87	6	<b>1LE1002-1AA42-2FA0</b>	21	
4	4.6	112 M	2930	13	EFF2	84.8	84.4	0.86	7.9	<b>1LE1002-1BA22-2FA0</b>	26	
5.5	6.3	132 S	2905	18	EFF2	86	86.6	0.89	10.4	<b>1LE1002-1CA02-2FA0</b>	40	
7.5	8.6	132 S	2925	24	EFF2	87.6	88.7	0.88	14	<b>1LE1002-1CA12-2FA0</b>	45	
- With motor protection with PTC thermistors with 3 embedded temperature sensors for tripping												
3	3.45	100 L	2835	10	EFF2	82.6	83.2	0.87	6	<b>1LE1002-1AA42-2FB0</b>	21	
• With standard flange: IM B14, IM V18 without protective cover, IM V19 <sup>3)</sup>												
- Without motor protection												
3	3.45	100 L	2835	10	EFF2	82.6	83.3	0.87	6	<b>1LE1002-1AA42-2KA0</b>	22	
4	4.6	112 M	2930	13	EFF2	84.8	84.4	0.86	7.9	<b>1LE1002-1BA22-2KA0</b>	27	

These motors are standard painted with special finish color RAL 7030 (stone gray).

Additional options like protective cover and condensation drainage holes are not possible.

(Connection box on top, cast feet, only basic versions possible, non-drive end (NDE) cannot be modified)

<sup>1)</sup> Only the type of construction IM B3 will be stamped on the rating plate.

<sup>2)</sup> Only the type of construction IM B5 will be stamped on the rating plate.

<sup>3)</sup> Only the type of construction IM B14 will be stamped on the rating plate.

# IEC Squirrel-Cage Motors

## New Generation 1LE1/1PC1

General Line motors with shorter delivery time

### Selection and ordering data (continued)

Order No.	Locked-rotor torque	Locked-rotor current	Breakdown torque	Torque class	Moment of inertia	Noise at rated output		Flange size according to DIN EN 50347
	with direct starting as multiple of rated torque	as multiple of rated current	torque			Measuring-surface sound pressure level at 50 Hz	Sound pressure level at 50 Hz	
	$T_{LR}/T_{rated}$	$I_{LR}/I_{rated}$	$T_B/T_{rated}$	CL	$J$ kgm <sup>2</sup>	$L_{pFA}$ dB(A)	$L_{WA}$ dB(A)	
<b>Motor version: temperature class 155 (F), IP55 degree of protection, used acc. to temperature class 130 (B)</b>								
<b>2-pole – 3000 rpm at 50 Hz, 3600 rpm at 60 Hz</b>								
<b>230 VΔ/400 VY, 50 Hz; 460 VY, 60 Hz</b>								
• Without flange: IM B3, IM B6, IM B7, IM B8, IM V5 without protective cover, IM V6 <sup>1)</sup>								
- Without motor protection								
<b>1LE1002-1AA42-2AA0</b>	3.2	6.2	2.9	16	0.0034	67	79	
<b>1LE1002-1BA22-2AA0</b>	2.7	7.3	3.7	16	0.0067	69	81	
<b>1LE1002-1CA02-2AA0</b>	2	5.6	2.6	16	0.01267	68	80	
<b>1LE1002-1CA12-2AA0</b>	2.2	6.4	3	16	0.01601	68	80	
• With flange: IM B5, IM V1 without protective cover, IM V3 <sup>2)</sup>								
- Without motor protection								
<b>1LE1002-1AA42-2FA0</b>	3.2	6.2	2.9	16	0.0034	67	79	FF 215
<b>1LE1002-1BA22-2FA0</b>	2.7	7.3	3.7	16	0.0067	69	81	FF 215
<b>1LE1002-1CA02-2FA0</b>	2	5.6	2.6	16	0.01267	68	80	FF 265
<b>1LE1002-1CA12-2FA0</b>	2.2	6.4	3	16	0.01601	68	80	FF 265
- With motor protection with PTC thermistors with 3 embedded temperature sensors for tripping								
<b>1LE1002-1AA42-2FB0</b>	3.2	6.2	2.9	16	0.0034	67	79	FF 215
• With standard flange: IM B14, IM V18 without protective cover, IM V19 <sup>3)</sup>								
- Without motor protection								
<b>1LE1002-1AA42-2KA0</b>	3.2	6.2	2.9	16	0.0034	67	79	FT 130
<b>1LE1002-1BA22-2KA0</b>	2.7	7.3	3.7	16	0.0067	69	81	FT 130

These motors are standard painted with special finish color RAL 7030 (stone gray).

Additional options like protective cover and condensation drainage holes are not possible.

(Connection box on top, cast feet, only basic versions possible, non-drive end (NDE) cannot be modified)

1) Only the type of construction IM B3 will be stamped on the rating plate.  
 2) Only the type of construction IM B5 will be stamped on the rating plate.  
 3) Only the type of construction IM B14 will be stamped on the rating plate.

# IEC Squirrel-Cage Motors

## New Generation 1LE1/1PC1

General Line motors with shorter delivery time

### Selection and ordering data (continued)

Rated output at		Frame size	Operating values at rated output							Order No.	Price	Weight
50 Hz	60 Hz		Rated speed at 50 Hz	Rated torque at 50 Hz	Efficiency Class according to CEMEP	Efficiency at 50 Hz 4/4-load	Efficiency at 50 Hz 3/4-load	Power factor at 50 Hz 4/4-load	Rated current at 400 V, 50 Hz			
$P_{rated}$ kW	$P_{rated}$ kW	FS	$n_{rated}$ rpm	$T_{rated}$ Nm		$\eta_{rated}$ %	$\eta_{rated}$ %	$\cos\phi_{rated}$	$I_{rated}$ A		$m$ kg	
<b>Motor version: temperature class 155 (F), IP55 degree of protection, used acc. to temperature class 130 (B)</b>												
<b>2-pole – 3000 rpm at 50 Hz, 3600 rpm at 60 Hz</b>												
<b>400 V<math>\Delta</math>/690 VY, 50 Hz; 460 V<math>\Delta</math>, 60 Hz</b>												
• Without flange: IM B3, IM B6, IM B7, IM B8, IM V5 without protective cover, IM V6 <sup>1)</sup>												
- Without motor protection												
3	3.45	100 L	2835	10	EFF2	82.6	83.2	0.87	6	<b>1LE1002-1AA43-4AA0</b>	20	
4	4.6	112 M	2930	13	EFF2	84.8	84.4	0.86	7.9	<b>1LE1002-1BA23-4AA0</b>	25	
5.5	6.3	132 S	2905	18	EFF2	86	86.6	0.89	10.4	<b>1LE1002-1CA03-4AA0</b>	35	
7.5	8.6	132 S	2925	24	EFF2	87.6	88.7	0.88	14	<b>1LE1002-1CA13-4AA0</b>	40	
11	12.6	160 M	2920	36	EFF2	88.4	88.5	0.85	21	<b>1LE1002-1DA23-4AA0</b>	60	
15	17.3	160 M	2930	49	EFF2	89.5	89.7	0.84	29	<b>1LE1002-1DA33-4AA0</b>	68	
18.5	21.3	160 L	2935	60	EFF2	90.9	91	0.86	34	<b>1LE1002-1DA43-4AA0</b>	78	
- With motor protection with PTC thermistors with 3 embedded temperature sensors for tripping												
3	3.45	100 L	2835	10	EFF2	82.6	83.2	0.87	6	<b>1LE1002-1AA43-4AB0</b>	20	
4	4.6	112 M	2930	13	EFF2	84.8	84.4	0.86	7.9	<b>1LE1002-1BA23-4AB0</b>	25	
5.5	6.3	132 S	2905	18	EFF2	86	86.6	0.89	10.4	<b>1LE1002-1CA03-4AB0</b>	35	
7.5	8.6	132 S	2925	24	EFF2	87.6	88.7	0.88	14	<b>1LE1002-1CA13-4AB0</b>	40	
11	12.6	160 M	2920	36	EFF2	88.4	88.5	0.85	21	<b>1LE1002-1DA23-4AB0</b>	60	
15	17.3	160 M	2930	49	EFF2	89.5	89.7	0.84	29	<b>1LE1002-1DA33-4AB0</b>	68	
18.5	21.3	160 L	2935	60	EFF2	90.9	91	0.86	34	<b>1LE1002-1DA43-4AB0</b>	78	
• With flange: IM B5, IM V1 without protective cover, IM V3 <sup>2)</sup>												
- Without motor protection												
3	3.45	100 L	2835	10	EFF2	82.6	83.2	0.87	6	<b>1LE1002-1AA43-4FA0</b>	21	
4	4.6	112 M	2930	13	EFF2	84.8	84.4	0.86	7.9	<b>1LE1002-1BA23-4FA0</b>	26	
5.5	6.3	132 S	2905	18	EFF2	86	86.6	0.89	10.4	<b>1LE1002-1CA03-4FA0</b>	40	
7.5	8.6	132 S	2925	24	EFF2	87.6	88.7	0.88	14	<b>1LE1002-1CA13-4FA0</b>	45	
11	12.6	160 M	2920	36	EFF2	88.4	88.5	0.85	21	<b>1LE1002-1DA23-4FA0</b>	69	
15	17.3	160 M	2930	49	EFF2	89.5	89.7	0.84	29	<b>1LE1002-1DA33-4FA0</b>	77	
18.5	21.3	160 L	2935	60	EFF2	90.9	91	0.86	34	<b>1LE1002-1DA43-4FA0</b>	87	
- With motor protection with PTC thermistors with 3 embedded temperature sensors for tripping												
4	4.6	112 M	2930	13	EFF2	84.8	84.4	0.86	7.9	<b>1LE1002-1BA23-4FB0</b>	26	
5.5	6.3	132 S	2905	18	EFF2	86	86.6	0.89	10.4	<b>1LE1002-1CA03-4FB0</b>	40	
7.5	8.6	132 S	2925	24	EFF2	87.6	88.7	0.88	14	<b>1LE1002-1CA13-4FB0</b>	45	
11	12.6	160 M	2920	36	EFF2	88.4	88.5	0.85	21	<b>1LE1002-1DA23-4FB0</b>	69	
15	17.3	160 M	2930	49	EFF2	89.5	89.7	0.84	29	<b>1LE1002-1DA33-4FB0</b>	77	
18.5	21.3	160 L	2935	60	EFF2	90.9	91	0.86	34	<b>1LE1002-1DA43-4FB0</b>	87	

These motors are standard painted with special finish color RAL 7030 (stone gray).

Additional options like protective cover and condensation drainage holes are not possible.

(Connection box on top, cast feet, only basic versions possible, non-drive end (NDE) cannot be modified)

<sup>1)</sup> Only the type of construction IM B3 will be stamped on the rating plate.

<sup>2)</sup> Only the type of construction IM B5 will be stamped on the rating plate.



# IEC Squirrel-Cage Motors

## New Generation 1LE1/1PC1

General Line motors with shorter delivery time

### Selection and ordering data (continued)

Order No.	Locked-rotor torque	Locked-rotor current	Breakdown torque	Torque class	Moment of inertia	Noise at rated output		Flange size according to DIN EN 50347
	with direct starting as multiple of rated torque	as multiple of rated current	torque			Measuring-surface sound pressure level at 50 Hz	Sound pressure level at 50 Hz	
	$T_{LR}/T_{rated}$	$I_{LR}/I_{rated}$	$T_B/T_{rated}$	CL	$J$ kgm <sup>2</sup>	$L_{pFA}$ dB(A)	$L_{WA}$ dB(A)	
<b>Motor version: temperature class 155 (F), IP55 degree of protection, used acc. to temperature class 130 (B)</b>								
<b>2-pole – 3000 rpm at 50 Hz, 3600 rpm at 60 Hz</b>								
<b>400 VΔ/690 VY, 50 Hz; 460 VΔ, 60 Hz</b>								
• Without flange: IM B3, IM B6, IM B7, IM B8, IM V5 without protective cover, IM V6 <sup>1)</sup>								
- Without motor protection								
<b>1LE1002-1AA43-4AA0</b>	3.2	6.2	2.9	16	0.0034	67	79	
<b>1LE1002-1BA23-4AA0</b>	2.7	7.3	3.7	16	0.0067	69	81	
<b>1LE1002-1CA03-4AA0</b>	2	5.6	2.6	16	0.01267	68	80	
<b>1LE1002-1CA13-4AA0</b>	2.2	6.4	3	16	0.01601	68	80	
<b>1LE1002-1DA23-4AA0</b>	2.1	6.1	2.7	16	0.02971	70	82	
<b>1LE1002-1DA33-4AA0</b>	2.5	6.1	3.2	16	0.03619	70	82	
<b>1LE1002-1DA43-4AA0</b>	2.5	7	3.2	16	0.04395	70	82	
- With motor protection with PTC thermistors with 3 embedded temperature sensors for tripping								
<b>1LE1002-1AA43-4AB0</b>	3.2	6.2	2.9	16	0.0034	67	79	
<b>1LE1002-1BA23-4AB0</b>	2.7	7.3	3.7	16	0.0067	69	81	
<b>1LE1002-1CA03-4AB0</b>	2	5.6	2.6	16	0.01267	68	80	
<b>1LE1002-1CA13-4AB0</b>	2.2	6.4	3	16	0.01601	68	80	
<b>1LE1002-1DA23-4AB0</b>	2.1	6.1	2.7	16	0.02971	70	82	
<b>1LE1002-1DA33-4AB0</b>	2.5	6.1	3.2	16	0.03619	70	82	
<b>1LE1002-1DA43-4AB0</b>	2.5	7	3.2	16	0.04395	70	82	
• With flange: IM B5, IM V1 without protective cover, IM V3 <sup>2)</sup>								
- Without motor protection								
<b>1LE1002-1AA43-4FA0</b>	3.2	6.2	2.9	16	0.0034	67	79	FF 215
<b>1LE1002-1BA23-4FA0</b>	2.7	7.3	3.7	16	0.0067	69	81	FF 215
<b>1LE1002-1CA03-4FA0</b>	2	5.6	2.6	16	0.01267	68	80	FF 265
<b>1LE1002-1CA13-4FA0</b>	2.2	6.4	3	16	0.01601	68	80	FF 265
<b>1LE1002-1DA23-4FA0</b>	2.1	6.1	2.7	16	0.02971	70	82	FF 300
<b>1LE1002-1DA33-4FA0</b>	2.5	6.1	3.2	16	0.03619	70	82	FF 300
<b>1LE1002-1DA43-4FA0</b>	2.5	7	3.2	16	0.04395	70	82	FF 300
- With motor protection with PTC thermistors with 3 embedded temperature sensors for tripping								
<b>1LE1002-1BA23-4FB0</b>	2.7	7.3	3.7	16	0.0067	69	81	FF 215
<b>1LE1002-1CA03-4FB0</b>	2	5.6	2.6	16	0.01267	68	80	FF 265
<b>1LE1002-1CA13-4FB0</b>	2.2	6.4	3	16	0.01601	68	80	FF 265
<b>1LE1002-1DA23-4FB0</b>	2.1	6.1	2.7	16	0.02971	70	82	FF 300
<b>1LE1002-1DA33-4FB0</b>	2.5	6.1	3.2	16	0.03619	70	82	FF 300
<b>1LE1002-1DA43-4FB0</b>	2.5	7	3.2	16	0.04395	70	82	FF 300

These motors are standard painted with special finish color RAL 7030 (stone gray).

Additional options like protective cover and condensation drainage holes are not possible.

(Connection box on top, cast feet, only basic versions possible, non-drive end (NDE) cannot be modified)

<sup>1)</sup> Only the type of construction IM B3 will be stamped on the rating plate.

<sup>2)</sup> Only the type of construction IM B5 will be stamped on the rating plate.

# IEC Squirrel-Cage Motors

## New Generation 1LE1/1PC1

General Line motors with shorter delivery time

### Selection and ordering data (continued)

Rated output at		Frame size	Operating values at rated output							Order No.	Price	Weight
50 Hz	60 Hz		Rated speed at 50 Hz	Rated torque at 50 Hz	Efficiency Class according to CEMEP	Efficiency at 50 Hz 4/4-load	Efficiency at 50 Hz 3/4-load	Power factor at 50 Hz 4/4-load	Rated current at 400 V, 50 Hz			
$P_{\text{rated}}$ kW	$P_{\text{rated}}$ kW	FS	$n_{\text{rated}}$ rpm	$T_{\text{rated}}$ Nm	EFF2	$\eta_{\text{rated}}$ %	$\eta_{\text{rated}}$ %	$\cos\phi_{\text{rated}}$	$I_{\text{rated}}$ A		$m$ kg	
<b>Motor version: temperature class 155 (F), IP55 degree of protection, used acc. to temperature class 130 (B)</b>												
<b>4-pole – 1500 rpm at 50 Hz, 1800 rpm at 60 Hz</b>												
<b>230 VΔ/400 VY, 50 Hz; 460 VY, 60 Hz</b>												
• Without flange: IM B3, IM B6, IM B7, IM B8, IM V5 without protective cover, IM V6 <sup>1)</sup>												
- Without motor protection												
2.2	2.55	100 L	1425	14.8	EFF2	81	84	0.81	4.85	1LE1002-1AB42-2AA0	18	
3	3.45	100 L	1425	20.2	EFF2	82.8	83.6	0.85	6.2	1LE1002-1AB52-2AA0	22	
4	4.6	112 M	1435	27	EFF2	84.2	85.1	0.84	8.2	1LE1002-1BB22-2AA0	27	
5.5	6.3	132 S	1450	36	EFF2	86	86.5	0.83	11.2	1LE1002-1CB02-2AA0	38	
7.5	8.6	132 M	1450	49	EFF2	87	87.4	0.83	15	1LE1002-1CB22-2AA0	44	
11	12.6	160 M	1460	72	EFF2	88.4	88.1	0.82	22	1LE1002-1DB22-2AA0	62	
15	17.3	160 L	1460	98	EFF2	89.4	89.7	0.82	29.5	1LE1002-1DB42-2AA0	73	
- With motor protection with PTC thermistors with 3 embedded temperature sensors for tripping												
2.2	2.55	100 L	1425	14.8	EFF2	81	84	0.81	4.85	1LE1002-1AB42-2AB0	18	
• With flange: IM B5, IM V1 without protective cover, IM V3 <sup>2)</sup>												
- Without motor protection												
2.2	2.55	100 L	1425	14.8	EFF2	81	84	0.81	4.85	1LE1002-1AB42-2FA0	19	
3	3.45	100 L	1425	20.2	EFF2	82.8	83.6	0.85	6.2	1LE1002-1AB52-2FA0	23	
4	4.6	112 M	1435	27	EFF2	84.2	85.1	0.84	8.2	1LE1002-1BB22-2FA0	28	
5.5	6.3	132 S	1450	36	EFF2	86	86.5	0.83	11.2	1LE1002-1CB02-2FA0	43	
7.5	8.6	132 M	1450	49	EFF2	87	87.4	0.83	15	1LE1002-1CB22-2FA0	49	
11	12.6	160 M	1460	72	EFF2	88.4	88.1	0.82	22	1LE1002-1DB22-2FA0	71	
15	17.3	160 L	1460	98	EFF2	89.4	89.7	0.82	29.5	1LE1002-1DB42-2FA0	82	
- With motor protection with PTC thermistors with 3 embedded temperature sensors for tripping												
2.2	2.55	100 L	1425	14.8	EFF2	81	84	0.81	4.85	1LE1002-1AB42-2FB0	19	
3	3.45	100 L	1425	20.2	EFF2	82.8	83.6	0.85	6.2	1LE1002-1AB52-2FB0	23	
4	4.6	112 M	1435	27	EFF2	84.2	85.1	0.84	8.2	1LE1002-1BB22-2FB0	28	
• With standard flange: IM B14, IM V18 without protective cover, IM V19 <sup>3)</sup>												
- Without motor protection												
2.2	2.55	100 L	1425	14.8	EFF2	81	84	0.81	4.85	1LE1002-1AB42-2KA0	20	
3	3.45	100 L	1425	20.2	EFF2	82.8	83.6	0.85	6.2	1LE1002-1AB52-2KA0	24	
4	4.6	112 M	1435	27	EFF2	84.2	85.1	0.84	8.2	1LE1002-1BB22-2KA0	29	

These motors are standard painted with special finish color RAL 7030 (stone gray).

Additional options like protective cover and condensation drainage holes are not possible.

(Connection box on top, cast feet, only basic versions possible, non-drive end (NDE) cannot be modified)

1) Only the type of construction IM B3 will be stamped on the rating plate.

2) Only the type of construction IM B5 will be stamped on the rating plate.

3) Only the type of construction IM B14 will be stamped on the rating plate.

# IEC Squirrel-Cage Motors

## New Generation 1LE1/1PC1

General Line motors with shorter delivery time

### Selection and ordering data (continued)

Order No.	Locked-rotor torque	Locked-rotor current	Breakdown torque	Torque class	Moment of inertia	Noise at rated output		Flange size according to DIN EN 50347
	with direct starting as multiple of rated torque	as multiple of rated current	torque			Measuring-surface sound pressure level at 50 Hz	Sound pressure level at 50 Hz	
	$T_{LR}/T_{rated}$	$I_{LR}/I_{rated}$	$T_B/T_{rated}$			CL	$J$ kgm <sup>2</sup>	
<b>Motor version: temperature class 155 (F), IP55 degree of protection, used acc. to temperature class 130 (B)</b>								
<b>4-pole – 1500 rpm at 50 Hz, 1800 rpm at 60 Hz</b>								
<b>230 VΔ/400 VY, 50 Hz; 460 VY, 60 Hz</b>								
• Without flange: IM B3, IM B6, IM B7, IM B8, IM V5 without protective cover, IM V6 <sup>1)</sup>								
- Without motor protection								
<b>1LE1002-1AB42-2AA0</b>	2.3	5.1	2.7	16	0.0059	60	72	
<b>1LE1002-1AB52-2AA0</b>	2.4	5.4	2.6	16	0.0078	60	72	
<b>1LE1002-1BB22-2AA0</b>	2.2	5.3	2.6	16	0.0102	58	70	
<b>1LE1002-1CB02-2AA0</b>	2.3	6.2	2.7	16	0.0186	64	76	
<b>1LE1002-1CB22-2AA0</b>	2.5	6.6	2.9	16	0.02371	64	76	
<b>1LE1002-1DB22-2AA0</b>	2.3	6.4	3.1	16	0.04395	65	77	
<b>1LE1002-1DB42-2AA0</b>	2.5	7	3.4	16	0.05616	65	77	
- With motor protection with PTC thermistors with 3 embedded temperature sensors for tripping								
<b>1LE1002-1AB42-2AB0</b>	2.3	5.1	2.7	16	0.0059	63	75	
• With flange: IM B5, IM V1 without protective cover, IM V3 <sup>2)</sup>								
- Without motor protection								
<b>1LE1002-1AB42-2FA0</b>	2.3	5.1	2.7	16	0.0059	60	72	FF 215
<b>1LE1002-1AB52-2FA0</b>	2.4	5.4	2.6	16	0.0078	60	72	FF 215
<b>1LE1002-1BB22-2FA0</b>	2.2	5.3	2.6	16	0.0102	58	70	FF 215
<b>1LE1002-1CB02-2FA0</b>	2.3	6.2	2.7	16	0.0186	64	76	FF 265
<b>1LE1002-1CB22-2FA0</b>	2.5	6.6	2.9	16	0.02371	64	76	FF 265
<b>1LE1002-1DB22-2FA0</b>	2.3	6.4	3.1	16	0.04395	65	77	FF 300
<b>1LE1002-1DB42-2FA0</b>	2.5	7	3.4	16	0.05616	65	77	FF 300
- With motor protection with PTC thermistors with 3 embedded temperature sensors for tripping								
<b>1LE1002-1AB42-2FB0</b>	2.3	5.1	2.7	16	0.0059	60	72	FF 215
<b>1LE1002-1AB52-2FB0</b>	2.4	5.4	2.6	16	0.0078	60	72	FF 215
<b>1LE1002-1BB22-2FB0</b>	2.2	5.3	2.6	16	0.0102	58	70	FF 215
• With standard flange: IM B14, IM V18 without protective cover, IM V19 <sup>3)</sup>								
- Without motor protection								
<b>1LE1002-1AB42-2KA0</b>	2.3	5.1	2.7	16	0.0059	60	72	FT 130
<b>1LE1002-1AB52-2KA0</b>	2.4	5.4	2.6	16	0.0078	63	75	FT 130
<b>1LE1002-1BB22-2KA0</b>	2.2	5.3	2.6	16	0.0102	58	70	FT 130

These motors are standard painted with special finish color RAL 7030 (stone gray).

Additional options like protective cover and condensation drainage holes are not possible.

(Connection box on top, cast feet, only basic versions possible, non-drive end (NDE) cannot be modified)

- 1) Only the type of construction IM B3 will be stamped on the rating plate.
- 2) Only the type of construction IM B5 will be stamped on the rating plate.
- 3) Only the type of construction IM B14 will be stamped on the rating plate.

# IEC Squirrel-Cage Motors

## New Generation 1LE1/1PC1

General Line motors with shorter delivery time

### Selection and ordering data (continued)

Rated output at		Frame size	Operating values at rated output							Order No.	Price	Weight
50 Hz	60 Hz		Rated speed at 50 Hz	Rated torque at 50 Hz	Efficiency Class according to CEMEP	Efficiency at 50 Hz 4/4-load	Efficiency at 50 Hz 3/4-load	Power factor at 4/4-load	Rated current at 400 V, 50 Hz			
$P_{rated}$ kW	$P_{rated}$ kW	FS	$n_{rated}$ rpm	$T_{rated}$ Nm	EFF2	$\eta_{rated}$ %	$\eta_{rated}$ %	$\cos\phi_{rated}$	$I_{rated}$ A		$m$ kg	
<b>Motor version: temperature class 155 (F), IP55 degree of protection, used acc. to temperature class 130 (B)</b>												
<b>4-pole – 1500 rpm at 50 Hz, 1800 rpm at 60 Hz</b>												
<b>400 V<math>\Delta</math>/690 VY, 50 Hz; 460 V<math>\Delta</math>, 60 Hz</b>												
• Without flange: IM B3, IM B6, IM B7, IM B8, IM V5 without protective cover, IM V6 <sup>1)</sup>												
- Without motor protection												
2.2	2.55	100 L	1425	14.8	EFF2	81	84	0.81	4.85	1LE1002-1AB43-4AA0	18	
3	3.45	100 L	1425	20.2	EFF2	82.8	83.6	0.85	6.2	1LE1002-1AB53-4AA0	22	
4	4.6	112 M	1435	27	EFF2	84.2	85.1	0.84	8.2	1LE1002-1BB23-4AA0	27	
5.5	6.3	132 S	1450	36	EFF2	86	86.5	0.83	11.2	1LE1002-1CB03-4AA0	38	
7.5	8.6	132 M	1450	49	EFF2	87	87.4	0.83	15	1LE1002-1CB23-4AA0	44	
11	12.6	160 M	1460	72	EFF2	88.4	88.1	0.82	22	1LE1002-1DB23-4AA0	62	
15	17.3	160 L	1460	98	EFF2	89.4	89.7	0.82	29.5	1LE1002-1DB43-4AA0	73	
- With motor protection with PTC thermistors with 3 embedded temperature sensors for tripping												
2.2	2.55	100 L	1425	14.8	EFF2	81	84	0.81	4.85	1LE1002-1AB43-4AB0	18	
3	3.45	100 L	1425	20.2	EFF2	82.8	83.6	0.85	6.2	1LE1002-1AB53-4AB0	22	
4	4.6	112 M	1435	27	EFF2	84.2	85.1	0.84	8.2	1LE1002-1BB23-4AB0	27	
5.5	6.3	132 S	1450	36	EFF2	86	86.5	0.83	11.2	1LE1002-1CB03-4AB0	38	
7.5	8.6	132 M	1450	49	EFF2	87	87.4	0.83	15	1LE1002-1CB23-4AB0	44	
11	12.6	160 M	1460	72	EFF2	88.4	88.1	0.82	22	1LE1002-1DB23-4AB0	62	
15	17.3	160 L	1460	98	EFF2	89.4	89.7	0.82	29.5	1LE1002-1DB43-4AB0	73	
• With flange: IM B5, IM V1 without protective cover, IM V3 <sup>2)</sup>												
- Without motor protection												
2.2	2.55	100 L	1425	14.8	EFF2	81	84	0.81	4.85	1LE1002-1AB43-4FA0	19	
3	3.45	100 L	1425	20.2	EFF2	82.8	83.6	0.85	6.2	1LE1002-1AB53-4FA0	23	
4	4.6	112 M	1435	27	EFF2	84.2	85.1	0.84	8.2	1LE1002-1BB23-4FA0	28	
5.5	6.3	132 S	1450	36	EFF2	86	86.5	0.83	11.2	1LE1002-1CB03-4FA0	43	
7.5	8.6	132 M	1450	49	EFF2	87	87.4	0.83	15	1LE1002-1CB23-4FA0	49	
11	12.6	160 M	1460	72	EFF2	88.4	88.1	0.82	22	1LE1002-1DB23-4FA0	71	
15	17.3	160 L	1460	98	EFF2	89.4	89.7	0.82	29.5	1LE1002-1DB43-4FA0	82	
- With motor protection with PTC thermistors with 3 embedded temperature sensors for tripping												
4	4.6	112 M	1435	27	EFF2	84.2	85.1	0.84	8.2	1LE1002-1BB23-4FB0	28	
5.5	6.3	132 S	1450	36	EFF2	86	86.5	0.83	11.2	1LE1002-1CB03-4FB0	43	
7.5	8.6	132 M	1450	49	EFF2	87	87.4	0.83	15	1LE1002-1CB23-4FB0	49	
11	12.6	160 M	1460	72	EFF2	88.4	88.1	0.82	22	1LE1002-1DB23-4FB0	71	
15	17.3	160 L	1460	98	EFF2	89.4	89.7	0.82	29.5	1LE1002-1DB43-4FB0	82	
• With flange: IM B35												
- Without motor protection												
5.5	6.3	132 S	1450	36	EFF2	86	86.5	0.83	11.2	1LE1002-1CB03-4JA0	43	
7.5	8.6	132 M	1450	49	EFF2	87	87.4	0.83	15	1LE1002-1CB23-4JA0	49	
11	12.6	160 M	1460	72	EFF2	88.4	88.1	0.82	22	1LE1002-1DB23-4JA0	71	
15	17.3	160 L	1460	98	EFF2	89.4	89.7	0.82	29.5	1LE1002-1DB43-4JA0	82	

These motors are standard painted with special finish color RAL 7030 (stone gray).

Additional options like protective cover and condensation drainage holes are not possible.

(Connection box on top, cast feet, only basic versions possible, non-drive end (NDE) cannot be modified)

<sup>1)</sup> Only the type of construction IM B3 will be stamped on the rating plate.

<sup>2)</sup> Only the type of construction IM B5 will be stamped on the rating plate.

# IEC Squirrel-Cage Motors

## New Generation 1LE1/1PC1

**General Line motors with shorter delivery time**
**Selection and ordering data (continued)**

Order No.	Locked-rotor torque	Locked-rotor current	Breakdown torque	Torque class	Moment of inertia	Noise at rated output		Flange size according to DIN EN 50347
	with direct starting as multiple of rated torque	as multiple of rated current	torque			Measuring-surface sound pressure level at 50 Hz	Sound pressure level at 50 Hz	
	$T_{LR}/T_{rated}$	$I_{LR}/I_{rated}$	$T_B/T_{rated}$	CL	$J$ kgm <sup>2</sup>	$L_{pFA}$ dB(A)	$L_{WA}$ dB(A)	
<b>Motor version: temperature class 155 (F), IP55 degree of protection, used acc. to temperature class 130 (B)</b>								
<b>4-pole – 1500 rpm at 50 Hz, 1800 rpm at 60 Hz</b>								
<b>400 VΔ/690 VY, 50 Hz; 460 VΔ, 60 Hz</b>								
• Without flange: IM B3, IM B6, IM B7, IM B8, IM V5 without protective cover, IM V6 <sup>1)</sup>								
- Without motor protection								
<b>1LE1002-1AB43-4AA0</b>	2.3	5.1	2.7	16	0.0059	60	72	
<b>1LE1002-1AB53-4AA0</b>	2.4	5.4	2.6	16	0.0078	60	72	
<b>1LE1002-1BB23-4AA0</b>	2.2	5.3	2.6	16	0.0102	58	70	
<b>1LE1002-1CB03-4AA0</b>	2.3	6.2	2.7	16	0.0186	64	76	
<b>1LE1002-1CB23-4AA0</b>	2.5	6.6	2.9	16	0.02371	64	76	
<b>1LE1002-1DB23-4AA0</b>	2.3	6.4	3.1	16	0.04395	65	77	
<b>1LE1002-1DB43-4AA0</b>	2.5	7	3.4	16	0.05616	65	77	
- With motor protection with PTC thermistors with 3 embedded temperature sensors for tripping								
<b>1LE1002-1AB43-4AB0</b>	2.3	5.1	2.7	16	0.0059	60	72	
<b>1LE1002-1AB53-4AB0</b>	2.4	5.4	2.6	16	0.0078	60	72	
<b>1LE1002-1BB23-4AB0</b>	2.2	5.3	2.6	16	0.0102	58	70	
<b>1LE1002-1CB03-4AB0</b>	2.3	6.2	2.7	16	0.0186	64	76	
<b>1LE1002-1CB23-4AB0</b>	2.5	6.6	2.9	16	0.02371	64	76	
<b>1LE1002-1DB23-4AB0</b>	2.3	6.4	3.1	16	0.04395	65	77	
<b>1LE1002-1DB43-4AB0</b>	2.5	7	3.4	16	0.05616	65	77	
• With flange: IM B5, IM V1 without protective cover, IM V3 <sup>2)</sup>								
- Without motor protection								
<b>1LE1002-1AB43-4FA0</b>	2.3	5.1	2.7	16	0.0059	60	72	FF 215
<b>1LE1002-1AB53-4FA0</b>	2.4	5.4	2.6	16	0.0078	60	72	FF 215
<b>1LE1002-1BB23-4FA0</b>	2.2	5.3	2.6	16	0.0102	58	70	FF 215
<b>1LE1002-1CB03-4FA0</b>	2.3	6.2	2.7	16	0.0186	64	76	FF 265
<b>1LE1002-1CB23-4FA0</b>	2.5	6.6	2.9	16	0.02371	64	76	FF 265
<b>1LE1002-1DB23-4FA0</b>	2.3	6.4	3.1	16	0.04395	65	77	FF 300
<b>1LE1002-1DB43-4FA0</b>	2.5	7	3.4	16	0.05616	65	77	FF 300
- With motor protection with PTC thermistors with 3 embedded temperature sensors for tripping								
<b>1LE1002-1BB23-4FB0</b>	2.2	5.3	2.6	16	0.0102	58	70	FF 215
<b>1LE1002-1CB03-4FB0</b>	2.3	6.2	2.7	16	0.0186	64	76	FF 265
<b>1LE1002-1CB23-4FB0</b>	2.5	6.6	2.9	16	0.02371	64	76	FF 265
<b>1LE1002-1DB23-4FB0</b>	2.3	6.4	3.1	16	0.04395	65	77	FF 300
<b>1LE1002-1DB43-4FB0</b>	2.5	7	3.4	16	0.05616	65	77	FF 300
• With flange: IM B35								
- Without motor protection								
<b>1LE1002-1CB03-4JA0</b>	2.3	6.2	2.7	16	0.0186	64	76	FF 265
<b>1LE1002-1CB23-4JA0</b>	2.5	6.6	2.9	16	0.02371	64	76	FF 265
<b>1LE1002-1DB23-4JA0</b>	2.3	6.4	3.1	16	0.04395	65	77	FF 300
<b>1LE1002-1DB43-4JA0</b>	2.5	7	3.4	16	0.05616	65	77	FF 300

These motors are standard painted with special finish color RAL 7030 (stone gray).

Additional options like protective cover and condensation drainage holes are not possible.

(Connection box on top, cast feet, only basic versions possible, non-drive end (NDE) cannot be modified)

<sup>1)</sup> Only the type of construction IM B3 will be stamped on the rating plate.

<sup>2)</sup> Only the type of construction IM B5 will be stamped on the rating plate.

# IEC Squirrel-Cage Motors

## New Generation 1LE1/1PC1

General Line motors with shorter delivery time

### Selection and ordering data (continued)

Rated output at		Frame size	Operating values at rated output							Order No.	Price	Weight
50 Hz	60 Hz		Rated speed at 50 Hz	Rated torque at 50 Hz	Efficiency Class according to CEMEP	Efficiency at 50 Hz 4/4-load	Efficiency at 50 Hz 3/4-load	Power factor at 4/4-load	Rated current at 400 V, 50 Hz			
$P_{rated}$ kW	$P_{rated}$ kW	FS	$n_{rated}$ rpm	$T_{rated}$ Nm		$\eta_{rated}$ %	$\eta_{rated}$ %	$\cos\phi_{rated}$	$I_{rated}$ A		$m$ kg	
<b>Motor version: temperature class 155 (F), IP55 degree of protection, used acc. to temperature class 130 (B)</b>												
<b>6-pole – 1000 rpm at 50 Hz, 1200 rpm at 60 Hz</b>												
<b>230 VΔ/400 VY, 50 Hz; 460 VY, 60 Hz</b>												
• Without flange: IM B3, IM B6, IM B7, IM B8, IM V5 without protective cover, IM V6 <sup>1)</sup>												
- Without motor protection												
1.5	1.75	100 L	940	15.3		74	72.6	0.74	3.95	<b>1LE1002-1AC42-2AA0</b>	19	
2.2	2.55	112 M	930	23		78	78.1	0.77	5.3	<b>1LE1002-1BC22-2AA0</b>	25	
3	3.45	132 S	955	30		80	79.4	0.74	7.3	<b>1LE1002-1CC02-2AA0</b>	34	
4	4.6	132 M	950	40		83	83.4	0.76	9.2	<b>1LE1002-1CC22-2AA0</b>	39	
5.5	6.3	132 M	950	55		85	85.3	0.75	12.4	<b>1LE1002-1CC32-2AA0</b>	48	
• With flange: IM B5, IM V1 without protective cover, IM V3 <sup>2)</sup>												
- Without motor protection												
1.5	1.75	100 L	940	15.3		74	72.6	0.74	3.95	<b>1LE1002-1AC42-2FA0</b>	20	
2.2	2.55	112 M	930	23		78	78.1	0.77	5.3	<b>1LE1002-1BC22-2FA0</b>	26	
3	3.45	132 S	955	30		80	79.4	0.74	7.3	<b>1LE1002-1CC02-2FA0</b>	39	
4	4.6	132 M	950	40		83	83.4	0.76	9.2	<b>1LE1002-1CC22-2FA0</b>	44	
- With motor protection with PTC thermistors with 3 embedded temperature sensors for tripping												
1.5	1.75	100 L	940	15.3		74	72.6	0.74	3.95	<b>1LE1002-1AC42-2FB0</b>	20	
2.2	2.55	112 M	930	23		78	78.1	0.77	5.3	<b>1LE1002-1BC22-2FB0</b>	26	
3	3.45	132 S	955	30		80	79.4	0.74	7.3	<b>1LE1002-1CC02-2FB0</b>	39	
• With standard flange: IM B14, IM V18 without protective cover, IM V19 <sup>3)</sup>												
- Without motor protection												
1.5	1.75	100 L	940	15.3		74	72.6	0.74	3.95	<b>1LE1002-1AC42-2KA0</b>	21	
2.2	2.55	112 M	930	23		78	78.1	0.77	5.3	<b>1LE1002-1BC22-2KA0</b>	27	
<b>400 VΔ/690 VY, 50 Hz; 460 VΔ, 60 Hz</b>												
• Without flange: IM B3, IM B6, IM B7, IM B8, IM V5 without protective cover, IM V6 <sup>1)</sup>												
- Without motor protection												
3	3.45	132 S	955	30		80	79.4	0.74	7.3	<b>1LE1002-1CC03-4AA0</b>	34	
4	4.6	132 M	950	40		83	83.4	0.76	9.2	<b>1LE1002-1CC23-4AA0</b>	39	
5.5	6.3	132 M	950	55		85	85.3	0.75	12.4	<b>1LE1002-1CC33-4AA0</b>	48	
7.5	8.6	160 M	970	75		86	85.4	0.73	17.2	<b>1LE1002-1DC23-4AA0</b>	72	
11	12.6	160 L	965	110		87.6	87.9	0.77	23.5	<b>1LE1002-1DC43-4AA0</b>	92	
- With motor protection with PTC thermistors with 3 embedded temperature sensors for tripping												
3	3.45	132 S	955	30		80	79.4	0.74	7.3	<b>1LE1002-1CC03-4AB0</b>	34	
4	4.6	132 M	950	40		83	83.4	0.76	9.2	<b>1LE1002-1CC23-4AB0</b>	39	
5.5	6.3	132 M	950	55		85	85.3	0.75	12.4	<b>1LE1002-1CC33-4AB0</b>	48	
7.5	8.6	160 M	970	75		86	86.5	0.73	17.2	<b>1LE1002-1DC23-4AB0</b>	72	
11	12.6	160 L	965	110		87.6	87.9	0.77	23.5	<b>1LE1002-1DC43-4AB0</b>	92	
• With flange: IM B5, IM V1 without protective cover, IM V3 <sup>2)</sup>												
- Without motor protection												
3	3.45	132 S	955	30		80	79.4	0.74	7.3	<b>1LE1002-1CC03-4FA0</b>	39	
4	4.6	132 M	950	40		83	83.4	0.76	9.2	<b>1LE1002-1CC23-4FA0</b>	44	
5.5	6.3	132 M	950	55		85	85.3	0.75	12.4	<b>1LE1002-1CC33-4FA0</b>	53	
7.5	8.6	160 M	970	75		86	85.4	0.73	17.2	<b>1LE1002-1DC23-4FA0</b>	81	
11	12.6	160 L	965	110		87.6	87.9	0.77	23.5	<b>1LE1002-1DC43-4FA0</b>	101	
- With motor protection with PTC thermistors with 3 embedded temperature sensors for tripping												
4	4.6	132 M	950	40		83	83.4	0.76	9.2	<b>1LE1002-1CC23-4FB0</b>	44	
5.5	6.3	132 M	950	55		85	85.3	0.75	12.4	<b>1LE1002-1CC33-4FB0</b>	53	
7.5	8.6	160 M	970	75		86	85.4	0.73	17.2	<b>1LE1002-1DC23-4FB0</b>	81	
11	12.6	160 L	965	110		87.6	87.9	0.77	23.5	<b>1LE1002-1DC43-4FB0</b>	101	

These motors are standard painted with special finish color RAL 7030 (stone gray).

Additional options like protective cover and condensation drainage holes are not possible.

(Connection box on top, cast feet, only basic versions possible, non-drive end (NDE) cannot be modified)

1) Only the type of construction IM B3 will be stamped on the rating plate.

2) Only the type of construction IM B5 will be stamped on the rating plate.

3) Only the type of construction IM B14 will be stamped on the rating plate.

# IEC Squirrel-Cage Motors

## New Generation 1LE1/1PC1

General Line motors with shorter delivery time

### Selection and ordering data (continued)

Order No.	Locked-rotor torque	Locked-rotor current	Breakdown torque	Torque class	Moment of inertia	Noise at rated output		Flange size according to DIN EN 50347
	with direct starting as multiple of rated torque	as multiple of rated current	torque			Measuring-surface sound pressure level at 50 Hz	Sound pressure level at 50 Hz	
	$T_{LR}/T_{rated}$	$I_{LR}/I_{rated}$	$T_B/T_{rated}$	CL	$J$ kgm <sup>2</sup>	$L_{pFA}$ dB(A)	$L_{WA}$ dB(A)	
<b>Motor version: temperature class 155 (F), IP55 degree of protection, used acc. to temperature class 130 (B)</b>								
<b>6-pole – 1000 rpm at 50 Hz, 1200 rpm at 60 Hz</b>								
<b>230 V<math>\Delta</math>/400 VY, 50 Hz; 460 VY, 60 Hz</b>								
• Without flange: IM B3, IM B6, IM B7, IM B8, IM V5 without protective cover, IM V6 <sup>1)</sup>								
- Without motor protection								
<b>1LE1002-1AC42-2AA0</b>	2	4	2.2	16	0.0065	59	71	
<b>1LE1002-1BC22-2AA0</b>	2.1	4.1	2.4	16	0.0065	57	69	
<b>1LE1002-1CC02-2AA0</b>	2	4.6	2.6	16	0.0167	63	75	
<b>1LE1002-1CC22-2AA0</b>	2.1	4.7	2.5	16	0.02116	63	75	
<b>1LE1002-1CC32-2AA0</b>	2.5	5.2	2.8	16	0.02734	63	75	
• With flange: IM B5, IM V1 without protective cover, IM V3 <sup>2)</sup>								
- Without motor protection								
<b>1LE1002-1AC42-2FA0</b>	2	4	2.2	16	0.0065	59	71	FF 215
<b>1LE1002-1BC22-2FA0</b>	2.3	4.1	2.5	16	0.0092	57	69	FF 215
<b>1LE1002-1CC02-2FA0</b>	2	4.6	2.6	16	0.0167	63	75	FF 265
<b>1LE1002-1CC22-2FA0</b>	2.1	4.7	2.5	16	0.02116	63	75	FF 265
- With motor protection with PTC thermistors with 3 embedded temperature sensors for tripping								
<b>1LE1002-1AC42-2FB0</b>	2	4	2.2	16	0.0065	59	71	FF 215
<b>1LE1002-1BC22-2FB0</b>	2.3	4.1	2.5	16	0.0092	68	80	FF 215
<b>1LE1002-1CC02-2FB0</b>	2	4.6	2.6	16	0.0167	63	75	FF 265
• With standard flange: IM B14, IM V18 without protective cover, IM V19 <sup>3)</sup>								
- Without motor protection								
<b>1LE1002-1AC42-2KA0</b>	2	4	2.2	16	0.0065	59	71	FT 130
<b>1LE1002-1BC22-2KA0</b>	2.3	4.1	2.5	16	0.0092	68	80	FT 130
<b>400 V<math>\Delta</math>/690 VY, 50 Hz; 460 V<math>\Delta</math>, 60 Hz</b>								
• Without flange: IM B3, IM B6, IM B7, IM B8, IM V5 without protective cover, IM V6 <sup>1)</sup>								
- Without motor protection								
<b>1LE1002-1CC03-4AA0</b>	2	4.6	2.6	16	0.017	63	75	
<b>1LE1002-1CC23-4AA0</b>	2.1	4.7	2.5	16	0.02116	63	75	
<b>1LE1002-1CC33-4AA0</b>	2.5	5.2	2.8	16	0.02734	63	75	
<b>1LE1002-1DC23-4AA0</b>	2.1	5.5	2.9	16	0.04993	68	80	
<b>1LE1002-1DC43-4AA0</b>	1.9	5.9	2.7	16	0.0678	68	80	
- With motor protection with PTC thermistors with 3 embedded temperature sensors for tripping								
<b>1LE1002-1CC03-4AB0</b>	2	4.6	2.6	16	0.0167	63	75	
<b>1LE1002-1CC23-4AB0</b>	2.1	4.7	2.5	16	0.02116	63	75	
<b>1LE1002-1CC33-4AB0</b>	2.5	5.2	2.8	16	0.02734	63	75	
<b>1LE1002-1DC23-4AB0</b>	2.1	5.5	2.9	16	0.04993	68	80	
<b>1LE1002-1DC43-4AB0</b>	1.9	5.9	2.7	16	0.0678	68	80	
• With flange: IM B5, IM V1 without protective cover, IM V3 <sup>2)</sup>								
- Without motor protection								
<b>1LE1002-1CC03-4FA0</b>	2	4.6	2.6	16	0.0167	63	75	FF 265
<b>1LE1002-1CC23-4FA0</b>	2.1	4.7	2.5	16	0.02116	63	75	FF 265
<b>1LE1002-1CC33-4FA0</b>	2.5	5.2	2.8	16	0.02734	63	75	FF 265
<b>1LE1002-1DC23-4FA0</b>	2.1	5.5	2.9	16	0.04993	68	80	FF 300
<b>1LE1002-1DC43-4FA0</b>	1.9	5.9	2.7	16	0.0678	68	80	FF 300
- With motor protection with PTC thermistors with 3 embedded temperature sensors for tripping								
<b>1LE1002-1CC23-4FB0</b>	2.1	4.7	2.5	16	0.02116	63	75	FF 265
<b>1LE1002-1CC33-4FB0</b>	2.5	5.2	2.8	16	0.02734	63	75	FF 265
<b>1LE1002-1DC23-4FB0</b>	2.1	5.5	2.9	16	0.04993	68	80	FF 300
<b>1LE1002-1DC43-4FB0</b>	1.9	5.9	2.7	16	0.0678	68	80	FF 300

These motors are standard painted with special finish color RAL 7030 (stone gray).

Additional options like protective cover and condensation drainage holes are not possible.

(Connection box on top, cast feet, only basic versions possible, non-drive end (NDE) cannot be modified)

- 1) Only the type of construction IM B3 will be stamped on the rating plate.
- 2) Only the type of construction IM B5 will be stamped on the rating plate.
- 3) Only the type of construction IM B14 will be stamped on the rating plate.

# IEC Squirrel-Cage Motors

## New Generation 1LE1/1PC1

Self-ventilated energy-saving motors  
with improved efficiency

### Selection and ordering data

Rated output at		Frame size	Operating values at rated output							Order No.	Price	Weight
50 Hz	60 Hz		Rated speed at 50 Hz	Rated torque at 50 Hz	Efficiency Class according to CEMEP	Efficiency at 50 Hz 4/4-load	Efficiency at 50 Hz 3/4-load	Power factor at 50 Hz 4/4-load	Rated current at 400 V, 50 Hz			
$P_{\text{rated}}$ kW	$P_{\text{rated}}$ kW	FS	$n_{\text{rated}}$ rpm	$T_{\text{rated}}$ Nm		$\eta_{\text{rated}}$ %	$\eta_{\text{rated}}$ %	$\cos\varphi_{\text{rated}}$	$I_{\text{rated}}$ A	For Order No. supplements for voltage, type of construction, motor protection and connection box, see table from Page 1/20.	IM B3 type of construction	IM B3 type of construction approx. m kg
<b>Motor version: temperature class 155 (F), IP55 degree of protection, used acc. to temperature class 130 (B)</b>												
<b>2-pole – 3000 rpm at 50 Hz, 3600 rpm at 60 Hz</b>												
3	3.45	100 L	2835	10	EFF2	82.6	83.2	0.87	6	<b>1LE1002-1AA4Q-QQQQ</b>		20
4	4.6	112 M	2930	13	EFF2	84.8	84.4	0.86	7.9	<b>1LE1002-1BA2Q-QQQQ</b>		25
5.5	6.3	132 S	2905	18	EFF2	86	86.6	0.89	10.4	<b>1LE1002-1CA0Q-QQQQ</b>		35
7.5	8.6	132 S	2925	24	EFF2	87.6	88.7	0.88	14	<b>1LE1002-1CA1Q-QQQQ</b>		40
11	12.6	160 M	2920	36	EFF2	88.4	88.5	0.85	21	<b>1LE1002-1DA2Q-QQQQ</b>		60
15	17.3	160 M	2930	49	EFF2	89.5	89.7	0.84	29	<b>1LE1002-1DA3Q-QQQQ</b>		68
18.5	21.3	160 L	2935	60	EFF2	90.9	91	0.86	34	<b>1LE1002-1DA4Q-QQQQ</b>		78
<b>4-pole – 1500 rpm at 50 Hz, 1800 rpm at 60 Hz</b>												
2.2	2.55	100 L	1425	14.8	EFF2	81	84	0.81	4.85	<b>1LE1002-1AB4Q-QQQQ</b>		18
3	3.45	100 L	1425	20.2	EFF2	82.8	83.6	0.85	6.2	<b>1LE1002-1AB5Q-QQQQ</b>		22
4	4.6	112 M	1435	27	EFF2	84.2	85.1	0.84	8.2	<b>1LE1002-1BB2Q-QQQQ</b>		27
5.5	6.3	132 S	1450	36	EFF2	86	86.5	0.83	11.2	<b>1LE1002-1CB0Q-QQQQ</b>		38
7.5	8.6	132 M	1450	49	EFF2	87	87.4	0.83	15	<b>1LE1002-1CB2Q-QQQQ</b>		44
11	12.6	160 M	1460	72	EFF2	88.4	88.1	0.82	22	<b>1LE1002-1DB2Q-QQQQ</b>		62
15	17.3	160 L	1460	98	EFF2	89.4	89.7	0.82	29.5	<b>1LE1002-1DB4Q-QQQQ</b>		73
<b>6-pole – 1000 rpm at 50 Hz, 1200 rpm at 60 Hz</b>												
1.5	1.75	100 L	940	15.3		74	72.6	0.74	3.95	<b>1LE1002-1AC4Q-QQQQ</b>		19
2.2	2.55	112 M	930	23		78	78.1	0.77	5.3	<b>1LE1002-1BC2Q-QQQQ</b>		25
3	3.45	132 S	955	30		80	79.4	0.74	7.3	<b>1LE1002-1CC0Q-QQQQ</b>		34
4	4.6	132 M	950	40		83	83.4	0.76	9.2	<b>1LE1002-1CC2Q-QQQQ</b>		39
5.5	6.3	132 M	950	55		85	85.3	0.75	12.4	<b>1LE1002-1CC3Q-QQQQ</b>		48
7.5	8.6	160 M	970	75		86	85.4	0.73	17.2	<b>1LE1002-1DC2Q-QQQQ</b>		72
11	12.6	160 L	965	110		87.6	87.9	0.77	23.5	<b>1LE1002-1DC4Q-QQQQ</b>		92
<b>8-pole – 750 rpm at 50 Hz, 900 rpm at 60 Hz</b>												
0.75	0.86	100 L	705	10.4		65.4	60.2	0.62	2.65	<b>1LE1002-1AD4Q-QQQQ</b>		17
1.1	1.3	100 L	705	15.1		68.3	67.6	0.63	3.7	<b>1LE1002-1AD5Q-QQQQ</b>		22
1.5	1.75	112 M	700	20		75.9	72.8	0.68	4.2	<b>1LE1002-1BD2Q-QQQQ</b>		25
2.2	2.55	132 S	715	29		81	80.4	0.66	5.9	<b>1LE1002-1CD0Q-QQQQ</b>		37
3	3.45	132 M	710	40		81.6	81.4	0.68	7.8	<b>1LE1002-1CD2Q-QQQQ</b>		44
4	4.6	160 M	720	53		80	78.7	0.69	10.4	<b>1LE1002-1DD2Q-QQQQ</b>		60
5.5	6.3	160 M	720	73		83.5	83.9	0.70	13.6	<b>1LE1002-1DD3Q-QQQQ</b>		72
7.5	8.6	160 L	715	100		83.5	84.7	0.70	18.6	<b>1LE1002-1DD4Q-QQQQ</b>		91

#### Note:

The 2-, 4-, and 6-pole motors listed above can be delivered ex stock with shorter delivery time.  
These motors can be selected from defined versions (voltages, types of construction, motor protection and position of the connection box) in section "General Line motors with shorter delivery time" on Pages 1/8 to 1/17.

Order No. supplements, see from Page 1/20.



# IEC Squirrel-Cage Motors

## New Generation 1LE1/1PC1

Self-ventilated energy-saving motors  
with improved efficiency

### Selection and ordering data (continued)

Order No.	Locked-rotor torque	Locked-rotor current	Breakdown torque	Torque class	Moment of inertia	Noise at rated output	
	with direct starting torque	as multiple of rated current	torque			Measuring-surface sound pressure level at 50 Hz	Sound pressure level at 50 Hz
	$T_{LR}/T_{rated}$	$I_{LR}/I_{rated}$	$T_B/T_{rated}$	CL	$J$ kgm <sup>2</sup>	$L_{pFA}$ dB(A)	$L_{WA}$ dB(A)
<b>Motor version: temperature class 155 (F), IP55 degree of protection, used acc. to temperature class 130 (B)</b>							
<b>2-pole – 3000 rpm at 50 Hz, 3600 rpm at 60 Hz</b>							
1LE1002-1AA4Q-QQQQ	3.2	6.2	2.9	16	0.0034	67	79
1LE1002-1BA2Q-QQQQ	2.7	7.3	3.7	16	0.0067	69	81
1LE1002-1CA0Q-QQQQ	2	5.6	2.6	16	0.01267	68	80
1LE1002-1CA1Q-QQQQ	2.2	6.4	3	16	0.01601	68	80
1LE1002-1DA2Q-QQQQ	2.1	6.1	2.7	16	0.02971	70	82
1LE1002-1DA3Q-QQQQ	2.5	6.1	3.2	16	0.03619	70	82
1LE1002-1DA4Q-QQQQ	2.5	7	3.2	16	0.04395	70	82
<b>4-pole – 1500 rpm at 50 Hz, 1800 rpm at 60 Hz</b>							
1LE1002-1AB4Q-QQQQ	2.3	5.1	2.7	16	0.0059	60	72
1LE1002-1AB5Q-QQQQ	2.4	5.4	2.6	16	0.0078	60	72
1LE1002-1BB2Q-QQQQ	2.2	5.3	2.6	16	0.0102	58	70
1LE1002-1CB0Q-QQQQ	2.3	6.2	2.7	16	0.0186	64	76
1LE1002-1CB2Q-QQQQ	2.5	6.6	2.9	16	0.02371	64	76
1LE1002-1DB2Q-QQQQ	2.3	6.4	3.1	16	0.04395	65	77
1LE1002-1DB4Q-QQQQ	2.5	7	3.4	16	0.05616	65	77
<b>6-pole – 1000 rpm at 50 Hz, 1200 rpm at 60 Hz</b>							
1LE1002-1AC4Q-QQQQ	2	4	2.2	16	0.0065	61	73
1LE1002-1BC2Q-QQQQ	2.3	4.1	2.5	16	0.0092	68	80
1LE1002-1CC0Q-QQQQ	2	4.6	2.6	16	0.0167	63	75
1LE1002-1CC2Q-QQQQ	2.1	4.7	2.5	16	0.02116	63	75
1LE1002-1CC3Q-QQQQ	2.5	5.2	2.8	16	0.02734	63	75
1LE1002-1DC2Q-QQQQ	2.1	5.5	2.9	16	0.04993	68	80
1LE1002-1DC4Q-QQQQ	1.9	5.9	2.7	16	0.0678	68	80
<b>8-pole – 750 rpm at 50 Hz, 900 rpm at 60 Hz</b>							
1LE1002-1AD4Q-QQQQ	1.9	3	2.2	16	0.0056	60	72
1LE1002-1AD5Q-QQQQ	2	3.2	2.3	16	0.0078	60	72
1LE1002-1BD2Q-QQQQ	1.9	3.4	2.1	16	0.0094	63	75
1LE1002-1CD0Q-QQQQ	1.7	3.9	2.4	13	0.0186	63	75
1LE1002-1CD2Q-QQQQ	1.8	3.9	2.2	13	0.02372	63	75
1LE1002-1DD2Q-QQQQ	1.7	3.8	2.3	13	0.0439	63	75
1LE1002-1DD3Q-QQQQ	1.6	4	2.2	13	0.0562	63	75
1LE1002-1DD4Q-QQQQ	1.7	3.8	2.2	13	0.0772	63	75

# IEC Squirrel-Cage Motors

## New Generation 1LE1/1PC1

**Self-ventilated energy-saving motors with improved efficiency**

### Selection and ordering data (continued)

#### Order No. supplements

Motor type	Frame size	Positions 12 and 13: Voltages (voltage codes)							
		Standard voltages				Further voltages			
		50 Hz				50 Hz			
		230 VΔ/400 VY	400 VΔ/690 VY	500 VY	500 VΔ	220 VΔ/380 VY	380 VΔ/660 VY	415 VY	415 VΔ
		<u>60 Hz</u>				<u>Rated voltage range</u>			
		460 VY	460 VΔ			(210 ... 230 VΔ/ 360 ... 400 VY) <sup>1)</sup>	(360 ... 400 VΔ/ 625 ... 695 VY) <sup>1)</sup>	(395 ... 435 VY) <sup>1)</sup>	(395 ... 435 VΔ) <sup>1)</sup>
		see "Selection and ordering data" for outputs at 60 Hz							
		<b>22</b>	<b>34</b>	<b>27</b>	<b>40</b>	<b>21</b>	<b>33</b>	<b>23</b>	<b>35</b>
1LE1002-1A...-□-□...	100 L	○	○	○	○	✓	✓	✓	✓
1LE1002-1B...-□-□...	112 M	○	○	○	○	✓	✓	✓	✓
1LE1002-1C...-□-□...	132 S/M	○	○	○	○	✓	✓	✓	✓
1LE1002-1D...-□-□...	160 M/L	○	○	○	○	✓	✓	✓	✓

- Without additional charge
- ✓ With additional charge

Order other voltages with voltage code **9** in position 12, code **0** in position 13 and the corresponding order code (see "Special versions" in the "Selection and ordering data" under "Voltages", Page 1/54).

Motor type	Frame size	Position 14: Types of construction (type letter)												
		Without flange							With flange (acc. to DIN EN 50347)					
		IM B3 <sup>2)3)</sup>	IM B6 <sup>3)</sup>	IM B7 <sup>3)</sup>	IM B8 <sup>3)</sup>	IM V6 <sup>3)</sup>	IM V5 without protective cover <sup>3)</sup>	IM V5 with protective cover <sup>3)4)5)</sup>	Flange size	IM B5 <sup>3)6)</sup>	IM V1 without protective cover <sup>3)</sup>	IM V1 with protective cover <sup>3)4)5)</sup>	IM V3 <sup>3)</sup>	IM B35
		<b>A</b>	<b>T</b>	<b>U</b>	<b>V</b>	<b>D</b>	<b>C</b>	<b>C</b>	<b>F</b>	<b>G</b>	<b>G</b>	<b>H</b>	<b>J</b>	
		Order No. supplement -Z with order code												
		-	-	-	-	-	-	<b>-Z H00</b>	-	-	<b>-Z H00</b>	-	-	
1LE1002-1A...-□-□...	100 L	□	□	□	□	□	□	✓	<b>FF 215</b>	✓	✓	✓	✓	
1LE1002-1B...-□-□...	112 M	□	□	□	□	□	□	✓	<b>FF 215</b>	✓	✓	✓	✓	
1LE1002-1C...-□-□...	132 S/M	□	□	□	□	□	□	✓	<b>FF 265</b>	✓	✓	✓	✓	
1LE1002-1D...-□-□...	160 M/L	□	□	□	□	□	□	✓	<b>FF 300</b>	✓	✓	✓	✓	

Motor type	Frame size	Position 14: Types of construction (type letter)												
		With standard flange (acc. to DIN EN 50347)						With standard flange (next larger standard flange acc. to DIN EN 50347)						
		Flange size	IM B14 <sup>3)7)</sup>	IM V19 <sup>3)</sup>	IM V18 without protective cover <sup>3)</sup>	IM V18 with protective cover <sup>3)4)5)</sup>	IM B34	Flange size	IM B14 <sup>3)7)</sup>	IM V19 <sup>3)</sup>	IM V18 without protective cover <sup>3)</sup>	IM V18 with protective cover <sup>3)4)5)</sup>	IM B34	
			<b>K</b>	<b>L</b>	<b>M</b>	<b>M</b>	<b>N</b>		<b>K</b>	<b>L</b>	<b>M</b>	<b>M</b>	<b>N</b>	
		Order No. supplement -Z with order code												
		-	-	-	-	<b>-Z H00</b>	-	<b>-Z</b>	<b>-Z</b>	<b>-Z</b>	<b>-Z</b>	<b>-Z H00</b>	<b>-Z</b>	
			<b>P01</b>	<b>P01</b>	<b>P01</b>	<b>P01</b>	<b>P01</b>		<b>P01</b>	<b>P01</b>	<b>P01</b>	<b>P01</b>	<b>P01</b>	
1LE1002-1A...-□-□...	100 L	<b>FT 130</b>	✓	✓	✓	✓	✓	<b>FT 165</b>	✓	✓	✓	✓	✓	
1LE1002-1B...-□-□...	112 M	<b>FT 130</b>	✓	✓	✓	✓	✓	<b>FT 165</b>	✓	✓	✓	✓	✓	
1LE1002-1C...-□-□...	132 S/M	<b>FT 165</b>	✓	✓	✓	✓	✓	<b>FT 215</b>	✓	✓	✓	✓	✓	
1LE1002-1D...-□-□...	160 M/L	<b>FT 215</b>	✓	✓	✓	✓	✓	-	-	-	-	-	-	

- Standard version
- ✓ With additional charge

<sup>1)</sup> A rated voltage range is also specified on the rating plate.  
<sup>2)</sup> The types of construction IM B6/7/8, IM V6 and IM V5 without protective cover/with protective cover are also possible as long as no condensation drainage holes (order code **H03**) and no stamping of these types of construction on the rating plate are required. As standard, the type of construction IM B3 is then stamped on the rating plate. With type of construction IM V5 with protective cover, the protective cover has to be additionally ordered with order code **H00**. The protective cover is not stamped on the rating plate.  
<sup>3)</sup> The type of construction is stamped on the rating plate. When ordering with condensation drainage holes (order code **H03**), it is absolutely necessary to specify the type of construction for the exact position of the condensation drainage holes during manufacture.  
<sup>4)</sup> Option second shaft extension (order code **L05**) not possible.

<sup>5)</sup> In combination with an encoder, it is not necessary to order the protective cover (order code **H00**), as this is delivered as a protection for the encoder as standard. In this case, the protective cover is standard design (without additional charge).  
<sup>6)</sup> The types of construction IM V3 and IM V1 without protective cover/with protective cover are also possible as long as no condensation drainage holes (order code **H03**) and no stamping of these types of construction on the rating plate are required. As standard, the type of construction IM B5 is then stamped on the rating plate. With type of construction IM V1 with protective cover, the protective cover has to be additionally ordered with order code **H00**. The protective cover is not stamped on the rating plate.  
<sup>7)</sup> The types of construction IM V19 and IM V18 without protective cover/with protective cover are also possible as long as no condensation drainage holes (order code **H03**) and no stamping of these types of construction on the rating plate are required. As standard, the type of construction IM B14 is then stamped on the rating plate. With type of construction IM V18 with protective cover, the protective cover has to be additionally ordered with order code **H00**. The protective cover is not stamped on the rating plate.

# IEC Squirrel-Cage Motors

## New Generation 1LE1/1PC1

Self-ventilated energy-saving motors  
with improved efficiency

### Selection and ordering data (continued)

Motor type	Frame size	Position 15: Motor protection (motor protection letter)					
		Without motor protection	Motor protection with PTC thermistors with 3 embedded temperature sensors for tripping <sup>1)</sup>	Motor protection with PTC thermistors with 6 embedded temperature sensors for alarm and tripping <sup>1)</sup>	Motor temperature detection with embedded temperature sensor KTY 84-130 <sup>1)</sup>	NTC thermistors for tripping	Temperature detectors for tripping <sup>1)</sup>
Order code		A	B	C	F	Z Q2A	Z Q3A
1LE1002-1A...-...□	100 L	□	✓	✓	✓	✓	✓
1LE1002-1B...-...□	112 M	□	✓	✓	✓	✓	✓
1LE1002-1C...-...□	132 S/M	□	✓	✓	✓	✓	✓
1LE1002-1D...-...□	160 M/L	□	✓	✓	✓	✓	✓

- Standard version  
✓ With additional charge

Motortyp	Frame size	Position 16: Connection box (connection box code)			
		Connection box top <sup>2)</sup>	Connection box on RHS <sup>3)</sup>	Connection box on LHS <sup>3)</sup>	Connection box bottom <sup>3)</sup>
		4	5	6	7
1LE1002-1A...-...□	100 L	□	✓	✓	✓
1LE1002-1B...-...□	112 M	□	✓	✓	✓
1LE1002-1C...-...□	132 S/M	□	✓	✓	✓
1LE1002-1D...-...□	160 M/L	□	✓	✓	✓

- Standard version  
✓ With additional charge

<sup>1)</sup> Evaluation with appropriate tripping unit (see Catalog LV 1) is recommended.  
<sup>2)</sup> With type of construction, cast feet as standard. Screwed-on feet are available with order code **H01**, see "Special versions".  
<sup>3)</sup> With type of construction, screwed-on feet as standard.

# IEC Squirrel-Cage Motors

## New Generation 1LE1/1PC1

Self-ventilated energy-saving motors  
with high efficiency

### Selection and ordering data

Rated output at		Frame size	Operating values at rated output							Order No.	Price	Weight
50 Hz	60 Hz		Rated speed at 50 Hz	Rated torque at 50 Hz	Efficiency Class according to CEMEP	Efficiency at 50 Hz 4/4-load	Efficiency at 50 Hz 3/4-load	Power factor at 50 Hz 4/4-load	Rated current at 400 V, 50 Hz			
$P_{\text{rated}}$ kW	$P_{\text{rated}}$ kW	FS	$n_{\text{rated}}$ rpm	$T_{\text{rated}}$ Nm		$\eta_{\text{rated}}$ %	$\eta_{\text{rated}}$ %	$\cos\varphi_{\text{rated}}$	$I_{\text{rated}}$ A	For Order No. supplements for voltage, type of construction, motor protection and connection box, see table from Page 1/24.	IM B3 type of construction	IM B3 type of construction approx. m kg
<b>Motor version: temperature class 155 (F), IP55 degree of protection, used acc. to temperature class 130 (B)</b>												
<b>For use according to CEMEP</b>												
<b>2-pole – 3000 rpm at 50 Hz, 3600 rpm at 60 Hz</b>												
3	3.45	100 L	2905	9.9	EFF1	86.7	87.5	0.84	5.9	<b>1LE1001-1AA4Q-QQQQ</b>		21
4	4.6	112 M	2950	13	EFF1	88	88.5	0.86	7.4	<b>1LE1001-1BA2Q-QQQQ</b>		27
5.5	6.3	132 S	2950	18	EFF1	89.5	90.6	0.87	10.2	<b>1LE1001-1CA0Q-QQQQ</b>		39
7.5	8.6	132 S	2950	24	EFF1	90	91	0.87	13.8	<b>1LE1001-1CA1Q-QQQQ</b>		43
11	12.6	160 M	2955	36	EFF1	90.8	91	0.87	20	<b>1LE1001-1DA2Q-QQQQ</b>		67
15	17.3	160 M	2955	48	EFF1	91.4	91.5	0.88	27	<b>1LE1001-1DA3Q-QQQQ</b>		75
18.5	21.3	160 L	2955	60	EFF1	92	92.5	0.88	33	<b>1LE1001-1DA4Q-QQQQ</b>		84
<b>4-pole – 1500 rpm at 50 Hz, 1800 rpm at 60 Hz</b>												
2.2	2.55	100 L	1455	14	EFF1	86.4	87	0.81	4.55	<b>1LE1001-1AB4Q-QQQQ</b>		21
3	3.45	100 L	1455	20	EFF1	87.4	88	0.82	6	<b>1LE1001-1AB5Q-QQQQ</b>		25
4	4.6	112 M	1460	26	EFF1	88.3	88.5	0.81	8.1	<b>1LE1001-1BB2Q-QQQQ</b>		29
5.5	6.3	132 S	1465	36	EFF1	89.2	89.5	0.80	11.2	<b>1LE1001-1CB0Q-QQQQ</b>		42
7.5	8.6	132 M	1465	49	EFF1	90.1	91	0.83	14.4	<b>1LE1001-1CB2Q-QQQQ</b>		49
11	12.6	160 M	1470	71	EFF1	91.2	91.8	0.85	20.5	<b>1LE1001-1DB2Q-QQQQ</b>		71
15	17.3	160 L	1475	97	EFF1	92	92.4	0.85	27.5	<b>1LE1001-1DB4Q-QQQQ</b>		83
<b>6-pole – 1000 rpm at 50 Hz, 1200 rpm at 60 Hz</b>												
1.5	1.75	100 L	970	15		84.5	84.5	0.73	3.5	<b>1LE1001-1AC4Q-QQQQ</b>		25
2.2	2.55	112 M	965	22		85	85	0.75	5	<b>1LE1001-1BC2Q-QQQQ</b>		29
3	3.45	132 S	970	30		85	85	0.74	6.9	<b>1LE1001-1CC0Q-QQQQ</b>		38
4	4.6	132 M	970	39		86	86	0.78	8.6	<b>1LE1001-1CC2Q-QQQQ</b>		43
5.5	6.3	132 M	970	54		88	88	0.77	11.8	<b>1LE1001-1CC3Q-QQQQ</b>		52
7.5	8.6	160 M	975	73		89	89	0.77	15.8	<b>1LE1001-1DC2Q-QQQQ</b>		77
11	12.6	160 L	975	108		89.5	89	0.80	22	<b>1LE1001-1DC4Q-QQQQ</b>		93
<b>8-pole – 750 rpm at 50 Hz, 900 rpm at 60 Hz</b>												
0.75	0.86	100 L	725	9.9		68	65	0.58	2.75	<b>1LE1001-1AD4Q-QQQQ</b>		21
1.1	1.3	100 L	725	14		68	64.5	0.58	4.05	<b>1LE1001-1AD5Q-QQQQ</b>		25
1.5	1.75	112 M	720	20		77	75.5	0.67	4.2	<b>1LE1001-1BD2Q-QQQQ</b>		29
2.2	2.55	132 S	725	29		77.5	76.7	0.63	6.5	<b>1LE1001-1CD0Q-QQQQ</b>		41
3	3.45	132 M	730	40		84	82	0.65	7.9	<b>1LE1001-1CD2Q-QQQQ</b>		49
4	4.6	160 M	730	52		87	88	0.69	9.6	<b>1LE1001-1DD2Q-QQQQ</b>		69
5.5	6.3	160 M	735	72		87.5	89	0.69	13.2	<b>1LE1001-1DD3Q-QQQQ</b>		82
7.5	8.6	160 L	730	98		88	89	0.72	17	<b>1LE1001-1DD4Q-QQQQ</b>		94

Order No. supplements, see from Page 1/24.

# IEC Squirrel-Cage Motors

## New Generation 1LE1/1PC1

Self-ventilated energy-saving motors  
with high efficiency

### Selection and ordering data (continued)

Order No.	Locked-rotor torque	Locked-rotor current	Breakdown torque	Torque class	Moment of inertia	Noise at rated output	
	with direct starting torque	as multiple of rated current	torque			Measuring-surface sound pressure level at 50 Hz	Sound pressure level at 50 Hz
	$T_{LR}/T_{rated}$	$I_{LR}/I_{rated}$	$T_B/T_{rated}$	CL	$J$ kgm <sup>2</sup>	$L_{p(A)}$ dB(A)	$L_{WA}$ dB(A)
<b>Motor version: temperature class 155 (F), IP55 degree of protection, used acc. to temperature class 130 (B)</b>							
<b>For use according to CEMEP</b>							
<b>2-pole – 3000 rpm at 50 Hz, 3600 rpm at 60 Hz</b>							
1LE1001-1AA4Q-QQQQ	2.3	7	3.3	16	0.0044	67	79
1LE1001-1BA2Q-QQQQ	2.4	7.4	3.3	16	0.0092	69	81
1LE1001-1CA0Q-QQQQ	1.8	6.7	2.9	16	0.02012	68	80
1LE1001-1CA1Q-QQQQ	2.2	7.5	3.1	16	0.02353	68	80
1LE1001-1DA2Q-QQQQ	2.1	7.4	3.2	16	0.04471	70	82
1LE1001-1DA3Q-QQQQ	2.4	7.6	3.4	16	0.05277	70	82
1LE1001-1DA4Q-QQQQ	2.9	7.9	3.6	16	0.06085	70	82
<b>4-pole – 1500 rpm at 50 Hz, 1800 rpm at 60 Hz</b>							
1LE1001-1AB4Q-QQQQ	2.1	6.9	3.3	16	0.0086	60	72
1LE1001-1AB5Q-QQQQ	2	6.9	3.1	16	0.0109	60	72
1LE1001-1BB2Q-QQQQ	2.5	7.1	3.2	16	0.014	58	70
1LE1001-1CB0Q-QQQQ	2.3	6.9	2.9	16	0.02698	64	76
1LE1001-1CB2Q-QQQQ	2.3	6.9	2.9	16	0.03353	64	76
1LE1001-1DB2Q-QQQQ	2.2	6.7	2.8	16	0.06495	65	77
1LE1001-1DB4Q-QQQQ	2.5	7.3	3	16	0.08281	65	77
<b>6-pole – 1000 rpm at 50 Hz, 1200 rpm at 60 Hz</b>							
1LE1001-1AC4Q-QQQQ	2	6.2	2.9	16	0.0113	59	71
1LE1001-1BC2Q-QQQQ	2.1	6	3.1	16	0.0139	57	69
1LE1001-1CC0Q-QQQQ	1.6	5.6	2.6	13	0.02371	63	75
1LE1001-1CC2Q-QQQQ	1.6	5.6	2.5	13	0.02918	63	75
1LE1001-1CC3Q-QQQQ	1.9	6.1	2.8	16	0.03673	63	75
1LE1001-1DC2Q-QQQQ	1.8	6.3	2.8	16	0.0754	67	79
1LE1001-1DC4Q-QQQQ	1.7	6.2	2.7	16	0.0975	67	79
<b>8-pole – 750 rpm at 50 Hz, 900 rpm at 60 Hz</b>							
1LE1001-1AD4Q-QQQQ	1.6	4	2.8	13	0.0086	60	72
1LE1001-1AD5Q-QQQQ	1.8	4	2.8	13	0.0109	60	72
1LE1001-1BD2Q-QQQQ	1.4	4.2	2.4	13	0.014	63	75
1LE1001-1CD0Q-QQQQ	1.4	3.6	1.8	10	0.02698	63	75
1LE1001-1CD2Q-QQQQ	1.4	5	2.4	10	0.03463	63	75
1LE1001-1DD2Q-QQQQ	1.8	4.3	2	13	0.0649	63	75
1LE1001-1DD3Q-QQQQ	2.1	4.4	2.1	13	0.0828	63	75
1LE1001-1DD4Q-QQQQ	1.9	4.5	2.1	13	0.0982	63	75

# IEC Squirrel-Cage Motors

## New Generation 1LE1/1PC1

Self-ventilated energy-saving motors  
with high efficiency

### Selection and ordering data (continued)

#### Order No. supplements

Motor type	Frame size	Positions 12 and 13: Voltages (voltage codes)							
		Standard voltages				Further voltages			
		50 Hz				50 Hz			
		230 VΔ/400 VY	400 VΔ/690 VY	500 VY	500 VΔ	220 VΔ/380 VY	380 VΔ/660 VY	415 VY	415 VΔ
		<u>60 Hz</u>				<u>Rated voltage range</u>			
		460 VY	460 VΔ			(210 ... 230 VΔ/ 360 ... 400 VY) <sup>1)</sup>	(360 ... 400 VΔ/ 625 ... 695 VY) <sup>1)</sup>	(395 ... 435 VY) <sup>1)</sup>	(395 ... 435 VΔ) <sup>1)</sup>
		see "Selection and ordering data" for outputs at 60 Hz							
		<b>22</b>	<b>34</b>	<b>27</b>	<b>40</b>	<b>21</b>	<b>33</b>	<b>23</b>	<b>35</b>
1LE1001-1A...-□-□...	100 L	○	○	○	○	✓	✓	✓	✓
1LE1001-1B...-□-□...	112 M	○	○	○	○	✓	✓	✓	✓
1LE1001-1C...-□-□...	132 S/M	○	○	○	○	✓	✓	✓	✓
1LE1001-1D...-□-□...	160 M/L	○	○	○	○	✓	✓	✓	✓

○ Without additional charge  
✓ With additional charge

Order other voltages with voltage code **9** in position 12, code **0** in position 13 and the corresponding order code (see "Special versions" in the "Selection and ordering data" under "Voltages", Page 1/54).

Motor type	Frame size	Position 14: Types of construction (type letter)												
		Without flange							With flange (acc. to DIN EN 50347)					
		IM B3 <sub>2)3)</sub>	IM B6 <sub>3)</sub>	IM B7 <sub>3)</sub>	IM B8 <sub>3)</sub>	IM V6 <sub>3)</sub>	IM V5 without protective cover <sub>3)</sub>	IM V5 with protective cover <sub>3)4)5)</sub>	Flange size	IM B5 <sub>3)6)</sub>	IM V1 without protective cover <sub>3)</sub>	IM V1 with protective cover <sub>3)4)5)</sub>	IM V3 <sub>3)</sub>	IM B35
		<b>A</b>	<b>T</b>	<b>U</b>	<b>V</b>	<b>D</b>	<b>C</b>	<b>C</b>	<b>F</b>	<b>G</b>	<b>G</b>	<b>H</b>	<b>J</b>	
		Order No. supplement <b>-Z</b> with order code												
		-	-	-	-	-	-	<b>-Z H00</b>	-	-	<b>-Z H00</b>	-	-	
1LE1001-1A...-□-□...	100 L	□	□	□	□	□	□	✓	FF 215	✓	✓	✓	✓	
1LE1001-1B...-□-□...	112 M	□	□	□	□	□	□	✓	FF 215	✓	✓	✓	✓	
1LE1001-1C...-□-□...	132 S/M	□	□	□	□	□	□	✓	FF 265	✓	✓	✓	✓	
1LE1001-1D...-□-□...	160 M/L	□	□	□	□	□	□	✓	FF 300	✓	✓	✓	✓	

Motor type	Frame size	Position 14: Types of construction (type letter)											
		With standard flange (acc. to DIN EN 50347)					With standard flange (next larger standard flange acc. to DIN EN 50347)						
		Flange size	IM B14 <sub>3)7)</sub>	IM V19 <sub>3)</sub>	IM V18 without protective cover <sub>3)</sub>	IM V18 with protective cover <sub>3)4)5)</sub>	IM B34	Flange size	IM B14 <sub>3)7)</sub>	IM V19 <sub>3)</sub>	IM V18 without protective cover <sub>3)</sub>	IM V18 with protective cover <sub>3)4)5)</sub>	IM B34
			<b>K</b>	<b>L</b>	<b>M</b>	<b>M</b>	<b>N</b>		<b>K</b>	<b>L</b>	<b>M</b>	<b>M</b>	<b>N</b>
		Order No. supplement <b>-Z</b> with order code											
			-	-	-	<b>-Z H00</b>	-	<b>-Z</b>	<b>-Z</b>	<b>-Z</b>	<b>-Z</b>	<b>-Z H00</b>	<b>-Z</b>
			<b>P01</b>	<b>P01</b>	<b>P01</b>	<b>P01</b>	<b>P01</b>	<b>P01</b>	<b>P01</b>	<b>P01</b>	<b>P01</b>	<b>P01</b>	<b>P01</b>
1LE1001-1A...-□-□...	100 L	FT 130	✓	✓	✓	✓	✓	FT 165	✓	✓	✓	✓	✓
1LE1001-1B...-□-□...	112 M	FT 130	✓	✓	✓	✓	✓	FT 165	✓	✓	✓	✓	✓
1LE1001-1C...-□-□...	132 S/M	FT 165	✓	✓	✓	✓	✓	FT 215	✓	✓	✓	✓	✓
1LE1001-1D...-□-□...	160 M/L	FT 215	✓	✓	✓	✓	✓	-	-	-	-	-	-

□ Standard version  
✓ With additional charge

<sup>1)</sup> A rated voltage range is also specified on the rating plate.

<sup>2)</sup> The types of construction IM B6/7/8, IM V6 and IM V5 without protective cover/with protective cover are also possible as long as no condensation drainage holes (order code **H03**) and no stamping of these types of construction on the rating plate are required. As standard, the type of construction IM B3 is then stamped on the rating plate. With type of construction IM V5 with protective cover, the protective cover has to be additionally ordered with order code **H00**. The protective cover is not stamped on the rating plate.

<sup>3)</sup> The type of construction is stamped on the rating plate. When ordering with condensation drainage holes (order code **H03**), it is absolutely necessary to specify the type of construction for the exact position of the condensation drainage holes during manufacture.

<sup>4)</sup> Option second shaft extension (order code **L05**) not possible.

<sup>5)</sup> In combination with an encoder, it is not necessary to order the protective cover (order code **H00**), as this is delivered as a protection for the encoder as standard. In this case, the protective cover is standard design (without additional charge).

<sup>6)</sup> The types of construction IM V3 and IM V1 without protective cover/with protective cover are also possible as long as no condensation drainage holes (order code **H03**) and no stamping of these types of construction on the rating plate are required. As standard, the type of construction IM B5 is then stamped on the rating plate. With type of construction IM V1 with protective cover, the protective cover has to be additionally ordered with order code **H00**. The protective cover is not stamped on the rating plate.

<sup>7)</sup> The types of construction IM V19 and IM V18 without protective cover/with protective cover are also possible as long as no condensation drainage holes (order code **H03**) and no stamping of these types of construction on the rating plate are required. As standard, the type of construction IM B14 is then stamped on the rating plate. With type of construction IM V18 with protective cover, the protective cover has to be additionally ordered with order code **H00**. The protective cover is not stamped on the rating plate.

# IEC Squirrel-Cage Motors

## New Generation 1LE1/1PC1

Self-ventilated energy-saving motors  
with high efficiency

### Selection and ordering data (continued)

Motor type	Frame size	Position 15: Motor protection (motor protection letter)					
		Without motor protection	Motor protection with PTC thermistors with 3 embedded temperature sensors for tripping <sup>1)</sup>	Motor protection with PTC thermistors with 6 embedded temperature sensors for alarm and tripping <sup>1)</sup>	Motor temperature detection with embedded temperature sensor KTY 84-130 <sup>1)</sup>	NTC thermistors for tripping	Temperature detectors for tripping <sup>1)</sup>
Order code		A	B	C	F	Z Q2A	Z Q3A
1LE1001-1A...-...□	100 L	□	✓	✓	✓	✓	✓
1LE1001-1B...-...□	112 M	□	✓	✓	✓	✓	✓
1LE1001-1C...-...□	132 S/M	□	✓	✓	✓	✓	✓
1LE1001-1D...-...□	160 M/L	□	✓	✓	✓	✓	✓

- Standard version  
✓ With additional charge

Motor type	Frame size	Position 16: Connection box (connection box code)			
		Connection box top <sup>2)</sup>	Connection box on RHS <sup>3)</sup>	Connection box on LHS <sup>3)</sup>	Connection box bottom <sup>3)</sup>
		4	5	6	7
1LE1001-1A...-...□	100 L	□	✓	✓	✓
1LE1001-1B...-...□	112 M	□	✓	✓	✓
1LE1001-1C...-...□	132 S/M	□	✓	✓	✓
1LE1001-1D...-...□	160 M/L	□	✓	✓	✓

- Standard version  
✓ With additional charge

<sup>1)</sup> Evaluation with appropriate tripping unit (see Catalog LV 1) is recommended.  
<sup>2)</sup> With type of construction, cast feet as standard. Screwed-on feet are available with order code **H01**, see "Special versions".  
<sup>3)</sup> With type of construction, screwed-on feet as standard.

# IEC Squirrel-Cage Motors

## New Generation 1LE1/1PC1

Self-ventilated energy-saving motors  
with high efficiency

### Selection and ordering data (continued)

Rated output at		Frame size	Operating values at rated output						Order No.	Price	Weight
50 Hz	60 Hz		Rated speed at 60 Hz	Rated torque at 60 Hz	EPACT with CC-No. CCxxx	Nominal efficiency at 60 Hz	Power factor at 60 Hz 4/4-load	Rated current at 460 V, 60 Hz			
$P_{\text{rated}}$ kW	$P_{\text{rated}}$ HP	FS	$n_{\text{rated}}$ rpm	$T_{\text{rated}}$ Nm		$\eta_{\text{rated}}$ %	$\cos\phi_{\text{rated}}$	$I_{\text{rated}}$ A	For Order No. supplements for voltage, type of construction, motor protection and connection box, see from Page 1/28	IM B3 type of construction	IM B3 type of construction approx. $m$ kg
<b>Motor version: temperature class 155 (F), IP55 degree of protection, used acc. to temperature class 130 (B)</b>											
<b>For use in the North American market according to EPACT</b>											
<b>2-pole – 3600 rpm at 60 Hz</b>											
3	4	100 L	3520	8.1	A. S.	86.5	0.83	5.2	<b>1LE1001-1AA4Q-Q000Q</b>		21
4	5	112 M	3565	9.9	A. S.	87.5	0.84	6.3	<b>1LE1001-1BA2Q-Q000Q</b>		27
5.5	7.5	132 S	3560	15	A. S.	89.5	0.86	9	<b>1LE1001-1CA0Q-Q000Q</b>		39
7.5	10	132 S	3560	20	A. S.	90.2	0.87	12	<b>1LE1001-1CA1Q-Q000Q</b>		43
11	15	160 M	3560	30	A. S.	90.2	0.86	17.8	<b>1LE1001-1DA2Q-Q000Q</b>		67
15	20	160 M	3565	40	A. S.	91	0.87	24	<b>1LE1001-1DA3Q-Q000Q</b>		75
18.5	25	160 L	3565	50	A. S.	91.7	0.87	29	<b>1LE1001-1DA4Q-Q000Q</b>		84
<b>4-pole – 1800 rpm at 60 Hz</b>											
2.2	3	100 L	1760	12	A. S.	87.5	0.78	4.05	<b>1LE1001-1AB4Q-Q000Q</b>		21
3	4	100 L	1765	16	A. S.	87.5	0.79	5.4	<b>1LE1001-1AB5Q-Q000Q</b>		25
4	5	112 M	1770	20	A. S.	88.5	0.77	6.8	<b>1LE1001-1BB2Q-Q000Q</b>		29
5.5	7.5	132 S	1770	30	A. S.	89.5	0.78	9.9	<b>1LE1001-1CB0Q-Q000Q</b>		42
7.5	10	132 M	1770	40	A. S.	89.5	0.82	12.8	<b>1LE1001-1CB2Q-Q000Q</b>		49
11	15	160 M	1775	59	A. S.	91	0.84	18.1	<b>1LE1001-1DB2Q-Q000Q</b>		71
15	20	160 L	1780	80	A. S.	91.7	0.84	24.5	<b>1LE1001-1DB4Q-Q000Q</b>		83
<b>6-pole – 1200 rpm at 60 Hz</b>											
1.5	2	100 L	1175	12	A. S.	86.5	0.69	3.15	<b>1LE1001-1AC4Q-Q000Q</b>		25
2.2	3	112 M	1170	18	A. S.	87.5	0.73	4.3	<b>1LE1001-1BC2Q-Q000Q</b>		29
3	4	132 S	1175	24	A. S.	87.5	0.7	6.1	<b>1LE1001-1CC0Q-Q000Q</b>		38
4	5	132 M	1180	30	A. S.	87.5	0.73	7.3	<b>1LE1001-1CC2Q-Q000Q</b>		43
5.5	7.5	132 M	1175	45	A. S.	89.5	0.74	10.4	<b>1LE1001-1CC3Q-Q000Q</b>		52
7.5	10	160 M	1180	61	A. S.	89.5	0.74	14.2	<b>1LE1001-1DC2Q-Q000Q</b>		77
11	15	160 L	1180	89	A. S.	90.2	0.78	19.6	<b>1LE1001-1DC4Q-Q000Q</b>		93

A. S. Available soon

Order No. supplements, see from Page 1/28.



# IEC Squirrel-Cage Motors

## New Generation 1LE1/1PC1

Self-ventilated energy-saving motors  
with high efficiency

### Selection and ordering data (continued)

Order No.	Locked-rotor torque with direct starting torque	Locked-rotor current as multiple of rated current	Breaddown torque torque	Torque class	Moment of inertia	Noise at rated output	
	$T_{LR}/T_{rated}$	$I_{LR}/I_{rated}$	$T_B/T_{rated}$	CL	$J$ kgm <sup>2</sup>	Measuring-surface sound pressure level at 60 Hz $L_{p(A)}$	Sound pressure level at 60 Hz $L_{WA}$
<b>Motor version: temperature class 155 (F), IP55 degree of protection, used acc. to temperature class 130 (B)</b>							
<b>For use in the North American market according to EPACT</b>							
<b>2-pole – 3600 rpm at 60 Hz</b>							
1LE1001-1AA4□-□□□□	2.56	7.3	3.83	16	0.0044	71	83
1LE1001-1BA2□-□□□□	2.9	7.8	4	16	0.0092	73	85
1LE1001-1CA0□-□□□□	2.04	6.9	3.3	16	0.02012	72	84
1LE1001-1CA1□-□□□□	2.3	7.4	3.56	16	0.02353	72	84
1LE1001-1DA2□-□□□□	2.38	7.4	3.63	16	0.04471	77	89
1LE1001-1DA3□-□□□□	2.76	7.6	3.91	16	0.05277	77	89
1LE1001-1DA4□-□□□□	3.31	7.9	4.1	16	0.06085	77	89
<b>4-pole – 1800 rpm at 60 Hz</b>							
1LE1001-1AB4□-□□□□	2.45	7.3	3.85	16	0.0086	62	74
1LE1001-1AB5□-□□□□	2.38	7.5	3.68	16	0.0109	62	74
1LE1001-1BB2□-□□□□	3	7.5	4	16	0.014	62	74
1LE1001-1CB0□-□□□□	2.61	7.3	3.29	16	0.02698	68	80
1LE1001-1CB2□-□□□□	2.7	7.1	3.407	16	0.03353	68	80
1LE1001-1DB2□-□□□□	2.65	7	3.22	16	0.06495	69	81
1LE1001-1DB4□-□□□□	2.79	7.7	3.37	16	0.08281	69	81
<b>6-pole – 1200 rpm at 60 Hz</b>							
1LE1001-1AC4□-□□□□	2.33	6.4	3.38	16	0.0113	62	74
1LE1001-1BC2□-□□□□	2.3	6.5	3.4	16	0.0139	60	72
1LE1001-1CC0□-□□□□	1.75	5.8	3.03	13	0.02371	67	79
1LE1001-1CC2□-□□□□	2.08	5.8	3.166	13	0.02918	67	79
1LE1001-1CC3□-□□□□	2.04	6.3	3.17	16	0.03673	67	79
1LE1001-1DC2□-□□□□	1.95	6.3	3.213	16	0.0754	70	82
1LE1001-1DC4□-□□□□	1.834	6.2	2.98	16	0.0975	70	82

# IEC Squirrel-Cage Motors

## New Generation 1LE1/1PC1

Self-ventilated energy-saving motors  
with high efficiency

### Selection and ordering data (continued)

#### Order No. supplements

Motor type	Frame size	Positions 12 and 13: Voltages (voltage codes)	
		Standard voltages	
		60 Hz	
		460 VY	460 VΔ
		see "Selection and ordering data" for outputs at 60 Hz	
		<b>22</b>	<b>34</b>
1LE1001-1A...-□-□...	100 L	○	○
1LE1001-1B...-□-□...	112 M	○	○
1LE1001-1C...-□-□...	132 S/M	○	○
1LE1001-1D...-□-□...	160 M/L	○	○

- Without additional charge  
✓ With additional charge

Order other voltages with voltage code **9** in position 12, code **0** in position 13 and the corresponding order code (see "Special versions" in the "Selection and ordering data" under "Voltages", Page 1/54).

Motor type	Frame size	Position 14: Type of construction (type letter)												
		With flange						With flange (acc. to DIN EN 50347)						
		IM B3 1) 2)	IM B6 2)	IM B7 2)	IM B8 2)	IM V6 2)	IM V5 without protective cover 2)	IM V5 with protective cover 2) 3) 4)	Flange size	IM B5 2) 5)	IM V1 without protective cover 2)	IM V1 with protective cover 2) 3) 4)	IM V3 2)	IM B35
		<b>A</b>	<b>T</b>	<b>U</b>	<b>V</b>	<b>D</b>	<b>C</b>	<b>C</b>		<b>F</b>	<b>G</b>	<b>G</b>	<b>H</b>	<b>J</b>
		Order No. supplement <b>-Z</b> with order code												
		-	-	-	-	-	-	<b>-Z H00</b>		-	-	<b>-Z H00</b>	-	-
1LE1001-1A...-□-□...	100 L	□	□	□	□	□	□	✓	<b>FF 215</b>	✓	✓	✓	✓	✓
1LE1001-1B...-□-□...	112 M	□	□	□	□	□	□	✓	<b>FF 215</b>	✓	✓	✓	✓	✓
1LE1001-1C...-□-□...	132 S/M	□	□	□	□	□	□	✓	<b>FF 265</b>	✓	✓	✓	✓	✓
1LE1001-1D...-□-□...	160 M/L	□	□	□	□	□	□	✓	<b>FF 300</b>	✓	✓	✓	✓	✓

Motor type	Frame size	Position 14: Type of construction (type letter)											
		With standard flange (acc. to DIN EN 50347)					With standard flange (next larger standard flange acc. to DIN EN 50347)						
		Flange size	IM B14 2) 6)	IM V19 2)	IM V18 without protective cover 2)	IM V18 with pro- tective cover 2) 3) 4)	IM B34	Flange size	IM B14 2) 6)	IM V19 2)	IM V18 without protective cover 2)	IM V18 with protective cover 2) 3) 4)	IM B34
			<b>K</b>	<b>L</b>	<b>M</b>	<b>M</b>	<b>N</b>		<b>K</b>	<b>L</b>	<b>M</b>	<b>M</b>	<b>N</b>
		Order No. supplement <b>-Z</b> with order code											
			-	-	-	<b>-Z H00</b>	-		<b>-Z</b>	<b>-Z</b>	<b>-Z</b>	<b>-Z H00</b>	<b>-Z</b>
			<b>P01</b>	<b>P01</b>	<b>P01</b>	<b>P01</b>	<b>P01</b>		<b>P01</b>	<b>P01</b>	<b>P01</b>	<b>P01</b>	<b>P01</b>
1LE1001-1A...-□-□...	100 L	<b>FT 130</b>	✓	✓	✓	✓	✓	<b>FT 165</b>	✓	✓	✓	✓	✓
1LE1001-1B...-□-□...	112 M	<b>FT 130</b>	✓	✓	✓	✓	✓	<b>FT 165</b>	✓	✓	✓	✓	✓
1LE1001-1C...-□-□...	132 S/M	<b>FT 165</b>	✓	✓	✓	✓	✓	<b>FT 215</b>	✓	✓	✓	✓	✓
1LE1001-1D...-□-□...	160 M/L	<b>FT 215</b>	✓	✓	✓	✓	✓	-	-	-	-	-	-

- Standard version  
✓ With additional charge

- The types of construction IM B6/7/8, IM V6 and IM V5 without protective cover/with protective cover are also possible as long as no condensation drainage holes (order code **H03**) and no stamping of these types of construction on the rating plate are required. As standard, the type of construction IM B3 is then stamped on the rating plate. With type of construction IM V5 with protective cover, the protective cover has to be additionally ordered with order code **H00**. The protective cover is not stamped on the rating plate.
- The type of construction is stamped on the rating plate. When ordering with condensation drainage holes (order code **H03**), it is absolutely necessary to specify the type of construction for the exact position of the condensation drainage holes during manufacture.
- Option second shaft extension (order code **L05**) not possible
- In combination with an encoder, it is not necessary to order the protective cover (order code **H00**), as this is delivered as a protection for the encoder as standard. In this case, the protective cover is standard design (without additional charge).

- The types of construction IM V3 and IM V1 without protective cover/with protective cover are also possible as long as no condensation drainage holes (order code **H03**) and no stamping of these types of construction on the rating plate are required. As standard, the type of construction IM B5 is then stamped on the rating plate. With type of construction IM V1 with protective cover, the protective cover has to be additionally ordered with order code **H00**. The protective cover is not stamped on the rating plate.
- The types of construction IM V19 and IM V18 without protective cover/with protective cover are also possible as long as no condensation drainage holes (order code **H03**) and no stamping of these types of construction on the rating plate are required. As standard, the type of construction IM B14 is then stamped on the rating plate. With type of construction IM V18 with protective cover, the protective cover has to be additionally ordered with order code **H00**. The protective cover is not stamped on the rating plate.

# IEC Squirrel-Cage Motors

## New Generation 1LE1/1PC1

Self-ventilated energy-saving motors  
with high efficiency

### Selection and ordering data (continued)

Motor type	Frame size	Position 15: Motor protection (motor protection letter)					
		Without motor protection	Motor protection with PTC thermistors with 3 embedded temperature sensors for tripping <sup>1)</sup>	Motor protection with PTC thermistors with 6 embedded temperature sensors for alarm and tripping <sup>1)</sup>	Motor temperature detection with embedded temperature sensor KTY 84-130 <sup>1)</sup>	NTC thermistors for tripping	Temperature detectors for tripping <sup>1)</sup>
Order code		A	B	C	F	Z Q2A	Z Q3A
1LE1001-1A...-□	100 L	□	✓	✓	✓	✓	✓
1LE1001-1B...-□	112 M	□	✓	✓	✓	✓	✓
1LE1001-1C...-□	132 S/M	□	✓	✓	✓	✓	✓
1LE1001-1D...-□	160 M/L	□	✓	✓	✓	✓	✓

- Standard version  
 ✓ With additional charge

Motor type	Frame size	Position 16: Connection box (connection box code)			
		Connection box top <sup>2)</sup>	Connection box on RHS <sup>3)</sup>	Connection box on LHS <sup>3)</sup>	Connection box bottom <sup>3)</sup>
		4	5	6	7
1LE1001-1A...-□	100 L	□	✓	✓	✓
1LE1001-1B...-□	112 M	□	✓	✓	✓
1LE1001-1C...-□	132 S/M	□	✓	✓	✓
1LE1001-1D...-□	160 M/L	□	✓	✓	✓

- Standard version  
 ✓ With additional charge

<sup>1)</sup> Evaluation with appropriate tripping unit (see Catalog LV 1) is recommended.  
<sup>2)</sup> With type of construction, cast feet as standard. Screwed-on feet are available with order code **H01**, see "Special versions".  
<sup>3)</sup> With type of construction, screwed-on feet as standard.

# IEC Squirrel-Cage Motors

## New Generation 1LE1/1PC1

Self-ventilated motors with increased output and improved efficiency

### Selection and ordering data

Rated output at		Frame size	Operating values at rated output								Order No.	Price	Weight
50 Hz	60 Hz		Rated speed at 50 Hz	Rated torque at 50 Hz	Efficiency Class according to CEMEP	Efficiency at 50 Hz 4/4-load	Efficiency at 50 Hz 3/4-load	Power factor at 50 Hz 4/4-load	Rated current at 400 V, 50 Hz				
$P_{\text{rated}}$ kW	$P_{\text{rated}}$ kW	FS	$n_{\text{rated}}$ rpm	$T_{\text{rated}}$ Nm		$\eta_{\text{rated}}$ %	$\eta_{\text{rated}}$ %	$\cos\varphi_{\text{rated}}$	$I_{\text{rated}}$ A	For Order No. supplements for voltage, type of construction, motor protection and connection box, see table from Page 1/32.	IM B3 type of construction	IM B3 type of construction approx. $m$ kg	
<b>Motor version: temperature class 155 (F), IP55 degree of protection, with increased output, used acc. to temperature class 130 (B) <sup>1)</sup></b>													
<b>2-pole – 3000 rpm at 50 Hz, 3600 rpm at 60 Hz</b>													
4	4.6	100 L	2850	13.3	EFF2	85.6	86.2	0.85	7.9	<b>1LE1002-1AA6Q-QQQQ</b>		25	
5.5	6.3	112 M	2935	18	EFF2	87	85.5	0.86	10.6	<b>1LE1002-1BA6Q-QQQQ</b>		31	
11	12.6	132 M	2920	36	EFF2	90	90.7	0.90	19.6	<b>1LE1002-1CA6Q-QQQQ</b>		53	
22	24.5	160 L	2930	72	EFF2	91.6	91.4	0.88	39.5	<b>1LE1002-1DA6Q-QQQQ</b>		85	
<b>4-pole – 1500 rpm at 50 Hz, 1800 rpm at 60 Hz</b>													
4	4.6	100 L	1430	26.8	EFF2	84.2	85.1	0.81	8.5	<b>1LE1002-1AB6Q-QQQQ</b>		27	
5.5	6.3	112 M	1420	37	EFF2	85.7	86.5	0.81	11	<b>1LE1002-1BB6Q-QQQQ</b>		33	
11	12.6	132 M	1450	72	EFF2	88.8	89.3	0.84	21.5	<b>1LE1002-1CB6Q-QQQQ</b>		58	
18.5	21.3	160 L	1460	121	EFF2	90	90.2	0.85	35	<b>1LE1002-1DB6Q-QQQQ</b>		85	
<b>6-pole – 1000 rpm at 50 Hz, 1200 rpm at 60 Hz</b>													
2.2	2.55	100 L	930	22.5		76	77.3	0.78	5.3	<b>1LE1002-1AC6Q-QQQQ</b>		24	
3	3.45	112 M	945	30		79	78.2	0.72	7.6	<b>1LE1002-1BC6Q-QQQQ</b>		32	
7.5	8.6	132 M	950	75		85.5	85.7	0.74	17.2	<b>1LE1002-1CC6Q-QQQQ</b>		54	
15	17.3	160 L	965	148		88	88	0.75	33	<b>1LE1002-1DC6Q-QQQQ</b>		109	

Order No. supplements, see from Page 1/32.

<sup>1)</sup> For Order No. 1LE1002-1CC6Q-QQQQ use acc. to temperature class 155 (F).

# IEC Squirrel-Cage Motors

## New Generation 1LE1/1PC1

Self-ventilated motors with increased output  
and improved efficiency

### Selection and ordering data (continued)

Order No.	Locked-rotor torque	Locked-rotor current	Breakdown torque	Torque class	Moment of inertia	Noise at rated output	
	with direct starting torque	as multiple of rated current	torque			Measuring-surface sound pressure level at 50 Hz	Sound pressure level at 50 Hz
	$T_{LR}/T_{rated}$	$I_{LR}/I_{rated}$	$T_B/T_{rated}$	CL	$J$ kgm <sup>2</sup>	$L_{pFA}$ dB(A)	$L_{WA}$ dB(A)
<b>Motor version: temperature class 155 (F), IP55 degree of protection, with increased output, used acc. to temperature class 130 (B)</b>							
<b>2-pole – 3000 rpm at 50 Hz, 3600 rpm at 60 Hz</b>							
<b>1LE1002-1AA6□-□□□□</b>	4.5	7	4.1	16	0.0044	67	79
<b>1LE1002-1BA6□-□□□□</b>	2.9	7.5	3.8	16	0.0085	69	81
<b>1LE1002-1CA6□-□□□□</b>	2.8	7.5	3.7	16	0.02233	68	80
<b>1LE1002-1DA6□-□□□□</b>	2.6	7.5	3.4	16	0.04913	70	82
<b>4-pole – 1500 rpm at 50 Hz, 1800 rpm at 60 Hz</b>							
<b>1LE1002-1AB6□-□□□□</b>	2.9	5.8	3.1	16	0.01	60	72
<b>1LE1002-1BB6□-□□□□</b>	3	5.8	3.1	16	0.0124	58	70
<b>1LE1002-1CB6□-□□□□</b>	2.5	7.2	3	16	0.03259	64	76
<b>1LE1002-1DB6□-□□□□</b>	2.7	7.2	3.2	16	0.06843	65	77
<b>6-pole – 1000 rpm at 50 Hz, 1200 rpm at 60 Hz</b>							
<b>1LE1002-1AC6□-□□□□</b>	2	4	2.2	16	0.0084	59	71
<b>1LE1002-1BC6□-□□□□</b>	2.9	4.6	3	16	0.0128	57	69
<b>1LE1002-1CC6□-□□□□</b>	2.4	5.3	3	16	0.032	63	75
<b>1LE1002-1DC6□-□□□□</b>	2.9	6	3.4	16	0.0936	67	79

# IEC Squirrel-Cage Motors

## New Generation 1LE1/1PC1

Self-ventilated motors with increased output and improved efficiency

### Selection and ordering data (continued)

#### Order No. supplements

Motor type	Frame size	Positions 12 and 13: Voltages (voltage codes)							
		Standard voltages				Further voltages			
		50 Hz				50 Hz			
		230 VΔ/400 VY	400 VΔ/690 VY	500 VY	500 VΔ	220 VΔ/380 VY	380 VΔ/660 VY	415 VY	415 VΔ
		<u>60 Hz</u>				<u>Rated voltage range</u>			
		460 VY	460 VΔ			(210 ... 230 VΔ/ 360 ... 400 VY) <sup>1)</sup>	(360 ... 400 VΔ/ 625 ... 695 VY) <sup>1)</sup>	(395 ... 435 VY) <sup>1)</sup>	(395 ... 435 VΔ) <sup>1)</sup>
		see "Selection and ordering data" for outputs at 60 Hz							
		<b>22</b>	<b>34</b>	<b>27</b>	<b>40</b>	<b>21</b>	<b>33</b>	<b>23</b>	<b>35</b>
1LE1002-1A...-□-□...	100 L	○	○	○	○	✓	✓	✓	✓
1LE1002-1B...-□-□...	112 M	○	○	○	○	✓	✓	✓	✓
1LE1002-1C...-□-□...	132 M	○	○	○	○	✓	✓	✓	✓
1LE1002-1D...-□-□...	160 L	○	○	○	○	✓	✓	✓	✓

- Without additional charge  
✓ With additional charge

Order other voltages with voltage code **9** in position 12, code **0** in position 13 and the corresponding order code (see "Special versions" in the "Selection and ordering data" under "Voltages", Page 1/54).

Motor type	Frame size	Position 14: Types of construction (type letter)												
		Without flange						With flange (acc. to DIN EN 50347)						
		IM B3 <sub>2)3)</sub>	IM B6 <sub>3)</sub>	IM B7 <sub>3)</sub>	IM B8 <sub>3)</sub>	IM V6 <sub>3)</sub>	IM V5 without protective cover <sub>3)</sub>	IM V5 with protective cover <sub>3)4)5)</sub>	Flange size	IM B5 <sub>3)6)</sub>	IM V1 without protective cover <sub>3)</sub>	IM V1 with protective cover <sub>3)4)5)</sub>	IM V3 <sub>3)</sub>	IM B35
		<b>A</b>	<b>T</b>	<b>U</b>	<b>V</b>	<b>D</b>	<b>C</b>	<b>C</b>	<b>F</b>	<b>G</b>	<b>G</b>	<b>H</b>	<b>J</b>	
		Order No. supplement <b>-Z</b> with order code												
		-	-	-	-	-	-	<b>-Z H00</b>	-	-	<b>-Z H00</b>	-	-	
1LE1002-1A...-□-□...	100 L	□	□	□	□	□	□	✓	<b>FF 215</b>	✓	✓	✓	✓	✓
1LE1002-1B...-□-□...	112 M	□	□	□	□	□	□	✓	<b>FF 215</b>	✓	✓	✓	✓	✓
1LE1002-1C...-□-□...	132 M	□	□	□	□	□	□	✓	<b>FF 265</b>	✓	✓	✓	✓	✓
1LE1002-1D...-□-□...	160 L	□	□	□	□	□	□	✓	<b>FF 300</b>	✓	✓	✓	✓	✓

Motor type	Frame size	Position 14: Types of construction (type letter)												
		With standard flange (acc. to DIN EN 50347)					With standard flange (next larger standard flange acc. to DIN EN 50347)							
		Flange size	IM B14 <sub>3)7)</sub>	IM V19 <sub>3)</sub>	IM V18 without protective cover <sub>3)</sub>	IM V18 with protective cover <sub>3)4)5)</sub>	IM B34	Flange size	IM B14 <sub>3)7)</sub>	IM V19 <sub>3)</sub>	IM V18 without protective cover <sub>3)</sub>	IM V18 with protective cover <sub>3)4)5)</sub>	IM B34	
			<b>K</b>	<b>L</b>	<b>M</b>	<b>M</b>	<b>N</b>		<b>K</b>	<b>L</b>	<b>M</b>	<b>M</b>	<b>N</b>	
		Order No. supplement <b>-Z</b> with order code												
			-	-	-	<b>-Z H00</b>	-	<b>-Z</b>	<b>-Z</b>	<b>-Z</b>	<b>-Z</b>	<b>-Z</b>	<b>-Z</b>	
			<b>P01</b>	<b>P01</b>	<b>P01</b>	<b>P01</b>	<b>P01</b>	<b>P01</b>	<b>P01</b>	<b>P01</b>	<b>P01</b>	<b>P01</b>	<b>P01</b>	
1LE1002-1A...-□-□...	100 L	<b>FT 130</b>	✓	✓	✓	✓	✓	<b>FT 165</b>	✓	✓	✓	✓	✓	✓
1LE1002-1B...-□-□...	112 M	<b>FT 130</b>	✓	✓	✓	✓	✓	<b>FT 165</b>	✓	✓	✓	✓	✓	✓
1LE1002-1C...-□-□...	132 S/M	<b>FT 165</b>	✓	✓	✓	✓	✓	<b>FT 215</b>	✓	✓	✓	✓	✓	✓
1LE1002-1D...-□-□...	160 M/L	<b>FT 215</b>	✓	✓	✓	✓	✓	-	-	-	-	-	-	-

- Standard version  
✓ With additional charge

- A rated voltage range is also specified on the rating plate.
- The types of construction IM B6/7/8, IM V6 and IM V5 without protective cover/with protective cover are also possible as long as no condensation drainage holes (order code **H03**) and no stamping of these types of construction on the rating plate are required. As standard, the type of construction IM B3 is then stamped on the rating plate. With type of construction IM V5 with protective cover, the protective cover has to be additionally ordered with order code **H00**. The protective cover is not stamped on the rating plate.
- The type of construction is stamped on the rating plate. When ordering with condensation drainage holes (order code **H03**), it is absolutely necessary to specify the type of construction for the exact position of the condensation drainage holes during manufacture.
- Option second shaft extension (order code **L05**) not possible.

- In combination with an encoder, it is not necessary to order the protective cover (order code **H00**), as this is delivered as a protection for the encoder as standard. In this case, the protective cover is standard design (without additional charge).
- The types of construction IM V3 and IM V1 without protective cover/with protective cover are also possible as long as no condensation drainage holes (order code **H03**) and no stamping of these types of construction on the rating plate are required. As standard, the type of construction IM B5 is then stamped on the rating plate. With type of construction IM V1 with protective cover, the protective cover has to be additionally ordered with order code **H00**. The protective cover is not stamped on the rating plate.
- The types of construction IM V19 and IM V18 without protective cover/with protective cover are also possible as long as no condensation drainage holes (order code **H03**) and no stamping of these types of construction on the rating plate are required. As standard, the type of construction IM B14 is then stamped on the rating plate. With type of construction IM V18 with protective cover, the protective cover has to be additionally ordered with order code **H00**. The protective cover is not stamped on the rating plate.

# IEC Squirrel-Cage Motors

## New Generation 1LE1/1PC1

Self-ventilated motors with increased output  
and improved efficiency

### Selection and ordering data (continued)

Motor type	Frame size	Position 15: Motor protection (motor protection letter)					
		Without motor protection	Motor protection with PTC thermistors with 3 embedded temperature sensors for tripping <sup>1)</sup>	Motor protection with PTC thermistors with 6 embedded temperature sensors for alarm and tripping <sup>1)</sup>	Motor temperature detection with embedded temperature sensor KTY 84-130 <sup>1)</sup>	NTC thermistors for tripping	Temperature detectors for tripping <sup>1)</sup>
Order code		A	B	C	F	Z Q2A	Z Q3A
1LE1002-1A...-...□	100 L	□	✓	✓	✓	✓	✓
1LE1002-1B...-...□	112 M	□	✓	✓	✓	✓	✓
1LE1002-1C...-...□	132 M	□	✓	✓	✓	✓	✓
1LE1002-1D...-...□	160 L	□	✓	✓	✓	✓	✓

- Standard version  
✓ With additional charge

Motor type	Frame size	Position 16: Connection box (connection box code)			
		Connection box top <sup>2)</sup>	Connection box on RHS <sup>2)</sup>	Connection box on LHS <sup>2)</sup>	Connection box bottom <sup>2)</sup>
		4	5	6	7
1LE1002-1A...-...□	100 L	□	✓	✓	✓
1LE1002-1B...-...□	112 M	□	✓	✓	✓
1LE1002-1C...-...□	132 M	□	✓	✓	✓
1LE1002-1D...-...□	160 L	□	✓	✓	✓

- Standard version  
✓ With additional charge

<sup>1)</sup> Evaluation with appropriate tripping unit (see Catalog LV 1) is recommended.

<sup>2)</sup> With type of construction, screwed-on feet as standard.

# IEC Squirrel-Cage Motors

## New Generation 1LE1/1PC1

Self-ventilated motors with increased output and high efficiency

### Selection and ordering data

Rated output at		Frame size	Operating values at rated output							Order No.	Price	Weight
50 Hz	60 Hz		Rated speed at 50 Hz	Rated torque at 50 Hz	Efficiency Class according to CEMEP	Efficiency at 50 Hz 4/4-load	Efficiency at 50 Hz 3/4-load	Power factor at 50 Hz 4/4-load	Rated current at 400 V, 50 Hz			
$P_{\text{rated}}$ kW	$P_{\text{rated}}$ kW	FS	$n_{\text{rated}}$ rpm	$T_{\text{rated}}$ Nm		$\eta_{\text{rated}}$ %	$\eta_{\text{rated}}$ %	$\cos\varphi_{\text{rated}}$	$I_{\text{rated}}$ A	For Order No. supplements for voltage, type of construction, motor protection and connection box, see table from Page 1/36.	IM B3 type of construction	IM B3 type of construction approx. $m$ kg
<b>Motor version: temperature class 155 (F), IP55 degree of protection, with increased output, used acc. to temperature class 130 (B)</b>												
<b>2-pole – 3000 rpm at 50 Hz, 3600 rpm at 60 Hz</b>												
4	4.6	100 L	2905	13	EFF1	88	89	0.86	7.6	<b>1LE1001-1AA6Q-QQQQ</b>		26
5.5	6.3	112 M	2950	18	EFF1	89	88.5	0.89	10	<b>1LE1001-1BA6Q-QQQQ</b>		34
11	12.6	132 M	2955	36	EFF1	91.5	92.5	0.89	19.4	<b>1LE1001-1CA6Q-QQQQ</b>		57
22	25.3	160 L	2955	71	EFF1	92.8	93.5	0.89	38.5	<b>1LE1001-1DA6Q-QQQQ</b>		94
<b>4-pole – 1500 rpm at 50 Hz, 1800 rpm at 60 Hz</b>												
4	4.6	100 L	1460	26	EFF1	88.3	88.3	0.8	8.2	<b>1LE1001-1AB6Q-QQQQ</b>		30
5.5	6.3	112 M	1460	36	EFF1	89.2	89.2	0.81	11	<b>1LE1001-1BB6Q-QQQQ</b>		34
11	12.6	132 M	1465	72	EFF1	91	91.0	0.84	21	<b>1LE1001-1CB6Q-QQQQ</b>		64
18.5	21.3	160 L	1475	120	EFF1	92.4	92.4	0.85	34	<b>1LE1001-1DB6Q-QQQQ</b>		100
<b>6-pole – 1000 rpm at 50 Hz, 1200 rpm at 60 Hz</b>												
2.2	2.55	100 L	965	22		84.5	85.6	0.76	4.95	<b>1LE1001-1AC6Q-QQQQ</b>		30
3	3.45	112 M	960	30		84.5	84.7	0.79	6.5	<b>1LE1001-1BC6Q-QQQQ</b>		34
7.5	8.6	132 M	970	74		88.5	88.5	0.77	15.4	<b>1LE1001-1CC6Q-QQQQ</b>		64
15	17.3	160 L	975	147		90.6	91	0.81	29.5	<b>1LE1001-1DC6Q-QQQQ</b>		115

Order No. supplements, see from Page 1/36.



# IEC Squirrel-Cage Motors

## New Generation 1LE1/1PC1

Self-ventilated motors with increased output  
and high efficiency

### Selection and ordering data (continued)

Order No.	Locked-rotor torque	Locked-rotor current	Breakdown torque	Torque class	Moment of inertia	Noise at rated output	
	with direct starting as multiple of rated torque	as multiple of rated current	torque			Measuring-surface sound pressure level at 50 Hz	Sound pressure level at 50 Hz
	$T_{LR}/T_{rated}$	$I_{LR}/I_{rated}$	$T_B/T_{rated}$	CL	$J$ kgm <sup>2</sup>	$L_{pFA}$ dB(A)	$L_{WA}$ dB(A)
<b>Motor version: temperature class 155 (F), IP55 degree of protection, with increased output, used acc. to temperature class 130 (B)</b>							
<b>2-pole – 3000 rpm at 50 Hz, 3600 rpm at 60 Hz</b>							
<b>1LE1001-1AA6□-□□□□</b>	2.5	7.6	3.5	16	0.0054	67	79
<b>1LE1001-1BA6□-□□□□</b>	2.2	7.7	3.3	16	0.0119	73	85
<b>1LE1001-1CA6□-□□□□</b>	2.5	7.9	3.2	16	0.03143	68	80
<b>1LE1001-1DA6□-□□□□</b>	3.1	8.4	3.7	16	0.06764	70	82
<b>4-pole – 1500 rpm at 50 Hz, 1800 rpm at 60 Hz</b>							
<b>1LE1001-1AB6□-□□□□</b>	2.2	7.5	3.5	16	0.0137	60	72
<b>1LE1001-1BB6□-□□□□</b>	2.5	7.1	3.1	16	0.0166	58	70
<b>1LE1001-1CB6□-□□□□</b>	2.9	7.7	3.1	16	0.04571	64	76
<b>1LE1001-1DB6□-□□□□</b>	2.8	7.7	3.3	16	0.09854	65	77
<b>6-pole – 1000 rpm at 50 Hz, 1200 rpm at 60 Hz</b>							
<b>1LE1001-1AC6□-□□□□</b>	1.9	5.7	2.9	16	0.0137	59	71
<b>1LE1001-1BC6□-□□□□</b>	2.1	6	3.1	16	0.0166	57	69
<b>1LE1001-1CC6□-□□□□</b>	2.1	6.5	3	16	0.04572	63	75
<b>1LE1001-1DC6□-□□□□</b>	1.9	6.5	2.9	16	0.1208	67	79

# IEC Squirrel-Cage Motors

## New Generation 1LE1/1PC1

Self-ventilated motors with increased output and high efficiency

### Selection and ordering data (continued)

#### Order No. supplements

Motor type	Frame size	Positions 12 and 13: Voltages (voltage codes)							
		Standard voltages				Further voltages			
		50 Hz				50 Hz			
		230 VΔ/400 VY	400 VΔ/690 VY	500 VY	500 VΔ	220 VΔ/380 VY	380 VΔ/660 VY	415 VY	415 VΔ
		60 Hz				Rated voltage range			
		460 VY	460 VΔ			(210 ... 230 VΔ/ 360 ... 400 VY) <sup>1)</sup>	(360 ... 400 VΔ/ 625 ... 695 VY) <sup>1)</sup>	(395 ... 435 VY) <sup>1)</sup>	(395 ... 435 VΔ) <sup>1)</sup>
		see "Selection and ordering data" for outputs at 60 Hz							
		<b>22</b>	<b>34</b>	<b>27</b>	<b>40</b>	<b>21</b>	<b>33</b>	<b>23</b>	<b>35</b>
1LE1001-1A...-Q-Q...	100 L	○	○	○	○	✓	✓	✓	✓
1LE1001-1B...-Q-Q...	112 M	○	○	○	○	✓	✓	✓	✓
1LE1001-1C...-Q-Q...	132 M	○	○	○	○	✓	✓	✓	✓
1LE1001-1D...-Q-Q...	160 L	○	○	○	○	✓	✓	✓	✓

- Without additional charge  
 ✓ With additional charge

Order other voltages with voltage code **9** in position 12, code **0** in position 13 and the corresponding order code (see "Special versions" in the "Selection and ordering data" under "Voltages", Page 1/54).

Motor type	Frame size	Position 14: Types of construction (type letter)												
		Without flange						With flange (acc. to DIN EN 50347)						
		IM B3 <sup>2)3)</sup>	IM B6 <sup>3)</sup>	IM B7 <sup>3)</sup>	IM B8 <sup>3)</sup>	IM V6 <sup>3)</sup>	IM V5 without protective cover <sup>3)</sup>	IM V5 with protective cover <sup>3)4)5)</sup>	Flange size	IM B5 <sup>3)6)</sup>	IM V1 without protective cover <sup>3)</sup>	IM V1 with protective cover <sup>3)4)5)</sup>	IM V3 <sup>3)</sup>	IM B35
		<b>A</b>	<b>T</b>	<b>U</b>	<b>V</b>	<b>D</b>	<b>C</b>	<b>C</b>	<b>F</b>	<b>G</b>	<b>G</b>	<b>H</b>	<b>J</b>	
		Order No. supplement <b>-Z</b> with order code												
		-	-	-	-	-	-	<b>-Z H00</b>	-	-	<b>-Z H00</b>	-	-	
1LE1001-1A...-Q..	100 L	□	□	□	□	□	□	✓	<b>FF 215</b>	✓	✓	✓	✓	
1LE1001-1B...-Q..	112 M	□	□	□	□	□	□	✓	<b>FF 215</b>	✓	✓	✓	✓	
1LE1001-1C...-Q..	132 M	□	□	□	□	□	□	✓	<b>FF 265</b>	✓	✓	✓	✓	
1LE1001-1D...-Q..	160 L	□	□	□	□	□	□	✓	<b>FF 300</b>	✓	✓	✓	✓	

Motor type	Frame size	Position 14: Types of construction (type letter)											
		With standard flange (acc. to DIN EN 50347)					With standard flange (next larger standard flange acc. to DIN EN 50347)						
		Flange size	IM B14 <sup>3)7)</sup>	IM V19 <sup>3)</sup>	IM V18 without protective cover <sup>3)</sup>	IM V18 with protective cover <sup>3)4)5)</sup>	IM B34	Flange size	IM B14 <sup>3)7)</sup>	IM V19 <sup>3)</sup>	IM V18 without protective cover <sup>3)</sup>	IM V18 with protective cover <sup>3)4)5)</sup>	IM B34
			<b>K</b>	<b>L</b>	<b>M</b>	<b>N</b>		<b>K</b>	<b>L</b>	<b>M</b>	<b>M</b>	<b>N</b>	
		Order No. supplement <b>-Z</b> with order code											
			-	-	-	<b>-Z H00</b>	-	<b>-Z</b>	<b>-Z</b>	<b>-Z</b>	<b>-Z H00</b>	<b>-Z P01</b>	<b>-Z P01</b>
1LE1001-1A...-Q..	100 L	<b>FT 130</b>	✓	✓	✓	✓	✓	<b>FT 165</b>	✓	✓	✓	✓	✓
1LE1001-1B...-Q..	112 M	<b>FT 130</b>	✓	✓	✓	✓	✓	<b>FT 165</b>	✓	✓	✓	✓	✓
1LE1001-1C...-Q..	132 S/M	<b>FT 165</b>	✓	✓	✓	✓	✓	<b>FT 215</b>	✓	✓	✓	✓	✓
1LE1001-1D...-Q..	160 M/L	<b>FT 215</b>	✓	✓	✓	✓	✓	-	-	-	-	-	-

- Standard version  
 ✓ With additional charge

<sup>1)</sup> A rated voltage range is also specified on the rating plate.

<sup>2)</sup> The types of construction IM B6/7/8, IM V6 and IM V5 without protective cover/with protective cover are also possible as long as no condensation drainage holes (order code **H03**) and no stamping of these types of construction on the rating plate are required. As standard, the type of construction IM B3 is then stamped on the rating plate. With type of construction IM V5 with protective cover, the protective cover has to be additionally ordered with order code **H00**. The protective cover is not stamped on the rating plate.

<sup>3)</sup> The type of construction is stamped on the rating plate. When ordering with condensation drainage holes (order code **H03**), it is absolutely necessary to specify the type of construction for the exact position of the condensation drainage holes during manufacture.

<sup>4)</sup> Option second shaft extension (order code **L05**) not possible.

<sup>5)</sup> In combination with an encoder, it is not necessary to order the protective cover (order code **H00**), as this is delivered as a protection for the encoder as standard. In this case, the protective cover is standard design (without additional charge).

<sup>6)</sup> The types of construction IM V3 and IM V1 without protective cover/with protective cover are also possible as long as no condensation drainage holes (order code **H03**) and no stamping of these types of construction on the rating plate are required. As standard, the type of construction IM B5 is then stamped on the rating plate. With type of construction IM V1 with protective cover, the protective cover has to be additionally ordered with order code **H00**. The protective cover is not stamped on the rating plate.

<sup>7)</sup> The types of construction IM V19 and IM V18 without protective cover/with protective cover are also possible as long as no condensation drainage holes (order code **H03**) and no stamping of these types of construction on the rating plate are required. As standard, the type of construction IM B14 is then stamped on the rating plate. With type of construction IM V18 with protective cover, the protective cover has to be additionally ordered with order code **H00**. The protective cover is not stamped on the rating plate.

# IEC Squirrel-Cage Motors

## New Generation 1LE1/1PC1

Self-ventilated motors with increased output  
and high efficiency

### Selection and ordering data (continued)

Motor type	Frame size	Position 15: Motor protection (motor protection letter)					
		Without motor protection	Motor protection with PTC thermistors with 3 embedded temperature sensors for tripping <sup>1)</sup>	Motor protection with PTC thermistors with 6 embedded temperature sensors for alarm and tripping <sup>1)</sup>	Motor temperature detection with embedded temperature sensor KTY 84-130 <sup>1)</sup>	NTC thermistors for tripping	Temperature detectors for tripping <sup>1)</sup>
Order code		A	B	C	F	Z Q2A	Z Q3A
1LE1001-1A...-...□	100 L	□	✓	✓	✓	✓	✓
1LE1001-1B...-...□	112 M	□	✓	✓	✓	✓	✓
1LE1001-1C...-...□	132 M	□	✓	✓	✓	✓	✓
1LE1001-1D...-...□	160 L	□	✓	✓	✓	✓	✓

- Standard version  
✓ With additional charge

Motor type	Frame size	Position 16: Connection box (connection box code)			
		Connection box top <sup>2)</sup>	Connection box on RHS <sup>2)</sup>	Connection box on LHS <sup>2)</sup>	Connection box bottom <sup>2)</sup>
		4	5	6	7
1LE1001-1A...-...□	100 L	□	✓	✓	✓
1LE1001-1B...-...□	112 M	□	✓	✓	✓
1LE1001-1C...-...□	132 M	□	✓	✓	✓
1LE1001-1D...-...□	160 L	□	✓	✓	✓

- Standard version  
✓ With additional charge

<sup>1)</sup> Evaluation with appropriate tripping unit (see Catalog LV 1) is recommended.

<sup>2)</sup> With type of construction, screwed-on feet as standard.

# IEC Squirrel-Cage Motors

## New Generation 1LE1/1PC1

Forced-air cooled motors without external fan and fan cover with improved efficiency

### Selection and ordering data

Rated output at		Frame size	Operating values at rated output							Order No. with -Z and order code	Price	Weight
50 Hz	60 Hz		Rated speed at 50 Hz	Rated torque at 50 Hz	Efficiency Class according to CEMEP	Efficiency at 50 Hz 4/4-load	Efficiency at 50 Hz 3/4-load	Power factor at 50 Hz 4/4-load	Rated current at 400 V, 50 Hz			
$P_{rated}$ kW	$P_{rated}$ kW	FS	$n_{rated}$ rpm	$T_{rated}$ Nm		$\eta_{rated}$ %	$\eta_{rated}$ %	$\cos\varphi_{rated}$	$I_{rated}$ A	For Order No. supplements for voltage, type of construction, motor protection and connection box, see table from Page 1/40.	IM B3 type of construction	IM B3 type of construction approx. $m$ kg
<b>Motor version: temperature class 155 (F), IP55 degree of protection, used acc. to temperature class 130 (B)</b>												
<b>2-pole – 3000 rpm at 50 Hz, 3600 rpm at 60 Hz</b>												
3	3.45	100 L	2835	10	EFF2	82.6	83.2	0.87	6	<b>1LE1002-1AA4Q-0000-Z F90</b>		20
4	4.6	112 M	2930	13	EFF2	84.8	84.4	0.86	7.9	<b>1LE1002-1BA2Q-0000-Z F90</b>		25
5.5	6.3	132 S	2905	18	EFF2	86	86.6	0.89	10.4	<b>1LE1002-1CA0Q-0000-Z F90</b>		35
7.5	8.6	132 S	2925	24	EFF2	87.6	88.7	0.88	14	<b>1LE1002-1CA1Q-0000-Z F90</b>		40
11	12.6	160 M	2920	36	EFF2	88.4	88.5	0.85	21	<b>1LE1002-1DA2Q-0000-Z F90</b>		60
15	17.3	160 M	2930	49	EFF2	89.5	89.7	0.84	29	<b>1LE1002-1DA3Q-0000-Z F90</b>		68
18.5	21.3	160 L	2935	60	EFF2	90.9	91	0.86	34	<b>1LE1002-1DA4Q-0000-Z F90</b>		78
<b>4-pole – 1500 rpm at 50 Hz, 1800 rpm at 60 Hz</b>												
2.2	2.55	100 L	1425	14.8	EFF2	81	84	0.81	4.85	<b>1LE1002-1AB4Q-0000-Z F90</b>		18
3	3.45	100 L	1425	20.2	EFF2	82.8	83.6	0.85	6.2	<b>1LE1002-1AB5Q-0000-Z F90</b>		22
4	4.6	112 M	1435	27	EFF2	84.2	85.1	0.84	8.2	<b>1LE1002-1BB2Q-0000-Z F90</b>		27
5.5	6.3	132 S	1450	36	EFF2	86	86.5	0.83	11.2	<b>1LE1002-1CB0Q-0000-Z F90</b>		38
7.5	8.6	132 M	1450	49	EFF2	87	87.4	0.83	15	<b>1LE1002-1CB2Q-0000-Z F90</b>		44
11	12.6	160 M	1460	72	EFF2	88.4	88.1	0.82	22	<b>1LE1002-1DB2Q-0000-Z F90</b>		62
15	17.3	160 L	1460	98	EFF2	89.4	89.7	0.82	29.5	<b>1LE1002-1DB4Q-0000-Z F90</b>		73
<b>6-pole – 1000 rpm at 50 Hz, 1200 rpm at 60 Hz</b>												
1.5	1.75	100 L	940	15.3		74	72.6	0.74	3.95	<b>1LE1002-1AC4Q-0000-Z F90</b>		19
2.2	2.55	112 M	930	23		78	78.1	0.77	5.3	<b>1LE1002-1BC2Q-0000-Z F90</b>		25
3	3.45	132 S	955	30		80	79.4	0.74	7.3	<b>1LE1002-1CC0Q-0000-Z F90</b>		34
4	4.6	132 M	950	40		83	83.4	0.76	9.2	<b>1LE1002-1CC2Q-0000-Z F90</b>		39
5.5	6.3	132 M	950	55		85	85.3	0.75	12.4	<b>1LE1002-1CC3Q-0000-Z F90</b>		48
7.5	8.6	160 M	970	75		86	85.4	0.73	17.2	<b>1LE1002-1DC2Q-0000-Z F90</b>		72
11	12.6	160 L	965	110		87.6	87.9	0.77	23.5	<b>1LE1002-1DC4Q-0000-Z F90</b>		92
<b>8-pole – 750 rpm at 50 Hz, 900 rpm at 60 Hz</b>												
0.75	0.86	100 L	705	10.4		65.4	60.2	0.62	2.65	<b>1LE1002-1AD4Q-0000-Z F90</b>		17
1.1	1.3	100 L	705	15.1		68.3	67.6	0.63	3.71	<b>1LE1002-1AD5Q-0000-Z F90</b>		22
1.5	1.75	112 M	700	20		75.9	72.8	0.68	4.2	<b>1LE1002-1BD2Q-0000-Z F90</b>		25
2.2	2.55	132 S	715	29		81	80	0.66	5.9	<b>1LE1002-1CD0Q-0000-Z F90</b>		37
3	3.45	132 M	710	40		81.6	81	0.68	7.8	<b>1LE1002-1CD2Q-0000-Z F90</b>		44
4	4.6	160 M	720	53		80	78.7	0.69	10.4	<b>1LE1002-1DD2Q-0000-Z F90</b>		60
5.5	6.3	160 M	720	73		83.5	83.9	0.70	13.6	<b>1LE1002-1DD3Q-0000-Z F90</b>		72
7.5	8.6	160 L	715	100		83.5	84.7	0.70	18.6	<b>1LE1002-1DD4Q-0000-Z F90</b>		91

Order No. supplements, see from Page 1/40.

# IEC Squirrel-Cage Motors

## New Generation 1LE1/1PC1

Forced-air cooled motors without external fan and fan cover with improved efficiency

### Selection and ordering data (continued)

Order No. with -Z and order code	Locked-rotor torque	Locked-rotor current	Breakdown torque	Torque class	Moment of inertia	Noise at rated output	
	with direct starting as multiple of rated torque	as multiple of rated current	torque			Measuring-surface sound pressure level at 50 Hz	Sound pressure level at 50 Hz
	$T_{LR}/T_{rated}$	$I_{LR}/I_{rated}$	$T_B/T_{rated}$	CL	$J$ kgm <sup>2</sup>	$L_{pA}$ dB(A)	$L_{WA}$ dB(A)
<b>Motor version: temperature class 155 (F), IP55 degree of protection, used acc. to temperature class 130 (B)</b>							
<b>2-pole – 3000 rpm at 50 Hz, 3600 rpm at 60 Hz</b>							
1LE1002-1AA4Q-QQQQ-Z F90	3.2	6.2	2.9	16	0.0034	67	79
1LE1002-1BA2Q-QQQQ-Z F90	2.7	7.3	3.7	16	0.0067	69	81
1LE1002-1CA0Q-QQQQ-Z F90	2	5.6	2.6	16	0.01267	68	80
1LE1002-1CA1Q-QQQQ-Z F90	2.2	6.4	3	16	0.01601	68	80
1LE1002-1DA2Q-QQQQ-Z F90	2.1	6.1	2.7	16	0.02971	70	82
1LE1002-1DA3Q-QQQQ-Z F90	2.5	6.1	3.2	16	0.03619	70	82
1LE1002-1DA4Q-QQQQ-Z F90	2.5	7	3.2	16	0.04395	70	82
<b>4-pole – 1500 rpm at 50 Hz, 1800 rpm at 60 Hz</b>							
1LE1002-1AB4Q-QQQQ-Z F90	2.3	5.1	2.7	16	0.0059	60	72
1LE1002-1AB5Q-QQQQ-Z F90	2.4	5.4	2.6	16	0.0078	60	72
1LE1002-1BB2Q-QQQQ-Z F90	2.2	5.3	2.6	16	0.0102	58	70
1LE1002-1CB0Q-QQQQ-Z F90	2.3	6.2	2.7	16	0.0186	64	76
1LE1002-1CB2Q-QQQQ-Z F90	2.5	6.6	2.9	16	0.02371	64	76
1LE1002-1DB2Q-QQQQ-Z F90	2.3	6.4	3.1	16	0.04395	65	77
1LE1002-1DB4Q-QQQQ-Z F90	2.5	7	3.4	16	0.05616	65	77
<b>6-pole – 1000 rpm at 50 Hz, 1200 rpm at 60 Hz</b>							
1LE1002-1AC4Q-QQQQ-Z F90	2	4	2.2	16	0.0065	59	71
1LE1002-1BC2Q-QQQQ-Z F90	2.3	4.1	2.5	16	0.0092	57	69
1LE1002-1CC0Q-QQQQ-Z F90	2	4.6	2.6	16	0.0167	63	75
1LE1002-1CC2Q-QQQQ-Z F90	2.1	4.7	2.5	16	0.02116	63	75
1LE1002-1CC3Q-QQQQ-Z F90	2.5	5.2	2.8	16	0.02734	63	75
1LE1002-1DC2Q-QQQQ-Z F90	2.1	5.5	2.9	16	0.04993	68	80
1LE1002-1DC4Q-QQQQ-Z F90	1.9	5.9	2.7	16	0.0678	68	80
<b>8-pole – 750 rpm at 50 Hz, 900 rpm at 60 Hz</b>							
1LE1002-1AD4Q-QQQQ-Z F90	1.9	3	2.2	16	0.0056	60	72
1LE1002-1AD5Q-QQQQ-Z F90	2	3.2	2.3	16	0.0078	60	72
1LE1002-1BD2Q-QQQQ-Z F90	1.9	3.4	2.1	16	0.0094	63	75
1LE1002-1CD0Q-QQQQ-Z F90	1.7	3.9	2.4	13	0.0186	63	75
1LE1002-1CD2Q-QQQQ-Z F90	1.8	3.9	2.2	13	0.02372	63	75
1LE1002-1DD2Q-QQQQ-Z F90	1.7	3.8	2.3	13	0.0439	63	75
1LE1002-1DD3Q-QQQQ-Z F90	1.6	4	2.2	13	0.0562	63	75
1LE1002-1DD4Q-QQQQ-Z F90	1.7	3.8	2.2	13	0.0772	63	75

# IEC Squirrel-Cage Motors

## New Generation 1LE1/1PC1

Forced-air cooled motors without external fan and fan cover with improved efficiency

### Selection and ordering data (continued)

#### Order No. supplements

Motor type	Frame size	Positions 12 and 13: Voltages (voltage codes)					Further voltages			
		Standard voltages					50 Hz			
		50 Hz	230 VΔ/400 VY	400 VΔ/690 VY	500 VY	500 VΔ	220 VΔ/380 VY	380 VΔ/660 VY	415 VY	415 VΔ
		60 Hz	460 VY	460 VΔ			Rated voltage range			
							(210 ... 230 VΔ/360 ... 400 VY) <sup>1)</sup> (360 ... 400 VΔ/625 ... 695 VY) <sup>1)</sup> (395 ... 435 VY) <sup>1)</sup> (395 ... 435 VΔ) <sup>1)</sup>			
		see "Selection and ordering data" for outputs at 60 Hz								
		<b>22</b>	<b>34</b>	<b>27</b>	<b>40</b>	<b>21</b>	<b>33</b>	<b>23</b>	<b>35</b>	
1LE1002-1A...-□...-Z F90	100 L	○	○	○	○	✓	✓	✓	✓	
1LE1002-1B...-□...-Z F90	112 M	○	○	○	○	✓	✓	✓	✓	
1LE1002-1C...-□...-Z F90	132 S/M	○	○	○	○	✓	✓	✓	✓	
1LE1002-1D...-□...-Z F90	160 M/L	○	○	○	○	✓	✓	✓	✓	

- Without additional charge  
 ✓ With additional charge

Order other voltages with voltage code **9** in position 12, code **0** in position 13 and the corresponding order code (see "Special versions" in the "Selection and ordering data" under "Voltages", Page 1/54).

Motor type	Frame size	Position 14: Types of construction (type letter)										
		Without flange							With flange (acc. to DIN EN 50347)			
		IM B3 2)3)	IM B6 3)	IM B7 3)	IM B8 3)	IM V6 3)	IM V5 without protective cover <sup>3)</sup>	Flange size	IM B5 3)4)	IM V1 without protective cover <sup>3)</sup>	IM V3 3)	IM B35
		<b>A</b>	<b>T</b>	<b>U</b>	<b>V</b>	<b>D</b>	<b>C</b>		<b>F</b>	<b>G</b>	<b>H</b>	<b>J</b>
		Order No. supplement -Z with order code										
1LE1002-1A...-□...-Z F90	100 L	□	□	□	□	□	□	FF 215	✓	✓	✓	✓
1LE1002-1B...-□...-Z F90	112 M	□	□	□	□	□	□	FF 215	✓	✓	✓	✓
1LE1002-1C...-□...-Z F90	132 S/M	□	□	□	□	□	□	FF 265	✓	✓	✓	✓
1LE1002-1D...-□...-Z F90	160 M/L	□	□	□	□	□	□	FF 300	✓	✓	✓	✓

Motor type	Frame size	Position 14: Types of construction (type letter)									
		With standard flange (acc. to DIN EN 50347)					With standard flange (next larger standard flange acc. to DIN EN 50347)				
		Flange size	IM B14 3)5)	IM V19 3)	IM V18 without protective cover <sup>3)</sup>	IM B34	Flange size	IM B14 3)5)	IM V19 3)	IM V18 without protective cover <sup>3)</sup>	IM B34
			<b>K</b>	<b>L</b>	<b>M</b>	<b>N</b>		<b>K</b>	<b>L</b>	<b>M</b>	<b>N</b>
		Order No. supplement -Z with order code									
			-	-	-	-		<b>-Z</b>	<b>-Z</b>	<b>-Z</b>	<b>-Z</b>
			<b>P01</b>	<b>P01</b>	<b>P01</b>	<b>P01</b>		<b>P01</b>	<b>P01</b>	<b>P01</b>	<b>P01</b>
1LE1002-1A...-□...-Z F90	100 L	FT 130	✓	✓	✓	✓	FT 165	✓	✓	✓	✓
1LE1002-1B...-□...-Z F90	112 M	FT 130	✓	✓	✓	✓	FT 165	✓	✓	✓	✓
1LE1002-1C...-□...-Z F90	132 S/M	FT 165	✓	✓	✓	✓	FT 215	✓	✓	✓	✓
1LE1002-1D...-□...-Z F90	160 M/L	FT 215	✓	✓	✓	✓	-	-	-	-	-

- Standard version  
 ✓ With additional charge

- 1) A rated voltage range is also specified on the rating plate.  
 2) The types of construction IM B6/7/8, IM V6 and IM V5 without protective cover are also possible as long as no condensation drainage holes (order code **H03**) and no stamping of these types of construction on the rating plate are required. As standard, the type of construction IM B3 is then stamped on the rating plate.  
 3) The type of construction is stamped on the rating plate. When ordering with condensation drainage holes (order code **H03**), it is absolutely necessary to specify the type of construction for the exact position of the condensation drainage holes during manufacture.

- 4) The types of construction IM V3 and IM V1 without protective cover are also possible as long as no condensation drainage holes (order code **H03**) and no stamping of these types of construction on the rating plate are required. As standard, the type of construction IM B5 is then stamped on the rating plate.  
 5) The types of construction IM V19 and IM V18 without protective cover are also possible as long as no condensation drainage holes (order code **H03**) and no stamping of these types of construction on the rating plate are required. As standard, the type of construction IM B14 is then stamped on the rating plate.

# IEC Squirrel-Cage Motors

## New Generation 1LE1/1PC1

Forced-air cooled motors without external fan and fan cover with improved efficiency

### Selection and ordering data (continued)

Motor type	Frame size	Position 15: Motor protection (motor protection letter)					
		Without motor protection	Motor protection with PTC thermistors with 3 embedded temperature sensors for tripping <sup>1)</sup>	Motor protection with PTC thermistors with 6 embedded temperature sensors for alarm and tripping <sup>1)</sup>	Motor temperature detection with embedded temperature sensor KTY 84-130 <sup>1)</sup>	NTC thermistors for tripping	Temperature detectors for tripping <sup>1)</sup>
Order code		A	B	C	F	Z Q2A	Z Q3A
1LE1002-1A...-...Q-Z F90	100 L	☐	✓	✓	✓	✓	✓
1LE1002-1B...-...Q-Z F90	112 M	☐	✓	✓	✓	✓	✓
1LE1002-1C...-...Q-Z F90	132 S/M	☐	✓	✓	✓	✓	✓
1LE1002-1D...-...Q-Z F90	160 M/L	☐	✓	✓	✓	✓	✓

- ☐ Standard version  
 ✓ With additional charge

Motor type	Frame size	Position 16: Connection box (connection box code)			
		Connection box top <sup>2)</sup>	Connection box on RHS <sup>3)</sup>	Connection box on LHS <sup>3)</sup>	Connection box bottom <sup>3)</sup>
		4	5	6	7
1LE1002-1A...-...Q-Z F90	100 L	☐	✓	✓	✓
1LE1002-1B...-...Q-Z F90	112 M	☐	✓	✓	✓
1LE1002-1C...-...Q-Z F90	132 S/M	☐	✓	✓	✓
1LE1002-1D...-...Q-Z F90	160 M/L	☐	✓	✓	✓

- ☐ Standard version  
 ✓ With additional charge

<sup>1)</sup> Evaluation with appropriate tripping unit (see Catalog LV 1) is recommended.

<sup>2)</sup> With type of construction, cast feet as standard. Screwed-on feet are available with order code **H01**, see "Special versions".

<sup>3)</sup> With type of construction, screwed-on feet as standard.

# IEC Squirrel-Cage Motors

## New Generation 1LE1/1PC1

Forced-air cooled motors without external fan and fan cover with high efficiency

### Selection and ordering data (continued)

Rated output at		Frame size	Operating values at rated output							Order No. with -Z and order code	Price	Weight
50 Hz	60 Hz		Rated speed at 50 Hz	Rated torque at 50 Hz	Efficiency Class according to CEMEP	Efficiency at 50 Hz 4/4-load	Efficiency at 50 Hz 3/4-load	Power factor at 50 Hz 4/4-load	Rated current at 400 V, 50 Hz			
$P_{rated}$ kW	$P_{rated}$ kW	FS	$n_{rated}$ rpm	$T_{rated}$ Nm	EFF1	$\eta_{rated}$ %	$\eta_{rated}$ %	$\cos\varphi_{rated}$	$I_{rated}$ A	For Order No. supplements for voltage, type of construction, motor protection and connection box, see table from Page 1/44.	IM B3 type of construction	IM B3 type of construction approx. $m$ kg
<b>Motor version: temperature class 155 (F), IP55 degree of protection, used acc. to temperature class 130 (B)</b>												
<b>2-pole – 3000 rpm at 50 Hz, 3600 rpm at 60 Hz</b>												
3	3.45	100 L	2905	9.9	EFF1	86.7	87.5	0.84	5.9	1LE1001-1AA4Q-0000-Z F90		21
4	4.6	112 M	2950	13	EFF1	88	88.5	0.86	7.4	1LE1001-1BA2Q-0000-Z F90		27
5.5	6.3	132 S	2950	18	EFF1	89.5	90.6	0.87	10.2	1LE1001-1CA0Q-0000-Z F90		39
7.5	8.6	132 S	2950	24	EFF1	90	91	0.87	13.8	1LE1001-1CA1Q-0000-Z F90		43
11	12.6	160 M	2955	36	EFF1	90.8	91	0.87	20	1LE1001-1DA2Q-0000-Z F90		67
15	17.3	160 M	2955	48	EFF1	91.4	91.5	0.88	27	1LE1001-1DA3Q-0000-Z F90		75
18.5	21.3	160 L	2955	60	EFF1	92	92.5	0.88	33	1LE1001-1DA4Q-0000-Z F90		84
<b>4-pole – 1500 rpm at 50 Hz, 1800 rpm at 60 Hz</b>												
2.2	2.55	100 L	1455	14	EFF1	86.4	87	0.81	4.55	1LE1001-1AB4Q-0000-Z F90		21
3	3.45	100 L	1455	20	EFF1	87.4	88	0.82	6	1LE1001-1AB5Q-0000-Z F90		25
4	4.6	112 M	1460	26	EFF1	88.3	88.5	0.81	8.1	1LE1001-1BB2Q-0000-Z F90		29
5.5	6.3	132 S	1465	36	EFF1	89.2	89.5	0.80	11.2	1LE1001-1CB0Q-0000-Z F90		42
7.5	8.6	132 M	1465	49	EFF1	90.1	91	0.83	14.4	1LE1001-1CB2Q-0000-Z F90		49
11	12.6	160 M	1470	71	EFF1	91.2	91.8	0.85	20.5	1LE1001-1DB2Q-0000-Z F90		71
15	17.3	160 L	1475	97	EFF1	92	92.4	0.85	27.5	1LE1001-1DB4Q-0000-Z F90		83
<b>6-pole – 1000 rpm at 50 Hz, 1200 rpm at 60 Hz</b>												
1.5	1.75	100 L	970	15		84.5	84.5	0.73	3.5	1LE1001-1AC4Q-0000-Z F90		25
2.2	2.55	112 M	965	22		85	85	0.75	5	1LE1001-1BC2Q-0000-Z F90		29
3	3.45	132 S	970	30		85	85	0.74	6.9	1LE1001-1CC0Q-0000-Z F90		38
4	4.6	132 M	970	39		86	86	0.78	8.6	1LE1001-1CC2Q-0000-Z F90		43
5.5	6.3	132 M	970	54		88	88	0.77	11.8	1LE1001-1CC3Q-0000-Z F90		52
7.5	8.6	160 M	975	73		89	89	0.77	15.8	1LE1001-1DC2Q-0000-Z F90		77
11	12.6	160 L	975	108		89.5	89	0.80	22	1LE1001-1DC4Q-0000-Z F90		93
<b>8-pole – 750 rpm at 50 Hz, 900 rpm at 60 Hz</b>												
0.75	0.86	100 L	725	9.9		68	65	0.58	2.75	1LE1001-1AD4Q-0000-Z F90		21
1.1	1.3	110 L	725	14		68	64.5	0.58	4.05	1LE1001-1AD5Q-0000-Z F90		25
1.5	1.75	112 M	720	20		77	75.5	0.67	4.2	1LE1001-1BD2Q-0000-Z F90		29
2.2	2.55	132 S	725	29		77.5	76.7	0.63	6.5	1LE1001-1CD0Q-0000-Z F90		41
3	3.45	132 M	730	40		84	82	0.65	7.9	1LE1001-1CD2Q-0000-Z F90		49
4	4.6	160 M	730	52		87	88	0.69	9.6	1LE1001-1DD2Q-0000-Z F90		69
5.5	6.3	160 M	735	72		87.5	89	0.69	13.2	1LE1001-1DD3Q-0000-Z F90		82
7.5	8.6	160 L	730	98		88	89	0.72	17	1LE1001-1DD4Q-0000-Z F90		94

Order No. supplements, see from Page 1/44.



# IEC Squirrel-Cage Motors

## New Generation 1LE1/1PC1

Forced-air cooled motors without external fan and fan cover with high efficiency

### Selection and ordering data (continued)

Order No. with -Z and order code	Locked-rotor torque	Locked-rotor current	Breakdown torque	Torque class	Moment of inertia	Noise at rated output	
	with direct starting as multiple of rated torque	as multiple of rated current	torque			Measuring-surface sound pressure level at 50 Hz	Sound pressure level at 50 Hz
	$T_{LR}/T_{rated}$	$I_{LR}/I_{rated}$	$T_B/T_{rated}$	CL	$J$ kgm <sup>2</sup>	$L_{pA}$ dB(A)	$L_{WA}$ dB(A)
<b>Motor version: temperature class 155 (F), IP55 degree of protection, used acc. to temperature class 130 (B)</b>							
<b>2-pole – 3000 rpm at 50 Hz, 3600 rpm at 60 Hz</b>							
1LE1001-1AA4Q-QQQQ-Z F90	2.3	7	3.3	16	0.0044	67	79
1LE1001-1BA2Q-QQQQ-Z F90	2.4	7.4	3.3	16	0.0092	69	81
1LE1001-1CA0Q-QQQQ-Z F90	1.8	6.7	2.9	16	0.02012	68	80
1LE1001-1CA1Q-QQQQ-Z F90	2.2	7.5	3.1	16	0.02353	68	80
1LE1001-1DA2Q-QQQQ-Z F90	2.1	7.4	3.2	16	0.04471	70	82
1LE1001-1DA3Q-QQQQ-Z F90	2.4	7.6	3.4	16	0.05277	70	82
1LE1001-1DA4Q-QQQQ-Z F90	2.9	7.9	3.6	16	0.06085	70	82
<b>4-pole – 1500 rpm at 50 Hz, 1800 rpm at 60 Hz</b>							
1LE1001-1AB4Q-QQQQ-Z F90	2.1	6.9	3.3	16	0.0086	60	72
1LE1001-1AB5Q-QQQQ-Z F90	2	6.9	3.1	16	0.0109	60	72
1LE1001-1BB2Q-QQQQ-Z F90	2.5	7.1	3.2	16	0.014	58	70
1LE1001-1CB0Q-QQQQ-Z F90	2.3	6.9	2.9	16	0.02698	64	76
1LE1001-1CB2Q-QQQQ-Z F90	2.3	6.9	2.9	16	0.03353	64	76
1LE1001-1DB2Q-QQQQ-Z F90	2.2	6.7	2.8	16	0.06495	65	77
1LE1001-1DB4Q-QQQQ-Z F90	2.5	7.3	3	16	0.08281	65	77
<b>6-pole – 1000 rpm at 50 Hz, 1200 rpm at 60 Hz</b>							
1LE1001-1AC4Q-QQQQ-Z F90	2	6.2	2.9	16	0.0113	59	71
1LE1001-1BC2Q-QQQQ-Z F90	2.1	6	3.1	16	0.0139	57	69
1LE1001-1CC0Q-QQQQ-Z F90	1.6	5.6	2.6	13	0.02371	63	75
1LE1001-1CC2Q-QQQQ-Z F90	1.6	5.6	2.5	13	0.02918	63	75
1LE1001-1CC3Q-QQQQ-Z F90	1.9	6.1	2.8	16	0.03673	63	75
1LE1001-1DC2Q-QQQQ-Z F90	1.8	6.3	2.8	16	0.0754	67	79
1LE1001-1DC4Q-QQQQ-Z F90	1.7	6.2	2.7	16	0.0975	67	79
<b>8-pole – 750 rpm at 50 Hz, 900 rpm at 60 Hz</b>							
1LE1001-1AD4Q-QQQQ-Z F90	1.6	4	2.8	13	0.0086	60	72
1LE1001-1AD5Q-QQQQ-Z F90	1.8	4	2.8	13	0.0109	60	72
1LE1001-1BD2Q-QQQQ-Z F90	1.4	4.2	2.4	13	0.014	63	75
1LE1001-1CD0Q-QQQQ-Z F90	1.4	3.6	1.8	10	0.02698	63	75
1LE1001-1CD2Q-QQQQ-Z F90	1.4	5	2.4	10	0.03463	63	75
1LE1001-1DD2Q-QQQQ-Z F90	1.8	4.3	2	13	0.0649	63	75
1LE1001-1DD3Q-QQQQ-Z F90	2.1	4.4	2.1	13	0.0828	63	75
1LE1001-1DD4Q-QQQQ-Z F90	1.9	4.5	2.1	13	0.0982	63	75

# IEC Squirrel-Cage Motors

## New Generation 1LE1/1PC1

Forced-air cooled motors without external fan and fan cover with high efficiency

### Selection and ordering data (continued)

#### Order No. supplements

Motor type	Frame size	Positions 12 and 13: Voltages (voltage codes)					Further voltages				
		Standard voltages					50 Hz				
		50 Hz				220 VΔ/380 VY	380 VΔ/660 VY	415 VY	415 VΔ		
		230 VΔ/400 VY	400 VΔ/690 VY	500 VY	500 VΔ						
		60 Hz					Rated voltage range				
		460 VY	460 VΔ			(210 ... 230 VΔ/360 ... 400 VY) <sup>1)</sup>	(360 ... 400 VΔ/625 ... 695 VY) <sup>1)</sup>	(395 ... 435 VY) <sup>1)</sup>	(395 ... 435 VΔ) <sup>1)</sup>		
		see "Selection and ordering data" for outputs at 60 Hz									
		<b>22</b>	<b>34</b>	<b>27</b>	<b>40</b>	<b>21</b>	<b>33</b>	<b>23</b>	<b>35</b>		
1LE1001-1A...-□...-Z F90	100 L	○	○	○	○	✓	✓	✓	✓		
1LE1001-1B...-□...-Z F90	112 M	○	○	○	○	✓	✓	✓	✓		
1LE1001-1C...-□...-Z F90	132 S/M	○	○	○	○	✓	✓	✓	✓		
1LE1001-1D...-□...-Z F90	160 M/L	○	○	○	○	✓	✓	✓	✓		

- Without additional charge  
 ✓ With additional charge

Order other voltages with voltage code **9** in position 12, code **0** in position 13 and the corresponding order code (see "Special versions" in the "Selection and ordering data" under "Voltages", Page 1/54).

Motor type	Frame size	Position 14: Types of construction (type letter)										
		Without flange						With flange (acc. to DIN EN 50347)				
		IM B3 <sup>2)3)</sup>	IM B6 <sup>3)</sup>	IM B7 <sup>3)</sup>	IM B8 <sup>3)</sup>	IM V6 <sup>3)</sup>	IM V5 without protective cover <sup>3)</sup>	Flange size	IM B5 <sup>3)4)</sup>	IM V1 without protective cover <sup>3)</sup>	IM V3 <sup>3)</sup>	IM B35
		A	T	U	V	D	C	F	G	H	J	
		Order No. supplement -Z with order code										
		-	-	-	-	-	-	-	-	-	-	-
1LE1001-1A...-□...-Z F90	100 L	□	□	□	□	□	□	FF 215	✓	✓	✓	✓
1LE1001-1B...-□...-Z F90	112 M	□	□	□	□	□	□	FF 215	✓	✓	✓	✓
1LE1001-1C...-□...-Z F90	132 S/M	□	□	□	□	□	□	FF 265	✓	✓	✓	✓
1LE1001-1D...-□...-Z F90	160 M/L	□	□	□	□	□	□	FF 300	✓	✓	✓	✓

Motor type	Frame size	Position 14: Types of construction (type letter)									
		With standard flange (acc. to DIN EN 50347)					With standard flange (next larger standard flange acc. to DIN EN 50347)				
		Flange size <sup>3)</sup>	IM B14 <sup>3)5)</sup>	IM V19 <sup>3)</sup>	IM V18 without protective cover <sup>3)</sup>	IM B34	Flange size	IM B14 <sup>3)5)</sup>	IM V19 <sup>3)</sup>	IM V18 without protective cover <sup>3)</sup>	IM B34
		K	L	M	N	K	L	M	N		
		Order No. supplement -Z with order code									
		-	-	-	-	-Z	-Z	-Z	-Z	-	-
1LE1001-1A...-□...-Z F90	100 L	FT 130	✓	✓	✓	✓	FT 165	✓	✓	✓	✓
1LE1001-1B...-□...-Z F90	112 M	FT 130	✓	✓	✓	✓	FT 165	✓	✓	✓	✓
1LE1001-1C...-□...-Z F90	132 S/M	FT 165	✓	✓	✓	✓	FT 215	✓	✓	✓	✓
1LE1001-1D...-□...-Z F90	160 M/L	FT 215	✓	✓	✓	✓	-	-	-	-	-

- Standard version  
 ✓ With extra price

- 1) A rated voltage range is also specified on the rating plate.  
 2) The types of construction IM B6/7/8, IM V6 and IM V5 without protective cover are also possible as long as no condensation drainage holes (order code **H03**) and no stamping of these types of construction on the rating plate are required. As standard, the type of construction IM B3 is then stamped on the rating plate.  
 3) The type of construction is stamped on the rating plate. When ordering with condensation drainage holes (order code **H03**), it is absolutely necessary to specify the type of construction for the exact position of the condensation drainage holes during manufacture.

- 4) The types of construction IM V3 and IM V1 without protective cover are also possible as long as no condensation drainage holes (order code **H03**) and no stamping of these types of construction on the rating plate are required. As standard, the type of construction IM B5 is then stamped on the rating plate.  
 5) The types of construction IM V19 and IM V18 without protective cover are also possible as long as no condensation drainage holes (order code **H03**) and no stamping of these types of construction on the rating plate are required. As standard, the type of construction IM B14 is then stamped on the rating plate.

# IEC Squirrel-Cage Motors

## New Generation 1LE1/1PC1

Forced-air cooled motors without external fan and fan cover with high efficiency

### Selection and ordering data (continued)

Motor type	Frame size	Position 15: Motor protection (motor protection letter)					
		Without motor protection	Motor protection with PTC thermistors with 3 embedded temperature sensors for tripping <sup>1)</sup>	Motor protection with PTC thermistors with 6 embedded temperature sensors for alarm and tripping <sup>1)</sup>	Motor temperature detection with embedded temperature sensor KTY 84-130 <sup>1)</sup>	NTC thermistors for tripping	Temperature detectors for tripping <sup>1)</sup>
Order code		A	B	C	F	Z Q2A	Z Q3A
1LE1001-1A...-Q-Z F90	100 L	☐	✓	✓	✓	✓	✓
1LE1001-1B...-Q-Z F90	112 M	☐	✓	✓	✓	✓	✓
1LE1001-1C...-Q-Z F90	132 S/M	☐	✓	✓	✓	✓	✓
1LE1001-1D...-Q-Z F90	160 M/L	☐	✓	✓	✓	✓	✓

- ☐ Standard version  
 ✓ With additional charge

Motor type	Frame size	Position 16: Connection box (connection box code)			
		Connection box top <sup>2)</sup>	Connection box on RHS <sup>3)</sup>	Connection box on LHS <sup>3)</sup>	Connection box bottom <sup>3)</sup>
		4	5	6	7
1LE1001-1A ...-Q-Z F90	100 L	☐	✓	✓	✓
1LE1001-1B ...-Q-Z F90	112 M	☐	✓	✓	✓
1LE1001-1C ...-Q-Z F90	132 S/M	☐	✓	✓	✓
1LE1001-1D ...-Q-Z F90	160 M/L	☐	✓	✓	✓

- ☐ Standard version  
 ✓ With additional charge

<sup>1)</sup> Evaluation with appropriate tripping unit (see Catalog LV 1) is recommended.  
<sup>2)</sup> With type of construction, cast feet as standard. Screwed-on feet are available with order code **H01**, see "Special versions".  
<sup>3)</sup> With type of construction, screwed-on feet as standard.

# IEC Squirrel-Cage Motors

## New Generation 1LE1/1PC1

Self-cooled motors without external fan and fan cover with improved efficiency

### Selection and ordering data

Rated output at		Frame size	Operating values at rated output							Order No.	Price	Weight
50 Hz	60 Hz		Rated speed at 50 Hz	Rated torque at 50 Hz	Efficiency Class according to CEMEP	Efficiency at 50 Hz 4/4-load	Efficiency at 50 Hz 3/4-load	Power factor at 50 Hz 4/4-load	Rated current at 400 V, 50 Hz			
$P_{\text{rated}}$ kW	$P_{\text{rated}}$ kW	FS	$n_{\text{rated}}$ rpm	$T_{\text{rated}}$ Nm	$\eta_{\text{rated}}$ %	$\eta_{\text{rated}}$ %	$\cos\phi_{\text{rated}}$	$I_{\text{rated}}$ A	For Order No. supplements for voltage, type of construction, motor protection and connection box, see from Page 1/48	IM B3 type of construction	IM B3 type of construction approx.  $m$ kg	
<b>Motor version: temperature class 155 (F), IP55 degree of protection, used acc. to temperature class 130 (B)</b>												
<b>2-pole – 3000 rpm at 50 Hz, 3600 rpm at 60 Hz</b>												
1.2		100 L	2830	4.05		81.4		0.92	2.3	<b>1PC1002-1AA4Q-0000</b>	20	
1.6		112 M	2925	5.2		83.6		0.93	2.95	<b>1PC1002-1BA2Q-0000</b>	25	
2.2		132 S	2910	7.24		84		0.94	4	<b>1PC1002-1CA0Q-0000</b>	35	
3		132 S	2920	9.8		87		0.93	5.35	<b>1PC1002-1CA1Q-0000</b>	40	
4.4		160 M	2830	15		89.6		0.9	7.9	<b>1PC1002-1DA2Q-0000</b>	60	
6		160 M	2935	20		90		0.91	10.6	<b>1PC1002-1DA3Q-0000</b>	68	
7.4		160 L	2930	24		90.6		0.92	12.9	<b>1PC1002-1DA4Q-0000</b>	78	
<b>4-pole – 1500 rpm at 50 Hz, 1800 rpm at 60 Hz</b>												
0.88		100 L	1420	5.92		80.7		0.88	1.8	<b>1PC1002-1AB4Q-0000</b>	18	
1.2		100 L	1420	8.06		83		0.89	2.35	<b>1PC1002-1AB5Q-0000</b>	22	
1.6		112 M	1430	11		83.7		0.89	3.1	<b>1PC1002-1BB2Q-0000</b>	27	
2.2		132 S	1450	14.53		85.8		0.89	4.15	<b>1PC1002-1CB0Q-0000</b>	38	
3		132 M	1450	19.8		87.2		0.89	5.58	<b>1PC1002-1CB2Q-0000</b>	44	
4.4		160 M	1460	29		88		0.88	8.2	<b>1PC1002-1DB2Q-0000</b>	62	
6		160 L	1460	39		89.5		0.89	10.9	<b>1PC1002-1DB4Q-0000</b>	73	
<b>6-pole – 1000 rpm at 50 Hz, 1200 rpm at 60 Hz</b>												
0.6		100 L	935	6.12		76.1		0.81	1.4	<b>1PC1002-1AC4Q-0000</b>	19	
0.88		112 M	930	9		79		0.82	1.96	<b>1PC1002-1BC2Q-0000</b>	25	
1.2		132 S	950	12		80.7		0.83	2.58	<b>1PC1002-1CC0Q-0000</b>	34	
1.6		132 M	950	16		83.2		0.83	3.35	<b>1PC1002-1CC2Q-0000</b>	39	
2.2		132 M	950	22.13		85.1		0.83	4.5	<b>1PC1002-1CC3Q-0000</b>	48	
3		160 M	970	30		86.5		0.81	6.2	<b>1PC1002-1DC2Q-0000</b>	72	
4.4		160 L	970	43		88		0.81	8.9	<b>1PC1002-1DC4Q-0000</b>	92	
<b>8-pole – 750 rpm at 50 Hz, 900 rpm at 60 Hz</b>												
0.3		100 L	710	4.05		66.3		0.67	0.97	<b>1PC1002-1AD4Q-0000</b>	17	
0.44		100 L	705	6		71		0.69	1.3	<b>1PC1002-1AD5Q-0000</b>	22	
0.6		112 M	695	8.2		75.2		0.72	1.6	<b>1PC1002-1BD2Q-0000</b>	25	
0.88		132 S	720	11.66		80.6		0.71	2.2	<b>1PC1002-1CD0Q-0000</b>	37	
1.2		132 M	720	16		81.5		0.72	2.95	<b>1PC1002-1CD2Q-0000</b>	44	
1.6		160 M	730	21		82		0.74	3.8	<b>1PC1002-1DD2Q-0000</b>	60	
2.2		160 M	730	29		85		0.74	5.1	<b>1PC1002-1DD3Q-0000</b>	72	
3		160 L	730	39		86		0.74	6.8	<b>1PC1002-1DD4Q-0000</b>	91	

Order No. supplements, see from Page 1/48.

# IEC Squirrel-Cage Motors

## New Generation 1LE1/1PC1

Self-cooled motors without external fan and fan cover with improved efficiency

### Selection and ordering data (continued)

Order No.	Locked-rotor torque	Locked-rotor current	Breaddown torque	Torque class	Moment of inertia	Noise at rated output	
	with direct starting torque	as multiple of rated current	torque			Measuring-surface sound pressure level at 50 Hz	Sound pressure level at 50 Hz
	$T_{LR}/T_{rated}$	$I_{LR}/I_{rated}$	$T_B/T_{rated}$	CL	$J$ kgm <sup>2</sup>	$L_{pA}$ dB(A)	$L_{WA}$ dB(A)
<b>Motor version: temperature class 155 (F), IP55 degree of protection, used acc. to temperature class 130 (B)</b>							
<b>2-pole – 3000 rpm at 50 Hz, 3600 rpm at 60 Hz</b>							
1PC1002-1AA4□-□□□□	3	6	3	16	0.0034	67	79
1PC1002-1BA2□-□□□□	2.3	7.2	3	13	0.0067	69	81
1PC1002-1CA0□-□□□□	1.7	5.3	2.3	10	0.0127	62	74
1PC1002-1CA1□-□□□□	2	6.3	2.8	13	0.0160	62	74
1PC1002-1DA2□-□□□□	2.1	6.3	2.9	13	0.0297	60	72
1PC1002-1DA3□-□□□□	2.5	7	3.1	16	0.0362	60	72
1PC1002-1DA4□-□□□□	2.5	7	3.1	16	0.0439	60	72
<b>4-pole – 1500 rpm at 50 Hz, 1800 rpm at 60 Hz</b>							
1PC1002-1AB4□-□□□□	2	5.1	2.2	13	0.0059	60	72
1PC1002-1AB5□-□□□□	2.2	5.4	2.4	13	0.0078	60	72
1PC1002-1BB2□-□□□□	1.9	5.4	2.2	13	0.0102	58	70
1PC1002-1CB0□-□□□□	2.2	5.7	2.6	13	0.0186	64	76
1PC1002-1CB2□-□□□□	2.4	6.4	2.7	16	0.0237	64	76
1PC1002-1DB2□-□□□□	2.1	7	2.8	13	0.0439	64	76
1PC1002-1DB4□-□□□□	2.4	7.5	3	16	0.0562	64	76
<b>6-pole – 1000 rpm at 50 Hz, 1200 rpm at 60 Hz</b>							
1PC1002-1AC4□-□□□□	1.8	4.1	2	10	0.0065	59	71
1PC1002-1BC2□-□□□□	2.1	4.2	2.2	13	0.0092	55	67
1PC1002-1CC0□-□□□□	1.7	4.5	2.2	10	0.0167	63	75
1PC1002-1CC2□-□□□□	1.9	4.6	2.2	13	0.0212	63	75
1PC1002-1CC3□-□□□□	2.2	5	2.5	13	0.0274	63	75
1PC1002-1DC2□-□□□□	2.1	6	2.7	13	0.0563	67	79
1PC1002-1DC4□-□□□□	2.1	6.4	2.8	13	0.0780	67	79
<b>8-pole – 750 rpm at 50 Hz, 900 rpm at 60 Hz</b>							
1PC1002-1AD4□-□□□□	1.8	3.3	2.2	10	0.0056	60	72
1PC1002-1AD5□-□□□□	1.8	3.4	2.2	10	0.0078	60	72
1PC1002-1BD2□-□□□□	1.7	3.3	1.9	10	0.0094	63	75
1PC1002-1CD0□-□□□□	1.6	4.2	2.3	10	0.0186	63	75
1PC1002-1CD2□-□□□□	1.7	4.2	2.3	10	0.0237	63	75
1PC1002-1DD2□-□□□□	1.7	4.9	2.3	10	0.0439	63	75
1PC1002-1DD3□-□□□□	1.5	5	2.3	10	0.0562	63	75
1PC1002-1DD4□-□□□□	1.8	5.4	2.5	10	0.0772	63	75

# IEC Squirrel-Cage Motors

## New Generation 1LE1/1PC1

Self-cooled motors without external fan and fan cover with improved efficiency

### Selection and ordering data (continued)

#### Order No. supplements

Motor type	Frame size	Positions 12 and 13: Voltages (voltage codes)							
		Standard voltages				Further voltages			
		50 Hz				50 Hz			
		230 VΔ/400 VY	400 VΔ/690 VY	500 VY	500 VΔ	220 VΔ/380 VY	380 VΔ/660 VY	415 VY	415 VΔ
		60 Hz				Rated voltage range			
		460 VY	460 VΔ			(210 ... 230 VΔ/ 360 ... 400 VY) <sup>1)</sup>	(360 ... 400 VΔ/ 625 ... 695 VY) <sup>1)</sup>	(395 ... 435 VY)	(395 ... 435 VΔ)
		see "Selection and ordering data" for outputs at 60 Hz							
		<b>22</b>	<b>34</b>	<b>27</b>	<b>40</b>	<b>21</b>	<b>33</b>	<b>23</b>	<b>35</b>
1PC1002-1A...-□...-	100 L	○	○	○	○	✓	✓	✓	✓
1PC1002-1B...-□...-	112 M	○	○	○	○	✓	✓	✓	✓
1PC1002-1C...-□...-	132 S/M	○	○	○	○	✓	✓	✓	✓
1PC1002-1D...-□...-	160 M/L	○	○	○	○	✓	✓	✓	✓

- Without additional charge  
✓ With additional charge

Order other voltages with voltage code **9** in position 12, code **0** in position 13 and the corresponding order code (see "Special versions" in the "Selection and ordering data" under "Voltages", Page 1/54).

Motor type	Frame size	Position 14: Type of construction (type letter)										
		With flange						With flange (acc. to DIN EN 50347)				
		IM B3 <sup>2)3)</sup>	IM B6 <sup>3)</sup>	IM B7 <sup>3)</sup>	IM B8 <sup>3)</sup>	IM V6 <sup>3)</sup>	IM V5 without protective cover <sup>3)</sup>	Flange size	IM B5 <sup>3)4)</sup>	IM V1 without protective cover <sup>3)</sup>	IM V3 <sup>3)</sup>	IM B35
		<b>A</b>	<b>T</b>	<b>U</b>	<b>V</b>	<b>D</b>	<b>C</b>		<b>F</b>	<b>G</b>	<b>H</b>	<b>J</b>
		Order No. supplement -Z with order code										
1PC1002-1A...-□...-	100 L	□	□	□	□	□	□	FF 215	✓	✓	✓	✓
1PC1002-1B...-□...-	112 M	□	□	□	□	□	□	FF 215	✓	✓	✓	✓
1PC1002-1C...-□...-	132 S/M	□	□	□	□	□	□	FF 265	✓	✓	✓	✓
1PC1002-1D...-□...-	160 M/L	□	□	□	□	□	□	FF 300	✓	✓	✓	✓

Motor type	Frame size	Position 14: Type of construction (type letter)									
		With standard flange (acc. to DIN EN 50347)					With standard flange (next larger standard flange acc. to DIN EN 50347)				
		Flange size	IM B14 <sup>3)5)</sup>	IM V19 <sup>3)</sup>	IM V18 without protective cover <sup>3)</sup>	IM B34	Flange size	IM B14 <sup>3)5)</sup>	IM V19 <sup>3)</sup>	IM V18 without protective cover <sup>3)</sup>	IM B34
			<b>K</b>	<b>L</b>	<b>M</b>	<b>N</b>		<b>K</b>	<b>L</b>	<b>M</b>	<b>N</b>
		Order No. supplement -Z with order code									
			-	-	-	-		<b>-Z</b>	<b>-Z</b>	<b>-Z</b>	<b>-Z</b>
			<b>P01</b>	<b>P01</b>	<b>P01</b>	<b>P01</b>		<b>P01</b>	<b>P01</b>	<b>P01</b>	<b>P01</b>
1PC1002-1A...-□...-	100 L	FT 130	✓	✓	✓	✓	FT 165	✓	✓	✓	✓
1PC1002-1B...-□...-	112 M	FT 130	✓	✓	✓	✓	FT 165	✓	✓	✓	✓
1PC1002-1C...-□...-	132 S/M	FT 165	✓	✓	✓	✓	FT 215	✓	✓	✓	✓
1PC1002-1D...-□...-	160 M/L	FT 215	✓	✓	✓	✓	-	-	-	-	-

- Standard version  
✓ With additional charge

- A rated voltage range is also specified on the rating plate.
- The types of construction IM B6/7/8, IM V6 and IM V5 without protective cover are also possible as long as no condensation drainage holes (order code **H03**) and no stamping of these types of construction on the rating plate are required. As standard, the type of construction IM B3 is then stamped on the rating plate.
- The type of construction is stamped on the rating plate. When ordering with condensation drainage holes (order code **H03**), it is absolutely necessary to specify the type of construction for the exact position of the condensation drainage holes during manufacture.

- The types of construction IM V3 and IM V1 without protective cover are also possible as long as no condensation drainage holes (order code **H03**) and no stamping of these types of construction on the rating plate are required. As standard, the type of construction IM B5 is then stamped on the rating plate.
- The types of construction IM V19 and IM V18 without protective cover are also possible as long as no condensation drainage holes (order code **H03**) and no stamping of these types of construction on the rating plate are required. As standard, the type of construction IM B14 is then stamped on the rating plate.

# IEC Squirrel-Cage Motors

## New Generation 1LE1/1PC1

Self-cooled motors without external fan and fan cover with improved efficiency

### Selection and ordering data (continued)

Motor type	Frame size	Position 15: Motor protection (motor protection letter)					
		Without motor protection	Motor protection with PTC thermistors with 3 embedded temperature sensors for tripping <sup>1)</sup>	Motor protection with PTC thermistors with 6 embedded temperature sensors for alarm and tripping <sup>1)</sup>	Motor temperature detection with embedded temperature sensor KTY 84-130 <sup>1)</sup>	NTC thermistors for tripping	Temperature detectors for tripping <sup>1)</sup>
	Order code	A	B	C	F	Z Q2A	Z Q3A
1PC1002-1A...-...□	100 L	□	✓	✓	✓	✓	✓
1PC1002-1B...-...□	112 M	□	✓	✓	✓	✓	✓
1PC1002-1C...-...□	132 S/M	□	✓	✓	✓	✓	✓
1PC1002-1D...-...□	160 M/L	□	✓	✓	✓	✓	✓

- Standard version  
 ✓ With additional charge

Motor type	Frame size	Position 16: Connection box (connection box code)			
		Connection box top <sup>2)</sup>	Connection box on RHS <sup>3)</sup>	Connection box on LHS <sup>3)</sup>	Connection box bottom <sup>3)</sup>
		4	5	6	7
1PC1002-1A...-...□	100 L	□	✓	✓	✓
1PC1002-1B...-...□	112 M	□	✓	✓	✓
1PC1002-1C...-...□	132 S/M	□	✓	✓	✓
1PC1002-1D...-...□	160 M/L	□	✓	✓	✓

- Standard version  
 ✓ With additional charge

<sup>1)</sup> Evaluation with appropriate tripping unit (see Catalog LV 1) is recommended.  
<sup>2)</sup> With type of construction, cast feet as standard. Screwed-on feet are available with order code **H01**, see "Special versions".  
<sup>3)</sup> With type of construction, screwed-on feet as standard.

# IEC Squirrel-Cage Motors

## New Generation 1LE1/1PC1

Self-cooled motors without external fan and fan cover with high efficiency

### Selection and ordering data

Rated output at		Frame size	Operating values at rated output							Order No.	Price	Weight
50 Hz	60 Hz		Rated speed at 50 Hz	Rated torque at 50 Hz	Efficiency Class according to CEMEP	Efficiency at 50 Hz 4/4-load	Efficiency at 50 Hz 3/4-load	Power factor at 50 Hz 4/4-load	Rated current at 400 V, 50 Hz			
$P_{\text{rated}}$ kW	$P_{\text{rated}}$ kW	FS	$n_{\text{rated}}$ rpm	$T_{\text{rated}}$ Nm	$\eta_{\text{rated}}$ %	$\eta_{\text{rated}}$ %	$\cos\phi_{\text{rated}}$	$I_{\text{rated}}$ A	For Order No. supplements for voltage, type of construction, motor protection and connection box, see from Page 1/52	IM B3 type of construction	IM B3 type of construction approx.  m kg	
<b>Motor version: temperature class 155 (F), IP55 degree of protection, used acc. to temperature class 130 (B)</b>												
<b>2-pole – 3000 rpm at 50 Hz, 3600 rpm at 60 Hz</b>												
1.4		100 L	2920	4.6		87.5		0.88	2.6	<b>1PC1001-1AA4Q-0000</b>	21	
1.6		112 M	2955	5.2		82		0.9	3.15	<b>1PC1001-1BA2Q-0000</b>	27	
3.1		132 S	2955	10		91		0.89	5.5	<b>1PC1001-1CA0Q-0000</b>	39	
4.3		132 S	2955	14		91.5		0.9	7.5	<b>1PC1001-1CA1Q-0000</b>	43	
6.3		160 M	2955	20		94.5		0.89	10.8	<b>1PC1001-1DA2Q-0000</b>	67	
6.5		160 M	2960	21		91.5		0.9	11.4	<b>1PC1001-1DA3Q-0000</b>	75	
9		160 L	2960	29		93.5		0.91	15.2	<b>1PC1001-1DA4Q-0000</b>	84	
<b>4-pole – 1500 rpm at 50 Hz, 1800 rpm at 60 Hz</b>												
1.1		100 L	1460	7.2		86		0.83	2.2	<b>1PC1001-1AB4Q-0000</b>	21	
1.5		100 L	1460	9.8		86		0.84	3	<b>1PC1001-1AB5Q-0000</b>	25	
2		112 M	1460	13		88.5		0.83	3.95	<b>1PC1001-1BB2Q-0000</b>	29	
2.6		132 S	1465	17		89.5		0.83	5.1	<b>1PC1001-1CB0Q-0000</b>	42	
4		132 M	1465	26		89.5		0.84	7.7	<b>1PC1001-1CB2Q-0000</b>	49	
6		160 M	1470	39		91		0.87	11	<b>1PC1001-1DB2Q-0000</b>	71	
6.2		160 L	1480	40		91.5		0.86	11.4	<b>1PC1001-1DB4Q-0000</b>	83	
<b>6-pole – 1000 rpm at 50 Hz, 1200 rpm at 60 Hz</b>												
0.85		100 L	960	8.5		85		0.75	1.92	<b>1PC1001-1AC4Q-0000</b>	25	
1.2		112 M	960	12		83.5		0.75	2.75	<b>1PC1001-1BC2Q-0000</b>	29	
1.5		132 S	970	15		86.5		0.77	3.25	<b>1PC1001-1CC0Q-0000</b>	38	
2.5		132 M	970	25		87		0.79	5.3	<b>1PC1001-1CC2Q-0000</b>	43	
2.7		132 M	975	26		88		0.77	5.8	<b>1PC1001-1CC3Q-0000</b>	52	
5		160 M	975	49		89		0.77	10.6	<b>1PC1001-1DC2Q-0000</b>	77	
6.5		160 L	975	64		89.5		0.8	13.2	<b>1PC1001-1DC4Q-0000</b>	93	
<b>8-pole – 750 rpm at 50 Hz, 900 rpm at 60 Hz</b>												
0.37		100 L	730	4.8		72.5		0.58	1.28	<b>1PC1001-1AD4Q-0000</b>	21	
0.55		100 L	720	7.3		73		0.62	1.76	<b>1PC1001-1AD5Q-0000</b>	25	
0.75		112 M	720	9.9		77.5		0.66	2.1	<b>1PC1001-1BD2Q-0000</b>	29	
1.1		132 S	730	14		82.5		0.65	2.95	<b>1PC1001-1CD0Q-0000</b>	41	
1.5		132 M	730	20		84		0.68	3.8	<b>1PC1001-1CD2Q-0000</b>	49	
2.4		160 M	730	31		88.5		0.7	5.6	<b>1PC1001-1DD2Q-0000</b>	69	
3.3		160 M	730	43		88		0.7	7.7	<b>1PC1001-1DD3Q-0000</b>	82	
4.6		160 L	730	60		88		0.7	10.8	<b>1PC1001-1DD4Q-0000</b>	94	

Order No. supplements, see from Page 1/52.



# IEC Squirrel-Cage Motors

## New Generation 1LE1/1PC1

Self-cooled motors without external fan and fan cover with high efficiency

### Selection and ordering data (continued)

Order No.	Locked-rotor torque	Locked-rotor current	Breaddown torque	Torque class	Moment of inertia	Noise at rated output	
	with direct starting torque	as multiple of rated current	torque			Measuring-surface sound pressure level at 50 Hz	Sound pressure level at 50 Hz
	$T_{LR}/T_{rated}$	$I_{LR}/I_{rated}$	$T_B/T_{rated}$	CL	$J$ kgm <sup>2</sup>	$L_{pFA}$ dB(A)	$L_{WA}$ dB(A)
<b>Motor version: temperature class 155 (F), IP55 degree of protection, used acc. to temperature class 130 (B)</b>							
<b>2-pole – 3000 rpm at 50 Hz, 3600 rpm at 60 Hz</b>							
1PC1001-1AA4Q-QQQQ	2.1	8.3	3.6	13	0.0044	67	79
1PC1001-1BA2Q-QQQQ	2.5	9.5	3.5	16	0.0092	69	81
1PC1001-1CA0Q-QQQQ	1.9	7.1	2.9	13	0.0201	62	74
1PC1001-1CA1Q-QQQQ	1.9	7.6	2.9	13	0.0235	62	74
1PC1001-1DA2Q-QQQQ	1.8	7.1	3	10	0.0447	60	72
1PC1001-1DA3Q-QQQQ	2.3	8.7	3.3	13	0.0528	60	72
1PC1001-1DA4Q-QQQQ	2.4	8.7	3.2	16	0.0608	60	72
<b>4-pole – 1500 rpm at 50 Hz, 1800 rpm at 60 Hz</b>							
1PC1001-1AB4Q-QQQQ	2.1	7.6	3.3	13	0.0086	60	72
1PC1001-1AB5Q-QQQQ	2.2	7.8	3.5	13	0.0109	60	72
1PC1001-1BB2Q-QQQQ	2.3	7.4	3.1	13	0.0140	58	70
1PC1001-1CB0Q-QQQQ	2.2	7.5	2.8	13	0.0270	64	76
1PC1001-1CB2Q-QQQQ	2.1	7.3	2.9	13	0.0335	64	76
1PC1001-1DB2Q-QQQQ	1.8	6	2.5	10	0.0649	64	76
1PC1001-1DB4Q-QQQQ	2.6	8.6	3.5	16	0.0828	64	76
<b>6-pole – 1000 rpm at 50 Hz, 1200 rpm at 60 Hz</b>							
1PC1001-1AC4Q-QQQQ	1.7	5.5	2.6	10	0.0113	59	71
1PC1001-1BC2Q-QQQQ	1.7	5.7	2.7	10	0.0139	55	67
1PC1001-1CC0Q-QQQQ	1.4	5.5	2.4	7	0.0237	63	75
1PC1001-1CC2Q-QQQQ	1.4	5.4	2.3	7	0.0292	63	75
1PC1001-1CC3Q-QQQQ	1.9	6.8	3	13	0.0367	63	75
1PC1001-1DC2Q-QQQQ	1.6	6	2.6	10	0.0754	67	79
1PC1001-1DC4Q-QQQQ	1.6	6	2.6	10	0.0975	67	79
<b>8-pole – 750 rpm at 50 Hz, 900 rpm at 60 Hz</b>							
1PC1001-1AD4Q-QQQQ	1.5	4.5	2.7	10	0.0086	60	72
1PC1001-1AD5Q-QQQQ	1.6	4.4	2.5	10	0.0109	60	72
1PC1001-1BD2Q-QQQQ	1.3	4.4	2.4	7	0.0140	63	75
1PC1001-1CD0Q-QQQQ	1.2	4.5	2.1	7	0.0270	63	75
1PC1001-1CD2Q-QQQQ	1.2	4.7	2.3	7	0.0346	63	75
1PC1001-1DD2Q-QQQQ	1.6	4.4	1.8	10	0.0649	63	75
1PC1001-1DD3Q-QQQQ	1.6	4.6	1.8	10	0.0828	63	75
1PC1001-1DD4Q-QQQQ	1.5	4.5	1.8	10	0.0982	63	75

# IEC Squirrel-Cage Motors

## New Generation 1LE1/1PC1

Self-cooled motors without external fan and fan cover with high efficiency

### Selection and ordering data (continued)

#### Order No. supplements

Motor type	Frame size	Positions 12 and 13: Voltages (voltage codes)							
		Standard voltages				Further voltages			
		50 Hz				50 Hz			
		230 VΔ/400 VY	400 VΔ/690 VY	500 VY	500 VΔ	220 VΔ/380 VY	380 VΔ/660 VY	415 VY	415 VΔ
		60 Hz				Rated voltage range			
		460 VY	460 VΔ			(210 ... 230 VΔ/ 360 ... 400 VY) <sup>1)</sup>	(360 ... 400 VΔ/ 625 ... 695 VY) <sup>1)</sup>	(395 ... 435 VY)	(395 ... 435 VΔ)
		see "Selection and ordering data" for outputs at 60 Hz							
		<b>22</b>	<b>34</b>	<b>27</b>	<b>40</b>	<b>21</b>	<b>33</b>	<b>23</b>	<b>35</b>
1PC1001-1A...-□... <sup>1)</sup>	100 L	○	○	○	○	✓	✓	✓	✓
1PC1001-1B...-□... <sup>1)</sup>	112 M	○	○	○	○	✓	✓	✓	✓
1PC1001-1C...-□... <sup>1)</sup>	132 S/M	○	○	○	○	✓	✓	✓	✓
1PC1001-1D...-□... <sup>1)</sup>	160 M/L	○	○	○	○	✓	✓	✓	✓

- Without additional charge  
 ✓ With additional charge

Order other voltages with voltage code **9** in position 12, code **0** in position 13 and the corresponding order code (see "Special versions" in the "Selection and ordering data" under "Voltages", Page 1/54).

Motor type	Frame size	Position 14: Type of construction (type letter)										
		With flange						With flange (acc. to DIN EN 50347)				
		IM B3 <sup>2)3)</sup>	IM B6 <sup>3)</sup>	IM B7 <sup>3)</sup>	IM B8 <sup>3)</sup>	IM V6 <sup>3)</sup>	IM V5 without protective cover <sup>3)</sup>	Flange size	IM B5 <sup>3)4)</sup>	IM V1 without protective cover <sup>3)</sup>	IM V3 <sup>3)</sup>	IM B35
		<b>A</b>	<b>T</b>	<b>U</b>	<b>V</b>	<b>D</b>	<b>C</b>		<b>F</b>	<b>G</b>	<b>H</b>	<b>J</b>
		Order No. supplement <b>-Z</b> with order code										
1PC1001-1A...-□... <sup>1)</sup>	100 L	□	□	□	□	□	□	FF 215	✓	✓	✓	✓
1PC1001-1B...-□... <sup>1)</sup>	112 M	□	□	□	□	□	□	FF 215	✓	✓	✓	✓
1PC1001-1C...-□... <sup>1)</sup>	132 S/M	□	□	□	□	□	□	FF 265	✓	✓	✓	✓
1PC1001-1D...-□... <sup>1)</sup>	160 M/L	□	□	□	□	□	□	FF 300	✓	✓	✓	✓

Motor type	Frame size	Position 14: Type of construction (type letter)									
		With standard flange (acc. to DIN EN 50347)					With standard flange (next larger standard flange acc. to DIN EN 50347)				
		Flange size	IM B14 <sup>3)5)</sup>	IM V19 <sup>3)</sup>	IM V18 without protective cover <sup>3)</sup>	IM B34	Flange size	IM B14 <sup>3)5)</sup>	IM V19 <sup>3)</sup>	IM V18 without protective cover <sup>3)</sup>	IM B34
			<b>K</b>	<b>L</b>	<b>M</b>	<b>N</b>		<b>K</b>	<b>L</b>	<b>M</b>	<b>N</b>
		Order No. supplement <b>-Z</b> with order code									
			<b>-Z</b>	<b>-Z</b>	<b>-Z</b>	<b>-Z</b>		<b>P01</b>	<b>P01</b>	<b>P01</b>	<b>P01</b>
1PC1001-1A...-□... <sup>1)</sup>	100 L	FT 130	✓	✓	✓	✓	FT 165	✓	✓	✓	✓
1PC1001-1B...-□... <sup>1)</sup>	112 M	FT 130	✓	✓	✓	✓	FT 165	✓	✓	✓	✓
1PC1001-1C...-□... <sup>1)</sup>	132 S/M	FT 165	✓	✓	✓	✓	FT 215	✓	✓	✓	✓
1PC1001-1D...-□... <sup>1)</sup>	160 M/L	FT 215	✓	✓	✓	✓	-	-	-	-	-

- Standard version  
 ✓ With additional charge

- A rated voltage range is also specified on the rating plate.
- The types of construction IM B6/7/8, IM V6 and IM V5 without protective cover are also possible as long as no condensation drainage holes (order code **H03**) and no stamping of these types of construction on the rating plate are required. As standard, the type of construction IM B3 is then stamped on the rating plate.
- The type of construction is stamped on the rating plate. When ordering with condensation drainage holes (order code **H03**), it is absolutely necessary to specify the type of construction for the exact position of the condensation drainage holes during manufacture.

- The types of construction IM V3 and IM V1 without protective cover are also possible as long as no condensation drainage holes (order code **H03**) and no stamping of these types of construction on the rating plate are required. As standard, the type of construction IM B5 is then stamped on the rating plate.
- The types of construction IM V19 and IM V18 without protective cover are also possible as long as no condensation drainage holes (order code **H03**) and no stamping of these types of construction on the rating plate are required. As standard, the type of construction IM B14 is then stamped on the rating plate.

# IEC Squirrel-Cage Motors

## New Generation 1LE1/1PC1

Self-cooled motors without external fan and fan cover with high efficiency

### Selection and ordering data (continued)

Motor type	Frame size	Position 15: Motor protection (motor protection letter)					
		Without motor protection	Motor protection with PTC thermistors with 3 embedded temperature sensors for tripping <sup>1)</sup>	Motor protection with PTC thermistors with 6 embedded temperature sensors for alarm and tripping <sup>1)</sup>	Motor temperature detection with embedded temperature sensor KTY 84-130 <sup>1)</sup>	NTC thermistors for tripping	Temperature detectors for tripping <sup>1)</sup>
	Order code	A	B	C	F	Z Q2A	Z Q3A
1PC1001-1A...-...□	100 L	□	✓	✓	✓	✓	✓
1PC1001-1B...-...□	112 M	□	✓	✓	✓	✓	✓
1PC1001-1C...-...□	132 S/M	□	✓	✓	✓	✓	✓
1PC1001-1D...-...□	160 M/L	□	✓	✓	✓	✓	✓

- Standard version  
 ✓ With additional charge

Motor type	Frame size	Position 16: Connection box (connection box code)			
		Connection box top <sup>2)</sup>	Connection box on RHS <sup>3)</sup>	Connection box on LHS <sup>3)</sup>	Connection box bottom <sup>3)</sup>
		4	5	6	7
1PC1001-1A...-...□	100 L	□	✓	✓	✓
1PC1001-1B...-...□	112 M	□	✓	✓	✓
1PC1001-1C...-...□	132 S/M	□	✓	✓	✓
1PC1001-1D...-...□	160 M/L	□	✓	✓	✓

- Standard version  
 ✓ With additional charge

<sup>1)</sup> Evaluation with appropriate tripping unit (see Catalog LV 1) is recommended.  
<sup>2)</sup> With type of construction, cast feet as standard. Screwed-on feet are available with order code **H01**, see "Special versions".  
<sup>3)</sup> With type of construction, screwed-on feet as standard.

# IEC Squirrel-Cage Motors

## New Generation 1LE1/1PC1

### Special versions

#### Selection and ordering data

##### Voltages

Additional order codes for other voltages or voltage codes  
(without **-Z** supplement)

Not possible for General Line motors with shorter delivery time.

For some non-standard voltages at 50 or 60 Hz, order codes are specified. They are ordered by specifying the code digit **9** for voltage in the 12th position and **0** in the 13th position of the Order No. and the appropriate order code.

Special versions	Voltage code 12th / 13th position of the Order No.	Additional identi- fication code with order code and plain text if required	Motor type frame size										
			56	63	71	80	90	100	112	132	160		
<b>Self-ventilated energy-saving motors with improved efficiency</b> <b>Self-ventilated energy-saving motors with high efficiency</b> <b>Self-ventilated motors with increased output and improved efficiency</b> <b>Self-ventilated motors with increased output and high efficiency</b> <b>Forced-air cooled motors without external fan and fan cover with improved efficiency</b> <b>Forced-air cooled motors without external fan and fan cover with high efficiency</b> <b>Self-cooled motors without external fan and fan cover with improved efficiency</b> <b>Self-cooled motors without external fan and fan cover with high efficiency</b>													
										<b>1LE1/1PC1 (Aluminum)</b>			
<b>Voltage at 60 Hz</b>													
220 VΔ/380 VY; 50 Hz output	<b>9</b>	<b>0</b>	<b>M2A</b>							✓	✓	✓	✓
220 VΔ/380 VY; 60 Hz output	<b>9</b>	<b>0</b>	<b>M1A</b>							✓	✓	✓	✓
380 VΔ/660 VY; 50 Hz output	<b>9</b>	<b>0</b>	<b>M2B</b>							✓	✓	✓	✓
380 VΔ/660 VY; 60 Hz output	<b>9</b>	<b>0</b>	<b>M1B</b>							✓	✓	✓	✓
440 VY; 50 Hz output	<b>9</b>	<b>0</b>	<b>M2C</b>							✓	✓	✓	✓
440 VY; 60 Hz output	<b>9</b>	<b>0</b>	<b>M1C</b>							✓	✓	✓	✓
440 VΔ; 50 Hz output	<b>9</b>	<b>0</b>	<b>M2D</b>							✓	✓	✓	✓
440 VΔ; 60 Hz output	<b>9</b>	<b>0</b>	<b>M1D</b>							✓	✓	✓	✓
460 VY; 50 Hz output	<b>9</b>	<b>0</b>	<b>M2E</b>							✓	✓	✓	✓
460 VY; 60 Hz output	<b>9</b>	<b>0</b>	<b>M1E</b>							○	○	○	○
460 VΔ; 50 Hz output	<b>9</b>	<b>0</b>	<b>M2F</b>							✓	✓	✓	✓
460 VΔ; 60 Hz output	<b>9</b>	<b>0</b>	<b>M1F</b>							○	○	○	○
575 VY; 50 Hz output	<b>9</b>	<b>0</b>	<b>M2G</b>							✓	✓	✓	✓
575 VY; 60 Hz output	<b>9</b>	<b>0</b>	<b>M1G</b>							✓	✓	✓	✓
575 VΔ; 50 Hz output	<b>9</b>	<b>0</b>	<b>M2H</b>							✓	✓	✓	✓
575 VΔ; 60 Hz output	<b>9</b>	<b>0</b>	<b>M1H</b>							✓	✓	✓	✓
<b>Non-standard voltages and / or frequencies</b>													
Non-standard winding for volt- ages between 200 V and 690 V (voltages outside this range are available on request) <sup>1)</sup>	<b>9</b>	<b>0</b>	<b>M1Y</b>							✓	✓	✓	✓

- Without additional charge  
✓ With additional charge

<sup>1)</sup> Plain text must be specified in the order: voltage, frequency, circuit, required rated output in kW.

# IEC Squirrel-Cage Motors

## New Generation 1LE1/1PC1

**Special versions**

### Options

Options or order codes (supplement **-Z** is required)

Not possible for General Line motors with shorter delivery time.

Special versions	Additional identification code <b>-Z</b> with order code and plain text if required	Motor type frame size									
		56	63	71	80	90	100	112	132	160	
<b>Self-ventilated energy-saving motors with improved efficiency</b>											
<b>Self-ventilated energy-saving motors with high efficiency</b>											
<b>Self-ventilated motors with increased output and improved efficiency</b>											
<b>Self-ventilated motors with increased output and high efficiency</b>											
								<b>1LE1 (Aluminum)</b>			
<b>Motor connection and connection box</b>											
One cable gland, metal	<b>R15</b>							✓	✓	✓	✓
Rotation of the connection box through 90°, entry from DE	<b>R10</b>							○	○	○	○
Rotation of the connection box through 90°, entry from NDE	<b>R11</b>							○	○	○	○
Rotation of the connection box through 180°	<b>R12</b>							○	○	○	○
Larger connection box	<b>R50</b>							✓	✓	✓	✓
Reduction piece for M cable gland in accordance with British standard, both cable entries mounted	<b>R30</b>							✓	✓	✓	✓
External earthing	<b>H04</b>							✓	✓	✓	✓
3 cables protruding, 0.5 m long <sup>2)3)</sup>	<b>R20</b>							✓	✓	✓	✓
3 cables protruding, 1.5 m long <sup>2)3)</sup>	<b>R21</b>							✓	✓	✓	✓
6 cables protruding, 0.5 m long <sup>2)</sup>	<b>R22</b>							✓	✓	✓	✓
6 cables protruding, 1.5 m long <sup>2)</sup>	<b>R23</b>							✓	✓	✓	✓
6 cables protruding, 3 m long <sup>2)</sup>	<b>R24</b>							✓	✓	✓	✓
Connection box on NDE <sup>4)</sup>	<b>H08</b>							✓	✓	✓	✓
<b>Windings and insulation</b>											
Temperature class 155 (F), used acc. to 155 (F), with service factor (SF)	<b>N01</b>							✓	✓	✓	✓
Temperature class 155 (F), used acc. to 155 (F), with increased output	<b>N02</b>							✓	✓	✓	✓
Temperature class 155 (F), used acc. to 155 (F), with increased coolant temperature	<b>N03</b>							✓	✓	✓	✓
Temperature class 180 (H) at rated power and max. CT 60 °C <sup>5)</sup>	<b>N11</b>							✓	✓	✓	✓
Increased air humidity/temperature with 30 to 60 g water per m <sup>3</sup> of air	<b>N20</b>							✓	✓	✓	✓
Temperature class 155 (F), used acc. to 130 (B), coolant temperature 45 °C, derating approx. 4 %	<b>N05</b>							✓	✓	✓	✓

# IEC Squirrel-Cage Motors

## New Generation 1LE1/1PC1

### Special versions

Special versions	Additional identification code <b>-Z</b> with order code and plain text if required	Motor type frame size								
		56	63	71	80	90	100	112	132	160
<b>Self-ventilated energy-saving motors with improved efficiency</b> <b>Self-ventilated energy-saving motors with high efficiency</b> <b>Self-ventilated motors with increased output and improved efficiency</b> <b>Self-ventilated motors with increased output and high efficiency</b>										
<b>1LE1 (Aluminum)</b>										
<b>Windings and insulation (continued)</b>										
Temperature class 155 (F), used acc. to 130 (B), coolant temperature 50 °C, derating approx. 8 %	<b>N06</b>						✓	✓	✓	✓
Temperature class 155 (F), used acc. to 130 (B), coolant temperature 55 °C, derating approx. 13 %	<b>N07</b>						✓	✓	✓	✓
Temperature class 155 (F), used acc. to 130 (B), coolant temperature 60 °C, derating approx. 18 %	<b>N08</b>						✓	✓	✓	✓
Increased air humidity/temperature with 60 to 100 g water per m <sup>3</sup> of air	<b>N21</b>						✓	✓	✓	✓
Temperature class 155 (F), used acc. to 155 (F), other requirements	<b>Y52 •</b> and identification code						✓	✓	✓	✓
<b>Colors and paint finish</b>										
Special finish in RAL 7030 stone gray							□	□	□	□
Special finish in other standard RAL colors : RAL 1002, 1013, 1015, 1019, 2003, 2004, 3000, 3007, 5007, 5009, 5010, 5012, 5015, 5017, 5018, 5019, 6011, 6019, 6021, 7000, 7001, 7004, 7011, 7016, 7022, 7031, 7032, 7033, 7035, 9001, 9002, 9005, Page 0/101	<b>Y54 •</b> and special finish RAL....						✓	✓	✓	✓
Special finish in special RAL colors: for RAL colors, see "Special finish in special RAL colors", Page 0/101	<b>Y51 •</b> and special finish RAL....						✓	✓	✓	✓
Special finish sea air resistant	<b>S03</b>						O. R.	O. R.	O. R.	O. R.
Unpainted (only cast iron parts primed)	<b>S00</b>						○	○	○	○
Unpainted, only primed	<b>S01</b>						✓	✓	✓	✓
<b>Modular technology – Basic versions <sup>6)</sup></b>										
Mounting of separately driven fan	<b>F70</b>						✓	✓	✓	✓
Mounting of brake <sup>7)</sup>	<b>F01</b>						✓	✓	✓	✓
Mounting of 1XP8012-10 (HTL) rotary pulse encoder <sup>8)</sup>	<b>G01</b>						✓	✓	✓	✓
Mounting of 1XP8012-20 (TTL) rotary pulse encoder <sup>8)</sup>	<b>G02</b>						✓	✓	✓	✓
<b>Modular technology – Additional versions</b>										
Brake supply voltage 24 V DC	<b>F10</b>						✓	✓	✓	✓
Brake supply voltage 230 V AC, 50/60 Hz	<b>F11</b>						○	○	○	○
Brake supply voltage 400 V AC, 50/60 Hz	<b>F12</b>						✓	✓	✓	✓
Mechanical manual brake release with lever (no locking)	<b>F50</b>						✓	✓	✓	✓

For legend and footnotes, see Page 1/59.

# IEC Squirrel-Cage Motors

## New Generation 1LE1/1PC1

### Special versions

Special versions	Additional identification code <b>-Z</b> with order code and plain text if required	Motor type frame size											
		56	63	71	80	90	100	112	132	160			
<b>Self-ventilated energy-saving motors with improved efficiency</b> <b>Self-ventilated energy-saving motors with high efficiency</b> <b>Self-ventilated motors with increased output and improved efficiency</b> <b>Self-ventilated motors with increased output and high efficiency</b>													
										<b>1LE1 (Aluminum)</b>			
<b>Special technology <sup>6)</sup></b>													
Mounting of LL 861 900 220 rotary pulse encoder <sup>8)</sup>	<b>G04</b>									✓	✓	✓	✓
Mounting of HOG 9 D 1024 I rotary pulse encoder <sup>8)</sup>	<b>G05</b>									✓	✓	✓	✓
Mounting of HOG 10 D 1024 I rotary pulse encoder <sup>8)</sup>	<b>G06</b>									✓	✓	✓	✓
<b>Mechanical design and degrees of protection</b>													
Protective cover for types of construction <sup>8)</sup>	<b>H00</b>									✓	✓	✓	✓
Screwed-on feet (instead of cast)	<b>H01</b>									✓	✓	✓	✓
Radial seal on DE for flange-mounting motors with oil resistance to 0.1 bar <sup>9)</sup>	<b>H23</b>									✓	✓	✓	✓
Low-noise version for 2-pole motors with clockwise direction of rotation	<b>F77</b>									–	–	✓	✓
Low-noise version for 2-pole motors with counter-clockwise direction of rotation	<b>F78</b>									–	–	✓	✓
IP65 degree of protection <sup>10)</sup>	<b>H20</b>									✓	✓	✓	✓
IP56 degree of protection (non-heavy-sea) <sup>11)</sup>	<b>H22</b>									✓	✓	✓	✓
Vibration-proof version	<b>H02</b>									✓	✓	✓	✓
Condensation drainage holes <sup>12)</sup>	<b>H03</b>									✓	✓	✓	✓
Non-rusting screws (externally)	<b>H07</b>									✓	✓	✓	✓
Prepared for mountings, only center hole <sup>13)</sup>	<b>G40</b>									✓	✓	✓	✓
Prepared for mountings with D12 shaft <sup>13)</sup>	<b>G41</b>									✓	✓	✓	✓
Prepared for mountings with D16 shaft <sup>13)</sup>	<b>G42</b>									✓	✓	✓	✓
Protective cover for encoder (loosely enclosed – only for mountings acc. to order codes G40, G41 and G42)	<b>G43</b>									✓	✓	✓	✓
<b>Coolant temperature and site altitude</b>													
Coolant temperature –40 °C to +40 °C <sup>14)</sup>	<b>D03</b>									✓	✓	✓	✓
Coolant temperature –30 °C to +40 °C <sup>14)</sup>	<b>D04</b>									✓	✓	✓	✓
<b>Designs in accordance with standards and specifications</b>													
Electrical according to NEMA MG1-12 <sup>15)</sup>	<b>D30</b>									✓	✓	✓	✓
Design according to UL with "Recognition Mark" <sup>16)</sup>	<b>D31</b>									✓	✓	✓	✓
Canadian regulations (CSA) <sup>17)</sup>	<b>D40</b>									✓	✓	✓	✓
PSE Mark Japan <sup>18)</sup>	<b>D46</b>									✓	✓	✓	–

# IEC Squirrel-Cage Motors

## New Generation 1LE1/1PC1

### Special versions

Special versions	Additional identification code <b>-Z</b> with order code and plain text if required	Motor type frame size								
		56	63	71	80	90	100	112	132	160
<b>Self-ventilated energy-saving motors with improved efficiency</b> <b>Self-ventilated energy-saving motors with high efficiency</b> <b>Self-ventilated motors with increased output and improved efficiency</b> <b>Self-ventilated motors with increased output and high efficiency</b>										
<b>1LE1 (Aluminum)</b>										
<b>Bearings and lubrication</b>										
Measuring nipple for SPM shock pulse measurement for bearing inspection <sup>19)</sup>	<b>Q01</b>						✓	✓	✓	✓
Bearing design for increased cantilever forces	<b>L22</b>						✓	✓	✓	✓
Special bearing for DE and NDE, bearing size 63	<b>L25</b>						✓	✓	✓	✓
Regreasing device <sup>19)</sup>	<b>L23</b>						✓	✓	✓	✓
Located bearing at DE	<b>L20</b>						✓	✓	✓	✓
Located bearing at NDE	<b>L21</b>						✓	✓	✓	□
<b>Balance and vibration quantity</b>										
Vibration quantity A							□	□	□	□
Vibration quantity B	<b>L00</b>						✓	✓	✓	✓
Half-key balancing (standard)							□	□	□	□
Full-key balancing	<b>L02</b>						✓	✓	✓	✓
Balancing without key	<b>L01</b>						✓	✓	✓	✓
<b>Shaft and rotor</b>										
Concentricity of shaft extension, coaxiality and linear movement in accordance with DIN 42955 Tolerance R for flange-mounting motors	<b>L08</b>						✓	✓	✓	✓
Second standard shaft extension	<b>L05</b>						✓	✓	✓	✓
Shaft extension with standard dimensions, without featherkey way	<b>L04</b>						✓	✓	✓	✓
Concentricity of shaft extension in accordance with DIN 42955 Tolerance R	<b>L07</b>						✓	✓	✓	✓
Standard shaft made of non-rusting steel	<b>L06</b>						✓	✓	✓	✓
Non-standard cylindrical shaft extension <sup>20)</sup>	<b>Y55 •</b> and identification code						✓	✓	✓	✓
<b>Heating and ventilation</b>										
Fan cover for textile industry	<b>F75</b>						✓	✓	✓	✓
Metal external fan <sup>21)</sup>	<b>F76</b>						✓	✓	✓	✓
Anti-condensation heaters for 230 V	<b>Q02</b>						✓	✓	✓	✓
Anti-condensation heaters for 115 V	<b>Q03</b>						✓	✓	✓	✓
Sheet metal fan cover	<b>F74</b>						✓	✓	✓	✓
<b>Rating plate and extra rating plates</b>										
Second rating plate, loose	<b>M10</b>						✓	✓	✓	✓
Nirosta rating plate	<b>M11</b>						✓	✓	✓	✓
Extra rating plate or rating plate with deviating rating plate data	<b>Y80 •</b> and identification code						✓	✓	✓	✓
Extra rating plate with identification codes	<b>Y82 •</b> and identification code						✓	✓	✓	✓
Additional information on rating plate and on package label (max. of 20 characters)	<b>Y84 •</b> and identification code						✓	✓	✓	✓

For legend and footnotes, see Page 1/59.



# IEC Squirrel-Cage Motors

## New Generation 1LE1/1PC1

### Special versions

Special versions	Additional identification code <b>-Z</b> with order code and plain text if required	Motor type frame size										
		56	63	71	80	90	100	112	132	160		
Self-ventilated energy-saving motors with improved efficiency												
Self-ventilated energy-saving motors with high efficiency												
Self-ventilated motors with increased output and improved efficiency												
Self-ventilated motors with increased output and high efficiency												
								<b>1LE1 (Aluminum)</b>				
<b>Packaging, safety notes, documentation and test certificates</b>												
Without safety and commissioning note. Customer's declaration of renouncement required.	<b>B00</b>								○	○	○	○
With one safety and start-up guide per box pallet	<b>B01</b>								○	○	○	○
Acceptance test certificate 3.1 in accordance with EN 10204	<b>B02</b>								✓	✓	✓	✓
Printed operating instructions English/German enclosed	<b>B04</b>								✓	✓	✓	✓
Type test with heat run for horizontal motors, with acceptance	<b>B83</b>								✓	✓	✓	✓
Wire-lattice pallet	<b>B99</b>								○	○	○	○
Connected in star for dispatch	<b>M01</b>								✓	✓	✓	✓
Connected in delta for dispatch	<b>M02</b>								✓	✓	✓	✓

- Standard version
- Without additional charge
- This order code only determines the price of the version – Additional plain text is required.
- R. Available on request
- ✓ With additional charge

- 1) Not possible in combination with order code **R15** "One cable gland, metal".
- 2) In combination with motor protection (position 15 of the Order No.) or with option anti-condensation heater request required.
- 3) Not possible in combination with voltage code **22** or **34**.
- 4) Not possible in combination with the following order codes: **N01, N02, N03, N05, N06, N07, N08, N11**.  
Use according to temperature class 155 (F) possible only.
- 5) Cannot be used for motors in UL version (order code **D31**). The grease lifetime specified in catalog part 0 "Introduction" refers to CT 40 °C. When the coolant temperature rises by 10 K, the grease lifetime or relubrication interval is halved.
- 6) A second shaft extension is not possible. Please inquire for mounted brakes.
- 7) When quoting or ordering, it is necessary to provide the brake supply voltage for order codes **F10, F11** and **F12**.
- 8) All encoders are supplied with a protective cover as standard. The protective cover is not supplied with the combination rotary pulse encoder with separately driven fan, as, in this case, the rotary pulse encoder is installed under the fan cover.
- 9) Not possible for type of construction IM V3.
- 10) Not possible in combination with rotary pulse encoder HOG 9 D 10241 (order code **G05**) and/or brake 2LM8 (order code **F01**).
- 11) Not possible in combination with brake 2LM8 – order code **F01**.
- 12) Supplied with the condensation drainage holes sealed at the drive end (DE) and non-drive end (NDE) (IP55, IP56, IP65). If condensation drainage holes are required for motors with IM B6, IM B7 or IM B8 type of construction (feet located on side or top), it is necessary to order the motors in their respective type of construction and order code **H03**, so that the condensation drainage holes can be mounted in the correct positional arrangement.
- 13) Motors that are prepared for additional mountings (order codes **G40, G41, G42**) are supplied without protective cover as standard. If a protective cover is requested as cover or as mechanical protection for mounting provided by the customer, it can be ordered with order code **G43**.  
Not possible in combination with order code **L00**, vibration quantity level B.
- 14) In connection with mountings, the respective technical data must be observed; request required.
- 15) 1LE1 motors in EFF1 version without additional charge (standard version).
- 16) Possible up to 600 V max. The rated voltage is indicated on the rating plate without voltage range.
- 17) The rated voltage is indicated on the rating plate without voltage range.
- 18) "Small power motors" with a rated output of up to 3 kW which are exported to Japan must bear the PSE marking.
- 19) Not possible when brake is mounted.
- 20) When motors are ordered that have a longer or shorter shaft extension than normal, the required position and length of the featherkey way must be specified in a sketch. It must be ensured that only featherkeys in accordance with DIN 6885, Form A are permitted to be used. The featherkey way is positioned centrally on the shaft extension. The length is defined by the manufacturer normatively. Not valid for: Conical shafts, non-standard threaded journals, non-standard shaft tolerances, friction welded journals, extremely "thin" shafts, special geometry dimensions (e.g. square journals), hollow shafts. Valid for non-standard shaft extensions DE or NDE. The featherkeys are supplied in every case. For order codes **Y55** and **L05**:  
- Dimensions D and DA ≤ internal diameter of roller bearing (see dimension tables under "Dimensions")  
- Dimensions E and EA ≤ 2 x length E (normal) of the shaft extension  
For an explanation of the order codes, see catalog part 0 "Introduction".
- 21) For 1LE1 motors with metal external fan, converter-fed operation is permitted. The metal external fan is not possible in combination with the low-noise version – order code **F77** or **F78**.

# IEC Squirrel-Cage Motors

## New Generation 1LE1/1PC1

### Special versions

Options or order codes (supplement **-Z** is required)

Not possible for General Line motors with shorter delivery time.

Special versions	Additional identification code <b>-Z</b> with order code and plain text if required	Motor type frame size											
		56	63	71	80	90	100	112	132	160			
<b>Forced-air cooled motors without external fan and fan cover with improved efficiency</b>													
<b>Forced-air cooled motors without external fan and fan cover with high efficiency</b>													
<b>Self-cooled motors without external fan and fan cover with improved efficiency</b>													
<b>Self-cooled motors without external fan and fan cover with high efficiency</b>													
<b>1LE1/1PC1 (Aluminum)</b>													
<b>Motor connection and connection box</b>													
One cable gland, metal	<b>R15</b>									✓	✓	✓	✓
Rotation of the connection box through 90°, entry from DE	<b>R10</b>									○	○	○	○
Rotation of the connection box through 90°, entry from NDE	<b>R11</b>									○	○	○	○
Rotation of the connection box through 180°	<b>R12</b>									○	○	○	○
Larger connection box	<b>R50</b>									✓	✓	✓	✓
Reduction piece for M cable gland in accordance with British standard, both cable entries mounted <sup>1)</sup>	<b>R30</b>									✓	✓	✓	✓
External earthing	<b>H04</b>									✓	✓	✓	✓
3 cables protruding, 0.5 m long <sup>2)3)</sup>	<b>R20</b>									✓	✓	✓	✓
3 cables protruding, 1.5 m long <sup>2)3)</sup>	<b>R21</b>									✓	✓	✓	✓
6 cables protruding, 0.5 m long <sup>2)</sup>	<b>R22</b>									✓	✓	✓	✓
6 cables protruding, 1.5 m long <sup>2)</sup>	<b>R23</b>									✓	✓	✓	✓
6 cables protruding, 3 m long <sup>2)</sup>	<b>R24</b>									✓	✓	✓	✓
Connection box on NDE <sup>4)</sup>	<b>H08</b>									✓	✓	✓	✓
<b>Windings and insulation</b>													
Temperature class 155 (F), used acc. to 155 (F), with service factor (SF)	<b>N01</b>									✓	✓	✓	✓
Temperature class 155 (F), used acc. to 155 (F), with increased output	<b>N02</b>									✓	✓	✓	✓
Temperature class 155 (F), used acc. to 155 (F), with increased coolant temperature	<b>N03</b>									✓	✓	✓	✓
Temperature class 180 (H) at rated power and max. CT 60 °C <sup>5)</sup>	<b>N11</b>									✓	✓	✓	✓
Increased air humidity/temperature with 30 to 60 g water per m <sup>3</sup> of air	<b>N20</b>									✓	✓	✓	✓
Temperature class 155 (F), used acc. to 130 (B), coolant temperature 45 °C, derating approx. 4 %	<b>N05</b>									✓	✓	✓	✓

For legend and footnotes, see Page 1/63.

# IEC Squirrel-Cage Motors

## New Generation 1LE1/1PC1

### Special versions

Special versions	Additional identification code <b>-Z</b> with order code and plain text if required	Motor type frame size								
		56	63	71	80	90	100	112	132	160
<b>Forced-air cooled motors without external fan and fan cover with improved efficiency</b>										
<b>Forced-air cooled motors without external fan and fan cover with high efficiency</b>										
<b>Self-cooled motors without external fan and fan cover with improved efficiency</b>										
<b>Self-cooled motors without external fan and fan cover with high efficiency</b>										
<b>1LE1/1PC1 (Aluminum)</b>										
<b>Windings and insulation (continued)</b>										
Temperature class 155 (F), used acc. to 130 (B), coolant temperature 50 °C, derating approx. 8 %	<b>N06</b>						✓	✓	✓	✓
Temperature class 155 (F), used acc. to 130 (B), coolant temperature 55 °C, derating approx. 13 %	<b>N07</b>						✓	✓	✓	✓
Temperature class 155 (F), used acc. to 130 (B), coolant temperature 60 °C, derating approx. 18 %	<b>N08</b>						✓	✓	✓	✓
Increased air humidity/temperature with 60 to 100 g water per m <sup>3</sup> of air	<b>N21</b>						✓	✓	✓	✓
Temperature class 155 (F), used acc. to 155 (F), other requirements	<b>Y52 •</b> and identification code						✓	✓	✓	✓
<b>Colors and paint finish</b>										
Special finish in RAL 7030 stone gray							□	□	□	□
Special finish in other standard RAL colors : RAL 1002, 1013, 1015, 1019, 2003, 2004, 3000, 3007, 5007, 5009, 5010, 5012, 5015, 5017, 5018, 5019, 6011, 6019, 6021, 7000, 7001, 7004, 7011, 7016, 7022, 7031, 7032, 7033, 7035, 9001, 9002, 9005, Page 0/101	<b>Y54 •</b> and special finish RAL....						✓	✓	✓	✓
Special finish in special-RAL colors: for RAL colors, see "Special finish in special RAL colors", Page 0/101	<b>Y51 •</b> and special finish RAL....						✓	✓	✓	✓
Special finish sea air resistant	<b>S03</b>						O. R.	O. R.	O. R.	O. R.
Unpainted (only cast iron parts primed)	<b>S00</b>						○	○	○	○
Unpainted, only primed	<b>S01</b>						✓	✓	✓	✓
<b>Mechanical design and degree of protection</b>										
Screwed-on feet (instead of cast)	<b>H01</b>						✓	✓	✓	✓
Radial seal on DE for flange-mounting motors with oil resistance to 0.1 bar <sup>6)</sup>	<b>H23</b>						✓	✓	✓	✓
IP65 degree of protection	<b>H20</b>						✓	✓	✓	✓
IP56 degree of protection (non-heavy-sea)	<b>H22</b>						✓	✓	✓	✓
Vibration-proof version	<b>H02</b>						✓	✓	✓	✓
Condensation drainage holes <sup>7)</sup>	<b>H03</b>						✓	✓	✓	✓
Non-rusting screws (externally)	<b>H07</b>						✓	✓	✓	✓
<b>Coolant temperature and site altitude</b>										
Coolant temperature -40 °C to +40 °C	<b>D03</b>						✓	✓	✓	✓
Coolant temperature -30 °C to +40 °C	<b>D04</b>						✓	✓	✓	✓

# IEC Squirrel-Cage Motors

## New Generation 1LE1/1PC1

### Special versions

Special versions	Additional identification code <b>-Z</b> with order code and plain text if required	Motor type frame size								
		56	63	71	80	90	100	112	132	160
<b>Forced-air cooled motors without external fan and fan cover with improved efficiency</b>										
<b>Forced-air cooled motors without external fan and fan cover with high efficiency</b>										
<b>Self-cooled motors without external fan and fan cover with improved efficiency</b>										
<b>Self-cooled motors without external fan and fan cover with high efficiency</b>										
<b>1LE1/1PC1 (Aluminum)</b>										
<b>Designs in accordance with standards and specifications</b>										
Electrical according to NEMA MG1-12 <sup>8)</sup>	<b>D30</b>									
Design according to UL with "Recognition Mark" <sup>9)</sup>	<b>D31</b>									
Canadian regulations (CSA) <sup>10)</sup>	<b>D40</b>									
PSE Mark Japan <sup>11)</sup>	<b>D46</b>									
<b>Bearings and lubrication</b>										
Measuring nipple for SPM shock pulse measurement for bearing inspection	<b>Q01</b>									
Bearing design for increased cantilever forces	<b>L22</b>									
Special bearing for DE and NDE, bearing size 63	<b>L25</b>									
Regreasing device	<b>L23</b>									
Located bearing at DE	<b>L20</b>									
Located bearing at NDE	<b>L21</b>									
<b>Balance and vibration quantity</b>										
Vibration quantity A										
Vibration quantity B	<b>L00</b>									
Half-key balancing (standard)										
Full-key balancing	<b>L02</b>									
Balancing without key	<b>L01</b>									
<b>Shaft and rotor</b>										
Concentricity of shaft extension, coaxiality and linear movement in accordance with DIN 42955 Tolerance R for flange-mounting motors	<b>L08</b>									
Shaft extension with standard dimensions, without featherkey way	<b>L04</b>									
Concentricity of shaft extension in accordance with DIN 42955 Tolerance R	<b>L07</b>									
Standard shaft made of non-rusting steel	<b>L06</b>									
Non-standard cylindrical shaft extension <sup>12)</sup>	<b>Y55 •</b> and identification code									
<b>Heating and ventilation</b>										
Anti-condensation heaters for 230 V	<b>Q02</b>									
Anti-condensation heaters for 115 V	<b>Q03</b>									

For legend and footnotes, see Page 1/63.

# IEC Squirrel-Cage Motors

## New Generation 1LE1/1PC1

### Special versions

Special versions	Additional identification code <b>-Z</b> with order code and plain text if required	Motor type frame size								
		56	63	71	80	90	100	112	132	160
<b>Forced-air cooled motors without external fan and fan cover with improved efficiency</b>										
<b>Forced-air cooled motors without external fan and fan cover with high efficiency</b>										
<b>Self-cooled motors without external fan and fan cover with improved efficiency</b>										
<b>Self-cooled motors without external fan and fan cover with high efficiency</b>										
<b>1LE1/1PC1 (Aluminum)</b>										
<b>Rating plate and extra rating plates</b>										
Second rating plate, loose	<b>M10</b>						✓	✓	✓	✓
Nirosta rating plate	<b>M11</b>						✓	✓	✓	✓
Extra rating plate or rating plate with deviating rating plate data	<b>Y80 •</b> and identification code						✓	✓	✓	✓
Extra rating plate with identification codes	<b>Y82 •</b> and identification code						✓	✓	✓	✓
Additional information on rating plate and on package label (max. of 20 characters)	<b>Y84 •</b> and identification code						✓	✓	✓	✓
<b>Packaging, safety notes, documentation and test certificates</b>										
Without safety and commissioning note. Customer's declaration of renouncement required.	<b>B00</b>						○	○	○	○
With one safety and start-up guide per box pallet	<b>B01</b>						○	○	○	○
Acceptance test certificate 3.1 in accordance with EN 10204	<b>B02</b>						✓	✓	✓	✓
Printed operating instructions English/German enclosed	<b>B04</b>						✓	✓	✓	✓
Type test with heat run for horizontal motors, with acceptance	<b>B83</b>						✓	✓	✓	✓
Wire-lattice pallet	<b>B99</b>						○	○	○	○
Connected in star for dispatch	<b>M01</b>						✓	✓	✓	✓
Connected in delta for dispatch	<b>M02</b>						✓	✓	✓	✓

- Standard version
- Without additional charge
- This order code only determines the price of the version – Additional plain text is required.
- R. Available on request
- ✓ With additional charge

- 1) Not possible in combination with order code **R15** "One cable gland, metal".
- 2) In combination with motor protection (position 15 of the Order No.) or with option anti-condensation heater request required.
- 3) Not possible in combination with voltage code **22** or **34**.
- 4) Not possible in combination with the following order codes: **N01, N02, N03, N05, N06, N07, N08, N11**. Use according to temperature class 155 (F) possible only.
- 5) Cannot be used for motors in UL version (order code **D31**). The grease lifetime specified in catalog part 0 "Introduction" refers to CT 40 °C. When the coolant temperature rises by 10 K, the grease lifetime or relubrication interval is halved.
- 6) Not possible for type of construction IM V3.
- 7) Supplied with the condensation drainage holes sealed at the drive end (DE) and non-drive end (NDE) (IP55, IP56, IP65). If condensation drainage holes are required for motors with IM B6, IM B7 or IM B8 type of construction (feet located on side or top), it is necessary to order the motors in their respective type of construction and order code **H03**, so that the condensation drainage holes can be mounted in the correct positional arrangement.
- 8) 1LE1 motors in EFF1 version without additional charge (standard version).
- 9) Possible up to 600 V max. The rated voltage is indicated on the rating plate without voltage range.
- 10) The rated voltage is indicated on the rating plate without voltage range.
- 11) "Small power motors" with a rated output of up to 3 kW which are exported to Japan must bear the PSE marking.
- 12) When motors are ordered that have a longer or shorter shaft extension than normal, the required position and length of the featherkey way must be specified in a sketch. It must be ensured that only featherkeys in accordance with DIN 6885, Form A are permitted to be used. The featherkey way is positioned centrally on the shaft extension. The length is defined by the manufacturer normatively. Not valid for: Conical shafts, non-standard threaded journals, non-standard shaft tolerances, friction welded journals, extremely "thin" shafts, special geometry dimensions (e.g. square journals), hollow shafts. Valid for non-standard shaft extensions DE or NDE. The featherkeys are supplied in every case. For order code **Y55**:
  - Dimensions D and DA ≤ internal diameter of roller bearing (see dimension tables under "Dimensions")
  - Dimensions E and EA ≤ 2 x length E (normal) of the shaft extension
 For an explanation of the order codes, see catalog part 0 "Introduction".

# IEC Squirrel-Cage Motors

## New Generation 1LE1/1PC1

### Accessories

#### Overview

##### Couplings

The motor from Siemens is connected to the machine or gear unit through a coupling. Flender is an important coupling manufacturer with a wide range of products. For standard applications, Siemens recommends that elastic couplings of Flender types N-Eupex and Rupex or torsionally rigid couplings of types Arpex and Zapex are used. For special applications, Fludex and Elpex couplings are recommended.

Source of supply:  
Siemens contact partner – ordering from Catalog Siemens MD 10.1 “FLENDER Standard Couplings”

or

A. Friedr. Flender AG  
Kupplungswerk Mussum  
Industriepark Bocholt  
Schlavenhorst 100  
46395 Bocholt, Germany  
Tel. +49 (0) 2871-92 2185  
Fax +49 (0) 2871-92 2579

<http://www.flender.com>  
e-mail: [couplings@flender.com](mailto:couplings@flender.com)

##### Mounting of encoder

In the case of mounting by the customer.

Baumer Hübner GmbH  
Planufer 92b  
10967 Berlin, Germany  
Tel. +49 (0) 30-690 03-0  
Fax +49 (0) 30-690 03-104

<http://www.baumerhuebner.com>  
e-mail: [info@baumerhuebner.com](mailto:info@baumerhuebner.com)

Leine & Linde (Deutschland) GmbH  
Bahnhofstraße 36  
73430 Aalen, Germany  
Tel. +49 (0) 7361-78 093-0  
Fax +49 (0) 7361-78 093-11

<http://www.leinelinde.com>  
e-mail: [info@leinelinde.se](mailto:info@leinelinde.se)

#### More information

##### Spare motors and repair parts

- Supply commitment for spare motors and repair parts following delivery of the motor
  - For up to 5 years, in the event of total motor failure, Siemens will supply a comparable motor with regard to the mounting dimensions and functions (the type series may vary).
  - Repair parts will be supplied for up to 5 years.
  - For up to 10 years, Siemens will provide information and will, if necessary, supply documentation for repair parts.
- When repair parts are ordered, the following details must be provided:
  - Designation and part number
  - Order No. and factory number of the motor
- For bearing types, see the „Orientation”, “Technical data”, Page 0/124.
- For standard components, a supply commitment does not apply.
- Support – Hotline  
In Germany  
Tel.: 01 80 – 5 05 04 48

You will find telephone numbers for other countries on our Internet site:

<http://www.siemens.com/automation/service&support>

# IEC Squirrel-Cage Motors

## New Generation 1LE1/1PC1

### Dimensions

#### Overview

#### Overall dimensions

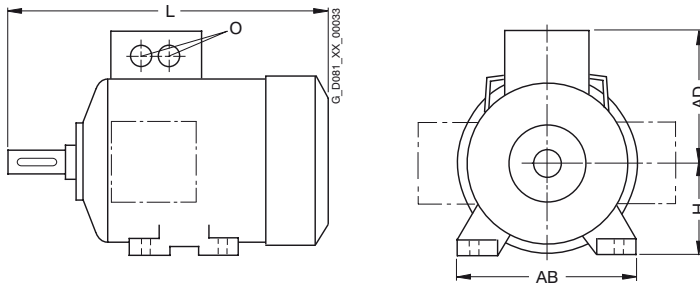

Frame size	Type	Number of poles	Dimensions				
			L	AD	H	AB	O
100 L	General Line motors with shorter delivery time		395.5 <sup>1)</sup>	166	100	196	2 x M32 x 1.5
	Self-ventilated energy-saving motors with improved/high efficiency		395.5 <sup>1)</sup>	166	100	196	2 x M32 x 1.5
	Self-ventilated motors with increased output and improved/high efficiency		430.5 <sup>1)</sup>	166	100	196	2 x M32 x 1.5
	Forced-air-cooled motors without external fan and fan cover with improved/high efficiency		321.5	166	100	196	2 x M32 x 1.5
	Self-cooled motors without external fan and fan cover with improved/high efficiency		321.5	166	100	196	2 x M32 x 1.5
112 M	General Line motors with shorter delivery time		389 <sup>1)</sup>	177	112	226	2 x M32 x 1.5
	Self-ventilated energy-saving motors with improved/high efficiency		389 <sup>1)</sup>	177	112	226	2 x M32 x 1.5
	Self-ventilated motors with increased output and improved/high efficiency		414 <sup>1)</sup>	177	112	226	2 x M32 x 1.5
	Forced-air-cooled motors without external fan and fan cover with improved/high efficiency		311	177	112	226	2 x M32 x 1.5
	Self-cooled motors without external fan and fan cover with improved/high efficiency		311	177	112	226	2 x M32 x 1.5
132 S/ 132 M	General Line motors with shorter delivery time		465 <sup>1)</sup>	202	132	256	2 x M32 x 1.5
	Self-ventilated energy-saving motors with improved/high efficiency		465 <sup>1)</sup>	202	132	256	2 x M32 x 1.5
	Self-ventilated motors with increased output and improved/high efficiency		515 <sup>1)</sup>	202	132	256	2 x M32 x 1.5
	Forced-air-cooled motors without external fan and fan cover with improved/high efficiency		380.5	202	132	256	2 x M32 x 1.5
	Self-cooled motors without external fan and fan cover with improved/high efficiency		380.5	202	132	256	2 x M32 x 1.5
160 M/ 160 L	General Line motors with shorter delivery time		604 <sup>1)</sup>	236.5	160	300	2 x M40 x 1.5
	Self-ventilated energy-saving motors with improved/high efficiency		604 <sup>1)</sup>	236.5	160	300	2 x M40 x 1.5
	Self-ventilated motors with increased output and improved/high efficiency		664 <sup>1)</sup>	236.5	160	300	2 x M40 x 1.5
	Forced-air-cooled motors without external fan and fan cover with improved/high efficiency		510	236.5	160	300	2 x M40 x 1.5
	Self-cooled motors without external fan and fan cover with improved/high efficiency		510	236.5	160	300	2 x M40 x 1.5

<sup>1)</sup> The length is specified as far as the tip of the fan cover.

# IEC Squirrel-Cage Motors

## New Generation 1LE1/1PC1

### Dimensions

#### Overview (continued)

##### Notes on the dimensions

■ Dimension drawings according to DIN EN 50347 and IEC 60072.

##### ■ Fits

The shaft extensions specified in the dimension tables (DIN 748) and centering spigot diameters (DIN EN 50347) are machined with the following fits:

Dimension designation	ISO fit DIN ISO 286-2	
D, DA	up to 30	j6
	over 30 to 50	k6
	over 50	m6
N	up to 250	j6
	over 250	h6
F, FA		h9
K		H17
S	Flange (FF)	H17

The drilled holes of couplings and belt pulleys should have an ISO fit of at least H7.

##### ■ Dimension tolerances

For the following dimensions, the admissible deviations are given below:

Dimension designation	Dimensions	Admissible deviation
H	up to 250	-0.5
	over 250	-1.0
E, EA		-0.5

Keyways and feather keyways (dimensions GA, GC, F and FA) are made in compliance with DIN 6885 Part 1.

■ All dimensions are specified in mm.



#### More information

##### SD configurator

##### SD configurator (on DVD of the interactive catalog CA01 "Products for Automation and Drives")

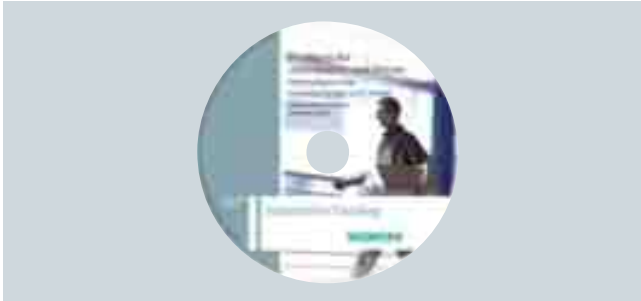

The interactive Catalog CA 01 contains over 100 000 products with approximately 5 million potential drive system product variants.

The **SD configurator** has been developed to facilitate selection of the correct motor and/or converter from the wide spectrum of A&D SD products. It is integrated as a "selection aid" in this catalog.

The **SD configurator** makes it easier to find the right drive solution. It supplies the correct order number as well as the corresponding documentation.

It can display operating instructions, factory test certificate, terminal box documentation, etc. and generates data sheets, dimension drawings and a start-up calculation for the relevant products.

##### Dimension sheet generator

(part of the SD configurator)

A dimension drawing can be created in the SD configurator for every configurable motor. A dimension drawing can be requested for every other motor.

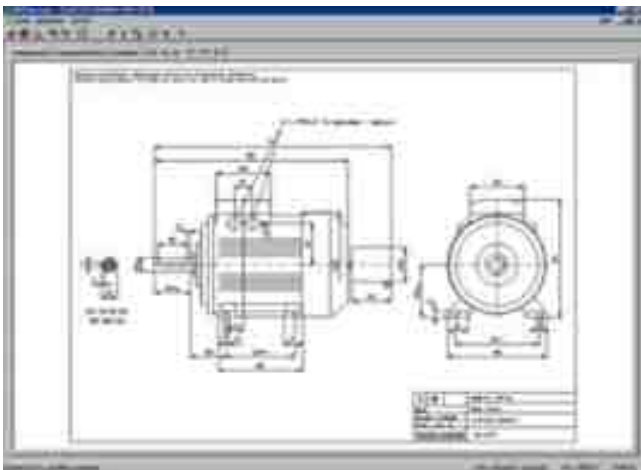

It is also easy to assign a suitable converter to the selected motor.

The extensive help function not only explains the program functions, it also contains extensive technical background material.

##### SD configurator product range:

Low-voltage motors (energy-saving motors) with corresponding documentation and dimension drawings, low-voltage converters of the MICROMASTER 4 product series, SINAMICS G110 and SINAMICS G120 inverter chassis units as well as SINAMICS G120D distributed frequency inverters, and SIMATIC ET 200S FC and SIMATIC ET 200pro FC frequency converters for distributed I/O.

The interactive CA 01 catalog can be ordered from your local Siemens sales representative or on the Internet at <http://www.siemens.com/automation/CA01>

Links to tips, tricks and downloads for functional or content updates can be found at this address.

Order No. for CA 01, English International:  
DVD: **E86060-D4001-A510-C7-7600**

*Note: The SD configurator offline tool within CA 01 can be updated for the new 1LE1 motor series online over the Internet.*

When a complete Order No. is entered with or without order codes, a dimension drawing can be called up under the "Documentation" tab.

These dimension drawings can be presented in different views and sections and printed.

The corresponding dimension sheets can be exported, saved and processed further in DXF format (interchange/import format for CAD systems) or as bitmap graphics.

The SD configurator has been integrated into the CA 01 electronic catalog as a selection aid (for further information, see above).

The interactive CA 01 catalog can be ordered from your local Siemens sales representative or on the Internet at <http://www.siemens.com/automation/CA01>.

At this address, you will also find links to Tips & Tricks and to downloads for function or content updates.

Order No. for CA 01, English International  
DVD: **E86060-D4001-A510-C7-7600**

*Note:*

*The SD configurator offline tool within CA01 can be updated for the new 1LE1 motor series online over the Internet.*

# IEC Squirrel-Cage Motors

## New Generation 1LE1/1PC1

### Dimensions

#### Dimensional drawings

Aluminum series 1LE1, frame sizes 100 to 160 – General Line motors with shorter delivery time

Type of construction IM B3

1

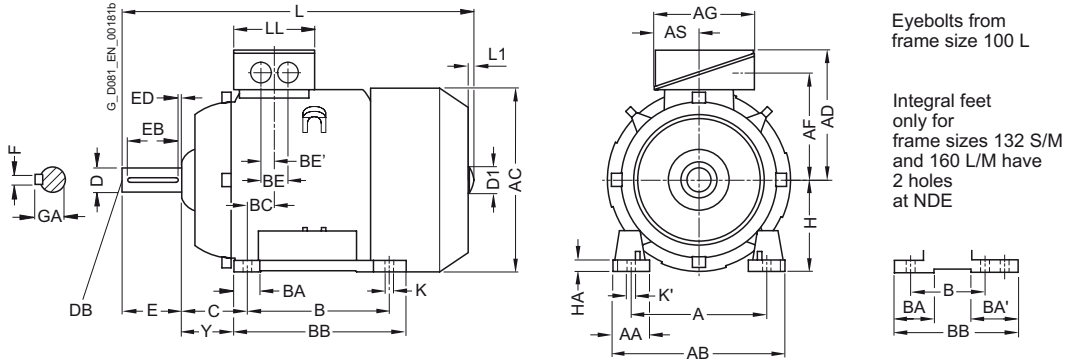

Types of construction IM B5 and IM V1

For flange dimensions, see Page 1/76 (Z = the number of retaining holes)

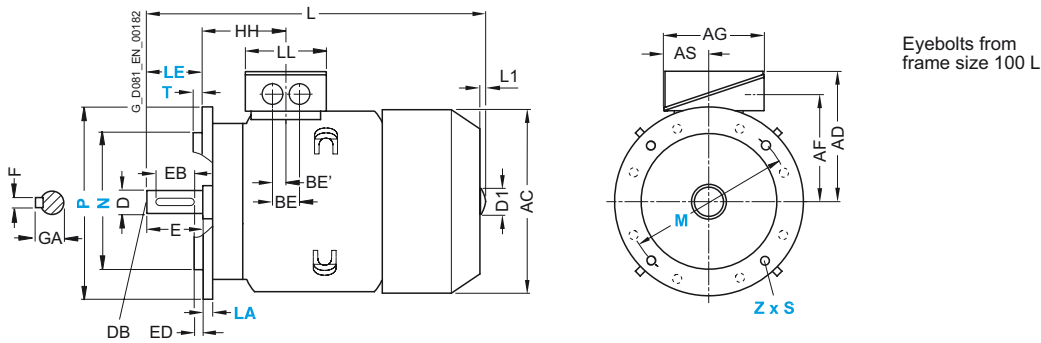

For motor	Frame size	Number of poles	Dimension designation acc. to IEC																		
			A	AA	AB	AC	AD	AF	AG	AS	B*	BA	BA'	BB	BC	BE	BE'	C	H	HA	Y <sup>1)</sup>
	100 L	2, 4, 6, 8	160	42	196	198	166	125.5	135	63.5	140	37.5	-	176	33.5	50	25	63	100	12	45
	112 M	2, 4, 6, 8	190	46	226	222	177	136.5	135	63.5	140	35.4	-	176	26	50	25	70	112	12	52
	132 S	2, 4, 6, 8	216	53	256	262	202	159.5	155	70.5	140	38	76	218	26.5	48	24	89	132	15	69
	132 M	2, 4, 6, 8	216	53	256	262	202	159.5	155	70.5	178	38	76	218	26.5	48	24	89	132	15	69
	160 M	2, 4, 6, 8	254	60	300	314	236.5	190	175	77.5	210	44	89	300	47	57	28.5	108	160	18	85
	160 L	2, 4, 6, 8	254	60	300	314	236.5	190	175	77.5	254	44	89	300	47	57	28.5	108	160	18	85

\* This dimension is assigned in DIN EN 50347 to the frame size listed.

1) Additional information: not a standard dimension acc. to DIN 50347.

#### Dimensional drawings (continued)

Aluminum series 1LE1, frame sizes 100 to 160 – General Line motors with shorter delivery time

#### Type of construction IM B35

For flange dimensions, see Page 1/76 (Z = the number of retaining holes)

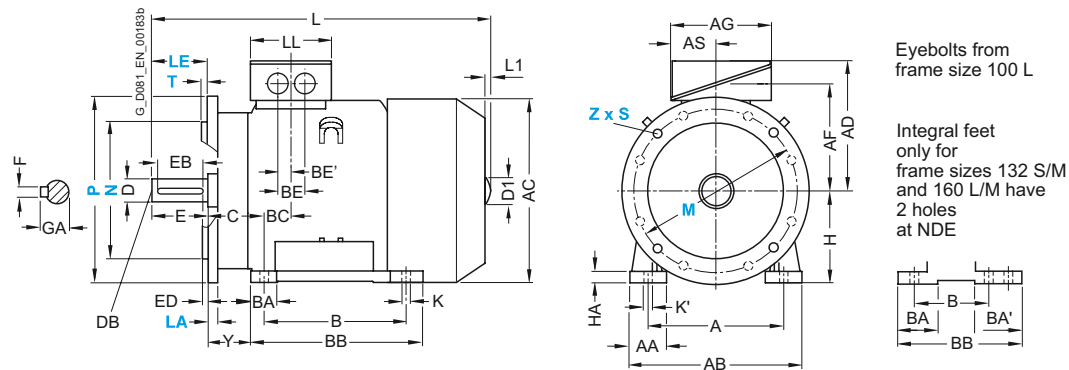

#### Type of construction IM B14

For flange dimensions, see Page 1/76 (Z = the number of retaining holes)

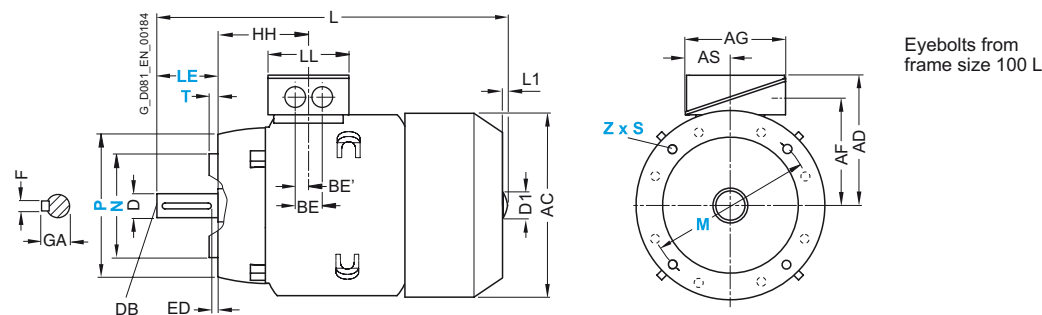

For motor		Dimension designation acc. to IEC					DE shaft extension								
Frame size	Number of poles	HH	K	K'	L <sup>1)</sup>	L1	D1	LL	D	DB	E	EB	ED	F	GA
100 L	2, 4, 6, 8	96.5	12	16	395.5	7	32	112	28	M10	60	50	5	8	31
112 M	2, 4, 6, 8	96	12	16	389	7	32	112	28	M10	60	50	5	8	31
132 S	2, 4, 6, 8	115.5	12	16	465	8.5	39	130	38	M12	80	70	5	10	41
132 M	2, 4, 6, 8	115.5	12	16	465	8.5	39	130	38	M12	80	70	5	10	41
160 M	2, 4, 6, 8	155	15	19	604	10	45	145	42	M16	110	90	10	12	45
160 L	2, 4, 6, 8	155	15	19	604	10	45	145	42	M16	110	90	10	12	45

<sup>1)</sup> The length is specified as far as the tip of the fan cover.

# IEC Squirrel-Cage Motors

## New Generation 1LE1/1PC1

### Dimensions

#### Dimensional drawings (continued)

Aluminum series 1LE1, frame sizes 100 to 160 – self-ventilated motors with improved/high efficiency

#### Type of construction IM B3

1

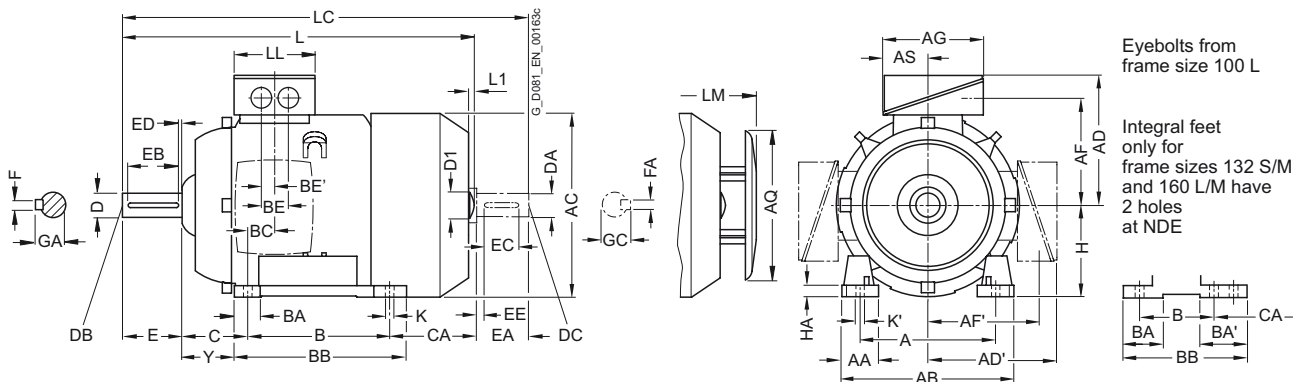

#### Types of construction IM B5 and IM V1

For flange dimensions, see Page 1/76 (Z = the number of retaining holes)

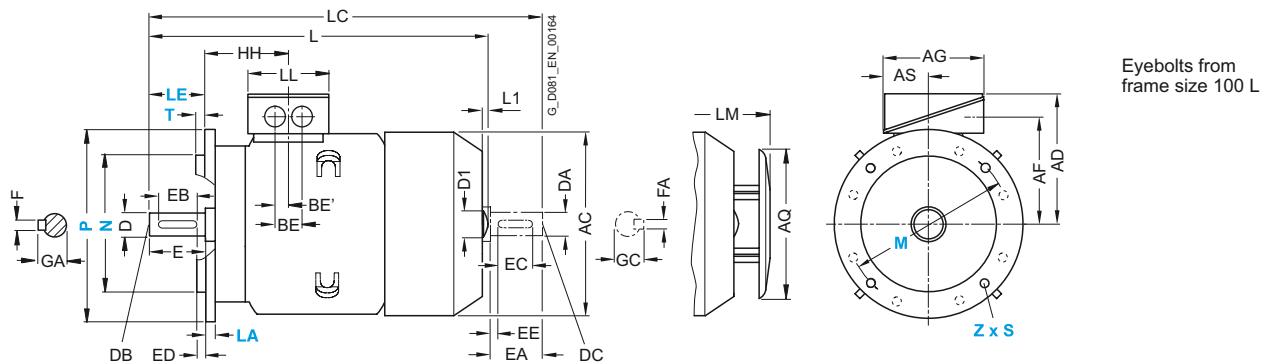

For motor	Frame size	Number of poles	Dimension designation acc. to IEC																						
			A	AA	AB	AC	AD	AD'	AF	AF'	AG	AQ	AS	B*	BA	BA'	BB	BC	BE	BE'	C	CA*	H	HA	Y <sup>1)</sup>
100 L	2, 4, 6, 8		160	42	196	198	166	166	125.5	125.5	135	195	63.5	140	37.5	-	176	33.5	50	25	63	141	100	12	45
112 M	2, 4, 6, 8		190	46	226	222	177	177	136.5	136.5	135	195	63.5	140	35.4	-	176	26	50	25	70	129.7	112	12	52
132 S	2, 4, 6, 8		216	53	256	262	202	202	159.5	159.5	155	260	70.5	140	38	76 <sup>2)</sup>	218 <sup>3)</sup>	26.5	48	24	89	128.5 <sup>4)</sup>	132	15	69
132 M	2, 4, 6, 8		216	53	256	262	202	202	159.5	159.5	155	260	70.5	178	38	76	218	26.5	48	24	89	128.5 <sup>4)</sup>	132	15	69
160 M	2, 4, 6, 8		254	60	300	314	236.5	236.5	190	190	175	260	77.5	210	44	89 <sup>5)</sup>	300 <sup>6)</sup>	47	57	28.5	108	148 <sup>7)</sup>	160	18	85
160 L	2, 4, 6, 8		254	60	300	314	236.5	236.5	190	190	175	260	77.5	254	44	89	300	47	57	28.5	108	148 <sup>7)</sup>	160	18	85

\* This dimension is assigned in DIN EN 50347 to the frame size listed.  
 1) Additional information: not a standard dimension acc. to DIN 50347.  
 2) With screwed-on feet, dimension BA' is 38 mm.  
 3) With screwed-on feet, dimension BB is 180 mm.

4) With screwed-on feet, dimension CA is 166.5 mm.  
 5) With screwed-on feet, dimension BA' is 44 mm.  
 6) With screwed-on feet, dimension BB is 256 mm.  
 7) With screwed-on feet, dimension CA is 192 mm.

### Dimensional drawings (continued)

Aluminum series 1LE1, frame sizes 100 to 160 – self-ventilated motors with improved/high efficiency

#### Type of construction IM B35

For flange dimensions, see Page 1/76 (Z = the number of retaining holes)

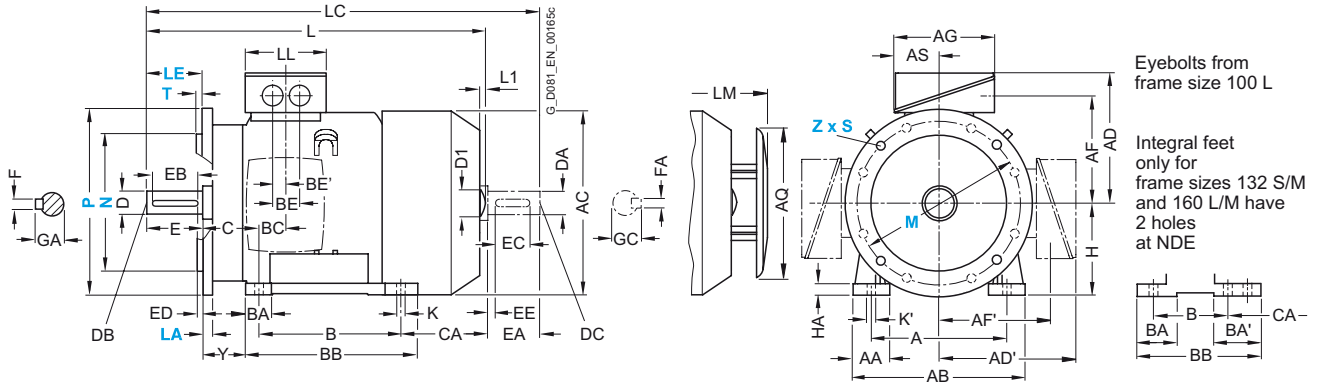

#### Type of construction IM B14

For flange dimensions, see Page 1/76 (Z = the number of retaining holes)

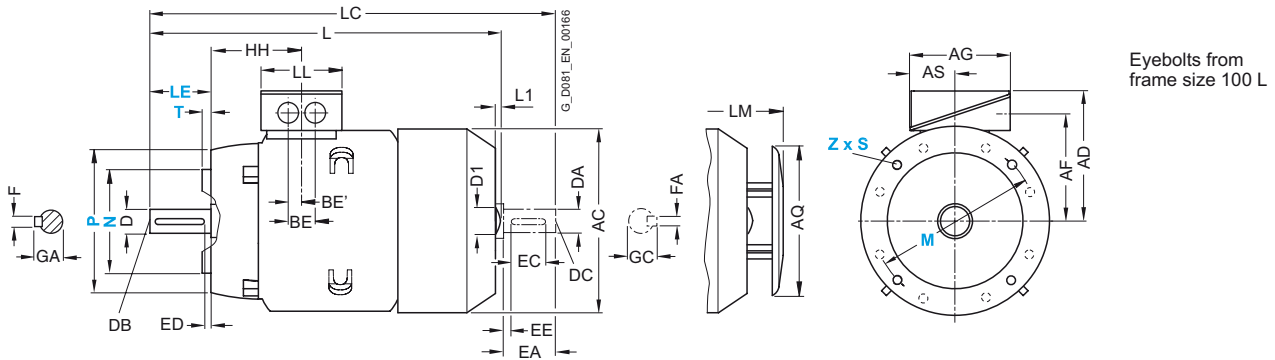

For motor Frame size	Number of poles	Dimension designation acc. to IEC									DE shaft extension					NDE shaft extension								
		HH	K	K'	L <sup>1)</sup>	L1	D1	LC	LL	LM	D	DB	E	EB	ED	F	GA	DA	DC	EA	EC	EE	FA	GC
100 L	2, 4, 6, 8	96.5	12	16	395.5	7	32	454	112	428.5	28	M10	60	50	5	8	31	24	M8	50	40	5	8	27
112 M	2, 4, 6, 8	96	12	16	389	7	32	450	112	422	28	M10	60	50	5	8	31	24	M8	50	40	5	8	27
132 S	2, 4, 6, 8	115.5	12	16	465	8.5	39	535.5	130	500.5	38	M12	80	70	5	10	41	28	M10	60	50	5	8	31
132 M	2, 4, 6, 8	115.5	12	16	465	8.5	39	535.5	130	500.5	38	M12	80	70	5	10	41	28	M10	60	50	5	8	31
160 M	2, 4, 6, 8	155	15	19	604	10	45	730	145	638	42	M16	110	90	10	12	45	42	M16	110	90	10	12	45
160 L	2, 4, 6, 8	155	15	19	604	10	45	730	145	638	42	M16	110	90	10	12	45	42	M16	110	90	10	12	45

<sup>1)</sup> The length is specified as far as the tip of the fan cover.

# IEC Squirrel-Cage Motors

## New Generation 1LE1/1PC1

### Dimensions

#### Dimensional drawings (continued)

Aluminum series 1LE1, frame sizes 100 to 160 – self-ventilated motors with increased output and improved/high efficiency

#### Type of construction IM B3

1

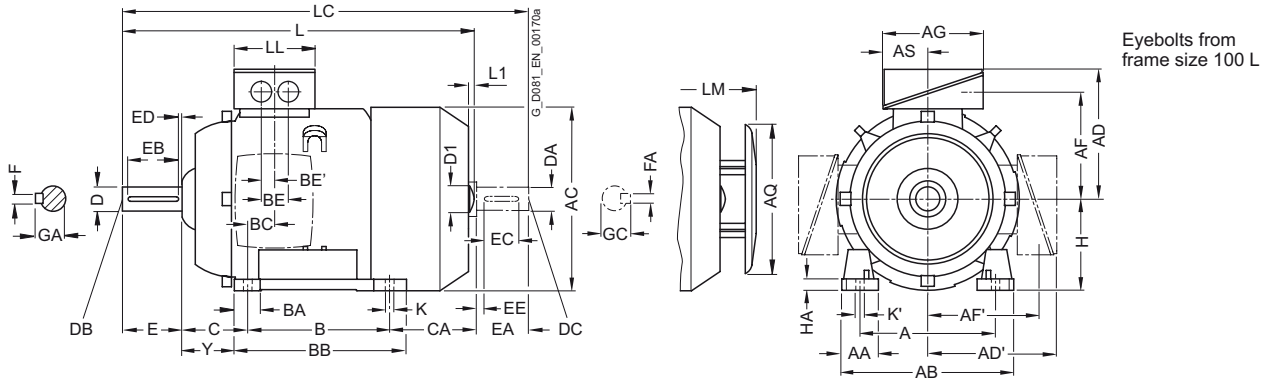

#### Type of construction IM B5 and IM V1

For flange dimensions, see Page 1/76 (Z = the number of retaining holes)

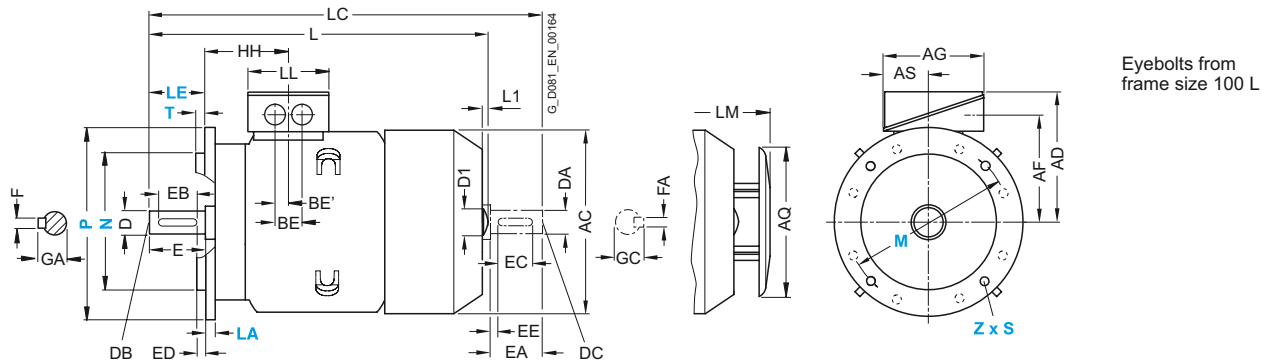

For motor	Frame size	Number of poles	Dimension designation acc. to IEC																						
			A	AA	AB	AC	AD	AD'	AF	AF'	AG	AQ	AS	B*	BA	BA'	BB	BC	BE	BE'	C	CA*	H	HA	Y <sup>1)</sup>
100 L	2, 4, 6, 8		160	42	196	198	166	166	125.5	125.5	135	195	63.5	140	37.5	-	176	33.5	50	25	63	176	100	12	45
112 M	2, 4, 6, 8		190	46	226	222	177	177	136.5	136.5	135	195	63.5	140	35.4	-	176	26	50	25	70	155	112	12	52
132 M	2, 4, 6, 8		216	53	256	262	202	202	159.5	159.5	155	260	70.5	178	38	-	218	26.5	48	24	89	178.5	132	15	69
160 L	2, 4, 6, 8		254	60	300	314	236.5	236.5	190	190	175	260	77.5	254	44	-	300	47	57	28.5	108	208	160	18	85

\* This dimension is assigned in DIN EN 50347 to the frame size listed.

<sup>1)</sup> Additional information: not a standard dimension acc. to DIN 50347.

#### Dimensional drawings (continued)

Aluminum series 1LE1, frame sizes 100 to 160 – self-ventilated motors with increased output and improved/high efficiency

#### Type of construction IM B35

For flange dimensions, see Page 1/76 (Z = the number of retaining holes)

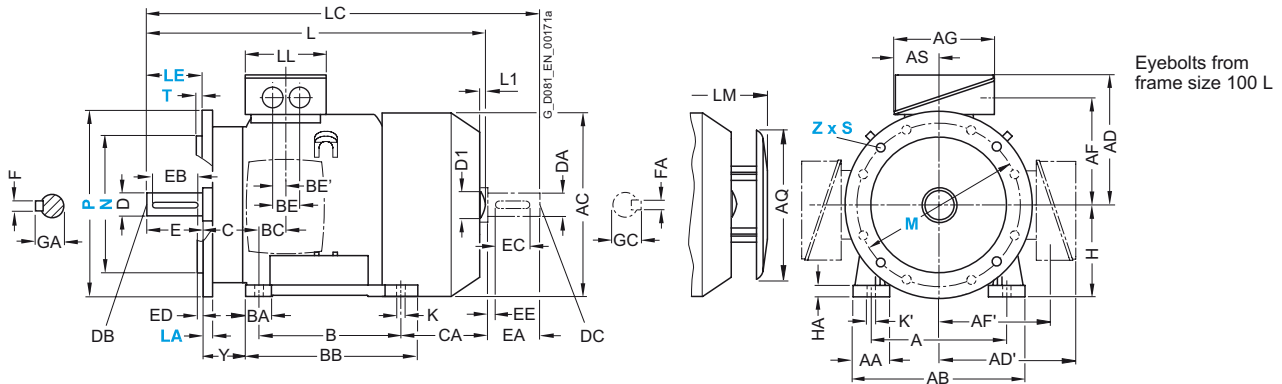

#### Type of construction IM B14

For flange dimensions, see Page 1/76 (Z = the number of retaining holes)

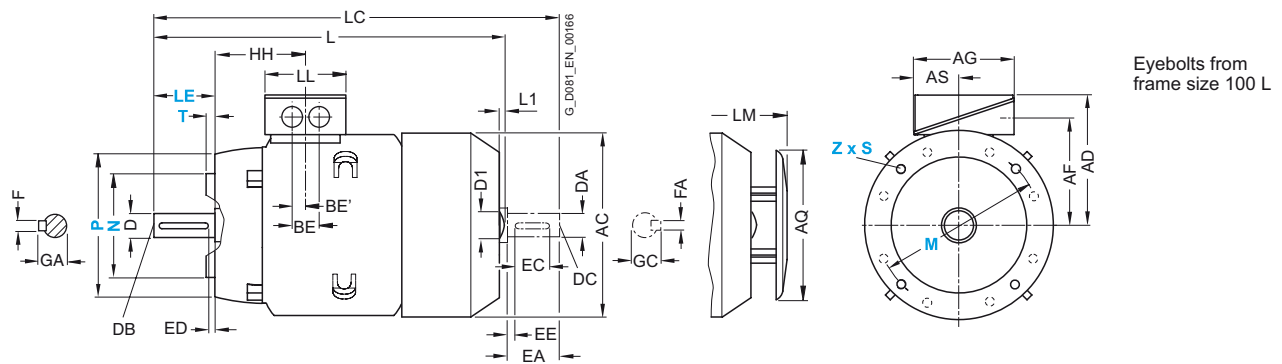

For motor		Dimension designation acc. to IEC									DE shaft extension					NDE shaft extension								
Frame size	Number of poles	HH	K	K'	L <sup>1)</sup>	L1	D1	LC	LL	LM	D	DB	E	EB	ED	F	GA	DA	DC	EA	EC	EE	FA	GC
100 L	2, 4, 6, 8	96.5	12	16	430.5	7	32	489	112	463.5	28	M10	60	50	5	8	31	24	M8	50	40	5	8	27
112 M	2, 4, 6, 8	96	12	16	414	7	32	475	112	447	28	M10	60	50	5	8	31	24	M8	50	40	5	8	27
132 M	2, 4, 6, 8	115.5	12	16	515	8.5	39	585.5	130	550.5	38	M12	80	70	5	10	41	28	M10	60	50	5	8	31
160 L	2, 4, 6, 8	155	15	19	664	10	45	790	145	698	42	M16	110	90	10	12	45	42	M16	110	90	10	12	45

<sup>1)</sup> The length is specified as far as the tip of the fan cover.

# IEC Squirrel-Cage Motors

## New Generation 1LE1/1PC1

### Dimensions

#### Dimensional drawings (continued)

Aluminum series 1LE1, frame sizes 100 to 160 – forced-air cooled motors with improved/high efficiency  
 Aluminum series 1PC1, frame sizes 100 to 160 – self-cooled motors with improved/high efficiency

#### Type of construction IM B3

1

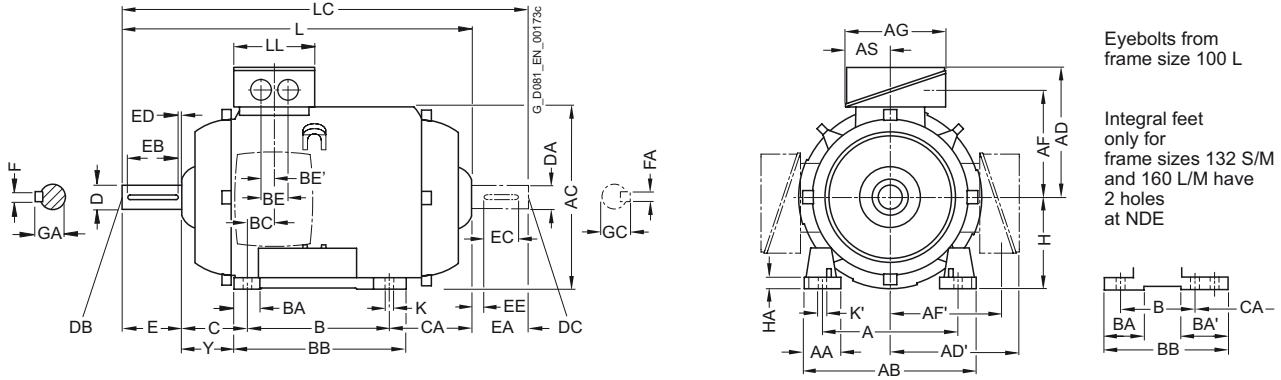

#### Type of construction IM B5 and IM V1

For flange dimensions, see Page 1/76 (Z = the number of retaining holes)

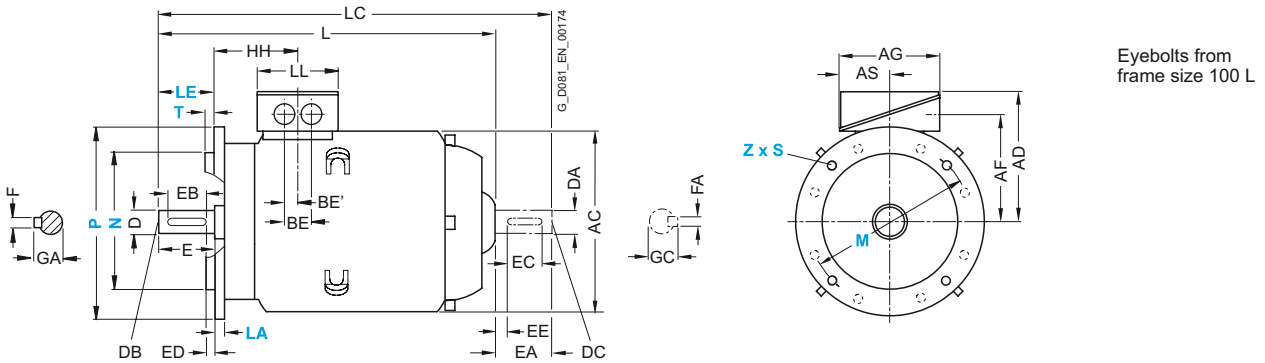

For motor	Frame size	Number of poles	Dimension designation acc. to IEC																					
			A	AA	AB	AC	AD	AD'	AF	AF'	AG	AS	B*	BA	BA'	BB	BC	BE	BE'	C	CA*	H	HA	Y <sup>1)</sup>
100 L	2, 4, 6, 8		160	42	196	197	166	166	125.5	125.5	135	63.5	140	37.5	-	176	33.5	50	25	63	-	100	12	45
112 M	2, 4, 6, 8		190	46	226	221	177	177	136.5	136.5	135	63.5	140	35.4	-	176	26	50	25	70	-	112	12	52
132 S	2, 4, 6, 8		216	53	256	261	202	202	159.5	159.5	155	70.5	140	38	76 <sup>2)</sup>	218 <sup>3)</sup>	26.5	48	24	89	-	132	15	69
132 M	2, 4, 6, 8		216	53	256	261	202	202	159.5	159.5	155	70.5	178	38	76	218	26.5	48	24	89	-	132	15	69
160 M	2, 4, 6, 8		254	60	300	314	236.5	236.5	190	190	175	77.5	210	44	89 <sup>4)</sup>	300 <sup>5)</sup>	47	57	28.5	108	-	160	18	85
160 L	2, 4, 6, 8		254	60	300	314	236.5	236.5	190	190	175	77.5	254	44	89	300	47	57	28.5	108	-	160	18	85

\* This dimension is assigned in DIN EN 50347 to the frame size listed.  
 1) Additional information: not a standard dimension acc. to DIN 50347.  
 2) With screwed-on feet, dimension BA' is 38 mm.

3) With screwed-on feet, dimension BB is 180 mm.  
 4) With screwed-on feet, dimension BA' is 44 mm.  
 5) With screwed-on feet, dimension BB is 256 mm.



# IEC Squirrel-Cage Motors New Generation 1LE1/1PC1

## Dimensions

### Dimensional drawings (continued)

Aluminum series 1LE1, frame sizes 100 to 160 – forced-air cooled motors with improved/high efficiency  
Aluminum series 1PC1, frame sizes 100 to 160 – self-cooled motors with improved/high efficiency

#### Type of construction IM B35

For flange dimensions, see Page 1/76 (Z = the number of retaining holes)

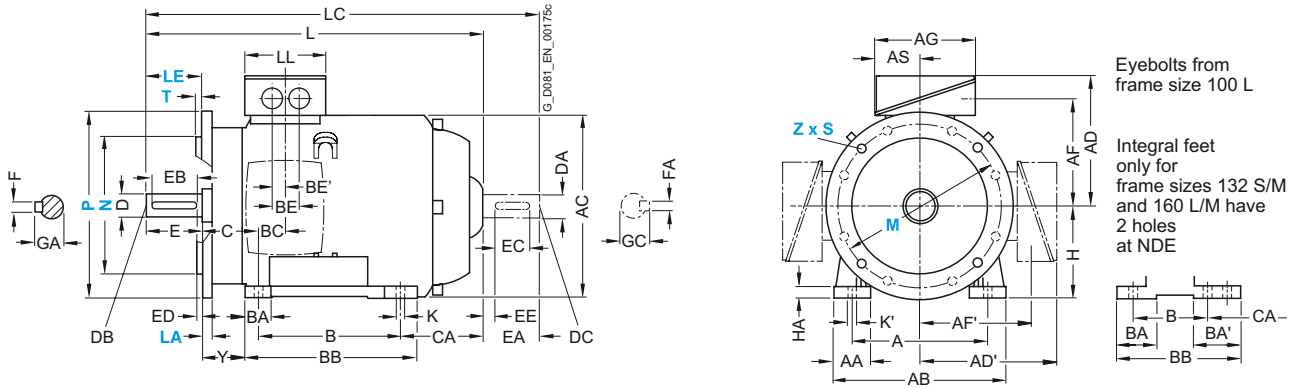

#### Type of construction IM B14

For flange dimensions, see Page 1/76 (Z = the number of retaining holes)

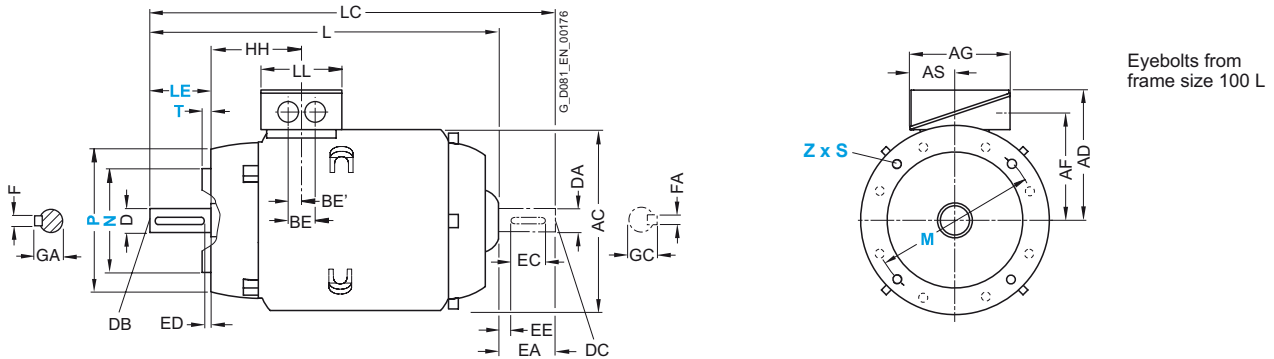

For motor	Frame size	Number of poles	Dimension designation acc. to IEC										DE shaft extension							NDE shaft extension								
			HH	K	K'	L	LC	LL	D	DB	E	EB	ED	F	GA	DA	DC	EA	EC	EE	FA	GC						
100 L	2, 4, 6, 8		96.5	12	16	321.5	-	112	28	M10	60	50	5	8	31	-	-	-	-	-	-	-	-	-	-	-	-	-
112 M	2, 4, 6, 8		96	12	16	311	-	112	28	M10	60	50	5	8	31	-	-	-	-	-	-	-	-	-	-	-	-	-
132 S	2, 4, 6, 8		115.5	12	16	380.5	-	130	38	M12	80	70	5	10	41	-	-	-	-	-	-	-	-	-	-	-	-	-
132 M	2, 4, 6, 8		115.5	12	16	380.5	-	130	38	M12	80	70	5	10	41	-	-	-	-	-	-	-	-	-	-	-	-	-
160 M	2, 4, 6, 8		155	15	19	510	-	145	42	M16	110	90	10	12	45	-	-	-	-	-	-	-	-	-	-	-	-	-
160 L	2, 4, 6, 8		155	15	19	510	-	145	42	M16	110	90	10	12	45	-	-	-	-	-	-	-	-	-	-	-	-	-

# IEC Squirrel-Cage Motors

## New Generation 1LE1/1PC1

### Dimensions

#### Dimensional drawings (continued)

##### Flange dimensions

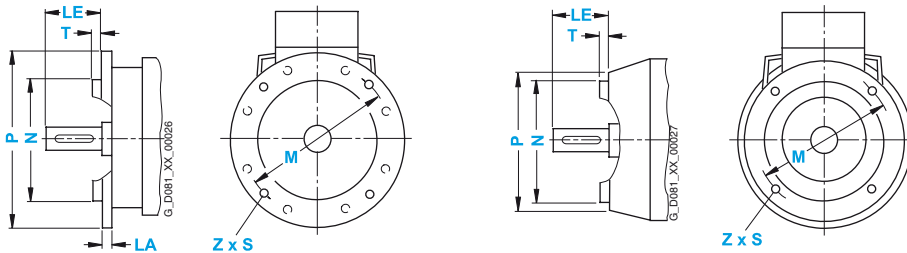

In DIN EN 50347, flanges FF with through holes and flanges FT with tapped holes are assigned to frame sizes. The designation of flange A and C according to DIN 42948 (invalid since 09/2003) are also listed for information purposes. See the table below. (Z = the number of retaining holes)

Frame size	Type of construction	Flange type	Flange with		Dimension designation acc. to IEC								
			Through holes (FF/A)	Tapped holes (FT/C)	LA	LE	M	N	P	S	T	Z	
<b>100 L</b>	IM B5, IM B35, IM V1, IM V3	Flange	<b>FF 215</b>	Acc. to DIN EN 50347	A 250	11	60	215	180	250	14.5	4	4
	IM B14, IM B34, IM V18, IM V19	Standard flange	<b>FT 130</b>	Acc. to DIN 42948	C 160	–	60	130	110	160	M8	3.5	4
	IM B14, IM B34, IM V18, IM V19	Special flange (next larger standard flange)	<b>FT 165</b>		C 200	–	60	165	130	200	M10	3.5	4
<b>112 M</b>	IM B5, IM B35, IM V1, IM V3	Flange	<b>FF 215</b>		A 250	11	60	215	180	250	14.5	4	4
	IM B14, IM B34, IM V18, IM V19	Standard flange	<b>FT 130</b>		C 160	–	60	130	110	160	M8	3.5	4
	IM B14, IM B34, IM V18, IM V19	Special flange (next larger standard flange)	<b>FT 165</b>		C 200	–	60	165	130	200	M10	3.5	4
<b>132 S, 132 M</b>	IM B5, IM B35, IM V1, IM V3	Flange	<b>FF 265</b>		A 300	12	80	265	230	300	14.5	4	4
	IM B14, IM B34, IM V18, IM V19	Standard flange	<b>FT 165</b>		C 200	–	80	165	130	200	M10	3.5	4
	IM B14, IM B34, IM V18, IM V19	Special flange (next larger standard flange)	<b>FT 215</b>		C 250	–	80	215	180	250	M12	4	4
<b>160 M, 160 L</b>	IM B5, IM B35, IM V1, IM V3	Flansch	<b>FF 300</b>		A 350	13	110	300	250	350	18.5	5	4
	IM B14, IM B34, IM V18, IM V19	Normflansch	<b>FT 215</b>		C 250	–	110	215	180	250	M12	4	4

# Standard motors up to frame size 315 L



<b>2/2</b>	<b>Orientation</b>	<b>2/48</b>	<b>Self-ventilated energy-saving motors with high efficiency, Cast-iron series 1LG6</b>
2/2	Overview	2/48	Selection and ordering data
2/4	Benefits		
2/4	Application		
2/5	Integration		
2/7	Technical specifications		
2/8	Selection and ordering data		
2/9	More information		
<b>2/10</b>	<b>Self-ventilated energy-saving motors with improved efficiency, Aluminum series 1LA7 and 1LA5</b>	<b>2/58</b>	<b>Self-cooled motors without external fan, Aluminum series 1LP7 and 1LP5</b>
2/10	Selection and ordering data	2/58	Selection and ordering data
<b>2/22</b>	<b>Self-ventilated energy-saving motors with high efficiency, Aluminum series 1LA9</b>	<b>2/62</b>	<b>Self-cooled motors without external fan, Cast-iron series 1LP4</b>
2/22	Selection and ordering data	2/62	Selection and ordering data
<b>2/34</b>	<b>Self-ventilated motors with increased output, Aluminum series 1LA9</b>	<b>2/66</b>	<b>Special versions</b>
2/34	Selection and ordering data	2/66	Overview
		2/67	Selection and ordering data
		2/67	• Voltages
		2/76	• Types of construction
		2/78	• Options
<b>2/38</b>	<b>Self-ventilated energy-saving motors with improved efficiency, Cast-iron series 1LA6 and 1LG4</b>	<b>2/120</b>	<b>Accessories</b>
2/38	Selection and ordering data	2/120	Overview
		2/121	More information
<b>2/46</b>	<b>Self-ventilated motors with increased output, Cast-iron series 1LG4</b>	<b>2/122</b>	<b>Dimensions</b>
2/46	Selection and ordering data	2/122	Overview
		2/123	More information
		2/124	Dimensional drawings

# IEC Squirrel-Cage Motors

## Standard motors up to frame size 315 L

### Orientation

### Overview



Standard motors from Siemens are characterised by their flexibility, ruggedness and energy efficiency. In general, all motors are suitable for converter-fed operation with mains voltages of up to 460 V + 10 %. The motors are designed to fulfill the requirements of the European and International markets with an output range from 0.06 to 200 kW.

#### Standard motors for use worldwide

##### IEC motors for the European and International market

The standard motors comply both electrically and mechanically with the applicable IEC/EN standards. For exporting to China, CCC certified motors (China Compulsory Certification) can be supplied.

##### IEC motors for the North American market

Motors are also available to the NEMA specification (National Electrical Manufacturers Association), with UL approval (Underwriters Laboratories Inc.) and CSA certification (Canadian Standard Association) for exporting to NAFTA states (USA, Canada and Mexico). The mechanical design of all motors is compliant only to IEC/EN, not to NEMA dimensions.

##### NEMA motors for the North American market

Low-voltage motors are manufactured to the NEMA standard for compliance with the local specifications of the NAFTA markets (USA, Canada and Mexico). This includes motors designed in accordance with the US act, EPACT (specified minimum efficiency levels), as well as motors with NEMA premium efficiency levels. The NEMA motor series provide the highest operating reliability for maximum service life.

Further information regarding NEMA motors is available on the Internet:

<http://www.sea.siemens.com/motors>

#### Classified energy-saving motors for an efficient energy balance

Depending on requirements, energy-saving motors are available for an efficient energy balance – for EU requirements in accordance with CEMEP (European Committee of Manufacturers of Electrical Machines and Power Electronics) and for the North American market in accordance with EPACT (US Energy Policy Act).

##### Efficiency requirements according to CEMEP

CEMEP classifies efficiency levels for 2-pole and 4-pole motors with outputs of 1.1 to 90 kW. Three efficiency classes are defined:

- **EFF1** (High Efficiency motors – referred to below as “Motors with high efficiency”)
- **EFF2** (Improved Efficiency motors – referred to below as “Motors with improved efficiency”)
- **EFF3** (Conventional Efficiency motors)

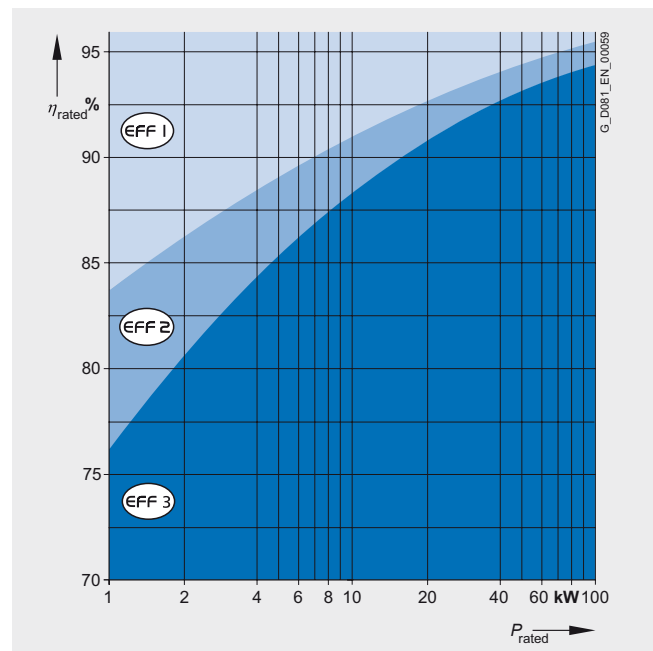

#### At a glance: EU/CEMEP for Europe

- Status  
Voluntary compliance with efficiency classification
- Covers  
2-pole, 4-pole squirrel-cage motors from 1.1 to 90 kW (at 400 V and 50 Hz)
- Required marking  
Efficiency class on the motor rating plate  
 $\eta_N$ ,  $\eta_{3/4}$  load and efficiency class in the documentation

# IEC Squirrel-Cage Motors

## Standard motors up to frame size 315 L

Orientation

### Overview (continued)

#### Efficiency requirements according to EPACT

In 1997, an act was passed in the US to define minimum efficiencies for low-voltage three-phase motors (EPACT).

An act is in force in Canada that is largely identical, although it is based on different verification methods. The efficiency is verified for these motors for the USA using IEEE 112, Test Method B and for Canada using CSA-C390. Apart from a few exceptions, all three-phase low-voltage motors imported into the USA or Canada must comply with the legal efficiency requirements. The law demands minimum efficiency levels for motors with a voltage of 230 and 460 V at 60 Hz, in the output range of 1 to 200 HP (0.75 to 150 kW) with 2, 4 and 6 poles. Explosion-proof motors must also be included.

The EPACT efficiency requirements exclude, for example:

- Motors whose frame size output classification does not correspond with the standard series according to NEMA MG1-12.
- Flange-mounting motors
- Brake motors
- Converter-fed motors
- Motors with design letter C and higher

EPACT lays down that the nominal efficiency at full load and a "CC" number (Compliance Certification) must be included on the rating plate. The "CC" number is issued by the US Department of Energy (DOE). The following information is stamped on the rating plate of EPACT motors which must be marked by law:

- Nominal efficiency
- Design letter
- Code letter
- CONT
- CC No. CC 032A (Siemens) and NEMA MG1-12.

#### At a glance: EPACT/CSA for North America

- Status  
Minimum efficiencies required by law
- Covers  
2-, 4- and 6-pole 60 Hz squirrel-cage motors from 1 to 200 HP (0.75 to 150 kW) for 230 V and/or 460 V 60 Hz
- Required marking  
Efficiency  $\eta_N$  on the motor rating plate

#### Energy-saving motors from Siemens according to CEMEP or EPACT

The product range of standard motors exclusively comprises motors in the EU efficiency classes EFF1 "High Efficiency" or EFF2 "Improved Efficiency". The active parts of the motor have been optimized so that the requirements of the CEMEP efficiency classes EFF1 and EFF2 are fulfilled. The procedure for determining the efficiency is based on the summation of losses in accordance with IEC 60034-2. With these energy-saving motors a significant reduction in energy costs can be achieved as compared to conventional motors according to EFF3.

EPACT motors from Siemens are available CC certified, marked with the number CC032A on the rating plate and optionally also according to UL with the recognition mark. Siemens offers motors with the CSA Energy Efficiency Verification Mark specially for the Canadian market.

#### At a glance: Energy-saving motors from Siemens according to CEMEP EFF1/EFF2, EPACT and CSA

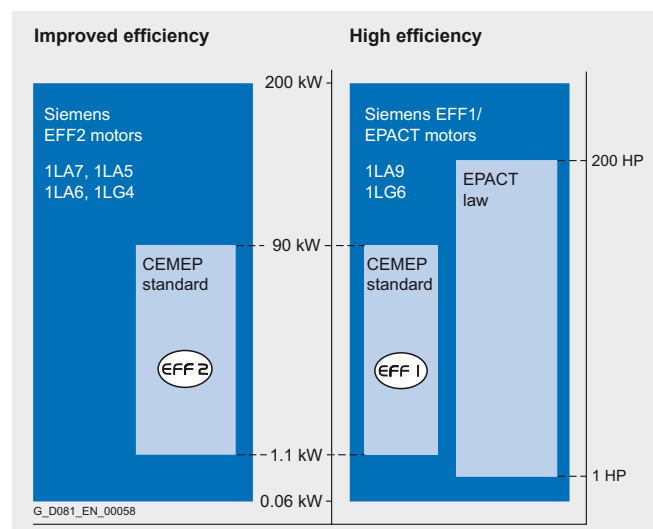
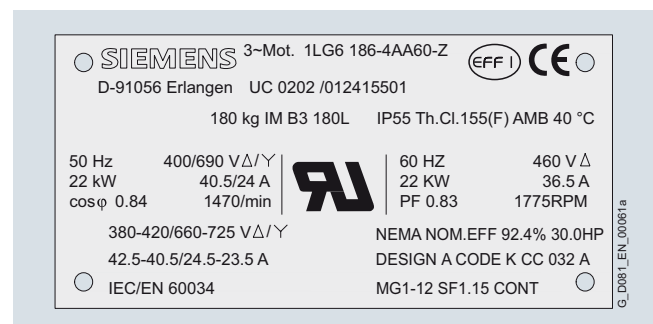
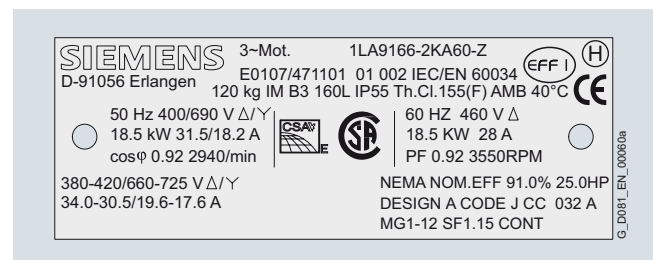

# IEC Squirrel-Cage Motors

## Standard motors up to frame size 315 L

### Orientation

#### Overview (continued)

##### *Standard motors with increased output and compact construction*

Standard motors with increased output and compact construction can be used to advantage in confined spaces. For a slightly longer overall length, the output is at least as high as that of the next largest shaft height. These compact motors are also optimised for efficiency and therefore reduce the operating costs.

##### *Standard motors with reduced output without external fan*

Self-cooled motors with surface cooling without external fan are suitable for the following operating conditions:

- Types of duty with adequate cooling times (e.g. temporary duty for positioning drives)
- Environmental conditions that demand compact installation space (e.g. in motors with a stopping function)
- Conditions under which an external fan has an adverse effect (e.g. simple cleaning in the food industry, textile industry)

##### *Standard motors that can be supplied from stock with an extremely short delivery time*

The most commonly used basic versions of standard motor series 1LA7, 1LA5 and 1LG4 can be supplied from stock – some of these are already marked with “CCC” (China Compulsory Certification) for export to China. Apart from these, a so-called “Sector version” is available for some of the motors available from stock. These include a located bearing at the drive end (DE), PTC thermistor and screwed on feet for the IM B35 type of construction.

The normal delivery time for motors from stock is 1 to 2 days from the time of clarification of the order at the factory until delivery from the factory. To determine the time of arrival at the customer site, the appropriate shipping time must be added.

2

#### Benefits

Standard motors from Siemens offer the user numerous advantages:

- The motors are approved and certified for worldwide use and meet high quality standards (confirmed, for example, by CSA <sup>1)</sup>, UL <sup>2)</sup>, EXAM <sup>3)</sup>, PTB <sup>4)</sup>, CQC <sup>5)</sup>)
- The ruggedness and lack of complexity of the components guarantee an extremely long service life
- Complete product spectrum for energy-saving motors according to EU/CEMEP and EPACT
- Extremely easy selection of energy-saving motors due to the efficiency classification (EFF1/EFF2)
- Energy-saving motors in motor series 1LA9 and 1LG6 meet both the EFF1 and EPACT efficiency levels.
- Reduction in operating costs thanks to a high degree of efficiency with EFF1
- Higher motor service life thanks to lower winding temperature in EFF1 and EPACT motors with rated load and supply
- Reduced environmental impact due to CO<sub>2</sub> reduction
- High overload reserves under continuous duty (SF 1.15 for motor series 1LA9/1LG6)
- Suitable for universal applications worldwide
- Standard motors with increased output and extremely compact construction
- Short delivery times for motors from stock
- The module mounting concept supports rapid modification by the customer
- A fast and comprehensive service is provided by factories and modification partners distributed throughout the world

#### Application

The numerous available options enable standard motors from Siemens to be used in every area of industry and every sector. They are suitable both for special environmental conditions such as those that predominate in the chemical or petrochemical industry as well as for most climatic requirements such as those of offshore applications. Their large range of mains voltages enables them to be used all over the world.

The wide field of implementation includes the following applications:

- Pumps
- Fans
- Compressors
- Conveyor systems such as cranes, belts and lifting gear
- High-bay warehouses
- Packaging machines
- Automation and Drives

<sup>1)</sup> Canadian Standard Association

<sup>2)</sup> Underwriters Laboratories Inc.

<sup>3)</sup> EXAM BBG Prüf und Zertifizier GmbH (previously BVS = Bergbau Versuchsstrecke)

<sup>4)</sup> Physikalisch-Technische Bundesanstalt

<sup>5)</sup> China Quality Certification

### Integration

#### MICROMASTER 411/ COMBIMASTER 411 distributed drive solutions

The MICROMASTER 411/COMBIMASTER 411 series is included in Catalog DA 51.3 which contains the complete product spectrum with ordering data, technical details and explanations.

#### Application

MICROMASTER 411 and COMBIMASTER 411 are the ideal solution for distributed drive applications that require a high degree of protection. The devices are designed for a wide drive range – for simple individual applications for pumps and fans through to multiple drives for conveyor systems in networked control systems. The ECOFAST versions of the MICROMASTER 411/COMBIMASTER 411 frequency converter series contain plug-in cables for the power supply, communications interface and motor connections. They support fast and problem-free replacement in time-critical applications and are completely compatible with the ECOFAST technology systems. They are based on the universal MICROMASTER 420 converter series and are characterised by customer-oriented performance and ease of use.

#### Structure

The modular structure allows MICROMASTER 411/COMBIMASTER 411 products and their accessories to be individually selected, e.g. electromechanical brake control module or PROFIBUS module.

#### Main features:

- Output range: 0.37 to 3.0 kW, 400 V, 3AC
- IP66 degree of protection (MICROMASTER 411), self-cooling
- Electrical isolation between the electronics and the connection terminals
- Parameter sets for fast startup and cost savings
- Modular structure with numerous accessories
- Operation without operator panel possible (using jumpers and/or control potentiometer)
- Integrated control potentiometer accessible from outside.

#### Accessories (overview):

- Basic Operator Panel (BOP) for parameterising the converter
- Plain text Advanced Operator Panel (AOP) for MICROMASTER 411 and COMBIMASTER 411 with multiple-language display
- PROFIBUS module
- AS-Interface module
- DeviceNet module
- REM module (dynamic brake and control module for electro-mechanical brake)
- EM module (electromechanical brake control module)
- PC connection kit
- Mounting kits for installing the operator panels
- PC startup programs

### ECOFAST system

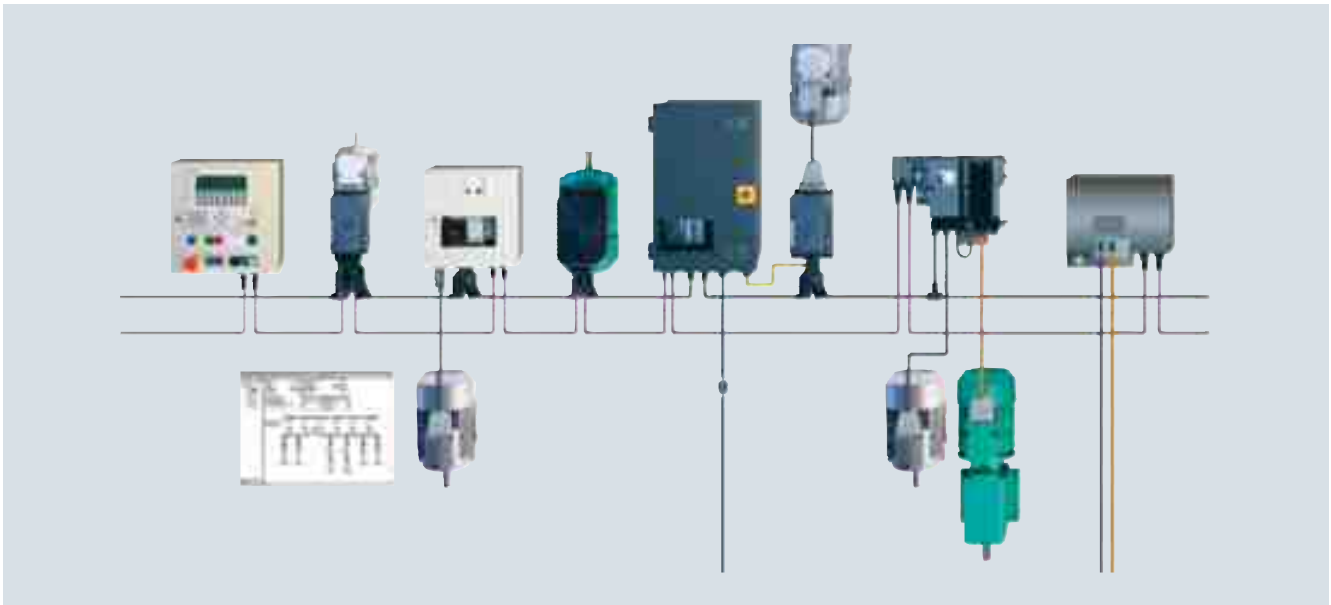

ECOFAST is a system which permits extensive decentralisation and a modular structure for installation elements on the component level.

# IEC Squirrel-Cage Motors

## Standard motors up to frame size 315 L

### Orientation

#### Integration (continued)

##### Advantages

The main advantages of the ECOFAST motor connector over a terminal strip are as follows:

- Fast assembly of I/O devices (e.g. motor starters) from the ECOFAST system
- Reduction of assembly and repair times at the end user
- No wiring errors due to connector technology
- Replacement of motor without intervention in the electronics

##### Main features of the ECOFAST motor connector (with separate MICROMASTER 411 frequency converter)

The motor connector is mounted in the factory and replaces the connection box with terminal board. The connector is mounted towards the non-drive end (NDE). It comprises an angled motor connection casing that can be rotated by 4 x 90°. A 10-pole (+ earth) male insert is used in the housing. In the plug-in connector, the winding connections are connected and optionally the power supply for the brake and the signal leads for the temperature sensors.

The ECOFAST motor connector is compatible with the products of the ECOFAST field device system. Further information can be found in Catalog IK PI.

The mounting dimensions of this casing match those of standard industrial connectors, so it is possible to use a complete series of different standard inserts (such as Han E, ES, ESS from Harting). The motor circuit (star or delta connection) is selected in the mating connector for motor connection. The relevant jumpers are inserted by the customer in the mating connector. As a casing for the mating connector, all standard sleeve casings with lengthwise locking, frame size 10B (e.g. from Harting) can be used.

Only one sensor (temperature sensor or PTC thermistor) can be connected.

Maximum admissible mains voltage on motor connector: ≤500 V

##### Availability of the ECOFAST motor connector

The ECOFAST motor connector can be supplied for the following motor versions with the exception of the explosion-proof motors:

- Frame sizes 56 M to 132 M
- Output range 0.06 to 5.5 kW (7.5 kW on request)
- Direct on-line starting: Voltage code 1 for 230 VΔ/400 VY, 50 Hz
- Star-delta starting: Voltage code **9** with order code **L1U** 400 VΔ, 50 Hz

##### More information

Further information is available in the Catalogs IK PI and DA 51.3 "MICROMASTER 411/COMBIMASTER 411 distributed drive solutions" as well as on the Internet at:

<http://www.siemens.com/ecofast>



### Technical specifications

The following table lists the most important technical specifications. For further information and details, see catalog part 0 "Introduction".

#### Technical specifications at a glance

Type of motor	IEC squirrel-cage motor
Connection types	Star connection/delta connection You can establish the connection type used from the Order No. supplements in the selection and ordering data for the required motor.
Number of poles	2, 4, 6, 8, pole-changing for constant load torque (pole-changing for fans, see catalog part 7 "Fan motors")
Rated speed (synchronous speed)	750 ... 3000 rpm
Rated output	0.06 ... 200 kW
Rated torque	0.25 ... 1700 Nm
Insulation of the stator winding to EN 60034-1 (IEC 60034-1)	Temperature class 155 (F), used acc. to temperature class 130 (B) DURIGNIT IR 2000 insulation system
Degree of protection according to EN 60034-5 (IEC 60034-5)	IP55 as standard
Cooling according to EN 60034-6 (IEC 60034-6)	Self-ventilated (motor series 1LA, 1LG) Frame sizes 63 to 315 (IC 411), Frame size 56 (IC 410) Self-cooled (motor series 1LP) Frame sizes 63 to 315 (IC 410)
Admissible coolant temperature and site altitude	-20 °C ... +40 °C as standard, site altitude 1000 mm above sea level. See "Coolant temperature and site altitude" in catalog part 0 "Introduction".
Standard voltages according to EN 60038 (IEC 60038)	50 Hz: 230 V, 400 V, 500 V, 690 V The voltage used can be found in the selection and ordering data for the required motor.
Type of construction according to EN 60034-7 (IEC 60034-7):	Without flange: IM B3, IM B6, IM B7, IM B8, IM V5 without protective cover, IM V6, IM V5 with protective cover With flange: IM B5, IM V1 without protective cover, IM V1 with protective cover, IM V3, IM B35 With standard flange: IM B14, IM V19, IM V18 without protective cover, IM V18 with protective cover, IM B34 With special flange: IM B14, IM V19, IM V18 without protective cover, IM V18 with protective cover, IM B34
Paint finish Suitability of paint finish for climate group according to IEC 60721, Part 2-1	Standard: Color RAL 7030 stone gray Climate group "worldwide" with special finish Climate group "moderate" with standard finish See "Paint finish" in catalog part 0 "Introduction".
Vibration quantity level according to EN 60034-14 (IEC 60034-14)	Level A (standard – without special vibration requirements) Level B (with special vibration requirements) See "Balance and vibration quantity" in catalog part 0 "Introduction".
Shaft extension according to DIN 748 (IEC 60072)	Balance type: Half-key balancing See "Balance and vibration quantity" in catalog part 0 "Introduction".
Sound pressure level to DIN EN ISO 1680 (tolerance +3dB)	The sound pressure level is listed in the selection and ordering data for the required motor.
Weights	The weight is listed in the selection and ordering data for the required motor.
Mechanical limit speeds	The limit speed for the required motor can be found on Page 5/6.
Packaging weights and dimensions	See "Packing weights and packing dimensions" in catalog part 0 "Introduction".
Rating plates	Fixed to the motor See "Rating plate" in catalog part 0 "Introduction".
Connection and connection boxes	See "Connection, circuit and connection box" in catalog part 0 "Introduction".
Bearing design	See "Bearings" in catalog part 0 "Introduction".
Cantilever forces	See "Admissible cantilever forces" in catalog part 0 "Introduction".
Options	See the selection and ordering data for "Special versions"

#### General note

All the data listed in the catalog is applicable for a 50 Hz line supply. With converter-fed operation, the reduction factors for constant torque and drives for fans, pumps and compressors must be observed. Noise values for motors operating with a converter at frequencies other than 50 Hz are available on request.

#### Mechanical limit speeds

When the motor is operated at its rated frequency, it is important to note that the maximum speeds are limited by the limits for the roller bearings, critical rotor speed and rigidity of the rotating parts.

#### Ventilation/noise generation (converter-fed operation)

The fan noise can increase at speeds that are higher than the rated speed of self-ventilated motors. To increase motor utilization at low speeds it is recommended that forced-ventilated motors are used.

#### Mechanical stress and grease lifetime (converter-fed operation)

High speeds that exceed the rated speed and the resulting increased vibrations alter the mechanical running smoothness and the bearings are subjected to increased mechanical stress. This reduces the grease lifetime and the bearing lifetime. More detailed information on request.

# IEC Squirrel-Cage Motors

## Standard motors up to frame size 315 L

### Orientation

#### Selection and ordering data

*Preliminary selection of the motor according to motor type/series, speed or number of poles, frame size, rated output, rated torque, rated speed and rated current*

#### Self-ventilated energy-saving motors with improved efficiency

Speed	Frame size	Rated output	Rated speed	Rated torque	Rated current at 400 V	Detailed selection and ordering data Page
rpm		kW	rpm	Nm	A	
<b>Aluminum series 1LA7 and 1LA5 (motors with external fan)</b>						
<b>3000, 2-pole</b>	<b>56 M ... 225 M</b>	0.09 ... 45	2830 ... 2960	0.30 ... 145	0.26 ... 78	<b>2/10 ... 2/11</b>
<b>1500, 4-pole</b>	<b>56 M ... 225 M</b>	0.06 ... 45	1350 ... 1470	0.42 ... 292	0.2 ... 80	<b>2/12 ... 2/13</b>
<b>1000, 6-pole</b>	<b>63 M ... 225 M</b>	0.09 ... 30	850 ... 978	1 ... 293	0.44 ... 61	<b>2/14 ... 2/15</b>
<b>750, 8-pole</b>	<b>71 M ... 225 M</b>	0.09 ... 22	630 ... 724	1.4 ... 290	0.36 ... 44.5	<b>2/16 ... 2/17</b>
<b>1500/3000, 4/2-pole</b>	<b>63 M ... 200 L</b>	0.1 ... 26	1330 ... 1465	0.72 ... 169	0.41 ... 48.5	<b>2/18 ... 2/19</b>
<b>750/1500, 8/4-pole</b>	<b>90 S ... 200 L</b>	0.35 ... 17	675 ... 730	5.1 ... 223	1.19 ... 40.5	<b>2/20 ... 2/21</b>
<b>Cast-iron series 1LA6 and 1LG4 (motors with external fan)</b>						
<b>3000, 2-pole</b>	<b>100 L ... 315 L</b>	3 ... 200	2890 ... 2982	9.9 ... 641	6.1 ... 325	<b>2/38 ... 2/39</b>
<b>1500, 4-pole</b>	<b>100 L ... 315 L</b>	2.2 ... 200	1420 ... 1496	15 ... 1285	4.7 ... 340	<b>2/40 ... 2/41</b>
<b>1000, 6-pole</b>	<b>100 L ... 315 L</b>	1.5 ... 160	925 ... 988	15 ... 1547	3.9 ... 285	<b>2/42 ... 2/43</b>
<b>750, 8-pole</b>	<b>100 L ... 315 L</b>	0.75 ... 132	679 ... 738	11 ... 1708	2.15 ... 245	<b>2/44 ... 2/45</b>

#### Self-ventilated energy-saving motors with high efficiency

Speed	Frame size	Rated output	Rated speed	Rated torque	Rated current at 400 V	Detailed selection and ordering data Page
rpm		kW/HP	rpm	Nm	A	
<b>Aluminum series 1LA9 (motors with external fan)</b>						
<b>For use according to CEMEP</b>						
<b>3000, 2-pole</b>	<b>56 M ... 200 L</b>	0.09 ... 37	2830 ... 2950	0.3 ... 120	0.24 ... 64	<b>2/22 ... 2/23</b>
<b>1500, 4-pole</b>	<b>56 M ... 200 L</b>	0.06 ... 30	1380 ... 1465	0.42 ... 196	0.22 ... 53	<b>2/24 ... 2/25</b>
<b>1000, 6-pole</b>	<b>90 S ... 200 L</b>	0.75 ... 22	925 ... 975	7.7 ... 215	2 ... 45	<b>2/26 ... 2/27</b>
<b>For use in the North American market according to EPACT</b>						
<b>3600, 2-pole</b>	<b>56 M ... 200 L</b>	0.12 ... 50	3440 ... 3555	0.25 ... 100	0.23 ... 57	<b>2/28 ... 2/29</b>
<b>1800, 4-pole</b>	<b>56 M ... 200 L</b>	0.08 ... 40	1715 ... 1770	0.33 ... 161	0.18 ... 47	<b>2/30 ... 2/31</b>
<b>1200, 6-pole</b>	<b>90 S ... 200 L</b>	1 ... 30	1140 ... 1175	6.2 ... 182	1.78 ... 40	<b>2/32 ... 2/33</b>
<b>Cast-iron series 1LG6 (motors with external fan)</b>						
<b>For use according to CEMEP</b>						
<b>3000, 2-pole</b>	<b>180 M ... 315 L</b>	22 ... 200	2955 ... 2982	71 ... 641	38.5 ... 320	<b>2/48 ... 2/49</b>
<b>1500, 4-pole</b>	<b>180 M ... 315 L</b>	18.5 ... 200	1470 ... 1490	120 ... 1282	34.5 ... 340	<b>2/48 ... 2/49</b>
<b>1000, 6-pole</b>	<b>180 M ... 315 L</b>	15 ... 160	975 ... 990	147 ... 1543	29.5 ... 280	<b>2/50 ... 2/51</b>
<b>750, 8-pole</b>	<b>180 M ... 315 L</b>	11 ... 132	725 ... 740	145 ... 1704	23.5 ... 240	<b>2/50 ... 2/51</b>
<b>For use in the North American market according to EPACT</b>						
<b>3600, 2-pole</b>	<b>180 M ... 315 L</b>	30 ... 300	3560 ... 3591	60 ... 595	34 ... 320	<b>2/52 ... 2/53</b>
<b>1800, 4-pole</b>	<b>180 M ... 315 L</b>	25 ... 300	1775 ... 1792	100 ... 1193	31 ... 335	<b>2/54 ... 2/55</b>
<b>1200, 6-pole</b>	<b>180 M ... 315 L</b>	20 ... 200	1178 ... 1192	121 ... 1195	25.5 ... 235	<b>2/56 ... 2/57</b>

#### Self-ventilated motors with increased output

Speed	Frame size	Rated output	Rated speed	Rated torque	Rated current at 400 V	Detailed selection and ordering data Page
rpm		kW	rpm	Nm	A	
<b>Aluminum series 1LA9 (motors with external fan)</b>						
<b>3000, 2-pole</b>	<b>56 M ... 200 L</b>	0.2 ... 53	2830 ... 2944	0.67 ... 172	0.51 ... 95	<b>2/34 ... 2/35</b>
<b>1500, 4-pole</b>	<b>56 M ... 200 L</b>	0.14 ... 43	1384 ... 1465	0.97 ... 280	0.44 ... 80	<b>2/36 ... 2/37</b>
<b>Cast-iron series 1LG4 (motors with external fan)</b>						
<b>3000, 2-pole</b>	<b>180 M ... 280 M</b>	30 ... 110	2950 ... 2975	97 ... 353	54 ... 184	<b>2/46 ... 2/47</b>
<b>1500, 4-pole</b>	<b>180 L ... 280 M</b>	30 ... 110	1465 ... 1488	196 ... 706	59 ... 198	<b>2/46 ... 2/47</b>
<b>1000, 6-pole</b>	<b>180 L ... 280 M</b>	18.5 ... 75	970 ... 985	182 ... 727	37.5 ... 136	<b>2/46 ... 2/47</b>
<b>750, 8-pole</b>	<b>180 L ... 280 M</b>	15 ... 55	720 ... 735	199 ... 715	34 ... 106	<b>2/46 ... 2/47</b>

# IEC Squirrel-Cage Motors

## Standard motors up to frame size 315 L

Orientation

### Selection and ordering data (continued)

#### Self-cooled motors without external fan

Speed	Frame size	Rated output	Rated speed	Rated torque	Rated current at 400 V	Detailed selection and ordering data Page
rpm		kW	rpm	Nm	A	
<b>Aluminum series 1LP7 and 1LP5 (motors without external fan)</b>						
<b>3000, 2-pole</b>	<b>63 M ... 200 L</b>	0.12 ... 16.5	The electrical data can be calculated and supplied on receipt of order.			<b>2/58</b>
<b>1500, 4-pole</b>	<b>63 M ... 200 L</b>	0.07 ... 12				<b>2/59</b>
<b>1000, 6-pole</b>	<b>63 M ... 200 L</b>	0.045 ... 8.5				<b>2/60</b>
<b>750, 8-pole</b>	<b>63 M ... 200 L</b>	0.045 ... 7.5				<b>2/61</b>
<b>Cast-iron series 1LP4 (motors with external fan)</b>						
<b>3000, 2-pole</b>	<b>180 M ... 315 L</b>	7.3 ... 67	2945 ... 2984	24 ... 214	0.068 ... 2.09	<b>2/62</b>
<b>1500, 4-pole</b>	<b>180 M ... 315 L</b>	6.2 ... 67	1465 ... 1488	40 ... 430	0.099 ... 3.46	<b>2/63</b>
<b>1000, 6-pole</b>	<b>180 L ... 315 L</b>	5 ... 44	970 ... 990	49 ... 424	0.175 ... 4.02	<b>2/64</b>
<b>750, 8-pole</b>	<b>180 L ... 315 L</b>	3.7 ... 37	725 ... 740	49 ... 477	0.169 ... 3.95	<b>2/65</b>

### More information

For more information, please contact your local Siemens contact – see “Siemens Contacts Worldwide” in the Appendix.

2

# IEC Squirrel-Cage Motors

## Standard motors up to frame size 315 L

Self-ventilated energy-saving motors with improved efficiency – Aluminum series 1LA7/1LA5

### Selection and ordering data

Rated output at		Frame size	Operating values at rated output							Order No.	Price	Weight
50 Hz	60 Hz		Rated speed at 50 Hz	Rated torque at 50 Hz	Efficiency Class according to CEMEP	Efficiency at 50 Hz 4/4-load	Efficiency at 50 Hz 3/4-load	Power factor at 50 Hz 4/4-load	Rated current at 400 V, 50 Hz			
$P_{rated}$ kW	$P_{rated}$ kW	FS	$n_{rated}$ rpm	$T_{rated}$ Nm	EFF2	$\eta_{rated}$ %	$\eta_{rated}$ %	$\cos\phi_{rated}$	$I_{rated}$ A	Phase-out model	$m$ kg	
<b>2-pole, 3000 rpm at 50 Hz, 3600 rpm at 60 Hz, temperature class 155 (F), IP55 degree of protection</b>												
0.09	0.11	56 M	2830	0.3		63	62	0.81	0.26	1LA7 050-2AA□□	3	
0.12	0.14	56 M	2800	0.41		65	64	0.83	0.32	1LA7 053-2AA□□	3	
0.18	0.21	63 M	2820	0.61		64	63	0.79	0.51	1LA7 060-2AA□□	3.5	
0.25	0.29	63 M	2830	0.84		65	65	0.80	0.69	1LA7 063-2AA□□	4.1	
0.37	0.43	71 M	2740	1.3		66	65	0.82	1	1LA7 070-2AA□□	5	
0.55	0.63	71 M	2800	1.9		71	70	0.82	1.36	1LA7 073-2AA□□	6	
0.75	0.86	80 M	2855	2.5		73	72	0.86	1.73	1LA7 080-2AA□□	9	
1.1	1.3	80 M	2845	3.7	EFF2	77	77	0.87	2.4	1LA7 083-2AA□□	11	
1.5	1.75	90 S	2860	5	EFF2	79	80	0.85	3.25	1LA7 090-2AA□□	12.9	
2.2	2.55	90 L	2880	7.3	EFF2	82	82	0.85	4.55	1LA7 096-2AA□□	15.7	
3	3.45	100 L	2890	9.9	EFF2	84	84	0.85	6.1	1LA7 106-2AA□□	22	
4	4.6	112 M	2905	13	EFF2	86	86	0.86	7.8	1LA7 113-2AA□□	29	
5.5	6.3	132 S	2925	18	EFF2	86.5	86.5	0.89	10.4	1LA7 130-2AA□□	39	
7.5	8.6	132 S	2930	24	EFF2	88	88	0.89	13.8	1LA7 131-2AA□□	48	
11	12.6	160 M	2930	36	EFF2	89.5	89.5	0.88	20	1LA7 163-2AA□□	68	
15	17.3	160 M	2930	49	EFF2	90	90.2	0.9	26.5	1LA7 164-2AA□□	77	
18.5	21.3	160 L	2940	60	EFF2	91	91.2	0.91	32	1LA7 166-2AA□□	86	
22	24.5	180 M	2940	71	EFF2	91.7	91.7	0.88	39.5 <sup>1)</sup>	1LA5 183-2AA□□	113	
30	33.5	200 L	2945	97	EFF2	92.3	92.3	0.89	53	1LA5 206-2AA□□	159	
37	41.5	200 L	2945	120	EFF2	92.8	92.8	0.89	65 <sup>1)</sup>	1LA5 207-2AA□□	179	
45	51	225 M	2960	145	EFF2	93.6	93.6	0.89	78 <sup>1)</sup>	1LA5 223-2AA□□	209	

### Order No. supplements

Motor type	Penultimate position: Voltage code						Final position: Type of construction code						
	50 Hz			60 Hz			Without flange	With flange		With standard flange		With special flange	
	230 VΔ/400 VY	400 VΔ/690 VY	500 VY	500 VΔ	460 VY	460 VΔ	IM B3/6/7/8, IM V6, IM V5 without protective cover	IM B5, IM V1 without protective cover <sup>2)</sup>	IM V1 with protective cover <sup>2)3)</sup>	IM B35	IM B14, IM V19, IM V18 without protective cover	IM B34	IM B14, IM V19, IM V18 without protective cover
1	6	3	5	1	6	0	1	4	6	2	7	3	
1LA7 05 . . . . □□	○	○	○	–	○	○	□	✓	–	✓	✓	✓	✓
1LA7 06 . . . . □□	○	○	○	–	○	○	□	✓	✓	✓	✓	✓	✓
1LA7 07 . . . . □□	○	○	○	–	○	○	□	✓	✓	✓	✓	✓	✓
1LA7 08 . . . . □□	○	○	○	–	○	○	□	✓	✓	✓	✓	✓	✓
1LA7 09 . . . . □□	○	○	○	–	○	○	□	✓	✓	✓	✓	✓	✓
1LA7 10 . . . . □□	○	○	○	○	○	○	□	✓	✓	✓	✓	✓	✓
1LA7 11 . . . . □□	○	○	○	○	○	○	□	✓	✓	✓	✓	✓	✓
1LA7 13 . . . . □□	○	○	○	○	○	○	□	✓	✓	✓	✓	✓	✓
1LA7 16 . . . . □□	○	○	○	○	○	○	□	✓	✓	✓	✓	✓	✓
1LA5 18 . . . . □□	○	○	○	○	○	○	□	✓ <sup>4)</sup>	✓	✓	–	–	–
1LA5 20 . . . . □□	○	○	○	○	○	○	□	✓ <sup>4)</sup>	✓	✓	–	–	–
1LA5 22 . . . . □□	○	○	○	○	○	○	□	✓ <sup>4)</sup>	✓	✓	–	–	–

- Standard version
- Without additional charge
- ✓ With additional charge
- Not possible

Order other voltages with voltage code **9** in the penultimate position and the corresponding order code (see “Special versions” in the “Selection and ordering data” under “Voltages”).

Order other types of construction with type of construction code **9** in the final position and the corresponding order code (see “Special versions” in the “Selection and ordering data” under “Types of construction”).

<sup>1)</sup> For connection to 230 V, parallel supply cables are necessary (see catalog part 0 “Introduction”, “Connection, circuit and connection box”).

<sup>2)</sup> 1LA5 183-... to 1LA5 223-... motors (motor series 1LA5, frame size 180 M to 225 M) can be supplied with two additional eyebolts; specify supplement **-Z** and order code **K32**.

<sup>3)</sup> The “Second shaft extension” option, order code **K16** is not possible.

<sup>4)</sup> Type of construction IM V3 is only possible using type of construction code **9** and order code **M1G**.

# IEC Squirrel-Cage Motors

## Standard motors up to frame size 315 L

Self-ventilated energy-saving motors with improved efficiency – Aluminum series 1LA7/1LA5

### Selection and ordering data (continued)

Order No.	Locked-rotor torque	Locked-rotor current	Breakdown torque	Torque class	Moment of inertia	Noise at rated output	
	with direct starting torque	as multiple of rated current	torque			Measuring surface sound pressure level at 50 Hz	Sound pressure level at 50 Hz
▶ Phase-out model	$T_{LR}/T_{rated}$	$I_{LR}/I_{rated}$	$T_B/T_{rated}$	CL	$J$ kgm <sup>2</sup>	$L_{pFA}$ dB(A)	$L_{WA}$ dB(A)
<b>2-pole, 3000 rpm at 50 Hz, 3600 rpm at 60 Hz, temperature class 155 (F), IP55 degree of protection</b>							
<b>1LA7 050-2AA□□</b>	2	3.7	2.3	16	0.00015	41	52
<b>1LA7 053-2AA□□</b>	2.1	3.7	2.4	16	0.00015	41	52
<b>1LA7 060-2AA□□</b>	2	3.7	2.2	16	0.00018	49	60
<b>1LA7 063-2AA□□</b>	2	4	2.2	16	0.00022	49	60
<b>1LA7 070-2AA□□</b>	2.3	3.5	2.3	16	0.00029	52	63
<b>1LA7 073-2AA□□</b>	2.5	4.3	2.6	16	0.00041	52	63
<b>1LA7 080-2AA□□</b>	2.3	5.6	2.4	16	0.00079	56	67
<b>1LA7 083-2AA□□</b>	2.6	6.1	2.7	16	0.001	56	67
<b>1LA7 090-2AA□□</b>	2.4	5.5	2.7	16	0.0014	62	74
<b>1LA7 096-2AA□□</b>	2.8	6.3	3.1	16	0.0018	62	74
▶ 1LA7 106-2AA□□	2.8	6.8	3	16	0.0035	62	74
▶ 1LA7 113-2AA□□	2.6	7.2	2.9	16	0.0059	63	75
▶ 1LA7 130-2AA□□	2	5.9	2.8	16	0.015	68	80
▶ 1LA7 131-2AA□□	2.3	6.9	3	16	0.019	68	80
▶ 1LA7 163-2AA□□	2.1	6.5	2.9	16	0.034	70	82
▶ 1LA7 164-2AA□□	2.2	6.6	3	16	0.043	70	82
▶ 1LA7 166-2AA□□	2.4	7	3.1	16	0.051	70	82
<b>1LA5 183-2AA□□</b>	2.5	6.9	3.2	16	0.077	70	83
<b>1LA5 206-2AA□□</b>	2.4	7.2	2.8	16	0.14	71	84
<b>1LA5 207-2AA□□</b>	2.4	7.7	2.8	16	0.16	71	84
<b>1LA5 223-2AA□□</b>	2.8	7.7	3.4	16	0.2	71	84

- ▶ The Order No. for 1LA7 motors marked with this symbol are phase-out models.

1LE1 motors are the successors.

For additional information see catalog part 1 "New Generation 1LE1/1PC1" under "Self-ventilated energy-saving motors with improved efficiency" Pages 1/18 to 1/21 or under "General Line motors with shorter delivery time" (defined versions - voltages, types of construction, motor protection and location of the connection boxes) Pages 1/8 to 1/17.

# IEC Squirrel-Cage Motors

## Standard motors up to frame size 315 L

Self-ventilated energy-saving motors with improved efficiency – Aluminum series 1LA7/1LA5

### Selection and ordering data (continued)

Rated output at		Frame size	Operating values at rated output							Order No.	Price	Weight
50 Hz	60 Hz		Rated speed at 50 Hz	Rated torque at 50 Hz	Efficiency Class according to CEMEP	Efficiency at 50 Hz 4/4-load	Efficiency at 50 Hz 3/4-load	Power factor at 50 Hz 4/4-load	Rated current at 400 V, 50 Hz			
$P_{rated}$ kW	$P_{rated}$ kW	FS	$n_{rated}$ rpm	$T_{rated}$ Nm		$\eta_{rated}$ %	$\eta_{rated}$ %	$\cos\phi_{rated}$	$I_{rated}$ A	► Phase-out model	<i>m</i> kg	
<b>4-pole, 1500 rpm at 50 Hz, 1800 rpm at 60 Hz, temperature class 155 (F), IP55 degree of protection</b>												
0.06	0.07	56 M	1350	0.42		56	55	0.77	0.2	<b>1LA7 050-4AB□□</b>	3	
0.09	0.11	56 M	1350	0.64		58	57	0.77	0.29	<b>1LA7 053-4AB□□</b>	3	
0.12	0.14	63 M	1350	0.85		55	54	0.75	0.42	<b>1LA7 060-4AB□□</b>	3.5	
0.18	0.21	63 M	1350	1.3		59	60	0.76	0.58	<b>1LA7 063-4AB□□</b>	4.1	
0.25	0.29	71 M	1350	1.8		60	60	0.78	0.77	<b>1LA7 070-4AB□□</b>	4.8	
0.37	0.43	71 M	1370	2.6		65	65	0.78	1.06	<b>1LA7 073-4AB□□</b>	6	
0.55	0.63	80 M	1395	3.8		67	67	0.81	1.46	<b>1LA7 080-4AA□□</b>	9	
0.75	0.86	80 M	1395	5.1		72	72	0.8	1.91	<b>1LA7 083-4AA□□</b>	10	
1.1	1.3	90 S	1415	7.4		77	77	0.81	2.55	<b>1LA7 090-4AA□□</b>	13	
1.5	1.75	90 L	1420	10	EFF2	79	79	0.81	3.4	<b>1LA7 096-4AA□□</b>	15.6	
2.2	2.55	100 L	1420	15	EFF2	82	82.5	0.82	4.7	► 1LA7 106-4AA□□	21	
3	3.45	100 L	1420	20	EFF2	83	83.5	0.82	6.4	► 1LA7 107-4AA□□	24	
4	4.6	112 M	1440	27	EFF2	85	85.5	0.83	8.2	► 1LA7 113-4AA□□	31	
5.5	6.3	132 S	1455	36	EFF2	86	86	0.81	11.4	► 1LA7 130-4AA□□	41	
7.5	8.6	132 M	1455	49	EFF2	87	87.5	0.82	15.2	► 1LA7 133-4AA□□	49	
11	12.6	160 M	1460	72	EFF2	88.5	89	0.84	21.5	► 1LA7 163-4AA□□	73	
15	17.3	160 L	1460	98	EFF2	90	90.2	0.84	28.5	► 1LA7 166-4AA□□	85	
18.5	21.3	180 M	1460	121	EFF2	90.5	90.5	0.83	35.5 <sup>1)</sup>	<b>1LA5 183-4AA□□</b>	113	
22	25.3	180 L	1460	144	EFF2	91.2	91.2	0.84	41.5 <sup>1)</sup>	<b>1LA5 186-4AA□□</b>	123	
30	34.5	200 L	1465	196	EFF2	91.8	91.8	0.86	55	<b>1LA5 207-4AA□□</b>	157	
37	42.5	225 NO	1470	240	EFF2	92.9	92.9	0.87	66 <sup>1)</sup>	<b>1LA5 220-4AA□□</b>	206	
45	52	225 M	1470	292	EFF2	93.4	93.4	0.87	80 <sup>1)</sup>	<b>1LA5 223-4AA□□</b>	232	

### Order No. supplements

Motor type	Penultimate position: Voltage code						Final position: Type of construction code						
	50 Hz			60 Hz			Without flange	With flange		With standard flange		With special flange	
	230 VΔ/400 VY	400 VΔ/690 VY	500 VY	500 VΔ	460 VY	460 VΔ (see "Introduction" for outputs at 60 Hz)	IM B3/6/7/8, IM V6, IM V5 without protective cover	IM B5, IM V1 without protective cover <sup>2)</sup>	IM V1 with protective cover <sup>2)3)</sup>	IM B35	IM B14, IM V19, IM V18 without protective cover	IM B34	IM B14, IM V19, IM V18 without protective cover
	<b>1</b>	<b>6</b>	<b>3</b>	<b>5</b>	<b>1</b>	<b>6</b>	<b>0</b>	<b>1</b>	<b>4</b>	<b>6</b>	<b>2</b>	<b>7</b>	<b>3</b>
<b>1LA7 05</b> . . . . □□	○	○	○	–	○	○	□	✓	–	✓	✓	✓	✓
<b>1LA7 06</b> . . . . □□	○	○	○	–	○	○	□	✓	✓	✓	✓	✓	✓
<b>1LA7 07</b> . . . . □□	○	○	○	–	○	○	□	✓	✓	✓	✓	✓	✓
<b>1LA7 08</b> . . . . □□	○	○	○	–	○	○	□	✓	✓	✓	✓	✓	✓
<b>1LA7 09</b> . . . . □□	○	○	○	–	○	○	□	✓	✓	✓	✓	✓	✓
<b>1LA7 10</b> . . . . □□	○	○	○	○	○	○	□	✓	✓	✓	✓	✓	✓
<b>1LA7 11</b> . . . . □□	○	○	○	○	○	○	□	✓	✓	✓	✓	✓	✓
<b>1LA7 13</b> . . . . □□	○	○	○	○	○	○	□	✓	✓	✓	✓	✓	✓
<b>1LA7 16</b> . . . . □□	○	○	○	○	○	○	□	✓	✓	✓	✓	✓	✓
<b>1LA5 18</b> . . . . □□	○	○	○	○	○	○	□	✓ <sup>4)</sup>	✓	✓	–	–	–
<b>1LA5 20</b> . . . . □□	○	○	○	○	○	○	□	✓ <sup>4)</sup>	✓	✓	–	–	–
<b>1LA5 22</b> . . . . □□	○	○	○	○	○	○	□	✓ <sup>4)</sup>	✓	✓	–	–	–

- Standard version
- Without additional charge
- ✓ With additional charge
- Not possible

Order other voltages with voltage code **9** in the penultimate position and the corresponding order code (see "Special versions" in the "Selection and ordering data" under "Voltages").

Order other types of construction with type of construction code **9** in the final position and the corresponding order code (see "Special versions" in the "Selection and ordering data" under "Types of construction").

<sup>1)</sup> For connection to 230 V, parallel supply cables are necessary (see catalog part 0 "Introduction", "Connection, circuit and connection box").  
<sup>2)</sup> 1LA5 183-... to 1LA5 223-... motors (motor series 1LA5, frame size 180 M to 225 M) can be supplied with two additional eyebolts; specify supplement **-Z** and order code **K32**.

<sup>3)</sup> The "Second shaft extension" option, order code **K16** is not possible.  
<sup>4)</sup> Type of construction IM V3 is only possible using type of construction code **9** and order code **M1G**.

# IEC Squirrel-Cage Motors

## Standard motors up to frame size 315 L

Self-ventilated energy-saving motors with improved efficiency – Aluminum series 1LA7/1LA5

### Selection and ordering data (continued)

Order No.	Locked-rotor torque	Locked-rotor current	Breakdown torque	Torque class	Moment of inertia	Noise at rated output	
	with direct starting as multiple of rated torque	as multiple of rated current	torque	CL	$J$	Measuring surface sound pressure level at 50 Hz	Sound pressure level at 50 Hz
	$T_{LR}/T_{rated}$	$I_{LR}/I_{rated}$	$T_B/T_{rated}$		$J$	$L_{pA}$	$L_{WA}$
					kgm <sup>2</sup>	dB(A)	dB(A)
▶ Phase-out model							
<b>4-pole, 1500 rpm at 50 Hz, 1800 rpm at 60 Hz, temperature class 155 (F), IP55 degree of protection</b>							
<b>1LA7 050-4AB□□</b>	1.9	2.6	1.9	13	0.00027	42	53
<b>1LA7 053-4AB□□</b>	1.9	2.6	1.9	13	0.00027	42	53
<b>1LA7 060-4AB□□</b>	1.9	2.8	2	13	0.00029	42	53
<b>1LA7 063-4AB□□</b>	1.9	3	1.9	13	0.00037	42	53
<b>1LA7 070-4AB□□</b>	1.9	3	1.9	13	0.00052	44	55
<b>1LA7 073-4AB□□</b>	1.9	3.3	2.1	13	0.00077	44	55
<b>1LA7 080-4AA□□</b>	2.2	3.9	2.2	16	0.0014	47	58
<b>1LA7 083-4AA□□</b>	2.3	4.2	2.3	16	0.0017	47	58
<b>1LA7 090-4AA□□</b>	2.3	4.6	2.4	16	0.0024	50	62
<b>1LA7 096-4AA□□</b>	2.4	5.3	2.6	16	0.0033	50	62
▶ 1LA7 106-4AA□□	2.5	5.6	2.8	16	0.0047	56	68
▶ 1LA7 107-4AA□□	2.7	5.6	3	16	0.0055	56	68
▶ 1LA7 113-4AA□□	2.7	6	3	16	0.012	53	65
▶ 1LA7 130-4AA□□	2.5	6.3	3.1	16	0.018	62	74
▶ 1LA7 133-4AA□□	2.7	6.7	3.2	16	0.023	62	74
▶ 1LA7 163-4AA□□	2.2	6.2	2.7	16	0.043	66	78
▶ 1LA7 166-4AA□□	2.6	6.5	3	16	0.055	66	78
<b>1LA5 183-4AA□□</b>	2.3	7.5	3	16	0.13	63	76
<b>1LA5 186-4AA□□</b>	2.3	7.5	3	16	0.15	63	76
<b>1LA5 207-4AA□□</b>	2.6	7	3.2	16	0.24	65	78
<b>1LA5 220-4AA□□</b>	2.8	7	3.2	16	0.32	65	78
<b>1LA5 223-4AA□□</b>	2.8	7.7	3.3	16	0.36	65	78

- ▶ The Order No. for 1LA7 motors marked with this symbol are phase-out models.  
1LE1 motors are the successors.  
For additional information see catalog part 1 "New Generation 1LE1/1PC1" under "Self-ventilated energy-saving motors with improved efficiency" Pages 1/18 to 1/21 or under "General Line motors with shorter delivery time" (defined versions - voltages, types of construction, motor protection and location of the connection boxes) Pages 1/8 to 1/17.

# IEC Squirrel-Cage Motors

## Standard motors up to frame size 315 L

Self-ventilated energy-saving motors with improved efficiency – Aluminum series 1LA7/1LA5

### Selection and ordering data (continued)

Rated output at		Frame size	Operating values at rated output						Order No.	Price	Weight
50 Hz	60 Hz		Rated speed at 50 Hz	Rated torque at 50 Hz	Efficiency Class according to CEMEP	Efficiency at 50 Hz 4/4-load	Efficiency at 50 Hz 3/4-load	Power factor at 50 Hz 4/4-load			
$P_{rated}$ kW	$P_{rated}$ kW	FS	$n_{rated}$ rpm	$T_{rated}$ Nm	$\eta_{rated}$ %	$\eta_{rated}$ %	$\cos\phi_{rated}$	$I_{rated}$ A	► Phase-out model	$m$ kg	
<b>6-pole, 1000 rpm at 50 Hz, 1200 rpm at 60 Hz, temperature class 155 (F), IP55 degree of protection</b>											
0.09	0.1	63 M	850	1	45	41.5	0.66	0.44	1LA7 063-6AB□□	4.1	
0.18	0.21	71 M	850	2	53	54.5	0.68	0.72	1LA7 070-6AA□□	5	
0.25	0.29	71 M	830	2.8	60	58.5	0.76	0.79	1LA7 073-6AA□□	6.3	
0.37	0.43	80 M	920	3.8	62	60.5	0.72	1.2	1LA7 080-6AA□□	9	
0.55	0.63	80 M	910	5.8	67	66.5	0.74	1.6	1LA7 083-6AA□□	10	
0.75	0.86	90 S	915	7.8	69	69	0.76	2.05	1LA7 090-6AA□□	12.5	
1.1	1.3	90 L	915	11	72	72	0.77	2.85	1LA7 096-6AA□□	15.7	
1.5	1.75	100 L	925	15	74	74	0.75	3.9	► 1LA7 106-6AA□□	21	
2.2	2.55	112 M	940	22	78	78.5	0.78	5.2	► 1LA7 113-6AA□□	26	
3	3.45	132 S	950	30	79	79.5	0.76	7.2	► 1LA7 130-6AA□□	38	
4	4.6	132 M	950	40	80.5	80.5	0.76	9.4	► 1LA7 133-6AA□□	44	
5.5	6.3	132 M	950	55	83	83	0.76	12.6	► 1LA7 134-6AA□□	52	
7.5	8.6	160 M	960	75	86	86	0.74	17	► 1LA7 163-6AA□□	74	
11	12.6	160 L	960	109	87.5	87.5	0.74	24.5	► 1LA7 166-6AA□□	95	
15	18	180 L	970	148	89.5	89.5	0.77	31.5	1LA5 186-6AA□□	126	
18.5	22	200 L	975	181	90.2	90.2	0.77	38.5	1LA5 206-6AA□□	161	
22	26.5	200 L	975	215	90.8	90.8	0.77	45.5	1LA5 207-6AA□□	183	
30	36	225 M	978	293	91.8	91.8	0.77	61 <sup>1)</sup>	1LA5 223-6AA□□	214	

### Order No. supplements

Motor type	Penultimate position: Voltage code					Final position: Type of construction code							
	50 Hz		60 Hz			Without flange	With flange		With standard flange		With special flange		
	230 VΔ/400 VY	400 VΔ/690 VY	500 VY	500 VΔ	460 VY (see "Introduction" for outputs at 60 Hz)	IM B3/6/7/8, IM V6, IM V5 without protective cover	IM B5, IM V1 without protective cover <sup>2)</sup>	IM V1 with protective cover <sup>2)3)</sup>	IM B35	IM B14, IM V19, IM V18 without protective cover	IM B34	IM B14, IM V19, IM V18 without protective cover	
	<b>1</b>	<b>6</b>	<b>3</b>	<b>5</b>	<b>1</b>	<b>6</b>	<b>0</b>	<b>1</b>	<b>4</b>	<b>6</b>	<b>2</b>	<b>7</b>	<b>3</b>
1LA7 05 . . . . □□	○	○	○	–	○	○	□	✓	–	✓	✓	✓	✓
1LA7 06 . . . . □□	○	○	○	–	○	○	□	✓	✓	✓	✓	✓	✓
1LA7 07 . . . . □□	○	○	○	–	○	○	□	✓	✓	✓	✓	✓	✓
1LA7 08 . . . . □□	○	○	○	–	○	○	□	✓	✓	✓	✓	✓	✓
1LA7 09 . . . . □□	○	○	○	–	○	○	□	✓	✓	✓	✓	✓	✓
1LA7 10 . . . . □□	○	○	○	○	○	○	□	✓	✓	✓	✓	✓	✓
1LA7 11 . . . . □□	○	○	○	○	○	○	□	✓	✓	✓	✓	✓	✓
1LA7 13 . . . . □□	○	○	○	○	○	○	□	✓	✓	✓	✓	✓	✓
1LA7 16 . . . . □□	○	○	○	○	○	○	□	✓	✓	✓	✓	✓	✓
1LA5 18 . . . . □□	○	○	○	○	○	○	□	✓ <sup>4)</sup>	✓	✓	–	–	–
1LA5 20 . . . . □□	○	○	○	○	○	○	□	✓ <sup>4)</sup>	✓	✓	–	–	–
1LA5 22 . . . . □□	○	○	○	○	○	○	□	✓ <sup>4)</sup>	✓	✓	–	–	–

- Standard version
- Without additional charge
- ✓ With additional charge
- Not possible

Order other voltages with voltage code **9** in the penultimate position and the corresponding order code (see "Special versions" in the "Selection and ordering data" under "Voltages").

Order other types of construction with type of construction code **9** in the final position and the corresponding order code (see "Special versions" in the "Selection and ordering data" under "Types of construction").

<sup>1)</sup> For connection to 230 V, parallel supply cables are necessary (see catalog part 0 "Introduction", "Connection, circuit and connection box").  
<sup>2)</sup> 1LA5 183-... to 1LA5 223-... motors (motor series 1LA5, frame size 180 M to 225 M) can be supplied with two additional eyebolts; specify supplement **-Z** and order code **K32**.

<sup>3)</sup> The "Second shaft extension" option, order code **K16** is not possible.  
<sup>4)</sup> Type of construction IM V3 is only possible using type of construction code **9** and order code **M1G**.



# IEC Squirrel-Cage Motors

## Standard motors up to frame size 315 L

Self-ventilated energy-saving motors with improved efficiency – Aluminum series 1LA7/1LA5

### Selection and ordering data (continued)

Order No.	Locked-rotor torque	Locked-rotor current	Breakdown torque	Torque class	Moment of inertia	Noise at rated output	
	with direct starting as multiple of rated torque	as multiple of rated current	torque			Measuring surface sound pressure level at 50 Hz	Sound pressure level at 50 Hz
	$T_{LR}/T_{rated}$	$I_{LR}/I_{rated}$	$T_B/T_{rated}$	CL	$J$ kgm <sup>2</sup>	$L_{p(A)}$ dB(A)	$L_{WA}$ dB(A)
▶ Phase-out model							
<b>6-pole, 1000 rpm at 50 Hz, 1200 rpm at 60 Hz, temperature class 155 (F), IP55 degree of protection</b>							
<b>1LA7 063-6AB□□</b>	1.8	2	1.9	13	0.00037	39	50
<b>1LA7 070-6AA□□</b>	2.1	2.3	1.9	16	0.00055	39	50
<b>1LA7 073-6AA□□</b>	2.2	2.7	2	16	0.0008	39	50
<b>1LA7 080-6AA□□</b>	1.9	3.1	2.1	16	0.0014	40	51
<b>1LA7 083-6AA□□</b>	2.1	3.4	2.2	16	0.0017	40	51
<b>1LA7 090-6AA□□</b>	2.2	3.7	2.2	16	0.0024	43	55
<b>1LA7 096-6AA□□</b>	2.3	3.8	2.3	16	0.0033	43	55
▶ 1LA7 106-6AA□□	2.3	4	2.3	16	0.0047	47	59
▶ 1LA7 113-6AA□□	2.2	4.6	2.5	16	0.0091	52	64
▶ 1LA7 130-6AA□□	1.9	4.2	2.2	16	0.015	63	75
▶ 1LA7 133-6AA□□	2.1	4.5	2.4	16	0.019	63	75
▶ 1LA7 134-6AA□□	2.3	5	2.6	16	0.025	63	75
▶ 1LA7 163-6AA□□	2.1	4.6	2.5	16	0.044	66	78
▶ 1LA7 166-6AA□□	2.3	4.8	2.6	16	0.063	66	78
<b>1LA5 186-6AA□□</b>	2	5.2	2.4	16	0.15	66	78
<b>1LA5 206-6AA□□</b>	2.7	5.5	2.8	16	0.24	66	78
<b>1LA5 207-6AA□□</b>	2.8	5.5	2.9	16	0.28	66	78
<b>1LA5 223-6AA□□</b>	2.8	5.7	2.9	16	0.36	66	78

- ▶ The Order No. for 1LA7 motors marked with this symbol are phase-out models.

1LE1 motors are the successors.

For additional information see catalog part 1 "New Generation 1LE1/1PC1" under "Self-ventilated energy-saving motors with improved efficiency" Pages 1/18 to 1/21 or under "General Line motors with shorter delivery time" (defined versions - voltages, types of construction, motor protection and location of the connection boxes) Pages 1/8 to 1/17.

# IEC Squirrel-Cage Motors

## Standard motors up to frame size 315 L

Self-ventilated energy-saving motors with improved efficiency – Aluminum series 1LA7/1LA5

### Selection and ordering data (continued)

Rated output at		Frame size	Operating values at rated output						Order No.	Price	Weight
50 Hz	60 Hz		Rated speed at 50 Hz	Rated torque at 50 Hz	Efficiency Class according to CEMEP	Efficiency at 50 Hz 4/4-load	Efficiency at 50 Hz 3/4-load	Power factor at 50 Hz 4/4-load			
$P_{rated}$ kW	$P_{rated}$ kW	FS	$n_{rated}$ rpm	$T_{rated}$ Nm	$\eta_{rated}$ %	$\eta_{rated}$ %	$\cos\phi_{rated}$	$I_{rated}$ A	► Phase-out model	$m$ kg	
<b>8-pole, 750 rpm at 50 Hz, 900 rpm at 60 Hz, temperature class 155 (F), IP55 degree of protection</b>											
0.09	0.1	71 M	630	1.4	53	54.5	0.68	0.36	<b>1LA7 070-8AB□□</b>	6.3	
0.12	0.14	71 M	645	1.8	53	49.5	0.64	0.51	<b>1LA7 073-8AB□□</b>	6.3	
0.18	0.21	80 M	675	2.5	51	49.5	0.68	0.75	<b>1LA7 080-8AB□□</b>	9	
0.25	0.29	80 M	685	3.5	55	50.5	0.64	1.02	<b>1LA7 083-8AB□□</b>	10	
0.37	0.43	90 S	675	5.2	63	62	0.75	1.14	<b>1LA7 090-8AB□□</b>	10.5	
0.55	0.63	90 L	675	7.8	66	65	0.76	1.58	<b>1LA7 096-8AB□□</b>	13.2	
0.75	0.86	100 L	680	11	66	65	0.76	2.15	► 1LA7 106-8AB□□	19	
1.1	1.3	100 L	680	15	72	72	0.76	2.9	► 1LA7 107-8AB□□	22	
1.5	1.75	112 M	705	20	74	74	0.76	3.85	► 1LA7 113-8AB□□	24	
2.2	2.55	132 S	700	30	75	75	0.74	5.7	► 1LA7 130-8AB□□	38	
3	3.45	132 M	700	41	77	77.5	0.74	7.6	► 1LA7 133-8AB□□	44	
4	4.6	160 M	715	53	80	80	0.72	10	► 1LA7 163-8AB□□	64	
5.5	6.3	160 M	710	74	83.5	83.5	0.73	13	► 1LA7 164-8AB□□	74	
7.5	8.6	160 L	715	100	85.5	85.5	0.72	17.6	► 1LA7 166-8AB□□	94	
11	13.2	180 L	725	145	87	87	0.75	24.5	<b>1LA5 186-8AB□□</b>	128	
15	18	200 L	725	198	87.5	87.5	0.78	31.5	<b>1LA5 207-8AB□□</b>	176	
18.5	22	225 NO	725	244	89.2	89.2	0.79	38	<b>1LA5 220-8AB□□</b>	184	
22	26.5	225 M	725	290	90.6	90.6	0.79	44.5	<b>1LA5 223-8AB□□</b>	214	

### Order No. supplements

Motor type	Penultimate position: Voltage code						Final position: Type of construction code						
	50 Hz		60 Hz				Without flange	With flange		With standard flange		With special flange	
	230 VΔ/400 VY	400 VΔ/690 VY	500 VY	500 VΔ	460 VY	460 VΔ	IM B3/6/7/8, IM V6, IM V5 without protective cover	IM B5, IM V1 without protective cover <sup>1)</sup>	IM V1 with protective cover <sup>1) 2)</sup>	IM B35	IM B14, IM V19, IM V18 without protective cover	IM B34	IM B14, IM V19, IM V18 without protective cover
	<b>1</b>	<b>6</b>	<b>3</b>	<b>5</b>	<b>1</b>	<b>6</b>	<b>0</b>	<b>1</b>	<b>4</b>	<b>6</b>	<b>2</b>	<b>7</b>	<b>3</b>
1LA7 05 . . . . □□	○	○	○	–	○	○	□	✓	–	✓	✓	✓	✓
1LA7 06 . . . . □□	○	○	○	–	○	○	□	✓	✓	✓	✓	✓	✓
1LA7 07 . . . . □□	○	○	○	–	○	○	□	✓	✓	✓	✓	✓	✓
1LA7 08 . . . . □□	○	○	○	–	○	○	□	✓	✓	✓	✓	✓	✓
1LA7 09 . . . . □□	○	○	○	–	○	○	□	✓	✓	✓	✓	✓	✓
1LA7 10 . . . . □□	○	○	○	○	○	○	□	✓	✓	✓	✓	✓	✓
1LA7 11 . . . . □□	○	○	○	○	○	○	□	✓	✓	✓	✓	✓	✓
1LA7 13 . . . . □□	○	○	○	○	○	○	□	✓	✓	✓	✓	✓	✓
1LA7 16 . . . . □□	○	○	○	○	○	○	□	✓	✓	✓	✓	✓	✓
1LA5 18 . . . . □□	○	○	○	○	○	○	□	✓ <sup>3)</sup>	✓	✓	–	–	–
1LA5 20 . . . . □□	○	○	○	○	○	○	□	✓ <sup>3)</sup>	✓	✓	–	–	–
1LA5 22 . . . . □□	○	○	○	○	○	○	□	✓ <sup>3)</sup>	✓	✓	–	–	–

- Standard version
- Without additional charge
- ✓ With additional charge
- Not possible

Order other voltages with voltage code **9** in the penultimate position and the corresponding order code (see "Special versions" in the "Selection and ordering data" under "Voltages").

Order other types of construction with type of construction code **9** in the final position and the corresponding order code (see "Special versions" in the "Selection and ordering data" under "Types of construction").

<sup>1)</sup> 1LA5 183-... to 1LA5 223-... motors (motor series 1LA5, frame size 180 M to 225 M) can be supplied with two additional eyebolts; specify supplement **-Z** and order code **K32**.

<sup>2)</sup> The "Second shaft extension" option, order code **K16** is not possible.

<sup>3)</sup> Type of construction IM V3 is only possible using type of construction code **9** and order code **M1G**.

# IEC Squirrel-Cage Motors

## Standard motors up to frame size 315 L

Self-ventilated energy-saving motors with improved efficiency – Aluminum series 1LA7/1LA5

### Selection and ordering data (continued)

Order No.	Locked-rotor torque	Locked-rotor current	Breakdown torque	Torque class	Moment of inertia	Noise at rated output	
	with direct starting as multiple of rated torque	as multiple of rated current	torque	CL	$J$ kgm <sup>2</sup>	Measuring surface sound pressure level at 50 Hz $L_{p(A)}$ dB(A)	Sound pressure level at 50 Hz $L_{WA}$ dB(A)
	$T_{LR}/T_{rated}$	$I_{LR}/I_{rated}$	$T_B/T_{rated}$				
▶ Phase-out model							
<b>8-pole, 750 rpm at 50 Hz, 900 rpm at 60 Hz, temperature class 155 (F), IP55 degree of protection</b>							
<b>1LA7 070-8AB□□</b>	1.9	2.2	1.7	13	0.0008	36	47
<b>1LA7 073-8AB□□</b>	2.2	2.2	2	13	0.0008	36	47
<b>1LA7 080-8AB□□</b>	1.7	2.3	1.9	13	0.0014	41	52
<b>1LA7 083-8AB□□</b>	2	2.6	2.2	13	0.0017	41	52
<b>1LA7 090-8AB□□</b>	1.6	2.9	1.8	13	0.0023	41	53
<b>1LA7 096-8AB□□</b>	1.7	3	1.9	13	0.0031	41	53
▶ 1LA7 106-8AB□□	1.6	3	1.9	13	0.0051	45	57
▶ 1LA7 107-8AB□□	1.8	3.3	2.1	13	0.0063	45	57
▶ 1LA7 113-8AB□□	1.8	3.7	2.1	13	0.013	49	61
▶ 1LA7 130-8AB□□	1.9	3.9	2.3	13	0.014	53	65
▶ 1LA7 133-8AB□□	2.1	4.1	2.4	13	0.019	53	65
▶ 1LA7 163-8AB□□	2.2	4.5	2.6	13	0.036	63	75
▶ 1LA7 164-8AB□□	2.3	4.7	2.7	13	0.046	63	75
▶ 1LA7 166-8AB□□	2.7	5.3	3	13	0.064	63	75
<b>1LA5 186-8AB□□</b>	2	5	2.2	13	0.21	60	73
<b>1LA5 207-8AB□□</b>	2.1	5	2.2	13	0.37	58	71
<b>1LA5 220-8AB□□</b>	2.1	4.5	2.2	13	0.37	58	71
<b>1LA5 223-8AB□□</b>	2.2	4.8	2.3	13	0.45	58	71

- ▶ The Order No. for 1LA7 motors marked with this symbol are phase-out models.  
1LE1 motors are the successors.  
For additional information see catalog part 1 "New Generation 1LE1/1PC1" under "Self-ventilated energy-saving motors with improved efficiency" Pages 1/18 to 1/21.

# IEC Squirrel-Cage Motors

## Standard motors up to frame size 315 L

Self-ventilated energy-saving motors with improved efficiency – Aluminum series 1LA7/1LA5

### Selection and ordering data (continued)

Rated output at 50 Hz,		Frame size	Rated speed at 50 Hz,		Rated torque at 50 Hz,		Efficiency at 50 Hz 4/4-load		Power factor at 50 Hz 4/4-load		Rated current at 400 V, 50 Hz		Order No.	Price	Weight motor
1500 rpm	3000 rpm		1500 rpm	3000 rpm	1500 rpm	3000 rpm	1500 rpm	3000 rpm	1500 rpm	3000 rpm	1500 rpm	3000 rpm			
$P_{\text{rated}}$ kW	kW	FS	$n_{\text{rated}}$ rpm	rpm	$T_{\text{rated}}$ Nm	Nm	$\eta_{\text{rated}}$ %	%	$\cos\phi_{\text{rated}}$	$I_{\text{rated}}$ A	A			$m$ kg	
<b>4/2-pole, 1500/3000 rpm at 50 Hz, temperature class 155 (F), IP55 degree of protection, double pole-changing for constant load torque with one winding connected in Dahlander circuit</b>															
0.1	0.15	63 M	1330	2650	0.72	0.54	45	52	0.79	0.82	0.41	0.51	<b>1LA7 060-0AAQQ</b>		3.5
0.15	0.2	63 M	1330	2750	1.1	0.7	45	57	0.71	0.73	0.68	0.7	<b>1LA7 063-0AAQQ</b>		4.1
0.21	0.28	71 M	1375	2770	1.5	0.97	59	48	0.73	0.76	0.7	1.1	<b>1LA7 070-0AAQQ</b>		4.8
0.3	0.43	71 M	1390	2780	2.1	1.5	64	58	0.76	0.82	0.89	1.3	<b>1LA7 073-0AAQQ</b>		7
0.48	0.6	80 M	1390	2810	3.3	2	66	64	0.82	0.84	1.25	1.6	<b>1LA7 080-0AAQQ</b>		9
0.7	0.85	80 M	1390	2810	4.8	2.9	69	70	0.84	0.83	1.75	2.1	<b>1LA7 083-0AAQQ</b>		10
1.1	1.4	90 S	1390	2810	7.6	4.8	69	66	0.85	0.85	2.7	3.6	<b>1LA7 090-0AAQQ</b>		13
1.5	1.9	90 L	1410	2860	10	6.4	74	72	0.86	0.85	3.4	4.5	<b>1LA7 096-0AAQQ</b>		15.6
2	2.4	100 L	1410	2870	14	8	81	75	0.84	0.84	4.25	5.5	<b>1LA7 106-0AAQQ</b>		21
2.6	3.1	100 L	1400	2850	18	10	79	74	0.86	0.8	5.5	7.6	<b>1LA7 107-0AAQQ</b>		24
3.7	4.4	112 M	1420	2885	25	15	79	76	0.85	0.8	8	10.5	<b>1LA7 113-0AAQQ</b>		31
4.7	5.9	132 S	1450	2920	31	19	83	80	0.84	0.85	9.7	12.5	<b>1LA7 130-0AAQQ</b>		41
6.5	8	132 M	1450	2930	43	26	82	82.5	0.84	0.84	13.6	16.7	<b>1LA7 133-0AAQQ</b>		50
9.3	11.5	160 M	1455	2930	61	37	86.5	80	0.85	0.89	18.3	23.4	<b>1LA7 163-0AAQQ</b>		74
13	17	160 L	1455	2930	85	55	87.5	87	0.84	0.88	25.6	32	<b>1LA7 166-0AAQQ</b>		92
15	18	180 M	1470	2950	97	58	90	86.5	0.83	0.8	29	37.5	<b>1LA5 183-0AAQQ</b>		113
18	21.5	180 L	1465	2950	117	70	90	87	0.84	0.85	34.5	42	<b>1LA5 186-0AAQQ</b>		123
26	31	200 L	1465	2940	169	101	90.9	86.5	0.86	0.85	48.5	61	<b>1LA5 207-0AAQQ</b>		157

### Order No. supplements

Motor type	Penultimate position: Voltage code				Final position: Type of construction code							
	50 Hz, direct online starting				Without flange		With flange			With standard flange		With special flange
	230 V	400 V	500 V	690 V	IM B3, IM B6/7/8, IM V6/5 without protective cover	IM B5, IM V1 without protective cover <sup>1)</sup>	IM V1 with protective cover <sup>1)2)</sup>	IM B35	IM B14, IM V19, IM V18 without protective cover	IM B34	IM B14, IM V19, IM V18 without protective cover	
<b>1</b>	<b>6</b>	<b>5</b>	<b>0</b>	<b>0</b>	<b>1</b>	<b>4</b>	<b>6</b>	<b>2</b>	<b>7</b>	<b>3</b>		
<b>1LA7 06</b> . . . . <b>QQ</b>	○	○	○	○	□	✓	✓	✓	✓	✓	✓	
<b>1LA7 07</b> . . . . <b>QQ</b>	○	○	○	○	□	✓	✓	✓	✓	✓	✓	
<b>1LA7 08</b> . . . . <b>QQ</b>	○	○	○	○	□	✓	✓	✓	✓	✓	✓	
<b>1LA7 09</b> . . . . <b>QQ</b>	○	○	○	○	□	✓	✓	✓	✓	✓	✓	
<b>1LA7 10</b> . . . . <b>QQ</b>	○	○	○	○	□	✓	✓	✓	✓	✓	✓	
<b>1LA7 11</b> . . . . <b>QQ</b>	○	○	○	○	□	✓	✓	✓	✓	✓	✓	
<b>1LA7 13</b> . . . . <b>QQ</b>	○	○	○	○	□	✓	✓	✓	✓	✓	✓	
<b>1LA7 16</b> . . . . <b>QQ</b>	○	○	○	○	□	✓	✓	✓	✓	✓	✓	
<b>1LA5 18</b> . . . . <b>QQ</b>	○	○	○	○	□	✓ <sup>3)</sup>	✓	✓	–	–	–	
<b>1LA5 20</b> . . . . <b>QQ</b>	○	○	○	○	□	✓ <sup>3)</sup>	✓	✓	–	–	–	

- Standard version
- Without additional charge
- ✓ With additional charge
- Not possible

Order other voltages with voltage code **9** in the penultimate position and the corresponding order code (see “Special versions” in the “Selection and ordering data” under “Voltages”).

Order other types of construction with type of construction code **9** in the final position and the corresponding order code (see “Special versions” in the “Selection and ordering data” under “Types of construction”).

<sup>1)</sup> 1LA5 183-... to 1LA5 207-... motors (motor series 1LA5, frame size 180 M to 200 L) can be supplied with two additional eyebolts; specify supplement **-Z** and order code **K32**.

<sup>2)</sup> The “Second shaft extension” option, order code **K16** is not possible.

<sup>3)</sup> Type of construction IM V3 is only possible using type of construction code **9** and order code **M1G**.

# IEC Squirrel-Cage Motors

## Standard motors up to frame size 315 L

Self-ventilated energy-saving motors with improved efficiency – Aluminum series 1LA7/1LA5

### Selection and ordering data (continued)

Order No.	Locked-rotor torque with direct starting 1500 rpm $T_{LR}/T_{rated}$	Locked-rotor torque as multiple of torque 3000 rpm $T_{LR}/T_{rated}$	Locked-rotor current 1500 rpm $I_{LR}/I_{rated}$	Locked-rotor current 3000 rpm $I_{LR}/I_{rated}$	Breakdown torque 1500 rpm $T_B/T_{rated}$	Breakdown torque 3000 rpm $T_B/T_{rated}$	Torque class CL	Moment of inertia J kgm <sup>2</sup>
<b>4/2-pole, 1500/3000 rpm at 50 Hz, temperature class 155 (F), IP55 degree of protection, double pole-changing for constant load torque with one winding connected in Dahlander circuit</b>								
1LA7 060-0AA□□	1.8	1.8	2.7	2.9	1.8	1.8	10	0.0029
1LA7 063-0AA□□	2	2	3	3.3	2	2	10	0.0004
1LA7 070-0AA□□	1.6	1.6	3	3.1	1.8	1.8	10	0.00052
1LA7 073-0AA□□	1.8	1.8	3.7	3.8	2	2	10	0.00076
1LA7 080-0AA□□	1.7	1.7	3.9	4	2	2	10	0.0014
1LA7 083-0AA□□	1.8	1.8	4.3	4.3	2.1	2.1	10	0.0017
1LA7 090-0AA□□	1.6	1.8	4.2	4.3	1.9	2	13	0.0024
1LA7 096-0AA□□	1.9	1.9	4.9	5.3	2	2.1	13	0.0033
1LA7 106-0AA□□	1.8	1.8	5	5.5	2	2.1	13	0.0048
1LA7 107-0AA□□	2.3	2.4	5.6	5.6	2.4	2.4	13	0.0055
1LA7 113-0AA□□	2	2.2	5.6	5.8	2.2	2.3	13	0.011
1LA7 130-0AA□□	1.7	1.6	6.3	6.5	2.2	2.2	10	0.018
1LA7 133-0AA□□	2	2.1	6.9	7.5	2.5	2.6	10	0.023
1LA7 163-0AA□□	2	1.8	6.7	7.4	2.6	2.4	10	0.043
1LA7 166-0AA□□	2.5	2.8	7.6	8.5	3	3	10	0.06
1LA5 183-0AA□□	2.1	2.2	6.7	7.5	2.7	3.2	13	0.13
1LA5 186-0AA□□	2	2.2	6.4	7.3	2.6	3.1	13	0.15
1LA5 207-0AA□□	2.6	2.6	6.7	7.5	2.8	3.3	13	0.24

See catalog part "Fan motors" for pole-changing motors for quadratic load torque for driving fans.

# IEC Squirrel-Cage Motors

## Standard motors up to frame size 315 L

Self-ventilated energy-saving motors with improved efficiency – Aluminum series 1LA7/1LA5

### Selection and ordering data (continued)

Rated output at 50 Hz, 750 rpm		Frame size		Rated speed at 50 Hz, 750 rpm		Rated torque at 50 Hz, 750 rpm		Efficiency at 50 Hz 4/4-load		Power factor at 50 Hz 4/4-load		Rated current at 400 V, 50 Hz		Order No.	Price	Weight motor
1500 rpm	750 rpm			1500 rpm	750 rpm	1500 rpm	750 rpm	750 rpm	1500 rpm	750 rpm	1500 rpm	750 rpm	1500 rpm			
$P_{\text{rated}}$ kW		FS		$n_{\text{rated}}$ rpm		$T_{\text{rated}}$ Nm		$\eta_{\text{rated}}$ %		$\cos\phi_{\text{rated}}$		$I_{\text{rated}}$ A				$m$ kg
<b>8/4-pole, 750/1500 rpm at 50 Hz, temperature class 155 (F), IP55 degree of protection, double pole-changing for constant load torque with one winding connected in Dahlander circuit</b>																
0.35	0.5	90 S		675	1365	5.1	3.6	60	65	0.71	0.79	1.19	1.41	<b>1LA7 090-0ABQQ</b>		11
0.5	0.7	90 L		675	1380	7.1	4.9	63	62	0.72	0.78	1.6	2.1	<b>1LA7 096-0ABQQ</b>		13.2
0.7	1.1	100 L		690	1380	9.8	7.7	65	61	0.74	0.8	2.1	3.25	<b>1LA7 106-0ABQQ</b>		20
0.9	1.5	100 L		690	1380	13	10	69	67	0.70	0.8	2.7	4.0	<b>1LA7 107-0ABQQ</b>		22
1.4	1.9	112 M		690	1410	19	13	69	70	0.73	0.75	4	5.2	<b>1LA7 113-0ABQQ</b>		25
1.8	3.6	132 S		720	1430	24	24	72	80	0.57	0.9	6.3	7.2	<b>1LA7 130-0ABQQ</b>		41
2.5	5	132 M		720	1430	33	33	73	80	0.6	0.9	8.2	10	<b>1LA7 133-0ABQQ</b>		49
3.5	7	160 M		725	1450	46	46	77	81.5	0.56	0.89	11.7	13.9	<b>1LA7 163-0ABQQ</b>		73
5.6	11	160 L		725	1450	74	72	78	83	0.56	0.89	18.5	21.5	<b>1LA7 166-0ABQQ</b>		91
11	18	180 L		725	1455	144	118	83.5	83.5	0.69	0.87	27.5	35	<b>1LA5 186-0ABQQ</b>		123
17	27	200 L		730	1465	223	177	89	89.5	0.68	0.86	40.5	50.5	<b>1LA5 207-0ABQQ</b>		157

### Order No. supplements

Motor type	Penultimate position: Voltage code				Final position: Type of construction code						
	50 Hz, direct online starting				Without flange	With flange		With standard flange		With special flange	
	230 V	400 V	500 V	690 V	IM B3, IM B6/7/8, IM V6/5 without protective cover	IM B5, IM V1 without protective cover <sup>1)</sup>	IM V1 with protective cover <sup>1) 2)</sup>	IM B35	IM B14, IM V19, IM V18 without protective cover	IM B34	IM B14, IM V19, IM V18 without protective cover
	1	6	5	0	0	1	4	6	2	7	3
<b>1LA7 06</b> . . . . . <b>□□</b>	○	○	○	○	□	✓	✓	✓	✓	✓	✓
<b>1LA7 07</b> . . . . . <b>□□</b>	○	○	○	○	□	✓	✓	✓	✓	✓	✓
<b>1LA7 08</b> . . . . . <b>□□</b>	○	○	○	○	□	✓	✓	✓	✓	✓	✓
<b>1LA7 09</b> . . . . . <b>□□</b>	○	○	○	○	□	✓	✓	✓	✓	✓	✓
<b>1LA7 10</b> . . . . . <b>□□</b>	○	○	○	○	□	✓	✓	✓	✓	✓	✓
<b>1LA7 11</b> . . . . . <b>□□</b>	○	○	○	○	□	✓	✓	✓	✓	✓	✓
<b>1LA7 13</b> . . . . . <b>□□</b>	○	○	○	○	□	✓	✓	✓	✓	✓	✓
<b>1LA7 16</b> . . . . . <b>□□</b>	○	○	○	○	□	✓	✓	✓	✓	✓	✓
<b>1LA5 18</b> . . . . . <b>□□</b>	○	○	○	○	□	✓ <sup>3)</sup>	✓	✓	–	–	–
<b>1LA5 20</b> . . . . . <b>□□</b>	○	○	○	○	□	✓ <sup>3)</sup>	✓	✓	–	–	–

- Standard version
- Without additional charge
- ✓ With additional charge
- Not possible

Order other voltages with voltage code **9** in the penultimate position and the corresponding order code (see "Special versions" in the "Selection and ordering data" under "Voltages").

Order other types of construction with type of construction code **9** in the final position and the corresponding order code (see "Special versions" in the "Selection and ordering data" under "Types of construction").

<sup>1)</sup> 1LA5 183-... to 1LA5 207-... motors (motor series 1LA5, frame size 180 M to 200 L) can be supplied with two additional eyebolts; specify supplement **-Z** and order code **K32**.

<sup>2)</sup> The "Second shaft extension" option, order code **K16** is not possible.

<sup>3)</sup> Type of construction IM V3 is only possible using type of construction code **9** and order code **M1G**.

# IEC Squirrel-Cage Motors

## Standard motors up to frame size 315 L

Self-ventilated energy-saving motors with improved efficiency – Aluminum series 1LA7/1LA5

### Selection and ordering data (continued)

Order No.	Locked-rotor torque with direct starting at 750 rpm $T_{LR}/T_{rated}$	Locked-rotor torque as multiple of current at 1500 rpm $T_{LR}/T_{rated}$	Locked-rotor current at 750 rpm $I_{LR}/I_{rated}$	Locked-rotor current at 1500 rpm $I_{LR}/I_{rated}$	Breakdown torque at 750 rpm $T_B/T_{rated}$	Breakdown torque at 1500 rpm $T_B/T_{rated}$	Torque class CL	Moment of inertia $J$ kgm <sup>2</sup>
<b>8/4-pole, 750/1500 rpm at 50 Hz, temperature class 155 (F), IP55 degree of protection, double pole-changing for constant load torque with one winding connected in Dahlander circuit</b>								
<b>1LA7 090-0AB□□</b>	1.3	1.3	2.5	3.2	1.6	1.6	10	0.0023
<b>1LA7 096-0AB□□</b>	1.4	1.5	3	3.5	1.7	1.8	10	0.0031
<b>1LA7 106-0AB□□</b>	1.7	1.6	3.3	3.5	2	1.9	10	0.0051
<b>1LA7 107-0AB□□</b>	1.8	1.6	3.5	3.6	2	1.9	10	0.0063
<b>1LA7 113-0AB□□</b>	1.4	1.5	3.6	4.4	1.7	1.8	10	0.013
<b>1LA7 130-0AB□□</b>	2	1.3	4.3	5.4	2.3	1.8	10	0.018
<b>1LA7 133-0AB□□</b>	2	1.3	4.3	5.4	2.3	1.8	10	0.023
<b>1LA7 163-0AB□□</b>	2	1.4	4	5.4	2.3	1.8	10	0.043
<b>1LA7 166-0AB□□</b>	2.2	1.7	4.2	5.9	2.4	2	10	0.06
<b>1LA5 186-0AB□□</b>	1.9	2	5.2	6.2	2.2	2.2	13	0.21
<b>1LA5 207-0AB□□</b>	2.4	2.3	5.4	6.6	2.5	2.5	13	0.37

See catalog part "Fan motors" for pole-changing motors for quadratic load torque for driving fans.

# IEC Squirrel-Cage Motors

## Standard motors up to frame size 315 L

Self-ventilated energy-saving motors with high efficiency – Aluminum series 1LA9

### Selection and ordering data

Rated output at 50 Hz	Frame size	Operating values at rated output							Order No.	Price	Weight IM B3 type of construction approx. m kg
		Rated speed at 50 Hz	Rated torque at 50 Hz	Efficiency Class according to CEMEP	Efficiency at 50 Hz 4/4-load	Efficiency at 50 Hz 3/4-load	Power factor at 50 Hz 4/4-load	Rated current at 400 V, 50 Hz			
$P_{\text{rated}}$ kW	FS	$n_{\text{rated}}$ rpm	$T_{\text{rated}}$ Nm		$\eta_{\text{rated}}$ %	$\eta_{\text{rated}}$ %	$\cos\phi_{\text{rated}}$	$I_{\text{rated}}$ A			
<b>2-pole, 3000 rpm at 50 Hz, temperature class 155 (F), IP55 degree of protection, for use according to CEMEP</b>											
0.09	56 M	2830	0.3		70	70	0.76	0.24	<b>1LA9 050-2KAQQ</b>		3
0.12	56 M	2830	0.4		70	70	0.81	0.31	<b>1LA9 053-2KAQQ</b>		3.8
0.18	63 M	2840	0.61		70	70	0.78	0.48	<b>1LA9 060-2KAQQ</b>		4.1
0.25	63 M	2840	0.84		72	72	0.8	0.63	<b>1LA9 063-2KAQQ</b>		5.1
0.37	71 M	2840	1.2		74	74	0.77	0.94	<b>1LA9 070-2KAQQ</b>		6
0.55	71 M	2835	1.9		75	75	0.75	1.42	<b>1LA9 073-2KAQQ</b>		7.2
0.75	80 M	2870	2.5		80	80	0.82	1.66	<b>1LA9 080-2KAQQ</b>		9.8
1.1	80 M	2860	3.7	EFF1	84	84	0.89	2.1	<b>1LA9 083-2KAQQ</b>		12.3
1.5	90 S	2890	5	EFF1	85	85	0.87	2.95	<b>1LA9 090-2KAQQ</b>		15
2.2	90 L	2890	7.3	EFF1	86.5	86.5	0.87	4.2	<b>1LA9 096-2KAQQ</b>		18.6
3	100 L	2890	9.9	EFF1	87	87	0.88	5.7	<b>1LA9 106-2KAQQ</b>		24
4	112 M	2905	13	EFF1	88.5	88.5	0.89	7.3	<b>1LA9 113-2KAQQ</b>		35
5.5	132 S	2930	18	EFF1	89.5	89.5	0.9	9.9	<b>1LA9 130-2KAQQ</b>		43
7.5	132 S	2930	24	EFF1	90.5	90.5	0.92	13	<b>1LA9 131-2KAQQ</b>		56
11	160 M	2945	36	EFF1	91	91	0.9	19.4	<b>1LA9 163-2KAQQ</b>		73
15	160 M	2945	49	EFF1	91.5	91.5	0.9	26.5	<b>1LA9 164-2KAQQ</b>		82
18.5	160 L	2940	60	EFF1	92.3	92.5	0.92	31.5	<b>1LA9 166-2KAQQ</b>		102
22	180 M	2945	71	EFF1	93	93.2	0.89	38.5 <sup>1)</sup>	<b>1LA9 183-2WAQQ</b>		131
30	200 L	2950	97	EFF1	93.5	93.5	0.89	52	<b>1LA9 206-2WAQQ</b>		185
37	200 L	2950	120	EFF1	94	94.1	0.89	64 <sup>1)</sup>	<b>1LA9 207-2WAQQ</b>		214

### Order No. supplements

Motor type	Penultimate position: Voltage code				Final position: Type of construction code							
	50 Hz				Without flange	With flange			With standard flange		With special flange	
	230 VΔ/400 VY	400 VΔ/690 VY	500 VY	500 VΔ	IM B3/6/7/8, IM V6, IM V5 without protective cover	IM B5, IM V1 without protective cover	IM V1 with protective cover <sup>2)</sup>	IM B35	IM B14, IM V19, IM V18 without protective cover	IM B34	IM B14, IM V19, IM V18 without protective cover	
	<b>1</b>	<b>6</b>	<b>3</b>	<b>5</b>	<b>0</b>	<b>1</b>	<b>4</b>	<b>6</b>	<b>2</b>	<b>7</b>	<b>3</b>	
<b>1LA9 05</b> . . . . . <b>QQ</b>	○	○	○	–	□	✓	–	–	✓	✓	✓	
<b>1LA9 06</b> . . . . . <b>QQ</b>	○	○	○	–	□	✓	✓	✓	✓	✓	✓	
<b>1LA9 07</b> . . . . . <b>QQ</b>	○	○	○	–	□	✓	✓	✓	✓	✓	✓	
<b>1LA9 08</b> . . . . . <b>QQ</b>	○	○	○	–	□	✓	✓	✓	✓	✓	✓	
<b>1LA9 09</b> . . . . . <b>QQ</b>	○	○	○	–	□	✓	✓	✓	✓	✓	✓	
<b>1LA9 10</b> . . . . . <b>QQ</b>	○	○	○	○	□	✓	✓	✓	✓	✓	✓	
<b>1LA9 11</b> . . . . . <b>QQ</b>	○	○	○	○	□	✓	✓	✓	✓	✓	✓	
<b>1LA9 13</b> . . . . . <b>QQ</b>	○	○	○	○	□	✓	✓	✓	✓	✓	✓	
<b>1LA9 16</b> . . . . . <b>QQ</b>	○	○	○	○	□	✓	✓	✓	✓	✓	✓	
<b>1LA9 18</b> . . . . . <b>QQ</b>	○	○	○	○	□	✓ <sup>3)</sup>	✓	✓	–	–	–	
<b>1LA9 20</b> . . . . . <b>QQ</b>	○	○	○	○	□	✓ <sup>3)</sup>	✓	✓	–	–	–	

- Standard version
- Without additional charge
- ✓ With additional charge
- Not possible

Order other voltages with voltage code **9** in the penultimate position and the corresponding order code (see "Special versions" in the "Selection and ordering data" under "Voltages").

Order other types of construction with type of construction code **9** in the final position and the corresponding order code (see "Special versions" in the "Selection and ordering data" under "Types of construction").

<sup>1)</sup> For connection to 230 V, parallel supply cables are necessary (see catalog part 0 "Introduction", "Connection, circuit and connection box").

<sup>2)</sup> The "Second shaft extension" option, order code **K16** is not possible.

<sup>3)</sup> Type of construction IM V3 is only possible using type of construction code **9** and order code **M1G**.



# IEC Squirrel-Cage Motors

## Standard motors up to frame size 315 L

Self-ventilated energy-saving motors with high efficiency – Aluminum series 1LA9

### Selection and ordering data (continued)

Order No.	Locked-rotor torque with direct starting torque	Locked-rotor current as multiple of rated current	Breakdown torque torque	Torque class	Moment of inertia	Noise at rated output	
	$T_{LR}/T_{rated}$	$I_{LR}/I_{rated}$	$T_B/T_{rated}$	CL	$J$ kgm <sup>2</sup>	Measuring surface sound pressure level at 50 Hz $L_{pFA}$ dB(A)	Sound pressure level at 50 Hz $L_{WA}$ dB(A)
<b>2-pole, 3000 rpm at 50 Hz, temperature class 155 (F), IP55 degree of protection, for use according to CEMEP</b>							
1LA9 050-2KA□□	3.6	4.5	3	16	0.00015	41	52
1LA9 053-2KA□□	3.2	4.3	2.8	16	0.0002	41	52
1LA9 060-2KA□□	2.8	4.8	3.1	16	0.00022	49	60
1LA9 063-2KA□□	2.5	4.9	2.5	16	0.00026	49	60
1LA9 070-2KA□□	3.3	6.5	3.1	16	0.00041	52	63
1LA9 073-2KA□□	3.6	6.3	2.9	16	0.0005	52	63
1LA9 080-2KA□□	4.4	8.3	3.2	16	0.001	56	67
1LA9 083-2KA□□	3.8	7	3.2	16	0.0013	56	67
1LA9 090-2KA□□	4.1	7	3.5	16	0.0018	60	72
1LA9 096-2KA□□	4.1	7	3.5	16	0.0022	60	72
1LA9 106-2KA□□	3.4	7	3.2	16	0.0044	62	74
1LA9 113-2KA□□	2.8	7	3.2	16	0.0077	63	75
1LA9 130-2KA□□	2.7	7	3.2	16	0.019	68	80
1LA9 131-2KA□□	2.8	7	3.1	16	0.024	68	80
1LA9 163-2KA□□	2.5	7	3.1	16	0.044	70	82
1LA9 164-2KA□□	2.5	7	3.1	16	0.051	70	82
1LA9 166-2KA□□	2.4	7	3.1	16	0.065	70	82
1LA9 183-2WA□□	2.6	7.2	3.3	16	0.09	70	83
1LA9 206-2WA□□	2.5	7	3.2	16	0.16	71	84
1LA9 207-2WA□□	2.7	7	3.3	16	0.2	71	84

The motors can also be used for 60 Hz according to EPACT, see Pages 2/28 to 2/33.

# IEC Squirrel-Cage Motors

## Standard motors up to frame size 315 L

Self-ventilated energy-saving motors with high efficiency – Aluminum series 1LA9

### Selection and ordering data (continued)

Rated output at 50 Hz	Frame size	Operating values at rated output							Order No.	Price	Weight IM B3 type of construction approx. m kg
		Rated speed at 50 Hz	Rated torque at 50 Hz	Efficiency Class according to CEMEP	Efficiency at 50 Hz 4/4-load	Efficiency at 50 Hz 3/4-load	Power factor at 50 Hz 4/4-load	Rated current at 400 V, 50 Hz			
$P_{\text{rated}}$ kW	FS	$n_{\text{rated}}$ rpm	$T_{\text{rated}}$ Nm		$\eta_{\text{rated}}$ %	$\eta_{\text{rated}}$ %	$\cos\phi_{\text{rated}}$	$I_{\text{rated}}$ A	For Order No. supplements for voltage and type of construction, see table below		
<b>4-pole, 1500 rpm at 50 Hz, temperature class 155 (F), IP55 degree of protection, for use according to CEMEP</b>											
0.06	56 M	1380	0.42		61	61	0.66	0.22	<b>1LA9 050-4KAQQ</b>	3	
0.09	56 M	1390	0.62		62	62	0.68	0.31	<b>1LA9 053-4KAQQ</b>	3.8	
0.12	63 M	1395	0.82		66	66	0.65	0.41	<b>1LA9 060-4KAQQ</b>	4.1	
0.18	63 M	1395	1.3		65	65	0.68	0.59	<b>1LA9 063-4KAQQ</b>	5.1	
0.25	71 M	1410	1.7		70	70	0.64	0.81	<b>1LA9 070-4KAQQ</b>	6	
0.37	71 M	1385	2.6		71	71	0.73	1.04	<b>1LA9 073-4KAQQ</b>	7.2	
0.55	80 M	1410	3.7		77	77	0.78	1.32	<b>1LA9 080-4KAQQ</b>	9.8	
0.75	80 M	1400	5.1		81	81	0.75	1.78	<b>1LA9 083-4KAQQ</b>	12.3	
1.1	90 S	1440	7.3	EFF1	84	84	0.77	2.45	<b>1LA9 090-4KAQQ</b>	15	
1.5	90 L	1440	9.9	EFF1	85	85	0.77	3.3	<b>1LA9 096-4KAQQ</b>	18	
2.2	100 L	1435	15	EFF1	86.5	86.5	0.82	4.5	<b>1LA9 106-4KAQQ</b>	25	
3	100 L	1435	20	EFF1	87.5	87.7	0.81	6.1	<b>1LA9 107-4KAQQ</b>	30	
4	112 M	1440	27	EFF1	88.5	89	0.81	8.1	<b>1LA9 113-4KAQQ</b>	37	
5.5	132 S	1455	36	EFF1	89.5	89.5	0.84	10.6	<b>1LA9 130-4KAQQ</b>	45	
7.5	132 M	1455	49	EFF1	90.3	90.5	0.84	14.2	<b>1LA9 133-4KAQQ</b>	60	
11	160 M	1460	72	EFF1	91.5	92	0.85	20.5	<b>1LA9 163-4KAQQ</b>	81	
15	160 L	1460	98	EFF1	92	92.3	0.86	27.5	<b>1LA9 166-4KAQQ</b>	107	
18.5	180 M	1465	121	EFF1	92.5	93	0.84	34.5 <sup>1)</sup>	<b>1LA9 183-4WAQQ</b>	126	
22	180 L	1465	143	EFF1	93	93.4	0.84	40.5 <sup>1)</sup>	<b>1LA9 186-4WAQQ</b>	146	
30	200 L	1465	196	EFF1	93.5	94	0.87	53	<b>1LA9 207-4WAQQ</b>	199	

### Order No. supplements

Motor type	Penultimate position: Voltage code 50 Hz				Final position: Type of construction code							
	230 VΔ/400 VY	400 VΔ/690 VY	500 VY	500 VΔ	Without flange	With flange			With standard flange		With special flange	
					IM B3/6/7/8, IM V6, IM V5 without protective cover	IM B5, IM V1 without protective cover	IM V1 with protective cover <sup>2)</sup>	IM B35	IM B14, IM V19, IM V18 without protective cover	IM B34	IM B14, IM V19, IM V18 without protective cover	
	1	6	3	5	0	1	4	6	2	7	3	
<b>1LA9 05</b> . . . . . □□	○	○	○	–	□	✓	–	–	✓	✓	✓	
<b>1LA9 06</b> . . . . . □□	○	○	○	–	□	✓	✓	✓	✓	✓	✓	
<b>1LA9 07</b> . . . . . □□	○	○	○	–	□	✓	✓	✓	✓	✓	✓	
<b>1LA9 08</b> . . . . . □□	○	○	○	–	□	✓	✓	✓	✓	✓	✓	
<b>1LA9 09</b> . . . . . □□	○	○	○	–	□	✓	✓	✓	✓	✓	✓	
<b>1LA9 10</b> . . . . . □□	○	○	○	○	□	✓	✓	✓	✓	✓	✓	
<b>1LA9 11</b> . . . . . □□	○	○	○	○	□	✓	✓	✓	✓	✓	✓	
<b>1LA9 13</b> . . . . . □□	○	○	○	○	□	✓	✓	✓	✓	✓	✓	
<b>1LA9 16</b> . . . . . □□	○	○	○	○	□	✓	✓	✓	✓	✓	✓	
<b>1LA9 18</b> . . . . . □□	○	○	○	○	□	✓ <sup>3)</sup>	✓	✓	–	–	–	
<b>1LA9 20</b> . . . . . □□	○	○	○	○	□	✓ <sup>3)</sup>	✓	✓	–	–	–	

- Standard version
- Without additional charge
- ✓ With additional charge
- Not possible

Order other voltages with voltage code **9** in the penultimate position and the corresponding order code (see "Special versions" in the "Selection and ordering data" under "Voltages").

Order other types of construction with type of construction code **9** in the final position and the corresponding order code (see "Special versions" in the "Selection and ordering data" under "Types of construction").

<sup>1)</sup> For connection to 230 V, parallel supply cables are necessary (see catalog part 0 "Introduction", "Connection, circuit and connection box").

<sup>2)</sup> The "Second shaft extension" option, order code **K16** is not possible.

<sup>3)</sup> Type of construction IM V3 is only possible using type of construction code **9** and order code **M1G**.

# IEC Squirrel-Cage Motors

## Standard motors up to frame size 315 L

Self-ventilated energy-saving motors with high efficiency – Aluminum series 1LA9

### Selection and ordering data (continued)

Order No.	Locked-rotor torque with direct starting torque	Locked-rotor current as multiple of rated current	Breakdown torque torque	Torque class	Moment of inertia	Noise at rated output	
	$T_{LR}/T_{rated}$	$I_{LR}/I_{rated}$	$T_B/T_{rated}$	CL	$J$ kgm <sup>2</sup>	Measuring surface sound pressure level at 50 Hz $L_{p(A)}$ dB(A)	Sound pressure level at 50 Hz $L_{WA}$ dB(A)
<b>4-pole, 1500 rpm at 50 Hz, temperature class 155 (F), IP55 degree of protection, for use according to CEMEP</b>							
1LA9 050-4KA□□	2.7	3.1	2.8	16	0.00027	42	53
1LA9 053-4KA□□	2.8	3.2	2.8	16	0.00035	42	53
1LA9 060-4KA□□	2.7	3.5	2.6	16	0.00037	42	53
1LA9 063-4KA□□	3	3.6	2.5	16	0.00045	42	53
1LA9 070-4KA□□	3.6	4.3	3.1	16	0.00076	44	55
1LA9 073-4KA□□	3.3	4.2	3	16	0.00095	44	55
1LA9 080-4KA□□	3.4	5.6	2.9	16	0.0017	47	58
1LA9 083-4KA□□	4	5.8	3.5	16	0.0024	47	58
1LA9 090-4KA□□	3.1	6.4	3.2	16	0.0033	48	60
1LA9 096-4KA□□	3.6	6.7	3.4	16	0.004	48	60
1LA9 106-4KA□□	3.4	7	3.6	16	0.0062	53	65
1LA9 107-4KA□□	3.8	7	3.9	16	0.0077	53	65
1LA9 113-4KA□□	3.2	6.9	3.2	16	0.014	53	65
1LA9 130-4KA□□	3.2	7	3.6	16	0.023	62	74
1LA9 133-4KA□□	3.4	7	3.6	16	0.029	62	74
1LA9 163-4KA□□	2.6	6.9	3.2	16	0.055	66	78
1LA9 166-4KA□□	2.8	7	3.3	16	0.072	66	78
1LA9 183-4WA□□	2.8	7	3.2	16	0.15	63	76
1LA9 186-4WA□□	3.1	7.3	3.4	16	0.19	63	76
1LA9 207-4WA□□	3	7	3.2	16	0.32	65	78

The motors can also be used for 60 Hz according to EPACT, see Pages 2/28 to 2/33.

# IEC Squirrel-Cage Motors

## Standard motors up to frame size 315 L

Self-ventilated energy-saving motors with high efficiency – Aluminum series 1LA9

### Selection and ordering data (continued)

Rated output at 50 Hz	Frame size	Operating values at rated output						Rated current at 400 V, 50 Hz	Order No.	Price	Weight IM B3 type of construction approx. m kg
		Rated speed at 50 Hz	Rated torque at 50 Hz	Efficiency Class according to CEMEP	Efficiency at 50 Hz 4/4-load	Efficiency at 50 Hz 3/4-load	Power factor at 50 Hz 4/4-load				
$P_{\text{rated}}$ kW	FS	$n_{\text{rated}}$ rpm	$T_{\text{rated}}$ Nm	$\eta_{\text{rated}}$ %	$\eta_{\text{rated}}$ %	$\cos\phi_{\text{rated}}$	$I_{\text{rated}}$ A	For Order No. supplements for voltage and type of construction, see table below			
<b>6-pole, 1000 rpm at 50 Hz, temperature class 155 (F), IP55 degree of protection, for use according to CEMEP</b>											
0.75	90 S	925	7.7	75.5	75.5	0.72	2	<b>1LA9 090-6KAQQ</b>		15.7	
1.1	90 L	940	11	82	82	0.7	2.75	<b>1LA9 096-6KAQQ</b>		19	
1.5	100 L	935	15	85	85	0.73	3.6	<b>1LA9 106-6KAQQ</b>		25	
2.2	112 M	955	22	84	84	0.7	5.4	<b>1LA9 113-6KAQQ</b>		37	
4	132 M	950	40	84	84	0.81	8.5	<b>1LA9 133-6KAQQ</b>		49	
5.5	132 M	960	55	86	86	0.77	12	<b>1LA9 134-6KAQQ</b>		64	
7.5	160 M	965	74	88	88	0.72	17	<b>1LA9 163-6KAQQ</b>		98	
11	160 L	960	109	88.5	88.5	0.78	23	<b>1LA9 166-6KAQQ</b>		105	
15	180 L	970	148	91	91	0.75	31.5	<b>1LA9 186-6WAQQ</b>		144	
18.5	200 L	975	181	91	91	0.77	38	<b>1LA9 206-6WAQQ</b>		186	
22	200 L	975	215	91.5	91.5	0.77	45	<b>1LA9 207-6WAQQ</b>		217	

### Order No. supplements

Motor type	Penultimate position: Voltage code				Final position: Type of construction code						
	50 Hz				Without flange	With flange			With standard flange		With special flange
	230 VΔ/400 VY	400 VΔ/690 VY	500 VY	500 VΔ	IM B3/6/7/8, IM V6, IM V5 without protective cover	IM B5, IM V1 without protective cover	IM V1 with protective cover <sup>1)</sup>	IM B35	IM B14, IM V19, IM V18 without protective cover	IM B34	IM B14, IM V19, IM V18 without protective cover
1	6	3	5	0	1	4	6	2	7	3	
<b>1LA9 05</b> . . . . . □□	○	○	○	–	□	✓	–	–	✓	✓	✓
<b>1LA9 06</b> . . . . . □□	○	○	○	–	□	✓	✓	✓	✓	✓	✓
<b>1LA9 07</b> . . . . . □□	○	○	○	–	□	✓	✓	✓	✓	✓	✓
<b>1LA9 08</b> . . . . . □□	○	○	○	–	□	✓	✓	✓	✓	✓	✓
<b>1LA9 09</b> . . . . . □□	○	○	○	–	□	✓	✓	✓	✓	✓	✓
<b>1LA9 10</b> . . . . . □□	○	○	○	○	□	✓	✓	✓	✓	✓	✓
<b>1LA9 11</b> . . . . . □□	○	○	○	○	□	✓	✓	✓	✓	✓	✓
<b>1LA9 13</b> . . . . . □□	○	○	○	○	□	✓	✓	✓	✓	✓	✓
<b>1LA9 16</b> . . . . . □□	○	○	○	○	□	✓	✓	✓	✓	✓	✓
<b>1LA9 18</b> . . . . . □□	○	○	○	○	□	✓ <sup>2)</sup>	✓	✓	–	–	–
<b>1LA9 20</b> . . . . . □□	○	○	○	○	□	✓ <sup>2)</sup>	✓	✓	–	–	–

- Standard version
- Without additional charge
- ✓ With additional charge
- Not possible

Order other voltages with voltage code **9** in the penultimate position and the corresponding order code (see “Special versions” in the “Selection and ordering data” under “Voltages”).

Order other types of construction with type of construction code **9** in the final position and the corresponding order code (see “Special versions” in the “Selection and ordering data” under “Types of construction”).

<sup>1)</sup> The “Second shaft extension” option, order code **K16** is not possible.

<sup>2)</sup> Type of construction IM V3 is only possible using type of construction code **9** and order code **M1G**.

# IEC Squirrel-Cage Motors

## Standard motors up to frame size 315 L

Self-ventilated energy-saving motors with high efficiency – Aluminum series 1LA9

### Selection and ordering data (continued)

Order No.	Locked-rotor torque with direct starting torque	Locked-rotor current as multiple of rated current	Breakdown torque torque	Torque class	Moment of inertia	Noise at rated output	
	$T_{LR}/T_{rated}$	$I_{LR}/I_{rated}$	$T_B/T_{rated}$	CL	$J$ kgm <sup>2</sup>	Measuring surface sound pressure level at 50 Hz $L_{pFA}$ dB(A)	Sound pressure level at 50 Hz $L_{WA}$ dB(A)
<b>6-pole, 1000 rpm at 50 Hz, temperature class 155 (F), IP55 degree of protection, for use according to CEMEP</b>							
<b>1LA9 090-6KA□□</b>	3	4.4	2.5	16	0.0033	43	55
<b>1LA9 096-6KA□□</b>	3.7	5.7	3.2	16	0.005	43	55
<b>1LA9 106-6KA□□</b>	3.5	6.2	3.4	16	0.0065	47	59
<b>1LA9 113-6KA□□</b>	2.9	6.2	3	16	0.014	52	64
<b>1LA9 133-6KA□□</b>	3	6.3	2.7	16	0.025	63	75
<b>1LA9 134-6KA□□</b>	3.7	7.3	3.6	16	0.03	63	75
<b>1LA9 163-6KA□□</b>	2.4	5.5	2.5	16	0.063	66	78
<b>1LA9 166-6KA□□</b>	3.1	6.9	3.2	16	0.072	66	78
<b>1LA9 186-6WA□□</b>	2.2	6.5	2.5	16	0.19	66	78
<b>1LA9 206-6WA□□</b>	2.8	6.2	2.5	16	0.28	66	78
<b>1LA9 207-6WA□□</b>	2.8	6.2	2.5	16	0.36	66	78

The motors can also be used for 60 Hz according to EPACT, see Pages 2/28 to 2/33.

# IEC Squirrel-Cage Motors

## Standard motors up to frame size 315 L

Self-ventilated energy-saving motors with high efficiency – Aluminum series 1LA9

### Selection and ordering data (continued)

Rated output at 60 Hz	Frame size	Operating values at rated output					Power factor at 60 Hz 4/4-load	Rated current at 460 V, 60 Hz	Order No.	Price	Weight IM B3 type of construction approx. m kg
		Rated speed at 60 Hz	Rated torque at 60 Hz	EPACT with CC No. CC 032A	Nominal efficiency at 60 Hz						
$P_{\text{rated}}$ HP	FS	$n_{\text{rated}}$ rpm	$T_{\text{rated}}$ Nm		$\eta_{\text{rated}}$ %	$\cos\phi_{\text{rated}}$	$I_{\text{rated}}$ A	For Order No. supplements for voltage and type of construction, see table below			
<b>2-pole, 3600 rpm at 60 Hz, temperature class 155 (F), IP55 degree of protection, for use in the North American market according to EPACT</b>											
0.12	56 M	3440	0.25	No	70	0.74	0.23	<b>1LA9 050-2KA00</b>		3	
0.16	56 M	3440	0.33	No	71	0.76	0.28	<b>1LA9 053-2KA00</b>		3.8	
0.25	63 M	3440	0.53	No	71	0.79	0.4	<b>1LA9 060-2KA00</b>		4.1	
0.33	63 M	3460	0.69	No	72	0.76	0.56	<b>1LA9 063-2KA00</b>		5.1	
0.5	71 M	3445	1	No	72	0.75	0.86	<b>1LA9 070-2KA00</b>		6	
0.75	71 M	3445	1.6	No	73	0.73	1.3	<b>1LA9 073-2KA00</b>		7.2	
1	80 M	3485	2	Yes	75.5	0.82	1.52	<b>1LA9 080-2KA00</b>		9.8	
1.5	80 M	3480	3.1	Yes	82.5	0.88	1.9	<b>1LA9 083-2KA00</b>		12.3	
2	90 S	3510	4.1	Yes	84	0.86	2.6	<b>1LA9 090-2KA00</b>		15	
3	90 L	3510	6.1	Yes	85.5	0.85	3.8	<b>1LA9 096-2KA00</b>		18.6	
4	100 L	3510	8.1	No	86.5	0.87	5	<b>1LA9 106-2KA00</b>		24	
5	112 M	3540	10	Yes	87.5	0.88	6	<b>1LA9 113-2KA00</b>		35	
7.5	132 S	3540	15	Yes	88.5	0.9	8.7	<b>1LA9 130-2KA00</b>		43	
10	132 S	3540	20	Yes	89.5	0.92	11.4	<b>1LA9 131-2KA00</b>		56	
15	160 M	3555	30	Yes	90.2	0.9	17	<b>1LA9 163-2KA00</b>		73	
20	160 M	3555	40	Yes	90.2	0.9	23.2	<b>1LA9 164-2KA00</b>		82	
25	160 L	3550	50	Yes	91	0.92	27.7	<b>1LA9 166-2KA00</b>		102	
30	180 M	3545	60	Yes	91	0.86	36	<b>1LA9 183-2WA00</b>		131	
40	200 L	3555	80	Yes	91.7	0.88	46.5	<b>1LA9 206-2WA00</b>		185	
50	200 L	3555	100	Yes	92.4	0.88	57	<b>1LA9 207-2WA00</b>		214	

### Order No. supplements

Motor type	Penultimate position: Voltage code		Final position: Type of construction code						
	60 Hz		Without flange		With flange		With standard flange		With special flange
	460 VY	460 VΔ	IM B3/6/7/8, IM V6, IM V5 without protective cover	IM B5, IM V1 without protective cover IM V3	IM V1 with protective cover <sup>1)</sup>	IM B35	IM B14, IM V19, IM V18 without protective cover	IM B34	
1	6	0	1	4	6	2	7	3	
<b>1LA9 05 . . . . 00</b>	<input type="radio"/>	<input type="radio"/>	<input type="checkbox"/>	<input checked="" type="checkbox"/>	-	-	<input checked="" type="checkbox"/>	<input checked="" type="checkbox"/>	<input checked="" type="checkbox"/>
<b>1LA9 06 . . . . 00</b>	<input type="radio"/>	<input type="radio"/>	<input type="checkbox"/>	<input checked="" type="checkbox"/>	<input checked="" type="checkbox"/>	<input checked="" type="checkbox"/>	<input checked="" type="checkbox"/>	<input checked="" type="checkbox"/>	<input checked="" type="checkbox"/>
<b>1LA9 07 . . . . 00</b>	<input type="radio"/>	<input type="radio"/>	<input type="checkbox"/>	<input checked="" type="checkbox"/>	<input checked="" type="checkbox"/>	<input checked="" type="checkbox"/>	<input checked="" type="checkbox"/>	<input checked="" type="checkbox"/>	<input checked="" type="checkbox"/>
<b>1LA9 08 . . . . 00</b>	<input type="radio"/>	<input type="radio"/>	<input type="checkbox"/>	<input checked="" type="checkbox"/>	<input checked="" type="checkbox"/>	<input checked="" type="checkbox"/>	<input checked="" type="checkbox"/>	<input checked="" type="checkbox"/>	<input checked="" type="checkbox"/>
<b>1LA9 09 . . . . 00</b>	<input type="radio"/>	<input type="radio"/>	<input type="checkbox"/>	<input checked="" type="checkbox"/>	<input checked="" type="checkbox"/>	<input checked="" type="checkbox"/>	<input checked="" type="checkbox"/>	<input checked="" type="checkbox"/>	<input checked="" type="checkbox"/>
<b>1LA9 10 . . . . 00</b>	<input type="radio"/>	<input type="radio"/>	<input type="checkbox"/>	<input checked="" type="checkbox"/>	<input checked="" type="checkbox"/>	<input checked="" type="checkbox"/>	<input checked="" type="checkbox"/>	<input checked="" type="checkbox"/>	<input checked="" type="checkbox"/>
<b>1LA9 11 . . . . 00</b>	<input type="radio"/>	<input type="radio"/>	<input type="checkbox"/>	<input checked="" type="checkbox"/>	<input checked="" type="checkbox"/>	<input checked="" type="checkbox"/>	<input checked="" type="checkbox"/>	<input checked="" type="checkbox"/>	<input checked="" type="checkbox"/>
<b>1LA9 13 . . . . 00</b>	<input type="radio"/>	<input type="radio"/>	<input type="checkbox"/>	<input checked="" type="checkbox"/>	<input checked="" type="checkbox"/>	<input checked="" type="checkbox"/>	<input checked="" type="checkbox"/>	<input checked="" type="checkbox"/>	<input checked="" type="checkbox"/>
<b>1LA9 16 . . . . 00</b>	<input type="radio"/>	<input type="radio"/>	<input type="checkbox"/>	<input checked="" type="checkbox"/>	<input checked="" type="checkbox"/>	<input checked="" type="checkbox"/>	<input checked="" type="checkbox"/>	<input checked="" type="checkbox"/>	<input checked="" type="checkbox"/>
<b>1LA9 18 . . . . 00</b>	<input type="radio"/>	<input type="radio"/>	<input type="checkbox"/>	<input checked="" type="checkbox"/> <sup>2)</sup>	<input checked="" type="checkbox"/>	<input checked="" type="checkbox"/>	-	-	-
<b>1LA9 20 . . . . 00</b>	<input type="radio"/>	<input type="radio"/>	<input type="checkbox"/>	<input checked="" type="checkbox"/> <sup>2)</sup>	<input checked="" type="checkbox"/>	<input checked="" type="checkbox"/>	-	-	-

- Standard version
- Without additional charge
- With additional charge
- Not possible

Order other voltages with voltage code **9** in the penultimate position and the corresponding order code (see "Special versions" in the "Selection and ordering data" under "Voltages").

Order other types of construction with type of construction code **9** in the final position and the corresponding order code (see "Special versions" in the "Selection and ordering data" under "Types of construction").

<sup>1)</sup> The "Second shaft extension" option, order code **K16** is not possible.

<sup>2)</sup> Type of construction IM V3 is only possible using type of construction code **9** and order code **M1G**.

# IEC Squirrel-Cage Motors

## Standard motors up to frame size 315 L

Self-ventilated energy-saving motors with high efficiency – Aluminum series 1LA9

### Selection and ordering data (continued)

Order No.	Locked-rotor torque with direct starting torque	Locked-rotor current as multiple of rated current	Breakdown torque	Torque class	Moment of inertia	Noise at rated output	
	$T_{LR}/T_{rated}$	$I_{LR}/I_{rated}$	$T_B/T_{rated}$	CL	$J$ kgm <sup>2</sup>	Measuring surface sound pressure level at 60 Hz $L_{pFA}$ dB(A)	Sound pressure level at 60 Hz $L_{WA}$ dB(A)
<b>2-pole, 3600 rpm at 60 Hz, temperature class 155 (F), IP55 degree of protection, for use in the North American market according to EPACT</b>							
1LA9 050-2KA□□	3.6	5.5	3.8	16	0.00015	45	56
1LA9 053-2KA□□	3.2	5.4	3.4	16	0.0002	45	56
1LA9 060-2KA□□	2.8	4.9	3.3	16	0.00022	53	64
1LA9 063-2KA□□	2.5	5	2.7	16	0.00026	53	64
1LA9 070-2KA□□	3.3	7.5	3.4	16	0.00041	56	67
1LA9 073-2KA□□	3.4	7.2	3.7	16	0.0005	56	67
1LA9 080-2KA□□	4.4	9.6	4.4	16	0.001	60	71
1LA9 083-2KA□□	3.8	8.6	3.2	16	0.0013	60	71
1LA9 090-2KA□□	4.1	8.6	4.1	16	0.0018	64	76
1LA9 096-2KA□□	4.1	8.5	5.1	16	0.0022	64	76
1LA9 106-2KA□□	3.4	8.6	3.7	16	0.0044	66	78
1LA9 113-2KA□□	2.8	9.2	4	16	0.0077	67	79
1LA9 130-2KA□□	2.7	8.5	3.8	16	0.019	72	84
1LA9 131-2KA□□	2.8	8.3	3.7	16	0.024	72	84
1LA9 163-2KA□□	2.5	8.5	3.7	16	0.044	74	86
1LA9 164-2KA□□	2.5	8.5	3.7	16	0.051	74	86
1LA9 166-2KA□□	2.4	8.5	3.5	16	0.065	74	86
1LA9 183-2WA□□	2.6	8.6	3.5	16	0.09	74	87
1LA9 206-2WA□□	2.5	8.4	3.6	16	0.16	75	88
1LA9 207-2WA□□	2.7	8.4	3.7	16	0.2	75	88

The motors can also be used for 50 Hz according to CEMEP, see Pages 2/22 to 2/27.

# IEC Squirrel-Cage Motors

## Standard motors up to frame size 315 L

Self-ventilated energy-saving motors with high efficiency – Aluminum series 1LA9

### Selection and ordering data (continued)

Rated output at 60 Hz	Frame size	Operating values at rated output				Nominal efficiency at 60 Hz	Power factor at 60 Hz 4/4-load	Rated current at 460 V, 60 Hz	Order No. For Order No. supplements for voltage and type of construction, see table below	Price	Weight IM B3 type of construction approx. m kg
$P_{\text{rated}}$ HP	FS	$n_{\text{rated}}$ rpm	$T_{\text{rated}}$ Nm	EPACT with CC No. CC 032A	$\cos\phi_{\text{rated}}$						
<b>4-pole, 1800 rpm at 60 Hz, temperature class 155 (F), IP55 degree of protection, for use in the North American market according to EPACT</b>											
0.08	56 M	1715	0.33	No	63	0.65	0.18	<b>1LA9 050-4KA□□</b>		3	
0.12	56 M	1725	0.5	No	64	0.6	0.29	<b>1LA9 053-4KA□□</b>		3.8	
0.16	63 M	1710	0.66	No	68	0.6	0.37	<b>1LA9 060-4KA□□</b>		4.1	
0.25	63 M	1705	1.1	No	66	0.63	0.54	<b>1LA9 063-4KA□□</b>		5.1	
0.33	71 M	1730	1.4	No	69	0.6	0.76	<b>1LA9 070-4KA□□</b>		6	
0.5	71 M	1725	2.1	No	70	0.68	0.98	<b>1LA9 073-4KA□□</b>		7.2	
0.75	80 M	1725	3.1	No	75.5	0.74	1.24	<b>1LA9 080-4KA□□</b>		9.8	
1	80 M	1720	4.1	Yes	82.5	0.75	1.59	<b>1LA9 083-4KA□□</b>		12.3	
1.5	90 S	1755	6.1	Yes	84	0.76	2.15	<b>1LA9 090-4KA□□</b>		15	
2	90 L	1755	8.1	Yes	84	0.76	2.95	<b>1LA9 096-4KA□□</b>		18	
3	100 L	1750	12	No	87.5	0.79	4	<b>1LA9 106-4KA□□</b>		25	
4	100 L	1750	16	No	87.5	0.79	5.5	<b>1LA9 107-4KA□□</b>		30	
5	112 M	1755	20	Yes	87.5	0.79	6.7	<b>1LA9 113-4KA□□</b>		37	
7.5	132 S	1760	30	Yes	89.5	0.81	9.5	<b>1LA9 130-4KA□□</b>		45	
10	132 M	1760	40	Yes	89.5	0.82	12.8	<b>1LA9 133-4KA□□</b>		60	
15	160 M	1765	61	Yes	91	0.85	17.9	<b>1LA9 163-4KA□□</b>		81	
20	160 L	1765	81	Yes	91	0.85	24.5	<b>1LA9 166-4KA□□</b>		107	
25	180 M	1770	101	Yes	92.4	0.83	30.5	<b>1LA9 183-4WA□□</b>		126	
30	180 L	1770	121	Yes	92.4	0.83	36	<b>1LA9 186-4WA□□</b>		146	
40	200 L	1770	161	Yes	93	0.86	47	<b>1LA9 207-4WA□□</b>		199	

### Order No. supplements

Motor type	Penultimate position: Voltage code		Final position: Type of construction code						
	60 Hz	460 VΔ	Without flange	With flange		With standard flange		With special flange	
	460 VY	460 VΔ	IM B3/6/7/8, IM V6, IM V5 without protective cover	IM B5, IM V1 without protective cover	IM V1 with protective cover <sup>1)</sup>	IM B35	IM B14, IM V19, IM V18 without protective cover	IM B34	IM B14, IM V19, IM V18 without protective cover
	<b>1</b>	<b>6</b>	<b>0</b>	<b>1</b>	<b>4</b>	<b>6</b>	<b>2</b>	<b>7</b>	<b>3</b>
<b>1LA9 05</b> . . . . □□	○	○	□	✓	–	–	✓	✓	✓
<b>1LA9 06</b> . . . . □□	○	○	□	✓	✓	✓	✓	✓	✓
<b>1LA9 07</b> . . . . □□	○	○	□	✓	✓	✓	✓	✓	✓
<b>1LA9 08</b> . . . . □□	○	○	□	✓	✓	✓	✓	✓	✓
<b>1LA9 09</b> . . . . □□	○	○	□	✓	✓	✓	✓	✓	✓
<b>1LA9 10</b> . . . . □□	○	○	□	✓	✓	✓	✓	✓	✓
<b>1LA9 11</b> . . . . □□	○	○	□	✓	✓	✓	✓	✓	✓
<b>1LA9 13</b> . . . . □□	○	○	□	✓	✓	✓	✓	✓	✓
<b>1LA9 16</b> . . . . □□	○	○	□	✓	✓	✓	✓	✓	✓
<b>1LA9 18</b> . . . . □□	○	○	□	✓ <sup>2)</sup>	✓	✓	–	–	–
<b>1LA9 20</b> . . . . □□	○	○	□	✓ <sup>2)</sup>	✓	✓	–	–	–

- Standard version
- Without additional charge
- ✓ With additional charge
- Not possible

Order other voltages with voltage code **9** in the penultimate position and the corresponding order code (see "Special versions" in the "Selection and ordering data" under "Voltages").

Order other types of construction with type of construction code **9** in the final position and the corresponding order code (see "Special versions" in the "Selection and ordering data" under "Types of construction").

<sup>1)</sup> The "Second shaft extension" option, order code **K16** is not possible.

<sup>2)</sup> Type of construction IM V3 is only possible using type of construction code **9** and order code **M1G**.



# IEC Squirrel-Cage Motors

## Standard motors up to frame size 315 L

Self-ventilated energy-saving motors with high efficiency – Aluminum series 1LA9

### Selection and ordering data (continued)

Order No.	Locked-rotor torque with direct starting torque	Locked-rotor current as multiple of rated current	Breakdown torque torque	Torque class	Moment of inertia	Noise at rated output	
	$T_{LR}/T_{rated}$	$I_{LR}/I_{rated}$	$T_B/T_{rated}$	CL	$J$ kgm <sup>2</sup>	Measuring surface sound pressure level at 60 Hz $L_{pFA}$ dB(A)	Sound pressure level at 60 Hz $L_{WA}$ dB(A)
<b>4-pole, 1800 rpm at 60 Hz, temperature class 155 (F), IP55 degree of protection, for use in the North American market according to EPACT</b>							
1LA9 050-4KA□□	2.7	3.4	3	16	0.00027	46	57
1LA9 053-4KA□□	2.8	3.5	3	16	0.00035	46	57
1LA9 060-4KA□□	2.7	3.9	2.8	16	0.00037	46	57
1LA9 063-4KA□□	3	3.6	3.1	16	0.00045	46	57
1LA9 070-4KA□□	3.6	4.9	3.4	16	0.00076	48	59
1LA9 073-4KA□□	3.3	4.9	3.4	16	0.00095	48	59
1LA9 080-4KA□□	3.4	6.8	3.6	16	0.0017	51	62
1LA9 083-4KA□□	4	7.3	3.9	16	0.0024	51	62
1LA9 090-4KA□□	3.1	7.7	3.9	16	0.0033	52	64
1LA9 096-4KA□□	3.6	8.1	4.2	16	0.004	52	64
1LA9 106-4KA□□	3.4	8.4	4.3	16	0.0062	57	69
1LA9 107-4KA□□	3.8	8.7	4.6	16	0.0077	57	69
1LA9 113-4KA□□	3.2	8.6	3.9	16	0.014	57	69
1LA9 130-4KA□□	3.2	8.7	4.1	16	0.023	66	78
1LA9 133-4KA□□	3.4	8.7	4.1	16	0.029	66	78
1LA9 163-4KA□□	2.6	8.1	3.2	16	0.055	70	82
1LA9 166-4KA□□	2.8	8.5	3.5	16	0.072	70	82
1LA9 183-4WA□□	2.8	8.4	3.6	16	0.15	67	80
1LA9 186-4WA□□	3.1	8.8	3.9	16	0.19	67	80
1LA9 207-4WA□□	3	8.3	3.6	16	0.32	69	82

The motors can also be used for 50 Hz according to CEMEP, see Pages 2/22 to 2/27.

# IEC Squirrel-Cage Motors

## Standard motors up to frame size 315 L

Self-ventilated energy-saving motors with high efficiency – Aluminum series 1LA9

### Selection and ordering data (continued)

Rated output at 60 Hz	Frame size	Operating values at rated output					Power factor at 60 Hz 4/4-load	Rated current at 460 V, 60 Hz	Order No. For Order No. supplements for voltage and type of construction, see table below	Price	Weight IM B3 type of construction approx. <i>m</i> kg
		Rated speed at 60 Hz	Rated torque at 60 Hz	EPACT with CC No. CC 032A	Nominal efficiency at 60 Hz						
$P_{\text{rated}}$ <b>HP</b>	FS	$n_{\text{rated}}$ rpm	$T_{\text{rated}}$ Nm		$\eta_{\text{rated}}$ %	$\cos\phi_{\text{rated}}$	$I_{\text{rated}}$ A				
<b>6-pole, 1200 rpm at 60 Hz, temperature class 155 (F), IP55 degree of protection, for use in the North American market according to EPACT</b>											
1	90 S	1140	6.2	Yes	80	0.66	1.78	<b>1LA9 090-6KA□□</b>		15.7	
1.5	90 L	1150	9.3	Yes	85.5	0.64	2.55	<b>1LA9 096-6KA□□</b>		19	
2	100 L	1150	12	No	86.5	0.70	3.1	<b>1LA9 106-6KA□□</b>		25	
3	112 M	1160	18	Yes	87.5	0.66	4.8	<b>1LA9 113-6KA□□</b>		37	
5	132 M	1160	31	Yes	87.5	0.77	6.9	<b>1LA9 133-6KA□□</b>		49	
7.5	132 M	1160	46	Yes	89.5	0.73	10.6	<b>1LA9 134-6KA□□</b>		64	
10	160 M	1165	61	Yes	89.5	0.7	15	<b>1LA9 163-6KA□□</b>		98	
15	160 L	1165	92	Yes	90.2	0.77	19	<b>1LA9 166-6KA□□</b>		105	
20	180 L	1175	121	Yes	90.2	0.75	28	<b>1LA9 186-6WA□□</b>		144	
25	200 L	1175	152	Yes	91.7	0.75	34	<b>1LA9 206-6WA□□</b>		186	
30	200 L	1175	182	Yes	91.7	0.75	40	<b>1LA9 207-6WA□□</b>		217	

### Order No. supplements

Motor type	Penultimate position: Voltage code		Final position: Type of construction code						
	60 Hz	460 VΔ	Without flange	With flange		IM B35	With standard flange		With special flange
	460 VY	460 VΔ	IM B3/6/7/8, IM V6, IM V5 without protective cover	IM B5, IM V1 without protective cover	IM V1 with protective cover <sup>1)</sup>	IM V3	IM B14, IM V19, IM V18 without protective cover	IM B34	IM B14, IM V19, IM V18 without protective cover
	1	6	0	1	4	6	2	7	3
<b>1LA9 05</b> . . . . □□	○	○	□	✓	–	–	✓	✓	✓
<b>1LA9 06</b> . . . . □□	○	○	□	✓	✓	✓	✓	✓	✓
<b>1LA9 07</b> . . . . □□	○	○	□	✓	✓	✓	✓	✓	✓
<b>1LA9 08</b> . . . . □□	○	○	□	✓	✓	✓	✓	✓	✓
<b>1LA9 09</b> . . . . □□	○	○	□	✓	✓	✓	✓	✓	✓
<b>1LA9 10</b> . . . . □□	○	○	□	✓	✓	✓	✓	✓	✓
<b>1LA9 11</b> . . . . □□	○	○	□	✓	✓	✓	✓	✓	✓
<b>1LA9 13</b> . . . . □□	○	○	□	✓	✓	✓	✓	✓	✓
<b>1LA9 16</b> . . . . □□	○	○	□	✓	✓	✓	✓	✓	✓
<b>1LA9 18</b> . . . . □□	○	○	□	✓ <sup>2)</sup>	✓	✓	–	–	–
<b>1LA9 20</b> . . . . □□	○	○	□	✓ <sup>2)</sup>	✓	✓	–	–	–

- Standard version
- Without additional charge
- ✓ With additional charge
- Not possible

Order other voltages with voltage code **9** in the penultimate position and the corresponding order code (see "Special versions" in the "Selection and ordering data" under "Voltages").

Order other types of construction with type of construction code **9** in the final position and the corresponding order code (see "Special versions" in the "Selection and ordering data" under "Types of construction").

<sup>1)</sup> The "Second shaft extension" option, order code **K16** is not possible.

<sup>2)</sup> Type of construction IM V3 is only possible using type of construction code **9** and order code **M1G**.

# IEC Squirrel-Cage Motors

## Standard motors up to frame size 315 L

Self-ventilated energy-saving motors with high efficiency – Aluminum series 1LA9

### Selection and ordering data (continued)

Order No.	Locked-rotor torque with direct starting torque	Locked-rotor current as multiple of rated current	Breakdown torque torque	Torque class	Moment of inertia	Noise at rated output	
	$T_{LR}/T_{rated}$	$I_{LR}/I_{rated}$	$T_B/T_{rated}$	CL	$J$ kgm <sup>2</sup>	Measuring surface sound pressure level at 60 Hz $L_{pFA}$ dB(A)	Sound pressure level at 60 Hz $L_{WA}$ dB(A)
<b>6-pole, 1200 rpm at 60 Hz, temperature class 155 (F), IP55 degree of protection, for use in the North American market according to EPACT</b>							
<b>1LA9 090-6KA□□</b>	3	5.6	3	16	0.0033	47	59
<b>1LA9 096-6KA□□</b>	3.7	6.4	3.7	16	0.005	47	59
<b>1LA9 106-6KA□□</b>	3.5	7.2	3.8	16	0.0065	51	63
<b>1LA9 113-6KA□□</b>	2.9	7.5	3.7	16	0.014	56	68
<b>1LA9 133-6KA□□</b>	3	7.9	3.6	16	0.025	67	79
<b>1LA9 134-6KA□□</b>	3.7	8.4	4.3	16	0.03	67	79
<b>1LA9 163-6KA□□</b>	2.4	6.4	2.8	16	0.063	70	82
<b>1LA9 166-6KA□□</b>	3.1	8.3	3.8	16	0.072	70	82
<b>1LA9 186-6WA□□</b>	2.8	7.1	2.8	16	0.19	70	82
<b>1LA9 206-6WA□□</b>	2.8	7.1	2.8	16	0.28	70	82
<b>1LA9 207-6WA□□</b>	2.8	7.2	2.8	16	0.36	70	82

The motors can also be used for 50 Hz according to CEMEP, see Pages 2/22 to 2/27.

# IEC Squirrel-Cage Motors

## Standard motors up to frame size 315 L

Self-ventilated motors with increased output –  
Aluminum series 1LA9

### Selection and ordering data

Rated output at		Frame size	Operating values at rated output						Power factor at 50 Hz 4/4-load	Rated current at 400 V, 50 Hz	Order No.	Price	Weight IM B3 type of construction approx. m kg
50 Hz	60 Hz		Rated speed at 50 Hz	Rated torque at 50 Hz	Efficiency at 50 Hz 4/4-load	Efficiency at 50 Hz 3/4-load	Efficiency at 50 Hz 4/4-load	Efficiency at 50 Hz 3/4-load					
$P_{rated}$ kW	$P_{rated}$ kW	FS	$n_{rated}$ rpm	$T_{rated}$ Nm	$\eta_{rated}$ %	$\eta_{rated}$ %	$\eta_{rated}$ %	$\cos\phi_{rated}$	$I_{rated}$ A	For Order No. supplements for voltage and type of construction, see table below			
<b>2-pole, 3000 rpm at 50 Hz, 3600 rpm at 60 Hz, temperature class 155 (F), IP55 degree of protection, with increased output, used as temperature class 155 (F)</b>													
0.2	0.23	56 M	2830	0.67	69	69	69	0.82	0.51	<b>1LA9 053-2LAQQ</b>		3.8	
0.33	0.38	63 M	2775	1.1	68	67.5	67.5	0.8	0.88	<b>1LA9 060-2LAQQ</b>		4.1	
0.45	0.52	63 M	2720	1.6	68	67.5	67.5	0.84	1.14	<b>1LA9 063-2LAQQ</b>		5.1	
0.65	0.75	71 M	2720	2.3	72	72	72	0.83	1.56	<b>1LA9 070-2LAQQ</b>		6	
0.94	1.08	71 M	2735	3.3	73	73	73	0.82	2.25	<b>1LA9 073-2LAQQ</b>		7.2	
1.45	1.67	80 M	2820	4.9	76	76	76	0.83	3.3	<b>1LA9 080-2LAQQ</b>		9.8	
1.75	2.01	80 M	2840	5.9	77	77.5	77.5	0.82	4	<b>1LA9 083-2LAQQ</b>		12.3	
2.9	3.34	90 S	2825	9.8	81	81	81	0.82	6.3	<b>1LA9 090-2LAQQ</b>		15	
3.8	4.37	90 L	2810	13	81	81	81	0.85	8	<b>1LA9 096-2LAQQ</b>		18.6	
4.4	5.06	100 L	2880	15	82	82	82	0.83	9.3	<b>1LA9 106-2LAQQ</b>		24	
6.5	7.48	112 M	2900	21	85	85	85	0.83	13.2	<b>1LA9 113-2LAQQ</b>		35	
9	10.35	132 S	2895	29	87	87	87	0.9	16.6	<b>1LA9 130-2LAQQ</b>		43	
12	13.8	132 S	2905	39	87	87	87	0.89	22.5	<b>1LA9 131-2LAQQ</b>		56	
18	20.7	160 M	2910	59	89	89	89	0.87	33.5	<b>1LA9 163-2LAQQ</b>		73	
21	24.15	160 M	2910	68	90	90	90	0.91	37	<b>1LA9 164-2LAQQ</b>		82	
26	29.9	160 L	2920	85	91	91	91	0.91	45.5	<b>1LA9 166-2LAQQ</b>		102	
33	37.95	180 M	2940	107	92	92	92	0.86	60	<b>1LA9 183-2AAQQ</b>		131	
44	50.6	200 L	2945	143	92	92	92	0.86	80	<b>1LA9 206-2AAQQ</b>		182	
53	60.95	200 L	2945	172	92.5	92.5	92.5	0.87	95	<b>1LA9 207-2AAQQ</b>		211	

### Order No. supplements

Motor type	Penultimate position: Voltage code						Final position: Type of construction code							
	50 Hz			60 Hz			Without flange		With flange			With standard flange		With special flange
	230 VΔ/400 VY	400 VΔ/690 VY	500 VY	500 VΔ	460 VY	460 VΔ	IM B3/6/7/8, IM V6, IM V5 without protective cover	IM B5, IM V1 without protective cover IM V3	IM V1 with protective cover <sup>1)</sup>	IM B35	IM B14, IM V19, IM V18 without protective cover	IM B34	IM B14, IM V19, IM V18 without protective cover	
1	6	3	5	1	6	0	1	4	6	2	7	3		
<b>1LA9 05 . . . . □□</b>	○	○	○	–	○	○	□	✓	–	–	✓	✓	✓	
<b>1LA9 06 . . . . □□</b>	○	○	○	–	○	○	□	✓	✓	✓	✓	✓	✓	
<b>1LA9 07 . . . . □□</b>	○	○	○	–	○	○	□	✓	✓	✓	✓	✓	✓	
<b>1LA9 08 . . . . □□</b>	○	○	○	–	○	○	□	✓	✓	✓	✓	✓	✓	
<b>1LA9 09 . . . . □□</b>	○	○	○	–	○	○	□	✓	✓	✓	✓	✓	✓	
<b>1LA9 10 . . . . □□</b>	○	○	○	○	○	○	□	✓	✓	✓	✓	✓	✓	
<b>1LA9 11 . . . . □□</b>	○	○	○	○	○	○	□	✓	✓	✓	✓	✓	✓	
<b>1LA9 13 . . . . □□</b>	○	○	○	○	○	○	□	✓	✓	✓	✓	✓	✓	
<b>1LA9 16 . . . . □□</b>	○	○	○	○	○	○	□	✓	✓	✓	✓	✓	✓	
<b>1LA9 18 . . . . □□</b>	○	○	○	○	○	○	□	✓ <sup>2)</sup>	✓	✓	–	–	–	
<b>1LA9 20 . . . . □□</b>	○	○	○	○	○	○	□	✓ <sup>2)</sup>	✓	✓	–	–	–	

- Standard version
- Without additional charge
- ✓ With additional charge
- Not possible

Order other voltages with voltage code **9** in the penultimate position and the corresponding order code (see “Special versions” in the “Selection and ordering data” under “Voltages”).

Order other types of construction with type of construction code **9** in the final position and the corresponding order code (see “Special versions” in the “Selection and ordering data” under “Types of construction”).

<sup>1)</sup> The “Second shaft extension” option, order code **K16** is not possible.

<sup>2)</sup> Type of construction IM V3 is only possible using type of construction code **9** and order code **M1G**.

# IEC Squirrel-Cage Motors

## Standard motors up to frame size 315 L

Self-ventilated motors with increased output –  
Aluminum series 1LA9

### Selection and ordering data (continued)

Order No.	Locked-rotor torque with direct starting torque	Locked-rotor current as multiple of rated current	Breakdown torque torque	Torque class	Moment of inertia	Noise at rated output	
	$T_{LR}/T_{rated}$	$I_{LR}/I_{rated}$	$T_B/T_{rated}$	CL	$J$ kgm <sup>2</sup>	Measuring surface sound pressure level at 50 Hz $L_{pFA}$ dB(A)	Sound pressure level at 50 Hz $L_{WA}$ dB(A)
<b>2-pole, 3000 rpm at 50 Hz, 3600 rpm at 60 Hz, temperature class 155 (F), IP55 degree of protection, with increased output, used as temperature class 155 (F)</b>							
<b>1LA9 053-2LA□□</b>	2.1	4.5	2.3	16	0.0002	41	52
<b>1LA9 060-2LA□□</b>	2.3	4.4	2.2	16	0.00022	49	60
<b>1LA9 063-2LA□□</b>	2.2	4.2	2.3	16	0.00026	49	60
<b>1LA9 070-2LA□□</b>	2.4	4.5	2.5	16	0.00041	52	63
<b>1LA9 073-2LA□□</b>	2.5	4.8	2.4	16	0.0005	52	63
<b>1LA9 080-2LA□□</b>	3.1	6.7	3.1	16	0.001	56	67
<b>1LA9 083-2LA□□</b>	3.7	7.4	3.5	16	0.0013	56	67
<b>1LA9 090-2LA□□</b>	3.2	6.5	3	16	0.0018	60	72
<b>1LA9 096-2LA□□</b>	3.1	6.5	2.7	16	0.0022	60	72
<b>1LA9 106-2LA□□</b>	3	7.8	3.2	16	0.0044	62	74
<b>1LA9 113-2LA□□</b>	3	8.6	3.8	16	0.0077	63	75
<b>1LA9 130-2LA□□</b>	2	6.4	2.6	16	0.019	68	80
<b>1LA9 131-2LA□□</b>	3	7.4	3.2	16	0.024	68	80
<b>1LA9 163-2LA□□</b>	2.2	7	3.1	16	0.044	70	82
<b>1LA9 164-2LA□□</b>	2	6.9	2.7	16	0.051	70	82
<b>1LA9 166-2LA□□</b>	2.2	7.7	3.2	16	0.065	70	82
<b>1LA9 183-2AA□□</b>	2.5	7.4	3.3	16	0.09	70	83
<b>1LA9 206-2AA□□</b>	2.4	7.8	3.2	16	0.16	71	84
<b>1LA9 207-2AA□□</b>	2.6	8.2	3.3	16	0.2	71	84

# IEC Squirrel-Cage Motors

## Standard motors up to frame size 315 L

Self-ventilated motors with increased output –  
Aluminum series 1LA9

### Selection and ordering data (continued)

Rated output at		Frame size	Operating values at rated output						Power factor at 50 Hz 4/4-load	Rated current at 400 V, 50 Hz	Order No. For Order No. supplements for voltage and type of construction, see table below	Price	Weight IM B3 type of construction approx. <i>m</i> kg
50 Hz	60 Hz		Rated speed at 50 Hz	Rated torque at 50 Hz	Efficiency at 50 Hz 4/4-load	Efficiency at 50 Hz 3/4-load	$\cos\phi$ rated	$I$ rated					
$P_{rated}$ kW	$P_{rated}$ kW	FS	$n_{rated}$ rpm	$T_{rated}$ Nm	$\eta_{rated}$ %	$\eta_{rated}$ %	$\cos\phi$ rated	$I$ rated A					
<b>4-pole, 1500 rpm at 50 Hz, 1800 rpm at 60 Hz, temperature class 155 (F), IP55 degree of protection, with increased output, used as temperature class 155 (F)</b>													
0.14	0.16	56 M	1385	0.97	62	60.5	0.74	0.44	<b>1LA9 053-4LAQQ</b>		3.8		
0.21	0.24	63 M	1335	1.5	60	58.5	0.77	0.66	<b>1LA9 060-4LAQQ</b>		4.1		
0.29	0.33	63 M	1330	2.1	60	58.5	0.71	0.98	<b>1LA9 063-4LAQQ</b>		5.1		
0.45	0.52	71 M	1340	3.2	64	63	0.71	1.42	<b>1LA9 070-4LAQQ</b>		6		
0.6	0.69	71 M	1340	4.3	70	70	0.75	1.64	<b>1LA9 073-4LAQQ</b>		7.2		
0.9	1.04	80 M	1340	6.4	70	70	0.81	2.3	<b>1LA9 080-4LAQQ</b>		9.8		
1.25	1.44	80 M	1340	8.9	70	70	0.83	3.1	<b>1LA9 083-4LAQQ</b>		12.3		
1.8	2.07	90 S	1380	12	77	77.5	0.83	4.05	<b>1LA9 090-4LAQQ</b>		15		
2.5	2.88	90 L	1390	17	76	76	0.81	5.9	<b>1LA9 096-4LAQQ</b>		18		
4	4.6	100 L	1410	27	77	77.5	0.81	9.3	<b>1LA9 107-4LAQQ</b>		25		
5.5	6.33	112 M	1440	36	82	82	0.8	12.2	<b>1LA9 113-4LAQQ</b>		37		
8.6	9.89	132 S	1440	57	84	84	0.83	17.8	<b>1LA9 130-4LAQQ</b>		45		
11	12.65	132 M	1450	72	86	86	0.82	22.5	<b>1LA9 133-4LAQQ</b>		60		
17	19.55	160 M	1455	112	88	88	0.84	33	<b>1LA9 163-4LAQQ</b>		81		
22	25.3	160 L	1455	144	88	88	0.82	44	<b>1LA9 166-4LAQQ</b>		107		
26	30	180 M	1460	170	90.5	90.5	0.83	50	<b>1LA9 183-4AAQQ</b>		126		
32	38	180 L	1465	209	91.3	91.3	0.84	60	<b>1LA9 186-4AAQQ</b>		146		
43	49.6	200 L	1465	280	91.7	91.7	0.85	80	<b>1LA9 207-4AAQQ</b>		196		

### Order No. supplements

Motor type	Penultimate position: Voltage code				Final position: Type of construction code									
	50 Hz				60 Hz				Without flange		With flange		With standard flange	
	230 VΔ/400 VY	400 VΔ/690 VY	500 VY	500 VΔ	460 VY	460 VΔ	IM B3/6/7/8, IM V6, IM V5 without protective cover	IM B5, IM V1 without protective cover 1)	IM V1 with protective cover 1)	IM B35	IM B14, IM V19, IM V18 without protective cover	IM B34	IM B14, IM V19, IM V18 without protective cover	
	<b>1</b>	<b>6</b>	<b>3</b>	<b>5</b>	<b>1</b>	<b>6</b>	<b>0</b>	<b>1</b>	<b>4</b>	<b>6</b>	<b>2</b>	<b>7</b>	<b>3</b>	
<b>1LA9 05</b> . . . . □□	○	○	○	–	○	○	□	✓	–	–	✓	✓	✓	
<b>1LA9 06</b> . . . . □□	○	○	○	–	○	○	□	✓	✓	✓	✓	✓	✓	
<b>1LA9 07</b> . . . . □□	○	○	○	–	○	○	□	✓	✓	✓	✓	✓	✓	
<b>1LA9 08</b> . . . . □□	○	○	○	–	○	○	□	✓	✓	✓	✓	✓	✓	
<b>1LA9 09</b> . . . . □□	○	○	○	–	○	○	□	✓	✓	✓	✓	✓	✓	
<b>1LA9 10</b> . . . . □□	○	○	○	○	○	○	□	✓	✓	✓	✓	✓	✓	
<b>1LA9 11</b> . . . . □□	○	○	○	○	○	○	□	✓	✓	✓	✓	✓	✓	
<b>1LA9 13</b> . . . . □□	○	○	○	○	○	○	□	✓	✓	✓	✓	✓	✓	
<b>1LA9 16</b> . . . . □□	○	○	○	○	○	○	□	✓	✓	✓	✓	✓	✓	
<b>1LA9 18</b> . . . . □□	○	○	○	○	○	○	□	✓ <sup>2)</sup>	✓	✓	–	–	–	
<b>1LA9 20</b> . . . . □□	○	○	○	○	○	○	□	✓ <sup>2)</sup>	✓	✓	–	–	–	

- Standard version
- Without additional charge
- ✓ With additional charge
- Not possible

Order other voltages with voltage code **9** in the penultimate position and the corresponding order code (see "Special versions" in the "Selection and ordering data" under "Voltages").

Order other types of construction with type of construction code **9** in the final position and the corresponding order code (see "Special versions" in the "Selection and ordering data" under "Types of construction").

<sup>1)</sup> The "Second shaft extension" option, order code **K16** is not possible.

<sup>2)</sup> Type of construction IM V3 is only possible using type of construction code **9** and order code **M1G**.

# IEC Squirrel-Cage Motors

## Standard motors up to frame size 315 L

Self-ventilated motors with increased output –  
Aluminum series 1LA9

### Selection and ordering data (continued)

Order No.	Locked-rotor torque with direct starting torque	Locked-rotor current as multiple of rated current	Breakdown torque torque	Torque class	Moment of inertia	Noise at rated output	
	$T_{LR}/T_{rated}$	$I_{LR}/I_{rated}$	$T_B/T_{rated}$	CL	$J$ kgm <sup>2</sup>	Measuring surface sound pressure level at 50 Hz $L_{p(A)}$ dB(A)	Sound pressure level at 50 Hz $L_{WA}$ dB(A)
<b>4-pole, 1500 rpm at 50 Hz, 1800 rpm at 60 Hz, temperature class 155 (F), IP55 degree of protection, with increased output, used as temperature class 155 (F)</b>							
1LA9 053-4LA□□	2.3	3.5	2.2	16	0.00035	42	53
1LA9 060-4LA□□	2.1	2.9	2.1	16	0.00037	42	53
1LA9 063-4LA□□	2.3	2.9	2.3	16	0.00045	42	53
1LA9 070-4LA□□	2.3	3.4	2.3	16	0.00076	44	55
1LA9 073-4LA□□	2.3	3.6	2.3	16	0.00095	44	55
1LA9 080-4LA□□	2.3	4.1	2.4	16	0.0017	47	58
1LA9 083-4LA□□	2.7	4.5	2.4	16	0.0024	47	58
1LA9 090-4LA□□	2.4	5.1	2.4	16	0.0033	48	60
1LA9 096-4LA□□	2.5	5.1	2.3	16	0.004	48	60
1LA9 107-4LA□□	2.7	6	3	16	0.0062	53	65
1LA9 113-4LA□□	3	6.8	3	16	0.014	53	65
1LA9 130-4LA□□	2.3	6.8	2.7	16	0.023	62	74
1LA9 133-4LA□□	2.8	7.4	3.1	16	0.029	62	74
1LA9 163-4LA□□	2.9	7.5	2.8	16	0.055	66	78
1LA9 166-4LA□□	3.1	8.3	3.4	16	0.072	66	78
1LA9 183-4AA□□	2.4	7.5	3.2	16	0.15	63	76
1LA9 186-4AA□□	2.5	7.9	3.4	16	0.19	63	76
1LA9 207-4AA□□	2.7	7.8	3.5	16	0.32	65	78

# IEC Squirrel-Cage Motors

## Standard motors up to frame size 315 L

Self-ventilated energy-saving motors with improved efficiency – Cast-iron series 1LA6/1LG4

### Selection and ordering data

Rated output at		Frame size	Operating values at rated output							Order No.	Price	Weight IM B3 type of construction approx. m kg
50 Hz	60 Hz		Rated speed at 50 Hz	Rated torque at 50 Hz	Efficiency Class according to CEMEP	Efficiency at 50 Hz 4/4-load	Efficiency at 50 Hz 3/4-load	Power factor at 50 Hz 4/4-load	Rated current at 400 V, 50 Hz			
$P_{rated}$ kW	$P_{rated}$ kW	FS	$n_{rated}$ rpm	$T_{rated}$ Nm		$\eta_{rated}$ %	$\eta_{rated}$ %	$\cos\phi_{rated}$	$I_{rated}$ A	For Order No. supplements for voltage and type of construction, see table below		
<b>2-pole, 3000 rpm at 50 Hz, 3600 rpm at 60 Hz, temperature class 155 (F), IP55 degree of protection</b>												
3	3.45	100 L	2890	9.9	EFF2	84	84	0.85	6.1	<b>1LA6 106-2AA□□</b>	34	
4	4.6	112 M	2905	13	EFF2	86	86	0.86	7.8	<b>1LA6 113-2AA□□</b>	43	
5.5	6.3	132 S	2925	18	EFF2	86.5	86.5	0.89	10.4	<b>1LA6 130-2AA□□</b>	53	
7.5	8.6	132 S	2930	24	EFF2	88	88	0.89	13.8	<b>1LA6 131-2AA□□</b>	58	
11	12.6	160 M	2940	36	EFF2	89.5	89.5	0.88	20	<b>1LA6 163-2AA□□</b>	96	
15	17.3	160 M	2940	49	EFF2	90	90.2	0.9	26.5	<b>1LA6 164-2AA□□</b>	105	
18.5	21.3	160 L	2940	60	EFF2	91	91.2	0.91	32	<b>1LA6 166-2AA□□</b>	115	
22	24.5	180 M	2945	71	EFF 2	91.6	91.6	0.86	40.5 <sup>1)</sup>	<b>1LG4 183-2AA□□</b>	145	
30	33.5	200 L	2950	97	EFF 2	91.8	91.9	0.88	54 <sup>1)</sup>	<b>1LG4 206-2AA□□</b>	205	
37	41.5	200 L	2955	120	EFF 2	92.9	93.2	0.89	65 <sup>1)</sup>	<b>1LG4 207-2AA□□</b>	225	
45	51	225 M	2960	145	EFF 2	93.6	93.9	0.88	79 <sup>1)</sup>	<b>1LG4 223-2AA□□</b>	285	
55	62	250 M	2970	177	EFF 2	93.6	93.8	0.88	96	<b>1LG4 253-2AB□□</b>	375	
75	84	280 S	2975	241	EFF 2	94.5	94.3	0.88	130 <sup>1)</sup>	<b>1LG4 280-2AB□□</b>	500	
90	101	280 M	2975	289	EFF 2	95.1	95.2	0.89	154 <sup>1)</sup>	<b>1LG4 283-2AB□□</b>	540	
110	123	315 S	2982	352		94.6	93.8	0.88	190 <sup>1)</sup>	<b>1LG4 310-2AB□□</b>	720	
132	148	315 M	2982	423		95.1	94.8	0.9	225 <sup>1)</sup>	<b>1LG4 313-2AB□□</b>	775	
160	180	315 L	2982	512		95.5	95.3	0.91	265 <sup>2)</sup>	<b>1LG4 316-2AB□□</b>	900	
200	224	315 L	2982	641		95.9	95.8	0.92	325 <sup>2)</sup>	<b>1LG4 317-2AB□□</b>	1015	

### Order No. supplements

Motor type	Penultimate position: Voltage code						Final position: Type of construction code							
	50 Hz			60 Hz			Without flange		With flange			With standard flange		With special flange
	230 VΔ/400 VY	400 VΔ/690 VY	500 VY	500 VΔ	460 VY	460 VΔ	IM B3/6/7/8, IM V6, IM V5 without protective cover <sup>3)</sup>	IM B5, IM V1 without protective cover IM V3 <sup>4)</sup>	IM V1 without protective cover <sup>4)</sup>	IM V1 with protective cover <sup>4)5)</sup>	IM B35	IM B14, IM V19, IM V18 without protective cover	IM B34	IM B14, IM V19, IM V18 without protective cover
	<b>1</b>	<b>6</b>	<b>3</b>	<b>5</b>	<b>1</b>	<b>6</b>	<b>0</b>	<b>1</b>	<b>8</b>	<b>4</b>	<b>6</b>	<b>2</b>	<b>7</b>	<b>3</b>
<b>1LA6 10</b> . . . . □□	○	○	○	○	○	○	□	✓	–	✓	✓	✓	✓	✓
<b>1LA6 11</b> . . . . □□	○	○	○	○	○	○	□	✓	–	✓	✓	✓	✓	✓
<b>1LA6 13</b> . . . . □□	○	○	○	○	○	○	□	✓	–	✓	✓	✓	✓	✓
<b>1LA6 16</b> . . . . □□	○	○	○	○	○	○	□	✓	–	✓	✓	✓	✓	✓
<b>1LG4 18</b> . . . . □□	○	○	○	○	○	○	□	✓ <sup>6)</sup>	–	✓	✓	–	–	–
<b>1LG4 20</b> . . . . □□	○	○	○	○	○	○	□	✓ <sup>6)</sup>	–	✓	✓	–	–	–
<b>1LG4 22</b> . . . . □□	○	○	○	○	○	○	□	✓ <sup>6)</sup>	–	✓	✓	–	–	–
<b>1LG4 25</b> . . . . □□	○	○	○	○	○	○	□	✓ <sup>6)</sup>	–	✓	✓	–	–	–
<b>1LG4 28</b> . . . . □□	○	○	○	○	○	○	□	✓ <sup>6)</sup>	–	✓	✓	–	–	–
<b>1LG4 310</b> . . . . □□	○	○	○	○	○	○	□	✓ <sup>6)</sup>	–	✓	✓	–	–	–
<b>1LG4 313</b> . . . . □□	○	○	○	○	○	○	□	✓ <sup>6)</sup>	–	✓	✓	–	–	–
<b>1LG4 316</b> . . . . □□	–	○	–	○	–	○	□ <sup>7)</sup>	–	✓ <sup>8)</sup>	✓ <sup>8)</sup>	✓	–	–	–
<b>1LG4 317</b> . . . . □□	–	○	–	○	–	○	□ <sup>7)</sup>	–	✓ <sup>8)</sup>	✓ <sup>8)</sup>	✓	–	–	–

- Standard version
- Without additional charge
- ✓ With additional charge
- Not possible

Order other voltages with voltage code **9** in the penultimate position and the corresponding order code (see “Special versions” in the “Selection and ordering data” under “Voltages”).

Order other types of construction with type of construction code **9** in the final position and the corresponding order code (see “Special versions” in the “Selection and ordering data” under “Types of construction”).

For footnotes, see Page 2/39 bottom.



# IEC Squirrel-Cage Motors

## Standard motors up to frame size 315 L

Self-ventilated energy-saving motors with improved efficiency – Cast-iron series 1LA6/1LG4

### Selection and ordering data (continued)

Order No.	Locked-rotor torque with direct starting torque	Locked-rotor current as multiple of rated current	Breakdown torque	Torque class	Moment of inertia	Noise at rated output	
	$T_{LR}/T_{rated}$	$I_{LR}/I_{rated}$	$T_B/T_{rated}$	CL	$J$ kgm <sup>2</sup>	Measuring surface sound pressure level at 50 Hz $L_{pFA}$ dB(A)	Sound pressure level at 50 Hz $L_{WA}$ dB(A)
<b>2-pole, 3000 rpm at 50 Hz, 3600 rpm at 60 Hz, temperature class 155 (F), IP55 degree of protection</b>							
<b>1LA6 106-2AA□□</b>	2.8	6.8	3	16	0.0035	62	74
<b>1LA6 113-2AA□□</b>	2.6	7.2	2.9	16	0.0059	63	75
<b>1LA6 130-2AA□□</b>	2	5.9	2.8	16	0.015	68	80
<b>1LA6 131-2AA□□</b>	2.3	6.9	3	16	0.019	68	80
<b>1LA6 163-2AA□□</b>	2.1	6.5	2.9	16	0.034	70	82
<b>1LA6 164-2AA□□</b>	2.2	6.6	3	16	0.043	70	82
<b>1LA6 166-2AA□□</b>	2.4	7	3.1	16	0.051	70	82
<b>1LG4 183-2AA□□</b>	2.5	6.4	3.4	16	0.068	67	80
<b>1LG4 206-2AA□□</b>	2.3	6.5	3	16	0.13	73	86
<b>1LG4 207-2AA□□</b>	2.5	7.2	3.3	16	0.15	73	86
<b>1LG4 223-2AA□□</b>	2.4	6.7	3.1	16	0.22	73	86
<b>1LG4 253-2AB□□</b>	2.1	6.7	3.1	13	0.4	75	88
<b>1LG4 280-2AB□□</b>	2.5	7.5	3.1	13	0.72	74	87
<b>1LG4 283-2AB□□</b>	2.6	7.2	3.1	13	0.83	74	87
<b>1LG4 310-2AB□□</b>	2.4	7.2	3.1	13	1.2	80	94
<b>1LG4 313-2AB□□</b>	2.4	6.9	3	13	1.4	80	94
<b>1LG4 316-2AB□□</b>	2.4	7	3	13	1.6	80	94
<b>1LG4 317-2AB□□</b>	2.3	6.7	2.9	13	2.1	80	94

- 1) For connection to 230 V, parallel supply cables are necessary (see catalog part 0 "Introduction", "Connection, circuit and connection box").
- 2) For connection to 400 V, parallel supply cables are necessary (see catalog part 0 "Introduction", "Connection, circuit and connection box").
- 3) If motors 1LG4 183-... to 1LG4 318-... (motor series 1LG4 frame sizes 180 M to 315 L) in types of construction with feet IM B6, IM B7, IM V6 or IM V5 without protective cover are fixed to the wall, it is recommended that the motor feet are supported.
- 4) 1LG4 220-... to 1LG4 318-... motors (motor series 1LG4 frame sizes 225 S to 315 L) are supplied with two screw-in eyebolts in accordance with IM B5, whereby one can be rotated in accordance with IM V1 or IM V3. It is important to note that stress must not be applied perpendicular to the ring plane.
- 5) The "Second shaft extension" option, order code **K16** is not possible.
- 6) Type of construction IM V3 is only possible using type of construction code **9** and order code **M1G**.
- 7) Type of construction IM V6 and IM V5 without protective cover is only possible using type of construction code **9** and order code **M1E** or **M1D**.
- 8) 2-pole motors in 60 Hz version available on request.

# IEC Squirrel-Cage Motors

## Standard motors up to frame size 315 L

Self-ventilated energy-saving motors with improved efficiency – Cast-iron series 1LA6/1LG4

### Selection and ordering data (continued)

Rated output at		Frame size	Operating values at rated output							Order No.	Price	Weight IM B3 type of construction approx. m kg
50 Hz	60 Hz		Rated speed at 50 Hz	Rated torque at 50 Hz	Efficiency Class according to CEMEP	Efficiency at 50 Hz 4/4-load	Efficiency at 50 Hz 3/4-load	Power factor at 50 Hz 4/4-load	Rated current at 400 V, 50 Hz			
$P_{rated}$ kW	$P_{rated}$ kW	FS	$n_{rated}$ rpm	$T_{rated}$ Nm	EFF2	$\eta_{rated}$ %	$\eta_{rated}$ %	$\cos\phi_{rated}$	$I_{rated}$ A	For Order No. supplements for voltage and type of construction, see table below		
<b>4-pole, 1500 rpm at 50 Hz, 1800 rpm at 60 Hz, temperature class 155 (F), IP55 degree of protection</b>												
2.2	2.55	100 L	1420	15	EFF2	82	82.5	0.82	4.7	1LA6 106-4AA□□	33	
3	3.45	100 L	1420	20	EFF2	83	83.5	0.82	6.4	1LA6 107-4AA□□	36	
4	4.6	112 M	1440	27	EFF2	85	85.5	0.83	8.2	1LA6 113-4AA□□	45	
5.5	6.3	132 S	1455	36	EFF2	86	86	0.81	11.4	1LA6 130-4AA□□	55	
7.5	8.6	132 M	1455	49	EFF2	87	87.5	0.82	15.2	1LA6 133-4AA□□	62	
11	12.6	160 M	1460	72	EFF2	88.5	89	0.84	21.5	1LA6 163-4AA□□	100	
15	17.3	160 L	1460	98	EFF2	90	90.2	0.84	28.5	1LA6 166-4AA□□	114	
18.5	21.3	180 M	1465	121	EFF 2	90.4	90.8	0.84	35 <sup>1)</sup>	1LG4 183-4AA□□	140	
22	25.3	180 L	1465	143	EFF 2	91	91.5	0.84	41.5 <sup>1)</sup>	1LG4 186-4AA□□	155	
30	34.5	200 L	1465	196	EFF 2	91.6	92	0.85	56 <sup>1)</sup>	1LG4 207-4AA□□	205	
37	42.5	225 S	1475	240	EFF 2	92.2	92.6	0.85	68 <sup>1)</sup>	1LG4 220-4AA□□	265	
45	52	225 M	1475	291	EFF 2	93.1	93.6	0.86	81 <sup>1)</sup>	1LG4 223-4AA□□	300	
55	63	250 M	1480	355	EFF 2	93.5	93.8	0.85	100	1LG4 253-4AA□□	390	
75	86	280 S	1485	482	EFF 2	94.2	94.1	0.85	136 <sup>1)</sup>	1LG4 280-4AA□□	535	
90	104	280 M	1485	579	EFF 2	94.6	94.6	0.86	160 <sup>1)</sup>	1LG4 283-4AA□□	580	
110	127	315 S	1488	706	EFF 2	94.6	94.6	0.85	198 <sup>1)</sup>	1LG4 310-4AA□□	730	
132	152	315 M	1488	847	EFF 2	95.2	95.2	0.85	235 <sup>1)</sup>	1LG4 313-4AA□□	810	
160	184	315 L	1486	1028	EFF 2	95.7	95.8	0.86	280 <sup>2)</sup>	1LG4 316-4AA□□	955	
200	230	315 L	1486	1285	EFF 2	95.9	96.2	0.88	340 <sup>2)</sup>	1LG4 317-4AA□□	1060	

### Order No. supplements

Motor type	Penultimate position: Voltage code						Final position: Type of construction code							
	50 Hz			60 Hz			Without flange	With flange		With standard flange			With special flange	
	230 VΔ/400 VY	400 VΔ/690 VY	500 VY	500 VΔ	460 VY	460 VΔ	IM B3/6/7/8, IM V6, IM V5 without protective cover 3)	IM B5, IM V1 without protective cover 4)	IM V1 without protective cover 4)	IM V1 with protective cover 4)5)	IM B35	IM B14, IM V19, IM V18 without protective cover	IM B34	IM B14, IM V19, IM V18 without protective cover
	<b>1</b>	<b>6</b>	<b>3</b>	<b>5</b>	<b>1</b>	<b>6</b>	<b>0</b>	<b>1</b>	<b>8</b>	<b>4</b>	<b>6</b>	<b>2</b>	<b>7</b>	<b>3</b>
1LA6 10 - ... □□	○	○	○	○	○	○	□	✓	-	✓	✓	✓	✓	✓
1LA6 11 - ... □□	○	○	○	○	○	○	□	✓	-	✓	✓	✓	✓	✓
1LA6 13 - ... □□	○	○	○	○	○	○	□	✓	-	✓	✓	✓	✓	✓
1LA6 16 - ... □□	○	○	○	○	○	○	□	✓	-	✓	✓	✓	✓	✓
1LG4 18 - ... □□	○	○	○	○	○	○	□	✓ <sup>6)</sup>	-	✓	✓	-	-	-
1LG4 20 - ... □□	○	○	○	○	○	○	□	✓ <sup>6)</sup>	-	✓	✓	-	-	-
1LG4 22 - ... □□	○	○	○	○	○	○	□	✓ <sup>6)</sup>	-	✓	✓	-	-	-
1LG4 25 - ... □□	○	○	○	○	○	○	□	✓ <sup>6)</sup>	-	✓	✓	-	-	-
1LG4 28 - ... □□	○	○	○	○	○	○	□	✓ <sup>6)</sup>	-	✓	✓	-	-	-
1LG4 310 - ... □□	○	○	○	○	○	○	□	✓ <sup>6)</sup>	-	✓	✓	-	-	-
1LG4 313 - ... □□	○	○	○	○	○	○	□	✓ <sup>6)</sup>	-	✓	✓	-	-	-
1LG4 316 - ... □□	-	○	-	○	-	○	□ <sup>7)</sup>	-	✓	✓	✓	-	-	-
1LG4 317 - ... □□	-	○	-	○	-	○	□ <sup>7)</sup>	-	✓	✓	✓	-	-	-

- Standard version
- Without additional charge
- ✓ With additional charge
- Not possible

Order other voltages with voltage code **9** in the penultimate position and the corresponding order code (see "Special versions" in the "Selection and ordering data" under "Voltages").

Order other types of construction with type of construction code **9** in the final position and the corresponding order code (see "Special versions" in the "Selection and ordering data" under "Types of construction").

For footnotes, see Page 2/41 bottom.

# IEC Squirrel-Cage Motors

## Standard motors up to frame size 315 L

Self-ventilated energy-saving motors with improved efficiency – Cast-iron series 1LA6/1LG4

### Selection and ordering data (continued)

Order No.	Locked-rotor torque	Locked-rotor current	Breakdown torque	Torque class	Moment of inertia	Noise at rated output	
	with direct starting torque	as multiple of rated current	torque	CL	J	Measuring surface sound pressure level at 50 Hz	Sound pressure level at 50 Hz
	$T_{LR}/T_{rated}$	$I_{LR}/I_{rated}$	$T_B/T_{rated}$		kgm <sup>2</sup>	$L_{pA}$ dB(A)	$L_{WA}$ dB(A)
<b>4-pole, 1500 rpm at 50 Hz, 1800 rpm at 60 Hz, temperature class 155 (F), IP55 degree of protection</b>							
<b>1LA6 106-4AA□□</b>	2.5	5.6	2.8	16	0.0047	53	65
<b>1LA6 107-4AA□□</b>	2.7	5.6	3	16	0.0055	53	65
<b>1LA6 113-4AA□□</b>	2.7	6	3	16	0.012	53	65
<b>1LA6 130-4AA□□</b>	2.5	6.3	3.1	16	0.018	62	74
<b>1LA6 133-4AA□□</b>	2.7	6.7	3.2	16	0.023	62	74
<b>1LA6 163-4AA□□</b>	2.2	6.2	2.7	16	0.043	66	78
<b>1LA6 166-4AA□□</b>	2.6	6.5	3	16	0.055	66	78
<b>1LG4 183-4AA□□</b>	2.4	6.7	3.1	16	0.099	65	78
<b>1LG4 186-4AA□□</b>	2.5	6.9	3.2	16	0.12	65	78
<b>1LG4 207-4AA□□</b>	2.5	6.7	3.4	16	0.19	66	79
<b>1LG4 220-4AA□□</b>	2.3	6.7	3.1	16	0.37	66	79
<b>1LG4 223-4AA□□</b>	2.6	7.2	3.2	16	0.45	66	79
<b>1LG4 253-4AA□□</b>	2.4	6.1	2.8	16	0.69	65	78
<b>1LG4 280-4AA□□</b>	2.5	7.1	3	16	1.2	70	84
<b>1LG4 283-4AA□□</b>	2.5	7.4	3	16	1.4	70	84
<b>1LG4 310-4AA□□</b>	2.5	6.4	2.8	16	1.9	70	84
<b>1LG4 313-4AA□□</b>	2.7	6.8	2.9	16	2.3	71	85
<b>1LG4 316-4AA□□</b>	2.7	6.8	2.8	16	2.9	71	85
<b>1LG4 317-4AA□□</b>	2.6	6.5	2.8	16	3.5	71	85

- 1) For connection to 230 V, parallel supply cables are necessary (see catalog part 0 "Introduction", "Connection, circuit and connection box").
- 2) For connection to 400 V, parallel supply cables are necessary (see catalog part 0 "Introduction", "Connection, circuit and connection box").
- 3) If motors 1LG4 183-... to 1LG4 318-... (motor series 1LG4 frame sizes 180 M to 315 L) in types of construction with feet IM B6, IM B7, IM V6 or IM V5 without protective cover are fixed to the wall, it is recommended that the motor feet are supported.
- 4) 1LG4 220-... to 1LG4 318-... motors (motor series 1LG4 frame sizes 225 S to 315 L) are supplied with two screw-in eyebolts in accordance with IM B5, whereby one can be rotated in accordance with IM V1 or IM V3. It is important to note that stress must not be applied perpendicular to the ring plane.
- 5) The "Second shaft extension" option, order code **K16** is not possible.
- 6) Type of construction IM V3 is only possible using type of construction code **9** and order code **M1G**.
- 7) Type of construction IM V6 and IM V5 without protective cover is only possible using type of construction code **9** and order code **M1E** or **M1D**.

# IEC Squirrel-Cage Motors

## Standard motors up to frame size 315 L

Self-ventilated energy-saving motors with improved efficiency – Cast-iron series 1LA6/1LG4

### Selection and ordering data (continued)

Rated output at		Frame size	Operating values at rated output						Power factor at 50 Hz 4/4-load	Rated current at 400 V, 50 Hz	Order No. For Order No. supplements for voltage and type of construction, see table below	Price	Weight IM B3 type of construction approx. m kg
50 Hz	60 Hz		Rated speed at 50 Hz	Rated torque at 50 Hz	Efficiency Class according to CEMEP	Efficiency at 50 Hz 4/4-load	Efficiency at 50 Hz 3/4-load						
$P_{rated}$ kW	$P_{rated}$ kW	FS	$n_{rated}$ rpm	$T_{rated}$ Nm	$\eta_{rated}$ %	$\eta_{rated}$ %	$\cos\phi_{rated}$	$I_{rated}$ A					
<b>6-pole, 1000 rpm at 50 Hz, 1200 rpm at 60 Hz, temperature class 155 (F), IP55 degree of protection</b>													
1.5	1.75	100 L	925	15	74	74	0.75	3.9	<b>1LA6 106-6AA□□</b>		33		
2.2	2.55	112 M	940	22	78	78.5	0.78	5.2	<b>1LA6 113-6AA□□</b>		40		
3	3.45	132 S	950	30	79	79.5	0.76	7.2	<b>1LA6 130-6AA□□</b>		50		
4	4.6	132 M	950	40	80.5	80.5	0.76	9.4	<b>1LA6 133-6AA□□</b>		57		
5.5	6.3	132 M	950	55	83	83	0.76	12.6	<b>1LA6 134-6AA□□</b>		66		
7.5	8.6	160 M	960	75	86	86	0.74	17	<b>1LA6 163-6AA□□</b>		103		
11	12.6	160 L	960	109	87.5	87.5	0.74	24.5	<b>1LA6 166-6AA□□</b>		122		
15	18	180 L	965	148	88.9	90.3	0.83	29.5	<b>1LG4 186-6AA□□</b>		150		
18.5	22	200 L	975	181	89.8	90.2	0.81	36.5	<b>1LG4 206-6AA□□</b>		195		
22	26.5	200 L	975	215	90.3	91	0.81	43.5	<b>1LG4 207-6AA□□</b>		205		
30	36	225 M	978	293	91.8	92.8	0.83	57 <sup>1)</sup>	<b>1LG4 223-6AA□□</b>		280		
37	44.5	250 M	980	361	92.3	93	0.83	70	<b>1LG4 253-6AA□□</b>		370		
45	54	280 S	985	436	92.4	93.1	0.85	83	<b>1LG4 280-6AA□□</b>		475		
55	66	280 M	985	533	92.7	93.3	0.86	100	<b>1LG4 283-6AA□□</b>		510		
75	90	315 S	988	725	93.5	93.7	0.84	138	<b>1LG4 310-6AA□□</b>		685		
90	108	315 M	988	870	93.9	94.2	0.84	164 <sup>1)</sup>	<b>1LG4 313-6AA□□</b>		750		
110	132	315 L	988	1063	94.3	94.6	0.86	196	<b>1LG4 316-6AA□□</b>		890		
132	158	315 L	988	1276	94.8	95	0.86	235	<b>1LG4 317-6AA□□</b>		980		
160	192	315 L	988	1547	95	95.1	0.86	285 <sup>2)</sup>	<b>1LG4 318-6AA□□</b>		1180		

### Order No. supplements

Motor type	Penultimate position: Voltage code						Final position: Type of construction code							
	50 Hz		60 Hz				Without flange	With flange			With standard flange		With special flange	
	230 VΔ/400 VY	400 VΔ/690 VY	500 VY	500 VΔ	460 VY	460 VΔ	IM B3/6/7/8, IM V6, IM V5 without protective cover <sup>3)</sup>	IM B5, IM V1 without protective cover <sup>4)</sup>	IM V1 without protective cover <sup>4)</sup>	IM V1 with protective cover <sup>4)5)</sup>	IM B35	IM B14, IM V19, IM V18 without protective cover	IM B34	IM B14, IM V19, IM V18 without protective cover
	<b>1</b>	<b>6</b>	<b>3</b>	<b>5</b>	<b>1</b>	<b>6</b>	<b>0</b>	<b>1</b>	<b>8</b>	<b>4</b>	<b>6</b>	<b>2</b>	<b>7</b>	<b>3</b>
<b>1LA6 10 - . . . □□</b>	○	○	○	○	○	○	□	✓	–	✓	✓	✓	✓	✓
<b>1LA6 11 - . . . □□</b>	○	○	○	○	○	○	□	✓	–	✓	✓	✓	✓	✓
<b>1LA6 13 - . . . □□</b>	○	○	○	○	○	○	□	✓	–	✓	✓	✓	✓	✓
<b>1LA6 16 - . . . □□</b>	○	○	○	○	○	○	□	✓	–	✓	✓	✓	✓	✓
<b>1LG4 18 - . . . □□</b>	○	○	○	○	○	○	□	✓ <sup>6)</sup>	–	✓	✓	–	–	–
<b>1LG4 20 - . . . □□</b>	○	○	○	○	○	○	□	✓ <sup>6)</sup>	–	✓	✓	–	–	–
<b>1LG4 22 - . . . □□</b>	○	○	○	○	○	○	□	✓ <sup>6)</sup>	–	✓	✓	–	–	–
<b>1LG4 25 - . . . □□</b>	○	○	○	○	○	○	□	✓ <sup>6)</sup>	–	✓	✓	–	–	–
<b>1LG4 28 - . . . □□</b>	○	○	○	○	○	○	□	✓ <sup>6)</sup>	–	✓	✓	–	–	–
<b>1LG4 310 - . . . □□</b>	○	○	○	○	○	○	□	✓ <sup>6)</sup>	–	✓	✓	–	–	–
<b>1LG4 313 - . . . □□</b>														
<b>1LG4 316 - . . . □□</b>	–	○	–	○	–	○	□ <sup>7)</sup>	–	✓	✓	✓	–	–	–
<b>1LG4 317 - . . . □□</b>														
<b>1LG4 318 - . . . □□</b>														

- Standard version
- Without additional charge
- ✓ With additional charge
- Not possible

Order other voltages with voltage code **9** in the penultimate position and the corresponding order code (see "Special versions" in the "Selection and ordering data" under "Voltages").

Order other types of construction with type of construction code **9** in the final position and the corresponding order code (see "Special versions" in the "Selection and ordering data" under "Types of construction").

For footnotes, see Page 2/43 bottom.

# IEC Squirrel-Cage Motors

## Standard motors up to frame size 315 L

Self-ventilated energy-saving motors with improved efficiency – Cast-iron series 1LA6/1LG4

### Selection and ordering data (continued)

Order No.	Locked-rotor torque	Locked-rotor current	Breakdown torque	Torque class	Moment of inertia	Noise at rated output	
	with direct starting torque	as multiple of rated current	torque	CL	$J$ kgm <sup>2</sup>	Measuring surface sound pressure level at 50 Hz $L_{p(A)}$ dB(A)	Sound pressure level at 50 Hz $L_{WA}$ dB(A)
	$T_{LR}/T_{rated}$	$I_{LR}/I_{rated}$	$T_B/T_{rated}$				
<b>6-pole, 1000 rpm at 50 Hz, 1200 rpm at 60 Hz, temperature class 155 (F), IP55 degree of protection</b>							
<b>1LA6 106-6AA□□</b>	2.3	4	2.3	16	0.0047	47	59
<b>1LA6 113-6AA□□</b>	2.2	4.6	2.5	16	0.0091	52	64
<b>1LA6 130-6AA□□</b>	1.9	4.2	2.2	16	0.015	63	75
<b>1LA6 133-6AA□□</b>	2.1	4.5	2.4	16	0.019	63	75
<b>1LA6 134-6AA□□</b>	2.3	5	2.6	16	0.025	63	75
<b>1LA6 163-6AA□□</b>	2.1	4.6	2.5	16	0.044	66	78
<b>1LA6 166-6AA□□</b>	2.3	4.8	2.6	16	0.063	66	78
<b>1LG4 186-6AA□□</b>	2.3	5.3	2.5	16	0.18	57	73
<b>1LG4 206-6AA□□</b>	2.5	5.6	2.5	16	0.24	58	73
<b>1LG4 207-6AA□□</b>	2.6	5.7	2.5	16	0.29	58	73
<b>1LG4 223-6AA□□</b>	2.7	5.6	2.5	16	0.49	59	73
<b>1LG4 253-6AA□□</b>	2.7	6	2.3	16	0.76	60	75
<b>1LG4 280-6AA□□</b>	2.4	6.1	2.4	16	1.1	61	75
<b>1LG4 283-6AA□□</b>	2.5	6.3	2.5	16	1.4	61	75
<b>1LG4 310-6AA□□</b>	2.5	6.5	2.8	16	2.1	63	77
<b>1LG4 313-6AA□□</b>	2.6	6.8	2.9	16	2.5	63	77
<b>1LG4 316-6AA□□</b>	2.5	6.8	2.9	16	3.2	64	78
<b>1LG4 317-6AA□□</b>	3.1	7.3	3	16	4	64	78
<b>1LG4 318-6AA□□</b>	3	7.5	3	16	4.7	65	79

- 1) For connection to 230 V, parallel supply cables are necessary (see catalog part 0 "Introduction", "Connection, circuit and connection box").
- 2) For connection to 400 V, parallel supply cables are necessary (see catalog part 0 "Introduction", "Connection, circuit and connection box").
- 3) If motors 1LG4 183-... to 1LG4 318-... (motor series 1LG4 frame sizes 180 M to 315 L) in types of construction with feet IM B6, IM B7, IM V6 or IM V5 without protective cover are fixed to the wall, it is recommended that the motor feet are supported.
- 4) 1LG4 220-... to 1LG4 318-... motors (motor series 1LG4 frame sizes 225 S to 315 L) are supplied with two screw-in eyebolts in accordance with IM B5, whereby one can be rotated in accordance with IM V1 or IM V3. It is important to note that stress must not be applied perpendicular to the ring plane.
- 5) The "Second shaft extension" option, order code **K16** is not possible.
- 6) Type of construction IM V3 is only possible using type of construction code **9** and order code **M1G**.
- 7) Type of construction IM V6 and IM V5 without protective cover is only possible using type of construction code **9** and order code **M1E** or **M1D**.

# IEC Squirrel-Cage Motors

## Standard motors up to frame size 315 L

Self-ventilated energy-saving motors with improved efficiency – Cast-iron series 1LA6/1LG4

### Selection and ordering data (continued)

Rated output at		Frame size	Operating values at rated output						Order No.	Price	Weight
50 Hz	60 Hz		Rated speed at 50 Hz	Rated torque at 50 Hz	Efficiency Class according to CEMEP	Efficiency at 50 Hz 4/4-load	Efficiency at 50 Hz 3/4-load	Power factor at 50 Hz 4/4-load			
$P_{rated}$ kW	$P_{rated}$ kW	FS	$n_{rated}$ rpm	$T_{rated}$ Nm	$\eta_{rated}$ %	$\eta_{rated}$ %	$\cos\phi_{rated}$	$I_{rated}$ A		$m$ kg	
<b>8-pole, 750 rpm at 50 Hz, 900 rpm at 60 Hz, temperature class 155 (F), IP55 degree of protection</b>											
0.75	0.86	100 L	680	11	66	65	0.76	2.15	<b>1LA6 106-8AB00</b>	29	
1.1	1.3	100 L	680	15	72	72	0.76	2.9	<b>1LA6 107-8AB00</b>	32	
1.5	1.75	112 M	705	20	74	74	0.76	3.85	<b>1LA6 113-8AB00</b>	39	
2.2	2.55	132 S	700	30	75	75	0.74	5.7	<b>1LA6 130-8AB00</b>	50	
3	3.45	132 M	700	41	77	77.5	0.74	7.6	<b>1LA6 133-8AB00</b>	57	
4	4.6	160 M	715	53	80	80	0.72	10	<b>1LA6 163-8AB00</b>	91	
5.5	6.3	160 M	710	74	83.5	83.5	0.73	13	<b>1LA6 164-8AB00</b>	102	
7.5	8.6	160 L	715	100	85.5	85.5	0.72	17.6	<b>1LA6 166-8AB00</b>	122	
11	13.2	180 L	725	145	87.5	88.3	0.73	25	<b>1LG4 186-8AB00</b>	150	
15	18	200 L	725	198	87.7	88.4	0.76	32.5	<b>1LG4 207-8AB00</b>	205	
18.5	22	225 S	730	242	89.4	90.4	0.78	38.5	<b>1LG4 220-8AB00</b>	270	
22	26.5	225 M	730	288	89.7	90.7	0.79	45	<b>1LG4 223-8AB00</b>	290	
30	36	250 M	730	392	91.4	92.2	0.81	58	<b>1LG4 253-8AB00</b>	385	
37	44.5	280 S	735	481	92	92.8	0.81	72	<b>1LG4 280-8AB00</b>	475	
45	54	280 M	735	585	92.4	93.3	0.81	87	<b>1LG4 283-8AB00</b>	515	
55	66	315 S	740	710	93	93.4	0.81	106	<b>1LG4 310-8AB00</b>	680	
75	90	315 M	738	971	93.3	94	0.83	140	<b>1LG4 313-8AB00</b>	745	
90	108	315 L	738	1165	93.4	94	0.83	168	<b>1LG4 316-8AB00</b>	865	
110	132	315 L	738	1423	94	94.4	0.83	205	<b>1LG4 317-8AB00</b>	1020	
132	158	315 L	738	1708	94.2	94.6	0.83	245	<b>1LG4 318-8AB00</b>	1100	

### Order No. supplements

Motor type	Penultimate position: Voltage code						Final position: Type of construction code							
	50 Hz		60 Hz				Without flange	With flange		With standard flange		With special flange		
	230 VΔ/400 VY	400 VΔ/690 VY	500 VY	500 VΔ	460 VY	460 VΔ	IM B3/6/7/8, IM V6, IM V5 without protective cover 1)	IM B5, IM V1 without protective cover 2)	IM V1 without protective cover 2)	IM V1 with protective cover 2)3)	IM B35	IM B14, IM V19, IM V18 without protective cover	IM B34	IM B14, IM V19, IM V18 without protective cover
	<b>1</b>	<b>6</b>	<b>3</b>	<b>5</b>	<b>1</b>	<b>6</b>	<b>0</b>	<b>1</b>	<b>8</b>	<b>4</b>	<b>6</b>	<b>2</b>	<b>7</b>	<b>3</b>
<b>1LA6 10</b> . . . . . <b>00</b>	○	○	○	○	○	○	□	✓	–	✓	✓	✓	✓	✓
<b>1LA6 11</b> . . . . . <b>00</b>	○	○	○	○	○	○	□	✓	–	✓	✓	✓	✓	✓
<b>1LA6 13</b> . . . . . <b>00</b>	○	○	○	○	○	○	□	✓	–	✓	✓	✓	✓	✓
<b>1LA6 16</b> . . . . . <b>00</b>	○	○	○	○	○	○	□	✓	–	✓	✓	✓	✓	✓
<b>1LG4 18</b> . . . . . <b>00</b>	○	○	○	○	○	○	□	✓ <sup>4)</sup>	–	✓	✓	–	–	–
<b>1LG4 20</b> . . . . . <b>00</b>	○	○	○	○	○	○	□	✓ <sup>4)</sup>	–	✓	✓	–	–	–
<b>1LG4 22</b> . . . . . <b>00</b>	○	○	○	○	○	○	□	✓ <sup>4)</sup>	–	✓	✓	–	–	–
<b>1LG4 25</b> . . . . . <b>00</b>	○	○	○	○	○	○	□	✓ <sup>4)</sup>	–	✓	✓	–	–	–
<b>1LG4 28</b> . . . . . <b>00</b>	○	○	○	○	○	○	□	✓ <sup>4)</sup>	–	✓	✓	–	–	–
<b>1LG4 310</b> . . . . . <b>00</b>	○	○	○	○	○	○	□	✓ <sup>4)</sup>	–	✓	✓	–	–	–
<b>1LG4 313</b> . . . . . <b>00</b>	○	○	○	○	○	○	□	✓ <sup>4)</sup>	–	✓	✓	–	–	–
<b>1LG4 316</b> . . . . . <b>00</b>	–	○	–	○	–	○	□ <sup>5)</sup>	–	✓	✓	✓	–	–	–
<b>1LG4 317</b> . . . . . <b>00</b>	–	○	–	○	–	○	□ <sup>5)</sup>	–	✓	✓	✓	–	–	–
<b>1LG4 318</b> . . . . . <b>00</b>	–	○	–	○	–	○	□ <sup>5)</sup>	–	✓	✓	✓	–	–	–

- Standard version
- Without additional charge
- ✓ With additional charge
- Not possible

Order other voltages with voltage code **9** in the penultimate position and the corresponding order code (see “Special versions” in the “Selection and ordering data” under “Voltages”).

Order other types of construction with type of construction code **9** in the final position and the corresponding order code (see “Special versions” in the “Selection and ordering data” under “Types of construction”).

For footnotes, see Page 2/45 bottom.

# IEC Squirrel-Cage Motors

## Standard motors up to frame size 315 L

Self-ventilated energy-saving motors with improved efficiency – Cast-iron series 1LA6/1LG4

### Selection and ordering data (continued)

Order No.	Locked-rotor torque	Locked-rotor current	Breakdown torque	Torque class	Moment of inertia	Noise at rated output	
	with direct starting torque	as multiple of rated current	torque	CL	$J$ kgm <sup>2</sup>	Measuring surface sound pressure level at 50 Hz $L_{p(A)}$ dB(A)	Sound pressure level at 50 Hz $L_{WA}$ dB(A)
	$T_{LR}/T_{rated}$	$I_{LR}/I_{rated}$	$T_B/T_{rated}$				
<b>8-pole, 750 rpm at 50 Hz, 900 rpm at 60 Hz, temperature class 155 (F), IP55 degree of protection</b>							
<b>1LA6 106-8AB□□</b>	1.6	3	1.9	13	0.0051	45	57
<b>1LA6 107-8AB□□</b>	1.8	3.3	2.1	13	0.0063	45	57
<b>1LA6 113-8AB□□</b>	1.8	3.7	2.1	13	0.013	49	61
<b>1LA6 130-8AB□□</b>	1.9	3.9	2.3	13	0.014	53	65
<b>1LA6 133-8AB□□</b>	2.1	4.1	2.4	13	0.019	53	65
<b>1LA6 163-8AB□□</b>	2.2	4.5	2.6	13	0.036	63	75
<b>1LA6 164-8AB□□</b>	2.3	4.7	2.7	13	0.046	63	75
<b>1LA6 166-8AB□□</b>	2.7	5.3	3	13	0.064	63	75
<b>1LG4 186-8AB□□</b>	1.7	4.2	2.1	13	0.17	66	79
<b>1LG4 207-8AB□□</b>	2.2	4.9	2.6	13	0.29	67	70
<b>1LG4 220-8AB□□</b>	2.3	5.5	2.7	13	0.48	57	70
<b>1LG4 223-8AB□□</b>	2.3	5.6	2.8	13	0.55	54	73
<b>1LG4 253-8AB□□</b>	2.3	5.5	2.6	13	0.84	55	73
<b>1LG4 280-8AB□□</b>	2.2	5	2.1	13	1.1	56	74
<b>1LG4 283-8AB□□</b>	2.2	5.1	2.1	13	1.4	58	74
<b>1LG4 310-8AB□□</b>	2.2	5.8	2.6	13	2.1	64	78
<b>1LG4 313-8AB□□</b>	2.2	5.7	2.6	13	2.5	64	78
<b>1LG4 316-8AB□□</b>	2.2	5.8	2.7	13	3.1	64	78
<b>1LG4 317-8AB□□</b>	2.4	6.1	2.8	13	3.9	64	78
<b>1LG4 318-8AB□□</b>	2.5	6.5	2.9	13	4.5	64	78

- 1) If motors 1LG4 183-... to 1LG4 318-... (motor series 1LG4 frame sizes 180 M to 315 L) in types of construction with feet IM B6, IM B7, IM V6 or IM V5 without protective cover are fixed to the wall, it is recommended that the motor feet are supported.
- 2) 1LG4 220-... to 1LG4 318-... motors (motor series 1LG4 frame sizes 225 S to 315 L) are supplied with two screw-in eyebolts in accordance with IM B5, whereby one can be rotated in accordance with IM V1 or IM V3. It is important to note that stress must not be applied perpendicular to the ring plane.

- 3) The "Second shaft extension" option, order code **K16** is not possible.
- 4) Type of construction IM V3 is only possible using type of construction code **9** and order code **M1G**.
- 5) Type of construction IM V6 and IM V5 without protective cover is only possible using type of construction code **9** and order code **M1E** or **M1D**.

# IEC Squirrel-Cage Motors

## Standard motors up to frame size 315 L

Self-ventilated motors with increased output –  
Cast-iron series 1LG4

### Selection and ordering data

Rated output at		Frame size	Operating values at rated output						Order No.	Price	Weight IM B3 type of construction approx. m kg
50 Hz	60 Hz		Rated speed at 50 Hz	Rated torque at 50 Hz	Efficiency at 50 Hz 4/4-load	Efficiency at 50 Hz 3/4-load	Power factor at 50 Hz 4/4-load	Rated current at 400 V, 50 Hz			
$P_{rated}$ kW	$P_{rated}$ kW	FS	$n_{rated}$ rpm	$T_{rated}$ Nm	$\eta_{rated}$ %	$\eta_{rated}$ %	$\cos\phi_{rated}$	$I_{rated}$ A	For Order No. supplements for voltage and type of construction, see table below		
<b>2-pole, 3000 rpm at 50 Hz, 3600 rpm at 60 Hz, temperature class 155 (F), IP55 degree of protection, with increased output, used acc. to temperature class 130 (B)</b>											
30	33.5	180 L	2950	97	92.8	92.9	0.86	54 <sup>1)</sup>	<b>1LG4 188-2AA□□</b>	175	
45	51	200 L	2955	145	93.6	93.7	0.89	78 <sup>1)</sup>	<b>1LG4 208-2AA□□</b>	255	
55	62	225 M	2960	177	94.8	95	0.89	94 <sup>1)</sup>	<b>1LG4 228-2AA□□</b>	335	
75	84	250 M	2970	241	94.5	94.5	0.88	130 <sup>1)</sup>	<b>1LG4 258-2AA□□</b>	420	
110	123	280 M	2975	353	95.5	95.6	0.9	184 <sup>1)</sup>	<b>1LG4 288-2AB□□</b>	630	
<b>4-pole, 1500 rpm at 50 Hz, 1800 rpm at 60 Hz, temperature class 155 (F), IP55 degree of protection, with increased output, used acc. to temperature class 130 (B)</b>											
30	34.5	180 L	1465	196	91.7	91.9	0.8	59 <sup>1)</sup>	<b>1LG4 188-4AA□□</b>	180	
37	42.5	200 L	1465	241	92.5	92.8	0.83	70 <sup>1)</sup>	<b>1LG4 208-4AA□□</b>	230	
55	63	225 M	1475	356	93.4	93.9	0.86	99 <sup>1)</sup>	<b>1LG4 228-4AA□□</b>	330	
75	86	250 M	1482	483	94.3	94.4	0.85	136 <sup>1)</sup>	<b>1LG4 258-4AA□□</b>	460	
110	127	280 M	1488	706	95.2	94.9	0.84	198 <sup>1)</sup>	<b>1LG4 288-4AA□□</b>	680	
<b>6-pole, 1000 rpm at 50 Hz, 1200 rpm at 60 Hz, temperature class 155 (F), IP55 degree of protection, with increased output, used acc. to temperature class 130 (B)</b>											
18.5	22	180 L	970	182	89.6	90.3	0.8	37.5 <sup>1)</sup>	<b>1LG4 188-6AA□□</b>	175	
30	36	200 L	975	294	90.9	91.3	0.8	60 <sup>1)</sup>	<b>1LG4 208-6AA□□</b>	245	
37	44.5	225 M	978	361	92.2	93	0.83	70 <sup>1)</sup>	<b>1LG4 228-6AA□□</b>	325	
45	54	250 M	982	438	93.3	93.8	0.83	84	<b>1LG4 258-6AA□□</b>	405	
75	90	280 M	985	727	93.8	94.3	0.85	136 <sup>1)</sup>	<b>1LG4 288-6AA□□</b>	570	
<b>8-pole, 750 rpm at 50 Hz, 900 rpm at 60 Hz, temperature class 155 (F), IP55 degree of protection, with increased output, used acc. to temperature class 130 (B)</b>											
15	18	180 L	720	199	87.8	88.5	0.73	34 <sup>1)</sup>	<b>1LG4 188-8AB□□</b>	165	
18.5	22	200 L	725	244	88.3	89.2	0.78	39	<b>1LG4 208-8AB□□</b>	230	
30	36	225 M	730	392	90.4	91.2	0.79	61 <sup>1)</sup>	<b>1LG4 228-8AB□□</b>	340	
37	44.5	250 M	730	484	91.9	92.8	0.82	71	<b>1LG4 258-8AB□□</b>	430	
55	66	280 M	735	715	92.9	93.7	0.81	106	<b>1LG4 288-8AB□□</b>	565	

### Order No. supplements

Motor type	Penultimate position: Voltage code				Final position: Type of construction code								
	50 Hz		60 Hz		Without flange		With flange		With standard flange		With special flange		
	230 VΔ/400 VY	400 VΔ/690 VY	500 VY	500 VΔ	460 VY	460 VΔ	IM B3/6/7/8, IM V6, IM V5 without protective cover <sup>2)</sup>	IM B5, IM V1 without protective cover <sup>3)4)</sup>	IM V1 with protective cover <sup>3)4)</sup>	IM B35	IM B14, IM V19, IM V18 without protective cover	IM B14, IM V19, IM V18 without protective cover	
	<b>1</b>	<b>6</b>	<b>3</b>	<b>5</b>	<b>1</b>	<b>6</b>	<b>0</b>	<b>1</b>	<b>4</b>	<b>6</b>	<b>2</b>	<b>7</b>	<b>3</b>
<b>1LG4 18 - . . . □□</b>	○	○	○	○	○	○	□	✓ <sup>5)</sup>	✓	✓	-	-	-
<b>1LG4 20 - . . . □□</b>	○	○	○	○	○	○	□	✓ <sup>5)</sup>	✓	✓	-	-	-
<b>1LG4 22 - . . . □□</b>	○	○	○	○	○	○	□	✓ <sup>5)</sup>	✓	✓	-	-	-
<b>1LG4 25 - . . . □□</b>	○	○	○	○	○	○	□	✓ <sup>5)</sup>	✓	✓	-	-	-
<b>1LG4 28 - . . . □□</b>	○	○	○	○	○	○	□	✓ <sup>5)</sup>	✓	✓	-	-	-

- Standard version
- Without additional charge
- ✓ With additional charge
- Not possible

Order other voltages with voltage code **9** in the penultimate position and the corresponding order code (see "Special versions" in the "Selection and ordering data" under "Voltages").

Order other types of construction with type of construction code **9** in the final position and the corresponding order code (see "Special versions" in the "Selection and ordering data" under "Types of construction").

- 1) For connection to 230 V, parallel supply cables are necessary (see catalog part 0 "Introduction", "Connection, circuit and connection box").
- 2) If motors 1LG4 188-... to 1LG4 288-... (motor series 1LG4 frame sizes 180 L to 280 M) in types of construction with feet IM B6, IM B7, IM V6 or IM V5 without protective cover are fixed to the wall, it is recommended that the motor feet are supported.

- 3) 1LG4 220-... to 1LG4 288-... motors (motor series 1LG4 frame sizes 225 M to 280 M) are supplied with two screw-in eyebolts in accordance with IM B 5, whereby one can be rotated in accordance with IM V1 or IM V3. It is important to note that stress must not be applied perpendicular to the ring plane.
- 4) The "Second shaft extension" option, order code **K16** is not possible.
- 5) Type of construction IM V3 is only possible using type of construction code **9** and order code **M1G**.



# IEC Squirrel-Cage Motors

## Standard motors up to frame size 315 L

Self-ventilated motors with increased output –  
Cast-iron series 1LG4

### Selection and ordering data (continued)

Order No.	Locked-rotor torque	Locked-rotor current	Breakdown torque	Torque class	Moment of inertia	Noise at rated output	
	with direct starting torque	as multiple of rated current	torque	CL	$J$ kgm <sup>2</sup>	Measuring surface sound pressure level at 50 Hz $L_{pFA}$ dB(A)	Sound pressure level at 50 Hz $L_{WA}$ dB(A)
	$T_{LR}/T_{rated}$	$I_{LR}/I_{rated}$	$T_B/T_{rated}$				
<b>2-pole, 3000 rpm at 50 Hz, 3600 rpm at 60 Hz, temperature class 155 (F), IP55 degree of protection, with increased output, used acc. to temperature class 130 (B)</b>							
<b>1LG4 188-2AA□□</b>	2.4	7.1	3.4	16	0.09	71	84
<b>1LG4 208-2AA□□</b>	2.5	6.9	3.2	16	0.18	73	86
<b>1LG4 228-2AA□□</b>	2.6	7.3	3.2	16	0.27	73	86
<b>1LG4 258-2AA□□</b>	2.4	7.1	3.1	16	0.48	74	87
<b>1LG4 288-2AB□□</b>	2.5	7	3	13	1	74	87
<b>4-pole, 1500 rpm at 50 Hz, 1800 rpm at 60 Hz, temperature class 155 (F), IP55 degree of protection, with increased output, used acc. to temperature class 130 (B)</b>							
<b>1LG4 188-4AA□□</b>	2.6	6.3	2.9	16	0.14	65	78
<b>1LG4 208-4AA□□</b>	2.6	6.5	3	16	0.23	66	79
<b>1LG4 228-4AA□□</b>	2.5	6.5	2.7	16	0.49	66	79
<b>1LG4 258-4AA□□</b>	2.5	7	3	16	0.86	68	81
<b>1LG4 288-4AA□□</b>	2.8	7.9	3.3	16	1.71	70	84
<b>6-pole, 1000 rpm at 50 Hz, 1200 rpm at 60 Hz, temperature class 155 (F), IP55 degree of protection, with increased output, used acc. to temperature class 130 (B)</b>							
<b>1LG4 188-6AA□□</b>	2.3	4.9	2.4	16	0.2	60	73
<b>1LG4 208-6AA□□</b>	2.6	5.8	2.6	16	0.36	61	74
<b>1LG4 228-6AA□□</b>	2.5	5.9	2.8	16	0.62	61	74
<b>1LG4 258-6AA□□</b>	2.7	6.3	2.3	16	0.93	61	74
<b>1LG4 288-6AA□□</b>	3	6.8	2.8	16	1.65	61	74
<b>8-pole, 750 rpm at 50 Hz, 900 rpm at 60 Hz, temperature class 155 (F), IP55 degree of protection, with increased output, used acc. to temperature class 130 (B)</b>							
<b>1LG4 188-8AB□□</b>	2	4.5	2.4	13	0.21	69	82
<b>1LG4 208-8AB□□</b>	2.4	5.2	2.6	13	0.37	58	71
<b>1LG4 228-8AB□□</b>	2.6	5.6	2.8	13	0.66	61	74
<b>1LG4 258-8AB□□</b>	2.4	5.6	2.6	13	1.06	55	68
<b>1LG4 288-8AB□□</b>	2.4	5.6	2.3	13	1.63	58	71

# IEC Squirrel-Cage Motors

## Standard motors up to frame size 315 L

Self-ventilated energy-saving motors with high efficiency – Cast-iron series 1LG6

### Selection and ordering data

Rated output at 50 Hz	Frame size	Operating values at rated output							Order No.	Price	Weight IM B3 type of construction approx. m kg
		Rated speed at 50 Hz	Rated torque at 50 Hz	Efficiency Class according to CEMEP	Efficiency at 50 Hz 4/4-load	Efficiency at 50 Hz 3/4-load	Power factor at 50 Hz 4/4-load	Rated current at 400 V, 50 Hz			
$P_{rated}$ kW	FS	$n_{rated}$ rpm	$T_{rated}$ Nm	EFF I	$\eta_{rated}$ %	$\eta_{rated}$ %	$\cos\phi_{rated}$	$I_{rated}$ A	For Order No. supplements for voltage and type of construction, see table below		
<b>2-pole, 3000 rpm at 50 Hz, temperature class 155 (F), IP55 degree of protection, for use according to CEMEP</b>											
22	180 M	2955	71	EFF 1	94.1	94.5	0.88	38.5 <sup>1)</sup>	<b>1LG6 183-2AAQQ</b>	180	
30	200 L	2960	97	EFF 1	93.5	93.4	0.88	53 <sup>1)</sup>	<b>1LG6 206-2AAQQ</b>	225	
37	200 L	2960	119	EFF 1	94.1	94	0.89	64 <sup>1)</sup>	<b>1LG6 207-2AAQQ</b>	255	
45	225 M	2965	145	EFF 1	94.9	95.1	0.89	77 <sup>1)</sup>	<b>1LG6 223-2AAQQ</b>	330	
55	250 M	2975	177	EFF 1	95.3	95.3	0.9	93	<b>1LG6 253-2AAQQ</b>	420	
75	280 S	2975	241	EFF 1	95.2	95.2	0.89	128 <sup>1)</sup>	<b>1LG6 280-2ABQQ</b>	530	
90	280 M	2978	289	EFF 1	95.6	95.7	0.9	150 <sup>1)</sup>	<b>1LG6 283-2ABQQ</b>	615	
110	315 S	2982	352		95.8	95.7	0.91	182 <sup>1)</sup>	<b>1LG6 310-2ABQQ</b>	790	
132	315 M	2982	423		96	95.9	0.91	220 <sup>1)</sup>	<b>1LG6 313-2ABQQ</b>	915	
160	315 L	2982	512		96.4	96.4	0.92	260	<b>1LG6 316-2ABQQ</b>	1055	
200	315 L	2982	641		96.5	96.5	0.93	320	<b>1LG6 317-2ABQQ</b>	1245	
<b>4-pole, 1500 rpm at 50 Hz, temperature class 155 (F), IP55 degree of protection, for use according to CEMEP</b>											
18.5	180 M	1470	120	EFF 1	92.6	93.2	0.83	34.5 <sup>1)</sup>	<b>1LG6 183-4AAQQ</b>	155	
22	180 L	1470	143	EFF 1	93.2	93.5	0.84	40.5 <sup>1)</sup>	<b>1LG6 186-4AAQQ</b>	180	
30	200 L	1470	195	EFF 1	93.3	93.4	0.85	55 <sup>1)</sup>	<b>1LG6 207-4AAQQ</b>	225	
37	225 S	1480	239	EFF 1	94	94.4	0.85	67 <sup>1)</sup>	<b>1LG6 220-4AAQQ</b>	290	
45	225 M	1480	290	EFF 1	94.5	94.7	0.85	81 <sup>1)</sup>	<b>1LG6 223-4AAQQ</b>	330	
55	250 M	1485	354	EFF 1	95.1	95.3	0.87	96	<b>1LG6 253-4AAQQ</b>	460	
75	280 S	1485	482	EFF 1	95.1	95.2	0.87	130 <sup>1)</sup>	<b>1LG6 280-4AAQQ</b>	575	
90	280 M	1486	578	EFF 1	95.4	95.5	0.86	158 <sup>1)</sup>	<b>1LG6 283-4AAQQ</b>	675	
110	315 S	1488	706		95.9	96	0.87	190 <sup>1)</sup>	<b>1LG6 310-4AAQQ</b>	810	
132	315 M	1488	847		96.1	96.2	0.88	225 <sup>1)</sup>	<b>1LG6 313-4AAQQ</b>	965	
160	315 L	1490	1026		96.3	96.4	0.88	275 <sup>2)</sup>	<b>1LG6 316-4AAQQ</b>	1105	
200	315 L	1490	1282		96.4	96.5	0.88	340 <sup>2)</sup>	<b>1LG6 317-4AAQQ</b>	1305	

### Order No. supplements

Motor type	Penultimate position: Voltage code				Final position: Type of construction code							
	50 Hz				Without flange	With flange				With standard flange		With special flange
	230 VΔ/400 VY	400 VΔ/690 VY	500 VY	500 VΔ	IM B3/6/7/8, IM V6, IM V5 without protective cover <sup>3)</sup>	IM B5, IM V1 without protective cover <sup>4)</sup>	IM V1 without protective cover <sup>4)</sup>	IM V1 with protective cover <sup>4) 6)</sup>	IM B35	IM B14, IM V19, IM V18 without protective cover	IM B34	IM B14, IM V19, IM V18 without protective cover
	1	6	3	5	0	1	8	4	6	2	7	3
<b>1LG6 18</b> - . . . . □□	○	○	○	○	□	✓	-	✓	✓	-	-	-
<b>1LG6 20</b> - . . . . □□	○	○	○	○	□	✓	-	✓	✓	-	-	-
<b>1LG6 22</b> - . . . . □□	○	○	○	○	□	✓	-	✓	✓	-	-	-
<b>1LG6 25</b> - . . . . □□	○	○	○	○	□	✓	-	✓	✓	-	-	-
<b>1LG6 28</b> - . . . . □□	○	○	○	○	□	✓	-	✓	✓	-	-	-
<b>1LG6 310</b> - . . . . □□	○	○	○	○	□	✓	-	✓	✓	-	-	-
<b>1LG6 313</b> - . . . . □□	○	○	○	○	□	✓	-	✓	✓	-	-	-
<b>1LG6 316</b> - . . . . □□	-	○	-	○	□ <sup>7)</sup>	-	✓ <sup>8)</sup>	✓ <sup>8)</sup>	✓	-	-	-
<b>1LG6 317</b> - . . . . □□	-	-	-	-	-	-	-	-	-	-	-	-

- Standard version
- Without additional charge
- ✓ With additional charge
- Not possible

Order other voltages with voltage code **9** in the penultimate position and the corresponding order code (see "Special versions" in the "Selection and ordering data" under "Voltages").

Order other types of construction with type of construction code **9** in the final position and the corresponding order code (see "Special versions" in the "Selection and ordering data" under "Types of construction").

For footnotes, see Page 2/49 bottom.

# IEC Squirrel-Cage Motors

## Standard motors up to frame size 315 L

Self-ventilated energy-saving motors with high efficiency – Cast-iron series 1LG6

### Selection and ordering data (continued)

Order No.	Locked-rotor torque with direct starting torque	Locked-rotor current as multiple of rated current	Breakdown torque torque	Torque class	Moment of inertia	Noise at rated output	
	$T_{LR}/T_{rated}$	$I_{LR}/I_{rated}$	$T_B/T_{rated}$	CL	$J$ kgm <sup>2</sup>	Measuring surface sound pressure level at 50 Hz $L_{pFA}$ dB(A)	Sound pressure level at 50 Hz $L_{WA}$ dB(A)
<b>2-pole, 3000 rpm at 50 Hz, temperature class 155 (F), IP55 degree of protection, for use according to CEMEP</b>							
<b>1LG6 183-2AA□□</b>	2.5	7.2	3.4	16	0.086	67	80
<b>1LG6 206-2AA□□</b>	2.4	7	3.3	16	0.15	71	84
<b>1LG6 207-2AA□□</b>	2.5	7.2	3.3	16	0.18	71	84
<b>1LG6 223-2AA□□</b>	2.5	7.3	3.2	16	0.27	71	84
<b>1LG6 253-2AA□□</b>	2.4	6.8	3	16	0.47	71	84
<b>1LG6 280-2AB□□</b>	2.5	7	3	13	0.83	73	86
<b>1LG6 283-2AB□□</b>	2.6	7.6	3.1	13	1	73	86
<b>1LG6 310-2AB□□</b>	2.4	6.9	2.8	13	1.4	76	89
<b>1LG6 313-2AB□□</b>	2.6	7.1	2.9	13	1.6	76	89
<b>1LG6 316-2AB□□</b>	2.5	7.1	2.9	13	2.1	76	89
<b>1LG6 317-2AB□□</b>	2.5	6.9	2.8	13	2.5	76	89
<b>4-pole, 1500 rpm at 50 Hz, temperature class 155 (F), IP55 degree of protection, for use according to CEMEP</b>							
<b>1LG6 183-4AA□□</b>	2.5	6.4	3	16	0.12	60	73
<b>1LG6 186-4AA□□</b>	2.5	6.7	3.1	16	0.14	60	73
<b>1LG6 207-4AA□□</b>	2.6	6.7	3.3	16	0.23	62	75
<b>1LG6 220-4AA□□</b>	2.7	6.8	3	16	0.4	60	73
<b>1LG6 223-4AA□□</b>	2.8	6.9	3	16	0.49	60	73
<b>1LG6 253-4AA□□</b>	2.6	7.5	3	16	0.86	65	78
<b>1LG6 280-4AA□□</b>	2.5	6.8	2.9	16	1.4	67	80
<b>1LG6 283-4AA□□</b>	2.7	7.5	3.1	16	1.7	68	82
<b>1LG6 310-4AA□□</b>	2.7	7.1	2.9	16	2.3	68	82
<b>1LG6 313-4AA□□</b>	2.7	7.3	2.9	16	2.9	69	83
<b>1LG6 316-4AA□□</b>	3	7.4	3	16	3.5	69	83
<b>1LG6 317-4AA□□</b>	3.2	7.6	3	16	4.2	69	83

The motors can also be used for 60 Hz according to EPACT, see Pages 2/52 to 2/57.

- 1) For connection to 230 V, parallel supply cables are necessary (see catalog part 0 "Introduction", "Connection, circuit and connection box").
- 2) For connection to 400 V, parallel supply cables are necessary (see catalog part 0 "Introduction", "Connection, circuit and connection box").
- 3) If motors 1LG6 183-... to 1LG6 317-... (motor series 1LG6 frame sizes 180 M to 315 L) in types of construction with feet IM B6, IM B7, IM V6 or IM V5 without protective cover are fixed to the wall, it is recommended that the motor feet are supported.
- 4) 1LG6 220-... to 1LG6 317-... motors (motor series 1LG6 frame sizes 225 S to 315 L) are supplied with two screw-in eyebolts in accordance with IM B5, whereby one can be rotated in accordance with IM V1 or IM V3. It is important to note that stress must not be applied perpendicular to the ring plane.
- 5) Type of construction IM V3 is only possible using type of construction code **9** and order code **M1G**.
- 6) The "Second shaft extension" option, order code **K16** is not possible.
- 7) Type of construction IM V6 and IM V5 without protective cover is only possible using type of construction code **9** and order code **M1E** or **M1D**.
- 8) 2-pole motors in 60 Hz version available on request.

# IEC Squirrel-Cage Motors

## Standard motors up to frame size 315 L

Self-ventilated energy-saving motors with high efficiency – Cast-iron series 1LG6

### Selection and ordering data (continued)

Rated output at 50 Hz	Frame size	Operating values at rated output						Power factor at 50 Hz 4/4-load	Rated current at 400 V, 50 Hz	Order No.	Price	Weight IM B3 type of construction approx. m kg
		Rated speed at 50 Hz	Rated torque at 50 Hz	Efficiency Class according to CEMEP	Efficiency at 50 Hz 4/4-load	Efficiency at 50 Hz 3/4-load	Efficiency at 50 Hz 2/4-load					
$P_{rated}$ kW	FS	$n_{rated}$ rpm	$T_{rated}$ Nm	$\eta_{rated}$ %	$\eta_{rated}$ %	$\eta_{rated}$ %	$\cos\phi_{rated}$	$I_{rated}$ A	For Order No. supplements for voltage and type of construction, see table below			
<b>6-pole, 1000 rpm at 50 Hz, temperature class 155 (F), IP55 degree of protection, for use according to CEMEP</b>												
15	180 L	975	147		90.9	91.7	0.81	29.5	<b>1LG6 186-6AAQQ</b>		175	
18.5	200 L	978	181		91.2	91.8	0.81	36	<b>1LG6 206-6AAQQ</b>		210	
22	200 L	978	215		91.9	92.5	0.82	42	<b>1LG6 207-6AAQQ</b>		240	
30	225 M	980	292		93.2	93.7	0.83	56 <sup>1)</sup>	<b>1LG6 223-6AAQQ</b>		325	
37	250 M	985	359		93.7	94.1	0.83	69	<b>1LG6 253-6AAQQ</b>		405	
45	280 S	988	435		94.4	94.6	0.85	81	<b>1LG6 280-6AAQQ</b>		520	
55	280 M	988	532		94.6	94.8	0.85	99	<b>1LG6 283-6AAQQ</b>		570	
75	315 S	990	723		95	95	0.83	138	<b>1LG6 310-6AAQQ</b>		760	
90	315 M	990	868		95.3	95.4	0.85	160 <sup>1)</sup>	<b>1LG6 313-6AAQQ</b>		935	
110	315 L	990	1061		95.6	95.7	0.85	196	<b>1LG6 316-6AAQQ</b>		1010	
132	315 L	990	1273		95.8	95.8	0.85	235	<b>1LG6 317-6AAQQ</b>		1180	
160	315 L	990	1543		95.8	95.9	0.86	280 <sup>2)</sup>	<b>1LG6 318-6AAQQ</b>		1245	
<b>8-pole, 750 rpm at 50 Hz, temperature class 155 (F), IP55 degree of protection, for use according to CEMEP</b>												
11	180 L	725	145		88.7	89.6	0.76	23.5	<b>1LG6 186-8ABQQ</b>		165	
15	200 L	725	198		89.3	89.8	0.8	30.5	<b>1LG6 207-8ABQQ</b>		235	
18.5	225 S	730	242		91.1	91.8	0.81	36	<b>1LG6 220-8ABQQ</b>		295	
22	225 M	730	288		91.6	92.1	0.81	43	<b>1LG6 223-8ABQQ</b>		335	
30	250 M	735	390		92.8	93.3	0.82	57	<b>1LG6 253-8ABQQ</b>		435	
37	280 S	738	479		93.1	93.3	0.81	71	<b>1LG6 280-8ABQQ</b>		510	
45	280 M	738	582		93.7	94	0.81	86	<b>1LG6 283-8ABQQ</b>		560	
55	315 S	740	710		94.3	94.4	0.82	102	<b>1LG6 310-8ABQQ</b>		750	
75	315 M	740	968		94.5	94.7	0.83	138	<b>1LG6 313-8ABQQ</b>		840	
90	315 L	740	1161		94.7	95.1	0.84	164	<b>1LG6 316-8ABQQ</b>		1005	
110	315 L	740	1420		94.8	95.1	0.84	200	<b>1LG6 317-8ABQQ</b>		1100	
132	315 L	740	1704		94.9	95.2	0.84	240	<b>1LG6 318-8ABQQ</b>		1270	

### Order No. supplements

Motor type	Penultimate position: Voltage code				Final position: Type of construction code							
	50 Hz				Without flange	With flange			With standard flange	With special flange		
	230 VΔ/400 VY	400 VΔ/690 VY	500 VY	500 VΔ	IM B3/6/7/8, IM V6, IM V5 without protective cover <sup>3)</sup>	IM B5, IM V1 without protective cover IM V3 <sup>4) 5)</sup>	IM V1 without protective cover <sup>4)</sup>	IM V1 with protective cover <sup>4) 6)</sup>	IM B35	IM B14, IM V19, IM V18 without protective cover	IM B34	IM B14, IM V19, IM V18 without protective cover
	1	6	3	5	0	1	8	4	6	2	7	3
<b>1LG6 18 - . . . QQ</b>	○	○	○	○	□	✓	–	✓	✓	–	–	–
<b>1LG6 20 - . . . QQ</b>	○	○	○	○	□	✓	–	✓	✓	–	–	–
<b>1LG6 22 - . . . QQ</b>	○	○	○	○	□	✓	–	✓	✓	–	–	–
<b>1LG6 25 - . . . QQ</b>	○	○	○	○	□	✓	–	✓	✓	–	–	–
<b>1LG6 28 - . . . QQ</b>	○	○	○	○	□	✓	–	✓	✓	–	–	–
<b>1LG6 310 - . . . QQ</b>	○	○	○	○	□	✓	–	✓	✓	–	–	–
<b>1LG6 313 - . . . QQ</b>	○	○	○	○	□	✓	–	✓	✓	–	–	–
<b>1LG6 316 - . . . QQ</b>	–	○	–	○	□ <sup>7)</sup>	–	✓	✓	✓	–	–	–
<b>1LG6 317 - . . . QQ</b>	–	○	–	○	□ <sup>7)</sup>	–	✓	✓	✓	–	–	–
<b>1LG6 318 - . . . QQ</b>	–	○	–	○	□ <sup>7)</sup>	–	✓	✓	✓	–	–	–

- Standard version
- Without additional charge
- ✓ With additional charge
- Not possible

Order other voltages with voltage code **9** in the penultimate position and the corresponding order code (see "Special versions" in the "Selection and ordering data" under "Voltages").

Order other types of construction with type of construction code **9** in the final position and the corresponding order code (see "Special versions" in the "Selection and ordering data" under "Types of construction").

For footnotes, see Page 2/51 bottom.

# IEC Squirrel-Cage Motors

## Standard motors up to frame size 315 L

Self-ventilated energy-saving motors with high efficiency – Cast-iron series 1LG6

### Selection and ordering data (continued)

Order No.	Locked-rotor torque with direct starting torque	Locked-rotor current as multiple of rated current	Breakdown torque torque	Torque class	Moment of inertia	Noise at rated output	
	$T_{LR}/T_{rated}$	$I_{LR}/I_{rated}$	$T_B/T_{rated}$	CL	$J$ kgm <sup>2</sup>	Measuring surface sound pressure level at 50 Hz $L_{pFA}$ dB(A)	Sound pressure level at 50 Hz $L_{WA}$ dB(A)
<b>6-pole, 1000 rpm at 50 Hz, temperature class 155 (F), IP55 degree of protection, for use according to CEMEP</b>							
<b>1LG6 186-6AA□□</b>	2.4	5.5	2.5	16	0.2	56	69
<b>1LG6 206-6AA□□</b>	2.4	5.6	2.4	16	0.29	59	72
<b>1LG6 207-6AA□□</b>	2.4	5.6	2.4	16	0.36	59	72
<b>1LG6 223-6AA□□</b>	2.8	6.5	2.9	16	0.63	59	72
<b>1LG6 253-6AA□□</b>	2.9	6.8	2.5	16	0.93	59	72
<b>1LG6 280-6AA□□</b>	3	6.8	2.7	16	1.4	58	71
<b>1LG6 283-6AA□□</b>	3.3	7.3	2.9	16	1.6	58	71
<b>1LG6 310-6AA□□</b>	2.8	7.3	3	16	2.5	61	74
<b>1LG6 313-6AA□□</b>	2.7	7.3	2.9	16	3.2	61	74
<b>1LG6 316-6AA□□</b>	2.9	7.4	2.9	16	4	61	74
<b>1LG6 317-6AA□□</b>	3.1	7.8	3.1	16	4.7	61	74
<b>1LG6 318-6AA□□</b>	3.2	7.8	3.1	16	5.4	64	77
<b>8-pole, 750 rpm at 50 Hz, temperature class 155 (F), IP55 degree of protection, for use according to CEMEP</b>							
<b>1LG6 186-8AB□□</b>	1.7	4.6	2.2	13	0.21	62	75
<b>1LG6 207-8AB□□</b>	2.3	5.3	2.6	13	0.37	62	75
<b>1LG6 220-8AB□□</b>	2.3	5.6	2.6	13	0.55	54	67
<b>1LG6 223-8AB□□</b>	2.4	5.8	2.8	13	0.66	58	71
<b>1LG6 253-8AB□□</b>	2.5	6	2.8	13	1.1	57	70
<b>1LG6 280-8AB□□</b>	2.3	5.7	2.3	13	1.4	58	71
<b>1LG6 283-8AB□□</b>	2.6	6.1	2.5	13	1.6	58	71
<b>1LG6 310-8AB□□</b>	2.5	6.3	2.9	13	2.5	61	75
<b>1LG6 313-8AB□□</b>	2.5	6.7	2.9	13	3.1	60	74
<b>1LG6 316-8AB□□</b>	2.4	6.3	2.8	13	3.9	64	77
<b>1LG6 317-8AB□□</b>	2.4	6.4	2.6	13	4.5	64	77
<b>1LG6 318-8AB□□</b>	2.5	6.7	2.9	13	5.3	64	77

The motors can also be used for 60 Hz according to EPACT, see Pages 2/52 to 2/57.

- 1) For connection to 230 V, parallel supply cables are necessary (see catalog part 0 "Introduction", "Connection, circuit and connection box").
- 2) For connection to 400 V, parallel supply cables are necessary (see catalog part 0 "Introduction", "Connection, circuit and connection box").
- 3) If motors 1LG6 183-... to 1LG6 318-... (motor series 1LG6 frame sizes 180 M to 315 L) in types of construction with feet IM B6, IM B7, IM V6 or IM V5 without protective cover are fixed to the wall, it is recommended that the motor feet are supported.
- 4) 1LG6 220-... to 1LG6 318-... motors (motor series 1LG6 frame sizes 225 S to 315 L) are supplied with two screw-in eyebolts in accordance with IM B5, whereby one can be rotated in accordance with IM V1 or IM V3. It is important to note that stress must not be applied perpendicular to the ring plane.
- 5) Type of construction IM V3 is only possible using type of construction code **9** and order code **M1G**.
- 6) The "Second shaft extension" option, order code **K16** is not possible.
- 7) Type of construction IM V6 and IM V5 without protective cover is only possible using type of construction code **9** and order code **M1E** or **M1D**.

# IEC Squirrel-Cage Motors

## Standard motors up to frame size 315 L

Self-ventilated energy-saving motors with high efficiency – Cast-iron series 1LG6

### Selection and ordering data (continued)

Rated output at 60 Hz	Frame size	Operating values at rated output						Order No.	Price	Weight IM B3 type of construction approx. m kg
		Rated speed at 60 Hz	Rated torque at 60 Hz	EPACT with CC No. CC 032A	Nominal efficiency at 60 Hz	Power factor at 60 Hz 4/4-load	Rated current at 460 V, 60 Hz			
$P_{\text{rated}}$ HP	FS	$n_{\text{rated}}$ rpm	$T_{\text{rated}}$ Nm		$\eta_{\text{rated}}$ %	$\cos\phi_{\text{rated}}$	$I_{\text{rated}}$ A	For Order No. supplements for voltage and type of construction, see table below		
<b>2-pole, 3600 rpm at 60 Hz, temperature class 155 (F), IP55 degree of protection, for use in the North American market according to EPACT</b>										
30	180 M	3560	60	Yes	93	0.88	34	<b>1LG6 183-2AAQQ</b>		180
40	200 L	3565	80	Yes	91.7	0.88	46	<b>1LG6 206-2AAQQ</b>		225
50	200 L	3565	100	Yes	92.4	0.89	57	<b>1LG6 207-2AAQQ</b>		255
60	225 M	3570	120	Yes	93.6	0.89	67	<b>1LG6 223-2AAQQ</b>		330
75	225 M	3570	150	Yes	94.5	0.9	83	<b>1LG6 228-2AAQQ</b> <sup>1)</sup>		390
75	250 M	3578	149	No	93.6	0.89	84	<b>1LG6 253-2AAQQ</b>		420
100	250 M	3580	199	Yes	94.1	0.89	112	<b>1LG6 258-2AAQQ</b> <sup>1)</sup>		470
100	280 S	3580	199	No	95	0.89	110	<b>1LG6 280-2ABQQ</b>		530
125	280 M	3580	249	Yes	95	0.9	136	<b>1LG6 283-2ABQQ</b>		615
150	280 M	3580	299	Yes	95	0.9	164	<b>1LG6 288-2AAQQ</b> <sup>1)</sup>		660
150	315 S	3585	298	Yes	94.5	0.91	164	<b>1LG6 310-2ABQQ</b>		790
175	315 M	3586	348	Yes	95	0.91	190	<b>1LG6 313-2ABQQ</b>		915
200	315 L	3588	397	Yes	95.4	0.91	215	<b>1LG6 316-2ABQQ</b>		1055
250	315 L	3588	496	No	95.4	0.93	265	<b>1LG6 317-2ABQQ</b>		1245
300	315 L	3591	595	No	95.4	0.92	320	<b>1LG6 318-2AAQQ</b> <sup>1)</sup>		1330

### Order No. supplements

Motor type	Penultimate position: Voltage code		Final position: Type of construction							
	60 Hz		Without flange	With flange			With standard flange		With special flange	
	460 VY	460 VA (see "Introduction" for outputs at 60 Hz)	IM B3/6/7/8, IM V6, IM V5 without protective cover <sup>2)</sup>	IM B5, IM V1 without protective cover <sup>3)4)</sup>	IM V1 without protective cover <sup>3)5)</sup>	IM V1 with protective cover <sup>3)5)</sup>	IM B35	IM B14, IM V19, IM V18 without protective cover	IM B34	IM B14, IM V19, IM V18 without protective cover
	<b>1</b>	<b>6</b>	<b>0</b>	<b>1</b>	<b>8</b>	<b>4</b>	<b>6</b>	<b>2</b>	<b>7</b>	<b>3</b>
<b>1LG6 18 - . . . QQ</b>	○	○	□	✓	–	✓	✓	–	–	–
<b>1LG6 20 - . . . QQ</b>	○	○	□	✓	–	✓	✓	–	–	–
<b>1LG6 22 - . . . QQ</b>	○	○	□	✓	–	✓	✓	–	–	–
<b>1LG6 25 - . . . QQ</b>	○	○	□	✓	–	✓	✓	–	–	–
<b>1LG6 28 - . . . QQ</b>	○	○	□	✓	–	✓	✓	–	–	–
<b>1LG6 310 - . . . QQ</b>	○	○	□	✓	–	✓	✓	–	–	–
<b>1LG6 313 - . . . QQ</b>	○	○	□	✓	–	✓	✓	–	–	–
<b>1LG6 316 - . . . QQ</b>	–	○	□ <sup>6)</sup>	–	✓ <sup>7)</sup>	✓ <sup>7)</sup>	✓	–	–	–
<b>1LG6 317 - . . . QQ</b>	–	○	□ <sup>6)</sup>	–	✓ <sup>7)</sup>	✓ <sup>7)</sup>	✓	–	–	–
<b>1LG6 318 - . . . QQ</b>	–	○	□ <sup>6)</sup>	–	✓ <sup>7)</sup>	✓ <sup>7)</sup>	✓	–	–	–

- Standard version
- Without additional charge
- ✓ With additional charge
- Not possible

Order other voltages with voltage code **9** in the penultimate position and the corresponding order code (see "Special versions" in the "Selection and ordering data" under "Voltages").

Order other types of construction with type of construction code **9** in the final position and the corresponding order code (see "Special versions" in the "Selection and ordering data" under "Types of construction").

- 1) Only 60 Hz data according to EPACT on the rating plate.
- 2) If motors 1LG6 183-... to 1LG6 318-... (motor series 1LG6 frame sizes 180 M to 315 L) in types of construction with feet IM B6, IM B7, IM V6 or IM V5 without protective cover are fixed to the wall, it is recommended that the motor feet are supported.
- 3) 1LG6 220-... to 1LG6 318-... motors (motor series 1LG6 frame sizes 225 S to 315 L) are supplied with two screw-in eyebolts in accordance with IM B5, whereby one can be rotated in accordance with IM V1 or IM V3. It is important to note that stress must not be applied perpendicular to the ring plane.

- 4) Type of construction IM V3 is only possible using type of construction code **9** and order code **M1G**.
- 5) The "Second shaft extension" option, order code **K16** is not possible.
- 6) Type of construction IM V6 and IM V5 without protective cover is only possible using type of construction code **9** and order code **M1E** or **M1D**.
- 7) 2-pole motors in 60 Hz version available on request.

# IEC Squirrel-Cage Motors

## Standard motors up to frame size 315 L

Self-ventilated energy-saving motors with high efficiency – Cast-iron series 1LG6

### Selection and ordering data (continued)

Order No.	Locked-rotor torque with direct starting torque	Locked-rotor current as multiple of rated current	Breakdown torque torque	Torque class	Moment of inertia	Noise at rated output	
	$T_{LR}/T_{rated}$	$I_{LR}/I_{rated}$	$T_B/T_{rated}$	CL	$J$ kgm <sup>2</sup>	Measuring surface sound pressure level at 60 Hz $L_{p(A)}$ dB(A)	Sound pressure level at 60 Hz $L_{WA}$ dB(A)
<b>2-pole, 3600 rpm at 60 Hz, temperature class 155 (F), IP55 degree of protection, for use in the North American market according to EPACT</b>							
<b>1LG6 183-2AA□□</b>	2.7	7.9	3.7	16	0.086	72	85
<b>1LG6 206-2AA□□</b>	2.7	7.8	3.7	16	0.15	75	88
<b>1LG6 207-2AA□□</b>	2.8	7.8	3.7	16	0.18	75	88
<b>1LG6 223-2AA□□</b>	2.8	8.3	3.6	16	0.27	74	87
<b>1LG6 228-2AA□□</b>	3.3	8.7	3.7	16	0.32	74	87
<b>1LG6 253-2AA□□</b>	2.7	7.5	3.2	16	0.47	75	88
<b>1LG6 258-2AA□□</b>	2.8	8.4	3.5	16	0.57	79	92
<b>1LG6 280-2AB□□</b>	2.8	7.9	3.4	13	0.83	77	90
<b>1LG6 283-2AB□□</b>	2.9	8.3	3.4	13	1	77	90
<b>1LG6 288-2AA□□</b>	3.1	8.5	3.6	16	1.16	77	90
<b>1LG6 310-2AB□□</b>	2.6	7.5	3.1	13	1.4	81	94
<b>1LG6 313-2AB□□</b>	3	8.3	3.3	13	1.6	81	94
<b>1LG6 316-2AB□□</b>	3	8.4	3.5	13	2.1	81	94
<b>1LG6 317-2AB□□</b>	3.2	8.6	3.4	13	2.5	81	94
<b>1LG6 318-2AA□□</b>	4.1	10	3.9	16	2.74	83	96

The motors can also be used for 50 Hz according to CEMEP, see Pages 2/48 to 2/51.

# IEC Squirrel-Cage Motors

## Standard motors up to frame size 315 L

Self-ventilated energy-saving motors with high efficiency – Cast-iron series 1LG6

### Selection and ordering data (continued)

Rated output at 60 Hz	Frame size	Operating values at rated output					Power factor at 60 Hz 4/4-load	Rated current at 460 V, 60 Hz	Order No.	Price	Weight IM B3 type of construction approx. m kg
		Rated speed at 60 Hz	Rated torque at 60 Hz	EPACT with CC No. CC 032A	Nominal efficiency at 60 Hz	EPACT with CC No. CC 032A					
$P_{\text{rated}}$ HP	FS	$n_{\text{rated}}$ rpm	$T_{\text{rated}}$ Nm	$\eta_{\text{rated}}$ %	$\cos\phi_{\text{rated}}$	$I_{\text{rated}}$ A					
<b>4-pole, 1800 rpm at 60 Hz, temperature class 155 (F), IP55 degree of protection, for use in the North American market according to EPACT</b>											
25	180 M	1775	100	Yes	92.4	0.82	31	<b>1LG6 183-4AAQQ</b>		155	
30	180 L	1775	120	Yes	92.4	0.83	36.5	<b>1LG6 186-4AAQQ</b>		180	
40	200 L	1775	160	Yes	93	0.84	48	<b>1LG6 207-4AAQQ</b>		225	
50	225 S	1785	199	No	93.6	0.84	60	<b>1LG6 220-4AAQQ</b>		290	
60	225 M	1785	239	Yes	94.1	0.85	70	<b>1LG6 223-4AAQQ</b>		330	
75	225 M	1785	299	Yes	94.1	0.85	88	<b>1LG6 228-4AAQQ</b> <sup>1)</sup>		355	
75	250 M	1790	298	No	94.5	0.86	86	<b>1LG6 253-4AAQQ</b>		460	
100	250 M	1788	398	Yes	94.5	0.86	116	<b>1LG6 258-4AAQQ</b> <sup>1)</sup>		495	
100	280 S	1788	398	No	94.5	0.86	114	<b>1LG6 280-4AAQQ</b>		575	
125	280 M	1790	497	Yes	95	0.86	144	<b>1LG6 283-4AAQQ</b>		675	
150	280 M	1788	598	Yes	95	0.86	172	<b>1LG6 288-4AAQQ</b> <sup>1)</sup>		710	
150	315 S	1791	596	Yes	95	0.87	170	<b>1LG6 310-4AAQQ</b>		810	
175	315 M	1791	696	Yes	95.4	0.87	198	<b>1LG6 313-4AAQQ</b>		965	
200	315 L	1792	795	Yes	95.4	0.87	225	<b>1LG6 316-4AAQQ</b>		1105	
250	315 L	1792	994	No	95.8	0.87	280	<b>1LG6 317-4AAQQ</b>		1305	
300	315 L	1792	1193	No	95.8	0.87	335	<b>1LG6 318-4AAQQ</b> <sup>1)</sup>		1345	

### Order No. supplements

Motor type	Penultimate position: Voltage code		Final position: Type of construction code							
	60 Hz		Without flange	With flange			With standard flange		With special flange	
	460 VY	460 VΔ (see "Introduction" for outputs at 60 Hz)	IM B3/6/7/8, IM V6, IM V5 without protective cover <sup>2)</sup>	IM B5, IM V1 without protective cover <sup>3)4)</sup>	IM V1 without protective cover <sup>3)</sup>	IM V1 with protective cover <sup>3)5)</sup>	IM B35	IM B14, IM V19, IM V18 without protective cover	IM B34	IM B14, IM V19, IM V18 without protective cover
	<b>1</b>	<b>6</b>	<b>0</b>	<b>1</b>	<b>8</b>	<b>4</b>	<b>6</b>	<b>2</b>	<b>7</b>	<b>3</b>
<b>1LG6 18</b> - . . . . □□	○	○	□	✓	–	✓	✓	–	–	–
<b>1LG6 20</b> - . . . . □□	○	○	□	✓	–	✓	✓	–	–	–
<b>1LG6 22</b> - . . . . □□	○	○	□	✓	–	✓	✓	–	–	–
<b>1LG6 25</b> - . . . . □□	○	○	□	✓	–	✓	✓	–	–	–
<b>1LG6 28</b> - . . . . □□	○	○	□	✓	–	✓	✓	–	–	–
<b>1LG6 310</b> - . . . . □□	○	○	□	✓	–	✓	✓	–	–	–
<b>1LG6 313</b> - . . . . □□	○	○	□	✓	–	✓	✓	–	–	–
<b>1LG6 316</b> - . . . . □□	–	○	□ <sup>6)</sup>	–	✓	✓	✓	–	–	–
<b>1LG6 317</b> - . . . . □□	–	○	□ <sup>6)</sup>	–	✓	✓	✓	–	–	–
<b>1LG6 318</b> - . . . . □□	–	○	□ <sup>6)</sup>	–	✓	✓	✓	–	–	–

- Standard version
- Without additional charge
- ✓ With additional charge
- Not possible

Order other voltages with voltage code **9** in the penultimate position and the corresponding order code (see "Special versions" in the "Selection and ordering data" under "Voltages").

Order other types of construction with type of construction code **9** in the final position and the corresponding order code (see "Special versions" in the "Selection and ordering data" under "Types of construction").

- 1) Only 60 Hz data according to EPACT on the rating plate.
- 2) If motors 1LG6 183-... to 1LG6 318-... (motor series 1LG6 frame sizes 180 M to 315 L) in types of construction with feet IM B6, IM B7, IM V6 or IM V5 without protective cover are fixed to the wall, it is recommended that the motor feet are supported.
- 3) 1LG6 220-... to 1LG6 318-... motors (motor series 1LG6 frame sizes 225 S to 315 L) are supplied with two screw-in eyebolts in accordance with IM B5, whereby one can be rotated in accordance with IM V1 or IM V3. It is important to note that stress must not be applied perpendicular to the ring plane.

- 4) Type of construction IM V3 is only possible using type of construction code **9** and order code **M1G**.
- 5) The "Second shaft extension" option, order code **K16** is not possible.
- 6) Type of construction IM V6 and IM V5 without protective cover is only possible using type of construction code **9** and order code **M1E** or **M1D**.



# IEC Squirrel-Cage Motors

## Standard motors up to frame size 315 L

Self-ventilated energy-saving motors with high efficiency – Cast-iron series 1LG6

### Selection and ordering data (continued)

Order No.	Locked-rotor torque with direct starting torque	Locked-rotor current as multiple of rated current	Breakdown torque torque	Torque class	Moment of inertia	Noise at rated output	
	$T_{LR}/T_{rated}$	$I_{LR}/I_{rated}$	$T_B/T_{rated}$	CL	$J$ kgm <sup>2</sup>	Measuring surface sound pressure level at 60 Hz $L_{pFA}$ dB(A)	Sound pressure level at 60 Hz $L_{WA}$ dB(A)
<b>4-pole, 1800 rpm at 60 Hz, temperature class 155 (F), IP55 degree of protection, for use in the North American market according to EPACT</b>							
<b>1LG6 183-4AA□□</b>	2.9	7.1	3.3	16	0.12	65	78
<b>1LG6 186-4AA□□</b>	2.8	7.4	3.4	16	0.14	65	78
<b>1LG6 207-4AA□□</b>	3	7.7	3.7	16	0.23	66	79
<b>1LG6 220-4AA□□</b>	3.1	7.5	3.4	16	0.4	65	78
<b>1LG6 223-4AA□□</b>	3.3	7.9	3.5	16	0.49	65	78
<b>1LG6 228-4AA□□</b>	3	7.8	3.3	16	0.66	64	78
<b>1LG6 253-4AA□□</b>	2.9	8.2	3.4	16	0.86	68	81
<b>1LG6 258-4AA□□</b>	3	8.1	3.3	16	0.99	72	86
<b>1LG6 280-4AA□□</b>	2.9	7.6	3.2	16	1.4	71	84
<b>1LG6 283-4AA□□</b>	3	8.2	3.4	16	1.7	71	84
<b>1LG6 288-4AA□□</b>	3.1	8.4	3.5	16	1.88	71	85
<b>1LG6 310-4AA□□</b>	3.1	7.8	3.2	16	2.3	75	88
<b>1LG6 313-4AA□□</b>	3.2	8.4	3.3	16	2.9	75	88
<b>1LG6 316-4AA□□</b>	3.7	9	3.6	16	3.5	75	88
<b>1LG6 317-4AA□□</b>	4	9.1	3.7	16	4.2	75	88
<b>1LG6 318-4AA□□</b>	4	9.3	3.7	16	4.5	81	94

The motors can also be used for 50 Hz according to CEMEP, see Pages 2/48 to 2/51.

# IEC Squirrel-Cage Motors

## Standard motors up to frame size 315 L

Self-ventilated energy-saving motors with high efficiency – Cast-iron series 1LG6

### Selection and ordering data (continued)

Rated output at 60 Hz	Frame size	Operating values at rated output					Power factor at 60 Hz 4/4-load	Rated current at 460 V, 60 Hz	Order No. For Order No. supplements for voltage and type of construction, see table below	Price	Weight IM B3 type of construction approx. <i>m</i> kg
		Rated speed at 60 Hz	Rated torque at 60 Hz	EPACT with CC No. CC 032A	Nominal efficiency at 60 Hz	EPACT with CC No. CC 032A					
$P_{\text{rated}}$ HP	FS	$n_{\text{rated}}$ rpm	$T_{\text{rated}}$ Nm		$\eta_{\text{rated}}$ %	$\cos\phi_{\text{rated}}$	$I_{\text{rated}}$ A				
<b>6-pole, 1200 rpm at 60 Hz, temperature class 155 (F), IP55 degree of protection, for use in the North American market according to EPACT</b>											
20	180 L	1178	121	Yes	91	0.8	25.5	<b>1LG6 186-6AA□□</b>		175	
25	200 L	1180	151	Yes	91.7	0.79	32.5	<b>1LG6 206-6AA□□</b>		210	
30	200 L	1180	181	Yes	91.7	0.8	38.5	<b>1LG6 207-6AA□□</b>		240	
40	225 M	1184	241	Yes	93	0.82	49	<b>1LG6 223-6AA□□</b>		325	
50	225 M	1184	301	Yes	93	0.83	61	<b>1LG6 228-6AA□□</b> <sup>1)</sup>		355	
50	250 M	1186	300	No	93	0.82	61	<b>1LG6 253-6AA□□</b>		405	
60	250 M	1186	361	Yes	93.6	0.82	73	<b>1LG6 258-6AA□□</b> <sup>1)</sup>		435	
60	280 S	1190	359	No	94.1	0.83	72	<b>1LG6 280-6AA□□</b>		520	
75	280 M	1190	449	No	94.5	0.83	89	<b>1LG6 283-6AA□□</b>		570	
100	280 M	1190	599	Yes	94.5	0.84	118	<b>1LG6 288-6AA□□</b> <sup>1)</sup>		615	
100	315 S	1191	598	Yes	94.5	0.82	120	<b>1LG6 310-6AA□□</b>		760	
125	315 M	1191	747	Yes	94.5	0.84	148	<b>1LG6 313-6AA□□</b>		935	
150	315 L	1192	896	Yes	95	0.84	176	<b>1LG6 316-6AA□□</b>		1010	
175	315 L	1192	1046	Yes	95	0.84	205	<b>1LG6 317-6AA□□</b>		1180	
200	315 L	1192	1195	Yes	95.4	0.84	235	<b>1LG6 318-6AA□□</b>		1245	

### Order No. supplements

Motor type	Penultimate position: Voltage code		Final position: Type of construction code							
	60 Hz		Without flange	With flange			With standard flange		With special flange	
	460 VY (see "Introduction" for outputs at 60 Hz)	460 VA	IM B3/6/7/8, IM V6, IM V5 without protective cover <sup>2)</sup>	IM B5, IM V1 without protective cover <sup>3) 4)</sup>	IM V1 without protective cover <sup>3) 5)</sup>	IM V1 with protective cover <sup>3) 5)</sup>	IM B35	IM B14, IM V19, IM V18 without protective cover	IM B34	IM B14, IM V19, IM V18 without protective cover
	<b>1</b>	<b>6</b>	<b>0</b>	<b>1</b>	<b>8</b>	<b>4</b>	<b>6</b>	<b>2</b>	<b>7</b>	<b>3</b>
<b>1LG6 18 - . . . . □□</b>	○	○	□	✓	–	✓	✓	–	–	–
<b>1LG6 20 - . . . . □□</b>	○	○	□	✓	–	✓	✓	–	–	–
<b>1LG6 22 - . . . . □□</b>	○	○	□	✓	–	✓	✓	–	–	–
<b>1LG6 25 - . . . . □□</b>	○	○	□	✓	–	✓	✓	–	–	–
<b>1LG6 28 - . . . . □□</b>	○	○	□	✓	–	✓	✓	–	–	–
<b>1LG6 310 - . . . . □□</b>	○	○	□	✓	–	✓	✓	–	–	–
<b>1LG6 313 - . . . . □□</b>	○	○	□	✓	–	✓	✓	–	–	–
<b>1LG6 316 - . . . . □□</b>	–	○	□ <sup>6)</sup>	–	✓	✓	✓	–	–	–
<b>1LG6 317 - . . . . □□</b>	–	○	□ <sup>6)</sup>	–	✓	✓	✓	–	–	–
<b>1LG6 318 - . . . . □□</b>	–	○	□ <sup>6)</sup>	–	✓	✓	✓	–	–	–

- Standard version
- Without additional charge
- ✓ With additional charge
- Not possible

Order other voltages with voltage code **9** in the penultimate position and the corresponding order code (see "Special versions" in the "Selection and ordering data" under "Voltages").

Order other types of construction with type of construction code **9** in the final position and the corresponding order code (see "Special versions" in the "Selection and ordering data" under "Types of construction").

- 1) Only 60 Hz data according to EPACT on the rating plate.
- 2) If motors 1LG6 183-... to 1LG6 318-... (motor series 1LG6 frame sizes 180 M to 315 L) in types of construction with feet IM B6, IM B7, IM V6 or IM V5 without protective cover are fixed to the wall, it is recommended that the motor feet are supported.
- 3) 1LG6 220-... to 1LG6 318-... motors (motor series 1LG6 frame sizes 225 S to 315 L) are supplied with two screw-in eyebolts in accordance with IM B5, whereby one can be rotated in accordance with IM V1 or IM V3. It is important to note that stress must not be applied perpendicular to the ring plane.

- 4) Type of construction IM V3 is only possible using type of construction code **9** and order code **M1G**.
- 5) The "Second shaft extension" option, order code **K16** is not possible.
- 6) Type of construction IM V6 and IM V5 without protective cover is only possible using type of construction code **9** and order code **M1E** or **M1D**.

# IEC Squirrel-Cage Motors

## Standard motors up to frame size 315 L

Self-ventilated energy-saving motors with high efficiency – Cast-iron series 1LG6

### Selection and ordering data (continued)

Order No.	Locked-rotor torque with direct starting torque	Locked-rotor current as multiple of rated current	Breakdown torque torque	Torque class	Moment of inertia	Noise at rated output	
	$T_{LR}/T_{rated}$	$I_{LR}/I_{rated}$	$T_B/T_{rated}$	CL	$J$ kgm <sup>2</sup>	Measuring surface sound pressure level at 60 Hz $L_{p(A)}$ dB(A)	Sound pressure level at 60 Hz $L_{WA}$ dB(A)
<b>6-pole, 1200 rpm at 60 Hz, temperature class 155 (F), IP55 degree of protection, for use in the North American market according to EPACT</b>							
<b>1LG6 186-6AA□□</b>	2.9	6.5	3	16	0.2	57	70
<b>1LG6 206-6AA□□</b>	2.9	6.5	2.7	16	0.29	65	78
<b>1LG6 207-6AA□□</b>	2.9	6.4	2.7	16	0.36	65	78
<b>1LG6 223-6AA□□</b>	3.4	7.2	3.4	16	0.63	62	75
<b>1LG6 228-6AA□□</b>	3.2	7.6	3.4	16	0.76	61	74
<b>1LG6 253-6AA□□</b>	3.4	7.4	2.9	16	0.93	63	76
<b>1LG6 258-6AA□□</b>	3.4	7.4	2.9	16	1.07	65	79
<b>1LG6 280-6AA□□</b>	3.6	7.7	3.1	16	1.4	62	75
<b>1LG6 283-6AA□□</b>	3.9	8.3	3.3	16	1.6	62	75
<b>1LG6 288-6AA□□</b>	4	8.4	3.3	16	1.94	64	78
<b>1LG6 310-6AA□□</b>	3.3	8.4	3.4	16	2.5	66	79
<b>1LG6 313-6AA□□</b>	3	7.9	3.1	16	3.2	66	79
<b>1LG6 316-6AA□□</b>	3.3	8.5	3.3	16	4	66	79
<b>1LG6 317-6AA□□</b>	3.6	8.9	3.6	16	4.7	66	79
<b>1LG6 318-6AA□□</b>	4	9.4	4	16	5.4	69	82

The motors can also be used for 50 Hz according to CEMEP, see Pages 2/48 to 2/51.

# IEC Squirrel-Cage Motors

## Standard motors up to frame size 315 L

Self-cooled motors without external fan  
Aluminum series 1LP7/1LP5

### Selection and ordering data

Rated output with		Frame size	Order No.	Price	Weight
			For Order No. supplements for voltage and type of construction, see table below		For IM B3 type of construction approx.
50 Hz $P_{rated}$ kW	60 Hz $P_{rated}$ kW	FS			$m$ kg
2-pole, 3000 rpm at 50 Hz, 3600 rpm at 60 Hz, temperature class 155 (F), used acc. to temperature class 130 (B), IP55 degree of protection, with reduced output					
0.12	0.14	63 M	1LP7 060-2AA□□		3.4
0.16	0.18	63 M	1LP7 063-2AA□□		3.9
0.19	0.22	71 M	1LP7 070-2AA□□		4.9
0.27	0.3	71 M	1LP7 073-2AA□□		6.4
0.35	0.40	80 M	1LP7 080-2AA□□		8.0
0.55	0.6	80 M	1LP7 083-2AA□□		9.6
0.82	0.95	90 S	1LP7 090-2AA□□		12.5
1.1	1.25	90 L	1LP7 096-2AA□□		15.2
1.3	1.5	100 L	▶ 1LP7 106-2AA□□		22.3
1.8	2.1	112 M	▶ 1LP7 113-2AA□□		29.0
2.5	2.9	132 S	▶ 1LP7 130-2AA□□		42.0
3.4	3.9	132 S	▶ 1LP7 131-2AA□□		51.0
5	5.7	160 M	▶ 1LP7 163-2AA□□		70.0
6	6.9	160 M	▶ 1LP7 164-2AA□□		82.0
7	8	160 L	▶ 1LP7 166-2AA□□		99.0
10	11.5	180 M	1LP5 183-2AA□□		112.0
13.5	15.5	200 L	1LP5 206-2AA□□		160.0
16.5	19	200 L	1LP5 207-2AA□□		182.0

The rated outputs and weights may change slightly after they have been checked.

Further electrical data can be calculated and supplied on receipt of order.

### Order No. supplements

Motor type	Penultimate position: Voltage code				Final position: Type of construction code							
	50 Hz		60 Hz		Without flange	With flange		With standard flange		With special flange		
	230 VΔ/400 VY	400 VΔ/690 VY	500 VY	500 VΔ	460 VY	460 VΔ	IM B3/6/7/8, IM V6, IM V5 without protective cover	IM B5, IM V1 without protective cover <sup>1)</sup>	IM B35	IM B14, IM V19, IM V18 without protective cover	IM B34	IM B14, IM V19, IM V18 without protective cover
	1	6	3	5	1	6	0	1	6	2	7	3
1LP7 06 . . . . □□	○	○	○	–	○	○	□	✓	✓	✓	✓	✓
1LP7 07 . . . . □□	○	○	○	–	○	○	□	✓	✓	✓	✓	✓
1LP7 08 . . . . □□	○	○	○	–	○	○	□	✓	✓	✓	✓	✓
1LP7 09 . . . . □□	○	○	○	–	○	○	□	✓	✓	✓	✓	✓
1LP7 10 . . . . □□	○	○	○	○	○	○	□	✓	✓	✓	✓	✓
1LP7 11 . . . . □□	○	○	○	○	○	○	□	✓	✓	✓	✓	✓
1LP7 13 . . . . □□	○	○	○	○	○	○	□	✓	✓	✓	✓	✓
1LP7 16 . . . . □□	○	○	○	○	○	○	□	✓	✓	✓	✓	✓
1LP5 18 . . . . □□	○	○	○	○	○	○	□	✓ <sup>2)</sup>	✓	–	–	–
1LP5 20 . . . . □□	○	○	○	○	○	○	□	✓ <sup>2)</sup>	✓	–	–	–

- Standard version
- Without additional charge
- ✓ With additional charge
- Not possible

▶ The Order No. for 1LP7 motors marked with this symbol are phase-out models.  
1PC1 motors are the successors.  
For additional information see catalog part 1 "New Generation 1LE1/1PC1" under "Self-cooled motors without external fan and fan cover with improved efficiency" Pages 1/46 to 1/49.

Order other voltages with voltage code **9** in the penultimate position and the corresponding order code (see "Special versions" in the "Selection and ordering data" under "Voltages").

Order other types of construction with type of construction code **9** in the final position and the corresponding order code (see "Special versions" in the "Selection and ordering data" under "Types of construction").

<sup>1)</sup> 1LP5 183-... to 1LP5 207-... motors (motor series 1LA5, frame sizes 180 M to 200 L) can be supplied with two additional eyebolts; specify supplement **-Z** and order code **K32**.

<sup>2)</sup> Type of construction IM V3 is only possible using type of construction code **9** and order code **M1G**.

# IEC Squirrel-Cage Motors

## Standard motors up to frame size 315 L

Self-cooled motors without external fan  
Aluminum series 1LP7/1LP5

### Selection and ordering data (continued)

Rated output with		Frame size	Order No.	Price	Weight
50 Hz $P_{rated}$ kW	60 Hz $P_{rated}$ kW	FS	For Order No. supplements for voltage and type of construction, see table below		For IM B3 type of construction approx.  $m$ kg
4-pole, 1500 rpm at 50 Hz, 1800 rpm at 60 Hz, temperature class 155 (F), used acc. to temperature class 155 (F), IP55 degree of protection, with reduced output					
0.07	0.08	63 M	1LP7 060-4AB□□		3.4
0.12	0.14	63 M	1LP7 063-4AB□□		3.9
0.13	0.15	71 M	1LP7 070-4AB□□		4.7
0.19	0.22	71 M	1LP7 073-4AB□□		5.8
0.22	0.25	80 M	1LP7 080-4AA□□		7.8
0.38	0.45	80 M	1LP7 083-4AA□□		9.1
0.55	0.63	90 S	1LP7 090-4AA□□		11.9
0.65	0.75	90 L	1LP7 096-4AA□□		15.1
0.88	1.00	100 L	▶ 1LP7 106-4AA□□		23.0
1.2	1.4	100 L	▶ 1LP7 107-4AA□□		25.0
1.6	1.85	112 M	▶ 1LP7 113-4AA□□		30.0
2.5	2.9	132 S	▶ 1LP7 130-4AA□□		44.0
3.1	3.6	132 M	▶ 1LP7 133-4AA□□		54.0
4.8	5.5	160 M	▶ 1LP7 163-4AA□□		74.0
5.4	6.2	160 L	▶ 1LP7 166-4AA□□		90.0
7.5	8.5	180 M	1LP5 183-4AA□□		109.0
9	10.5	180 L	1LP5 186-4AA□□		122.0
12	14	200 L	1LP5 207-4AA□□		165.0

The rated outputs and weights may change slightly after they have been checked.

Further electrical data can be calculated and supplied on receipt of order.

### Order No. supplements

Motor type	Penultimate position: Voltage code				Final position: Type of construction code							
	50 Hz		60 Hz		Without flange	With flange	With standard flange	With special flange				
	230 VΔ/400 VY	400 VΔ/690 VY	500 VY	500 VΔ	460 VY	460 VΔ (see "Introduction" for outputs at 60 Hz)	IM B3/6/7/8, IM V6, IM V5 without protective cover	IM B5, IM V1 without protective cover <sup>1)</sup> IM V3	IM B35	IM B14, IM V19, IM V18 without protective cover	IM B34	IM B14, IM V19, IM V18 without protective cover
	1	6	3	5	1	6	0	1	6	2	7	3
1LP7 06 . . . . □□	○	○	○	–	○	○	□	✓	✓	✓	✓	✓
1LP7 07 . . . . □□	○	○	○	–	○	○	□	✓	✓	✓	✓	✓
1LP7 08 . . . . □□	○	○	○	–	○	○	□	✓	✓	✓	✓	✓
1LP7 09 . . . . □□	○	○	○	–	○	○	□	✓	✓	✓	✓	✓
1LP7 10 . . . . □□	○	○	○	○	○	○	□	✓	✓	✓	✓	✓
1LP7 11 . . . . □□	○	○	○	○	○	○	□	✓	✓	✓	✓	✓
1LP7 13 . . . . □□	○	○	○	○	○	○	□	✓	✓	✓	✓	✓
1LP7 16 . . . . □□	○	○	○	○	○	○	□	✓	✓	✓	✓	✓
1LP5 18 . . . . □□	○	○	○	○	○	○	□	✓ <sup>2)</sup>	✓	–	–	–
1LP5 20 . . . . □□	○	○	○	○	○	○	□	✓ <sup>2)</sup>	✓	–	–	–

- Standard version
- Without additional charge
- ✓ With additional charge
- Not possible

▶ The Order No. for 1LP7 motors marked with this symbol are phase-out models.  
1PC1 motors are the successors.  
For additional information see catalog part 1 "New Generation 1LE1/1PC1" under "Self-cooled motors without external fan and fan cover with improved efficiency" Pages 1/46 to 1/49.

Order other voltages with voltage code **9** in the penultimate position and the corresponding order code (see "Special versions" in the "Selection and ordering data" under "Voltages").

Order other types of construction with type of construction code **9** in the final position and the corresponding order code (see "Special versions" in the "Selection and ordering data" under "Types of construction").

<sup>1)</sup> 1LP5 183-... to 1LP5 207-... motors (motor series 1LA5, frame sizes 180 M to 200 L) can be supplied with two additional eyebolts; specify supplement **-Z** and order code **K32**.

<sup>2)</sup> Type of construction IM V3 is only possible using type of construction code **9** and order code **M1G**.

# IEC Squirrel-Cage Motors

## Standard motors up to frame size 315 L

Self-cooled motors without external fan  
Aluminum series 1LP7/1LP5

### Selection and ordering data (continued)

Rated output with		Frame size	Order No.	Price	Weight
50 Hz $P_{rated}$ kW	60 Hz $P_{rated}$ kW	FS	For Order No. supplements for voltage and type of construction, see table below  ▶ Phase-out model		For IM B3 type of construction approx.  $m$ kg
<b>6-pole, 1000 rpm at 50 Hz, 1200 rpm at 60 Hz, temperature class 155 (F), used acc. to temperature class 155 (F), IP55 degree of protection, with reduced output</b>					
0.045	0.05	63 M	<b>1LP7 063-6AA□□</b>		4.0
0.09	0.105	71 M	<b>1LP7 070-6AA□□</b>		6.1
0.13	0.15	71 M	<b>1LP7 073-6AA□□</b>		6.1
0.18	0.2	80 M	<b>1LP7 080-6AA□□</b>		7.3
0.27	0.3	80 M	<b>1LP7 083-6AA□□</b>		9.1
0.37	0.4	90 S	<b>1LP7 090-6AA□□</b>		12.1
0.5	0.57	90 L	<b>1LP7 096-6AA□□</b>		15.2
0.7	0.8	100 L	▶ 1LP7 106-6AA□□		23.3
1.0	1.15	112 M	▶ 1LP7 113-6AA□□		26.0
1.7	1.9	132 S	▶ 1LP7 130-6AA□□		40.0
2	2.3	132 M	▶ 1LP7 133-6AA□□		45.0
2.3	2.65	132 M	▶ 1LP7 134-6AA□□		52.0
3.3	3.8	160 M	▶ 1LP7 163-6AA□□		74.0
4	4.6	160 L	▶ 1LP7 166-6AA□□		99.0
6.5	7.5	180 L	<b>1LP5 186-6AA□□</b>		122.0
8.5	10	200 L	<b>1LP5 207-6AA□□</b>		165.0

The rated outputs and weights may change slightly after they have been checked.

Further electrical data can be calculated and supplied on receipt of order.

### Order No. supplements

Motor type	Penultimate position: Voltage code				60 Hz		Final position: Type of construction code					
	50 Hz		60 Hz		Without flange	With flange	With standard flange		With special flange			
	230 VΔ/400 VY	400 VΔ/690 VY	500 VY	500 VΔ	460 VY	460 VΔ	IM B3/6/7/8, IM V6, IM V5 without protective cover	IM B5, IM V1 without protective cover <sup>1)</sup>	IM B35	IM B14, IM V19, IM V18 without protective cover	IM B34	IM B14, IM V19, IM V18 without protective cover
	<b>1</b>	<b>6</b>	<b>3</b>	<b>5</b>	<b>1</b>	<b>6</b>	<b>0</b>	<b>1</b>	<b>6</b>	<b>2</b>	<b>7</b>	<b>3</b>
<b>1LP7 06</b> . . . . □□	○	○	○	–	○	○	□	✓	✓	✓	✓	✓
<b>1LP7 07</b> . . . . □□	○	○	○	–	○	○	□	✓	✓	✓	✓	✓
<b>1LP7 08</b> . . . . □□	○	○	○	–	○	○	□	✓	✓	✓	✓	✓
<b>1LP7 09</b> . . . . □□	○	○	○	–	○	○	□	✓	✓	✓	✓	✓
1LP7 10 . . . . □□	○	○	○	○	○	○	□	✓	✓	✓	✓	✓
1LP7 11 . . . . □□	○	○	○	○	○	○	□	✓	✓	✓	✓	✓
1LP7 13 . . . . □□	○	○	○	○	○	○	□	✓	✓	✓	✓	✓
1LP7 16 . . . . □□	○	○	○	○	○	○	□	✓	✓	✓	✓	✓
<b>1LP5 18</b> . . . . □□	○	○	○	○	○	○	□	✓ <sup>2)</sup>	✓	–	–	–
<b>1LP5 20</b> . . . . □□	○	○	○	○	○	○	□	✓ <sup>2)</sup>	✓	–	–	–

- Standard version
- Without additional charge
- ✓ With additional charge
- Not possible

▶ The Order No. for 1LP7 motors marked with this symbol are phase-out models.

1PC1 motors are the successors.

For additional information see catalog part 1 "New Generation 1LE1/1PC1" under "Self-cooled motors without external fan and fan cover with improved efficiency" Pages 1/46 to 1/49.

Order other voltages with voltage code **9** in the penultimate position and the corresponding order code (see "Special versions" in the "Selection and ordering data" under "Voltages").

Order other types of construction with type of construction code **9** in the final position and the corresponding order code (see "Special versions" in the "Selection and ordering data" under "Types of construction").

<sup>1)</sup> 1LP5 183-... to 1LP5 207-... motors (motor series 1LA5, frame sizes 180 M to 200 L) can be supplied with two additional eyebolts; specify supplement **-Z** and order code **K32**.

<sup>2)</sup> Type of construction IM V3 is only possible using type of construction code **9** and order code **M1G**.

# IEC Squirrel-Cage Motors

## Standard motors up to frame size 315 L

Self-cooled motors without external fan  
Aluminum series 1LP7/1LP5

### Selection and ordering data (continued)

Rated output with		Frame size	Order No.	Price	Weight
50 Hz $P_{rated}$ kW	60 Hz $P_{rated}$ kW	FS	For Order No. supplements for voltage and type of construction, see table below  ▶ Phase-out model		For IM B3 type of construction approx.  $m$ kg
<b>8-pole, 750 rpm at 50 Hz, 900 rpm at 60 Hz, temperature class 155 (F), used acc. to temperature class 155 (F), IP55 degree of protection, with reduced output</b>					
0.045	0.05	71 M	<b>1LP7 070-8AB00</b>		6.1
0.06	0.07	71 M	<b>1LP7 073-8AB00</b>		6.1
0.09	0.105	80 M	<b>1LP7 080-8AB00</b>		7.3
0.13	0.15	80 M	<b>1LP7 083-8AB00</b>		9.1
0.25	0.29	90 S	<b>1LP7 090-8AB00</b>		10.2
0.35	0.4	90 L	<b>1LP7 096-8AB00</b>		12.8
0.45	0.5	100 L	▶ 1LP7 106-8AB00		19.4
0.65	0.75	100 L	▶ 1LP7 107-8AB00		21.3
0.8	0.9	112 M	▶ 1LP7 113-8AB00		23.3
1.2	1.4	132 S	▶ 1LP7 130-8AB00		40.0
1.45	1.7	132 M	▶ 1LP7 133-8AB00		48.0
1.8	2.1	160 M	▶ 1LP7 163-8AB00		59.0
2.4	2.8	160 L	▶ 1LP7 164-8AB00		68.0
3	3.45	160 L	▶ 1LP7 166-8AB00		88.0
5.5	6.5	180 L	<b>1LP5 186-8AB00</b>		122.0
7.5	9	200 L	<b>1LP5 207-8AB00</b>		180.0

The rated outputs and weights may change slightly after they have been checked.

Further electrical data can be calculated and supplied on receipt of order.

### Order No. supplements

Motor type	Penultimate position: Voltage code						Final position: Type of construction code					
	50 Hz		60 Hz				Without flange	With flange	With standard flange		With special flange	
	230 VΔ/400 VY	400 VΔ/690 VY	500 VY	500 VΔ	460 VY	460 VΔ	IM B3/6/7/8, IM V6, IM V5 without protective cover	IM B5, IM V1 without protective cover <sup>1)</sup> IM V3	IM B35	IM B14, IM V19, IM V18 without protective cover	IM B34	IM B14, IM V19, IM V18 without protective cover
	<b>1</b>	<b>6</b>	<b>3</b>	<b>5</b>	<b>1</b>	<b>6</b>	<b>0</b>	<b>1</b>	<b>6</b>	<b>2</b>	<b>7</b>	<b>3</b>
<b>1LP7 06</b> . . . . □□	○	○	○	–	○	○	□	✓	✓	✓	✓	✓
<b>1LP7 07</b> . . . . □□	○	○	○	–	○	○	□	✓	✓	✓	✓	✓
<b>1LP7 08</b> . . . . □□	○	○	○	–	○	○	□	✓	✓	✓	✓	✓
<b>1LP7 09</b> . . . . □□	○	○	○	–	○	○	□	✓	✓	✓	✓	✓
1LP7 10 . . . . □□	○	○	○	○	○	○	□	✓	✓	✓	✓	✓
1LP7 11 . . . . □□	○	○	○	○	○	○	□	✓	✓	✓	✓	✓
1LP7 13 . . . . □□	○	○	○	○	○	○	□	✓	✓	✓	✓	✓
1LP7 16 . . . . □□	○	○	○	○	○	○	□	✓	✓	✓	✓	✓
<b>1LP5 18</b> . . . . □□	○	○	○	○	○	○	□	✓ <sup>2)</sup>	✓	–	–	–
<b>1LP5 20</b> . . . . □□	○	○	○	○	○	○	□	✓ <sup>2)</sup>	✓	–	–	–

- Standard version
- Without additional charge
- ✓ With additional charge
- Not possible

▶ The Order No. for 1LP7 motors marked with this symbol are phase-out models.

1PC1 motors are the successors.

For additional information see catalog part 1 "New Generation 1LE1/1PC1" under "Self-cooled motors without external fan and fan cover with improved efficiency" Pages 1/46 to 1/49.

Order other voltages with voltage code **9** in the penultimate position and the corresponding order code (see "Special versions" in the "Selection and ordering data" under "Voltages").

Order other types of construction with type of construction code **9** in the final position and the corresponding order code (see "Special versions" in the "Selection and ordering data" under "Types of construction").

<sup>1)</sup> 1LP5 183-... to 1LP5 207-... motors (motor series 1LA5, frame sizes 180 M to 200 L) can be supplied with two additional eyebolts; specify supplement **-Z** and order code **K32**.

<sup>2)</sup> Type of construction IM V3 is only possible using type of construction code **9** and order code **M1G**.

# IEC Squirrel-Cage Motors

## Standard motors up to frame size 315 L

Self-cooled motors without external fan  
Cast-iron series 1LP4

### Selection and ordering data

Rated output at 50 Hz	Frame size	Operating values at rated output					Rated current at 50 Hz 400 V	Locked-rotor torque with direct starting torque	Locked-rotor current starting as multiple of rated current	Break-down torque	Torque class	Moment of inertia	Order No.	Price	Weight
		Rated speed at 50 Hz	Rated torque at 50 Hz	Efficiency at 50 Hz 4/4-load	Power factor at 50 Hz 4/4-load	Rated current at 50 Hz 400 V									
$P_{\text{rated}}$ kW	FS	$n_{\text{rated}}$ rpm	$T_{\text{rated}}$ Nm	$\eta_{\text{rated}}$ %	$\cos\phi_{\text{rated}}$	$I_{\text{rated}}$ A	$T_{\text{LR}}/T_{\text{rated}}$	$I_{\text{LR}}/I_{\text{rated}}$	$T_{\text{B}}/T_{\text{rated}}$	CL	$J$ kg m <sup>2</sup>	For Order No. supplements for voltage and type of construction, see table below		IM B3 type of construction approx. $m$ kg	
<b>2-pole, 3000 rpm at 50 Hz, temperature class 155 (F), used acc. to temperature class 130 (B), IP55 degree of protection, with reduced output</b>															
7.3	180 M	2945	24	91.0	0.89	13	2.4	6.5	3.4	16	0.068	<b>1LP4 183-2FA□□</b>		140	
10	200 L	2950	32	90.9	0.89	17.8	2.3	6.4	2.9	16	0.129	<b>1LP4 206-2FA□□</b>		195	
12.5	200 L	2955	40	91.9	0.90	22	2.5	7.1	3.2	16	0.153	<b>1LP4 207-2FA□□</b>		215	
15	225 M	2960	48	93.2	0.90	26	2.3	6.7	3.0	16	0.217	<b>1LP4 223-2FA□□</b>		275	
18.5	250 M	2970	59	92.6	0.89	32.5	2.0	6.6	3.0	13	0.403	<b>1LP4 253-2FB□□</b>		360	
25	280 S	2975	80	93.8	0.90	42.5	2.5	7.6	3.0	13	0.715	<b>1LP4 280-2FB□□</b>		480	
30	280 M	2975	96	94.4	0.90	51	2.6	7.2	2.9	13	0.832	<b>1LP4 283-2FB□□</b>		520	
37	315 S	2984	118	94.5	0.90	63	2.3	7.3	3.0	13	1.19	<b>1LP4 310-2FB□□</b>		700	
44	315 M	2982	141	94.0	0.91	74	2.3	6.8	2.8	13	1.39	<b>1LP4 313-2FB□□</b>		755	
53	315 L	2982	170	94.6	0.91	89	2.3	6.9	2.9	13	1.62	<b>1LP4 316-2FB□□</b>		880	
67	315 L	2984	214	95.1	0.92	110	2.1	6.5	2.8	13	2.09	<b>1LP4 317-2FB□□</b>		995	

### Order No. supplements

Motor type	Penultimate position: Voltage code				Final position: Type of construction code								
	50 Hz				60 Hz		Without flange	With flange		With standard flange		With special flange	
	230 V $\Delta$ /400 VY	400 V $\Delta$ /690 VY	500 VY	500 V $\Delta$	460 VY	460 V $\Delta$	IM B3/6/7/8, IM V6, IM V5 without protective cover <sup>1)</sup>	IM B5, IM V1 without protective cover <sup>2)</sup>	IM V1 without protective cover <sup>2)</sup>	IM B35	IM B14, IM V19, IM V18 without protective cover	IM B34	IM B14, IM V19, IM V18 without protective cover
	1	6	3	5	1	6	0	1	8	6	2	7	3
<b>1LP4 18</b> . . . . □□	○	○	○	○	○	○	□	✓	–	✓	–	–	–
<b>1LP4 20</b> . . . . □□	○	○	○	○	○	○	□	✓	–	✓	–	–	–
<b>1LP4 22</b> . . . . □□	○	○	○	○	○	○	□	✓	–	✓	–	–	–
<b>1LP4 25</b> . . . . □□	○	○	○	○	○	○	□	✓	–	✓	–	–	–
<b>1LP4 28</b> . . . . □□	○	○	○	○	○	○	□	✓	–	✓	–	–	–
<b>1LP4 310</b> . . . . □□	○	○	○	○	○	○	□	✓	–	✓	–	–	–
<b>1LP4 313</b> . . . . □□	○	○	○	○	○	○	□	✓	–	✓	–	–	–
<b>1LP4 316</b> . . . . □□	–	○	–	○	–	○	□ <sup>3)</sup>	–	✓ <sup>4)</sup>	✓	–	–	–
<b>1LP4 317</b> . . . . □□	–	○	–	○	–	○	□ <sup>3)</sup>	–	✓ <sup>4)</sup>	✓	–	–	–

- Standard version
- Without additional charge
- ✓ With additional charge
- Not possible

Order other voltages with voltage code **9** in the penultimate position and the corresponding order code (see "Special versions" in the "Selection and ordering data" under "Voltages").

Order other types of construction with type of construction code **9** in the final position and the corresponding order code (see "Special versions" in the "Selection and ordering data" under "Types of construction").

- 1) If motors 1LP4 183... to 1LP4 317... (motor series 1LP4 frame sizes 180 M to 315 L) in types of construction with feet IM B6, IM B7, IM V6 or IM V5 without protective cover are fixed to the wall, it is recommended that the motor feet are supported.
- 2) 1LP4 220... to 1LP4 317... motors (motor series 1LP4 frame sizes 225 S to 315 L) are supplied with two screw-in eyebolts in accordance with IM B5, whereby one can be rotated in accordance with IM V1 or IM V3. It is important to note that stress must not be applied perpendicular to the ring plane.

- 3) Type of construction IM V6 and IM V5 without protective cover is only possible using type of construction code **9** and order code **M1E** or **M1D**.
- 4) 2-pole motors in 60 Hz version available on request.



# IEC Squirrel-Cage Motors

## Standard motors up to frame size 315 L

Self-cooled motors without external fan  
Cast-iron series 1LP4

### Selection and ordering data (continued)

Rated output at 50 Hz	Frame size	Operating values at rated output					Locked-rotor torque with direct starting torque	Locked-rotor current	Break-down torque	Torque class	Moment of inertia	Order No.	Price	Weight
		Rated speed at 50 Hz	Rated torque at 50 Hz	Efficiency at 50 Hz 4/4-load	Power factor at 50 Hz 4/4-load	Rated current at 50 Hz 400 V								
$P_{rated}$ kW	FS	$n_{rated}$ rpm	$T_{rated}$ Nm	$\eta_{rated}$ %	$\cos\phi_{rated}$	$I_{rated}$ A	$T_{LR}/T_{rated}$	$I_{LR}/I_{rated}$	$T_B/T_{rated}$	CL	$J$ kg m <sup>2</sup>		$m$ kg	
<b>4-pole, 1500 rpm at 50 Hz, temperature class 155 (F), used acc. to temperature class 130 (B), IP55 degree of protection, with reduced output</b>														
6.2	180 M	1465	40	90.6	0.87	11.4	2.1	6.6	3.0	16	0.099	<b>1LP4 183-4FA□□</b>	135	
7.3	180 L	1470	47	91.2	0.87	13.2	2.1	6.9	3.1	16	0.117	<b>1LP4 186-4FA□□</b>	150	
10	200 L	1465	65	90.5	0.88	18.2	2.3	6.6	3.2	16	0.191	<b>1LP4 207-4FA□□</b>	195	
12.5	225 S	1475	81	92.2	0.86	23	2.3	6.6	3.0	16	0.374	<b>1LP4 220-4FA□□</b>	255	
15	225 M	1475	97	93.1	0.87	26.5	2.4	7.1	3.1	16	0.447	<b>1LP4 223-4FA□□</b>	290	
18.5	250 M	1480	119	93.5	0.87	33	2.2	6.0	2.6	16	0.688	<b>1LP4 253-4FA□□</b>	375	
25	280 S	1485	161	93.9	0.87	44	2.4	7.0	2.9	16	1.19	<b>1LP4 280-4FA□□</b>	515	
30	280 M	1485	193	94.4	0.88	52	2.4	7.2	2.9	16	1.39	<b>1LP4 283-4FA□□</b>	560	
37	315 S	1488	237	94.4	0.87	65	2.2	6.2	2.6	16	1.94	<b>1LP4 310-4FA□□</b>	710	
44	315 M	1488	282	95.2	0.87	77	2.4	6.7	2.7	16	2.31	<b>1LP4 313-4FA□□</b>	790	
53	315 L	1488	340	95.5	0.87	92	2.5	6.7	2.7	16	2.88	<b>1LP4 316-4FA□□</b>	935	
67	315 L	1488	430	95.7	0.88	114	2.3	6.2	2.6	16	3.46	<b>1LP4 317-4FA□□</b>	1040	

### Order No. supplements

Motor type	Penultimate position: Voltage code				Final position: Type of construction code									
	50 Hz				60 Hz		Without flange	With flange		With standard flange		With special flange		
	230 VΔ/400 VY	400 VΔ/690 VY	500 VY	500 VΔ	460 VY	460 VΔ	IM B3/6/7/8, IM V6, IM V5 without protective cover <sup>1)</sup>	IM B5, IM V1 without protective cover <sup>2)</sup>	IM V1 without protective cover <sup>2)</sup>	IM V3	IM B35	IM B14, IM V19, IM V18 without protective cover	IM B34	IM B14, IM V19, IM V18 without protective cover
	1	6	3	5	1	6	0	1	8	6	2	7	3	
<b>1LP4 18</b> - . . . □□	○	○	○	○	○	○	□	✓	-	✓	-	-	-	
<b>1LP4 20</b> - . . . □□	○	○	○	○	○	○	□	✓	-	✓	-	-	-	
<b>1LP4 22</b> - . . . □□	○	○	○	○	○	○	□	✓	-	✓	-	-	-	
<b>1LP4 25</b> - . . . □□	○	○	○	○	○	○	□	✓	-	✓	-	-	-	
<b>1LP4 28</b> - . . . □□	○	○	○	○	○	○	□	✓	-	✓	-	-	-	
<b>1LP4 310</b> - . . . □□	○	○	○	○	○	○	□	✓	-	✓	-	-	-	
<b>1LP4 313</b> - . . . □□	○	○	○	○	○	○	□	✓	-	✓	-	-	-	
<b>1LP4 316</b> - . . . □□	-	○	-	○	-	○	□ <sup>3)</sup>	-	✓	✓	-	-	-	
<b>1LP4 317</b> - . . . □□	-	○	-	○	-	○	□ <sup>3)</sup>	-	✓	✓	-	-	-	

- Standard version
- Without additional charge
- ✓ With additional charge
- Not possible

Order other voltages with voltage code **9** in the penultimate position and the corresponding order code (see "Special versions" in the "Selection and ordering data" under "Voltages").

Order other types of construction with type of construction code **9** in the final position and the corresponding order code (see "Special versions" in the "Selection and ordering data" under "Types of construction").

- 1) If motors 1LP4 183... to 1LP4 317... (motor series 1LP4 frame sizes 180 M to 315 L) in types of construction with feet IM B6, IM B7, IM V6 or IM V5 without protective cover are fixed to the wall, it is recommended that the motor feet are supported.
- 2) 1LP4 220... to 1LP4 317... motors (motor series 1LP4 frame sizes 225 S to 315 L) are supplied with two screw-in eyebolts in accordance with IM B5, whereby one can be rotated in accordance with IM V1 or IM V3. It is important to note that stress must not be applied perpendicular to the ring plane.

- 3) Type of construction IM V6 and IM V5 without protective cover is only possible using type of construction code **9** and order code **M1E** or **M1D**.

# IEC Squirrel-Cage Motors

## Standard motors up to frame size 315 L

**Self-cooled motors without external fan**  
**Cast-iron series 1LP4**

**Selection and ordering data** (continued)

Rated output at 50 Hz	Frame size	Operating values at rated output					Rated current at 50 Hz 400 V	Locked-rotor torque with direct starting torque	Locked-rotor current starting as multiple of rated current	Break-down torque	Torque class	Moment of inertia	Order No.	Price	Weight
		Rated speed at 50 Hz	Rated torque at 50 Hz	Efficiency at 50 Hz 4/4-load	Power factor at 50 Hz 4/4-load	Rated current at 50 Hz 400 V									
$P_{rated}$ kW	FS	$n_{rated}$ rpm	$T_{rated}$ Nm	$\eta_{rated}$ %	$\cos\phi_{rated}$	$I_{rated}$ A	$T_{LR}/T_{rated}$	$I_{LR}/I_{rated}$	$T_B/T_{rated}$	CL	J kg m <sup>2</sup>	For Order No. supplements for voltage and type of construction, see table below		IM B3 type of construction approx. m kg	
<b>6-pole, 1000 rpm at 50 Hz, temperature class 155 (F), used acc. to temperature class 130 (B), IP55 degree of protection, with reduced output</b>															
5	180 L	970	49	89.4	0.83	10	2.1	5.3	2.4	16	0.175	<b>1LP4 186-6FA□□</b>		145	
6.2	200 L	975	61	90.4	0.83	12	2.2	5.7	2.4	16	0.238	<b>1LP4 206-6FA□□</b>		185	
7.3	200 L	975	71	90.8	0.82	14.2	2.3	5.8	2.4	16	0.287	<b>1LP4 207-6FA□□</b>		195	
10	225 M	980	97	92.1	0.84	18.6	2.3	5.5	2.4	16	0.492	<b>1LP4 223-6FA□□</b>		270	
12.5	250 M	982	122	92.5	0.84	23	2.3	5.8	2.2	16	0.762	<b>1LP4 253-6FA□□</b>		355	
15	280 S	986	145	92.5	0.86	27	2.1	6.0	2.3	16	1.12	<b>1LP4 280-6FA□□</b>		455	
18.5	280 M	986	179	92.9	0.86	33.5	2.1	6.0	2.4	16	1.37	<b>1LP4 283-6FA□□</b>		490	
25	315 S	990	241	93.9	0.87	44	2.2	6.6	2.7	16	2.10	<b>1LP4 310-6FA□□</b>		665	
30	315 M	988	290	94.2	0.86	53	2.3	6.8	2.8	16	2.50	<b>1LP4 313-6FA□□</b>		730	
37	315 L	988	358	94.5	0.87	65	2.2	6.6	2.7	16	3.20	<b>1LP4 316-6FA□□</b>		870	
44	315 L	990	424	94.9	0.87	77	2.7	7.2	2.9	16	4.02	<b>1LP4 317-6FA□□</b>		960	

**Order No. supplements**

Motor type	Penultimate position: Voltage code				Final position: Type of construction code								
	50 Hz				60 Hz		Without flange	With flange		With standard flange		With special flange	
	230 VΔ/400 VY	400 VΔ/690 VY	500 VY	500 VΔ	460 VY	460 VΔ	IM B3/6/7/8, IM V6, IM V5 without protective cover <sup>1)</sup>	IM B5, IM V1 without protective cover <sup>2)</sup>	IM V1 without protective cover <sup>2)</sup>	IM B35	IM B14, IM V19, IM V18 without protective cover	IM B34	IM B14, IM V19, IM V18 without protective cover
	<b>1</b>	<b>6</b>	<b>3</b>	<b>5</b>	<b>1</b>	<b>6</b>	<b>0</b>	<b>1</b>	<b>8</b>	<b>6</b>	<b>2</b>	<b>7</b>	<b>3</b>
<b>1LP4 18 - . . . □□</b>	○	○	○	○	○	○	□	✓	-	✓	-	-	-
<b>1LP4 20 - . . . □□</b>	○	○	○	○	○	○	□	✓	-	✓	-	-	-
<b>1LP4 22 - . . . □□</b>	○	○	○	○	○	○	□	✓	-	✓	-	-	-
<b>1LP4 25 - . . . □□</b>	○	○	○	○	○	○	□	✓	-	✓	-	-	-
<b>1LP4 28 - . . . □□</b>	○	○	○	○	○	○	□	✓	-	✓	-	-	-
<b>1LP4 310 - . . . □□</b>	○	○	○	○	○	○	□	✓	-	✓	-	-	-
<b>1LP4 313 - . . . □□</b>	○	○	○	○	○	○	□	✓	-	✓	-	-	-
<b>1LP4 316 - . . . □□</b>	-	○	-	○	-	○	□ <sup>3)</sup>	-	✓	✓	-	-	-
<b>1LP4 317 - . . . □□</b>	-	○	-	○	-	○	□ <sup>3)</sup>	-	✓	✓	-	-	-

- Standard version
- Without additional charge
- ✓ With additional charge
- Not possible

Order other voltages with voltage code **9** in the penultimate position and the corresponding order code (see "Special versions" in the "Selection and ordering data" under "Voltages").

Order other types of construction with type of construction code **9** in the final position and the corresponding order code (see "Special versions" in the "Selection and ordering data" under "Types of construction").

<sup>1)</sup> If motors 1LP4 183-... to 1LP4 317-... (motor series 1LP4 frame sizes 180 M to 315 L) in types of construction with feet IM B6, IM B7, IM V6 or IM V5 without protective cover are fixed to the wall, it is recommended that the motor feet are supported.

<sup>2)</sup> 1LP4 220-... to 1LP4 317-... motors (motor series 1LP4 frame sizes 225 S to 315 L) are supplied with two screw-in eyebolts in accordance with IM B5, whereby one can be rotated in accordance with IM V1 or IM V3. It is important to note that stress must not be applied perpendicular to the ring plane.

<sup>3)</sup> Type of construction IM V6 and IM V5 without protective cover is only possible using type of construction code **9** and order code **M1E** or **M1D**.

# IEC Squirrel-Cage Motors

## Standard motors up to frame size 315 L

Self-cooled motors without external fan  
Cast-iron series 1LP4

### Selection and ordering data (continued)

Rated output at 50 Hz	Frame size	Operating values at rated output					Rated current at 50 Hz 400 V	Locked-rotor torque with direct starting torque	Locked-rotor current	Break-down torque	Torque class	Moment of inertia	Order No.	Price	Weight
		Rated speed at 50 Hz	Rated torque at 50 Hz	Efficiency at 50 Hz 4/4-load	Power factor at 50 Hz 4/4-load	Rated current at 50 Hz 400 V									
$P_{rated}$ kW	FS	$n_{rated}$ rpm	$T_{rated}$ Nm	$\eta_{rated}$ %	$\cos\phi_{rated}$	$I_{rated}$ A	$T_{LR}/T_{rated}$	$I_{LR}/I_{rated}$	$T_B/T_{rated}$	CL	$J$ kg m <sup>2</sup>	For Order No. supplements for voltage and type of construction, see table below		IM B3 type of construction approx. $m$ kg	
<b>8-pole, 750 rpm at 50 Hz, temperature class 155 (F), used acc. to temperature class 130 (B), IP55 degree of protection, with reduced output</b>															
3.7	180 L	725	49	88.4	0.76	10	1.5	4.4	2.0	13	0.169	<b>1LP4 186-8FB□□</b>		145	
5	200 L	730	65	88.3	0.78	10.4	2.0	5.1	2.5	13	0.290	<b>1LP4 207-8FB□□</b>		195	
6.2	225 S	735	81	89.8	0.80	12.4	2.1	5.6	2.6	13	0.482	<b>1LP4 220-8FB□□</b>		260	
7.3	225 M	735	95	90.2	0.81	14.4	2.1	5.7	2.7	13	0.551	<b>1LP4 223-8FB□□</b>		280	
10	250 M	735	130	91.6	0.82	19.2	2.0	5.4	2.5	13	0.837	<b>1LP4 253-8FB□□</b>		370	
12.5	280 S	735	162	92.3	0.82	24	1.9	4.9	2.1	13	1.11	<b>1LP4 280-8FB□□</b>		455	
15	280 M	735	195	92.6	0.81	29	1.9	5.0	2.0	13	1.35	<b>1LP4 283-8FB□□</b>		495	
18.5	315 S	740	239	93.2	0.83	34.5	2.0	5.8	2.5	13	2.08	<b>1LP4 310-8FB□□</b>		660	
25	315 M	738	323	93.5	0.84	46	2.0	5.7	2.5	13	2.48	<b>1LP4 313-8FB□□</b>		725	
30	315 L	740	387	93.6	0.84	55	2.0	5.8	2.6	13	3.14	<b>1LP4 316-8FB□□</b>		845	
37	315 L	740	477	94.1	0.84	68	2.2	6.0	2.7	13	3.95	<b>1LP4 317-8FB□□</b>		1000	

### Order No. supplements

Motor type	Penultimate position: Voltage code				Final position: Type of construction code								
	50 Hz				60 Hz		Without flange	With flange		With standard flange		With special flange	
	230 VΔ/400 VY	400 VΔ/690 VY	500 VY	500 VΔ	460 VY	460 VΔ	IM B3/6/7/8, IM V6, IM V5 without protective cover <sup>1)</sup>	IM B5, IM V1 without protective cover <sup>2)</sup>	IM V1 without protective cover <sup>2)</sup>	IM B35	IM B14, IM V19, IM V18 without protective cover	IM B34	IM B14, IM V19, IM V18 without protective cover
	<b>1</b>	<b>6</b>	<b>3</b>	<b>5</b>	<b>1</b>	<b>6</b>	<b>0</b>	<b>1</b>	<b>8</b>	<b>6</b>	<b>2</b>	<b>7</b>	<b>3</b>
<b>1LP4 18</b> . . . . . □□	○	○	○	○	○	○	□	✓	–	✓	–	–	–
<b>1LP4 20</b> . . . . . □□	○	○	○	○	○	○	□	✓	–	✓	–	–	–
<b>1LP4 22</b> . . . . . □□	○	○	○	○	○	○	□	✓	–	✓	–	–	–
<b>1LP4 25</b> . . . . . □□	○	○	○	○	○	○	□	✓	–	✓	–	–	–
<b>1LP4 28</b> . . . . . □□	○	○	○	○	○	○	□	✓	–	✓	–	–	–
<b>1LP4 310</b> . . . . . □□	○	○	○	○	○	○	□	✓	–	✓	–	–	–
<b>1LP4 313</b> . . . . . □□	○	○	○	○	○	○	□	✓	–	✓	–	–	–
<b>1LP4 316</b> . . . . . □□	–	○	–	○	–	○	□ <sup>3)</sup>	–	✓	✓	–	–	–
<b>1LP4 317</b> . . . . . □□	–	○	–	○	–	○	□ <sup>3)</sup>	–	✓	✓	–	–	–

- Standard version
- Without additional charge
- ✓ With additional charge
- Not possible

Order other voltages with voltage code **9** in the penultimate position and the corresponding order code (see "Special versions" in the "Selection and ordering data" under "Voltages").

Order other types of construction with type of construction code **9** in the final position and the corresponding order code (see "Special versions" in the "Selection and ordering data" under "Types of construction").

- 1) If motors 1LP4 183... to 1LP4 317... (motor series 1LP4 frame sizes 180 M to 315 L) in types of construction with feet IM B6, IM B7, IM V6 or IM V5 without protective cover are fixed to the wall, it is recommended that the motor feet are supported.
- 2) 1LP4 220... to 1LP4 317... motors (motor series 1LP4 frame sizes 225 S to 315 L) are supplied with two screw-in eyebolts in accordance with IM B5, whereby one can be rotated in accordance with IM V1 or IM V3. It is important to note that stress must not be applied perpendicular to the ring plane.

- 3) Type of construction IM V6 and IM V5 without protective cover is only possible using type of construction code **9** and order code **M1E** or **M1D**.

# IEC Squirrel-Cage Motors

## Standard motors up to frame size 315 L

### Special versions

#### Overview

Category	Explanation
Voltages	For standard voltages, see the corresponding Order No. supplements in the selection and ordering data. For other voltages with voltage code <b>9</b> and the required order code, see "Special versions", "Selection and ordering data". For further information and details, see catalog part 0 "Introduction".
Types of construction	For standard construction types, see the corresponding Order No. supplements in the selection and ordering data. For other types of construction using type of construction code <b>9</b> and the required order code, see "Special versions", "Selection and ordering data". For further information and details, see catalog part 0 "Introduction".
Motor protection	For an overview of the relevant order codes, see "Special versions", "Selection and ordering data".
Motor connection and connection box	For further information and details, see catalog part 0 "Introduction".
Windings and insulation	
Colors and paint finish	
Modular technology – Basic versions	
Modular technology – Combinations of basic versions	
Modular technology – Additional versions	
Special technology	
Mechanical design and degrees of protection	
Coolant temperature and site altitude	
Designs in accordance with standards and specifications	
Bearings and lubrication	
Balance and vibration quantity	
Shaft and rotor	
Heating and ventilation	
Rating plate and extra rating plates	
Packaging, safety notes, documentation and test certificates	
Design for Zones 1, 2, 21 and 22 according to ATEX	See catalog part 4 "Explosion-proof motors"
Ship version	See catalog part 10 "Marine motors"

# IEC Squirrel-Cage Motors

## Standard motors up to frame size 315 L

Special versions

## Selection and ordering data

## Voltages

Additional order codes for other voltages or voltage codes  
(without **-Z** supplement)

For some non-standard voltages at 50 or 60 Hz, order codes are specified. They are ordered by specifying the code digit **9** for voltage in the 11th position of the Order No. and the appropriate order code.

Special versions	Voltage code 11th position of the Order No.	Additional identifica- tion code with order code and plain text if required	Motor type frame size													
			56	63	71	80	90	100	112	132	160	180	200	225	250	280
<b>Self-ventilated energy-saving motors with improved efficiency – Aluminum series 1LA7 and 1LA5</b>																
			<b>1LA7 (aluminum)</b>								<b>1LA5 (aluminum)</b>					
<b>Voltage at 50 Hz</b>																
220 VΔ/380 VY (440 VY at 60 Hz) (210 ... 230 VΔ/360 ... 400 VY); 50 Hz output <sup>1)</sup>	9	L1R	✓	✓	✓	✓	✓	✓	✓	✓	✓	✓	✓	✓	✓	✓
230 VΔ (220 ... 240 VΔ); 50 Hz output <sup>1)</sup>	9	L1E	○	○	○	○	○	○	○	○	○	○	○	○	○	○
380 VΔ/660 VY (440 VΔ at 60 Hz) (360 ... 400 VΔ/625 ... 695 VY); 50 Hz output <sup>1)</sup>	9	L1L	✓	✓	✓	✓	✓	✓	✓	✓	✓	✓	✓	✓	✓	✓
415 VY (395 ... 435 VY); 50 Hz output <sup>1)</sup>	9	L1C	✓	✓	✓	✓	✓	✓	✓	✓	✓	✓	✓	✓	✓	✓
415 VΔ (395 ... 435 VΔ); 50 Hz output <sup>1)</sup>	9	L1D	✓	✓	✓	✓	✓	✓	✓	✓	✓	✓	✓	✓	✓	✓
400 VY (380 ... 420 VY); 50 Hz output <sup>1)</sup>	9	L1A	○	○	○	○	○	○	○	○	○	○	○	○	○	○
400 VΔ (380 ... 420 VΔ); 50 Hz output <sup>1)</sup>	9	L1B	○	○	○	○	○	○	○	○	○	○	○	○	○	○
400 VΔ (460 VΔ at 60 Hz) (380 ... 420 VΔ); 50 Hz output <sup>1)</sup>	9	L1U	○	○	○	○	○	○	○	○	○	○	○	○	○	○
<b>Voltage at 60 Hz</b>																
220 VΔ/380 VY; 50 Hz output	9	L2A	✓	✓	✓	✓	✓	✓	✓	✓	✓	✓	✓	✓	✓	✓
220 VΔ/380 VY; 60 Hz output	9	L2B	✓	✓	✓	✓	✓	✓	✓	✓	✓	✓	✓	✓	✓	✓
380 VΔ/660 VY; 50 Hz output	9	L2C	✓	✓	✓	✓	✓	✓	✓	✓	✓	✓	✓	✓	✓	✓
380 VΔ/660 VY; 60 Hz output	9	L2D	✓	✓	✓	✓	✓	✓	✓	✓	✓	✓	✓	✓	✓	✓
440 VY; 50 Hz output	9	L2Q	✓	✓	✓	✓	✓	✓	✓	✓	✓	✓	✓	✓	✓	✓
440 VY; 60 Hz output	9	L2W	✓	✓	✓	✓	✓	✓	✓	✓	✓	✓	✓	✓	✓	✓
440 VΔ; 50 Hz output	9	L2R	✓	✓	✓	✓	✓	✓	✓	✓	✓	✓	✓	✓	✓	✓
440 VΔ; 60 Hz output	9	L2X	✓	✓	✓	✓	✓	✓	✓	✓	✓	✓	✓	✓	✓	✓
460 VY; 50 Hz output	9	L2S	✓	✓	✓	✓	✓	✓	✓	✓	✓	✓	✓	✓	✓	✓
460 VY; 60 Hz output	9	L2E	○	○	○	○	○	○	○	○	○	○	○	○	○	○
460 VΔ; 50 Hz output	9	L2T	✓	✓	✓	✓	✓	✓	✓	✓	✓	✓	✓	✓	✓	✓
460 VΔ; 60 Hz output	9	L2F	○	○	○	○	○	○	○	○	○	○	○	○	○	○
575 VY; 50 Hz output	9	L2U	✓	✓	✓	✓	✓	✓	✓	✓	✓	✓	✓	✓	✓	✓
575 VY; 60 Hz output	9	L2L	✓	✓	✓	✓	✓	✓	✓	✓	✓	✓	✓	✓	✓	✓
575 VΔ; 50 Hz output	9	L2V	✓	✓	✓	✓	✓	✓	✓	✓	✓	✓	✓	✓	✓	✓
575 VΔ; 60 Hz output	9	L2M	✓	✓	✓	✓	✓	✓	✓	✓	✓	✓	✓	✓	✓	✓
<b>Voltage changeover at 60 Hz</b>																
230 VYY/460 VY 60 Hz; 50 Hz output, 9 main terminals and electrical design to NEMA <sup>3)</sup>	9	L3E	✓	✓	✓	✓	✓	✓	✓	✓	✓	✓	✓	✓	✓	-
230 VYY/460 VY 60 Hz; 60 Hz output, 9 main terminals and electrical design to NEMA <sup>3)</sup>	9	L3F	✓	✓	✓	✓	✓	✓	✓	✓	✓	✓	✓	✓	✓	-
230 VΔΔ/460 VΔ 60 Hz; 50 Hz output, 12 main terminals and electrical design to NEMA	9	L3G	-	-	-	-	-	✓	✓	✓	✓	✓	✓	✓	-	-
230 VΔΔ/460 VΔ 60 Hz; 60 Hz output, 12 main terminals and electrical design to NEMA	9	L3H	-	-	-	-	-	✓	✓	✓	✓	✓	✓	✓	-	-
<b>Non-standard voltages and/or frequencies</b>																
Non-standard winding for vol- tages between 200 and 690 V (voltages outside this range are available on request) <sup>2)</sup>	9	L1Y •	✓	✓	✓	✓	✓	✓	✓	✓	✓	✓	✓	✓	✓	✓

For legend and footnotes, see Page 2/68.

# IEC Squirrel-Cage Motors

## Standard motors up to frame size 315 L

### Special versions

Special versions	Voltage code 11th position of the Order No.	Additional identifica- tion code with order code and plain text if required	Motor type frame size														
			56	63	71	80	90	100	112	132	160	180	200	225	250	280	315
<b>Self-ventilated energy-saving motors with improved efficiency in pole-changing version – Aluminum series 1LA7 and 1LA5</b>																	
			<b>1LA7 (aluminum)</b>								<b>1LA5 (alu- minum)</b>						
<b>Voltage 60 Hz</b>																	
220 V; 50 Hz output	9	L4A	✓	✓	✓	✓	✓	✓	✓	✓	✓	✓	✓	✓	✓	✓	✓
220 V; 60 Hz output	9	L4B	✓	✓	✓	✓	✓	✓	✓	✓	✓	✓	✓	✓	✓	✓	✓
380 V; 50 Hz output	9	L4C	✓	✓	✓	✓	✓	✓	✓	✓	✓	✓	✓	✓	✓	✓	✓
380 V; 60 Hz output	9	L4D	✓	✓	✓	✓	✓	✓	✓	✓	✓	✓	✓	✓	✓	✓	✓
440 V; 50 Hz output	9	L4G	✓	✓	✓	✓	✓	✓	✓	✓	✓	✓	✓	✓	✓	✓	✓
440 V; 60 Hz output	9	L4E	✓	✓	✓	✓	✓	✓	✓	✓	✓	✓	✓	✓	✓	✓	✓
460 V; 50 Hz output	9	L4J	✓	✓	✓	✓	✓	✓	✓	✓	✓	✓	✓	✓	✓	✓	✓
460 V; 60 Hz output	9	L4H	✓	✓	✓	✓	✓	✓	✓	✓	✓	✓	✓	✓	✓	✓	✓
575 V; 50 Hz output	9	L4N	✓	✓	✓	✓	✓	✓	✓	✓	✓	✓	✓	✓	✓	✓	✓
575 V; 60 Hz output	9	L4M	✓	✓	✓	✓	✓	✓	✓	✓	✓	✓	✓	✓	✓	✓	✓
<b>Non-standard voltage and/or frequencies</b>																	
Non-standard winding for vol- tages between 200 and 690 V (voltages outside this range are available on request) <sup>2)</sup>	9	L1Y •	✓	✓	✓	✓	✓	✓	✓	✓	✓	✓	✓	✓	✓	✓	✓
Non-standard winding for Y/Δ starting at low speed <sup>2)</sup>	9	L3Y •	–	–	–	–	–	✓	✓	✓	✓	✓	✓	✓	✓	✓	✓

- Without additional charge
- ✓ With additional charge
- Not possible
- This order code only determines the price of the version –  
Additional plain text is required.

<sup>1)</sup> With order codes **L1A, L1B, L1C, L1D, L1E, L1L, L1R** and **L1U**, a rated voltage range is also specified on the rating plate.

<sup>2)</sup> Plain text must be specified in the order: Voltage, frequency, circuit, required rated output in kW.

<sup>3)</sup> When ordered with option brake (order code **G26**) only 6 motor connection terminals are possible for frame size 56 to 90.

# IEC Squirrel-Cage Motors

## Standard motors up to frame size 315 L

**Special versions**

Special versions	Voltage code	Additional identification code with order code and plain text if required	Motor type frame size													
			56	63	71	80	90	100	112	132	160	180	200	225	250	280
<b>Self-ventilated energy-saving motors with high efficiency – Aluminum series 1LA9</b>																
<b>1LA9 (aluminum)</b>																
<b>Voltage at 50 Hz</b>																
220 VΔ/380 VY (440 VY at 60 Hz) (210 ... 230 VΔ/360 ... 400 VY); 50 Hz output <sup>1)</sup>	9	L1R	✓	✓	✓	✓	✓	✓	✓	✓	✓	✓	✓	✓	✓	✓
230 VΔ (220 ... 240 VΔ); 50 Hz output <sup>1)</sup>	9	L1E	○	○	○	○	○	○	○	○	○	○	○	○	○	○
380 VΔ/660 VY (440 VΔ at 60 Hz) (360 ... 400 VΔ/625 ... 695 VY); 50 Hz output <sup>1)</sup>	9	L1L	✓	✓	✓	✓	✓	✓	✓	✓	✓	✓	✓	✓	✓	✓
415 VY (395 ... 435 VY); 50 Hz output <sup>1)</sup>	9	L1C	✓	✓	✓	✓	✓	✓	✓	✓	✓	✓	✓	✓	✓	✓
415 VΔ (395 ... 435 VΔ); 50 Hz output <sup>1)</sup>	9	L1D	✓	✓	✓	✓	✓	✓	✓	✓	✓	✓	✓	✓	✓	✓
400 VY (380 ... 420 VY); 50 Hz output <sup>1)</sup>	9	L1A	○	○	○	○	○	○	○	○	○	○	○	○	○	○
400 VΔ (380 ... 420 VΔ); 50 Hz output <sup>1)</sup>	9	L1B	○	○	○	○	○	○	○	○	○	○	○	○	○	○
400 VΔ (460 VΔ at 60 Hz) (380 ... 420 VΔ); 50 Hz output <sup>1)</sup>	9	L1U	○	○	○	○	○	○	○	○	○	○	○	○	○	○
<b>Voltage at 60 Hz</b>																
220 VΔ/380 VY; 50 Hz output	9	L2A	✓	✓	✓	✓	✓	✓	✓	✓	✓	✓	✓	✓	✓	✓
220 VΔ/380 VY; 60 Hz output	9	L2B	✓	✓	✓	✓	✓	✓	✓	✓	✓	✓	✓	✓	✓	✓
380 VΔ/660 VY; 50 Hz output	9	L2C	✓	✓	✓	✓	✓	✓	✓	✓	✓	✓	✓	✓	✓	✓
380 VΔ/660 VY; 60 Hz output	9	L2D	✓	✓	✓	✓	✓	✓	✓	✓	✓	✓	✓	✓	✓	✓
440 VY; 50 Hz output	9	L2Q	✓	✓	✓	✓	✓	✓	✓	✓	✓	✓	✓	✓	✓	✓
440 VY; 60 Hz output	9	L2W	✓	✓	✓	✓	✓	✓	✓	✓	✓	✓	✓	✓	✓	✓
440 VΔ; 50 Hz output	9	L2R	✓	✓	✓	✓	✓	✓	✓	✓	✓	✓	✓	✓	✓	✓
440 VΔ; 60 Hz output	9	L2X	✓	✓	✓	✓	✓	✓	✓	✓	✓	✓	✓	✓	✓	✓
460 VY; 50 Hz output	9	L2S	✓	✓	✓	✓	✓	✓	✓	✓	✓	✓	✓	✓	✓	✓
460 VY; 60 Hz output	9	L2E	○	○	○	○	○	○	○	○	○	○	○	○	○	○
460 VΔ; 50 Hz output	9	L2T	✓	✓	✓	✓	✓	✓	✓	✓	✓	✓	✓	✓	✓	✓
460 VΔ; 60 Hz output	9	L2F	○	○	○	○	○	○	○	○	○	○	○	○	○	○
575 VY; 50 Hz output	9	L2U	✓	✓	✓	✓	✓	✓	✓	✓	✓	✓	✓	✓	✓	✓
575 VY; 60 Hz output	9	L2L	✓	✓	✓	✓	✓	✓	✓	✓	✓	✓	✓	✓	✓	✓
575 VΔ; 50 Hz output	9	L2V	✓	✓	✓	✓	✓	✓	✓	✓	✓	✓	✓	✓	✓	✓
575 VΔ; 60 Hz output	9	L2M	✓	✓	✓	✓	✓	✓	✓	✓	✓	✓	✓	✓	✓	✓
<b>Voltage changeover at 60 Hz</b>																
230 VYY/460 VY 60 Hz; 50 Hz output, 9 main terminals and electrical design to NEMA	9	L3E	✓	✓	✓	✓	✓	✓	✓	✓	✓	✓	✓	✓	✓	✓
230 VYY/460 VY 60 Hz; 60 Hz output, 9 main terminals and electrical design to NEMA	9	L3F	✓	✓	✓	✓	✓	✓	✓	✓	✓	✓	✓	✓	✓	✓
230 VΔΔ/460 VΔ 60 Hz; 50 Hz output, 12 main terminals and electrical design to NEMA	9	L3G	-	-	-	-	-	✓	✓	✓	✓	✓	✓	✓	✓	✓
230 VΔΔ/460 VΔ 60 Hz; 60 Hz output, 12 main terminals and electrical design to NEMA	9	L3H	-	-	-	-	-	✓	✓	✓	✓	✓	✓	✓	✓	✓
<b>Non-standard voltage and/or frequencies</b>																
Non-standard winding for voltages between 200 and 690 V (voltages outside this range are available on request) <sup>2)</sup>	9	L1Y •	✓	✓	✓	✓	✓	✓	✓	✓	✓	✓	✓	✓	✓	✓

# IEC Squirrel-Cage Motors

## Standard motors up to frame size 315 L

### Special versions

Special versions	Voltage code	11th position of the Order No.	Additional identification code with order code and plain text if required	Motor type frame size													
				56	63	71	80	90	100	112	132	160	180	200	225	250	280
<b>Self-ventilated motors with increased output – Aluminum series 1LA9</b>																	
				<b>1LA9 (aluminum)</b>													
<b>Voltage at 50 Hz</b>																	
220 VΔ/380 VY (440 VY at 60 Hz) (210 ... 230 VΔ/360 ... 400 VY); 50 Hz output <sup>1)</sup>	9		L1R	✓	✓	✓	✓	✓	✓	✓	✓	✓	✓	✓	✓	✓	✓
230 VΔ (220 ... 240 VΔ); 50 Hz output <sup>1)</sup>	9		L1E	○	○	○	○	○	○	○	○	○	○	○	○	○	○
380 VΔ/660 VY (440 VΔ at 60 Hz) (360 ... 400 VΔ/625 ... 695 VY); 50 Hz output <sup>1)</sup>	9		L1L	✓	✓	✓	✓	✓	✓	✓	✓	✓	✓	✓	✓	✓	✓
415 VY (395 ... 435 VY); 50 Hz output <sup>1)</sup>	9		L1C	✓	✓	✓	✓	✓	✓	✓	✓	✓	✓	✓	✓	✓	✓
415 VΔ (395 ... 435 VΔ); 50 Hz output <sup>1)</sup>	9		L1D	✓	✓	✓	✓	✓	✓	✓	✓	✓	✓	✓	✓	✓	✓
400 VY (380 ... 420 VY); 50 Hz output <sup>1)</sup>	9		L1A	○	○	○	○	○	○	○	○	○	○	○	○	○	○
400 VΔ (380 ... 420 VΔ); 50 Hz output <sup>1)</sup>	9		L1B	○	○	○	○	○	○	○	○	○	○	○	○	○	○
400 VΔ (460 VΔ at 60 Hz) (380 ... 420 VΔ); 50 Hz output <sup>1)</sup>	9		L1U	○	○	○	○	○	○	○	○	○	○	○	○	○	○
<b>Voltage at 60 Hz</b>																	
220 VΔ/380 VY; 50 Hz output	9		L2A	✓	✓	✓	✓	✓	✓	✓	✓	✓	✓	✓	✓	✓	✓
220 VΔ/380 VY; 60 Hz output	9		L2B	✓	✓	✓	✓	✓	✓	✓	✓	✓	✓	✓	✓	✓	✓
380 VΔ/660 VY; 50 Hz output	9		L2C	✓	✓	✓	✓	✓	✓	✓	✓	✓	✓	✓	✓	✓	✓
380 VΔ/660 VY; 60 Hz output	9		L2D	✓	✓	✓	✓	✓	✓	✓	✓	✓	✓	✓	✓	✓	✓
440 VY; 50 Hz output	9		L2Q	✓	✓	✓	✓	✓	✓	✓	✓	✓	✓	✓	✓	✓	✓
440 VY; 60 Hz output	9		L2W	✓	✓	✓	✓	✓	✓	✓	✓	✓	✓	✓	✓	✓	✓
440 VΔ; 50 Hz output	9		L2R	✓	✓	✓	✓	✓	✓	✓	✓	✓	✓	✓	✓	✓	✓
440 VΔ; 60 Hz output	9		L2X	✓	✓	✓	✓	✓	✓	✓	✓	✓	✓	✓	✓	✓	✓
460 VY; 50 Hz output	9		L2S	✓	✓	✓	✓	✓	✓	✓	✓	✓	✓	✓	✓	✓	✓
460 VY; 60 Hz output	9		L2E	○	○	○	○	○	○	○	○	○	○	○	○	○	○
460 VΔ; 50 Hz output	9		L2T	✓	✓	✓	✓	✓	✓	✓	✓	✓	✓	✓	✓	✓	✓
460 VΔ; 60 Hz output	9		L2F	○	○	○	○	○	○	○	○	○	○	○	○	○	○
575 VY; 50 Hz output	9		L2U	✓	✓	✓	✓	✓	✓	✓	✓	✓	✓	✓	✓	✓	✓
575 VY; 60 Hz output	9		L2L	✓	✓	✓	✓	✓	✓	✓	✓	✓	✓	✓	✓	✓	✓
575 VΔ; 50 Hz output	9		L2V	✓	✓	✓	✓	✓	✓	✓	✓	✓	✓	✓	✓	✓	✓
575 VΔ; 60 Hz output	9		L2M	✓	✓	✓	✓	✓	✓	✓	✓	✓	✓	✓	✓	✓	✓
<b>Voltage changeover at 60 Hz</b>																	
230 VYY/460 VY 60 Hz; 50 Hz output, 9 main terminals and electrical design to NEMA	9		L3E	✓	✓	✓	✓	✓	✓	✓	✓	✓	✓	✓	✓	✓	✓
230 VYY/460 VY 60 Hz; 60 Hz output, 9 main terminals and electrical design to NEMA	9		L3F	✓	✓	✓	✓	✓	✓	✓	✓	✓	✓	✓	✓	✓	✓
230 VΔΔ/460 VΔ 60 Hz; 50 Hz output, 12 main terminals and electrical design to NEMA	9		L3G	–	–	–	–	–	✓	✓	✓	✓	✓	✓	✓	✓	✓
230 VΔΔ/460 VΔ 60 Hz; 60 Hz output, 12 main terminals and electrical design to NEMA	9		L3H	–	–	–	–	–	✓	✓	✓	✓	✓	✓	✓	✓	✓
<b>Non-standard voltage and/or frequencies</b>																	
Non-standard winding for voltages between 200 and 690 V (voltages outside this range are available on request) <sup>2)</sup>	9		L1Y •	✓	✓	✓	✓	✓	✓	✓	✓	✓	✓	✓	✓	✓	✓

- Without additional charge
- ✓ With additional charge
- Not possible
- This order code only determines the price of the version – Additional plain text is required.

<sup>1)</sup> With order codes **L1A**, **L1B**, **L1C**, **L1D**, **L1E**, **L1L**, **L1R** and **L1U**, a rated voltage range is also specified on the rating plate.

<sup>2)</sup> Plain text must be specified in the order: Voltage, frequency, circuit, required rated output in kW.



# IEC Squirrel-Cage Motors

## Standard motors up to frame size 315 L

### Special versions

Special versions	Voltage code 11th position of the Order No.	Additional identifica- tion code with order code and plain text if required	Motor type frame size														
			56	63	71	80	90	100	112	132	160	180	200	225	250	280	315 S/M
<b>Self-ventilated motors with improved efficiency – Cast-iron series 1LA6 and 1LG4</b>																	
			<b>1LA6 (cast-iron)</b>							<b>1LG4 (cast-iron)</b>							
<b>Voltage at 50 Hz</b>																	
220 VΔ/380 VY (440 VY at 60 Hz) (210 ... 230 VΔ/360 ... 400 VY); 50 Hz output <sup>1)</sup>	9	L1R								✓	✓	✓	✓	✓	✓	✓	–
230 VΔ (220 ... 240 VΔ); 50 Hz output <sup>1)</sup>	9	L1E								○	○	○	○	○	○	○	–
380 VΔ/660 VY (440 VΔ at 60 Hz) (360 ... 400 VΔ/625 ... 695 VY); 50 Hz output <sup>1)</sup>	9	L1L								✓	✓	✓	✓	✓	✓	✓	✓
415 VY (395 ... 435 VY); 50 Hz output <sup>1)</sup>	9	L1C								✓	✓	✓	✓	✓	✓	✓	–
415 VΔ (395 ... 435 VΔ); 50 Hz output <sup>1)</sup>	9	L1D								✓	✓	✓	✓	✓	✓	✓	✓
400 VY (380 ... 420 VY); 50 Hz output <sup>1)</sup>	9	L1A								○	○	○	○	○	○	○	–
400 VΔ (380 ... 420 VΔ); 50 Hz output <sup>1)</sup>	9	L1B								○	○	○	○	○	○	○	○
400 VΔ (460 VΔ at 60 Hz) (380 ... 420 VΔ); 50 Hz output <sup>1)</sup>	9	L1U								○	○	○	○	○	○	○	○
<b>Voltage at 60 Hz</b>																	
220 VΔ/380 VY; 50 Hz output	9	L2A								✓	✓	✓	✓	✓	✓	✓	–
220 VΔ/380 VY; 60 Hz output	9	L2B								✓	✓	✓	✓	✓	✓	✓	–
380 VΔ/660 VY; 50 Hz output	9	L2C								✓	✓	✓	✓	✓	✓	✓	✓
380 VΔ/660 VY; 60 Hz output	9	L2D								✓	✓	✓	✓	✓	✓	✓	✓
440 VY; 50 Hz output	9	L2Q								✓	✓	✓	✓	✓	✓	✓	–
440 VY; 60 Hz output	9	L2W								✓	✓	✓	✓	✓	✓	✓	–
440 VΔ; 50 Hz output	9	L2R								✓	✓	✓	✓	✓	✓	✓	✓
440 VΔ; 60 Hz output	9	L2X								✓	✓	✓	✓	✓	✓	✓	✓
460 VY; 50 Hz output	9	L2S								✓	✓	✓	✓	✓	✓	✓	–
460 VY; 60 Hz output	9	L2E								○	○	○	○	○	○	○	–
460 VΔ; 50 Hz output	9	L2T								✓	✓	✓	✓	✓	✓	✓	✓
460 VΔ; 60 Hz output	9	L2F								○	○	○	○	○	○	○	○
575 VY; 50 Hz output	9	L2U								✓	✓	✓	✓	✓	✓	✓	–
575 VY; 60 Hz output	9	L2L								✓	✓	✓	✓	✓	✓	✓	–
575 VΔ; 50 Hz output	9	L2V								✓	✓	✓	✓	✓	✓	✓	✓
575 VΔ; 60 Hz output	9	L2M								○	○	○	○	○	○	○	○
<b>Non-standard voltage and/or frequencies</b>																	
Non-standard winding for vol- tages between 200 and 690 V (voltages outside this range are available on request) <sup>2)</sup>	9	L1Y •								✓	✓	✓	✓	✓	✓	✓	✓

- Without additional charge
- ✓ With additional charge
- Not possible

• This order code only determines the price of the version –  
Additional plain text is required.

<sup>1)</sup> With order codes **L1A, L1B, L1C, L1D, L1E, L1L, L1R** and **L1U**, a rated voltage range is also specified on the rating plate.

<sup>2)</sup> Plain text must be specified in the order: Voltage, frequency, circuit, required rated output in kW.

# IEC Squirrel-Cage Motors

## Standard motors up to frame size 315 L

### Special versions

Special versions	Voltage code 11th position of the Order No.	Additional identification code with order code and plain text if required	Motor type frame size																
			56	63	71	80	90	100	112	132	160	180	200	225	250	280	315 S/M	315 L	
<b>Self-ventilated motors with increased output – Cast-iron series 1LG4</b>																			
<b>1LG4 (cast-iron)</b>																			
<b>Voltage at 50 Hz</b>																			
220 VΔ/380 VY (440 VY at 60 Hz) (210 ... 230 VΔ/360 ... 400 VY); 50 Hz output <sup>1)</sup>	9	L1R													✓	✓	✓	✓	✓
230 VΔ (220 ... 240 VΔ); 50 Hz output <sup>1)</sup>	9	L1E													○	○	○	○	○
380 VΔ/660 VY (440 VΔ at 60 Hz) (360 ... 400 VΔ/625 ... 695 VY); 50 Hz output <sup>1)</sup>	9	L1L													✓	✓	✓	✓	✓
415 VY (395 ... 435 VY); 50 Hz output <sup>1)</sup>	9	L1C													✓	✓	✓	✓	✓
415 VΔ (395 ... 435 VΔ); 50 Hz output <sup>1)</sup>	9	L1D													✓	✓	✓	✓	✓
400 VY (380 ... 420 VY); 50 Hz output <sup>1)</sup>	9	L1A													○	○	○	○	○
400 VΔ (380 ... 420 VΔ); 50 Hz output <sup>1)</sup>	9	L1B													○	○	○	○	○
400 VΔ (460 VΔ at 60 Hz) (380 ... 420 VΔ); 50 Hz output <sup>1)</sup>	9	L1U													○	○	○	○	○
<b>Voltage at 60 Hz</b>																			
220 VΔ/380 VY; 50 Hz output	9	L2A													✓	✓	✓	✓	✓
220 VΔ/380 VY; 60 Hz output	9	L2B													✓	✓	✓	✓	✓
380 VΔ/660 VY; 50 Hz output	9	L2C													✓	✓	✓	✓	✓
380 VΔ/660 VY; 60 Hz output	9	L2D													✓	✓	✓	✓	✓
440 VY; 50 Hz output	9	L2Q													✓	✓	✓	✓	✓
440 VY; 60 Hz output	9	L2W													✓	✓	✓	✓	✓
440 VΔ; 50 Hz output	9	L2R													✓	✓	✓	✓	✓
440 VΔ; 60 Hz output	9	L2X													✓	✓	✓	✓	✓
460 VY; 50 Hz output	9	L2S													✓	✓	✓	✓	✓
460 VY; 60 Hz output	9	L2E													○	○	○	○	○
460 VΔ; 50 Hz output	9	L2T													✓	✓	✓	✓	✓
460 VΔ; 60 Hz output	9	L2F													○	○	○	○	○
575 VY; 50 Hz output	9	L2U													✓	✓	✓	✓	✓
575 VY; 60 Hz output	9	L2L													✓	✓	✓	✓	✓
575 VΔ; 50 Hz output	9	L2V													✓	✓	✓	✓	✓
575 VΔ; 60 Hz output	9	L2M													○	○	○	○	○
<b>Non-standard voltage and/or frequencies</b>																			
Non-standard winding for voltages between 200 and 690 V (other voltages are available on request) <sup>2)</sup>	9	L1Y													✓	✓	✓	✓	✓

- Without additional charge  
 ✓ With additional charge  
 – Not possible

<sup>1)</sup> With order codes **L1A, L1B, L1C, L1D, L1E, L1L, L1R** and **L1U**, a rated voltage range is also specified on the rating plate.

<sup>2)</sup> Plain text must be specified in the order: Voltage, frequency, circuit, required rated output in kW.

# IEC Squirrel-Cage Motors

## Standard motors up to frame size 315 L

### Special versions

Special versions	Voltage code 11th position of the Order No.	Additional identifica- tion code with order code and plain text if required	Motor type frame size														
			56	63	71	80	90	100	112	132	160	180	200	225	250	280	315 S/M
<b>Self-ventilated energy-saving motors with high efficiency – Cast-iron series 1LG6</b>																	
																<b>1LG6 (cast-iron)</b>	
<b>Voltage at 50 Hz</b>																	
220 VΔ/380 VY (440 VY at 60 Hz) (210 ... 230 VΔ/360 ... 400 VY); 50 Hz output <sup>1)</sup>	9	L1R														✓	–
230 VΔ (220 ... 240 VΔ); 50 Hz output <sup>1)</sup>	9	L1E														○	–
380 VΔ/660 VY (440 VΔ at 60 Hz) (360 ... 400 VΔ/625 ... 695 VY); 50 Hz output <sup>1)</sup>	9	L1L														✓	✓
415 VY (395 ... 435 VY); 50 Hz output <sup>1)</sup>	9	L1C														✓	–
415 VΔ (395 ... 435 VΔ); 50 Hz output <sup>1)</sup>	9	L1D														✓	✓
400 VY (380 ... 420 VY); 50 Hz output <sup>1)</sup>	9	L1A														○	–
400 VΔ (380 ... 420 VΔ); 50 Hz output <sup>1)</sup>	9	L1B														○	○
400 VΔ (460 VΔ at 60 Hz) (380 ... 420 VΔ); 50 Hz output <sup>1)</sup>	9	L1U														○	○
<b>Voltage at 60 Hz</b>																	
220 VΔ/380 VY; 50 Hz output	9	L2A														✓	–
220 VΔ/380 VY; 60 Hz output	9	L2B														✓	–
380 VΔ/660 VY; 50 Hz output	9	L2C														✓	✓
380 VΔ/660 VY; 60 Hz output	9	L2D														✓	✓
440 VY; 50 Hz output	9	L2Q														✓	–
440 VY; 60 Hz output	9	L2W														✓	–
440 VΔ; 50 Hz output	9	L2R														✓	✓
440 VΔ; 60 Hz output	9	L2X														✓	✓
460 VY; 50 Hz output	9	L2S														✓	–
460 VY; 60 Hz output	9	L2E														○	–
460 VΔ; 50 Hz output	9	L2T														✓	✓
460 VΔ; 60 Hz output	9	L2F														○	○
575 VY; 50 Hz output	9	L2U														✓	–
575 VY; 60 Hz output	9	L2L														✓	–
575 VΔ; 50 Hz output	9	L2V														✓	✓
575 VΔ; 60 Hz output	9	L2M														○	○
<b>Non-standard voltage and/or frequencies</b>																	
Non-standard winding for vol- tages between 200 and 690 V (voltages outside this range are available on request) <sup>2)</sup>	9	L1Y														✓	✓

- Without additional charge  
 ✓ With additional charge  
 – Not possible

<sup>1)</sup> With order codes **L1A, L1B, L1C, L1D, L1E, L1L, L1R** and **L1U**, a rated voltage range is also specified on the rating plate.

<sup>2)</sup> Plain text must be specified in the order: Voltage, frequency, circuit, required rated output in kW.

# IEC Squirrel-Cage Motors

## Standard motors up to frame size 315 L

### Special versions

Special versions	Voltage code 11th position of the Order No.	Additional identifica- tion code with order code and plain text if required	Motor type frame size														
			56	63	71	80	90	100	112	132	160	180	200	225	250	280	315 S/M
<b>Self-cooled motors without external fan – Aluminum series 1LP7 and 1LP5</b>																	
			<b>1LP7 (aluminum)</b>									<b>1LP5 (alu- minum)</b>					
<b>Voltage at 50 Hz</b>																	
220 VΔ/380 VY (440 VY at 60 Hz) (210 ... 230 VΔ/360 ... 400 VY); 50 Hz output <sup>1)</sup>	9	L1R	✓	✓	✓	✓	✓	✓	✓	✓	✓	✓	✓	✓	✓	✓	
230 VΔ (220 ... 240 VΔ); 50 Hz output <sup>1)</sup>	9	L1E	○	○	○	○	○	○	○	○	○	○	○	○	○	○	
380 VΔ/660 VY (440 VΔ at 60 Hz) (360 ... 400 VΔ/625 ... 695 VY); 50 Hz output <sup>1)</sup>	9	L1L	✓	✓	✓	✓	✓	✓	✓	✓	✓	✓	✓	✓	✓	✓	
415 VY (395 ... 435 VY); 50 Hz output <sup>1)</sup>	9	L1C	✓	✓	✓	✓	✓	✓	✓	✓	✓	✓	✓	✓	✓	✓	
415 VΔ (395 ... 435 VΔ); 50 Hz output <sup>1)</sup>	9	L1D	✓	✓	✓	✓	✓	✓	✓	✓	✓	✓	✓	✓	✓	✓	
400 VY (380 ... 420 VY); 50 Hz output <sup>1)</sup>	9	L1A	○	○	○	○	○	○	○	○	○	○	○	○	○	○	
400 VΔ (380 ... 420 VΔ); 50 Hz output <sup>1)</sup>	9	L1B	○	○	○	○	○	○	○	○	○	○	○	○	○	○	
400 VΔ (460 VΔ at 60 Hz) (380 ... 420 VΔ); 50 Hz output <sup>1)</sup>	9	L1U	○	○	○	○	○	○	○	○	○	○	○	○	○	○	
<b>Voltage at 60 Hz</b>																	
220 VΔ/380 VY; 50 Hz output	9	L2A	✓	✓	✓	✓	✓	✓	✓	✓	✓	✓	✓	✓	✓	✓	
220 VΔ/380 VY; 60 Hz output	9	L2B	✓	✓	✓	✓	✓	✓	✓	✓	✓	✓	✓	✓	✓	✓	
380 VΔ/660 VY; 50 Hz output	9	L2C	✓	✓	✓	✓	✓	✓	✓	✓	✓	✓	✓	✓	✓	✓	
380 VΔ/660 VY; 60 Hz output	9	L2D	✓	✓	✓	✓	✓	✓	✓	✓	✓	✓	✓	✓	✓	✓	
440 VY; 50 Hz output	9	L2Q	✓	✓	✓	✓	✓	✓	✓	✓	✓	✓	✓	✓	✓	✓	
440 VY; 60 Hz output	9	L2W	✓	✓	✓	✓	✓	✓	✓	✓	✓	✓	✓	✓	✓	✓	
440 VΔ; 50 Hz output	9	L2R	✓	✓	✓	✓	✓	✓	✓	✓	✓	✓	✓	✓	✓	✓	
440 VΔ; 60 Hz output	9	L2X	✓	✓	✓	✓	✓	✓	✓	✓	✓	✓	✓	✓	✓	✓	
460 VY; 50 Hz output	9	L2S	✓	✓	✓	✓	✓	✓	✓	✓	✓	✓	✓	✓	✓	✓	
460 VY; 60 Hz output	9	L2E	○	○	○	○	○	○	○	○	○	○	○	○	○	○	
460 VΔ; 50 Hz output	9	L2T	✓	✓	✓	✓	✓	✓	✓	✓	✓	✓	✓	✓	✓	✓	
460 VΔ; 60 Hz output	9	L2F	○	○	○	○	○	○	○	○	○	○	○	○	○	○	
575 VY; 50 Hz output	9	L2U	✓	✓	✓	✓	✓	✓	✓	✓	✓	✓	✓	✓	✓	✓	
575 VY; 60 Hz output	9	L2L	✓	✓	✓	✓	✓	✓	✓	✓	✓	✓	✓	✓	✓	✓	
575 VΔ; 50 Hz output	9	L2V	✓	✓	✓	✓	✓	✓	✓	✓	✓	✓	✓	✓	✓	✓	
575 VΔ; 60 Hz output	9	L2M	✓	✓	✓	✓	✓	✓	✓	✓	✓	✓	✓	✓	✓	✓	
<b>Voltage changeover at 60 Hz</b>																	
230 VYY/460 VY 60 Hz; 50 Hz output, 9 main terminals and electrical design to NEMA	9	L3E	✓	✓	✓	✓	✓	✓	✓	✓	✓	✓	✓	✓	✓	✓	
230 VYY/460 VY 60 Hz; 60 Hz output, 9 main terminals and electrical design to NEMA	9	L3F	✓	✓	✓	✓	✓	✓	✓	✓	✓	✓	✓	✓	✓	✓	
230 VΔΔ/460 VΔ 60 Hz; 50 Hz output, 12 main terminals and electrical design to NEMA	9	L3G	○	○	○	○	○	✓	✓	✓	✓	✓	✓	✓	✓	✓	
230 VΔΔ/460 VΔ 60 Hz; 60 Hz output, 12 main terminals and electrical design to NEMA	9	L3H	○	○	○	○	○	✓	✓	✓	✓	✓	✓	✓	✓	✓	
<b>Non-standard voltage and/or frequencies</b>																	
Non-standard winding for vol- tages between 200 and 690 V (voltages outside this range are available on request) <sup>2)</sup>	9	L1Y •	✓	✓	✓	✓	✓	✓	✓	✓	✓	✓	✓	✓	✓	✓	

For legend and footnotes, see Page 2/75.

# IEC Squirrel-Cage Motors

## Standard motors up to frame size 315 L

### Special versions

Special versions	Voltage code code 11th position of the Order No.	Additional identifica- tion code with order code and plain text if required	Motor type frame size														
			56	63	71	80	90	100	112	132	160	180	200	225	250	280	315 S/M
<b>Self-cooled motors without external fan – Cast-iron series 1LP4</b>																	
												<b>1LP4 (cast-iron)</b>					
<b>Voltage at 50 Hz</b>																	
220 VΔ/380 VY (440 VY at 60 Hz) (210 ... 230 VΔ/360 ... 400 VY); 50 Hz output <sup>1)</sup>	9	L1R														✓	✓
230 VΔ (220 ... 240 VΔ); 50 Hz output <sup>1)</sup>	9	L1E														○	○
380 VΔ/660 VY (440 VΔ at 60 Hz) (360 ... 400 VΔ/625 ... 695 VY); 50 Hz output <sup>1)</sup>	9	L1L														✓	✓
415 VY (395 ... 435 VY); 50 Hz output <sup>1)</sup>	9	L1C														✓	✓
415 VΔ (395 ... 435 VΔ); 50 Hz output <sup>1)</sup>	9	L1D														✓	✓
400 VY (380 ... 420 VY); 50 Hz output <sup>1)</sup>	9	L1A														○	○
400 VΔ (380 ... 420 VΔ); 50 Hz output <sup>1)</sup>	9	L1B														○	○
400 VΔ (460 VΔ at 60 Hz) (380 ... 420 VΔ); 50 Hz output <sup>1)</sup>	9	L1U														○	○
<b>Voltage at 60 Hz</b>																	
220 VΔ/380 VY; 50 Hz output	9	L2A														✓	✓
220 VΔ/380 VY; 60 Hz output	9	L2B														✓	✓
380 VΔ/660 VY; 50 Hz output	9	L2C														✓	✓
380 VΔ/660 VY; 60 Hz output	9	L2D														✓	✓
440 VY; 50 Hz output	9	L2Q														✓	✓
440 VY; 60 Hz output	9	L2W														✓	✓
440 VΔ; 50 Hz output	9	L2R														✓	✓
440 VΔ; 60 Hz output	9	L2X														✓	✓
460 VY; 50 Hz output	9	L2S														✓	✓
460 VY; 60 Hz output	9	L2E														○	○
460 VΔ; 50 Hz output	9	L2T														✓	✓
460 VΔ; 60 Hz output	9	L2F														○	○
575 VY; 50 Hz output	9	L2U														✓	✓
575 VY; 60 Hz output	9	L2L														✓	✓
575 VΔ; 50 Hz output	9	L2V														✓	✓
575 VΔ; 60 Hz output	9	L2M														○	○
<b>Non-standard voltage and/or frequencies</b>																	
Non-standard winding for vol- tages between 200 and 690 V (voltages outside this range are available on request) <sup>2)</sup>	9	L1Y •														✓	✓

- Without additional charge
- ✓ With additional charge
- Not possible
- This order code only determines the price of the version –  
Additional plain text is required.

<sup>1)</sup> With order codes **L1A, L1B, L1C, L1D, L1E, L1L, L1R** and **L1U**, a rated voltage range is also specified on the rating plate.

<sup>2)</sup> Plain text must be specified in the order: Voltage, frequency, circuit, required rated output in kW.

# IEC Squirrel-Cage Motors

## Standard motors up to frame size 315 L

### Special versions

#### Types of construction

Additional order codes for other types of construction or type of construction codes (without **-Z** supplement)

Order codes have been defined for some special types of construction. They are ordered by specifying the code digit **9** for the type of construction in the 12th position of the Order No. and the appropriate order code.

Special versions	Type of construction code 12th position of the Order No.	Additional identification code with order code and plain text if required	Motor type frame size														
			56	63	71	80	90	100	112	132	160	180	200	225	250	280	315
<b>Self-ventilated energy-saving motors with improved efficiency – Aluminum series 1LA7 and 1LA5</b>																	
			<b>1LA7 (aluminum)</b>									<b>1LA5 (aluminum)</b>					
<b>Without flange</b>																	
IM V5 with protective cover <sup>1)</sup>	9	M1F	-	✓	✓	✓	✓	✓	✓	✓	✓	✓	✓	✓	✓	✓	
<b>With flange</b>																	
IM V3 <sup>2)</sup>	9	M1G	-	-	-	-	-	-	-	-	-	-	✓	✓	✓	-	
<b>With standard flange</b>																	
IM V18 with protective cover <sup>1)</sup>	9	M2A	-	✓	✓	✓	✓	✓	✓	✓	✓	✓	-	-	-	-	
<b>With special flange</b>																	
IM V18 with protective cover <sup>1)</sup>	9	M2B	-	✓	✓	✓	✓	✓	✓	✓	✓	✓	-	-	-	-	
IM B34	9	M2C	✓	✓	✓	✓	✓	✓	✓	✓	✓	✓	-	-	-	-	
<b>Self-ventilated energy-saving motors with high efficiency – Aluminum series 1LA9</b>																	
<b>Self-ventilated motors with increased output – Aluminum series 1LA9</b>																	
			<b>1LA9 (aluminum)</b>														
<b>Without flange</b>																	
IM V5 with protective cover <sup>1)</sup>	9	M1F	-	✓	✓	✓	✓	✓	✓	✓	✓	✓	✓	✓	✓	✓	
<b>With flange</b>																	
IM V3	9	M1G	-	-	-	-	-	-	-	-	-	-	✓	✓	-	-	
<b>With standard flange</b>																	
IM V18 with protective cover <sup>1)</sup>	9	M2A	-	✓	✓	✓	✓	✓	✓	✓	✓	✓	-	-	-	-	
<b>With special flange</b>																	
IM V18 with protective cover <sup>1)</sup>	9	M2B	-	✓	✓	✓	✓	✓	✓	✓	✓	✓	-	-	-	-	
IM B34	9	M2C	✓	✓	✓	✓	✓	✓	✓	✓	✓	✓	-	-	-	-	

- ✓ With additional charge  
 – Not possible

<sup>1)</sup> The "Second shaft extension" option, order code **K16** is not possible.

<sup>2)</sup> For frame sizes 180 M to 225 M, the 1LA5 motors can be supplied with two additional eyebolts; state identification code **-Z** and order code **K32**.

# IEC Squirrel-Cage Motors

## Standard motors up to frame size 315 L

### Special versions

	Type of construction code 12th position of the Order No.	Additional identification code with order code and plain text if required	Motor type frame size																
			56	63	71	80	90	100	112	132	160	180	200	225	250	280	315 S/M	315 L 2-pole	4-, 6-, 8-pole
<b>Self-ventilated energy-saving motors with improved efficiency – Cast-iron series 1LA6 and 1LG4</b>																			
													<b>1LA6 (cast-iron)</b>			<b>1LG4 (cast-iron)</b>			
<b>Without flange</b>																			
IM V5 without protective cover <sup>1)</sup>	9	M1D	–	–	–	–	–	–	–	–	–	–	–	–	–	–	–	✓ <sup>2)</sup>	○
IM V6 <sup>1)</sup>	9	M1E	–	–	–	–	–	–	–	–	–	–	–	–	–	–	–	✓ <sup>2)</sup>	○
IM V5 with protective cover <sup>1) 3)</sup>	9	M1F	✓	✓	✓	✓	✓	✓	✓	✓	✓	✓	✓	✓	✓	✓	✓	✓ <sup>2)</sup>	✓
<b>With flange</b>																			
IM V3 <sup>4)</sup>	9	M1G	–	–	–	–	–	–	–	–	–	–	–	–	–	–	–	–	–
<b>With standard flange</b>																			
IM V18 with protective cover <sup>3)</sup>	9	M2A	✓	✓	✓	✓	–	–	–	–	–	–	–	–	–	–	–	–	–
<b>With special flange</b>																			
IM V18 with protective cover <sup>3)</sup>	9	M2B	✓	✓	✓	✓	–	–	–	–	–	–	–	–	–	–	–	–	–
IM B34	9	M2C	✓	✓	✓	✓	–	–	–	–	–	–	–	–	–	–	–	–	–
<b>Self-ventilated motors with increased output – Cast-iron series 1LG4</b>																			
													<b>1LG4 (cast-iron)</b>						
<b>Without flange</b>																			
IM V5 with protective cover <sup>1) 3)</sup>	9	M1F	–	–	–	–	–	–	–	–	–	–	–	–	–	–	–	–	–
<b>With flange</b>																			
IM V3 <sup>4)</sup>	9	M1G	–	–	–	–	–	–	–	–	–	–	–	–	–	–	–	–	–
<b>Self-ventilated energy-saving motors with high efficiency – Cast-iron series 1LG6</b>																			
													<b>1LG6 (cast-iron)</b>						
<b>Without flange</b>																			
IM V5 without protective cover <sup>1)</sup>	9	M1D	–	–	–	–	–	–	–	–	–	–	–	–	–	–	–	✓ <sup>2)</sup>	○
IM V6 <sup>1)</sup>	9	M1E	–	–	–	–	–	–	–	–	–	–	–	–	–	–	–	✓ <sup>2)</sup>	○
IM V5 with protective cover <sup>1) 3)</sup>	9	M1F	✓	✓	✓	✓	✓	✓	✓	✓	✓	✓	✓	✓	✓	✓	✓	✓ <sup>2)</sup>	✓
<b>With flange</b>																			
IM V3 <sup>4)</sup>	9	M1G	–	–	–	–	–	–	–	–	–	–	–	–	–	–	–	–	–
<b>Self-cooled motors without external fan – Aluminum series 1LP7 and 1LP5</b>																			
													<b>1LP7 (aluminum)</b>			<b>1LP5 (aluminum)</b>			
<b>With flange</b>																			
IM V3 <sup>5)</sup>	9	M1G	–	–	–	–	–	–	–	–	–	–	–	–	–	–	–	–	–
<b>Special flange</b>																			
IM B34	9	M2C	✓	✓	✓	✓	✓	✓	✓	✓	✓	✓	–	–	–	–	–	–	–
<b>Self-cooled motors without external fan – Cast-iron series 1LP4</b>																			
													<b>1LP4 (cast-iron)</b>						
<b>Without flange</b>																			
IM V5 without protective cover <sup>1)</sup>	9	M1D	–	–	–	–	–	–	–	–	–	–	–	–	–	–	–	✓ <sup>2)</sup>	○
IM V6 <sup>1)</sup>	9	M1E	–	–	–	–	–	–	–	–	–	–	–	–	–	–	–	✓ <sup>2)</sup>	○
<b>With flange</b>																			
IM V3 <sup>4)</sup>	9	M1G	✓	✓	✓	✓	✓	✓	✓	✓	✓	✓	–	–	–	–	–	–	–

- Without additional charge
- ✓ With additional charge
- Not possible

<sup>1)</sup> If motors of frame sizes 180 M to 315 L are mounted on the wall, it is recommended that the motor feet are supported.

<sup>2)</sup> 60 Hz version is possible on request.

<sup>3)</sup> The "Second shaft extension" option, order code **K16** is not possible.

<sup>4)</sup> 1LG4/1LG6/1LP4 motors of frame sizes 225 S to 315 L are supplied with two screw-in eyebolts in accordance with IM B5, whereby one can be rotated in accordance with IM V1 or IM V3. It is important to note that stress must not be applied perpendicular to the ring plane.

<sup>5)</sup> For frame sizes 180 M to 200 L, the 1LA5 motors can be supplied with two additional eyebolts; state identification code **-Z** and order code **K32**.

# IEC Squirrel-Cage Motors

## Standard motors up to frame size 315 L

### Special versions

#### Options

Options or order codes (supplement **-Z** is required)

Special versions	Additional identification code <b>-Z</b> with order code and plain text if required	Motor type frame size															
		56	63	71	80	90	100	112	132	160	180	200	225	250	280	315	
<b>Self-ventilated energy-saving motors with improved efficiency – Aluminum series 1LA7 and 1LA5</b>																	
		<b>1LA7 (aluminum)</b>						<b>1LA5 (aluminum)</b>									
<b>Motor protection</b>																	
Motor protection with PTC thermistors with 3 embedded temperature sensors for tripping <sup>1)</sup>	<b>A11</b>	✓	✓	✓	✓	✓	✓	✓	✓	✓	✓	✓	✓	✓	✓	✓	
Motor protection with PTC thermistors with 6 embedded temperature sensors for tripping and alarm <sup>1)</sup>	<b>A12</b>	✓	✓	✓	✓	✓	✓	✓	✓	✓	✓	✓	✓	✓	✓	✓	
Motor temperature detection with embedded temperature sensor KTY 84-130 <sup>1)</sup>	<b>A23</b>	✓	✓	✓	✓	✓	✓	✓	✓	✓	✓	✓	✓	✓	✓	✓	
Motor temperature detection with embedded temperature sensors 2 x KTY 84-130 <sup>1)</sup>	<b>A25</b>	✓	✓	✓	✓	✓	✓	✓	✓	✓	✓	✓	✓	✓	✓	✓	
Temperature detectors for tripping <sup>1)</sup>	<b>A31</b>	✓	✓	✓	✓	✓	✓	✓	✓	✓	✓	✓	✓	✓	✓	✓	
Installation of 3 PT 100 resistance thermometers <sup>1)</sup>	<b>A60</b>	–	–	–	–	–	✓	✓	✓	✓	✓	✓	✓	✓	✓	✓	
<b>Motor connection and connection box</b>																	
ECOFAST motor plug Han-Drive 10e for 230 VΔ/400 VY <sup>2)</sup>	<b>G55</b>	✓	✓	✓	✓	✓	✓	✓	✓	✓	–	–	–	–	–	–	
ECOFAST motor plug EMC Han-Drive 10e for 230 VΔ/400 VY <sup>3)</sup>	<b>G56</b>	✓	✓	✓	✓	✓	✓	✓	✓	✓	–	–	–	–	–	–	
Connection box on RHS	<b>K09</b>	–	–	–	✓	✓	✓	✓	✓	✓	✓	✓	✓	✓	✓	✓	
Connection box on LHS	<b>K10</b>	–	–	–	✓	✓	✓	✓	✓	✓	✓	✓	✓	✓	✓	✓	
One cable gland, metal	<b>K54</b>	✓	✓	✓	✓	✓	✓	✓	✓	✓	✓	✓	✓	✓	✓	✓	
Cable gland, maximum configuration	<b>K55</b>	✓	✓	✓	✓	✓	✓	✓	✓	✓	✓	✓	✓	✓	✓	✓	
Rotation of the connection box through 90°, entry from DE	<b>K83</b>	✓	✓	✓	✓	✓	✓	✓	✓	✓	✓	✓	✓	✓	✓	✓	
Rotation of the connection box through 90°, entry from NDE	<b>K84</b>	✓	✓	✓	✓	✓	✓	✓	✓	✓	✓	✓	✓	✓	✓	✓	
Rotation of connection box through 180°	<b>K85</b>	✓	✓	✓	✓	✓	○	○	○	○	✓	✓	✓	✓	✓	✓	
Next larger connection box	<b>L00</b>	–	–	–	–	–	–	–	–	–	–	–	–	✓	✓	✓	
External earthing	<b>L13</b>	✓	✓	✓	✓	✓	✓	✓	✓	✓	✓	✓	✓	✓	✓	✓	
3 cables protruding, 0.5 m long <sup>4)5)</sup>	<b>L44</b>	✓	✓	✓	✓	✓	✓	✓	✓	✓	✓	O. R.	O. R.	O. R.	O. R.	O. R.	
3 cables protruding, 1.5 m long <sup>4)5)</sup>	<b>L45</b>	✓	✓	✓	✓	✓	✓	✓	✓	✓	✓	O. R.	O. R.	O. R.	O. R.	O. R.	
6 cables protruding, 0.5 m long <sup>4)</sup>	<b>L47</b>	✓	✓	✓	✓	✓	✓	✓	✓	✓	✓	O. R.	O. R.	O. R.	O. R.	O. R.	
6 cables protruding, 1.5 m long <sup>4)</sup>	<b>L48</b>	✓	✓	✓	✓	✓	✓	✓	✓	✓	✓	✓	✓	✓	✓	✓	
6 cables protruding, 3 m long <sup>4)</sup>	<b>L49</b>	✓	✓	✓	✓	✓	✓	✓	✓	✓	✓	✓	✓	✓	✓	✓	
Connection box on NDE	<b>M64</b>	–	✓	✓	✓	✓	✓	✓	✓	✓	✓	✓	✓	✓	✓	✓	
Terminal strip for main and auxiliary terminals	<b>M69</b>	–	✓	✓	✓	✓	✓	–	–	–	–	–	–	–	–	–	

For legend, see Page 2/82, for footnotes, see Page 2/83.



# IEC Squirrel-Cage Motors

## Standard motors up to frame size 315 L

### Special versions

Special versions	Additional identification code <b>-Z</b> with order code and plain text if required	Motor type frame size														
		56	63	71	80	90	100	112	132	160	180	200	225	250	280	315
<b>Self-ventilated energy-saving motors with improved efficiency – Aluminum series 1LA7 and 1LA5</b>																
		<b>1LA7 (aluminum)</b>						<b>1LA5 (aluminum)</b>								
<b>Windings and insulation</b>																
Temperature class 155 (F), used acc. to 155 (F), with service factor (SF)	<b>C11</b>	✓	✓	✓	✓	✓	✓	✓	✓	✓	✓	✓	✓	✓	✓	✓
Temperature class 155 (F), used acc. to 155 (F), with increased output	<b>C12</b>	✓	✓	✓	✓	✓	✓	✓	✓	✓	✓	✓	✓	✓	✓	✓
Temperature class 155 (F), used acc. to 155 (F), with increased coolant temperature	<b>C13</b>	✓	✓	✓	✓	✓	✓	✓	✓	✓	✓	✓	✓	✓	✓	✓
Temperature class 180 (H) at rated output and max. CT 60 °C <sup>6)</sup>	<b>C18</b>	✓	✓	✓	✓	✓	✓	✓	✓	✓	✓	✓	✓	✓	✓	✓
Increased air humidity/temperature with 30 to 60 g water per m <sup>3</sup> of air	<b>C19</b>	–	✓	✓	✓	✓	✓	✓	✓	✓	✓	✓	✓	✓	✓	✓
Temperature class 155 (F), used acc. to 130 (B), coolant temperature 45 °C, derating approx. 4 % <sup>7)</sup>	<b>C22</b>	✓	✓	✓	✓	✓	✓	✓	✓	✓	✓	✓	✓	✓	✓	✓
Temperature class 155 (F), used acc. to 130 (B), coolant temperature 50 °C, derating approx. 8 % <sup>7)</sup>	<b>C23</b>	✓	✓	✓	✓	✓	✓	✓	✓	✓	✓	✓	✓	✓	✓	✓
Temperature class 155 (F), used acc. to 130 (B), coolant temperature 55 °C, derating approx. 13 % <sup>7)</sup>	<b>C24</b>	✓	✓	✓	✓	✓	✓	✓	✓	✓	✓	✓	✓	✓	✓	✓
Temperature class 155 (F), used acc. to 130 (B), coolant temperature 60 °C, derating approx. 18 %	<b>C25</b>	✓	✓	✓	✓	✓	✓	✓	✓	✓	✓	✓	✓	✓	✓	✓
Increased air humidity/temperature with 60 to 100 g water per m <sup>3</sup> of air	<b>C26</b>	–	✓	✓	✓	✓	✓	✓	✓	✓	✓	✓	✓	✓	✓	✓
Temperature class 155 (F), used acc. to 130 (B), with increased coolant temperature and/or site altitude	<b>Y50 •</b> and specified output, CT .. °C or SA .... m above sea level	✓	✓	✓	✓	✓	✓	✓	✓	✓	✓	✓	✓	✓	✓	✓
Temperature class 155 (F), used acc. to 155 (F), other requirements	<b>Y52 •</b> and specified output, CT .. °C or SA .... m above sea level	✓	✓	✓	✓	✓	✓	✓	✓	✓	✓	✓	✓	✓	✓	✓
<b>Colors and paint finish</b>																
Special finish in RAL 7030 stone gray		□	□	□	□	□	□	□	□	□	□	□	□	□	□	□
Special finish in other standard RAL colors: RAL 1002, 1013, 1015, 1019, 2003, 2004, 3000, 3007, 5007, 5009, 5010, 5012, 5015, 5017, 5018, 5019, 6011, 6019, 6021, 7000, 7001, 7004, 7011, 7016, 7022, 7031, 7032, 7033, 7035, 9001, 9002, 9005 Page 0/18	<b>Y54 •</b> and special finish RAL ....	✓	✓	✓	✓	✓	✓	✓	✓	✓	✓	✓	✓	✓	✓	✓
Special finish in special RAL colors: For RAL colors, see "Special finish in special RAL colors" on Page 0/19	<b>Y51 •</b> and special finish RAL ....	✓	✓	✓	✓	✓	✓	✓	✓	✓	✓	✓	✓	✓	✓	✓
Sea air resistant special finish	<b>M94</b>	O. R.	O. R.	O. R.	O. R.	O. R.	O. R.	O. R.	O. R.	O. R.	O. R.	O. R.	O. R.	O. R.	O. R.	O. R.

# IEC Squirrel-Cage Motors

## Standard motors up to frame size 315 L

### Special versions

Special versions	Additional identification code <b>-Z</b> with order code and plain text if required	Motor type frame size														
		56	63	71	80	90	100	112	132	160	180	200	225	250	280	315
<b>Self-ventilated energy-saving motors with improved efficiency – Aluminum series 1LA7 and 1LA5</b>																
		<b>1LA7 (aluminum)</b>						<b>1LA5 (aluminum)</b>								
<b>Colors and paint finish (continued)</b>																
Unpainted (only cast iron parts primed)	<b>K23</b>	○	○	○	○	○	○	○	○	○	○	○	○	○	○	○
Unpainted, only primed	<b>K24</b>	✓	✓	✓	✓	✓	✓	✓	✓	✓	✓	✓	✓	✓	✓	✓
<b>Modular technology – Basic versions <sup>8)</sup></b>																
Mounting of separately driven fan	<b>G17</b>	–	–	–	–	–	✓	✓	✓	✓	✓	✓	✓	✓	✓	✓
Mounting of brake <sup>9)</sup>	<b>G26</b>	–	✓	✓	✓	✓	✓	✓	✓	✓	✓	✓	✓	✓	✓	✓
Mounting of 1XP8 001-1 (HTL) rotary pulse encoder	<b>H57</b>	–	–	✓	✓	✓	✓	✓	✓	✓	✓	✓	✓	✓	✓	✓
Mounting of 1XP8 001-2 (TTL) rotary pulse encoder	<b>H58</b>	–	–	✓	✓	✓	✓	✓	✓	✓	✓	✓	✓	✓	✓	✓
<b>Modular technology – Combinations of basic versions <sup>8)</sup></b>																
Mounting of separately driven fan and 1XP8 001-1 rotary pulse encoder	<b>H61</b>	–	–	–	–	–	✓	✓	✓	✓	✓	✓	✓	✓	✓	✓
Mounting of brake and 1XP8 001-1 rotary pulse encoder <sup>9)</sup>	<b>H62</b>	–	–	–	–	–	✓	✓	✓	✓	✓	✓	✓	✓	✓	✓
Mounting of brake and separately driven fan <sup>9)</sup>	<b>H63</b>	–	–	–	–	–	✓	✓	✓	✓	✓	✓	✓	✓	✓	✓
Mounting of brake, separately driven fan and 1XP8 001-1 rotary pulse encoder <sup>9)</sup>	<b>H64</b>	–	–	–	–	–	✓	✓	✓	✓	✓	✓	✓	✓	✓	✓
Mounting of separately driven fan and 1XP8 001-2 rotary pulse encoder	<b>H97</b>	–	–	–	–	–	✓	✓	✓	✓	✓	✓	✓	✓	✓	✓
Mounting of brake and 1XP8 001-2 rotary pulse encoder <sup>9)</sup>	<b>H98</b>	–	–	–	–	–	✓	✓	✓	✓	✓	✓	✓	✓	✓	✓
Mounting of brake, separately driven fan and 1XP8 001-2 rotary pulse encoder <sup>9)</sup>	<b>H99</b>	–	–	–	–	–	✓	✓	✓	✓	✓	✓	✓	✓	✓	✓
<b>Modular technology – Additional versions</b>																
Brake supply voltage 24 V DC	<b>C00</b>	–	✓	✓	✓	✓	✓	✓	✓	✓	✓	✓	✓	✓	✓	✓
Brake supply voltage 400 V AC	<b>C01</b>	–	✓	✓	✓	✓	✓	✓	✓	✓	✓	✓	✓	✓	✓	✓
Brake supply voltage 180 V DC, for operation on MICROMASTER 411-ECOFAS <sup>10)</sup>	<b>C02</b>	–	✓	✓	✓	✓	✓	✓	✓	✓	–	–	–	–	–	–
Mechanical manual brake release with lever (no locking)	<b>K82</b>	–	✓	✓	✓	✓	✓	✓	✓	✓	✓	✓	✓	✓	✓	✓
<b>Special technology <sup>8)</sup></b>																
Prepared for mounting MMI <sup>11)</sup>	<b>H15</b>	O. R.	O. R.	✓	✓	✓	✓	✓	✓	✓	–	–	–	–	–	–
Mounting of LL 861 900 220 rotary pulse encoder	<b>H70</b>	–	–	–	–	–	✓	✓	✓	✓	✓	✓	✓	✓	✓	✓
Mounting of HOG 9 D 1024 I rotary pulse encoder	<b>H72</b>	–	–	–	–	–	✓	✓	✓	✓	✓	✓	✓	✓	✓	✓
Mounting of HOG 10 D 1024 I rotary pulse encoder	<b>H73</b>	–	–	–	–	–	✓	✓	✓	✓	✓	✓	✓	✓	✓	✓
Prepared for mounting LL 861 900 220	<b>H78</b>	–	–	–	–	–	✓	✓	✓	✓	✓	✓	✓	✓	✓	✓
Prepared for mounting HOG 9 D 1024 I	<b>H79</b>	–	–	–	–	–	✓	✓	✓	✓	✓	✓	✓	✓	✓	✓
Prepared for mounting HOG 10 D 1024 I	<b>H80</b>	–	–	–	–	–	✓	✓	✓	✓	✓	✓	✓	✓	✓	✓

For legend, see Page 2/82, for footnotes, see Page 2/83.

# IEC Squirrel-Cage Motors

## Standard motors up to frame size 315 L

### Special versions

Special versions	Additional identification code <b>-Z</b> with order code and plain text if required	Motor type frame size														
		56	63	71	80	90	100	112	132	160	180	200	225	250	280	315
<b>Self-ventilated energy-saving motors with improved efficiency – Aluminum series 1LA7 and 1LA5</b>																
		<b>1LA7 (aluminum)</b>						<b>1LA5 (aluminum)</b>								
<b>Mechanical design and degrees of protection</b>																
Drive-end seal for flange-mounting motors, oil resistant to 0.1 bar <sup>12)</sup>	<b>K17</b>	✓	✓	✓	✓	✓	✓	✓	✓	✓	✓	✓	✓	✓	✓	✓
With two additional eyebolts for IM V1/IM V3	<b>K32</b>	–	–	–	–	–	–	–	–	–	–	–	–	–	–	–
Low-noise version for 2-pole motors with clockwise direction of rotation <sup>10)</sup>	<b>K37</b>	–	–	–	–	–	–	–	–	–	–	–	–	–	–	–
Low-noise version for 2-pole motors with counterclockwise direction of rotation <sup>10)</sup>	<b>K38</b>	–	–	–	–	–	–	–	–	–	–	–	–	–	–	–
IP65 degree of protection <sup>13)</sup>	<b>K50</b>	✓	✓	✓	✓	✓	✓	✓	✓	✓	✓	✓	✓	✓	✓	✓
IP56 degree of protection (non-heavy-sea) <sup>14)</sup>	<b>K52</b>	✓	✓	✓	✓	✓	✓	✓	✓	✓	✓	✓	✓	✓	✓	✓
Vibration-proof version	<b>L03</b>	✓	✓	✓	✓	✓	✓	✓	✓	✓	✓	✓	✓	✓	✓	✓
Condensation drainage holes <sup>15)</sup>	<b>L12</b>	✓	✓	✓	✓	✓	✓	✓	✓	✓	✓	✓	✓	✓	✓	✓
Non-rusting screws (externally)	<b>M27</b>	✓	✓	✓	✓	✓	✓	✓	✓	✓	✓	✓	✓	✓	✓	✓
Mechanical protection for encoder <sup>16)</sup>	<b>M68</b>	–	–	–	–	–	–	–	–	–	–	–	–	–	–	–
<b>Coolant temperature and site altitude</b>																
Coolant temperature –40 to +40 °C	<b>D03</b>	✓	✓	✓	✓	✓	✓	✓	✓	✓	✓	✓	✓	✓	✓	✓
Coolant temperature –30 to +40 °C	<b>D04</b>	✓	✓	✓	✓	✓	✓	✓	✓	✓	✓	✓	✓	✓	✓	✓
<b>Designs in accordance with standards and specifications</b>																
CCC China Compulsory Certification <sup>17)</sup>	<b>D01</b>	✓	✓	✓	✓	✓	–	–	–	–	–	–	–	–	–	–
Electrical according to NEMA MG1-12	<b>D30</b>	✓	✓	✓	✓	✓	✓	✓	✓	✓	✓	✓	✓	✓	✓	✓
Design according to UL with "Recognition Mark" <sup>18)</sup>	<b>D31</b>	✓	✓	✓	✓	✓	✓	✓	✓	✓	✓	✓	✓	✓	✓	✓
Canadian regulations (CSA) <sup>19)</sup>	<b>D40</b>	✓	✓	✓	✓	✓	○	○	○	○	○	○	○	○	○	○
PSE Mark Japan <sup>20)</sup>	<b>D46</b>	✓	✓	✓	✓	✓	✓	✓	✓	–	–	–	–	–	–	–
VIK version (includes Zone 2 for mains-fed operation, without Ex nA II on rating plate) <sup>21)</sup>	<b>K30</b>	–	✓	✓	✓	✓	✓	✓	✓	✓	✓	–	–	–	–	–
<b>Bearings and lubrication</b>																
Measuring nipple for SPM shock pulse measurement for bearing inspection <sup>22)</sup>	<b>G50</b>	–	–	–	–	–	–	–	–	–	–	–	–	–	–	–
Bearing design for increased cantilever forces	<b>K20</b>	–	–	–	–	–	–	–	–	–	–	–	–	–	–	–
Regreasing device <sup>22)</sup>	<b>K40</b>	–	–	–	–	–	–	–	–	–	–	–	–	–	–	–
Located bearing DE	<b>K94</b>	✓	✓	✓	✓	✓	✓	✓	✓	✓	✓	✓	✓	✓	✓	✓
Located bearing NDE	<b>L04</b>	✓	✓	✓	✓	✓	✓	✓	✓	✓	✓	□	□	□	□	□
<b>Balance and vibration quantity</b>																
Vibration quantity A		□	□	□	□	□	□	□	□	□	□	□	□	□	□	□
Vibration quantity B	<b>K02</b>	✓	✓	✓	✓	✓	✓	✓	✓	✓	✓	✓	✓	✓	✓	✓
Full key balancing	<b>L68</b>	✓	✓	✓	✓	✓	✓	✓	✓	✓	✓	✓	✓	✓	✓	✓
Balancing without key	<b>M37</b>	✓	✓	✓	✓	✓	✓	✓	✓	✓	✓	✓	✓	✓	✓	✓

# IEC Squirrel-Cage Motors

## Standard motors up to frame size 315 L

### Special versions

Special versions	Additional identification code <b>-Z</b> with order code and plain text if required	Motor type frame size															
		56	63	71	80	90	100	112	132	160	180	200	225	250	280	315	
<b>Self-ventilated energy-saving motors with improved efficiency – Aluminum series 1LA7 and 1LA5</b>																	
		<b>1LA7 (aluminum)</b>						<b>1LA5 (aluminum)</b>									
<b>Shaft and rotor</b>																	
Concentricity of shaft extension, coaxiality and linear movement in accordance with DIN 42955 Tolerance R for flange-mounting motors <sup>23)</sup>	<b>K04</b>	✓	✓	✓	✓	✓	✓	✓	✓	✓	✓	✓	✓	✓	✓	✓	
Second standard shaft extension	<b>K16</b>	✓	✓	✓	✓	✓	✓	✓	✓	✓	✓	✓	✓	✓	✓	✓	
Shaft extension with standard dimensions without featherkey way	<b>K42</b>	✓	✓	✓	✓	✓	✓	✓	✓	✓	✓	✓	✓	✓	✓	✓	
Concentricity of shaft extension in accordance with DIN 42955 Tolerance R	<b>L39</b>	✓	✓	✓	✓	✓	✓	✓	✓	✓	✓	✓	✓	✓	✓	✓	
Standard shaft made of non-rusting steel	<b>M65</b>	–	–	–	✓	✓	✓	✓	✓	✓	✓	✓	✓	✓	✓	✓	
Non-standard cylindrical shaft extension <sup>24)</sup>	<b>Y55 •</b> and identification code	✓	✓	✓	✓	✓	✓	✓	✓	✓	✓	✓	✓	✓	✓	✓	
<b>Heating and ventilation</b>																	
Fan cover for textile industry	<b>H17</b>	–	–	–	✓	✓	✓	✓	✓	✓	✓	✓	✓	✓	✓	✓	
Metal external fan <sup>25)</sup>	<b>K35</b>	–	✓	✓	✓	✓	✓	✓	✓	✓	✓	✓	✓	✓	✓	✓	
Anti-condensation heaters for 230 V	<b>K45</b>	✓	✓	✓	✓	✓	✓	✓	✓	✓	✓	✓	✓	✓	✓	✓	
Anti-condensation heaters for 115 V	<b>K46</b>	✓	✓	✓	✓	✓	✓	✓	✓	✓	✓	✓	✓	✓	✓	✓	
<b>Rating plate and extra rating plates</b>																	
Second lubricating plate, supplied loose	<b>B06</b>	–	–	–	–	–	✓	✓	✓	✓	✓	✓	✓	✓	✓	✓	
Second rating plate, loose	<b>K31</b>	✓	✓	✓	✓	✓	✓	✓	✓	✓	✓	✓	✓	✓	✓	✓	
Extra rating plate or rating plate with deviating rating plate data	<b>Y80 •</b> and identification code	✓	✓	✓	✓	✓	✓	✓	✓	✓	✓	✓	✓	✓	✓	✓	
Extra rating plate with identification codes	<b>Y82 •</b> and identification code	✓	✓	✓	✓	✓	✓	✓	✓	✓	✓	✓	✓	✓	✓	✓	
Additional information on rating plate and on package label (maximum of 20 characters)	<b>Y84 •</b> and identification code	✓	✓	✓	✓	✓	✓	✓	✓	✓	✓	✓	✓	✓	✓	✓	
<b>Packaging, safety notes and test certificates</b>																	
Without safety and commissioning note. Customer's declaration of renouncement required.	<b>B00</b>	○	○	○	○	○	○	○	○	○	○	○	○	○	○	○	
With one safety and startup guide per box pallet	<b>B01</b>	○	○	○	○	○	○	○	○	○	○	○	○	–	–	–	
Acceptance test certificate 3.1 according to EN 10204	<b>B02</b>	✓	✓	✓	✓	✓	✓	✓	✓	✓	✓	✓	✓	✓	✓	✓	
Operating instructions German/English in print	<b>B23</b>	✓	✓	✓	✓	✓	✓	✓	✓	✓	✓	✓	✓	✓	✓	✓	
Type test with heat run for vertical motors, with acceptance	<b>F83</b>	✓	✓	✓	✓	✓	✓	✓	✓	✓	✓	✓	✓	✓	✓	✓	
Wire-lattice pallet	<b>L99</b>	○	○	○	○	○	○	○	○	○	○	○	○	–	–	–	
Connected in star for dispatch	<b>M32</b>	✓	✓	✓	✓	✓	✓	✓	✓	✓	✓	✓	✓	✓	✓	✓	
Connected in delta for dispatch	<b>M33</b>	✓	✓	✓	✓	✓	✓	✓	✓	✓	✓	✓	✓	✓	✓	✓	

- Standard version
- Without additional charge
- This order code only determines the price of the version – Additional plain text is required.
- . R. On request
- ✓ With additional charge
- Not possible

For footnotes, see Page 2/83.

# IEC Squirrel-Cage Motors

## Standard motors up to frame size 315 L

**Special versions**
**2**

- 1) Evaluation with appropriate tripping unit (see Catalog LV 1) is recommended.
- 2) Not possible for pole-changing motors. Only one sensor (temperature sensor or PTC thermistor) can be connected. Only possibilities are voltage code **1** with voltage of 230 V $\Delta$ /400 VY and special voltage with voltage code **9** and order code **L1U** (400 V $\Delta$ ). The following order codes cannot be used in combination with the ECOFAST plugs, order code **G55**: **A12, C02, C18, D31, D40, G50, H15, H17, H62, H63, H64, H98, H99, K04, K15, K16, K34, K35, K40, K45, K46, K52, K54, K82, L03, L44, L45, L47, L48, L49, L51, L52.**
- 3) Not possible for pole-changing motors. Only one sensor (temperature sensor or PTC thermistor) can be connected. Only possibilities are voltage code **1** with voltage of 230 V $\Delta$ /400 VY and special voltage with voltage code **9** and order code **L1U** (400 V $\Delta$ ). The following order codes cannot be used in combination with the ECOFAST plugs, order code **G56**: **A12, A23, A31, C00, C18, D31, D40, G50, H15, H17, K04, K15, K16, K34, K35, K40, K45, K46, K52, K54, K82, L03, L44, L45, L47, L48, L49, L51, L52.** The following order codes can only be used in combination with the ECOFAST plugs, order code **G56** only with order code **C01** (AC 400 V) or **C02** (DC 180 V): **G26, H62, H63, H64, H98, H99.**
- 4) In combination with the PTC thermistor option or anti-condensation heating option, please inquire before ordering.
- 5) Not possible for pole-changing motors and/or for voltage codes **1** or **6**.
- 6) Cannot be used for motors in UL version (order code **D31**). Cannot be used for motors according to CSA approval (order code **D40**) for motor series 1LA5 frame size 180 to 225. The grease lifetime specified in catalog part 0 "Introduction" refers to CT 40 °C. When the coolant temperature rises by 10 K, the grease lifetime or relubrication interval is halved.
- 7) No derating in combination with the following order codes: **L2A, L2C, L2Q, L2R, L2S, L2T, L2U, L2V, L3E** and **L3G.**
- 8) A second shaft extension is not possible. Please inquire for mounted brakes. The order codes listed cannot be combined within the various technologies nor with each other within the same technology system. This applies for:
  - Modular technology
  - Basic versions of "Modular technology"
  - Combination of special versions "Special technology"
- 9) The standard brake supply voltage is 230 V AC, 50/60 Hz. Other brake supply voltages are possible with order codes **C00, C01** and **C02**.
- 10) Not possible in motors in a pole-changing version.
- 11) Converter mounting is possible, if the MICROMASTER DA 51.3 type is specified for 230 V $\Delta$ /400 VY.
- 12) Not possible for type of construction IM V3.
- 13) Not possible in combination with rotary pulse encoder HOG 9 D 10241 (order code **H72, H79**) and/or brake 2LM8 (used for motors up to and including frame size 225, order code **G26**).
- 14) Not possible in combination with brake 2LM8 (used for motors up to and including frame size 225, order code **G26**).
- 15) Supplied with the condensation drainage holes sealed at the drive end DE and non-drive end NDE (IP55, IP56, IP65). If condensation drainage holes are required in motors of the IM B6, IM B7 or IM B8 type of construction (feet located on side or top), it is necessary to relocate the bearing plates at the drive end (DE) and non-drive end (NDE) so that the condensation drainage holes situated between the feet on delivery are underneath.
- 16) Not necessary when a rotary pulse encoder is combined with a separately driven fan, because in this case the rotary pulse encoder is installed under the fan cowl.
- 17) CCC certification is required for
  - 2-pole motors  $\leq 2.2$  kW
  - 4-pole motors  $\leq 1.1$  kW
  - 6-pole motors  $\leq 0.75$  kW
  - 8-pole motors  $\leq 0.55$  kW
 The order code **D01** for frame sizes 100 and 112 is only valid for pole-changing motors 1LA7.
- 18) Possible up to 600 V max. The rated voltage is indicated on the rating plate without voltage range.
- 19) The rated voltage is indicated on the rating plate without voltage range.
- 20) "Small power motors" with a rated output of up to 3 kW which are exported to Japan must bear the PSE marking.
- 21) Not possible for pole-changing motors.
- 22) Not possible when brake is mounted.
- 23) Can be combined with deep-groove bearings of series 60.., 62.. and 63... Not possible in combination with parallel roller bearings (e.g. bearings for increased cantilever forces, order code **K20**), brake mounting or encoder mounting.
- 24) When motors are ordered that have a longer or shorter shaft extension than normal, the required position and length of the featherkey way must be specified in a sketch. It must be ensured that only featherkeys in accordance with DIN 6885, Form A are permitted to be used. The featherkey way is positioned centrally on the shaft extension. The length is defined by the manufacturer normatively. Not valid for: Conical shafts, non-standard threaded journals, non-standard shaft tolerances, friction welded journals, extremely "thin" shafts, special geometry dimensions (e.g. square journals), hollow shafts. Valid for non-standard shaft extensions DE or NDE. The featherkeys are supplied in every case. For order codes **Y55** and **K16**:
  - Dimensions D and DA  $\leq$  internal diameter of roller bearing (see dimension tables under "Dimensions")
  - Dimensions E and EA  $\leq 2 \times$  length E (normal) of the shaft extension
 For an explanation of the order codes, see catalog part 0 "Introduction".
- 25) For 1LA5/6/7/9 motors and 1LG with metal external fan, converter-fed operation is permitted. The metal external fan is not possible in combination with the low-noise version – order code **K37** or **K38**.

# IEC Squirrel-Cage Motors

## Standard motors up to frame size 315 L

### Special versions

Options or order codes (supplement **-Z** is required)

Special versions	Additional identification code <b>-Z</b> with order code and plain text if required	Motor type frame size														
		56	63	71	80	90	100	112	132	160	180	200	225	250	280	315
<b>Self-ventilated energy-saving motors with high efficiency – Aluminum series 1LA9</b>																
<b>1LA9 (aluminum)</b>																
<b>Motor protection</b>																
Motor protection with PTC thermistors with 3 embedded temperature sensors for tripping <sup>1)</sup>	<b>A11</b>	✓	✓	✓	✓	✓	✓	✓	✓	✓	✓	✓	✓	✓	✓	✓
Motor protection with PTC thermistors with 6 embedded temperature sensors for tripping and alarm <sup>1)</sup>	<b>A12</b>	✓	✓	✓	✓	✓	✓	✓	✓	✓	✓	✓	✓	✓	✓	✓
Motor temperature detection with embedded temperature sensor KTY 84-130 <sup>1)</sup>	<b>A23</b>	✓	✓	✓	✓	✓	✓	✓	✓	✓	✓	✓	✓	✓	✓	✓
Motor temperature detection with embedded temperature sensors 2 x KTY 84-130 <sup>1)</sup>	<b>A25</b>	✓	✓	✓	✓	✓	✓	✓	✓	✓	✓	✓	✓	✓	✓	✓
Temperature detectors for tripping <sup>1)</sup>	<b>A31</b>	✓	✓	✓	✓	✓	✓	✓	✓	✓	✓	✓	✓	✓	✓	✓
Installation of 3 PT 100 resistance thermometers <sup>1)</sup>	<b>A60</b>	-	-	-	-	-	✓	✓	✓	✓	✓	✓	✓	✓	✓	✓
<b>Motor connection and connection box</b>																
ECOFAST motor plug Han-Drive 10e for 230 VΔ/400 VY <sup>2)</sup>	<b>G55</b>	✓	✓	✓	✓	✓	✓	✓	✓	✓	-	-	-	-	-	-
ECOFAST motor plug EMC Han-Drive 10e for 230 VΔ/400VY <sup>3)</sup>	<b>G56</b>	✓	✓	✓	✓	✓	✓	✓	✓	✓	-	-	-	-	-	-
Connection box on RHS	<b>K09</b>	-	-	-	✓	✓	✓	✓	✓	✓	✓	✓	✓	✓	✓	✓
Connection box on LHS	<b>K10</b>	-	-	-	✓	✓	✓	✓	✓	✓	✓	✓	✓	✓	✓	✓
One cable gland, metal	<b>K54</b>	-	-	-	-	-	✓	✓	✓	✓	✓	-	-	-	-	-
Cable gland, maximum configuration	<b>K55</b>	✓	✓	✓	✓	✓	✓	✓	✓	✓	✓	✓	✓	✓	✓	✓
Rotation of the connection box through 90°, entry from DE	<b>K83</b>	✓	✓	✓	✓	✓	✓	✓	✓	✓	✓	✓	✓	✓	✓	✓
Rotation of the connection box through 90°, entry from NDE	<b>K84</b>	✓	✓	✓	✓	✓	✓	✓	✓	✓	✓	✓	✓	✓	✓	✓
Rotation of connection box through 180°	<b>K85</b>	✓	✓	✓	✓	✓	○	○	○	○	○	✓	✓	✓	✓	✓
Next larger connection box	<b>L00</b>	-	-	-	-	-	-	-	-	-	-	✓	✓	✓	✓	✓
External earthing	<b>L13</b>	✓	✓	✓	✓	✓	✓	✓	✓	✓	✓	✓	✓	✓	✓	✓
3 cables protruding, 0.5 m long <sup>4)5)</sup>	<b>L44</b>	✓	✓	✓	✓	✓	✓	✓	✓	✓	✓	✓	✓	✓	O. R.	O. R.
3 cables protruding, 1.5 m long <sup>4)5)</sup>	<b>L45</b>	✓	✓	✓	✓	✓	✓	✓	✓	✓	✓	✓	✓	✓	O. R.	O. R.
6 cables protruding, 0.5 m long <sup>4)</sup>	<b>L47</b>	✓	✓	✓	✓	✓	✓	✓	✓	✓	✓	✓	✓	✓	O. R.	O. R.
6 cables protruding, 1.5 m long <sup>4)</sup>	<b>L48</b>	✓	✓	✓	✓	✓	✓	✓	✓	✓	✓	✓	✓	✓	✓	✓
6 cables protruding, 3 m long <sup>4)</sup>	<b>L49</b>	✓	✓	✓	✓	✓	✓	✓	✓	✓	✓	✓	✓	✓	✓	✓
Connection box on NDE	<b>M64</b>	-	✓	✓	✓	✓	✓	✓	✓	✓	✓	✓	✓	✓	✓	✓
<b>Windings and insulation</b>																
Temperature class 155 (F), used acc. to 155 (F), with service factor (SF)	<b>C11</b>	✓	✓	✓	✓	✓	✓	✓	✓	✓	✓	✓	✓	✓	✓	✓
Temperature class 155 (F), used acc. to 155 (F), with increased output	<b>C12</b>	✓	✓	✓	✓	✓	✓	✓	✓	✓	✓	✓	✓	✓	✓	✓
Temperature class 155 (F), used acc. to 155 (F), with increased coolant temperature	<b>C13</b>	✓	✓	✓	✓	✓	✓	✓	✓	✓	✓	✓	✓	✓	✓	✓
Increased air humidity/temperature with 30 to 60 g water per m <sup>3</sup> of air	<b>C19</b>	-	✓	✓	✓	✓	✓	✓	✓	✓	✓	✓	✓	✓	✓	✓
Temperature class 155 (F), used acc. to 130 (B), coolant temperature 45 °C, derating approx. 4 % <sup>6)</sup>	<b>C22</b>	✓	✓	✓	✓	✓	✓	✓	✓	✓	✓	✓	✓	✓	✓	✓

For legend and footnotes, see Page 2/87.

# IEC Squirrel-Cage Motors

## Standard motors up to frame size 315 L

### Special versions

Special versions	Additional identification code -Z with order code and plain text if required	Motor type frame size														
		56	63	71	80	90	100	112	132	160	180	200	225	250	280	315
<b>Self-ventilated energy-saving motors with high efficiency – Aluminum series 1LA9</b>																
<b>1LA9 (aluminum)</b>																
<b>Windings and insulation (continued)</b>																
Temperature class 155 (F), used acc. to 130 (B), coolant temperature 50 °C, derating approx. 8 % <sup>6)</sup>	<b>C23</b>	✓	✓	✓	✓	✓	✓	✓	✓	✓	✓	✓	✓	✓	✓	✓
Temperature class 155 (F), used acc. to 130 (B), coolant temperature 55 °C, derating approx. 13 % <sup>6)</sup>	<b>C24</b>	✓	✓	✓	✓	✓	✓	✓	✓	✓	✓	✓	✓	✓	✓	✓
Temperature class 155 (F), used acc. to 130 (B), coolant temperature 60 °C, derating approx. 18 %	<b>C25</b>	✓	✓	✓	✓	✓	✓	✓	✓	✓	✓	✓	✓	✓	✓	✓
Increased air humidity/temperature with 60 to 100 g water per m <sup>3</sup> of air	<b>C26</b>	–	✓	✓	✓	✓	✓	✓	✓	✓	✓	✓	✓	✓	✓	✓
Temperature class 155 (F), used acc. to 130 (B), with increased coolant temperature and/or site altitude	<b>Y50 •</b> and specified output, CT... °C or SA .... m above sea level	✓	✓	✓	✓	✓	✓	✓	✓	✓	✓	✓	✓	✓	✓	✓
Temperature class 155 (F), used acc. to 155 (F), other requirements	<b>Y52 •</b> and specified output, CT... °C or SA .... m above sea level	✓	✓	✓	✓	✓	✓	✓	✓	✓	✓	✓	✓	✓	✓	✓
<b>Colors and paint finish</b>																
Special finish in RAL 7030 stone gray		□	□	□	□	□	□	□	□	□	□	□	□	□	□	□
Special finish in other standard RAL colors: RAL 1002, 1013, 1015, 1019, 2003, 2004, 3000, 3007, 5007, 5009, 5010, 5012, 5015, 5017, 5018, 5019, 6011, 6019, 6021, 7000, 7001, 7004, 7011, 7016, 7022, 7031, 7032, 7033, 7035, 9001, 9002, 9005 Page 0/18	<b>Y54 •</b> and special finish RAL ....	✓	✓	✓	✓	✓	✓	✓	✓	✓	✓	✓	✓	✓	✓	✓
Special finish in special RAL colors: For RAL colors, see "Special finish in special RAL colors" on Page 0/19	<b>Y51 •</b> and special finish RAL ....	✓	✓	✓	✓	✓	✓	✓	✓	✓	✓	✓	✓	✓	✓	✓
Sea air resistant special finish	<b>M94</b>	O. R.	O. R.	O. R.	O. R.	O. R.	O. R.	O. R.	O. R.	O. R.	O. R.	O. R.	O. R.	O. R.	O. R.	O. R.
Unpainted (only cast iron parts primed)	<b>K23</b>	○	○	○	○	○	○	○	○	○	○	○	○	○	○	○
Unpainted, only primed	<b>K24</b>	✓	✓	✓	✓	✓	✓	✓	✓	✓	✓	✓	✓	✓	✓	✓
<b>Mechanical design and degrees of protection</b>																
Drive-end seal for flange-mounting motors, oil-resistant to 0,1 bar Not possible for IM V3 type of construction.	<b>K17</b>	✓	✓	✓	✓	✓	✓	✓	✓	✓	✓	✓	✓	✓	✓	✓
Low-noise version for 2-pole motors with clockwise direction of rotation	<b>K37</b>	–	–	–	–	–	–	–	–	–	–	–	–	–	✓	✓
Low-noise version for 2-pole motors with counter-clockwise direction of rotation	<b>K38</b>	–	–	–	–	–	–	–	–	–	–	–	–	–	✓	✓
IP65 degree of protection	<b>K50</b>	✓	✓	✓	✓	✓	✓	✓	✓	✓	✓	✓	✓	✓	✓	✓
IP56 degree of protection (non-heavy-sea)	<b>K52</b>	✓	✓	✓	✓	✓	✓	✓	✓	✓	✓	✓	✓	✓	✓	✓
Vibration-proof version	<b>L03</b>	✓	✓	✓	✓	✓	✓	✓	✓	✓	✓	✓	✓	✓	✓	✓
Condensation drainage holes <sup>7)</sup>	<b>L12</b>	✓	✓	✓	✓	✓	✓	✓	✓	✓	✓	✓	✓	✓	✓	✓
Non-rusting screws (externally)	<b>M27</b>	✓	✓	✓	✓	✓	✓	✓	✓	✓	✓	✓	✓	✓	✓	✓

For legend and footnotes, see Page 2/87.

# IEC Squirrel-Cage Motors

## Standard motors up to frame size 315 L

### Special versions

Special versions	Additional identification code -Z with order code and plain text if required	Motor type frame size														
		56	63	71	80	90	100	112	132	160	180	200	225	250	280	315
<b>Self-ventilated energy-saving motors with high efficiency – Aluminum series 1LA9</b>																
<b>1LA9 (aluminum)</b>																
<b>Coolant temperature and site altitude</b>																
Coolant temperature -40 to +40 °C	<b>D03</b>	-	-	-	✓	✓	✓	✓	✓	✓	✓	-	-			
Coolant temperature -30 to +40 °C	<b>D04</b>	✓	✓	✓	✓	✓	✓	✓	✓	✓	✓	✓	✓			
<b>Designs in accordance with standards and specifications</b>																
CCC China Compulsory Certification <sup>8)</sup>	<b>D01</b>	✓	✓	✓	✓	✓	-	-	-	-	-	-	-			
Electrical according to NEMA MG1-12 <sup>9)</sup>	<b>D30</b>	□	□	□	□	□	□	□	□	□	□	□	□			
Design according to UL with "Recognition Mark" <sup>10)</sup>	<b>D31</b>	✓	✓	✓	✓	✓	✓	✓	✓	✓	✓	✓	✓			
Certified for Korea according to KS C4202 <sup>11)</sup>	<b>D33</b>	-	-	-	✓	✓	✓	✓	✓	✓	✓	✓	✓			
Canadian regulations (CSA) <sup>12)</sup>	<b>D40</b>	✓	✓	✓	✓	✓	✓	✓	✓	✓	✓	✓	✓			
PSE Mark Japan <sup>13)</sup>	<b>D46</b>	✓	✓	✓	✓	✓	✓	✓	✓	-	-	-	-			
VIK version (includes Zone 2 for mains-fed operation, without Ex nA II on rating plate)	<b>K30</b>	-	✓	✓	✓	✓	✓	✓	✓	✓	✓	-	-			
<b>Bearings and lubrication</b>																
Measuring nipple for SPM shock pulse measurement for bearing inspection	<b>G50</b>	-	-	-	-	-	✓	✓	✓	✓	✓	✓	✓			
Bearing design for increased cantilever forces	<b>K20</b>	-	-	-	-	-	✓	✓	✓	✓	✓	✓	✓			
Regreasing device	<b>K40</b>	-	-	-	-	-	✓	✓	✓ <sup>14)</sup>	✓	✓	✓	✓			
Located bearing DE	<b>K94</b>	✓	✓	✓	✓	✓	✓	✓	✓	✓	✓	✓	✓			
Located bearing NDE	<b>L04</b>	✓	✓	✓	✓	✓	✓	✓	✓	✓	□	□	□			
<b>Balance and vibration quantity</b>																
Vibration quantity A		□	□	□	□	□	□	□	□	□	□	□	□			
Vibration quantity B	<b>K02</b>	✓	✓	✓	✓	✓	✓	✓	✓	✓	✓	✓	✓			
Full key balancing	<b>L68</b>	✓	✓	✓	✓	✓	✓	✓	✓	✓	✓	✓	✓			
Balancing without key	<b>M37</b>	✓	✓	✓	✓	✓	✓	✓	✓	✓	✓	✓	✓			
<b>Shaft and rotor</b>																
Concentricity of shaft extension, coaxiality and linear movement in accordance with DIN 42955 Tolerance R for flange-mounting motors <sup>15)</sup>	<b>K04</b>	✓	✓	✓	✓	✓	✓	✓	✓	✓	✓	✓	✓			
Second standard shaft extension	<b>K16</b>	✓	✓	✓	✓	✓	✓	✓	✓	✓	✓	✓	✓			
Shaft extension with normal dimensions without featherkey way	<b>K42</b>	✓	✓	✓	✓	✓	✓	✓	✓	✓	✓	✓	✓			
Concentricity of shaft extension in accordance with DIN 42955 Tolerance R	<b>L39</b>	✓	✓	✓	✓	✓	✓	✓	✓	✓	✓	✓	✓			
Non-standard cylindrical shaft extension <sup>16)</sup>	<b>Y55 • and identification code</b>	✓	✓	✓	✓	✓	✓	✓	✓	✓	✓	✓	✓			
<b>Heating and ventilation</b>																
Fan cover for textile industry	<b>H17</b>	-	-	-	-	-	-	✓	✓	-	-	-	-			
Metal external fan <sup>17)</sup>	<b>K35</b>	-	✓	✓	✓	✓	✓	✓	✓	✓	✓	✓	✓			
Anti-condensation heaters for 230 V	<b>K45</b>	✓	✓	✓	✓	✓	✓	✓	✓	✓	✓	✓	✓			
Anti-condensation heaters for 115 V	<b>K46</b>	✓	✓	✓	✓	✓	✓	✓	✓	✓	✓	✓	✓			
<b>Rating plate and extra rating plates</b>																
Second lubricating plate, supplied loose	<b>B06</b>	-	-	-	-	-	✓	✓	✓	✓	✓	✓	✓			
Second rating plate, loose	<b>K31</b>	✓	✓	✓	✓	✓	✓	✓	✓	✓	✓	✓	✓			
Extra rating plate or rating plate with deviating rating plate data	<b>Y80 • and identification code</b>	✓	✓	✓	✓	✓	✓	✓	✓	✓	✓	✓	✓			
Extra rating plate with identification codes	<b>Y82 • and identification code</b>	✓	✓	✓	✓	✓	✓	✓	✓	✓	✓	✓	✓			
Additional information on rating plate and on package label (maximum of 20 characters)	<b>Y84 • and identification code</b>	✓	✓	✓	✓	✓	✓	✓	✓	✓	✓	✓	✓			

For legend and footnotes, see Page 2/87.



# IEC Squirrel-Cage Motors

## Standard motors up to frame size 315 L

### Special versions

Special versions	Additional identification code -Z with order code and plain text if required	Motor type frame size															
		56	63	71	80	90	100	112	132	160	180	200	225	250	280	315	
<b>Self-ventilated energy-saving motors with high efficiency – Aluminum series 1LA9</b>																	
		<b>1LA9 (aluminum)</b>															
<b>Packaging, safety notes, documentation and test certificates</b>																	
Without safety and commissioning note. Customer's declaration of renouncement required.	<b>B00</b>	○	○	○	○	○	○	○	○	○	○	○	○	○	○	○	○
With one safety and startup guide per box pallet	<b>B01</b>	○	○	○	○	○	○	○	○	○	○	○	○	○	○	○	○
Acceptance test certificate 3.1 according to EN 10204	<b>B02</b>	✓	✓	✓	✓	✓	✓	✓	✓	✓	✓	✓	✓	✓	✓	✓	✓
Operating instructions German/English in print	<b>B23</b>	✓	✓	✓	✓	✓	✓	✓	✓	✓	✓	✓	✓	✓	✓	✓	✓
Type test with heat run for vertical motors, with acceptance	<b>F83</b>	✓	✓	✓	✓	✓	✓	✓	✓	✓	✓	✓	✓	✓	✓	✓	✓
Wire-lattice pallet	<b>L99</b>	○	○	○	○	○	○	○	○	○	○	○	○	○	○	○	○
Connected in star for dispatch	<b>M32</b>	✓	✓	✓	✓	✓	✓	✓	✓	✓	✓	✓	✓	✓	✓	✓	✓
Connected in delta for dispatch	<b>M33</b>	✓	✓	✓	✓	✓	✓	✓	✓	✓	✓	✓	✓	✓	✓	✓	✓

- Standard version
- Without additional charge
- This order code only determines the price of the version – Additional plain text is required.
- R. Possible on request
- ✓ With additional charge
- Not possible

- 1) Evaluation with appropriate tripping unit (see Catalog LV 1) is recommended.
- 2) Only one sensor (temperature sensor or PTC thermistor) can be connected. Only possibilities are voltage code **1** with voltage of 230 VΔ/400 VY and special voltage with voltage code **9** and order code **L1U** (400 VΔ). The following order codes cannot be used in combination with the ECOFAST plugs, order code **G55: A12, C02, C18, D31, D40, G26, G50, H15, H17, H62, H63, H64, H98, H99, K04, K15, K16, K34, K35, K40, K45, K46, K52, K54, K82, L03, L44, L45, L47, L48, L49, L51, L52.**
- 3) Only one sensor (temperature sensor or PTC thermistor) can be connected. Only possibilities are voltage code **1** with voltage of 230 VΔ/400 VY and special voltage with voltage code **9** and order code **L1U** (400 VΔ). The following order codes cannot be used in combination with the ECOFAST plugs, order codes **G56: A12, A23, A31, D31, D40, G50, H17, K04, K15, K16, K34, K35, K40, K45, K46, K52, K54, L03, L44, L45, L47, L48, L49, L51, L52.**
- 4) In combination with the PTC thermistor option or anti-condensation heating option, please inquire before ordering.
- 5) Not possible for voltage code **1** or **6**.
- 6) No derating in combination with the following order codes: **L2A, L2C, L2Q, L2R, L2S, L2T, L2U, L2V, L3E** and **L3G**.
- 7) Supplied with the condensation drainage holes sealed at the drive end DE and non-drive end NDE for IP55, IP56 and IP65 degrees of protection. If condensation drainage holes are required in motors of the IM B6, IM B7 or IM B8 type of construction (feet located on side or top), it is necessary to relocate the bearing plates at the drive end (DE) and non-drive end (NDE) so that the condensation drainage holes situated between the feet on delivery are underneath.
- 8) CCC certification is required for
  - 2-pole motors ≤2.2 kW
  - 4-pole motors ≤1.1 kW
  - 6-pole motors ≤0.75 kW
  - 8-pole motors ≤0.55 kW
- 9) Possible up to 600 V max. For EPACT version or UL standard version (no order code necessary). The rated voltage is indicated on the rating plate without voltage range.
- 10) Possible up to 600 V max. The rated voltage is indicated on the rating plate without voltage range.
- 11) For Korea are certified:
  - 2-pole motors ≤0.75 kW
  - 4-pole motors ≤0.75 kW
  - 6-pole motors ≤0.75 kW
- 12) The rated voltage is indicated on the rating plate without voltage range.
- 13) "Small power motors" with a rated output of up to 3 kW which are exported to Japan must bear the PSE marking.
- 14) Not possible for 1LA9 134-6. □□.
- 15) Can be combined with deep-groove bearings of series 60..., 62... and 63... Not possible in combination with parallel roller bearings (e.g. bearings for increased cantilever forces, order code **K20**), brake mounting or encoder mounting.
- 16) When motors are ordered that have a longer or shorter shaft extension than normal, the required position and length of the featherkey way must be specified in a sketch. It must be ensured that only featherkeys in accordance with DIN 6885, Form A are permitted to be used. The featherkey way is positioned centrally on the shaft extension. The length is defined by the manufacturer normatively. Not valid for: Conical shafts, non-standard threaded journals, non-standard shaft tolerances, friction welded journals, extremely "thin" shafts, special geometry dimensions (e.g. square journals), hollow shafts. Valid for non-standard shaft extensions DE or NDE. The featherkeys are supplied in every case. For order codes **Y55** and **K16**:
  - Dimensions D and DA ≤ internal diameter of roller bearing (see dimension tables under "Dimensions")
  - Dimensions E and EA ≤2 x length E (normal) of the shaft extension (for an explanation of the order codes, see catalog part 0 "Introduction").
- 17) For 1LA5/6/7/9 motors and 1LG with metal external fan, converter-fed operation is permitted. The metal external fan is already included (standard version) in combination with the low-noise version.



# IEC Squirrel-Cage Motors

## Standard motors up to frame size 315 L

### Special versions

Options or order codes (supplement **-Z** is required)

Special versions	Additional identification code <b>-Z</b> with order code and plain text if required	Motor type frame size														
		56	63	71	80	90	100	112	132	160	180	200	225	250	280	315
<b>Self-ventilated motors with increased output – Aluminum series 1LA9</b>																
<b>1LA9 (aluminum)</b>																
<b>Motor protection</b>																
Motor protection with PTC thermistors with 3 embedded temperature sensors for tripping <sup>1)</sup>	<b>A11</b>	✓	✓	✓	✓	✓	✓	✓	✓	✓	✓	✓	✓	✓	✓	✓
Motor protection with PTC thermistors with 6 embedded temperature sensors for tripping and alarm <sup>1)</sup>	<b>A12</b>	✓	✓	✓	✓	✓	✓	✓	✓	✓	✓	✓	✓	✓	✓	✓
Motor temperature detection with embedded temperature sensor KTY 84-130 <sup>1)</sup>	<b>A23</b>	✓	✓	✓	✓	✓	✓	✓	✓	✓	✓	✓	✓	✓	✓	✓
Motor temperature detection with embedded temperature sensors 2 x KTY 84-130 <sup>1)</sup>	<b>A25</b>	✓	✓	✓	✓	✓	✓	✓	✓	✓	✓	✓	✓	✓	✓	✓
Temperature detectors for tripping <sup>1)</sup>	<b>A31</b>	✓	✓	✓	✓	✓	✓	✓	✓	✓	✓	✓	✓	✓	✓	✓
Installation of 3 PT 100 resistance thermometers <sup>1)</sup>	<b>A60</b>	–	–	–	–	–	✓	✓	✓	✓	✓	✓	✓	✓	✓	✓
<b>Motor connection and connection box</b>																
ECOFAST motor plug Han-Drive 10e for 230 VΔ/400 VY <sup>2)</sup>	<b>G55</b>	✓	✓	✓	✓	✓	✓	✓	–	–	–	–	–	–	–	–
Connection box on RHS	<b>K09</b>	–	–	–	✓	✓	✓	✓	✓	✓	✓	✓	✓	✓	✓	✓
Connection box on LHS	<b>K10</b>	–	–	–	✓	✓	✓	✓	✓	✓	✓	✓	✓	✓	✓	✓
One cable gland, metal	<b>K54</b>	–	–	–	–	–	✓	✓	✓	✓	✓	✓	–	–	–	–
Cable gland, maximum configuration	<b>K55</b>	✓	✓	✓	✓	✓	✓	✓	✓	✓	✓	✓	✓	✓	✓	✓
Rotation of the connection box through 90°, entry from DE	<b>K83</b>	✓	✓	✓	✓	✓	✓	✓	✓	✓	✓	✓	✓	✓	✓	✓
Rotation of the connection box through 90°, entry from NDE	<b>K84</b>	✓	✓	✓	✓	✓	✓	✓	✓	✓	✓	✓	✓	✓	✓	✓
Rotation of connection box through 180°	<b>K85</b>	✓	✓	✓	✓	✓	○	○	○	○	○	○	✓	✓	✓	✓
Next larger connection box	<b>L00</b>	–	–	–	–	–	–	–	–	–	–	–	✓	✓	✓	✓
External earthing	<b>L13</b>	✓	✓	✓	✓	✓	✓	✓	✓	✓	✓	✓	✓	✓	✓	✓
3 cables protruding, 0.5 m long <sup>3)4)</sup>	<b>L44</b>	✓	✓	✓	✓	✓	✓	✓	✓	✓	✓	✓	✓	O. R.	O. R.	–
3 cables protruding, 1.5 m long <sup>3)4)</sup>	<b>L45</b>	✓	✓	✓	✓	✓	✓	✓	✓	✓	✓	✓	✓	O. R.	O. R.	–
6 cables protruding, 0.5 m long <sup>3)</sup>	<b>L47</b>	✓	✓	✓	✓	✓	✓	✓	✓	✓	✓	✓	✓	O. R.	O. R.	–
6 cables protruding, 1.5 m long <sup>3)</sup>	<b>L48</b>	✓	✓	✓	✓	✓	✓	✓	✓	✓	✓	✓	✓	✓	✓	✓
6 cables protruding, 3 m long <sup>3)</sup>	<b>L49</b>	✓	✓	✓	✓	✓	✓	✓	✓	✓	✓	✓	✓	✓	✓	✓
Connection box on NDE	<b>M64</b>	–	✓	✓	✓	✓	✓	✓	✓	✓	✓	✓	✓	✓	✓	✓
<b>Windings and insulation</b>																
Increased air humidity/temperature with 30 to 60 g water per m <sup>3</sup> of air	<b>C19</b>	–	✓	✓	✓	✓	✓	✓	✓	✓	✓	✓	✓	✓	✓	✓
Increased air humidity/temperature with 60 to 100 g water per m <sup>3</sup> of air	<b>C26</b>	–	✓	✓	✓	✓	✓	✓	✓	✓	✓	✓	✓	✓	✓	✓

For legend, see Page 2/90, for footnotes, see Page 2/91.

# IEC Squirrel-Cage Motors

## Standard motors up to frame size 315 L

### Special versions

Special versions	Additional identification code -Z with order code and plain text if required	Motor type frame size														
		56	63	71	80	90	100	112	132	160	180	200	225	250	280	315
<b>Self-ventilated motors with increased output – Aluminum series 1LA9</b>																
<b>1LA9 (aluminum)</b>																
<b>Colors and paint finish</b>																
Special finish in RAL 7030 stone gray		□	□	□	□	□	□	□	□	□	□	□	□	□	□	□
Special finish in other standard RAL colors: RAL 1002, 1013, 1015, 1019, 2003, 2004, 3000, 3007, 5007, 5009, 5010, 5012, 5015, 5017, 5018, 5019, 6011, 6019, 6021, 7000, 7001, 7004, 7011, 7016, 7022, 7031, 7032, 7033, 7035, 9001, 9002, 9005 Page 0/18	Y54 • and special finish RAL ....	✓	✓	✓	✓	✓	✓	✓	✓	✓	✓	✓	✓	✓	✓	✓
Special finish in special RAL colors: For RAL colors, see "Special finish in special RAL colors" on Page 0/19	Y51 • and special finish RAL ....	✓	✓	✓	✓	✓	✓	✓	✓	✓	✓	✓	✓	✓	✓	✓
Sea air resistant special finish	M94	O. R.	O. R.	O. R.	O. R.	O. R.	O. R.	O. R.	O. R.	O. R.	O. R.	O. R.	O. R.	O. R.	O. R.	O. R.
Unpainted (only cast iron parts primed)	K23	○	○	○	○	○	○	○	○	○	○	○	○	○	○	○
Unpainted, only primed	K24	✓	✓	✓	✓	✓	✓	✓	✓	✓	✓	✓	✓	✓	✓	✓
<b>Mechanical design and degrees of protection</b>																
Drive-end seal for flange-mounting motors with an oil-tightness of up to 0.1 bar Not possible for IM V3 type of construction.	K17	✓	✓	✓	✓	✓	✓	✓	✓	✓	✓	✓	✓	✓	✓	✓
Low-noise version for 2-pole motors with clockwise direction of rotation	K37	-	-	-	-	-	-	-	-	-	-	-	-	✓	✓	✓
Low-noise version for 2-pole motors with counter-clockwise direction of rotation	K38	-	-	-	-	-	-	-	-	-	-	-	-	✓	✓	✓
IP65 degree of protection	K50	✓	✓	✓	✓	✓	✓	✓	✓	✓	✓	✓	✓	✓	✓	✓
IP56 degree of protection (non-heavy-sea)	K52	✓	✓	✓	✓	✓	✓	✓	✓	✓	✓	✓	✓	✓	✓	✓
Vibration-proof version	L03	✓	✓	✓	✓	✓	✓	✓	✓	✓	✓	✓	✓	✓	✓	✓
Condensation drainage holes	L12	✓	✓	✓	✓	✓	✓	✓	✓	✓	✓	✓	✓	✓	✓	✓
Non-rusting screws (externally)	M27	✓	✓	✓	✓	✓	✓	✓	✓	✓	✓	✓	✓	✓	✓	✓
<b>Coolant temperature and site altitude</b>																
Coolant temperature -40 to +40 °C	D03	-	-	-	✓	✓	✓	✓	✓	✓	✓	✓	✓	-	-	-
Coolant temperature -30 to +40 °C	D04	✓	✓	✓	✓	✓	✓	✓	✓	✓	✓	✓	✓	✓	✓	✓
<b>Designs in accordance with standards and specifications</b>																
CCC China Compulsory Certification <sup>5)</sup>	D01	✓	✓	✓	✓	✓	-	-	-	-	-	-	-	-	-	-
Electrical according to NEMA MG1-12 <sup>6)</sup>	D30	✓	✓	✓	✓	✓	✓	✓	✓	✓	✓	✓	✓	✓	✓	✓
Design according to UL with "Recognition Mark" <sup>7)</sup>	D31	✓	✓	✓	✓	✓	✓	✓	✓	✓	✓	✓	✓	✓	✓	✓
Canadian regulations (CSA) <sup>8)</sup>	D40	✓	✓	✓	✓	✓	✓	✓	✓	✓	✓	✓	✓	✓	✓	✓
PSE Mark Japan <sup>9)</sup>	D46	✓	✓	✓	✓	✓	✓	✓	✓	✓	✓	-	-	-	-	-
<b>Bearings and lubrication</b>																
Measuring nipple for SPM shock pulse measurement for bearing inspection	G50	-	-	-	-	-	✓	✓	✓	✓	✓	✓	✓	✓	✓	✓
Bearing design for increased cantilever forces	K20	-	-	-	-	-	✓	✓	✓	✓	✓	✓	✓	✓	✓	✓
Regreasing device	K40	-	-	-	-	-	✓	✓	✓	✓	✓	✓	✓	✓	✓	✓
Located bearing DE	K94	✓	✓	✓	✓	✓	✓	✓	✓	✓	✓	✓	✓	✓	✓	✓
Located bearing NDE	L04	✓	✓	✓	✓	✓	✓	✓	✓	✓	✓	□	□	□	□	□
<b>Balance and vibration quantity</b>																
Vibration quantity A		□	□	□	□	□	□	□	□	□	□	□	□	□	□	□
Full key balancing	L68	✓	✓	✓	✓	✓	✓	✓	✓	✓	✓	✓	✓	✓	✓	✓
Balancing without key	M37	✓	✓	✓	✓	✓	✓	✓	✓	✓	✓	✓	✓	✓	✓	✓

For legend, see Page 2/90, for footnotes, see Page 2/91.

# IEC Squirrel-Cage Motors

## Standard motors up to frame size 315 L

### Special versions

Special versions	Additional identification code -Z with order code and plain text if required	Motor type frame size														
		56	63	71	80	90	100	112	132	160	180	200	225	250	280	315
<b>Self-ventilated motors with increased output – Aluminum series 1LA9</b>																
<b>1LA9 (aluminum)</b>																
<b>Shaft and rotor</b>																
Concentricity of shaft extension, coaxiality and linear movement in accordance with DIN 42955 Tolerance R for flange-mounting motors <sup>10)</sup>	<b>K04</b>	✓	✓	✓	✓	✓	✓	✓	✓	✓	✓	✓	✓	✓	✓	✓
Second standard shaft extension	<b>K16</b>	✓	✓	✓	✓	✓	✓	✓	✓	✓	✓	✓	✓	✓	✓	✓
Shaft extension with normal dimensions without featherkey way	<b>K42</b>	✓	✓	✓	✓	✓	✓	✓	✓	✓	✓	✓	✓	✓	✓	✓
Concentricity of shaft extension in accordance with DIN 42955 Tolerance R	<b>L39</b>	✓	✓	✓	✓	✓	✓	✓	✓	✓	✓	✓	✓	✓	✓	✓
Non-standard cylindrical shaft extension <sup>11)</sup>	<b>Y55 •</b> and identification code	✓	✓	✓	✓	✓	✓	✓	✓	✓	✓	✓	✓	✓	✓	✓
<b>Heating and ventilation</b>																
Fan cover for textile industry	<b>H17</b>	–	–	–	–	–	–	–	✓	✓	–	–	–	–	–	–
Metal external fan <sup>12)</sup>	<b>K35</b>	–	✓	✓	✓	✓	✓	✓	✓	✓	✓	✓	✓	✓	✓	✓
Anti-condensation heaters for 230 V	<b>K45</b>	✓	✓	✓	✓	✓	✓	✓	✓	✓	✓	✓	✓	✓	✓	✓
Anti-condensation heaters for 115 V	<b>K46</b>	✓	✓	✓	✓	✓	✓	✓	✓	✓	✓	✓	✓	✓	✓	✓
<b>Rating plate and extra rating plates</b>																
Second lubricating plate, supplied loose	<b>B06</b>	–	–	–	–	–	–	–	✓	✓	✓	✓	✓	✓	✓	✓
Second rating plate, loose	<b>K31</b>	✓	✓	✓	✓	✓	✓	✓	✓	✓	✓	✓	✓	✓	✓	✓
Extra rating plate or rating plate with deviating rating plate data	<b>Y80 •</b> and identification code	✓	✓	✓	✓	✓	✓	✓	✓	✓	✓	✓	✓	✓	✓	✓
Extra rating plate with identification codes	<b>Y82 •</b> and identification code	✓	✓	✓	✓	✓	✓	✓	✓	✓	✓	✓	✓	✓	✓	✓
Additional information on rating plate and on package label (maximum of 20 characters)	<b>Y84 •</b> and identification code	✓	✓	✓	✓	✓	✓	✓	✓	✓	✓	✓	✓	✓	✓	✓
<b>Packaging, safety notes, documentation and test certificates</b>																
Without safety and commissioning note. Customer's declaration of renouncement required.	<b>B00</b>	○	○	○	○	○	○	○	○	○	○	○	○	○	○	○
With one safety and startup guide per box pallet	<b>B01</b>	○	○	○	○	○	○	○	○	○	○	○	○	○	○	–
Acceptance test certificate 3.1 according to EN 10204	<b>B02</b>	✓	✓	✓	✓	✓	✓	✓	✓	✓	✓	✓	✓	✓	✓	✓
Operating instructions German/English in print	<b>B23</b>	✓	✓	✓	✓	✓	✓	✓	✓	✓	✓	✓	✓	✓	✓	✓
Type test with heat run for vertical motors, with acceptance	<b>F83</b>	✓	✓	✓	✓	✓	✓	✓	✓	✓	✓	✓	✓	✓	✓	✓
Wire-lattice pallet	<b>L99</b>	○	○	○	○	○	○	○	○	○	○	○	○	○	○	–
Connected in star for dispatch	<b>M32</b>	✓	✓	✓	✓	✓	✓	✓	✓	✓	✓	✓	✓	✓	✓	✓
Connected in delta for dispatch	<b>M33</b>	✓	✓	✓	✓	✓	✓	✓	✓	✓	✓	✓	✓	✓	✓	✓

- Standard version
- Without additional charge
- This order code only determines the price of the version – Additional plain text is required.
- . R. Possible on request
- ✓ With additional charge
- Not possible

For footnotes, see Page 2/91.

# IEC Squirrel-Cage Motors

## Standard motors up to frame size 315 L

**Special versions**
**2**

- 1) Evaluation with appropriate tripping unit (see Catalog LV 1) is recommended.
- 2) Only one sensor (temperature sensor or PTC thermistor) can be connected. Only possibilities are voltage code **1** with voltage of 230 VΔ/400 VY and special voltage with voltage code and order code **L1U** (400 VΔ). The following order codes cannot be used in combination with the ECOFAST plugs, order code **G55: A12, C02, C18, D31, D40, G26, G50, H15, H17, H62, H63, H64, H98, H99, K04, K15, K16, K34, K35, K40, K45, K46, K52, K54, K82, L03, L44, L45, L47, L48, L49, L51, L52.**
- 3) In combination with the PTC thermistor option or anti-condensation heating option, please inquire before ordering.
- 4) Not possible for voltage codes **1** or **6**.
- 5) CCC certification is required for
  - 2-pole motors  $\leq 2.2$  kW
  - 4-pole motors  $\leq 1.1$  kW
  - 6-pole motors  $\leq 0.75$  kW
  - 8-pole motors  $\leq 0.55$  kW
- 6) Possible up to 600 V max. For EPACT version or UL standard version (no order code necessary).
- 7) Possible up to 600 V max. The rated voltage is indicated on the rating plate without voltage range.
- 8) The rated voltage is indicated on the rating plate without voltage range.
- 9) "Small power motors" with a rated output of up to 3 kW which are exported to Japan must bear the PSE marking.
- 10) Can be combined with deep-groove bearings of series 60... 62... and 63... Not possible in combination with parallel roller bearings (e.g. bearings for increased cantilever forces, order code **K20**), brake mounting or encoder mounting.
- 11) When motors are ordered that have a longer or shorter shaft extension than normal, the required position and length of the featherkey way must be specified in a sketch. It must be ensured that only featherkeys in accordance with DIN 6885, Form A are permitted to be used. The featherkey way is positioned centrally on the shaft extension. The length is defined by the manufacturer normatively. Not valid for: Conical shafts, non-standard threaded journals, non-standard shaft tolerances, friction welded journals, extremely "thin" shafts, special geometry dimensions (e.g. square journals), hollow shafts. Valid for non-standard shaft extensions DE or NDE. The featherkeys are supplied in every case. For order codes **Y55** and **K16**:
  - Dimensions D and DA  $\leq$  internal diameter of roller bearing (see dimension tables under "Dimensions")
  - Dimensions E and EA  $\leq 2 \times$  length E (normal) of the shaft extension
 For an explanation of the order codes, see catalog part 0 "Introduction".
- 12) For 1LA5/6/7/9 motors and 1LG with metal external fan, converter-fed operation is permitted. The metal external fan is not possible in combination with the low-noise version – order code **K37** or **K38**.

# IEC Squirrel-Cage Motors

## Standard motors up to frame size 315 L

### Special versions

Options or order codes (supplement **-Z** is required)

Special versions	Additional identification code <b>-Z</b> with order code and plain text if required	Motor type frame size														
		56	63	71	80	90	100	112	132	160	180	200	225	250	280	315
<b>Self-ventilated energy-saving motors with improved efficiency – Cast-iron series 1LA6 and 1LG4</b>																
<b>Motor protection</b>																
Motor protection with PTC thermistors with 3 embedded temperature sensors for tripping <sup>1)</sup>	<b>A11</b>															
Motor protection with PTC thermistors with 6 embedded temperature sensors for tripping and alarm <sup>1)</sup>	<b>A12</b>															
Motor temperature detection with embedded temperature sensor KTY 84-130 <sup>1)</sup>	<b>A23</b>															
Motor temperature detection with embedded temperature sensors 2 x KTY 84-130 <sup>1)</sup>	<b>A25</b>															
Temperature detectors for tripping <sup>1)</sup>	<b>A31</b>															
Installation of 3 PT 100 resistance thermometers <sup>1)</sup>	<b>A60</b>															
Installation of 6 PT 100 resistance thermometers in stator winding <sup>1)</sup>	<b>A61</b>															
Installation of 2 PT 100 screw-in resistance thermometers (basic circuit) for rolling-contact bearings <sup>1)</sup>	<b>A72</b>															
Installation of 2 PT 100 screw-in resistance thermometers (3-wire circuit) for rolling-contact bearings <sup>1)</sup>	<b>A78</b>															
Installation of 2 PT 100 double screw-in resistance thermometers (3-wire circuit) for rolling-contact bearings <sup>1)</sup>	<b>A80</b>															
<b>Motor connection and connection box</b>																
Two-part plate on connection box	<b>K06</b>															
Connection box on RHS	<b>K09</b>															
Connection box on LHS	<b>K10</b>															
Connection box on top, feet screwed on	<b>K11</b>															
Connection box in cast-iron version	<b>K15</b>															
One cable gland, metal	<b>K54</b>															
Cable gland, maximum configuration	<b>K55</b>															
Rotation of the connection box through 90°, entry from DE	<b>K83</b>															
Rotation of the connection box through 90°, entry from NDE	<b>K84</b>															
Rotation of connection box through 180°	<b>K85</b>															
Next larger connection box	<b>L00</b>															
External earthing	<b>L13</b>															

For legend, see Page 2/97, for footnotes, see Page 2/98.

# IEC Squirrel-Cage Motors

## Standard motors up to frame size 315 L

### Special versions

Special versions	Additional identification code <b>-Z</b> with order code and plain text if required	Motor type frame size														
		56	63	71	80	90	100	112	132	160	180	200	225	250	280	315
<b>Self-ventilated energy-saving motors with improved efficiency – Cast-iron series 1LA6 and 1LG4</b>																
<b>Motor connection and connection box (continued)</b>																
Undrilled entry plate	<b>L01</b>											○	○	○	○	○
6 cables protruding, 1.5 m long <sup>2)</sup>	<b>L48</b>											✓	✓	✓	O. R.	O. R.
6 cables protruding, 3 m long <sup>2)</sup>	<b>L49</b>											✓	✓	✓	O. R.	O. R.
Protruding cable ends – right side <sup>3)</sup>	<b>L51</b>											O. R.	O. R.	O. R.	O. R.	O. R.
Protruding cable ends – left side <sup>3)</sup>	<b>L52</b>											O. R.	O. R.	O. R.	O. R.	O. R.
Auxiliary connection box 1XB3 020	<b>L97</b>											✓	✓	✓	✓	✓
Stud terminal for cable connection, accessories pack (3 items)	<b>M46</b>														✓	✓
Saddle terminal for connection without cable lug, accessories pack (6 items)	<b>M47</b>														✓	✓
<b>Windings and insulation</b>																
Temperature class 155 (F), used acc. to 155 (F), with service factor (SF)	<b>C11</b>											✓	✓	✓	✓	✓
Temperature class 155 (F), used acc. to 155 (F), with increased output	<b>C12</b>											✓ <sup>4)</sup>	✓ <sup>4)</sup>	✓ <sup>4)</sup>	✓ <sup>4)</sup>	✓ <sup>4)</sup>
Temperature class 155 (F), used acc. to 155 (F), with increased coolant temperature	<b>C13</b>											✓	✓	✓	✓	✓
Temperature class 180 (H) at rated output and max. CT 60 °C <sup>5)</sup>	<b>C18</b>											✓	✓	✓	✓	✓
Increased air humidity/temperature with 30 to 60 g water per m <sup>3</sup> of air	<b>C19</b>											✓	✓	✓	✓	✓
Temperature class 155 (F), used acc. to 130 (B), coolant temperature 45 °C, derating approx. 4 %	<b>C22</b>											✓ <sup>4)</sup>	✓ <sup>4)</sup>	✓ <sup>4)</sup>	✓ <sup>4)</sup>	✓ <sup>4)</sup>
Temperature class 155 (F), used acc. to 130 (B), coolant temperature 50 °C, derating approx. 8 %	<b>C23</b>											✓ <sup>4)</sup>	✓ <sup>4)</sup>	✓ <sup>4)</sup>	✓ <sup>4)</sup>	✓ <sup>4)</sup>
Temperature class 155 (F), used acc. to 130 (B), coolant temperature 55 °C, derating approx. 13 %	<b>C24</b>											✓ <sup>4)</sup>	✓ <sup>4)</sup>	✓ <sup>4)</sup>	✓ <sup>4)</sup>	✓ <sup>4)</sup>
Temperature class 155 (F), used acc. to 130 (B), coolant temperature 60 °C, derating approx. 18 %	<b>C25</b>											✓ <sup>4)</sup>	✓ <sup>4)</sup>	✓ <sup>4)</sup>	✓ <sup>4)</sup>	✓ <sup>4)</sup>
Increased air humidity/temperature with 60 to 100 g water per m <sup>3</sup> of air	<b>C26</b>											✓	✓	✓	✓	✓
Temperature class 155 (F), used acc. to 130 (B), with increased coolant temperature and/or site altitude	<b>Y50 •</b> and specified output, CT .. °C or SA .... m above sea level											✓	✓	✓	✓	✓
Temperature class 155 (F), used acc. to 155 (F), other requirements	<b>Y52 •</b> and specified output, CT .. °C or SA .... m above sea level											✓	✓	✓	✓	✓

For legend, see Page 2/97, for footnotes, see Page 2/98.

# IEC Squirrel-Cage Motors

## Standard motors up to frame size 315 L

### Special versions

Special versions	Additional identification code <b>-Z</b> with order code and plain text if required	Motor type frame size															
		56	63	71	80	90	100	112	132	160	180	200	225	250	280	315	
<b>Self-ventilated energy-saving motors with improved efficiency – Cast-iron series 1LA6 and 1LG4</b>																	
<b>Colors and paint finish</b>																	
Standard finish in RAL 7030 stone gray												□	□	□	□	□	□
Standard finish in other standard RAL colors: RAL 1002, 1013, 1015, 1019, 2003, 2004, 3000, 3007, 5007, 5009, 5010, 5012, 5015, 5017, 5018, 5019, 6011, 6019, 6021, 7000, 7001, 7004, 7011, 7016, 7022, 7031, 7032, 7033, 7035, 9001, 9002, 9005 Page 0/18	<b>Y53 •</b> and standard finish RAL ....											✓	✓	✓	✓	✓	✓
Special finish in RAL 7030 stone gray <sup>9)</sup>	<b>K26</b>											□	□	□	□	□	□
Special finish in other standard RAL colors: RAL 1002, 1013, 1015, 1019, 2003, 2004, 3000, 3007, 5007, 5009, 5010, 5012, 5015, 5017, 5018, 5019, 6011, 6019, 6021, 7000, 7001, 7004, 7011, 7016, 7022, 7031, 7032, 7033, 7035, 9002, 9005 Page 0/18	<b>Y54 •</b> and special finish RAL ....											✓	✓	✓	✓	✓	✓
Special finish in special RAL colors: For RAL colors, see "Special finish in special RAL colors" on Page 0/19	<b>Y51 •</b> and special finish RAL ....											✓	✓	✓	✓	✓	✓
Offshore special finish	<b>M91</b>											O. R.	O. R.	O. R.	O. R.	O. R.	O. R.
Sea air resistant special finish	<b>M94</b>											O. R.	O. R.	O. R.	O. R.	O. R.	O. R.
Unpainted (only cast iron parts primed)	<b>K23</b>											○	○	○	○	○	○
Unpainted, only primed	<b>K24</b>											✓	✓	✓	✓	✓	✓
<b>Modular technology – Basic versions <sup>7)</sup></b>																	
Mounting of separately driven fan <sup>8)</sup>	<b>G17</b>											✓	✓	✓	✓	✓	✓
Mounting of brake <sup>8) 9)</sup>	<b>G26</b>											–	–	–	–	–	–
Mounting of 1XP8 001-1 (HTL) rotary pulse encoder	<b>H57</b>											✓	✓	✓	✓	✓	✓
Mounting of 1XP8 001-2 (TTL) rotary pulse encoder	<b>H58</b>											✓	✓	✓	✓	✓	✓
<b>Modular technology – Combinations of basic versions <sup>7)</sup></b>																	
Mounting of separately driven fan and 1XP8 001-1 rotary pulse encoder	<b>H61</b>											✓	✓	✓	✓	✓	✓
Mounting of brake and 1XP8 001-1 rotary pulse encoder <sup>9)</sup>	<b>H62</b>											–	–	–	–	–	–
Mounting of brake and separately driven fan <sup>8) 9)</sup>	<b>H63</b>											–	–	–	–	–	–
Mounting of brake, separately driven fan and 1XP8 001-1 rotary pulse encoder <sup>9)</sup>	<b>H64</b>											–	–	–	–	–	–
Mounting of separately driven fan and 1XP8 001-2 rotary pulse encoder	<b>H97</b>											✓	✓	✓	✓	✓	✓
Mounting of brake and 1XP8 001-2 rotary pulse encoder <sup>9)</sup>	<b>H98</b>											–	–	–	–	–	–
Mounting of brake, separately driven fan and 1XP8 001-2 rotary pulse encoder <sup>9)</sup>	<b>H99</b>											–	–	–	–	–	–

For legend, see Page 2/97, for footnotes, see Page 2/98.



# IEC Squirrel-Cage Motors

## Standard motors up to frame size 315 L

### Special versions

Special versions	Additional identification code <b>-Z</b> with order code and plain text if required	Motor type frame size														
		56	63	71	80	90	100	112	132	160	180	200	225	250	280	315
Self-ventilated energy-saving motors with improved efficiency – Cast-iron series 1LA6 and 1LG4																
		1LA6 (cast-iron)					1LG4 (cast-iron)									
<b>Modular technology – Additional versions</b>																
Brake supply voltage 24 V DC	<b>C00</b>						–	–	–	–	✓	✓	✓	✓	✓	✓
Brake supply voltage 400 V AC	<b>C01</b>						–	–	–	–	✓	✓	✓	✓	✓	✓
Mechanical manual brake release with lever (no locking)	<b>K82</b>						–	–	–	–	✓	✓	✓	✓	✓	✓
<b>Special technology <sup>7)</sup></b>																
Mounting of LL 861 900 220 rotary pulse encoder	<b>H70</b>						✓	✓	✓	✓	✓	✓	✓	✓	✓	✓
Mounting of HOG 9 D 1024 I rotary pulse encoder	<b>H72</b>						O. R.	O. R.	O. R.	O. R.	✓	✓	✓	✓	✓	✓
Mounting of HOG 10 D 1024 I rotary pulse encoder	<b>H73</b>						–	–	–	–	✓	✓	✓	✓	✓	✓
Prepared for mounting LL 861 900 220	<b>H78</b>						✓	✓	✓	✓	✓	✓	✓	✓	✓	✓
Prepared for mounting HOG 9 D 1024 I	<b>H79</b>						O. R.	O. R.	O. R.	O. R.	✓	✓	✓	✓	✓	✓
Prepared for mounting HOG 10 D 1024 I	<b>H80</b>						–	–	–	–	✓	✓	✓	✓	✓	✓
Mounting of explosion-proof rotary pulse encoder HOG 10 DN 1024 I, connection box protection against moisture	<b>J15</b>						✓	✓	✓	✓	✓	✓	✓	✓	✓	✓
Mounting of explosion-proof rotary pulse encoder HOG 10 DN 1024 I, connection box protection against dust	<b>J16</b>						✓	✓	✓	✓	✓	✓	✓	✓	✓	✓
Mounting of rotary pulse encoder HOG 10 DN 1024 I + FSL, (speed .... rpm), connection box protection against moisture	<b>Y74 •</b> and specified speed .... rpm						–	–	–	–	✓	✓	✓	✓	✓	✓
Mounting of rotary pulse encoder HOG 10 DN 1024 I + FSL, (speed .... rpm), connection box protection against dust	<b>Y76 •</b> and specified speed .... rpm						–	–	–	–	✓	✓	✓	✓	✓	✓
Mounting of rotary pulse encoder HOG 10 DN 1024 I + ESL 93, (speed .... rpm), connection box protection against dust	<b>Y79 •</b> and specified speed (max. 3) .... rpm						–	–	–	–	✓	✓	✓	✓	✓	✓
<b>Mechanical design and degrees of protection</b>																
Drive-end seal for flange-mounting motors with an oil-tightness of up to 0.1 bar Not possible for IM V3 type of construction <sup>10)</sup>	<b>K17</b>						✓	✓	✓	✓	✓	✓	✓	✓	✓	✓
Low-noise version for 2-pole motors with clockwise direction of rotation <sup>11)</sup>	<b>K37</b>						–	–	✓	✓	✓	✓	✓	✓	✓	✓
Low-noise version for 2-pole motors with counter-clockwise direction of rotation <sup>11)</sup>	<b>K38</b>						–	–	✓	✓	✓	✓	✓	✓	✓	✓
IP65 degree of protection <sup>12)</sup>	<b>K50</b>						✓	✓	✓	✓	✓	✓	✓	✓	✓	✓
IP56 degree of protection (non-heavy-sea) <sup>13)</sup>	<b>K52</b>						✓	✓	✓	✓	✓	✓	✓	✓	✓	✓
Vibration-proof version	<b>L03</b>						✓	✓	✓	✓	–	–	–	–	–	–
Condensation drainage holes <sup>14)</sup>	<b>L12</b>						✓	✓	✓	✓	□	□	□	□	□	□
Non-rusting screws (externally)	<b>M27</b>						✓	✓	✓	✓	✓	✓	✓	✓	✓	✓
Earth brushes for converter-fed operation	<b>M44</b>						–	–	–	–	–	–	–	–	O. R.	O. R.
Mechanical protection for encoder <sup>15)</sup>	<b>M68</b>						✓	✓	✓	✓	✓	✓	✓	✓	✓	✓

2

# IEC Squirrel-Cage Motors

## Standard motors up to frame size 315 L

### Special versions

Special versions	Additional identification code -Z with order code and plain text if required	Motor type frame size														
		56	63	71	80	90	100	112	132	160	180	200	225	250	280	315
<b>Self-ventilated energy-saving motors with improved efficiency – Cast-iron series 1LA6 and 1LG4</b>																
<b>Coolant temperature and site altitude</b>																
Coolant temperature –50 to +40 °C	<b>D02</b>															
Coolant temperature –40 to +40 °C	<b>D03</b>															
Coolant temperature –30 to +40 °C	<b>D04</b>															
<b>Designs in accordance with standards and specifications</b>																
Electrical according to NEMA MG1-12	<b>D30</b>															
Design according to UL with "Recognition Mark" <sup>16)</sup>	<b>D31</b>															
Canadian regulations (CSA) <sup>17)</sup>	<b>D40</b>															
PSE Mark Japan <sup>18)</sup>	<b>D46</b>															
VIK version (includes Zone 2 for mains-fed operation, without Ex nA II on rating plate)	<b>K30</b>															
<b>Bearings and lubrication</b>																
Measuring nipple for SPM shock pulse measurement for bearing inspection	<b>G50</b>															
Bearing design for increased cantilever forces <sup>19)</sup>	<b>K20</b>															
Special bearing for DE and NDE, bearing size	<b>K36</b>															
Regreasing device	<b>K40</b>															
Located bearing DE	<b>K94</b>															
Located bearing NDE	<b>L04</b>															
Insulated bearing cartridge	<b>L27</b>															
<b>Balance and vibration quantity</b>																
Vibration quantity A																
Vibration quantity B	<b>K02</b>															
Full key balancing	<b>L68</b>															
Balancing without key	<b>M37</b>															
<b>Shaft and rotor</b>																
Concentricity of shaft extension, coaxiality and linear movement in accordance with DIN 42955 Tolerance R for flange-mounting motors <sup>21)</sup>	<b>K04</b>															
Second standard shaft extension <sup>22)</sup>	<b>K16</b>															
Shaft extension with normal dimensions without featherkey way	<b>K42</b>															
Concentricity of shaft extension in accordance with DIN 42955 Tolerance R	<b>L39</b>															
Standard shaft made of non-rusting steel	<b>M65</b>															
Non-standard cylindrical shaft extension <sup>23)</sup>	<b>Y55 • and identification code</b>															
<b>Heating and ventilation</b>																
Fan cover for textile industry	<b>H17</b>															
Metal external fan <sup>24)</sup>	<b>K35</b>															
Anti-condensation heaters for 230 V	<b>K45</b>															
Anti-condensation heaters for 115 V	<b>K46</b>															
Sheet metal fan cover	<b>L36</b>															
Separately driven fan with non-standard voltage and/or frequency	<b>Y81 • and identification code</b>															

For legend, see Page 2/97, for footnotes, see Page 2/98.

# IEC Squirrel-Cage Motors

## Standard motors up to frame size 315 L

### Special versions

Special versions	Additional identification code <b>-Z</b> with order code and plain text if required	Motor type frame size														
		56	63	71	80	90	100	112	132	160	180	200	225	250	280	315
<b>Self-ventilated energy-saving motors with improved efficiency – Cast-iron series 1LA6 and 1LG4</b>																
<b>Rating plate and extra rating plates</b>																
Second lubricating plate, supplied loose	<b>B06</b>															
Second rating plate, loose	<b>K31</b>															
Extra rating plate or rating plate with deviating rating plate data	<b>Y80 •</b> and identification code															
Extra rating plate with identification codes	<b>Y82 •</b> and identification code															
Additional information on rating plate and on package label (maximum of 20 characters)	<b>Y84 •</b> and identification code															
<b>Packaging, safety notes, documentation and test certificates</b>																
Without safety and commissioning note. Customer's declaration of renouncement required.	<b>B00</b>															
With one safety and startup guide per box pallet	<b>B01</b>															
Acceptance test certificate 3.1 according to EN 10204	<b>B02</b>															
Operating instructions German/English in print	<b>B23</b>															
Type test with heat run for vertical motors, with acceptance	<b>F83</b>															
Wire-lattice pallet	<b>L99</b>															
Connected in star for dispatch	<b>M32</b>															
Connected in delta for dispatch	<b>M33</b>															

- Standard version
- Without additional charge
- This order code only determines the price of the version – Additional plain text is required.
- . R. Possible on request
- ✓ With additional charge
- Not possible

# IEC Squirrel-Cage Motors

## Standard motors up to frame size 315 L

### Special versions

2

- 1) Evaluation with appropriate tripping unit (see Catalog LV 1) is recommended.
- 2) In combination with the PTC thermistor option or anti-condensation heating option, please inquire before ordering.
- 3) Possible in combination with order code **L44** to **L49** or length specification in plain text.
- 4) Only the 50 Hz data are indicated on the rating plate.
- 5) Cannot be used for motors in UL version (order code **D31**). Cannot be used for motors according to CSA approval (order code **D40**) for motor serie 1LG4. The grease lifetime specified in catalog part 0 "Introduction" refers to CT 40 °C. When the coolant temperature rises by 10 K, the grease lifetime or relubrication interval is halved.
- 6) For frame sizes 100 to 160, do not specify an order code. Order code is only necessary for frame sizes 180 to 315.
- 7) A second shaft extension is not possible. Please inquire for mounted brakes. The order codes listed cannot be combined within the various technologies nor with each other within the same technology system. This applies for:
  - Modular technology
  - Basic versions of "Modular technology"
  - Combination of special versions "Special technology"
- 8) For 1LG4/1LG6 motors, order codes **G17**, **G26** and **H63** frame size 225 and above can also be combined with all rotary pulse encoders in the "Special technology" range.
- 9) The standard brake supply voltage is 230 V AC, 50/60 Hz. Other brake supply voltages are possible with order codes **C00** and **C01**.
- 10) Not possible for motor series 1LG4 for 2-pole motors.
- 11) For 1LG4 motors in low-noise version a second shaft extension and/or mounting of an encoder are not possible.)
- 12) Not possible in combination with rotary pulse encoder HOG 9 D 10241 (order code **H72**, **H79**) and/or brake 2LM8 (used for motors up to and including frame size 225, order code **G26**).
- 13) Not possible in combination with brake 2LM8 (used for motors up to and including frame size 225, order code **G26**).
- 14) Supplied with the condensation drainage holes sealed at the drive end DE and non-drive end NDE (IP55, IP56, IP65). If condensation drainage holes are required in motors of the IM B6, IM B7 or IM B8 type of construction (feet located on side or top), it is necessary to relocate the bearing plates at the drive end (DE) and non-drive end (NDE) so that the condensation drainage holes situated between the feet on delivery are underneath.
- 15) Not necessary when a rotary pulse encoder is combined with a separately driven fan, because in this case the rotary pulse encoder is installed under the fan cowl.
- 16) Possible up to 600 V max. Order with voltage code **9** and order code for voltage and frequency. The rated voltage is indicated on the rating plate.
- 17) Order with voltage code **9** and order code for voltage and frequency. The rated voltage is indicated on the rating plate.
- 18) "Small power motors" with a rated output of up to 3 kW which are exported to Japan must bear the PSE marking.
- 19) Not possible for 2-pole 1LG4 motors, frame size 315 L in vertical types of construction; bearings for increased cantilever forces at vibration quantity level A available on request for 1LG4 motors. Not possible for 1LG4 motors in the combination "Concentricity of the shaft extension, coaxiality and linear movement in accordance with DIN 42955 Tolerance R for flange-mounting motors" – order code **K04**.
- 20) Additional charge for 2-pole motors. With 4-pole to 8-pole motors, standard version.
- 21) Can be combined with deep-groove bearings of series 60..., 62... and 63... Not possible in combination with parallel roller bearings (e.g. bearings for increased cantilever forces, order code **K20**), brake mounting or encoder mounting.
- 22) Possible for motors of frame size 315 and above in vertical types of construction or 2-pole for version with second shaft extension on request. Version with protective cover not possible.
- 23) When motors are ordered that have a longer or shorter shaft extension than normal, the required position and length of the featherkey way must be specified in a sketch. It must be ensured that only featherkeys in accordance with DIN 6885, Form A are permitted to be used. The featherkey way is positioned centrally on the shaft extension. The length is defined by the manufacturer normatively. Not valid for: Conical shafts, non-standard threaded journals, non-standard shaft tolerances, friction welded journals, extremely "thin" shafts, special geometry dimensions (e.g. square journals), hollow shafts. Valid for non-standard shaft extensions DE or NDE. The featherkeys are supplied in every case. For order codes **Y55** and **K16**:
  - Dimensions D and DA  $\leq$  internal diameter of roller bearing (see dimension tables under "Dimensions")
  - Dimensions E and EA  $\leq$  2 x length E (normal) of the shaft extension
 For an explanation of the order codes, see catalog part 0 "Introduction".
- 24) For 1LA5/6/7/9 motors and 1LG with metal external fan, converter-fed operation is permitted. The metal external fan is not possible in combination with the low-noise version – order code **K37** or **K38**.

# IEC Squirrel-Cage Motors

## Standard motors up to frame size 315 L

**Special versions**
Options or order codes (supplement **-Z** is required)

Special versions	Additional identification code <b>-Z</b> with order code and plain text if required	Motor type frame size													
		56	63	71	80	90	100	112	132	160	180	200	225	250	280
<b>Self-ventilated motors with increased output – Cast-iron series 1LG4</b>															
<b>1LG4 (cast-iron)</b>															
<b>Motor protection</b>															
Motor protection with PTC thermistors with 3 embedded temperature sensors for tripping <sup>1)</sup>	<b>A11</b>										✓	✓	✓	✓	✓
Motor protection with PTC thermistors with 6 embedded temperature sensors for tripping and alarm <sup>1)</sup>	<b>A12</b>										✓	✓	✓	✓	✓
Motor temperature detection with embedded temperature sensor KTY 84-130 <sup>1)</sup>	<b>A23</b>										✓	✓	✓	✓	✓
Motor temperature detection with embedded temperature sensors 2 x KTY 84-130 <sup>1)</sup>	<b>A25</b>										✓	✓	✓	✓	✓
Temperature detectors for tripping <sup>1)</sup>	<b>A31</b>										✓	✓	✓	✓	✓
Installation of 3 PT 100 resistance thermometers <sup>1)</sup>	<b>A60</b>										✓	✓	✓	✓	✓
Installation of 6 PT 100 resistance thermometers in stator winding <sup>1)</sup>	<b>A61</b>										✓	✓	✓	✓	✓
Installation of 2 PT 100 screw-in resistance thermometers (basic circuit) for rolling-contact bearings <sup>1)</sup>	<b>A72</b>										✓	✓	✓	✓	✓
Installation of 2 PT 100 screw-in resistance thermometers (3-wire circuit) for rolling-contact bearings <sup>1)</sup>	<b>A78</b>										✓	✓	✓	✓	✓
Installation of 2 PT 100 double screw-in resistance thermometers (3-wire circuit) for rolling-contact bearings <sup>1)</sup>	<b>A80</b>										✓	✓	✓	✓	✓
<b>Motor connection and connection box</b>															
Two-part plate on connection box	<b>K06</b>										–	✓	✓	✓	✓
Connection box on RHS	<b>K09</b>										✓	✓	✓	✓	✓
Connection box on LHS	<b>K10</b>										✓	✓	✓	✓	✓
Connection box on top, feet screwed on	<b>K11</b>										✓	✓	✓	✓	✓
Connection box in cast-iron version	<b>K15</b>										✓	✓	✓	□	□
One cable gland, metal	<b>K54</b>										✓	✓	✓	✓	✓
Cable gland, maximum configuration	<b>K55</b>										✓	✓	✓	✓	✓
Rotation of the connection box through 90°, entry from DE	<b>K83</b>										✓	✓	✓	✓	✓
Rotation of the connection box through 90°, entry from NDE	<b>K84</b>										✓	✓	✓	✓	✓
Rotation of connection box through 180°	<b>K85</b>										✓	✓	✓	✓	✓
Next larger connection box	<b>L00</b>										✓	✓	✓	✓	✓
Undrilled entry plate	<b>L01</b>										○	○	○	○	○
External earthing	<b>L13</b>										□	□	□	□	□
6 cables protruding, 1.5 m long <sup>2)</sup>	<b>L48</b>										✓	✓	✓	O. R.	O. R.
6 cables protruding, 3 m long <sup>2)</sup>	<b>L49</b>										✓	✓	✓	O. R.	O. R.
Protruding cable ends – right side <sup>3)</sup>	<b>L51</b>										O. R.	O. R.	O. R.	O. R.	O. R.
Protruding cable ends – left side <sup>3)</sup>	<b>L52</b>										O. R.	O. R.	O. R.	O. R.	O. R.
Auxiliary connection box 1XB3 020	<b>L97</b>										✓	✓	✓	✓	✓

For legend, see Page 2/103, for footnotes, see Page 2/104.

# IEC Squirrel-Cage Motors

## Standard motors up to frame size 315 L

### Special versions

Special versions	Additional identification code -Z with order code and plain text if required	Motor type frame size													
		56	63	71	80	90	100	112	132	160	180	200	225	250	280
<b>Self-ventilated motors with increased output – Cast-iron series 1LG4</b>															
<b>1LG4 (cast-iron)</b>															
<b>Motor connection and connection box (continued)</b>															
Stud terminal for cable connection, accessories pack (3 items)	<b>M46</b>													✓	✓
Saddle terminal for connection without cable lug, accessories pack (6 items)	<b>M47</b>													✓	✓
<b>Windings and insulation</b>															
Temperature class 155 (F), used acc. to 155 (F), with service factor (SF)	<b>C11</b>										✓	✓	✓	✓	✓
Temperature class 155 (F), used acc. to 155 (F), with increased output <sup>5)</sup>	<b>C12</b>										✓	✓	✓	✓	✓
Temperature class 155 (F), used acc. to 155 (F), with increased coolant temperature	<b>C13</b>										✓	✓	✓	✓	✓
Increased air humidity/temperature with 30 to 60 g water per m <sup>3</sup> of air	<b>C19</b>										✓	✓	✓	✓	✓
Temperature class 155 (F), used acc. to 130 (B), coolant temperature 45 °C, derating approx. 4 % <sup>4)</sup>	<b>C22</b>										✓	✓	✓	✓	✓
Temperature class 155 (F), used acc. to 130 (B), coolant temperature 50 °C, derating approx. 8 % <sup>4)</sup>	<b>C23</b>										✓	✓	✓	✓	✓
Temperature class 155 (F), used acc. to 130 (B), coolant temperature 55 °C, derating approx. 13 % <sup>4)</sup>	<b>C24</b>										✓	✓	✓	✓	✓
Temperature class 155 (F), used acc. to 130 (B), coolant temperature 60 °C, derating approx. 18 % <sup>4)</sup>	<b>C25</b>										✓	✓	✓	✓	✓
Increased air humidity/temperature with 60 to 100 g water per m <sup>3</sup> of air	<b>C26</b>										✓	✓	✓	✓	✓
Temperature class 155 (F), used acc. to 130 (B), with increased coolant temperature and/or site altitude	<b>Y50 •</b> and specified output, CT... °C or SA .... m above sea level										✓	✓	✓	✓	✓
<b>Colors and paint finish</b>															
Standard finish in RAL 7030 stone gray											□	□	□	□	□
Standard finish in other standard RAL colors: RAL 1002, 1013, 1015, 1019, 2003, 2004, 3000, 3007, 5007, 5009, 5010, 5012, 5015, 5017, 5018, 5019, 6011, 6019, 6021, 7000, 7001, 7004, 7011, 7016, 7022, 7031, 7032, 7033, 7035, 9001, 9002, 9005 Page 0/18	<b>Y53 •</b> and standard finish RAL ....										✓	✓	✓	✓	✓
Special finish in RAL 7030 stone gray	<b>K26</b>										✓	✓	✓	✓	✓
Special finish in other standard RAL colors: RAL 1002, 1013, 1015, 1019, 2003, 2004, 3000, 3007, 5007, 5009, 5010, 5012, 5015, 5017, 5018, 5019, 6011, 6019, 6021, 7000, 7001, 7004, 7011, 7016, 7022, 7031, 7032, 7033, 7035, 9001, 9002, 9005 Page 0/18	<b>Y54 •</b> and special finish RAL ....										✓	✓	✓	✓	✓

For legend, see Page 2/103, for footnotes, see Page 2/104.

# IEC Squirrel-Cage Motors

## Standard motors up to frame size 315 L

### Special versions

Special versions	Additional identification code -Z with order code and plain text if required	Motor type frame size													
		56	63	71	80	90	100	112	132	160	180	200	225	250	280
<b>Self-ventilated motors with increased output – Cast-iron series 1LG4</b>															
<b>1LG4 (cast-iron)</b>															
<b>Colors and paint finish (continued)</b>															
Special finish in special RAL colors: For RAL colors, see "Special finish in special RAL colors" on Page 0/19	<b>Y51 •</b> and special finish RAL ....										✓	✓	✓	✓	✓
Offshore special finish	<b>M91</b>										✓	✓	✓	✓	✓
Sea air resistant special finish	<b>M94</b>										O. R.	O. R.	O. R.	O. R.	O. R.
Unpainted (only cast iron parts primed)	<b>K23</b>										○	○	○	○	○
Unpainted, only primed	<b>K24</b>										✓	✓	✓	✓	✓
<b>Modular technology – Basic versions <sup>5)</sup></b>															
Mounting of separately driven fan <sup>6)</sup>	<b>G17</b>										✓	✓	✓	✓	✓
Mounting of brake <sup>6) 7)</sup>	<b>G26</b>										✓	✓	✓	✓	✓
Mounting of 1XP8 001-1 (HTL) rotary pulse encoder	<b>H57</b>										✓	✓	✓	✓	✓
Mounting of 1XP8 001-2 (TTL) rotary pulse encoder	<b>H58</b>										✓	✓	✓	✓	✓
<b>Modular technology – Combinations of basic versions <sup>6)</sup></b>															
Mounting of separately driven fan and 1XP8 001-1 rotary pulse encoder	<b>H61</b>										✓	✓	✓	✓	✓
Mounting of brake and 1XP8 001-1 rotary pulse encoder <sup>7)</sup>	<b>H62</b>										✓	✓	✓	✓	✓
Mounting of brake and separately driven fan <sup>6) 7)</sup>	<b>H63</b>										✓	✓	✓	✓	✓
Mounting of brake, separately driven fan and 1XP8 001-1 rotary pulse encoder <sup>7)</sup>	<b>H64</b>										✓	✓	✓	✓	✓
Mounting of separately driven fan and 1XP8 001-2 rotary pulse encoder	<b>H97</b>										✓	✓	✓	✓	✓
Mounting of brake and 1XP8 001-2 rotary pulse encoder <sup>7)</sup>	<b>H98</b>										✓	✓	✓	✓	✓
Mounting of brake, separately driven fan and 1XP8 001-2 rotary pulse encoder <sup>7)</sup>	<b>H99</b>										✓	✓	✓	✓	✓
<b>Modular technology – Additional versions</b>															
Brake supply voltage 24 V DC	<b>C00</b>										✓	✓	✓	✓	✓
Brake supply voltage 400 V AC	<b>C01</b>										✓	✓	✓	✓	✓
Mechanical manual brake release with lever (no locking)	<b>K82</b>										✓	✓	✓	✓	✓
<b>Special technology <sup>5)</sup></b>															
Mounting of LL 861 900 220 rotary pulse encoder	<b>H70</b>										✓	✓	✓	✓	✓
Mounting of HOG 9 D 1024 I rotary pulse encoder	<b>H72</b>										✓	✓	✓	✓	✓
Mounting of HOG 10 D 1024 I rotary pulse encoder	<b>H73</b>										✓	✓	✓	✓	✓
Prepared for mounting LL 861 900 220	<b>H78</b>										✓	✓	✓	✓	✓
Prepared for mounting HOG 9 D 1024 I	<b>H79</b>										✓	✓	✓	✓	✓
Prepared for mounting HOG 10 D 1024 I	<b>H80</b>										✓	✓	✓	✓	✓
Mounting of explosion-proof rotary pulse encoder HOG 10 DN 1024 I, connection box protection against moisture	<b>J15</b>										✓	✓	✓	✓	✓
Mounting of explosion-proof rotary pulse encoder HOG 10 DN 1024 I, connection box protection against dust	<b>J16</b>										✓	✓	✓	✓	✓

For legend, see Page 2/103, for footnotes, see Page 2/104.

# IEC Squirrel-Cage Motors

## Standard motors up to frame size 315 L

### Special versions

Special versions	Additional identification code -Z with order code and plain text if required	Motor type frame size														
		56	63	71	80	90	100	112	132	160	180	200	225	250	280	315
<b>Self-ventilated motors with increased output – Cast-iron series 1LG4</b>																
<b>Special technology <sup>5)</sup> (continued)</b>																
Mounting of rotary pulse encoder HOG 10 DN 1024 I + FSL, (speed .... rpm), connection box protection against moisture	<b>Y74 •</b> and specified speed .... rpm											✓	✓	✓	✓	✓
Mounting of rotary pulse encoder HOG 10 DN 1024 I + FSL, (speed .... rpm), connection box protection against dust	<b>Y76 •</b> and specified speed .... rpm											✓	✓	✓	✓	✓
Mounting of rotary pulse encoder HOG 10 DN 1024 I + ESL 93, (speed .... rpm), connection box protection against dust	<b>Y79 •</b> and specified speed (max. 3) .... rpm											✓	✓	✓	✓	✓
<b>Mechanical design and degrees of protection</b>																
Drive-end seal for flange-mounting motors with an oil-tightness of up to 0.1 bar Not possible for IM V3 type of construction <sup>8)</sup>	<b>K17</b>											✓	✓	✓	✓	✓
Low-noise version for 2-pole motors with clockwise direction of rotation <sup>9)</sup>	<b>K37</b>											✓	✓	✓	✓	✓
Low-noise version for 2-pole motors with counter-clockwise direction of rotation <sup>9)</sup>	<b>K38</b>											✓	✓	✓	✓	✓
IP65 degree of protection <sup>10)</sup>	<b>K50</b>											✓	✓	✓	✓	✓
IP56 degree of protection (non-heavy-sea) <sup>11)</sup>	<b>K52</b>											✓	✓	✓	✓	✓
Condensation drainage holes <sup>12)</sup>	<b>L12</b>											□	□	□	□	□
Non-rusting screws (externally)	<b>M27</b>											✓	✓	✓	✓	✓
Earth brushes for converter-fed operation	<b>M44</b>											–	–	–	–	O. R.
Mechanical protection for encoder <sup>13)</sup>	<b>M68</b>											✓	✓	✓	✓	✓
<b>Coolant temperature and site altitude</b>																
Coolant temperature –50 to +40 °C	<b>D02</b>											✓	✓	✓	✓	✓
Coolant temperature –40 to +40 °C	<b>D03</b>											✓	✓	✓	✓	✓
Coolant temperature –30 to +40 °C	<b>D04</b>											✓	✓	✓	✓	✓
<b>Designs in accordance with standards and specifications</b>																
Electrical according to NEMA MG1-12	<b>D30</b>											✓	✓	✓	✓	✓
Design according to UL with "Recognition Mark" <sup>14)</sup>	<b>D31</b>											✓	✓	✓	✓	✓
Canadian regulations (CSA) <sup>15)</sup>	<b>D40</b>											✓	✓	✓	✓	✓
<b>Bearings and lubrication</b>																
Measuring nipple for SPM shock pulse measurement for bearing inspection	<b>G50</b>											✓	✓	✓	✓	✓
Bearing design for increased cantilever forces <sup>16)</sup>	<b>K20</b>											✓	✓	✓	✓	✓
Special bearing for DE and NDE, bearing size	<b>K36</b>											✓	✓	✓	✓	✓ <sup>17)</sup>
Regreasing device	<b>K40</b>											✓	✓	✓	✓	□
Located bearing DE	<b>K94</b>											✓	✓	✓	✓	✓
Located bearing NDE	<b>L04</b>											□	□	□	□	□
Insulated bearing cartridge	<b>L27</b>											–	–	✓	✓	✓
<b>Balance and vibration quantity</b>																
Vibration quantity A												□	□	□	□	□
Vibration quantity B	<b>K02</b>											✓	✓	✓	✓	✓
Full key balancing	<b>L68</b>											✓	✓	✓	✓	✓
Balancing without key	<b>M37</b>											✓	✓	✓	✓	✓

For legend, see Page 2/103, for footnotes, see Page 2/104.



# IEC Squirrel-Cage Motors

## Standard motors up to frame size 315 L

### Special versions

Special versions	Additional identification code -Z with order code and plain text if required	Motor type frame size													
		56	63	71	80	90	100	112	132	160	180	200	225	250	280
<b>Self-ventilated motors with increased output – Cast-iron series 1LG4</b>															
<b>1LG4 (cast-iron)</b>															
<b>Shaft and rotor</b>															
Concentricity of shaft extension, coaxiality and linear movement in accordance with DIN 42955 Tolerance R for flange-mounting motors <sup>18)</sup>	<b>K04</b>										✓	✓	✓	✓	✓
Second standard shaft extension <sup>19)</sup>	<b>K16</b>										✓	✓	✓	✓	✓
Shaft extension with normal dimensions without featherkey way	<b>K42</b>										✓	✓	✓	✓	✓
Concentricity of shaft extension in accordance with DIN 42955 Tolerance R	<b>L39</b>										✓	✓	✓	✓	✓
Non-standard cylindrical shaft extension <sup>20)</sup>	<b>Y55 •</b> and identification code										✓	✓	✓	✓	✓
<b>Heating and ventilation</b>															
Metal external fan <sup>21)</sup>	<b>K35</b>										✓	✓	✓	✓	✓
Anti-condensation heaters for 230 V	<b>K45</b>										✓	✓	✓	✓	✓
Anti-condensation heaters for 115 V	<b>K46</b>										✓	✓	✓	✓	✓
Sheet metal fan cover	<b>L36</b>										✓	✓	✓	✓	✓
Separately driven fan with non-standard voltage and/or frequency	<b>Y81 •</b> and identification code										–	–	✓	✓	✓
<b>Rating plate and extra rating plates</b>															
Second lubricating plate, supplied loose	<b>B06</b>										✓	✓	✓	✓	✓
Second rating plate, loose	<b>K31</b>										✓	✓	✓	✓	✓
Extra rating plate or rating plate with deviating rating plate data	<b>Y80 •</b> and identification code										✓	✓	✓	✓	✓
Extra rating plate with identification codes	<b>Y82 •</b> and identification code										✓	✓	✓	✓	✓
Additional information on rating plate and on package label (maximum of 20 characters)	<b>Y84 •</b> and identification code										✓	✓	✓	✓	✓
<b>Packaging, safety notes, documentation and test certificates</b>															
Acceptance test certificate 3.1 according to EN 10204	<b>B02</b>										✓	✓	✓	✓	✓
Operating instructions German/English enclosed in print	<b>B23</b>										✓	✓	✓	✓	✓
Type test with heat run for horizontal motors, with acceptance	<b>F83</b>										✓	✓	✓	✓	✓
Connected in star for dispatch	<b>M32</b>										✓	✓	✓	✓	✓
Connected in delta for dispatch	<b>M33</b>										✓	✓	□	□	□

- Standard version
- Without additional charge
- This order code only determines the price of the version – Additional plain text is required.
- R. Possible on request
- ✓ With additional charge
- Not possible

# IEC Squirrel-Cage Motors

## Standard motors up to frame size 315 L

### Special versions

2

- 1) Evaluation with appropriate tripping unit (see Catalog LV 1) is recommended.
- 2) In combination with the PTC thermistor option or anti-condensation heating option, please inquire before ordering.
- 3) Possible in combination with order code **L44** to **L49** or length specification in plain text.
- 4) Only the 50 Hz data are indicated on the rating plate.
- 5) A second shaft extension is not possible. Please inquire for mounted brakes. The order codes listed cannot be combined within the various technologies nor with each other within the same technology system. This applies for:
  - Modular technology
  - Basic versions of "Modular technology"
  - Combination of special versions "Special technology"
- 6) For 1LG4/1LG6 motors, order codes **G17**, **G26** and **H63** frame size 225 and above can also be combined with all rotary pulse encoders in the "Special technology" range.
- 7) The standard brake supply voltage is 230 V AC, 50/60 Hz. Other brake supply voltages are possible with order codes **C00** and **C01**.
- 8) Not possible for motor series 1LG4 for 2-pole motors.
- 9) For 1LG4 motors in low-noise version a second shaft extension and/or mounting of an encoder are not possible.)
- 10) Not possible in combination with rotary pulse encoder HOG 9 D 10241 (order code **H72**, **H79**) and/or brake 2LM8 (used for motors up to and including frame size 225, order code **G26**).
- 11) Not possible in combination with brake 2LM8 (used for motors up to and including frame size 225, order code **G26**).
- 12) Supplied with the condensation drainage holes sealed at the drive end DE and non-drive end NDE (IP55, IP56, IP65). If condensation drainage holes are required in motors of the IM B6, IM B7 or IM B8 type of construction (feet located on side or top), it is necessary to relocate the bearing plates at the drive end (DE) and non-drive end (NDE) so that the condensation drainage holes situated between the feet on delivery are underneath.
- 13) Not necessary when a rotary pulse encoder is combined with a separately driven fan, because in this case the rotary pulse encoder is installed under the fan cowl.
- 14) Possible up to 600 V max. Order with voltage code **9** and order code for voltage and frequency. The rated voltage is indicated on the rating plate.
- 15) Order with voltage code **9** and order code for voltage and frequency. The rated voltage is indicated on the rating plate.
- 16) Not possible for 2-pole 1LG4 motors, frame size 315 L in vertical types of construction; bearings for increased cantilever forces at vibration quantity level A available on request for 1LG4 motors. Not possible for 1LG4 motors in the combination "Concentricity of the shaft extension, coaxiality and linear movement in accordance with DIN 42955 Tolerance R for flange-mounting motors" – order code **K04**.
- 17) Extra charge for 2-pole motors. With 4-pole to 8-pole motors, standard version.
- 18) Can be combined with deep-groove bearings of series 60.., 62.. and 63... Not possible in combination with parallel roller bearings (e.g. bearings for increased cantilever forces, order code **K20**), brake mounting or encoder mounting.
- 19) Possible for motors of frame size 315 and above in vertical types of construction or 2-pole for version with second shaft extension on request. Version with protective cover not possible.
- 20) When motors are ordered that have a longer or shorter shaft extension than normal, the required position and length of the featherkey way must be specified in a sketch. It must be ensured that only featherkeys in accordance with DIN 6885, Form A are permitted to be used. The featherkey way is positioned centrally on the shaft extension. The length is defined by the manufacturer normatively. Not valid for: Conical shafts, non-standard threaded journals, non-standard shaft tolerances, friction welded journals, extremely "thin" shafts, special geometry dimensions (e.g. square journals), hollow shafts. Valid for non-standard shaft extensions DE or NDE. The featherkeys are supplied in every case. For order codes **Y55** and **K16**:
  - Dimensions D and DA  $\leq$  internal diameter of roller bearing (see dimension tables under "Dimensions")
  - Dimensions E and EA  $\leq$  x length E (normal) of the shaft extension
 For an explanation of the order codes, see catalog part 0 "Introduction".
- 21) For 1LA5/6/7/9 motors and 1LG with metal external fan, converter-fed operation is permitted. The metal external fan is not possible in combination with the low-noise version – order code **K37** or **K38**.

# IEC Squirrel-Cage Motors

## Standard motors up to frame size 315 L

**Special versions**
Options or order codes (supplement **-Z** is required)

Special versions	Additional identification code <b>-Z</b> with order code and plain text if required	Motor type frame size														
		56	63	71	80	90	100	112	132	160	180	200	225	250	280	315
<b>Self-ventilated energy-saving motors with high efficiency – Cast-iron series 1LG6</b>																
<b>1LG6 (cast-iron)</b>																
<b>Motor protection</b>																
Motor protection with PTC thermistors with 3 embedded temperature sensors for tripping <sup>1)</sup>	<b>A11</b>										✓	✓	✓	✓	✓	✓
Motor protection with PTC thermistors with 6 embedded temperature sensors for tripping and alarm <sup>1)</sup>	<b>A12</b>										✓	✓	✓	✓	✓	✓
Motor temperature detection with embedded temperature sensor KTY 84-130 <sup>1)</sup>	<b>A23</b>										✓	✓	✓	✓	✓	✓
Motor temperature detection with embedded temperature sensors 2 x KTY 84-130 <sup>1)</sup>	<b>A25</b>										✓	✓	✓	✓	✓	✓
Temperature detectors for tripping <sup>1)</sup>	<b>A31</b>										✓	✓	✓	✓	✓	✓
Installation of 3 PT 100 resistance thermometers <sup>1)</sup>	<b>A60</b>										✓	✓	✓	✓	✓	✓
Installation of 6 PT 100 resistance thermometers in stator winding <sup>1)</sup>	<b>A61</b>										✓	✓	✓	✓	✓	✓
Installation of 2 PT 100 screw-in resistance thermometers (basic circuit) for rolling-contact bearings <sup>1)</sup>	<b>A72</b>										✓	✓	✓	✓	✓	✓
Installation of 2 PT100 screw-in resistance thermometers (3-wire circuit) for rolling-contact bearings <sup>1)</sup>	<b>A78</b>										✓	✓	✓	✓	✓	✓
Installation of 2 PT 100 double screw-in resistance thermometers (3-wire circuit) for rolling-contact bearings <sup>1)</sup>	<b>A80</b>										✓	✓	✓	✓	✓	✓
<b>Motor connection and connection box</b>																
Two-part plate on connection box	<b>K06</b>										–	✓	✓	✓	✓	✓
Connection box on RHS	<b>K09</b>										✓	✓	✓	✓	✓	✓
Connection box on LHS	<b>K10</b>										✓	✓	✓	✓	✓	✓
Connection box on top, feet screwed on	<b>K11</b>										✓	✓	✓	✓	✓	✓
Connection box in cast-iron version	<b>K15</b>										✓	✓	✓	□	□	□
One cable gland, metal	<b>K54</b>										✓	✓	✓	✓	✓	✓
Cable gland, maximum configuration	<b>K55</b>										✓	✓	✓	✓	✓	✓
Rotation of the connection box through 90°, entry from DE	<b>K83</b>										✓	✓	✓	✓	✓	✓
Rotation of the connection box through 90°, entry from NDE	<b>K84</b>										✓	✓	✓	✓	✓	✓
Rotation of connection box through 180°	<b>K85</b>										✓	✓	✓	✓	✓	✓
Next larger connection box	<b>L00</b>										✓	✓	✓	✓	✓	✓
Undrilled entry plate	<b>L01</b>										○	○	○	○	○	○
External earthing	<b>L13</b>										□	□	□	□	□	□

2

# IEC Squirrel-Cage Motors

## Standard motors up to frame size 315 L

### Special versions

Special versions	Additional identification code <b>-Z</b> with order code and plain text if required	Motor type frame size															
		56	63	71	80	90	100	112	132	160	180	200	225	250	280	315	
<b>Self-ventilated energy-saving motors with high efficiency – Cast-iron series 1LG6</b>																	
												<b>1LG6 (cast-iron)</b>					
<b>Motor connection and connection box (continued)</b>																	
6 cables protruding, 1.5 m long <sup>2)</sup>	<b>L48</b>											✓	✓	✓	O. R.	O. R.	O. R.
6 cables protruding, 3 m long <sup>2)</sup>	<b>L49</b>											✓	✓	✓	O. R.	O. R.	O. R.
Protruding cable ends – right side <sup>3)</sup>	<b>L51</b>											O. R.	O. R.	O. R.	O. R.	O. R.	O. R.
Protruding cable ends – left side <sup>3)</sup>	<b>L52</b>											O. R.	O. R.	O. R.	O. R.	O. R.	O. R.
Auxiliary connection box 1XB3 020	<b>L97</b>											✓	✓	✓	✓	✓	✓
Stud terminal for cable connection, accessories pack (3 items)	<b>M46</b>											–	–	–	✓	✓	✓
Saddle terminal for connection without cable lug, accessories pack (6 items)	<b>M47</b>											–	–	–	✓	✓	✓
<b>Windings and insulation</b>																	
Temperature class 155 (F), used acc. to 155 (F), with service factor (SF)	<b>C11</b>											✓	✓	✓	✓	✓	✓
Temperature class 155 (F), used acc. to 155 (F), with increased output <sup>4)</sup>	<b>C12</b>											✓	✓	✓	✓	✓	✓
Temperature class 155 (F), used acc. to 155 (F), with increased coolant temperature	<b>C13</b>											✓	✓	✓	✓	✓	✓
Increased air humidity/temperature, with 30 to 60 g water per m <sup>3</sup> of air	<b>C19</b>											✓	✓	✓	✓	✓	✓
Temperature class 155 (F), used acc. to 130 (B), coolant temperature 45 °C, derating approx. 4 % <sup>4)</sup>	<b>C22</b>											✓	✓	✓	✓	✓	✓
Temperature class 155 (F), used acc. to 130 (B), coolant temperature 50 °C, derating approx. 8 % <sup>4)</sup>	<b>C23</b>											✓	✓	✓	✓	✓	✓
Temperature class 155 (F), used acc. to 130 (B), coolant temperature 55 °C, derating approx. 13 % <sup>4)</sup>	<b>C24</b>											✓	✓	✓	✓	✓	✓
Temperature class 155 (F), used acc. to 130 (B), coolant temperature 60 °C, derating approx. 18 % <sup>4)</sup>	<b>C25</b>											✓	✓	✓	✓	✓	✓
Increased air humidity/temperature with 60 to 100 g water per m <sup>3</sup> of air	<b>C26</b>											✓	✓	✓	✓	✓	✓
Temperature class 155 (F), used acc. to 130 (B), with increased coolant temperature and/or site altitude	<b>Y50</b> • and specified output, CT .. °C or SA .... m above sea level											✓	✓	✓	✓	✓	✓
Temperature class 155 (F), used acc. to 155 (F), other requirements	<b>Y52</b> • and specified output, CT .. °C or SA .... m above sea level											✓	✓	✓	✓	✓	✓

For legend, see Page 2/110, for footnotes, see Page 2/111.

# IEC Squirrel-Cage Motors

## Standard motors up to frame size 315 L

### Special versions

Special versions	Additional identification code <b>-Z</b> with order code and plain text if required	Motor type frame size														
		56	63	71	80	90	100	112	132	160	180	200	225	250	280	315
<b>Self-ventilated energy-saving motors with high efficiency – Cast-iron series 1LG6</b>																
<b>1LG6 (cast-iron)</b>																
<b>Colors and paint finish</b>																
Standard finish in RAL 7030 stone gray											□	□	□	□	□	□
Standard finish in other standard RAL colors: RAL 1002, 1013, 1015, 1019, 2003, 2004, 3000, 3007, 5007, 5009, 5010, 5012, 5015, 5017, 5018, 5019, 6011, 6019, 6021, 7000, 7001, 7004, 7011, 7016, 7022, 7031, 7032, 7033, 7035, 9001, 9002, 9005 Page 0/18	<b>Y53 •</b> and standard finish RAL ....										✓	✓	✓	✓	✓	✓
Special finish in RAL 7030 stone gray	<b>K26</b>										✓	✓	✓	✓	✓	✓
Special finish in other standard RAL colors: RAL 1002, 1013, 1015, 1019, 2003, 2004, 3000, 3007, 5007, 5009, 5010, 5012, 5015, 5017, 5018, 5019, 6011, 6019, 6021, 7000, 7001, 7004, 7011, 7016, 7022, 7031, 7032, 7033, 7035, 9001, 9002, 9005 Page 0/18	<b>Y54 •</b> and special finish RAL ....										✓	✓	✓	✓	✓	✓
Special finish in special RAL colors: For RAL colors, see "Special finish in special RAL colors" on Page 0/19	<b>Y51 •</b> and special finish RAL ....										✓	✓	✓	✓	✓	✓
Offshore special finish	<b>M91</b>										✓	✓	✓	✓	✓	✓
Sea air resistant special finish	<b>M94</b>										O. R.	O. R.	O. R.	O. R.	O. R.	O. R.
Unpainted (only cast iron parts primed)	<b>K23</b>										○	○	○	○	○	○
Unpainted, only primed	<b>K24</b>										✓	✓	✓	✓	✓	✓
<b>Modular technology – Basic versions <sup>5)</sup></b>																
Mounting of separately driven fan <sup>6)</sup>	<b>G17</b>										✓	✓	✓	✓	✓	✓
Mounting of brake <sup>6) 7)</sup>	<b>G26</b>										✓	✓	✓	✓	✓	✓
Mounting of 1XP8 001-1 (HTL) rotary pulse encoder	<b>H57</b>										✓	✓	✓	✓	✓	✓
Mounting of 1XP8 001-2 (TTL) rotary pulse encoder	<b>H58</b>										✓	✓	✓	✓	✓	✓
<b>Modular technology – Combinations of basic versions <sup>5)</sup></b>																
Mounting of separately driven fan and 1XP8 001-1 rotary pulse encoder	<b>H61</b>										✓	✓	✓	✓	✓	✓
Mounting of brake and 1XP8 001-1 rotary pulse encoder <sup>7)</sup>	<b>H62</b>										✓	✓	✓	✓	✓	✓
Mounting of brake and separately driven fan <sup>6) 7)</sup>	<b>H63</b>										✓	✓	✓	✓	✓	✓
Mounting of brake, separately driven fan and 1XP8 001-1 rotary pulse encoder <sup>7)</sup>	<b>H64</b>										✓	✓	✓	✓	✓	✓
Mounting of separately driven fan and 1XP8 001-2 rotary pulse encoder	<b>H97</b>										✓	✓	✓	✓	✓	✓
Mounting of brake and 1XP8 001-2 rotary pulse encoder <sup>7)</sup>	<b>H98</b>										✓	✓	✓	✓	✓	✓
Mounting of brake, separately driven fan and 1XP8 001-2 rotary pulse encoder <sup>7)</sup>	<b>H99</b>										✓	✓	✓	✓	✓	✓

# IEC Squirrel-Cage Motors

## Standard motors up to frame size 315 L

### Special versions

Special versions	Additional identification code <b>-Z</b> with order code and plain text if required	Motor type frame size															
		56	63	71	80	90	100	112	132	160	180	200	225	250	280	315	
<b>Self-ventilated energy-saving motors with high efficiency – Cast-iron series 1LG6</b>																	
<b>1LG6 (cast-iron)</b>																	
<b>Modular technology – Additional versions</b>																	
Brake supply voltage 24 V DC	<b>C00</b>											✓	✓	✓	✓	✓	✓
Brake supply voltage 400 V AC	<b>C01</b>											✓	✓	✓	✓	✓	✓
Mechanical manual brake release with lever (no locking)	<b>K82</b>											✓	✓	✓	✓	✓	✓
<b>Special technology <sup>5)</sup></b>																	
Mounting of LL 861 900 220 rotary pulse encoder	<b>H70</b>											✓	✓	✓	✓	✓	✓
Mounting of HOG 9 D 1024 I rotary pulse encoder	<b>H72</b>											✓	✓	✓	✓	✓	✓
Mounting of HOG 10 D 1024 I rotary pulse encoder	<b>H73</b>											✓	✓	✓	✓	✓	✓
Prepared for mounting LL 861 900 220	<b>H78</b>											✓	✓	✓	✓	✓	✓
Prepared for mounting HOG 9 D 1024 I	<b>H79</b>											✓	✓	✓	✓	✓	✓
Prepared for mounting HOG 10 D 1024 I	<b>H80</b>											✓	✓	✓	✓	✓	✓
Mounting of explosion-proof rotary pulse encoder HOG 10 DN 1024 I, connection box protection against moisture	<b>J15</b>											✓	✓	✓	✓	✓	✓
Mounting of explosion-proof rotary pulse encoder HOG 10 DN 1024 I, connection box protection against dust	<b>J16</b>											✓	✓	✓	✓	✓	✓
Mounting of rotary pulse encoder HOG 10 DN 1024 I + FSL, (speed .... rpm), connection box protection against moisture	<b>Y74 •</b> and specified speed .... rpm											✓	✓	✓	✓	✓	✓
Mounting of rotary pulse encoder HOG 10 DN 1024 I + FSL, (speed .... rpm), connection box protection against dust	<b>Y76 •</b> and specified speed .... rpm											✓	✓	✓	✓	✓	✓
Mounting of rotary pulse encoder HOG 10 DN 1024 I + ESL 93, (speed .... rpm), connection box protection against dust	<b>Y79 •</b> and specified speed (max. 3) .... rpm											✓	✓	✓	✓	✓	✓
<b>Mechanical design and degrees of protection</b>																	
Drive-end seal for flange-mounting motors with an oil-tightness of up to 0.1 bar. Not possible for IM V3 type of construction and 2-pole motors <sup>8)</sup>	<b>K17</b>											✓	✓	✓	✓	✓	✓
Low-noise version for 2-pole motors with clockwise direction of rotation <sup>9)</sup>	<b>K37</b>											–	–	–	–	–	–
Low-noise version for 2-pole motors with clockwise direction of rotation <sup>9)</sup>	<b>K38</b>											–	–	–	–	–	–
IP65 degree of protection <sup>10)</sup>	<b>K50</b>											✓	✓	✓	✓	✓	✓
IP56 degree of protection (non-heavy-sea) <sup>11)</sup>	<b>K52</b>											✓	✓	✓	✓	✓	✓
Condensation drainage holes <sup>12)</sup>	<b>L12</b>											□	□	□	□	□	□
Non-rusting screws (externally)	<b>M27</b>											✓	✓	✓	✓	✓	✓
Earth brushes for converter-fed operation	<b>M44</b>											–	–	–	–	O. R.	O. R.
Mechanical protection for encoder <sup>13)</sup>	<b>M68</b>											✓	✓	✓	✓	✓	✓

For legend, see Page 2/110, for footnotes, see Page 2/111.

# IEC Squirrel-Cage Motors

## Standard motors up to frame size 315 L

### Special versions

Special versions	Additional identification code <b>-Z</b> with order code and plain text if required	Motor type frame size															
		56	63	71	80	90	100	112	132	160	180	200	225	250	280	315	
<b>Self-ventilated energy-saving motors with high efficiency – Cast-iron series 1LG6</b>																	
<b>1LG6 (cast-iron)</b>																	
<b>Coolant temperature and site altitude</b>																	
Coolant temperature –50 to +40 °C	<b>D02</b>											✓	✓	✓	✓	✓	✓
Coolant temperature –40 to +40 °C	<b>D03</b>											✓	✓	✓	✓	✓	✓
Coolant temperature –30 to +40 °C	<b>D04</b>											✓	✓	✓	✓	✓	✓
<b>Designs in accordance with standards and specifications</b>																	
Electrical according to NEMA MG1-12 <sup>14)</sup>	<b>D30</b>											□	□	□	□	□	□
Design according to UL with "Recognition Mark" <sup>15)</sup>	<b>D31</b>											✓	✓	✓	✓	✓	✓
Certified for Korea according to KS C4202 <sup>16)</sup>	<b>D33</b>											✓	✓	✓	✓	✓	✓
Canadian regulations (CSA) <sup>17)</sup>	<b>D40</b>											✓	✓	✓	✓	✓	✓
VIK version (includes Zone 2 for mains-fed operation, without Ex nA II on rating plate)	<b>K30</b>											✓	✓	✓	✓	✓	✓
<b>Bearings and lubrication</b>																	
Measuring nipple for SPM shock pulse measurement for bearing inspection	<b>G50</b>											✓	✓	✓	✓	✓	✓
Bearing design for increased cantilever forces <sup>18)</sup>	<b>K20</b>											✓	✓	✓	✓	✓	✓
Special bearing for DE and NDE, bearing size 63	<b>K36</b>											✓	✓	✓	✓	✓ <sup>19)</sup>	✓ <sup>19)</sup>
Regreasing device	<b>K40</b>											✓	✓	✓	✓	□	□
Located bearing DE	<b>K94</b>											✓	✓	✓	✓	✓	✓
Located bearing NDE	<b>L04</b>											□	□	□	□	□	□
Insulated bearing cartridge	<b>L27</b>											–	–	✓	✓	✓	✓
<b>Balance and vibration quantity</b>																	
Vibration quantity A												□	□	□	□	□	□
Vibration quantity B	<b>K02</b>											✓	✓	✓	✓	✓	✓
Full key balancing	<b>L68</b>											✓	✓	✓	✓	✓	✓
Balancing without key	<b>M37</b>											✓	✓	✓	✓	✓	✓
<b>Shaft and rotor</b>																	
Concentricity of shaft extension, coaxiality and linear movement in accordance with DIN 42955 Tolerance R for flange-mounting motors <sup>20)</sup>	<b>K04</b>											✓	✓	✓	✓	✓	✓
Second standard shaft extension <sup>21)</sup>	<b>K16</b>											✓	✓	✓	✓	✓	✓
Shaft extension with normal dimensions without featherkey way	<b>K42</b>											✓	✓	✓	✓	✓	✓
Concentricity of shaft extension in accordance with DIN 42955 Tolerance R	<b>L39</b>											✓	✓	✓	✓	✓	✓
Non-standard cylindrical shaft extension <sup>22)</sup>	<b>Y55 •</b> and identification code											✓	✓	✓	✓	✓	✓
<b>Heating and ventilation</b>																	
Metal external fan <sup>23)</sup>	<b>K35</b>											✓	✓	✓	✓	✓	✓
Anti-condensation heaters for 230 V	<b>K45</b>											✓	✓	✓	✓	✓	✓
Anti-condensation heaters for 115 V	<b>K46</b>											✓	✓	✓	✓	✓	✓
Sheet metal fan cover	<b>L36</b>											✓	✓	✓	✓	✓	✓
Separately driven fan with non-standard voltage and/or frequency	<b>Y81 •</b> and identification code											–	–	✓	✓	✓	✓

For legend, see Page 2/110, for footnotes, see Page 2/111.

# IEC Squirrel-Cage Motors

## Standard motors up to frame size 315 L

### Special versions

Special versions	Additional identification code <b>-Z</b> with order code and plain text if required	Motor type frame size														
		56	63	71	80	90	100	112	132	160	180	200	225	250	280	315
<b>Self-ventilated energy-saving motors with high efficiency – Cast-iron series 1LG6</b>																
<b>Rating plate and extra rating plates</b>																
Second lubricating plate, supplied loose	<b>B06</b>										✓	✓	✓	✓	✓	✓
Second rating plate, loose	<b>K31</b>										✓	✓	✓	✓	✓	✓
Extra rating plate or rating plate with deviating rating plate data	<b>Y80 •</b> and identification codes										✓	✓	✓	✓	✓	✓
Extra rating plate with identification codes	<b>Y82 •</b> and identification code										✓	✓	✓	✓	✓	✓
Additional information on rating plate and on package label (maximum of 20 characters)	<b>Y84 •</b> and identification code										✓	✓	✓	✓	✓	✓
<b>Packaging, safety notes and test certificates</b>																
Acceptance test certificate 3.1 according to EN 10204	<b>B02</b>										✓	✓	✓	✓	✓	✓
Operating instructions German/English enclosed in print	<b>B23</b>										✓	✓	✓	✓	✓	✓
Type test with heat run for vertical motors, with acceptance	<b>F83</b>										✓	✓	✓	✓	✓	✓
Connected in star for dispatch	<b>M32</b>										✓	✓	✓	✓	✓	✓
Connected in delta for dispatch	<b>M33</b>										✓	✓	□	□	□	□

- Standard version
- Without additional charge
- This order code only determines the price of the version – Additional plain text is required.
- R. Possible on request
- ✓ With additional charge
- Not possible



# IEC Squirrel-Cage Motors

## Standard motors up to frame size 315 L

### Special versions

- 1) Evaluation with appropriate tripping unit (see Catalog LV 1) is recommended.
- 2) In combination with the PTC thermistor option or anti-condensation heating option, please inquire before ordering.
- 3) Possible in combination with order code **L44** to **L49** or length specification in plain text.
- 4) Only the 50 Hz data are indicated on the rating plate.
- 5) A second shaft extension is not possible. Please inquire for mounted brakes. The order codes listed cannot be combined within the various technologies nor with each other within the same technology system. This applies for:
  - Modular technology
  - Basic versions of "Modular technology"
  - Combination of special versions
 Exception: For frame size 225 and above, the options for mounting a brake (order code **G26**), separately driven fan (order code **G17**) or brake and separately driven fan (order code **H63**) can be combined with the options or rotary pulse encoders of the "Special technology" range.
- 6) For 1LG4/1LG6 motors, order codes **G17**, **G26** and **H63** frame size 225 and above can also be combined with all rotary pulse encoders in the "Special technology" range.
- 7) The standard brake supply voltage is 230 V AC, 50/60 Hz. Other brake supply voltages are possible with order codes **C00** and **C01**.
- 8) Not possible for motor series 1LG6 for 2-pole motors.
- 9) Not necessary for 1LG6 motors because these motors are already noise optimized.
- 10) Not possible in combination with rotary pulse encoder HOG 9 D 1024I (order code **H72**, **H79**) and/or brake 2LM8 (used for motors up to and including frame size 225, order code **G26**).
- 11) Not possible in combination with brake 2LM8 (used for motors up to and including frame size 225, order code **G26**).
- 12) Supplied with the condensation drainage holes sealed at the drive end DE and non-drive end NDE (IP55, IP56, IP65). If condensation drainage holes are required in motors of the IM B6, IM B7 or IM B8 type of construction (feet located on side or top), it is necessary to relocate the bearing plates at the drive end (DE) and non-drive end (NDE) so that the condensation drainage holes situated between the feet on delivery are underneath.
- 13) Not necessary when a rotary pulse encoder is combined with a separately driven fan, because in this case the rotary pulse encoder is installed under the fan cowl.
- 14) For the EPACT standard version (no order code required).
- 15) Possible up to 600 V max. Order with voltage code **9** and order code for voltage and frequency. The rated voltage is indicated on the rating plate.
- 16) For Korea are certified:
  - 2-pole motors  $\leq 0.75$  kW
  - 4-pole motors  $\leq 0.75$  kW
  - 6-pole motors  $\leq 0.75$  kW
- 17) Order with voltage code **9** and order code for voltage and frequency. The rated voltage is indicated on the rating plate.
- 18) Not possible for 2-pole 1LG6 motors, frame size 315 L in vertical types of construction; bearings for increased cantilever forces at vibration quantity level B available on request for 1LG6 motors. Not possible for 1LG6 motors in the combination "Concentricity of the shaft extension, coaxiality and linear movement in accordance with DIN 42955 Tolerance R for flange-mounting motors" – order code **K04**.
- 19) Extra charge for 2-pole motors. With 4-pole to 8-pole motors, standard version.
- 20) Can be combined with deep-groove bearings of series 60.., 62.. and 63... Not possible in combination with parallel roller bearings (e.g. bearings for increased cantilever forces, order code **K20**), brake mounting or encoder mounting.
- 21) Possible for motors of frame size 315 and above in vertical types of construction or 2-pole for version with second shaft extension on request. Version with protective cover not possible.
- 22) When motors are ordered that have a longer or shorter shaft extension than normal, the required position and length of the featherkey way must be specified in a sketch. It must be ensured that only featherkeys in accordance with DIN 6885, Form A are permitted to be used. The featherkey way is positioned centrally on the shaft extension. The length is defined by the manufacturer normatively. Not valid for: Conical shafts, non-standard threaded journals, non-standard shaft tolerances, friction welded journals, extremely "thin" shafts, special geometry dimensions (e.g. square journals), hollow shafts. Valid for non-standard shaft extensions DE or NDE. The featherkeys are supplied in every case. For order codes **Y55** and **K16**:
  - Dimensions D and DA  $\leq$  internal diameter of roller bearing (see dimension tables under "Dimensions")
  - Dimensions E and EA  $\leq 2 \times$  length E (normal) of the shaft extension (For an explanation of the order codes, see catalog part 0 "Introduction").
- 23) For 1LA5/6/7/9 motors and 1LG with metal external fan, converter-fed operation is permitted. The metal external fan is not possible in combination with the low-noise version – order code **K37** or **K38**.

# IEC Squirrel-Cage Motors

## Standard motors up to frame size 315 L

### Special versions

Options or order codes (supplement **-Z** is required)

Special versions	Additional identification code <b>-Z</b> with order code and plain text if required	Motor type frame size														
		56	63	71	80	90	100	112	132	160	180	200	225	250	280	315
<b>Self-cooled motors without external fan – Aluminum series 1LP7 and 1LP5</b>																
			<b>1LP7 (aluminum)</b>								<b>1LP5 (aluminum)</b>					
<b>Motor protection</b>																
Motor protection with PTC thermistors with 3 embedded temperature sensors for tripping <sup>1)</sup>	<b>A11</b>		✓	✓	✓	✓	✓	✓	✓	✓	✓	✓	✓	✓	✓	✓
Motor protection with PTC thermistors with 6 embedded temperature sensors for tripping and alarm <sup>1)</sup>	<b>A12</b>		✓	✓	✓	✓	✓	✓	✓	✓	✓	✓	✓	✓	✓	✓
Motor temperature detection with embedded temperature sensor KTY 84-130 <sup>1)</sup>	<b>A23</b>		✓	✓	✓	✓	✓	✓	✓	✓	✓	✓	✓	✓	✓	✓
Motor temperature detection with embedded temperature sensors 2 x KTY 84-130 <sup>1)</sup>	<b>A25</b>		✓	✓	✓	✓	✓	✓	✓	✓	✓	✓	✓	✓	✓	✓
Temperature detectors for tripping <sup>1)</sup>	<b>A31</b>		✓	✓	✓	✓	✓	✓	✓	✓	✓	✓	✓	✓	✓	✓
Installation of 3 PT 100 resistance thermometers <sup>1)</sup>	<b>A60</b>		–	–	–	–	–	✓	✓	✓	✓	✓	✓	✓	✓	✓
<b>Motor connection and connection box</b>																
ECOFAST motor plug Han-Drive 10e for 230 VΔ/400 VY <sup>2)</sup>	<b>G55</b>		✓	✓	✓	✓	✓	✓	✓	✓	–	–	–	–	–	–
ECOFAST motor plug EMC Han-Drive 10e for 230 VΔ/400 VY <sup>3)</sup>	<b>G56</b>		✓	✓	✓	✓	✓	✓	✓	✓	–	–	–	–	–	–
Connection box on RHS	<b>K09</b>		–	–	✓	✓	✓	✓	✓	✓	✓	✓	✓	✓	✓	✓
Connection box on LHS	<b>K10</b>		–	–	✓	✓	✓	✓	✓	✓	✓	✓	✓	✓	✓	✓
One cable gland, metal	<b>K54</b>		✓	✓	✓	✓	✓	✓	✓	✓	✓	✓	✓	✓	✓	✓
Cable gland, maximum configuration	<b>K55</b>		✓	✓	✓	✓	✓	✓	✓	✓	✓	✓	✓	✓	✓	✓
Rotation of the connection box through 90°, entry from DE	<b>K83</b>		✓	✓	✓	✓	✓	✓	✓	✓	✓	✓	✓	✓	✓	✓
Rotation of the connection box through 90°, entry from NDE	<b>K84</b>		✓	✓	✓	✓	✓	✓	✓	✓	✓	✓	✓	✓	✓	✓
Rotation of connection box through 180°	<b>K85</b>		✓	✓	✓	✓	✓	○	○	○	○	✓	✓	✓	✓	✓
Next larger connection box	<b>L00</b>		–	–	–	–	–	–	–	–	–	–	✓	✓	✓	✓
External earthing	<b>L13</b>		✓	✓	✓	✓	✓	✓	✓	✓	✓	✓	✓	✓	✓	✓
3 cables protruding, 0.5 m long <sup>4)</sup>	<b>L44</b>		✓	✓	✓	✓	✓	✓	✓	✓	✓	✓	O. R.	O. R.	–	–
3 cables protruding, 1.5 m long <sup>4)</sup>	<b>L45</b>		✓	✓	✓	✓	✓	✓	✓	✓	✓	✓	O. R.	O. R.	–	–
6 cables protruding, 0.5 m long <sup>4)</sup>	<b>L47</b>		✓	✓	✓	✓	✓	✓	✓	✓	✓	✓	O. R.	O. R.	–	–
6 cables protruding, 1.5 m long <sup>4)</sup>	<b>L48</b>		✓	✓	✓	✓	✓	✓	✓	✓	✓	✓	✓	✓	✓	✓
6 cables protruding, 3 m long <sup>5)</sup>	<b>L49</b>		–	–	–	–	–	–	–	–	–	–	–	–	–	–
Connection box on NDE	<b>M64</b>		✓	✓	✓	✓	✓	✓	✓	✓	✓	✓	✓	✓	✓	✓
Terminal strip for main and auxiliary terminals	<b>M69</b>		✓	✓	✓	✓	–	–	–	–	–	–	–	–	–	–
<b>Windings and insulation</b>																
Increased air humidity/temperature with 30 to 60 g water per m <sup>3</sup> of air	<b>C19</b>		✓	✓	✓	✓	✓	✓	✓	✓	✓	✓	✓	✓	✓	✓
Increased air humidity/temperature with 60 to 100 g water per m <sup>3</sup> of air	<b>C26</b>		✓	✓	✓	✓	✓	✓	✓	✓	✓	✓	✓	✓	✓	✓

For legend, see Page 2/114, for footnotes, see Page 2/115.

# IEC Squirrel-Cage Motors

## Standard motors up to frame size 315 L

### Special versions

Special versions	Additional identification code <b>-Z</b> with order code and plain text if required	Motor type frame size														
		56	63	71	80	90	100	112	132	160	180	200	225	250	280	315
<b>Self-cooled motors without external fan – Aluminum series 1LP7 and 1LP5</b>																
			<b>1LP7 (aluminum)</b>								<b>1LP5 (aluminum)</b>					
<b>Colors and paint finish</b>																
Special finish in RAL 7030 stone gray			☐	☐	☐	☐	☐	☐	☐	☐	☐	☐	☐	☐	☐	☐
Special finish in other standard RAL colors: RAL 1002, 1013, 1015, 1019, 2003, 2004, 3000, 3007, 5007, 5009, 5010, 5012, 5015, 5017, 5018, 5019, 6011, 6019, 6021, 7000, 7001, 7004, 7011, 7016, 7022, 7031, 7032, 7033, 7035, 9001, 9002, 9005 Page 0/18	<b>Y54 •</b> and special finish RAL ....		✓	✓	✓	✓	✓	✓	✓	✓	✓	✓	✓	✓	✓	✓
Special finish in special RAL colors: For RAL colors, see "Special finish in special RAL colors" on Page 0/19	<b>Y51 •</b> and special finish RAL ....		✓	✓	✓	✓	✓	✓	✓	✓	✓	✓	✓	✓	✓	✓
Standard finish in other standard RAL colors: RAL 1002, 1013, 1015, 1019, 2003, 2004, 3000, 3007, 5007, 5009, 5010, 5012, 5015, 5017, 5018, 5019, 6011, 6019, 6021, 7000, 7001, 7004, 7011, 7016, 7022, 7031, 7032, 7033, 7035, 9001, 9002, 9005 Page 0/18	<b>Y53 •</b> and standard finish RAL ....		–	–	–	–	–	–	–	–	–	–	–	–	–	–
Sea air resistant special finish	<b>M94</b>		O. R.	O. R.	O. R.	O. R.	O. R.	O. R.	O. R.	O. R.	O. R.	O. R.	O. R.	O. R.	O. R.	O. R.
Unpainted (only cast iron parts primed)	<b>K23</b>		○	○	○	○	○	○	○	○	○	○	○	○	○	○
Unpainted, only primed	<b>K24</b>		✓	✓	✓	✓	✓	✓	✓	✓	✓	✓	✓	✓	✓	✓
<b>Mechanical design and degrees of protection</b>																
Drive-end seal for flange-mounting motors with an oil-tightness of up to 0.1 bar <sup>5)</sup>	<b>K17</b>		✓	✓	✓	✓	✓	✓	✓	✓	✓	✓	✓	✓	✓	✓
With two additional eyebolts for IM V1/IM V3	<b>K32</b>		–	–	–	–	–	–	–	–	–	–	–	–	–	–
IP65 degree of protection	<b>K50</b>		✓	✓	✓	✓	✓	✓	✓	✓	✓	✓	✓	✓	✓	✓
IP56 degree of protection (non-heavy-sea)	<b>K52</b>		✓	✓	✓	✓	✓	✓	✓	✓	✓	✓	✓	✓	✓	✓
Vibration-proof version	<b>L03</b>		✓	✓	✓	✓	✓	✓	✓	✓	✓	✓	✓	✓	✓	✓
Condensation drainage holes <sup>6)</sup>	<b>L12</b>		✓	✓	✓	✓	✓	✓	✓	✓	✓	✓	✓	✓	✓	✓
Non-rusting screws (externally)	<b>M27</b>		✓	✓	✓	✓	✓	✓	✓	✓	✓	✓	✓	✓	✓	✓
<b>Coolant temperature and site altitude</b>																
Coolant temperature –40 to +40 °C	<b>D03</b>		✓	✓	✓	✓	✓	✓	✓	✓	✓	✓	✓	✓	✓	✓
Coolant temperature –30 to +40 °C	<b>D04</b>		✓	✓	✓	✓	✓	✓	✓	✓	✓	✓	✓	✓	✓	✓
<b>Designs in accordance with standards and specifications</b>																
Design according to UL with "Recognition Mark" <sup>7)</sup>	<b>D31</b>		✓	✓	✓	✓	✓	✓	✓	✓	✓	✓	✓	✓	✓	✓
Canadian regulations (CSA) <sup>8)</sup>	<b>D40</b>		✓	✓	✓	✓	✓	✓	✓	✓	✓	✓	✓	✓	✓	✓
PSE Mark Japan <sup>9)</sup>	<b>D46</b>		✓	✓	✓	✓	✓	✓	✓	✓	✓	–	–	–	–	–
<b>Bearings and lubrication</b>																
Measuring nipple for SPM shock pulse measurement for bearing inspection	<b>G50</b>		–	–	–	–	–	✓	✓	✓	✓	✓	✓	✓	✓	✓
Bearing design for increased cantilever forces	<b>K20</b>		–	–	–	–	–	✓	✓	✓	✓	✓	✓	✓	✓	✓
Regreasing device	<b>K40</b>		–	–	–	–	–	✓	✓	✓	✓	✓	✓	✓	✓	✓
Located bearing DE	<b>K94</b>		✓	✓	✓	✓	✓	✓	✓	✓	✓	✓	✓	✓	✓	✓
Located bearing NDE	<b>L04</b>		✓	✓	✓	✓	✓	✓	✓	✓	✓	☐	☐	☐	☐	☐

# IEC Squirrel-Cage Motors

## Standard motors up to frame size 315 L

### Special versions

Special versions	Additional identification code <b>-Z</b> with order code and plain text if required	Motor type frame size														
		56	63	71	80	90	100	112	132	160	180	200	225	250	280	315
<b>Self-cooled motors without external fan – Aluminum series 1LP7 and 1LP5</b>																
			<b>1LP7 (aluminum)</b>								<b>1LP5 (aluminum)</b>					
<b>Balance and vibration quantity</b>																
Vibration quantity A			☐	☐	☐	☐	☐	☐	☐	☐	☐	☐	☐	☐	☐	☐
Vibration quantity B	<b>K02</b>		✓	✓	✓	✓	✓	✓	✓	✓	✓	✓	✓	✓	✓	✓
Full key balancing	<b>L68</b>		✓	✓	✓	✓	✓	✓	✓	✓	✓	✓	✓	✓	✓	✓
Balancing without key	<b>M37</b>		✓	✓	✓	✓	✓	✓	✓	✓	✓	✓	✓	✓	✓	✓
<b>Shaft and rotor</b>																
Concentricity of shaft extension, coaxiality and linear movement in accordance with DIN 42955 Tolerance R for flange-mounting motors <sup>10)</sup>	<b>K04</b>		✓	✓	✓	✓	✓	✓	✓	✓	✓	✓	✓	✓	✓	✓
Second standard shaft extension	<b>K16</b>		✓	✓	✓	✓	✓	✓	✓	✓	✓	✓	✓	✓	✓	✓
Shaft extension with normal dimensions without featherkey way	<b>K42</b>		✓	✓	✓	✓	✓	✓	✓	✓	✓	✓	✓	✓	✓	✓
Concentricity of shaft extension in accordance with DIN 42955 Tolerance R	<b>L39</b>		✓	✓	✓	✓	✓	✓	✓	✓	✓	✓	✓	✓	✓	✓
Standard shaft made of non-rusting steel	<b>M65</b>		–	–	✓	✓	✓	✓	✓	✓	✓	✓	✓	✓	✓	✓
Non-standard cylindrical shaft extension <sup>11)</sup>	<b>Y55 •</b> and identification code		✓	✓	✓	✓	✓	✓	✓	✓	✓	✓	✓	✓	✓	✓
<b>Heating and ventilation</b>																
Anti-condensation heaters for 230 V	<b>K45</b>		✓	✓	✓	✓	✓	✓	✓	✓	✓	✓	✓	✓	✓	✓
Anti-condensation heaters for 115 V	<b>K46</b>		✓	✓	✓	✓	✓	✓	✓	✓	✓	✓	✓	✓	✓	✓
<b>Rating plate and extra rating plates</b>																
Second lubricating plate, supplied loose	<b>B06</b>		–	–	–	–	✓	✓	✓	✓	✓	✓	✓	✓	✓	✓
Second rating plate, loose	<b>K31</b>		✓	✓	✓	✓	✓	✓	✓	✓	✓	✓	✓	✓	✓	✓
Extra rating plate or rating plate with deviating rating plate data	<b>Y80 •</b> and identification code		✓	✓	✓	✓	✓	✓	✓	✓	✓	✓	✓	✓	✓	✓
Extra rating plate with identification codes	<b>Y82 •</b> and identification code		✓	✓	✓	✓	✓	✓	✓	✓	✓	✓	✓	✓	✓	✓
Additional information on rating plate and on package label (maximum of 20 characters)	<b>Y84 •</b> and identification code		✓	✓	✓	✓	✓	✓	✓	✓	✓	✓	✓	✓	✓	✓
<b>Packaging, safety notes and test certificates</b>																
Without safety and commissioning note. Customer's declaration of renouncement required.	<b>B00</b>		–	○	○	○	○	○	○	○	○	○	○	○	○	○
With one safety and startup guide per box pallet	<b>B01</b>		–	○	○	○	○	○	○	○	○	○	○	○	○	○
Acceptance test certificate 3.1 according to EN 10204	<b>B02</b>		✓	✓	✓	✓	✓	✓	✓	✓	✓	✓	✓	✓	✓	✓
Operating instructions German/English in print	<b>B23</b>		✓	✓	✓	✓	✓	✓	✓	✓	✓	✓	✓	✓	✓	✓
Type test with heat run for vertical motors, with acceptance	<b>F83</b>		✓	✓	✓	✓	✓	✓	✓	✓	✓	✓	✓	✓	✓	✓
Wire-lattice pallet	<b>L99</b>		○	○	○	○	○	○	○	○	○	○	○	○	○	○
Connected in star for dispatch	<b>M32</b>		✓	✓	✓	✓	✓	✓	✓	✓	✓	✓	✓	✓	✓	✓
Connected in delta for dispatch	<b>M33</b>		✓	✓	✓	✓	✓	✓	✓	✓	✓	✓	✓	✓	✓	✓

- ☐ Standard version
- Without additional charge
- This order code only determines the price of the version – Additional plain text is required.
- R. Possible on request
- ✓ With additional charge
- Not possible

For footnotes, see Page 2/115.

# IEC Squirrel-Cage Motors

## Standard motors up to frame size 315 L

**Special versions**
**2**

- 1) Evaluation with appropriate tripping unit (see Catalog LV 1) is recommended.
- 2) Only one sensor (temperature sensor or PTC thermistor) can be connected. Only possibilities are voltage code **1** with voltage of 230 VΔ/400 VY and special voltage with voltage code **9** and order code **L1U** (400 VΔ). The following order codes cannot be used in combination with the ECOFAST plugs, order code **G55: A12, C18, D31, D40, G50, H15, H17, H62, H63, H64, H98, H99, K04, K15, K16, K34, K35, K40, K45, K46, K52, K54, K82, L03, L44, L45, L47, L48, L49, L51, L52.**
- 3) Only one sensor (temperature sensor or PTC thermistor) can be connected. Only possibilities are voltage code **1** with voltage of 230 VΔ/400 VY and special voltage with voltage code **9** and order code **L1U** (400 VΔ). The following order codes cannot be used in combination with the ECOFAST plugs, order code **G56: A12, A23, A31, C00, C18, D31, D40, G50, H15, H17, H90, H91, H92, H93, H94, H95, K04, K15, K16, K34, K35, K40, K45, K46, K52, K54, K82, L03, L44, L45, L47, L48, L49, L51, L52.**
- 4) In combination with the PTC thermistor option or anti-condensation heating option, please inquire before ordering.
- 5) Not possible for type of construction IM V3.
- 6) Supplied with the condensation drainage holes sealed at the drive end DE and non-drive end NDE (IP55, IP56, IP65). If condensation drainage holes are required in motors of the IM B6, IM B7 or IM B8 type of construction (feet located on side or top), it is necessary to relocate the bearing plates at the drive end (DE) and non-drive end (NDE) so that the condensation drainage holes situated between the feet on delivery are underneath.
- 7) Possible up to 600 V max. The rated voltage is indicated on the rating plate without voltage range.
- 8) The rated voltage is indicated on the rating plate without voltage range.
- 9) "Small power motors" with a rated output of up to 3 kW which are exported to Japan must bear the PSE marking.
- 10) Can be combined with deep-groove bearings of series 60... 62... and 63... Not possible in combination with parallel roller bearings (e.g. bearings for increased cantilever forces, order code **K20**).
- 11) When motors are ordered that have a longer or shorter shaft extension than normal, the required position and length of the featherkey way must be specified in a sketch. It must be ensured that only featherkeys in accordance with DIN 6885, Form A are permitted to be used. The featherkey way is positioned centrally on the shaft extension. The length is defined by the manufacturer normatively. Not valid for: Conical shafts, non-standard threaded journals, non-standard shaft tolerances, friction welded journals, extremely "thin" shafts, special geometry dimensions (e.g. square journals), hollow shafts. Valid for non-standard shaft extensions DE or NDE. The featherkeys are supplied in every case. For order codes **Y55** and **K16**:
  - Dimensions D and DA ≤ internal diameter of roller bearing (see dimension tables under "Dimensions")
  - Dimensions E and EA ≤ 2 x length E (normal) of the shaft extension
 For an explanation of the order codes, see catalog part 0 "Introduction".

# IEC Squirrel-Cage Motors

## Standard motors up to frame size 315 L

### Special versions

Options or order codes (supplement **-Z** is required)

Special versions	Additional identification code <b>-Z</b> with order code and plain text if required	Motor type frame size															
		56	63	71	80	90	100	112	132	160	180	200	225	250	280	315	
<b>Self-cooled motors without external fan – Cast-iron series 1LP4</b>																	
<b>Motor protection</b>																	
Motor protection with PTC thermistors with 3 embedded temperature sensors for tripping <sup>1)</sup>	<b>A11</b>											✓	✓	✓	✓	✓	✓
Motor protection with PTC thermistors with 6 embedded temperature sensors for tripping and alarm <sup>1)</sup>	<b>A12</b>											✓	✓	✓	✓	✓	✓
Motor temperature detection with embedded temperature sensor KTY 84-130 <sup>1)</sup>	<b>A23</b>											✓	✓	✓	✓	✓	✓
Motor temperature detection with embedded temperature sensors 2 x KTY 84-130 <sup>1)</sup>	<b>A25</b>											✓	✓	✓	✓	✓	✓
Temperature detectors for tripping <sup>1)</sup>	<b>A31</b>											✓	✓	✓	✓	✓	✓
Installation of 3 PT 100 resistance thermometers <sup>1)</sup>	<b>A60</b>											✓	✓	✓	✓	✓	✓
Installation of 6 PT 100 resistance thermometers in stator winding <sup>1)</sup>	<b>A61</b>											✓	✓	✓	✓	✓	✓
Installation of 2 PT 100 screw-in resistance thermometers (basic circuit) for rolling-contact bearings <sup>1)</sup>	<b>A72</b>											✓	✓	✓	✓	✓	✓
Installation of 2 PT100 screw-in resistance thermometers (3-wire circuit) for rolling-contact bearings <sup>1)</sup>	<b>A78</b>											✓	✓	✓	✓	✓	✓
Installation of 2 PT 100 double screw-in resistance thermometers (3-wire circuit) for rolling-contact bearings <sup>1)</sup>	<b>A80</b>											✓	✓	✓	✓	✓	✓
<b>Motor connection and connection box</b>																	
Two-part plate on connection box	<b>K06</b>											–	✓	✓	✓	✓	✓
Connection box on RHS	<b>K09</b>											✓	✓	✓	✓	✓	✓
Connection box on LHS	<b>K10</b>											✓	✓	✓	✓	✓	✓
Connection box on top, feet screwed on	<b>K11</b>											✓	✓	✓	✓	✓	✓
One cable gland, metal	<b>K54</b>											✓	✓	✓	✓	✓	✓
Cable gland, maximum configuration	<b>K55</b>											✓	✓	✓	✓	✓	✓
Rotation of the connection box through 90°, entry from DE	<b>K83</b>											✓	✓	✓	✓	✓	✓
Rotation of the connection box through 90°, entry from NDE	<b>K84</b>											✓	✓	✓	✓	✓	✓
Rotation of connection box through 180°	<b>K85</b>											✓	✓	✓	✓	✓	✓
Next larger connection box	<b>L00</b>											✓	✓	✓	✓	✓	✓
External earthing	<b>L13</b>											☐	☐	☐	☐	☐	☐
6 cables protruding, 1.5 m long <sup>2)</sup>	<b>L48</b>											✓	✓	✓	O. R.	O. R.	O. R.
6 cables protruding, 3 m long <sup>2)</sup>	<b>L49</b>											✓	✓	✓	O. R.	O. R.	O. R.
Protruding cable ends – right side <sup>3)</sup>	<b>L51</b>											O. R.	O. R.	O. R.	O. R.	O. R.	O. R.
Protruding cable ends – left side <sup>3)</sup>	<b>L52</b>											O. R.	O. R.	O. R.	O. R.	O. R.	O. R.
Auxiliary connection box 1XB3 020	<b>L97</b>											✓	✓	✓	✓	✓	✓

For legend and footnotes, see Page 2/119.

# IEC Squirrel-Cage Motors

## Standard motors up to frame size 315 L

### Special versions

Special versions	Additional identification code <b>-Z</b> with order code and plain text if required	Motor type frame size														
		56	63	71	80	90	100	112	132	160	180	200	225	250	280	315
<b>Self-cooled motors without external fan – Cast-iron series 1LP4</b>																
<b>1LP4 (cast-iron)</b>																
<b>Motor connection and connection box (continued)</b>																
Stud terminal for cable connection, accessories pack (3 items)	<b>M46</b>										–	–	–	✓	✓	✓
Saddle terminal for connection without cable lug, accessories pack (6 items)	<b>M47</b>										–	–	–	✓	✓	✓
<b>Windings and insulation</b>																
Temperature class 155 (F), used acc. to 155 (F), with service factor (SF)	<b>C11</b>										✓	✓	✓	✓	✓	✓
Temperature class 155 (F), used acc. to 155 (F), with increased output <sup>4)</sup>	<b>C12</b>										✓	✓	✓	✓	✓	✓
Temperature class 155 (F), used acc. to 155 (F), with increased coolant temperature	<b>C13</b>										✓	✓	✓	✓	✓	✓
Increased air humidity/temperature, with 30 to 60 g water per m <sup>3</sup> of air	<b>C19</b>										✓	✓	✓	✓	✓	✓
Increased air humidity/temperature, with 60 to 100 g water per m <sup>3</sup> of air	<b>C26</b>										✓	✓	✓	✓	✓	✓
Temperature class 155 (F), used acc. to 130 (B), with increased coolant temperature and/or site altitude	<b>Y50</b> • and specified output, CT .. °C or SA .... m above sea level										✓	✓	✓	✓	✓	✓
Temperature class 155 (F), used acc. to 155 (F), other requirements	<b>Y52</b> • and specified output, CT .. °C or SA .... m above sea level										✓	✓	✓	✓	✓	✓
<b>Colors and paint finish</b>																
Standard finish in RAL 7030 stone gray											□	□	□	□	□	□
Standard finish in other standard RAL colors: RAL 1002, 1013, 1015, 1019, 2003, 2004, 3000, 3007, 5007, 5009, 5010, 5012, 5015, 5017, 5018, 5019, 6011, 6019, 6021, 7000, 7001, 7004, 7011, 7016, 7022, 7031, 7032, 7033, 7035, 9001, 9002, 9005 Page 0/18	<b>Y53</b> • and standard finish RAL ....										✓	✓	✓	✓	✓	✓
Special finish in RAL 7030 stone gray	<b>K26</b>										✓	✓	✓	✓	✓	✓
Special finish in other standard RAL colors: RAL 1002, 1013, 1015, 1019, 2003, 2004, 3000, 3007, 5007, 5009, 5010, 5012, 5015, 5017, 5018, 5019, 6011, 6019, 6021, 7000, 7001, 7004, 7011, 7016, 7022, 7031, 7032, 7033, 7035, 9001, 9002, 9005 Page 0/18	<b>Y54</b> • and special finish RAL ....										✓	✓	✓	✓	✓	✓
Special finish in special RAL colors: For RAL colors, see "Special finish in special RAL colors" on Page 0/19	<b>Y51</b> • and special finish RAL ....										✓	✓	✓	✓	✓	✓
Offshore special finish	<b>M91</b>										✓	✓	✓	✓	✓	✓
Sea air resistant special finish	<b>M94</b>										O. R.	O. R.	O. R.	O. R.	O. R.	O. R.
Unpainted (only cast iron parts primed)	<b>K23</b>										○	○	○	○	○	○
Unpainted, only primed	<b>K24</b>										✓	✓	✓	✓	✓	✓

For legend and footnotes, see Page 2/119.

# IEC Squirrel-Cage Motors

## Standard motors up to frame size 315 L

### Special versions

Special versions	Additional identification code <b>-Z</b> with order code and plain text if required	Motor type frame size														
		56	63	71	80	90	100	112	132	160	180	200	225	250	280	315
<b>Self-cooled motors without external fan – Cast-iron series 1LP4</b>																
<b>1LP4 (cast-iron)</b>																
<b>Mechanical design and degrees of protection</b>																
Drive-end seal for flange-mounting motors with an oil-tightness of up to 0.1 bar Not possible for IM V3 type of construction <sup>5)</sup>	<b>K17</b>										✓	✓	✓	✓	✓	✓
IP65 degree of protection	<b>K50</b>										✓	✓	✓	✓	✓	✓
IP56 degree of protection (non-heavy-sea)	<b>K52</b>										✓	✓	✓	✓	✓	✓
Condensation drainage holes <sup>6)</sup>	<b>L12</b>										□	□	□	□	□	□
Non-rusting screws (externally)	<b>M27</b>										✓	✓	✓	✓	✓	✓
<b>Coolant temperature and site altitude</b>																
Coolant temperature -50 to +40 °C	<b>D02</b>										✓	✓	✓	✓	✓	✓
Coolant temperature -40 to +40 °C	<b>D03</b>										✓	✓	✓	✓	✓	✓
Coolant temperature -30 to +40 °C	<b>D04</b>										✓	✓	✓	✓	✓	✓
<b>Designs in accordance with standards and specifications</b>																
Design according to UL with "Recognition Mark" <sup>7)</sup>	<b>D31</b>										✓	✓	✓	✓	✓	✓
Canadian regulations (CSA) <sup>8)</sup>	<b>D40</b>										✓	✓	✓	✓	✓	✓
<b>Bearings and lubrication</b>																
Measuring nipple for SPM shock pulse measurement for bearing inspection	<b>G50</b>										✓	✓	✓	✓	✓	✓
Bearing design for increased cantilever forces <sup>9)</sup>	<b>K20</b>										✓	✓	✓	✓	✓	✓
Special bearing for DE and NDE, bearing size	<b>K36</b>										✓	✓	✓	✓	✓ <sup>10)</sup>	✓ <sup>10)</sup>
Regreasing device	<b>K40</b>										✓	✓	✓	✓	□	□
Located bearing DE	<b>K94</b>										✓	✓	✓	✓	✓	✓
Located bearing NDE	<b>L04</b>										□	□	□	□	□	□
Insulated bearing cartridge	<b>L27</b>										-	-	✓	✓	✓	✓
<b>Balance and vibration quantity</b>																
Vibration quantity A											□	□	□	□	□	□
Vibration quantity B	<b>K02</b>										✓	✓	✓	✓	✓	✓
Full key balancing	<b>L68</b>										✓	✓	✓	✓	✓	✓
Balancing without key	<b>M37</b>										✓	✓	✓	✓	✓	✓
<b>Shaft and rotor</b>																
Concentricity of shaft extension, coaxiality and linear movement in accordance with DIN 42955 Tolerance R for flange-mounting motors <sup>11)</sup>	<b>K04</b>										✓	✓	✓	✓	✓	✓
Second standard shaft extension <sup>12)</sup>	<b>K16</b>										✓	✓	✓	✓	✓	✓
Shaft extension with normal dimensions without featherkey way	<b>K42</b>										✓	✓	✓	✓	✓	✓
Concentricity of shaft extension in accordance with DIN 42955 Tolerance R	<b>L39</b>										✓	✓	✓	✓	✓	✓
Non-standard cylindrical shaft extension <sup>13)</sup>	<b>Y55 •</b> and identification code										✓	✓	✓	✓	✓	✓
<b>Heating and ventilation</b>																
Anti-condensation heaters for 230 V	<b>K45</b>										✓	✓	✓	✓	✓	✓
Anti-condensation heaters for 115 V	<b>K46</b>										✓	✓	✓	✓	✓	✓

For legend and footnotes, see Page 2/119.



# IEC Squirrel-Cage Motors

## Standard motors up to frame size 315 L

### Special versions

Special versions	Additional identification code <b>-Z</b> with order code and plain text if required	Motor type frame size															
		56	63	71	80	90	100	112	132	160	180	200	225	250	280	315	
<b>Self-cooled motors without external fan – Cast-iron series 1LP4</b>																	
<b>Rating plate and extra rating plates</b>																	
Second lubricating plate, supplied loose	<b>B06</b>											✓	✓	✓	✓	✓	✓
Second rating plate, loose	<b>K31</b>											✓	✓	✓	✓	✓	✓
Extra rating plate or rating plate with deviating rating plate data	<b>Y80</b> • and identification code											✓	✓	✓	✓	✓	✓
Extra rating plate with identification codes	<b>Y82</b> • and identification code											✓	✓	✓	✓	✓	✓
Additional information on rating plate and on package label (maximum of 20 characters)	<b>Y84</b> • and identification code											✓	✓	✓	✓	✓	✓
<b>Packaging, safety notes, documentation and test certificates</b>																	
Acceptance test certificate 3.1 according to EN 10204	<b>B02</b>											✓	✓	✓	✓	✓	✓
Type test with heat run for vertical motors, with acceptance	<b>F83</b>											✓	✓	✓	✓	✓	✓
Connected in star for dispatch	<b>M32</b>											✓	✓	✓	✓	✓	✓
Connected in delta for dispatch	<b>M33</b>											✓	✓	□	□	□	□

- Standard version
- Without additional charge
- This order code only determines the price of the version – Additional plain text is required.
- R. Possible on request
- ✓ With additional charge
- Not possible

- 1) Evaluation with appropriate tripping unit (see Catalog LV 1) is recommended.
- 2) In combination with the PTC thermistor option or anti-condensation heating option, please inquire before ordering.
- 3) Possible in combination with order code **L44** to **L49** or length specification in plain text.
- 4) Only the 50 Hz data are indicated on the rating plate.
- 5) Not possible for motor series 1LP4 for 2-pole motors.
- 6) Supplied with the condensation drainage holes sealed at the drive end DE and non-drive end NDE (IP55, IP56, IP65). If condensation drainage holes are required in motors of the IM B6, IM B7 or IM B8 type of construction (feet located on side or top), it is necessary to relocate the bearing plates at the drive end (DE) and non-drive end (NDE) so that the condensation drainage holes situated between the feet on delivery are underneath.
- 7) Possible up to 600 V max. Order with voltage code **9** and order code for voltage and frequency. The rated voltage is indicated on the rating plate.
- 8) Order with voltage code **9** and order code for voltage and frequency. The rated voltage is indicated on the rating plate.
- 9) Not possible for 2-pole 1LP4 motors, frame size 315 L in vertical types of construction; bearings for increased cantilever forces at vibration quantity level B available on request for 1LP4 motors. Not possible for 1LP4 motors in the combination "Concentricity of the shaft extension, coaxiality and linear movement in accordance with DIN 42955 Tolerance R for flange-mounting motors" – order code **K04**.

- 10) Extra charge for 2-pole motors. With 4-pole to 8-pole motors, standard version.
- 11) Can be combined with deep-groove bearings of series 60... 62... and 63... Not possible in combination with parallel roller bearings (e.g. bearings for increased cantilever forces, order code **K20**).
- 12) Possible for motors of frame size 315 and above in vertical types of construction or 2-pole for version with second shaft extension on request. Version with protective cover not possible.
- 13) When motors are ordered that have a longer or shorter shaft extension than normal, the required position and length of the featherkey way must be specified in a sketch. It must be ensured that only featherkeys in accordance with DIN 6885, Form A are permitted to be used. The featherkey way is positioned centrally on the shaft extension. The length is defined by the manufacturer normatively. Not valid for: Conical shafts, non-standard threaded journals, non-standard shaft tolerances, friction welded journals, extremely "thin" shafts, special geometry dimensions (e.g. square journals), hollow shafts. Valid for non-standard shaft extensions DE or NDE. The featherkeys are supplied in every case. For order codes **Y55** and **K16**: – Dimensions D and DA ≤ internal diameter of roller bearing (see dimension tables under "Dimensions") – Dimensions E and EA ≤ 2 x length E (normal) of the shaft extension For an explanation of the order codes, see catalog part 0 "Introduction".

# IEC Squirrel-Cage Motors

## Standard motors up to frame size 315 L

### Accessories

#### Overview

##### Modular technology

The components of modular technology can be ordered as accessories. The brake, as a safety-related module, must not be retrofitted.

Cables for rotary pulse encoders can be ordered from Catalog DA 65.10.

#### Mounting of rotary pulse encoder and separately driven fan for 1LA5, 1LA6, 1LA7 and 1LG motors

Version	Frame size	Number of poles	Order No.
<b>Rotary pulse encoder</b> <sup>1)</sup>	HTL version	71 ... 225	<b>1XP8 001-1</b>
	TTL version	71 ... 225	<b>1XP8 001-2</b>
<b>Separately driven fan</b> incl. mounting parts <sup>2)</sup>	100	all	<b>2CW2 180-8RF54-1AB0</b>
	112	all	<b>2CW2 210-8RF54-1AB1</b>
	132	all	<b>2CW2 250-8RF54-1AB2</b>
	160	all	<b>2CW2 300-8RF54-1AB3</b>
	180	all	<b>2CW2 300-8RF54-1AB4</b>
	200	all	<b>2CW2 300-8RF54-1AB5</b>
	225 <sup>3)</sup>	all	<b>2CW2 300-8RF54-1AB6</b>
	250	all	<b>1PP9 063-2LA12-Z A11+K50<sup>4)</sup></b>
	280	all	<b>1PP9 063-2LA12-Z A11+K50<sup>4)</sup></b>
	315	2	<b>1PP9 070-2LA12-Z A11+K50<sup>4)</sup></b>
315	4 to 8	<b>1PP9 063-2LA12-Z A11+K50<sup>4)</sup></b>	
<b>Separately driven fan</b> and rotary pulse encoder 1XP8 001-1 incl. mounting parts <sup>2)</sup>	100	all	<b>2CW2 180-8RF54-2AB0</b>
	112	all	<b>2CW2 210-8RF54-2AB1</b>
	132	all	<b>2CW2 250-8RF54-2AB2</b>
	160	all	<b>2CW2 300-8RF54-2AB3</b>
	180	all	<b>2CW2 300-8RF54-2AB4</b>
	200	all	<b>2CW2 300-8RF54-2AB5</b>
225 <sup>3)</sup>	all	<b>2CW2 300-8RF54-2AB6</b>	

#### Slide rails with fixing bolts and tensioning screws acc. to DIN 42923

Slide rails are used to tension the belt of a machine easily and conveniently when a belt tightener is not available. They are fixed to the base using stone bolts or foundation blocks.

The assignment of slide rails to motor size can be found in DIN 42923. For motors of frame sizes 335 to 450, there are no standardised slide rails (please inquire).

Available from:  
Lütgert & Co. GmbH  
Postfach 42 51  
33276 Gütersloh, Germany  
Tel. +49 (0)5241-7407-0  
Fax +49 (0)5241-7407-90

<http://www.luetgert-antriebe.de>  
e-mail: [info@luetgert-antriebe.de](mailto:info@luetgert-antriebe.de)

#### Foundation block acc. to DIN 799

The foundation blocks are inserted into the stone foundation and embedded in concrete. They are used for fixing machines of medium size, slide rails, pedestal bearings, baseframes, etc. After the fixing bolts have been unscrewed, the machine can be dragged without it having to be lifted.

When the machine is initially installed, the foundation block that is bolted to the machine (without washers) and fitted with tapered pins is not embedded with concrete until the machine has been fully aligned. In this case, the machine is positioned 2 to 3 mm lower. The difference in shaft height is compensated by inserting shims on final installation. The tapered pins safeguard the exact position of the machine when it is repeatedly removed and replaced without the need for realignment.

Available from:  
Lütgert & Co. GmbH  
Postfach 42 51  
33276 Gütersloh, Germany  
Tel. +49 (0)5241-7407-0  
Fax +49 (0)5241-7407-90

<http://www.luetgert-antriebe.de>  
e-mail: [info@luetgert-antriebe.de](mailto:info@luetgert-antriebe.de)

<sup>1)</sup> For motor series 1LG, the rotary pulse encoders are available on request. They are only available for motor series 1LA7 as accessories for spare parts.

<sup>2)</sup> The separately driven fan 2CW2 ... comprises a complete fan unit with impeller, the separately driven fan 1PP9 ... only comprises the fan motor without mounting components and impeller.

<sup>3)</sup> For 1LG motors with separately driven fan with Order No. 1PP9 063-2LA12-Z A11+K50 (weight 4.37 kg).

<sup>4)</sup> Only for replacement purposes.

### Overview (continued)

#### *Taper pins acc. to DIN 258 with threaded ends and constant taper lengths*

Taper pins are used for components that are repeatedly removed. The drilled hole is ground conical using a conical reamer until the pin can be pushed in by hand until the cone shoulder lies 3 to 4 mm above the rim of the hole.

It can then be driven in using a hammer until it is correctly seated. The pin is removed from the drilled hole by screwing on the nut and tightening it.

Standardised taper pins are available from general engineering suppliers.

Available from:  
Otto Roth GmbH & Co. KG  
Rutesheimer Straße 22  
70499 Stuttgart, Germany  
Tel. +49 (0)711-13 88-0  
Fax +49 (0)711-13 88-233

<http://www.ottoroth.de>  
e-mail: [info@ottoroth.de](mailto:info@ottoroth.de)

#### *Couplings*

The motor from Siemens is connected to the machine or gear unit through a coupling. Flender is an important coupling manufacturer with a wide range of products. For standard applications, Siemens recommends that elastic couplings of Flender types N-Eupex and Rupex or torsionally rigid couplings of types Arpex and Zapex are used. For special applications, Fludex and Elpex couplings are recommended.

Source of supply:  
Siemens contact partner – ordering from Catalog  
Siemens MD 10.1 "FLENDER Standard Couplings"

or

A. Friedr. Flender AG  
Kupplungswerk Mussum  
Industriepark Bocholt  
Schlavenhorst 100  
46395 Bocholt, Germany  
Tel. +49 (0)2871-92 2185  
Fax +49 (0)2871-92 2579

<http://www.flender.com>  
e-mail: [couplings@flender.com](mailto:couplings@flender.com)

### More information

#### *Spare motors and repair parts*

- Supply commitment for spare motors and repair parts following delivery of the motor
  - For up to 5 years, in the event of total motor failure, Siemens will supply a comparable motor with regard to the mounting dimensions and functions (the type series may vary).
  - Repair parts will be supplied for up to 5 years.
  - For up to 10 years, Siemens will provide information and will, if necessary, supply documentation for repair parts.
- When repair parts are ordered, the following details must be provided:
  - Designation and part number
  - Order No. and factory number of the motor

Example for ordering a fan cowl 1LA7,  
frame size 160 M, 4-pole:

**Fan cowl No. 7.40,  
1LA7 163-4AA60, factory number J783298901018**

#### *Mounting of encoder*

In the case of mounting by the customer.

#### Options H79, H80

Baumer Hübner GmbH  
Planufer 92b  
10967 Berlin, Germany  
Tel. +49 (0)30-690 03-0  
Fax +49 (0)30-690 03-104

<http://www.baumerhuebner.com>  
e-mail: [info@baumerhuebner.com](mailto:info@baumerhuebner.com)

#### Options H78

Leine & Linde (Deutschland) GmbH  
Bahnhofstraße 36  
73430 Aalen, Germany  
Tel. +49 (0)7361-78 093-0  
Fax +49 (0)7361-78 093-11

<http://www.leinelinde.com>  
e-mail: [info@leinelinde.se](mailto:info@leinelinde.se)

- For bearing types, see the "Introduction".
- Repair parts for 1MJ6, 1MJ7, 1MJ8, 1MJ1, 1ME8, 1ML8, 1LG8 motors and smoke-extraction motors are available on request.
- For standard components, a supply commitment does not apply.
- Support – Hotline  
In Germany  
Tel.: 01 80/5 05 04 48

National telephone numbers can be found on the Internet page:  
<http://www.siemens.com/automation/service&support>

# IEC Squirrel-Cage Motors

## Standard motors frame size 315L and above

### Dimensions

#### Overview

##### Overall dimensions

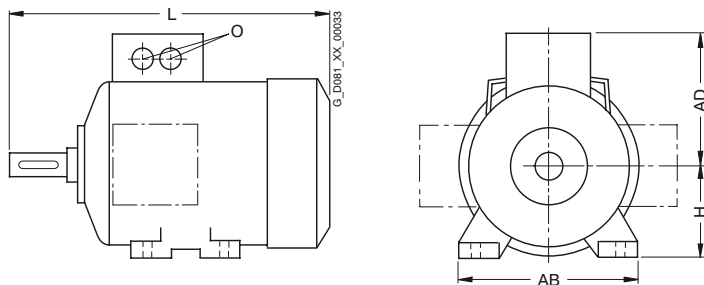

Frame size	Type	Number of poles	Dimensions							
			L	AD	H	AB	O			
56 M	1LA7		169	101	56	110	1 x M16 x 1.5			
	1LA9 050		169	101	56	110	1 x M25 x 1.5			
	1LA9 053		195	101	56	110	1 x M16 x 1.5 1 x M25 x 1.5			
63 M	1LA7		202.5	101	63	120	1 x M16 x 1.5			
	1LA9 063		202.5	101	63	120	1 x M25 x 1.5			
	1LA9 061		228.5	101	63	120	1 x M16 x 1.5 1 x M25 x 1.5			
71 M	1LA7		240	111	71	132	1 x M16 x 1.5			
	1LA9		240	111	71	132	1 x M16 x 1.5 1 x M25 x 1.5			
	1LP7		207	111	71	132	1 x M16 x 1.5 1 x M25 x 1.5			
80 M	1LA7		273.5	120	80	150	1 x M16 x 1.5			
	1LA9 080		273.5	120	80	150	1 x M16 x 1.5			
	1LA9 083		308.5	120	80	150	1 x M25 x 1.5			
	1LP7		237	120	80	150	1 x M16 x 1.5 1 x M25 x 1.5			
	1LA7		331	128	90	165	1 x M16 x 1.5			
90 S/ 90 L	1LA9		331	128	90	165	1 x M16 x 1.5 1 x M25 x 1.5			
	1LA9 096-6K.		376	128	90	165	1 x M16 x 1.5 1 x M25 x 1.5			
	1LA9 096-2..		358	128	90	165	1 x M16 x 1.5 1 x M25 x 1.5			
	1LA9 096-4..		358	128	90	165	1 x M16 x 1.5 1 x M25 x 1.5			
	1LP7		286	128	90	165	1 x M16 x 1.5 1 x M25 x 1.5			
	100 L			372	164	100	196	2 x M32 x 1.5		
	1LA7			372	135	100	196	2 x M32 x 1.5		
	1LA9			407	135	100	196	2 x M32 x 1.5		
	1LA9 107-4KA.			442	135	100	196	2 x M32 x 1.5		
1LP7	331	135		100	196	2 x M32 x 1.5				
112 M	1LA6		393	178	112	226	2 x M32 x 1.5			
	1LA7		393	148	112	226	2 x M32 x 1.5			
	1LA9		431	148	112	226	2 x M32 x 1.5			
	1LP7		349	148	112	226	2 x M32 x 1.5			
	132 S/ 132 M			453	194	132	256	2 x M32 x 1.5		
1LA7	452.5	167		132	256	2 x M32 x 1.5				
1LA9	452.5	167		132	256	2 x M32 x 1.5				
1LA9 131	490.5	167		132	256	2 x M32 x 1.5				
1LA9 133	490.5	167		132	256	2 x M32 x 1.5				
1LA9 134	490.5	167		132	256	2 x M32 x 1.5				
1LP7	397	167		132	256	2 x M32 x 1.5				
160 M/ 160 L	1LA6		588	226	160	300	2 x M40 x 1.5			
	1LA7		588	197	160	300	2 x M40 x 1.5			
	1LA9		588	197	160	300	2 x M40 x 1.5			
	1LA9 166		628	197	160	300	2 x M40 x 1.5			
	1LP7		529	197	160	300	2 x M40 x 1.5			
	180 M/ 180 L		1LA5		712	258	180	339	2 x M40 x 1.5	
			1LA9		712	258	180	339	2 x M40 x 1.5	
			1LG4		669	262	180	339	2 x M40 x 1.5	
			1LG4 188		720	262	180	339	2 x M40 x 1.5	
			1LG6 183		2	720	262	180	339	2 x M40 x 1.5
			1LG6 183		4	669	262	180	339	2 x M40 x 1.5
			1LG6 186		4, 6, 8	720	262	180	339	2 x M40 x 1.5
			1LP4 183		2, 4	562	262	180	339	2 x M40 x 1.5
			1LP4 186		4, 6, 8	562	262	180	339	2 x M40 x 1.5
			1LP5		611	258	180	339	2 x M40 x 1.5	
	200 L		1LA5		769.5	305	200	388	2 x M50 x 1.5	
			1LA9		768.5	305	200	388	2 x M50 x 1.5	
			1LG4		720	300	200	378	2 x M50 x 1.5	
			1LG4 208		2, 6	777	300	200	378	2 x M50 x 1.5
			1LG6 206		720	300	200	378	2 x M50 x 1.5	
1LG6 207		2, 6	777		300	200	378	2 x M50 x 1.5		
1LG6 207		4, 8	720		300	200	378	2 x M50 x 1.5		
1LP4 206		2, 6	617		300	200	378	2 x M50 x 1.5		
1LP4 207		2, 4, 6, 8	617		300	200	378	2 x M50 x 1.5		
1LP5		675	305		200	388	2 x M50 x 1.5			
225 S/ 225 M	1LA5		806	305	225	426	2 x M50 x 1.5			
	1LA5		2	776	305	225	426	2 x M50 x 1.5		
	1LG4		789	325	225	436	2 x M50 x 1.5			
	1LG4 223		2	759	325	225	436	2 x M50 x 1.5		
	1LG4 228		2	819	325	225	436	2 x M50 x 1.5		
	1LG4 228		4, 6, 8	849	325	225	436	2 x M50 x 1.5		
	1LG6 220		4, 8	789	325	225	436	2 x M50 x 1.5		
	1LG6 223		2	819	325	225	436	2 x M50 x 1.5		
	1LG6 223		4, 6, 8	849	325	225	436	2 x M50 x 1.5		
	1LG6 228		2	869	325	225	436	2 x M50 x 1.5		
	1LG6 228		4, 6	899	325	225	436	2 x M50 x 1.5		
	1LP4 220		4, 8	670	325	225	436	2 x M50 x 1.5		
	1LP4 223		2	640	325	225	436	2 x M50 x 1.5		
1LP4 223	4, 6, 8	670	325	225	436	2 x M50 x 1.5				
250 M	1LG4		887	392	250	490	2 x M63 x 1.5			
	1LG4 258		4	957	392	250	490	2 x M63 x 1.5		
	1LG6 253		2, 6, 8	887	392	250	490	2 x M63 x 1.5		
	1LG6 253		4	957	392	250	490	2 x M63 x 1.5		
	1LG6 258		2, 4, 6	957	392	250	490	2 x M63 x 1.5		
	1LP4 253		2	764	392	250	490	2 x M63 x 1.5		
	1LP4 253		4, 6, 8	764	392	250	490	2 x M63 x 1.5		

# IEC Squirrel-Cage Motors

## Standard motors frame size 315L and above

### Dimensions

#### Overview (continued)

Frame size	Type	Number of poles	Dimensions				
			L	AD	H	AB	O
280 S/	1LG4		960	432	280	540	2 x M63 x 1.5
280 M	1LG4 288	2, 4	1070	432	280	540	2 x M63 x 1.5
	1LG6 280	2, 4, 6, 8	960	432	280	540	2 x M63 x 1.5
	1LG6 283	2, 4	1070	432	280	540	2 x M63 x 1.5
	1LG6 283	6, 8	960	432	280	540	2 x M63 x 1.5
	1LG6 288	2, 4, 6	1070	432	280	540	2 x M63 x 1.5
	1LP4 280	2, 4, 6, 8	830	432	280	540	2 x M63 x 1.5
	1LP4 283	2, 4, 6, 8	830	432	280	540	2 x M63 x 1.5
315 S/	1LG4		1072	500	315	610	2 x M63 x 1.5
315 M/	1LG4 310	4, 6, 8	1102	500	315	610	2 x M63 x 1.5
315 L	1LG4 313	4, 6, 8	1102	500	315	610	2 x M63 x 1.5
	1LG4 316	2	1232	500	315	610	2 x M63 x 1.5
	1LG4 316	4, 6, 8	1262	500	315	610	2 x M63 x 1.5
	1LG4 317	2	1232	500	315	610	2 x M63 x 1.5
	1LG4 317	4, 6, 8	1262	500	315	610	2 x M63 x 1.5
	1LG4 318	8	1262	500	315	610	2 x M63 x 1.5
	1LG4 318	6	1402	500	315	610	2 x M63 x 1.5

Frame size	Type	Number of poles	Dimensions				
			L	AD	H	AB	O
315 S/	1LG6 310	2	1072	500	315	610	2 x M63 x 1.5
315 M/	1LG6 310	4, 6, 8	1102	500	315	610	2 x M63 x 1.5
315 L	1LG6 313	2	1232	500	315	610	2 x M63 x 1.5
	1LG6 313	4, 6	1262	500	315	610	2 x M63 x 1.5
	1LG6 313	8	1102	500	315	610	2 x M63 x 1.5
	1LG6 316	2	1232	500	315	610	2 x M63 x 1.5
	1LG6 316	4, 6, 8	1262	500	315	610	2 x M63 x 1.5
	1LG6 317	8	1262	500	315	610	2 x M63 x 1.5
	1LG6 317	2	1372	500	315	610	2 x M63 x 1.5
	1LG6 317	4, 6	1402	500	315	610	2 x M63 x 1.5
	1LG6 318	2	1372	651	315	610	2 x M63 x 1.5
	1LG6 318	4	1402	651	315	610	2 x M63 x 1.5
	1LG6 318	6, 8	1402	500	315	610	2 x M63 x 1.5
	1LP4 310	2	925	500	315	610	2 x M63 x 1.5
	1LP4 310	4, 6, 8	955	500	315	610	2 x M63 x 1.5
	1LP4 313	2	925	500	315	610	2 x M63 x 1.5
	1LP4 313	4, 6, 8	955	500	315	610	2 x M63 x 1.5
	1LP4 316	2	1085	500	315	610	2 x M63 x 1.5
	1LP4 316	4, 6, 8	1115	500	315	610	2 x M63 x 1.5
	1LP4 317	2	1085	500	315	610	2 x M63 x 1.5
	1LP4 317	4, 6, 8	1115	500	315	610	2 x M63 x 1.5

#### Notes on the dimensions

■ Dimension drawings according to DIN EN 50347 and IEC 60072.

#### ■ Fits

The shaft extensions specified in the dimension tables (DIN 748) and centering spigot diameters (DIN EN 50347) are machined with the following fits:

Dimension designation	ISO fit	DIN ISO 286-2
D, DA	to 30	j6
	over 31 to 50	k6
	over 50	m6
N	to 250	j6
	over 250	h6
F, FA		h9
K		H17
S	flange (FF)	H17

The drilled holes of couplings and belt pulleys should have an ISO fit of at least H7.

#### ■ Dimension tolerances

For the following dimensions, the admissible deviations are given below:

Dimension designation	Dimension	Permitted deviation
H	to 250	- 0.5
	over 250	- 1.0
E, EA		- 0.5

Keyways and feather keyways (dimensions GA, GC, F and FA) are made in compliance with DIN 6885 Part 1.

■ All dimensions are specified in mm.

#### More information

##### Dimension sheet generator

(part of the SD configurator)

A dimension drawing can be created in the SD configurator for every configurable motor. A dimension drawing can be requested for every other motor.

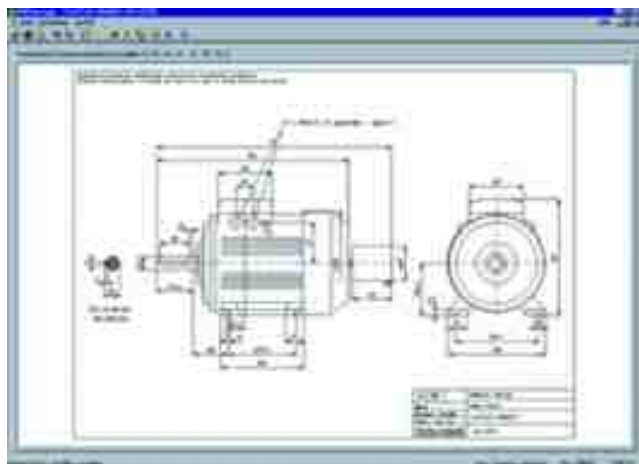

When a complete Order No. is entered with or without order codes, a dimension drawing can be called up under the "Documentation" tab.

These dimension drawings can be presented in different views and sections and printed.

The corresponding dimension sheets can be exported, saved and processed further in DXF format (interchange/import format for CAD systems) or as bitmap graphics.

The SD configurator has been integrated into the electronic Catalog CA 01 as a selection aid (for further information, catalog part 11 "Appendix", "SD configurator selection tool").

The interactive Catalog CA 01 can be ordered from your local Siemens sales representative or on the Internet at

<http://www.siemens.com/automation/CA01>

At this address, you will also find links to Tips & Tricks and to downloads for function or content updates.

Order number for CA 01 10/2008, English international:  
DVD: E86060-D4001-A510-C7-7600

# IEC Squirrel-Cage Motors

## Standard motors up to frame size 315 L

### Dimensions

#### Dimensional drawings

Aluminum series 1LA7 and 1LA5, frame sizes 56 M to 225 M

#### Type of construction IM B3

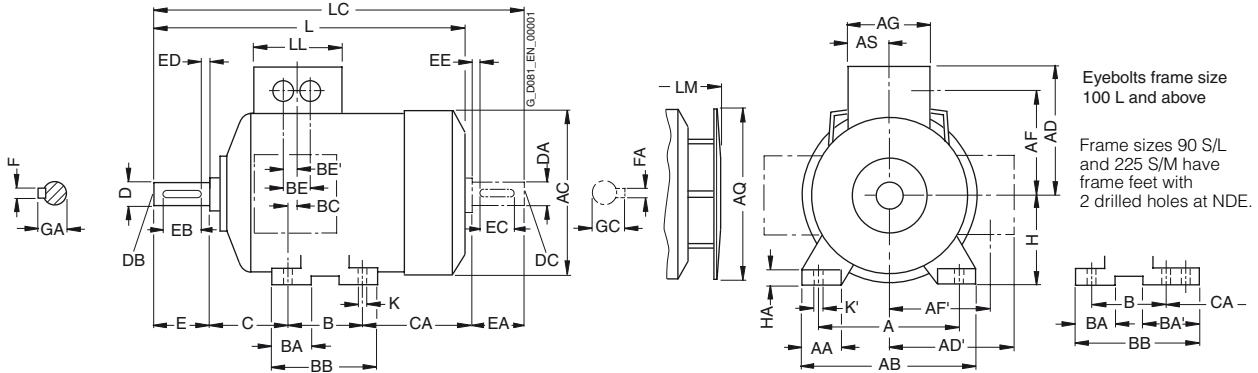

#### Types of construction IM B5 and IM V1

For flange dimensions, see Page 2/140 (Z = the number of retaining holes)

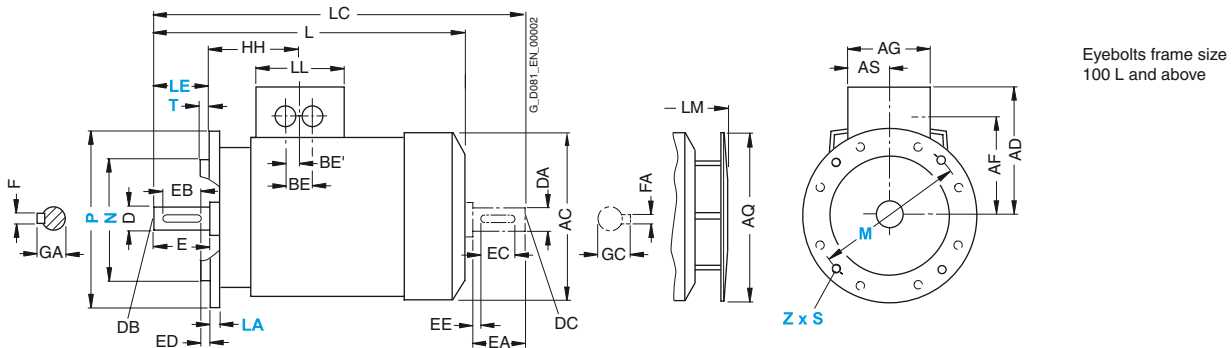

For motor		Dimension designation acc. to IEC																						
Frame size	Type	Number of poles	A	AA	AB	AC <sup>1)</sup>	AD <sup>2)</sup>	AD' <sup>2)</sup>	AF <sup>2)</sup>	AF'	AG <sup>2)</sup>	AQ	AS	B*	BA	BA'	BB	BC	BE <sup>2)</sup>	BE' <sup>2)</sup>	C	CA*	H	HA
56 M <sup>3)</sup>	1LA7 050 1LA7 053	2, 4	90	25	110	116	101	101	78	78	75	-	37.5	71	28	-	87	34	32	18	36	53	56	6
63 M	1LA7 060 1LA7 063	2, 4, 6	100	27	120	124	101	101	78	78	75	124	37.5	80	28	-	96	30	32	18	40	66	63	7
71 M	1LA7 070 1LA7 073	2, 4, 6, 8	112	27	132	145	111	111	88	88	75	124	37.5	90	27	-	106	18	32	18	45	83	71	7
80 M	1LA7 080 1LA7 083	2, 4, 6, 8	125	30.5	150	163	120	120	97	97	75	124	37.5	100	32	-	118	14	32	18	50	94	80	8
90 S 90 L	1LA7 090 1LA7 096	2, 4, 6, 8	140	30.5	165	180	128	128	105	105	75	170	37.5	100	33	54	143	23	32	18	56	143	90	10
100 L	1LA7 106 1LA7 107	2, 4, 6, 8 4, 8	160	42	196	203	135	163	78	123	120	170	60	140	47	-	176	39	42	21	63	125	100	12
112 M	1LA7 113	2, 4, 6, 8	190	46	226	227	148	176	91	136	120	170	60	140	47	-	176	32	42	21	70	141	112	12
132 S	1LA7 130 1LA7 131	2, 4, 6, 8 2	216	53	256	267	167	194	107	154	140	250	70	140	49	-	180	39	42	21	89	162.5	132	15
132 M	1LA7 133 1LA7 134	4, 6, 8 6	216	53	256	267	167	194	107	154	140	250	70	178	49	-	218	39	42	21	89	124.5	132	15
160 M	1LA7 163 1LA7 164	2, 4, 6, 8 2, 8	254	60	300	320	197	226	127	183	165	250	82.5	210	57	-	256	52.5	54	27	108	183	160	18
160 L	1LA7 166	2, 4, 6, 8	254	60	300	320	197	226	127	183	165	250	82.5	254	57	-	300	52.5	54	27	108	139	160	18
180 M	1LA5 183	2, 4	279	69.5	339	363	258	258	216	216	152	340	71	241	50	-	287	38	54	27	121	259	180	18
180 L	1LA5 186	4, 6, 8	279	69.5	339	363	258	258	216	216	152	340	71	279	50	-	325	38	54	27	121	221	180	18
200 L	1LA5 206 1LA5 207	2, 6 2, 4, 6, 8	318	83	388	402	305	305	252	252	260	340	96	305	58.5	-	355	45	85	42.5	133	239	200	24
225 S	1LA5 220	4, 8	356	103	426	402	305	305	252	252	260	340	96	286	58	83	361	36	85	42.5	149	248.5	225	24
225 M	1LA5 223	2 4, 6, 8	356	103	426	402	305	305	252	252	260	340	96	311	58	83	361	36	85	42.5	149	223.5	225	24

■ For 1LA7 and 1LA5 standard motors in pole-changing version (6 or 9 terminals), the dimensions of the basic version apply.

\* This dimension is assigned in DIN EN 50347 to the frame size listed.

1) Measured across the bolt heads.

2) The values increase if the connection box is rotated or if a brake is mounted. Further information is provided by the dimension sheet generator in SD configurator.

3) The motors of frame size 56 M are not ventilated.

# IEC Squirrel-Cage Motors

## Standard motors up to frame size 315 L

### Dimensions

#### Dimensional drawings

##### Aluminum series 1LA7 and 1LA5, frame sizes 56 M to 225 M

##### Type of construction IM B35

For flange dimensions, see Page 2/140 (Z = the number of retaining holes)

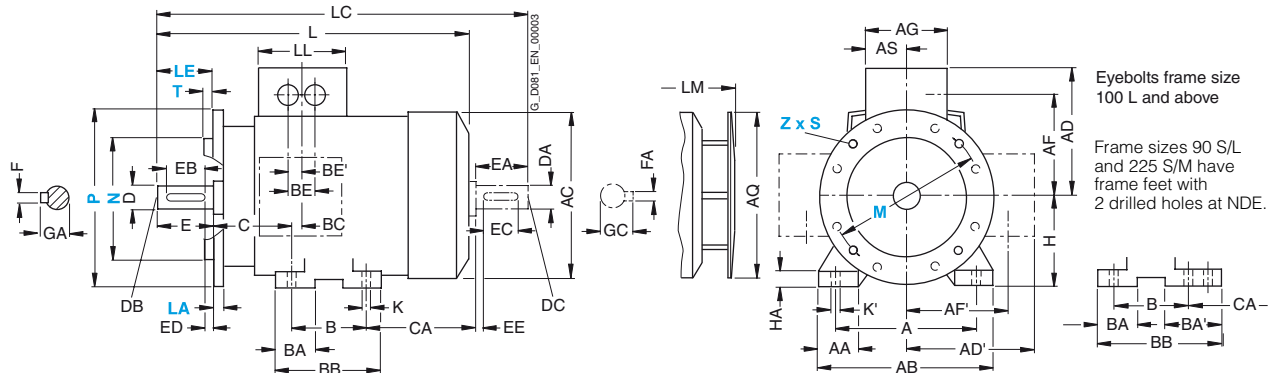

##### Type of construction IM B14

Type of construction IM B14 not possible for 1LA5 motors, frame sizes 180 M to 225 M

For flange dimensions, see Page 2/140 (Z = the number of retaining holes)

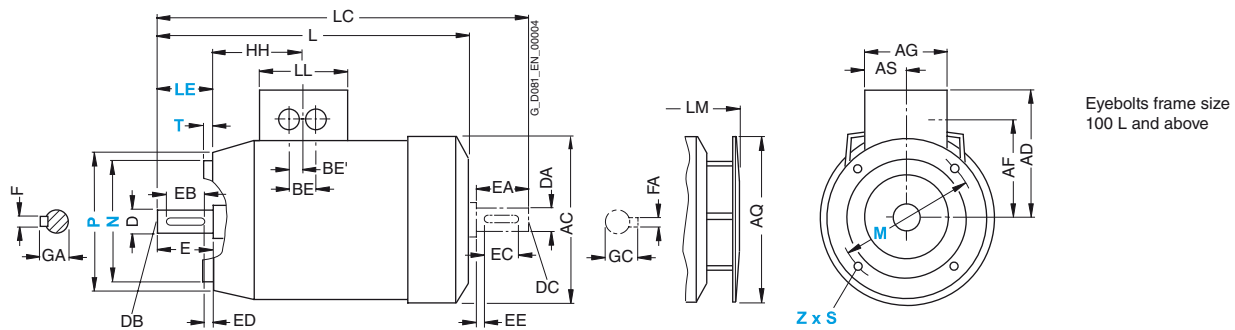

For motor Frame size	Type	Number of poles	Dimension designation acc. to IEC							DE shaft extension					NDE shaft extension								
			HH	K	K'	L	LC	LL	LM	D	DB	E	EB	ED	F	GA	DA	DC	EA	EC	EE	FA	GC
56 M <sup>1)</sup>	1LA7 050 1LA7 053	2, 4	69.5	5.8	9	169	200	75	-	9	M3	20	14	3	3	10.2	9	M3	20	14	3	3	10.2
63 M	1LA7 060 1LA7 063	2, 4, 6	69.5	7	10	202.5 <sup>3)</sup>	232 <sup>3)</sup>	75	231.5 <sup>3)</sup>	11	M4	23	16	3.5	4	12.5	11	M4	23	16	3.5	4	12.5
71 M	1LA7 070 1LA7 073	2, 4, 6, 8	63.5	7	10	240	278	75	268	14	M5	30	22	4	5	16	14	M5	30	22	4	5	16
80 M	1LA7 080 1LA7 083	2, 4, 6, 8	63.5	9.5	13.5	273.5	324 364	75	299.5	19	M6	40	32	4	6	21.5	19	M6	40	32	4	6	21.5
90 S 90 L	1LA7 090 1LA7 096	2, 4, 6, 8	79	10	14	331	389	75	382.5	24	M8	50	40	5	8	27	19	M6	40	32	4	6	21.5
100 L	1LA7 106 1LA7 107	2, 4, 6, 8 4, 8	102	12	16	372	438	120	423.5	28	M10	60	50	5	8	31	24	M8	50	40	5	8	27
112 M	1LA7 113	2, 4, 6, 8	102	12	16	393	461	120	444.5	28	M10	60	50	5	8	31	24	M8	50	40	5	8	27
132 S	1LA7 130 1LA7 131	2, 4, 6, 8 2	128	12	16	452.5 <sup>2)</sup>	551.5	140	505 <sup>2)</sup>	38	M12	80	70	5	10	41	38	M12	80	70	5	10	41
132 M	1LA7 133 1LA7 134	4, 6, 8 6	128	12	16	452.5 <sup>2)</sup>	551.5	140	505 <sup>2)</sup>	38	M12	80	70	5	10	41	38	M12	80	70	5	10	41
160 M	1LA7 163 1LA7 164 2, 8	2, 4, 6, 8	160.5	15	19	588	721	165	640.5	42	M16	110	90	10	12	45	42	M16	110	90	10	12	45
160 L	1LA7 166	2, 4, 6, 8	160.5	15	19	588	721	165	640.5	42	M16	110	90	10	12	45	42	M16	110	90	10	12	45
180 M	1LA5 183	2, 4	159	15	19	712	841	132	793.5	48	M16	110	100	5	14	51.5	48	M16	110	100	5	14	51.5
180 L	1LA5 186	4, 6, 8	159	15	19	712	841	132	793.5	48	M16	110	100	5	14	51.5	48	M16	110	100	5	14	51.5
200 L	1LA5 206 1LA5 207	2, 6 2, 4, 6, 8	178	19	25	769.5	897	192	850	55	M20	110	100	5	16	59	55	M20	110	100	5	16	59
225 S	1LA5 220	4, 8	184.5	19	25	806	933.5	192	887.5	60	M20	140	125	7.5	18	64	55	M20	110	100	5	16	59
225 M	1LA5 223	2 4, 6, 8	184.5	19	25	776 806	903.5 933.5	192	857.5 887.5	55 60	M20	110 140	100 125	5 7.5	16 18	59 64	55	M20	110	100	5	16	59

<sup>1)</sup> The motors of frame size 56 M are not ventilated.

<sup>2)</sup> In a low-noise version, the dimension L is 8 mm greater and the dimension LM is 11.5 mm greater.

<sup>3)</sup> For 1LA7 063 with type of construction code 1 (B5, IM V1 without protective cover, IM V3) the dimensions L, LC and LM are 26 mm longer.

# IEC Squirrel-Cage Motors

## Standard motors up to frame size 315 L

### Dimensions

#### Dimensional drawings

Aluminum series 1LA9, frame sizes 56 M to 200 L

#### Type of construction IM B3

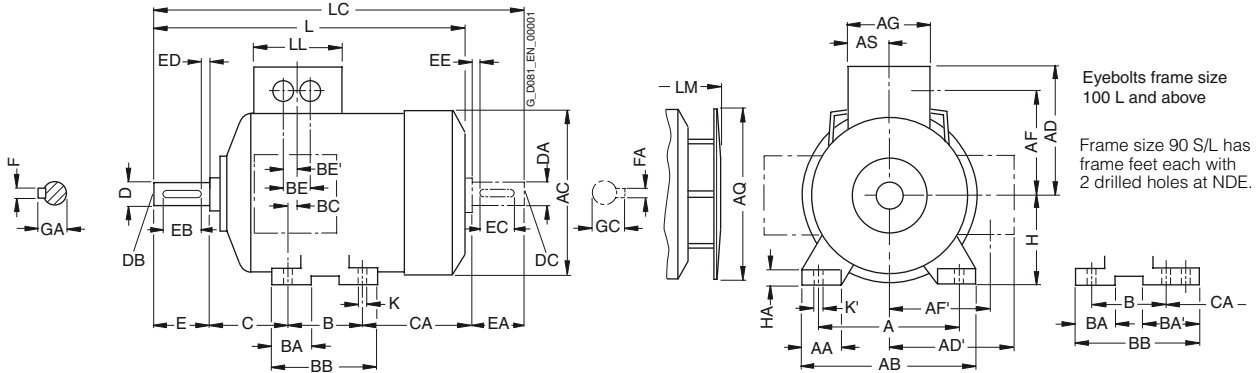

#### Types of construction IM B5 and IM V1

For flange dimensions, see Page 2/140 (Z = the number of retaining holes)

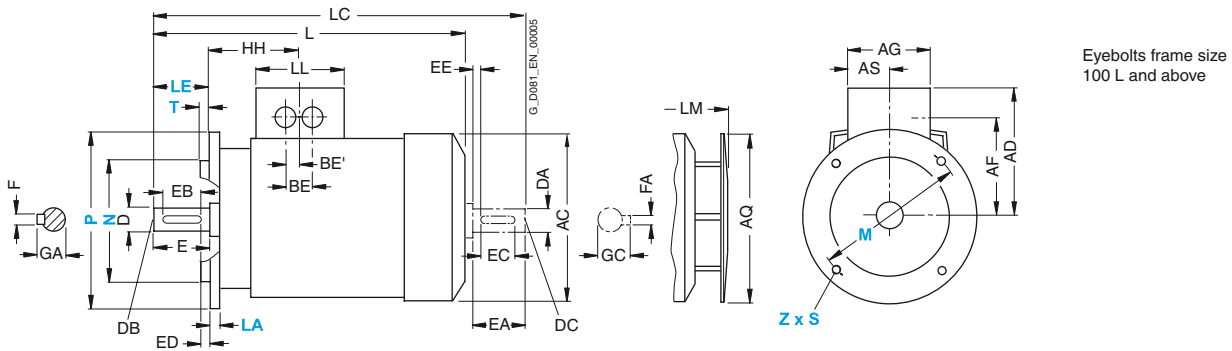

For motor		Dimension designation acc. to IEC																						
Frame size	Type	Number of poles	A	AA	AB	AC <sup>1)</sup>	AD	AD'	AF	AF'	AG	AQ	AS	B*	BA	BA'	BB	BC	BE	BE'	C	CA*	H	HA
56 M <sup>2)</sup>	1LA9 050 1LA9 053	2, 4	90	25	110	116	101	101	78	78	75	-	37.5	71	28	-	87	34	32	18	36	53	56	6
63 M	1LA9 060 1LA9 063	2, 4	100	27	120	124	101	101	78	78	75	124	37.5	80	28	-	96	30	32	18	40	66 92	63	7
71 M	1LA9 070 1LA9 073	2, 4	112	30.5	132	145	111	111	88	88	75	124	37.5	90	27	-	106	18	32	18	45	83	71	7
80 M	1LA9 080 1LA9 083	2, 4	125	30.5	150	163	120	120	97	97	75	124	37.5	100	32	-	118	14	32	18	50	94 134	80	8
90 S 90 L	1LA9 090 1LA9 096	2, 4, 6	140	30.5	165	180	128	128	105	105	75	170	37.5	100 125	33	54	143	23	32	18	56	143 118	90	10
100 L	1LA9 106 1LA9 107	2, 4, 6	160	42	196	203	135	163	78	123	120	170	60	140	47	-	176	39	42	21	63	160 195 <sup>3)</sup>	100	12
112 M	1LA9 113	2, 4, 6	190	46	226	227	148	176	91	136	120	170	60	140	47	-	176	32	42	21	70	179	112	12
132 S	1LA9 130	2, 4	216	53	256	267	167	194	107	154	140	250	70	140	49	-	180	39	42	21	89	162.5 200.5	132	15
132 M	1LA9 133 1LA9 133 1LA9 134	6 4 6	216	53	256	267	167	194	107	154	140	250	70	178	49	-	218	39	42	21	89	124.5 162.5	132	15
160 M	1LA9 163 1LA9 164	2, 4, 6 2	254	60	300	320	197	226	127	183	165	250	82.5	210	57	-	256	52.5	54	27	108	183	160	18
160 L	1LA9 166	2, 4, 6	254	60	300	320	197	226	127	183	165	250	82.5	254	57	-	300	52.5	54	27	108	179	160	18
180 M	1LA9 183	2, 4	279	69.5	339	363	258	258	216	216	152	340	71	241	50	-	287	38	54	27	121	259	180	18
180 L	1LA9 186	4, 6	279	69.5	339	363	258	258	216	216	152	340	71	279	50	-	325	38	54	27	121	221	180	18
200 L	1LA9 206 1LA9 207	2, 6 2, 4, 6	318	83	388	402	305	305	252	252	260	340	96	305	58.5	-	355	45	85	42.5	133	239	200	24

\* This dimension is assigned in DIN EN 50347 to the frame size listed.

<sup>1)</sup> Measured across the bolt heads.

<sup>2)</sup> The motors of frame size 56 M are not ventilated. Frame size 56 M is not available in IM B35.

<sup>3)</sup> For 1LA9 107-4KA.



# IEC Squirrel-Cage Motors

## Standard motors up to frame size 315 L

### Dimensions

#### Dimensional drawings

##### Aluminum series 1LA9, frame sizes 56 M to 200 L

##### Type of construction IM B35

For flange dimensions, see Page 2/140 (Z = the number of retaining holes)

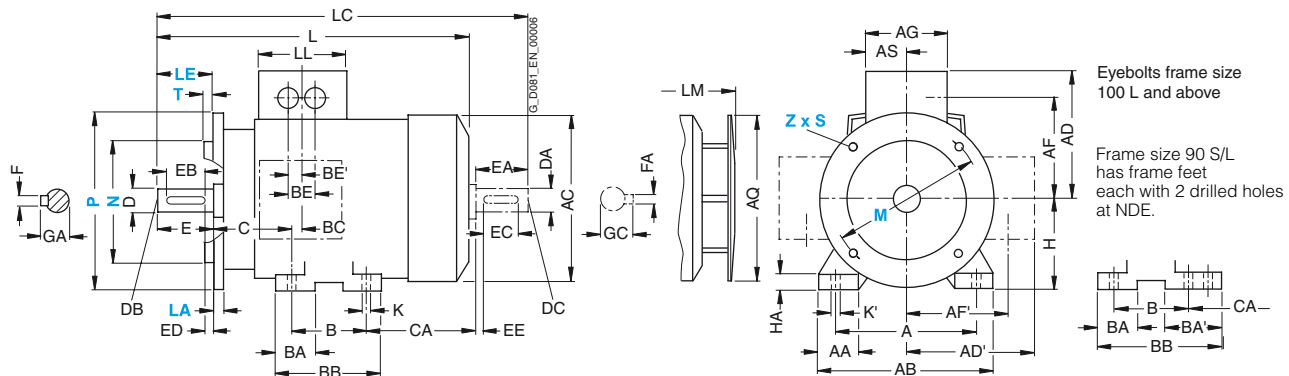

Eyebolts frame size  
100 L and above

Frame size 90 S/L  
has frame feet  
each with 2 drilled holes  
at NDE.

##### Type of construction IM B14

Type of construction IM B14 not possible for 1LA9 motors, frame sizes 180 M to 200 L

For flange dimensions, see Page 2/140 (Z = the number of retaining holes)

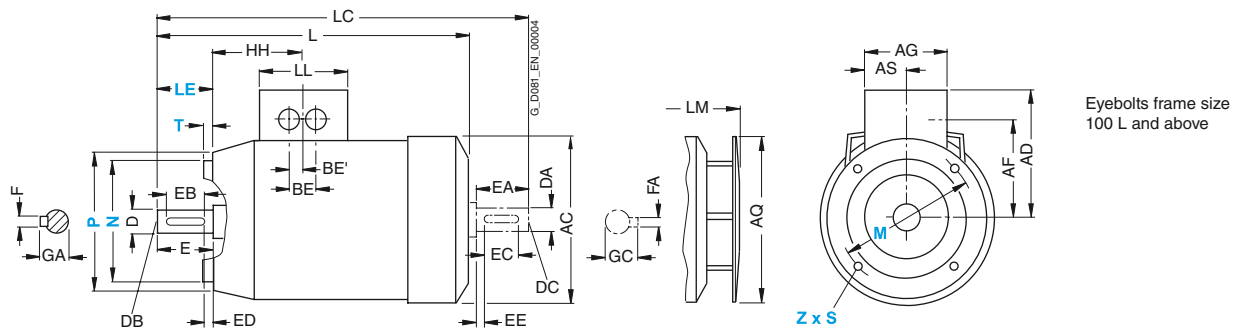

Eyebolts frame size  
100 L and above

For motor		Dimension designation acc. to IEC								DE shaft extension					NDE shaft extension								
Frame size	Type	Number of poles	HH	K	K'	L	LC	LL	LM	D	DB	E	EB	ED	F	GA	DA	DC	EA	EC	EE	FA	GC
56 M <sup>1)</sup>	1LA9 050 1LA9 053	2, 4	69.5	5.8	9	169 <sup>2)</sup> 195	200 <sup>2)</sup> 226	75	–	9	M3	20	14	3	3	10.2	9	M3	20	14	3	3	10.2
63 M	1LA9 060 1LA9 063	2, 4	69.5	7	10	202.5 <sup>3)</sup> 228.5	232 <sup>3)</sup> 258	75	231.5 257.5	11	M4	23	16	3.5	4	12.5	11	M4	23	16	3.5	4	12.5
71 M	1LA9 070 1LA9 073	2, 4	63.5	7	10	240	278	75	268	14	M5	30	22	4	5	16	14	M5	30	22	4	5	16
80 M	1LA9 080 1LA9 083	2, 4	63.5	9.5	13.5	273.5 308.5	324 364	75	299.5 334.5	19	M6	40	32	4	6	21.5	19	M6	40	32	4	6	21.5
90 S 90 L	1LA9 090 1LA9 096	2, 4, 6	79	10	14	331 376 <sup>4)</sup> 358 <sup>5)</sup>	389 434 <sup>4)</sup> 414 <sup>5)</sup>	75	382.5 427.5 <sup>4)</sup> 409.5 <sup>5)</sup>	24	M8	50	40	5	8	27	19	M6	40	32	4	6	21.5
100 L	1LA9 106 1LA9 107	2, 4, 6	102	12	16	407 442 <sup>6)</sup>	473 508 <sup>6)</sup>	120	458.5 493 <sup>6)</sup>	28	M10	60	50	5	8	31	24	M8	50	40	5	8	27
112 M	1LA9 113	2, 4, 6	102	12	16	431	499	120	482.5	28	M10	60	50	5	8	31	24	M8	50	40	5	8	27
132 S	1LA9 130 1LA9 131	2, 4	128	12	16	452.5 490.5	551.5 589.5	140	505 543	38	M12	80	70	5	10	41	38	M12	80	70	5	10	41
132 M	1LA9 133 1LA9 133 1LA9 134	6 4 6	128	12	16	452.5 490.5	551.5 589.5	140	505 543	38	M12	80	70	5	10	41	38	M12	80	70	5	10	41
160 M	1LA9 163 1LA9 164	2, 4, 6 2	160.5	15	19	588	721	165	640.5	42	M16	110	90	10	12	45	42	M16	110	90	10	12	45
160 L	1LA9 166	2, 4, 6	160.5	15	19	628	761	165	680.5	42	M16	110	90	10	12	45	42	M16	110	90	10	12	45
180 M	1LA9 183	2, 4	159	15	19	712	841	132	793.5	48	M16	110	100	5	14	51.5	48	M16	110	100	5	14	51.5
180 L	1LA9 186	4, 6	159	15	19	712	841	132	793.5	48	M16	110	100	5	14	51.5	48	M16	110	100	5	14	51.5
200 L	1LA9 206 1LA9 207	2, 6 2, 4, 6	178	19	25	768.5	897	192	850	55	M20	110	100	5	16	59	55	M20	110	100	5	16	59

<sup>1)</sup> The motors of frame size 56 M are not ventilated. Frame size 56 M is not available in IM B35.

<sup>2)</sup> For 1LA9 frame size 56 M with type of construction code 1 (B5, IM V1 without protective cover, IM V3) the dimensions L and LC are 26 mm longer.

<sup>3)</sup> For 1LA9 060 with type of construction code 1 (B5, IM V1 without protective cover, IM V3) the dimensions L, LC and LM are 26 mm longer.

<sup>4)</sup> For 1LA9 096-6KA.

<sup>5)</sup> For 1LA9 096-2 and 1LA9 096-4.

<sup>6)</sup> For 1LA9 107-4KA.

# IEC Squirrel-Cage Motors

## Standard motors up to frame size 315 L

### Dimensions

#### Dimensional drawings

Cast-iron series 1LA6, frame sizes 100 L to 160 L

#### Type of construction IM B3

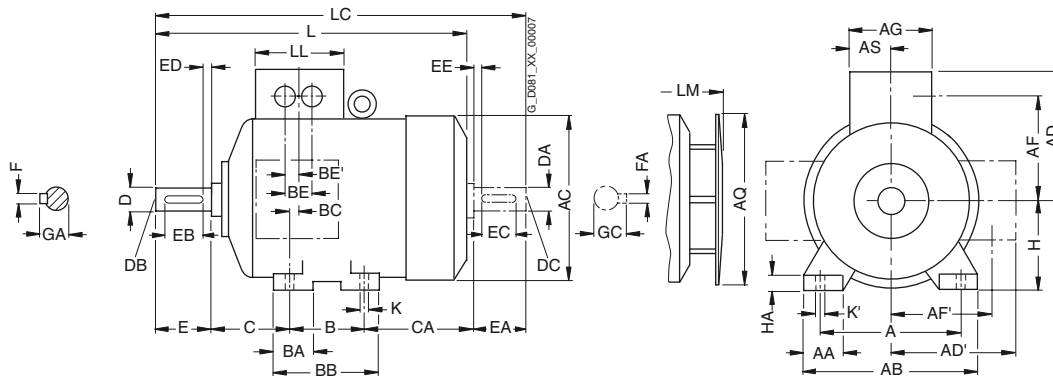

#### Types of construction IM B5 and IM V1

For flange dimensions, see Page 2/140 (Z = the number of retaining holes)

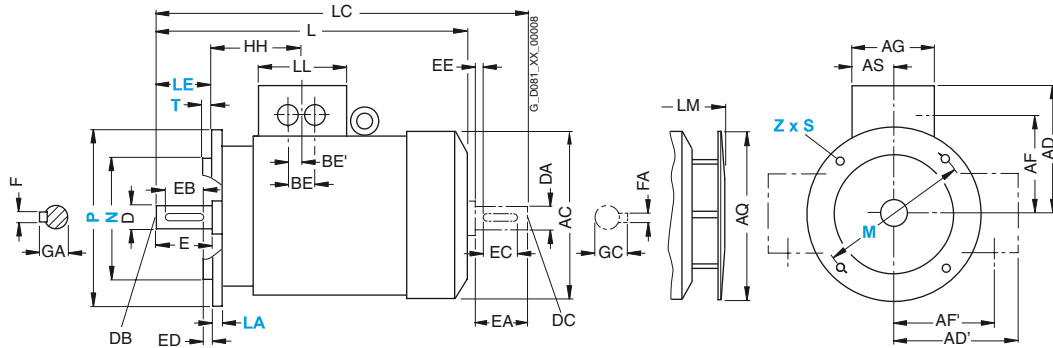

For motor		Dimension designation acc. to IEC																					
Frame size	Type	Number of poles	A	AA	AB	AC <sup>1)</sup>	AD	AD'	AF	AF'	AG	AQ	AS	B	BA	BB	BC	BE	BE'	C	CA	H	HA
100 L	1LA6 106	2, 4, 6, 8	160	40	196	201	164	164	124	124	121	170	60.5	140	46	180	42	44	22	63	125	100	12
	1LA6 107	4, 8																					
112 M	1LA6 113	2, 4, 6, 8	190	42.5	226	225.5	178	178	138	138	121	170	60.5	140	46	180	34	44	22	70	141	112	15
132 S	1LA6 130	2, 4, 6, 8	216	50	256	265	194	194	154	154	141	250	70.5	140	47	180	42	44	22	89	162.5	132	17
	1LA6 131	2																					
132 M	1LA6 133	4, 6, 8	216	50	256	265	194	194	154	154	141	250	70.5	178	49	218	42	44	22	89	124.5	132	17
	1LA6 134	6																					
160 M	1LA6 163	2, 4, 6, 8	254	60	300	320	226	226	183	183	166	250	83	210	63	256	52	54	27	108	183	160	18
	1LA6 164	2, 8																					
160 L	1LA6 166	2, 4, 6, 8	254	60	300	320	226	226	183	183	166	250	83	254	63	300	52	54	27	108	139	160	18

<sup>1)</sup> Measured across the bolt heads.

# IEC Squirrel-Cage Motors

## Standard motors up to frame size 315 L

### Dimensions

#### Dimensional drawings

Cast-iron series 1LA6, frame sizes 100 L to 160 L

#### Type of construction IM B35

For flange dimensions, see Page 2/140 (Z = the number of retaining holes)

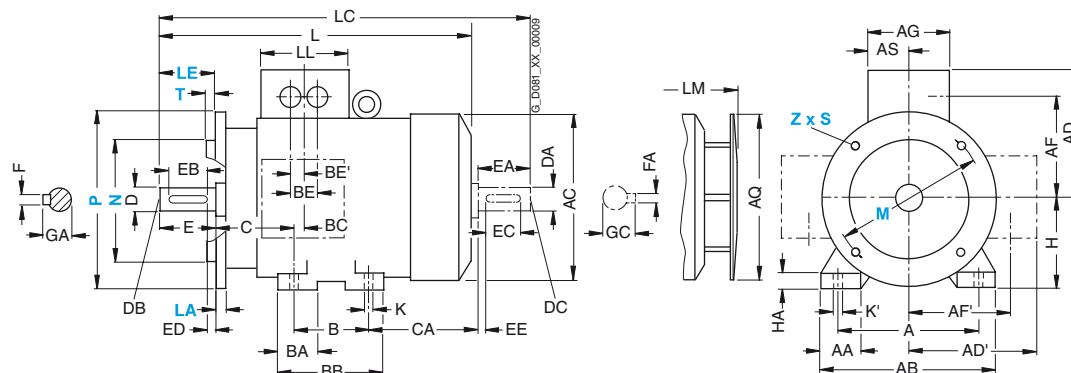

#### Types of construction IM B14

For flange dimensions, see Page 2/140 (Z = the number of retaining holes)

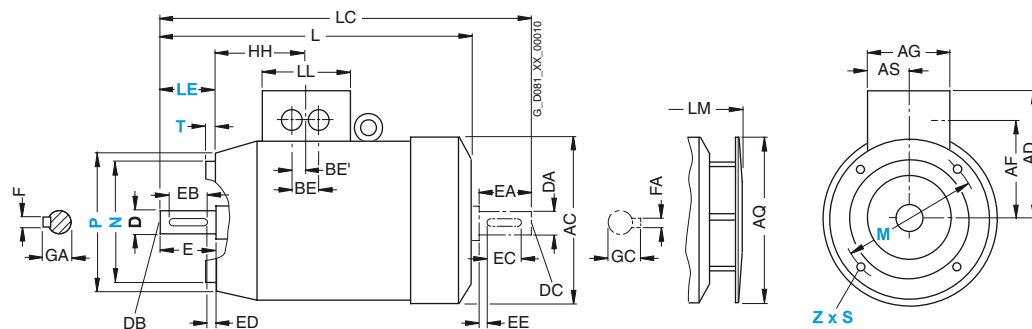

For motor		Dimension designation acc. to IEC										DE shaft extension				NDE shaft extension							
Frame size	Type	Number of poles	HH	K	K'	L	LC	LL	LM	D	DB	E	EB	ED	F	GA	DA	DC	EA	EC	EE	FA	GC
100 L	1LA6 106 1LA6 107	2, 4, 6, 8 4, 8	104.5	12	16	372	438	121	423.5	28	M10	60	50	5	8	31	24	M8	50	40	5	8	27
112 M	1LA6 113	2, 4, 6, 8	104.5	12	16	393	461	121	444.5	28	M10	60	50	5	8	31	24	M8	50	40	5	8	27
132 S	1LA6 130 1LA6 131	2, 4, 6, 8 2	130.5	12	16	453.5	551.5	141	506	38	M12	80	70	5	10	41	38	M12	80	70	5	10	41
132 M	1LA6 133 1LA6 134	4, 6, 8 6	130.5	12	16	453.5	551.5	141	506	38	M12	80	70	5	10	41	38	M12	80	70	5	10	41
160 M	1LA6 163 1LA6 164	2, 4, 6, 8 2, 8	160	14.5	18	588	721	166	640.5	42	M16	110	90	10	12	45	42	M16	110	90	10	12	45
160 L	1LA6 166	2, 4, 6, 8	160	14.5	18	588	721	166	640.5	42	M16	110	90	10	12	45	42	M16	110	90	10	12	45





# IEC Squirrel-Cage Motors

## Standard motors up to frame size 315 L

### Dimensions

#### Dimensional drawings

Cast-iron series 1LG6, frame sizes 180 M to 250 M

#### Type of construction IM B3

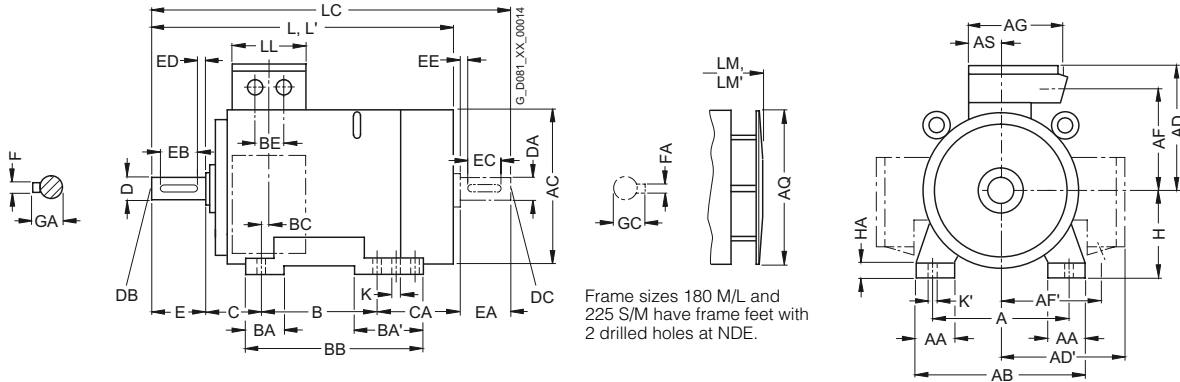

#### Types of construction IM B5 and IM V1

For flange dimensions, see Page 2/140 (Z = the number of retaining holes)

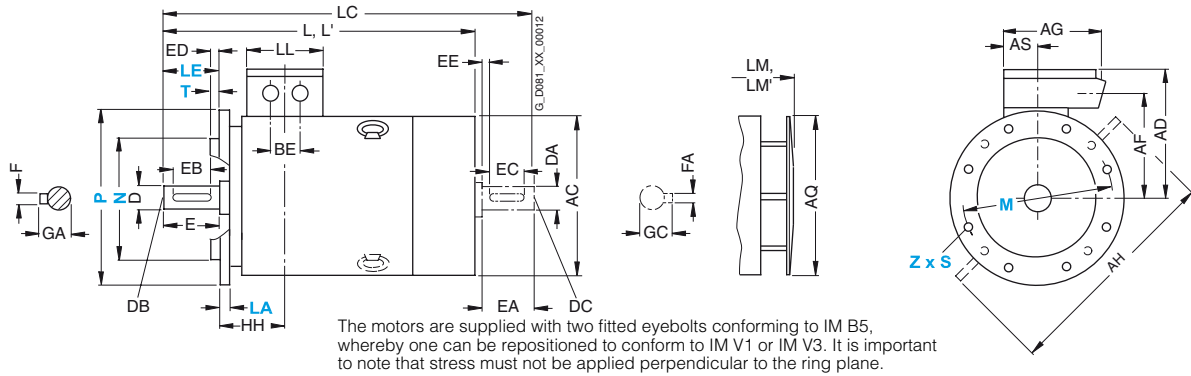

For motor		Number of poles	Dimension designation acc. to IEC																					
Frame size	Type		A	AA	AB	AC <sup>1)</sup>	AD	AD'	AF	AF'	AG	AH	AQ	AS	B*	BA	BA'	BB	BC	BE	C	CA*	H	HA
180 M	1LG6 183	2	279	65	339	363	262	262	220	220	152	452	340	71	241	70	111	328	36	54	121	253	180	20
		4																				202		
180 L	1LG6 186	4, 6, 8	279	65	339	363	262	262	220	220	152	452	340	71	279	70	111	328	36	54	121	215	180	20
		2, 6	318	70	378	402	300	300	247	247	260	512	340	96	305	80	80	355	63	85	133	177	200	25
200 L	1LG6 206	2, 6	318	70	378	402	300	300	247	247	260	512	340	96	305	80	80	355	63	85	133	234	200	25
		4, 8																				177		
225 S	1LG6 220	4, 8	356	80	436	442	325	325	272	272	260	556	425	96	286	85	110	361	47	85	149	218	225	34
		2	356	80	436	442	325	325	272	272	260	556	425	96	311	85	110	361	47	85	149	253	225	34
225 M	1LG6 223	4, 6, 8																						
		2	356	80	436	442	325	325	272	272	260	556	425	96	311	85	110	361	47	85	149	303	225	34
250 M	1LG6 253	2	406	100	490	495	392	392	308	308	300	620	470	118	349	100	100	409	69	110	168	235	250	40
		4																				305		
250 M	1LG6 258	6, 8																				235		
		2	406	100	490	495	392	392	308	308	300	620	470	118	349	100	100	409	69	110	168	305	250	40
		4, 6																						

\* This dimension is assigned in DIN EN 50347 to the frame size listed.

<sup>1)</sup> Measured across the bolt heads.

# IEC Squirrel-Cage Motors

## Standard motors up to frame size 315 L

### Dimensions

#### Dimensional drawings

Cast-iron series 1LG6, frame sizes 180 M to 250 M

#### Type of construction IM B35

For flange dimensions, see Page 2/140 (Z = the number of retaining holes)

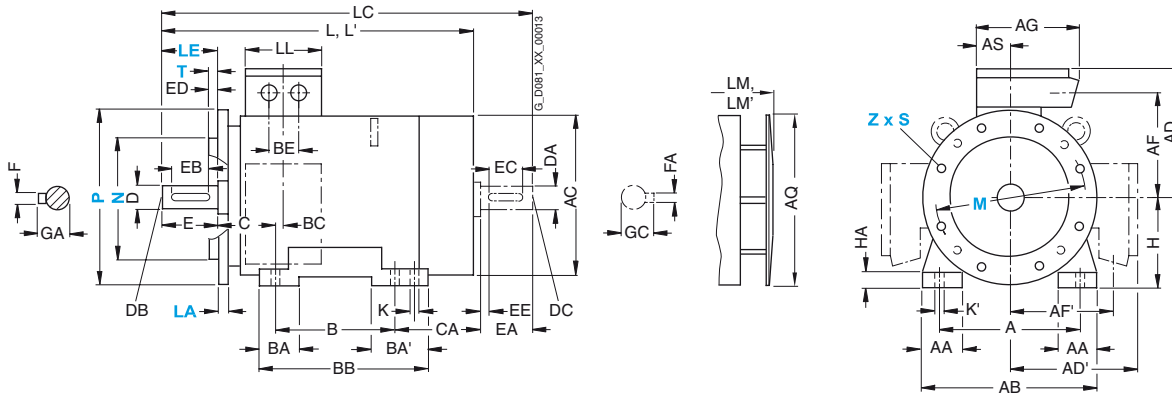

For motor		Number of poles	Dimension designation acc. to IEC								DE shaft extension					NDE shaft extension								
Frame size	Type		HH	K	K'	L	LC	LL	LM	D	DB	E	EB	ED	F	GA	DA	DC	EA	EC	EE	FA	GC	
180 M	1LG6 183	2	157	15	19	720	835	132	810	48	M16	110	100	5	14	51.5	48	M16	110	100	5	14	51.5	
		4				669	784		759															
		4, 6, 8				720	835	132	810	48	M16	110	100	5	14	51.5	48	M16	110	100	5	14	51.5	
200 L	1LG6 206	2, 6	196	19	25	720	835	192	810	55	M20	110	100	5	16	59	55	M20	110	100	5	16	59	
		2, 6	196	19	25	777	892	192	867	55	M20	110	100	5	16	59	55	M20	110	100	5	16	59	
		4, 8				720	835		810															
225 S	1LG6 220	4, 8	196	19	25	789	903	192	889	60	M20	140	125	10	18	64	55	M20	110	100	5	16	59	
		2	196	19	25	819	933	192	919	55	M20	110	100	5	16	59	48	M16	110	100	5	14	51.5	
		4, 6, 8				849	963		949	60	M20	140	125	10	18	64	55	M20	110	100	5	16	59	
225 M	1LG6 223	2	196	19	25	869	983	192	969	55	M20	110	100	5	16	59	48	M16	110	100	5	14	51.5	
		4, 6				899	1013		999	60	M20	140	125	10	18	64	55	M20	110	100	5	16	59	
		2	196	19	25	869	983	192	969	55	M20	110	100	5	16	59	48	M16	110	100	5	14	51.5	
250 M	1LG6 253	2	237	24	30	887	1002	236	987	60	M20	140	125	10	18	64	55	M20	110	100	5	16	59	
		4				957	1102		1057	65	M20	140	125	10	18	69	60	M20	140	125	10	18	64	
		6, 8				887	1032		987	65	M20	140	125	10	18	69	60	M20	140	125	10	18	64	
	1LG6 258	2	237	24	30	957	1102	236	1057	60	M20	140	125	10	18	64	55	M20	110	100	5	16	59	
		4, 6								65	M20	140	125	10	18	69	60	M20	140	125	10	18	64	
		2	237	24	30	957	1102	236	1057	60	M20	140	125	10	18	64	55	M20	110	100	5	16	59	

# IEC Squirrel-Cage Motors

## Standard motors up to frame size 315 L

### Dimensions

2

#### Dimensional drawings

Cast-iron series 1LG6, frame sizes 280 S to 315 L

#### Type of construction IM B3

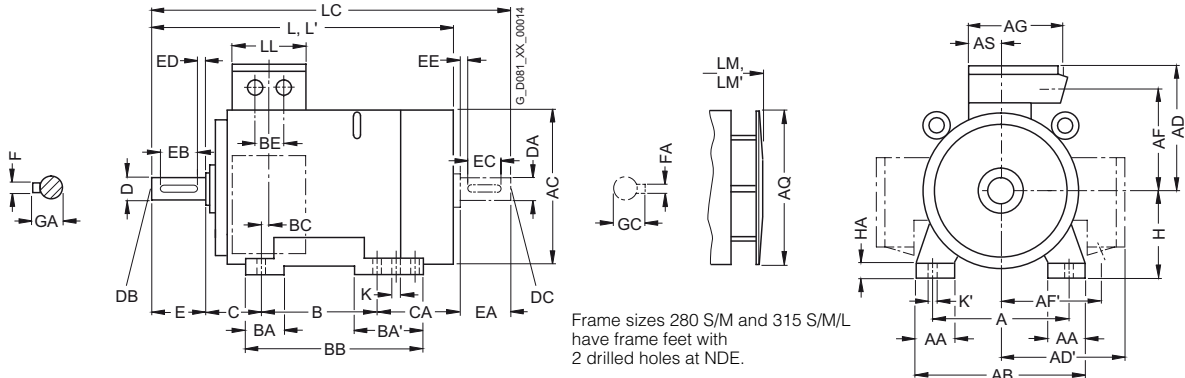

#### Types of construction IM B5 and IM V1

For flange dimensions, see Page 2/140 (Z = the number of retaining holes)

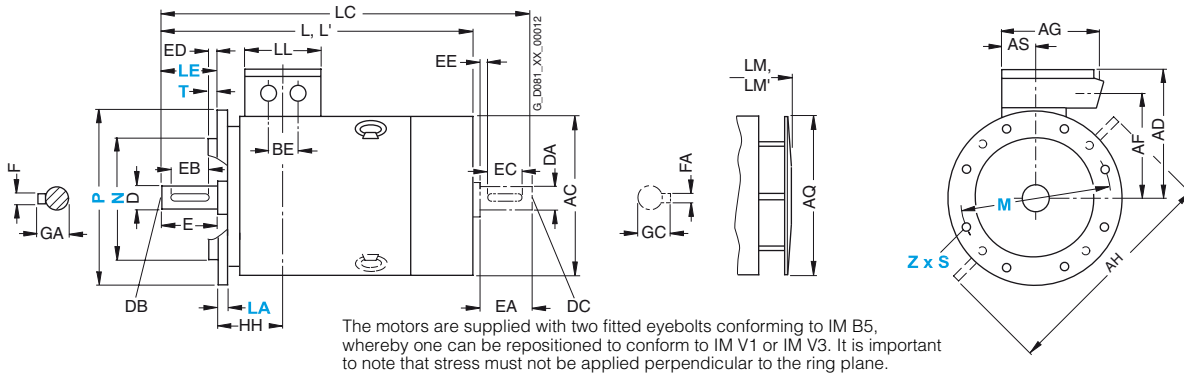

For motor	Frame size	Type	Number of poles	Dimension designation acc. to IEC																					
				A	AA	AB	AC <sup>1)</sup>	AD	AD'	AF	AF'	AG	AH	AQ	AS	B*	BA	BA'	BB	BC	BE	C	CA*	H	HA
	280 S	1LG6 280	2	457	100	540	555	432	432	348	348	300	672	525	118	368	100	151	479	62	110	190	267	280	40
	280 M	1LG6 283	2	457	100	540	555	432	432	348	348	300	672	525	118	419	100	151	479	62	110	190	326	280	40
			4	672	525	118	419	100	151	479	62	110	190	326	280	40									
		1LG6 288	2	457	100	540	555	432	432	348	348	300	672	525	118	419	100	151	479	62	110	190	326	280	40
			4																			216	280	40	
	315 S	1LG6 310	2	508	120	610	610	500	500	400	400	380	780	590	154	406	125	176	527	69	110	216	315	315	50
		1LG6 310	4, 6, 8																						
	315 M <sup>2)</sup>	1LG6 313	8	508	120	610	610	500	500	400	400	380	780	590	154	457	125	176	527	69	110	216	264	315	50
			2	508	120	610	610	500	500	400	400	380	780	590	154	457	125	176	578	69	110	216	424	315	50
	315 L <sup>2)</sup>	1LG6 313	4, 6																						
		1LG6 316	2	508	120	610	610	500	500	400	400	380	780	590	154	508	125	176	578	69	110	216	373	315	50
		1LG6 316	4, 6																						
		1LG6 316	8																						
		1LG6 317	2	508	120	610	610	500	500	400	400	380	780	590	154	508	155	206	648	69	110	216	513	315	50
		1LG6 317	4, 6																						
		1LG6 317	8																						
		1LG6 318	2	508	120	610	610	651	651	524	524	470	780	590	165	508	155	206	648	69	135	216	513	315	50
		1LG6 318	4																						
		1LG6 318	6, 8					500	500	400	400	380													

\* This dimension is assigned in DIN EN 50347 to the frame size listed.

1) Measured across the bolt heads.

2) With order codes for connection box positions (K09, K10, K11) only fitted feet with 3 drilled holes with dimension "B" (406, 457 and 508 mm). BB will then be 666 mm.



# IEC Squirrel-Cage Motors

## Standard motors up to frame size 315 L

### Dimensions

#### Dimensional drawings

Cast-iron series 1LG6, frame sizes 280 S to 315 L

#### Type of construction IM B35

For flange dimensions, see Page 2/140 (Z = the number of retaining holes)

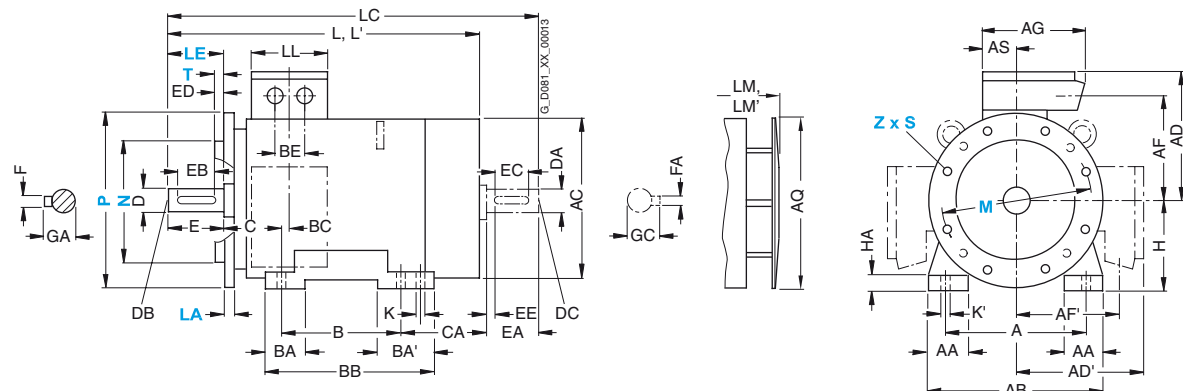

For motor Frame size	Type	Number of poles	Dimension designation acc. to IEC								DE shaft extension				NDE shaft extension								
			HH	K	K'	L	LC	LL	LM	D	DB	E	EB	ED	F	GA	DA	DC	EA	EC	EE	FA	GC
280 S	1LG6 280	2	252	24	30	960	1105	236	1070	65	M20	140	125	10	18	69	60	M20	140	125	10	18	64
		4, 6, 8								75	M20	140	125	10	20	79.5	65	M20	140	125	10	18	69
	280 M	1LG6 283	2	252	24	30	1070	1215	236	1180	65	M20	140	125	10	18	69	60	M20	140	125	10	18
4										75	M20	140	125	10	20	79.5	65	M20	140	125	10	18	69
6, 8					960	1105		1070	75	M20	140	125	10	20	79.5	65	M20	140	125	10	18	69	
	1LG6 288	2	252	24	30	1070	1215	236	1180	65	M20	140	125	10	18	69	60	M20	140	125	10	18	64
		4, 6								75	M20	140	125	10	20	79.5	65	M20	140	125	10	18	69
315 S	1LG6 310	2	285	28	35	1072	1217	307	1182	65	M20	140	125	10	18	69	60	M20	140	125	10	18	64
	1LG6 310	4, 6, 8				1102	1247		1212	80	M20	170	140	25	22	85	70	M20	140	125	10	20	74.5
315 M	1LG6 313	8	285	28	35	1102	1247	307	1212	80	M20	170	140	25	22	85	70	M20	140	125	10	20	74.5
	1LG6 313	2	285	28	35	1232	1377	307	1342	65	M20	140	125	10	18	69	60	M20	140	125	10	18	64
315 L	1LG6 313	4, 6				1262	1407		1372	80	M20	170	140	25	22	85	70	M20	140	125	10	20	74.5
	1LG6 316	2	285	28	35	1232	1377	307	1342	65	M20	140	125	10	18	69	60	M20	140	125	10	18	64
	1LG6 316	4, 6				1262	1407		1372	80	M20	170	140	25	22	85	70	M20	140	125	10	20	74.5
	1LG6 316	8								80	M20	170	140	25	22	85	70	M20	140	125	10	20	74.5
	1LG6 317	2	285	28	35	1372	1517	307	1482	65	M20	140	125	10	18	69	60	M20	140	125	10	18	64
	1LG6 317	4, 6				1402	1547		1512	80	M20	170	140	25	22	85	70	M20	140	125	10	20	74.5
	1LG6 317	8				1262	1407		1372	80	M20	170	140	25	22	85	70	M20	140	125	10	20	74.5
	1LG6 318	2	285	28	35	1372	1517	330	1482	65	M20	140	125	10	18	69	60	M20	140	125	10	18	64
1LG6 318	4				1402	1547		1512	80 <sup>1)</sup>	M20	170	140	25	22	85	70	M20	140	125	10	20	74.5	
1LG6 318	6, 8							307	80	M20	170	140	25	22	85	70	M20	140	125	10	20	74.5	

<sup>1)</sup> Diameters up to 90 mm are possible.

# IEC Squirrel-Cage Motors

## Standard motors up to frame size 315 L

### Dimensions

#### Dimensional drawings

Aluminum series 1LP7 and 1LP5, frame sizes 63 M to 200 L

#### Type of construction IM B3

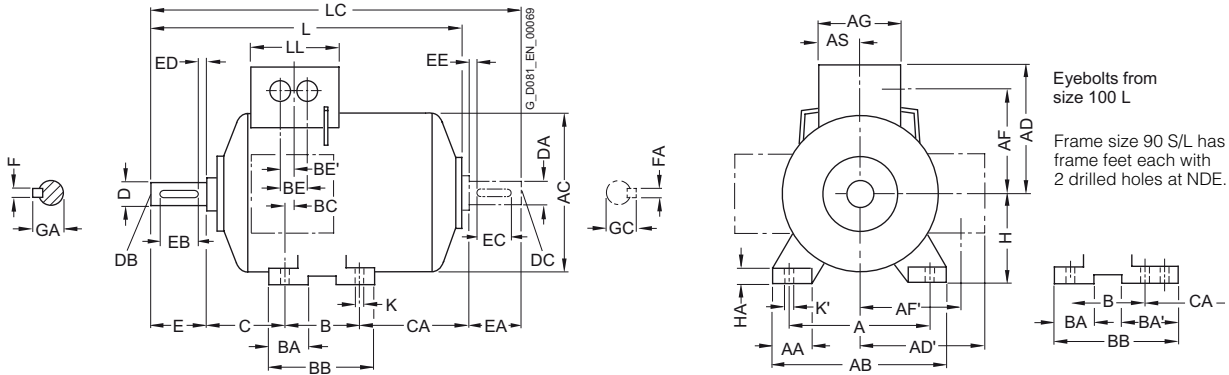

#### Types of construction IM B5 and IM V1

For flange dimensions, see Page 2/140 (Z = the number of retaining holes)

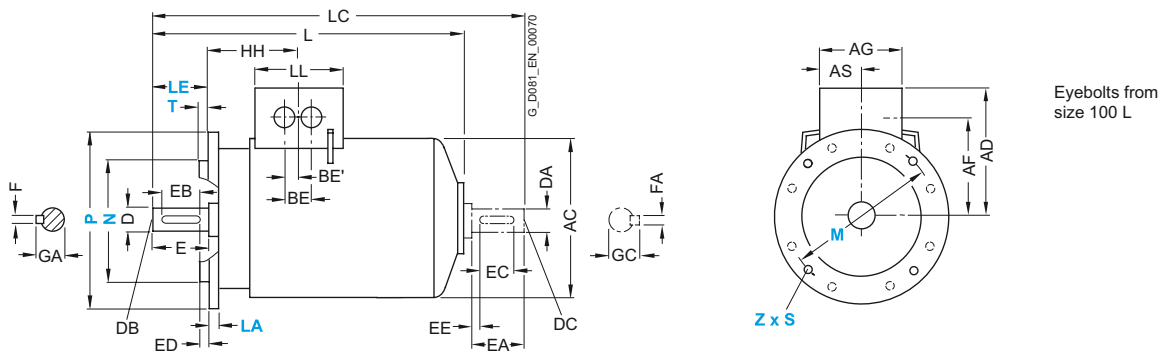

For motor			Dimension designation acc. to IEC																				
Frame size	Type	Number of poles	A	AA	AB	AC	AD	AD'	AF	AF'	AG	AS	B*	BA	BA'	BB	BC	BE	BE'	C	CA*	H	HA
63 M	1LP7 060 1LP7 063	2, 4, 6	100	27	120	124	101	101	78	78	75	37.5	80	28	-	96	30	32	18	40	40	63	7
71 M	1LP7 070 1LP7 073	2, 4, 6, 8	112	27	132	145	111	111	88	88	75	37.5	90	27	-	106	18	32	18	45	42	71	7
80 M	1LP7 080 1LP7 083	2, 4, 6, 8	125	30.5	150	163	120	120	97	97	75	37.5	100	32	-	118	14	32	18	50	47	80	8
90 S 90 L	1LP7 090 1LP7 096	2, 4, 6, 8	140	30.5	165	180	128	128	105	105	75	37.5	100 125	33	54	143	23	32	18	56	80 55	90	10
100 L	1LP7 106 1LP7 107	2, 4, 6, 8 4, 8	160	42	196	203	135	163	78	123	120	60	140	47	-	176	39	42	21	63	68	100	12
112 M	1LP7 113	2, 4, 6, 8	190	46	226	227	148	176	91	136	120	60	140	47	-	176	32	42	21	70	79	112	12
132 S	1LP7 130 1LP7 131	2, 4, 6, 8 2	216	53	256	267	167	194	107	154	140	70	140	49	-	180	39	42	21	89	96	132	15
132 M	1LP7 133 1LP7 134	4, 6, 8 6	216	53	256	267	167	194	107	154	140	70	178	49	-	218	39	42	21	89	58	132	15
160 M	1LP7 163 1LP7 164	2, 4, 6, 8 2, 8	254	60	300	320	197	226	127	183	165	82.5	210	57	-	256	52.5	54	27	108	107	160	18
160 L	1LP7 166	2, 4, 6, 8	254	60	300	320	197	226	127	183	165	82.5	254	57	-	300	52.5	54	27	108	63	160	18
180 M	1LP5 183	2, 4	279	69.5	339	363	258	258	216	216	152	71	241	50	-	287	38	54	27	121	145	180	18
180 L	1LP5 186	4, 6, 8	279	69.5	339	363	258	258	216	216	152	71	279	50	-	325	38	54	27	121	107	180	18
200 L	1LP5 206 1LP5 207	2, 6 2, 4, 6, 8	318	83	388	402	305	305	252	252	260	96	305	58.5	-	355	45	85	42.5	133	133	200	24

\* This dimension is assigned in DIN EN 50347 to the frame size listed.

# IEC Squirrel-Cage Motors

## Standard motors up to frame size 315 L

### Dimensions

#### Dimensional drawings

##### Aluminum series 1LP7 and 1LP5, frame sizes 63 M to 200 L

##### Types of construction IM B35

For flange dimensions, see Page 2/140 (Z = the number of retaining holes)

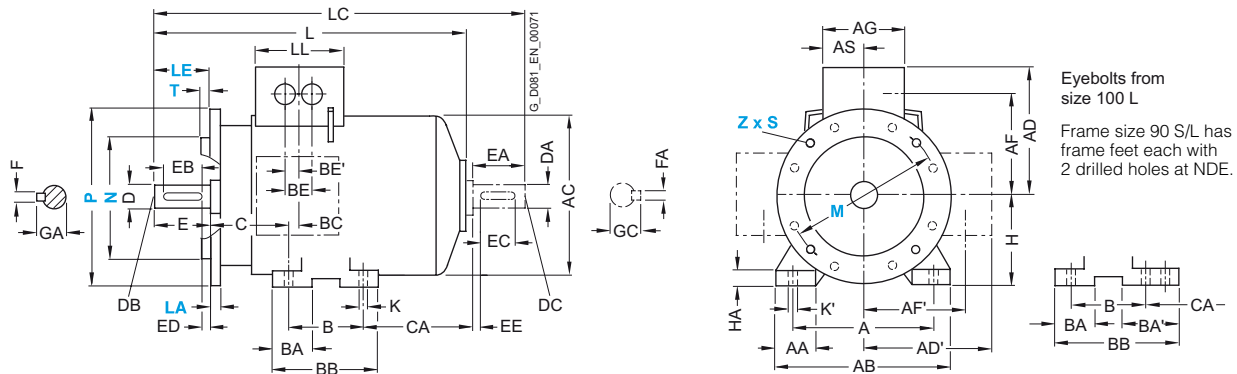

##### Type of construction IM B14

Type of construction IM B14 not possible for 1LP5 motors, frame sizes 180 M to 200 L

For flange dimensions, see Page 2/140 (Z = the number of retaining holes)

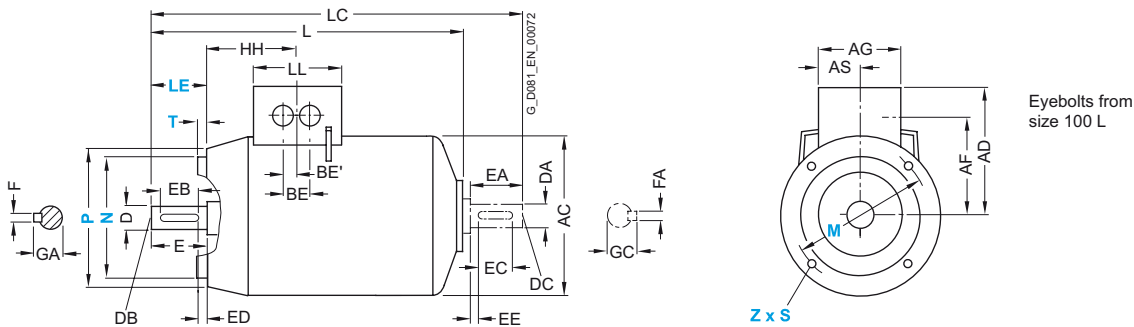

For motor		Number of poles	Dimension designation acc. to IEC						DE shaft extension					NDE shaft extension								
Frame size	Type		HH	K	K'	L	LC	LL	D	DB	E	EB	ED	F	GA	DA	DC	EA	EC	EE	FA	GC
63 M	1LP7 060 1LP7 063	2, 4, 6	69.5	7	10	172 <sup>1)</sup>	206 <sup>1)</sup>	75	11	M4	23	16	3.5	4	12.5	11	M4	23	16	3.5	4	12.5
71 M	1LP7 070 1LP7 073	2, 4, 6, 8	63.5	7	10	207	240	75	14	M5	30	22	4	5	16	14	M5	30	22	4	5	16
80 M	1LP7 080 1LP7 083	2, 4, 6, 8	63.5	9.5	13.5	237	280	75	19	M6	40	32	4	6	21.5	19	M6	40	32	4	6	21.5
90 S 90 L	1LP7 090 1LP7 096	2, 4, 6, 8	79	10	14	286 286	333 333	75	24	M8	50	40	5	8	27	19	M6	40	32	4	6	21.5
100 L	1LP7 106 1LP7 107	2, 4, 6, 8 4, 8	102	12	16	331	385 <sup>2)</sup>	120	28	M10	60	50	5	8	31	24	M8	50	40	5	8	27
112 M	1LP7 113	2, 4, 6, 8	102	12	16	349 <sup>3)</sup>	403 <sup>4)</sup>	120	28	M10	60	50	5	8	31	24	M8	50	40	5	8	27
132 S	1LP7 130 1LP7 131	2, 4, 6, 8 2	128	12	16	397	485	140	38	M12	80	70	5	10	41	38	M12	80	70	5	10	41
132 M	1LP7 133 1LP7 134	4, 6, 8 6	128	12	16	397	485	140	38	M12	80	70	5	10	41	38	M12	80	70	5	10	41
160 M	1LP7 163 1LP7 164	2, 4, 6, 8 2, 8	160.5	15	19	529	645	165	42	M16	110	90	10	12	45	42	M16	110	90	10	12	45
160 L	1LP7 166	2, 4, 6, 8	160.5	15	19	529	645	165	42	M16	110	90	10	12	45	42	M16	110	90	10	12	45
180 M	1LP5 183	2, 4	159	15	19	611	727	132	48	M16	110	100	5	14	51.5	48	M16	110	100	5	14	51.5
180 L	1LP5 186	4, 6, 8	159	15	19	611	727	132	48	M16	110	100	5	14	51.5	48	M16	110	100	5	14	51.5
200 L	1LP5 206 1LP5 207	2, 6 2, 4, 6, 8	178	19	25	675	791	192	55	M20	110	100	5	16	59	55	M20	110	100	5	16	59

<sup>1)</sup> For 1LP7 063 with type of construction code 1 (B5, IM V1 without protective cover, IM V3) the dimensions L and LC are 26 mm longer.

<sup>2)</sup> For IM B14, 381 mm.

<sup>3)</sup> For IM B5, 345 mm.

<sup>4)</sup> For IM B5, 399 mm.

# IEC Squirrel-Cage Motors

## Standard motors up to frame size 315 L

### Dimensions

#### Dimensional drawings

Cast-iron series 1LP4, frame sizes 180 M to 315 L

#### Type of construction IM B3

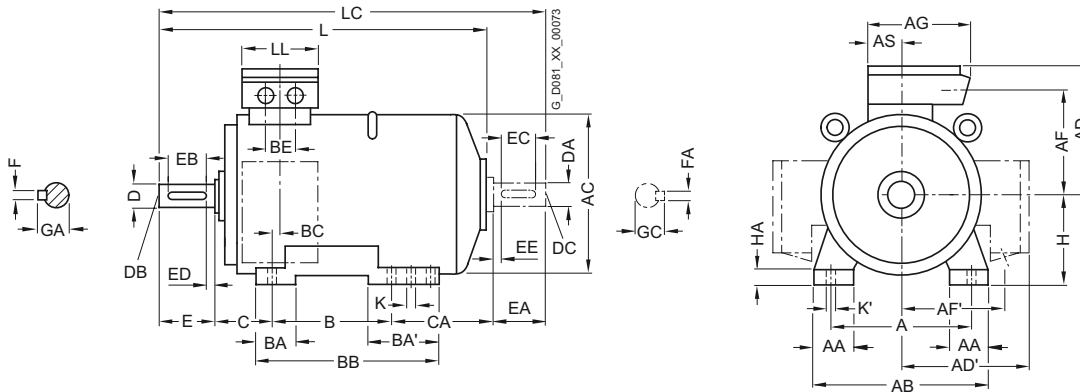

Frame sizes 180 M/L, 225 S/M, 280 S/M and 315 S/M/L have frame feet each with 2 drilled holes at NDE.

#### Types of construction IM B5 and IM V1 (IM B5 only up to frame size 315 M)

For flange dimensions, see Page 2/140 (Z = the number of retaining holes)

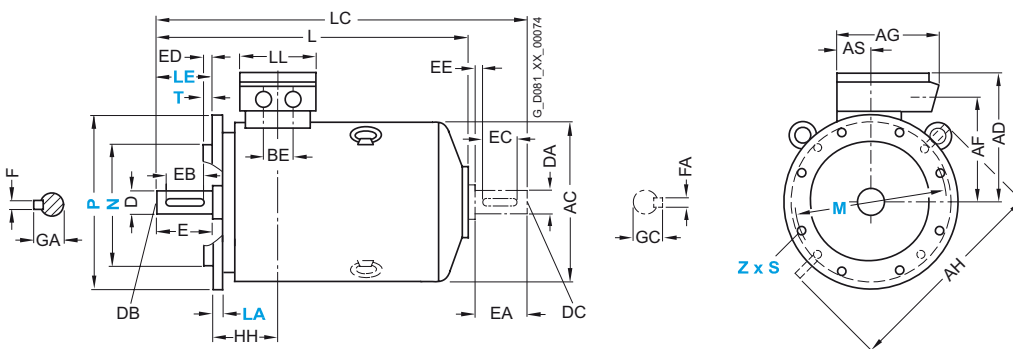

The motors are supplied with two fitted eyebolts conforming to IM B5, whereby one can be repositioned to conform to IM V1 or IM V3. It is important to note that stress must not be applied perpendicular to the ring plane.

For motor			Dimension designation acc. to IEC																				
Frame size	Type	Number of poles	A	AA	AB	AC	AD	AD'	AF	AF'	AG	AH	AS	B*	BA	BA'	BB	BC	BE	C	CA*	H	HA
180 M	1LP4 183	2, 4	279	65	339	363	262	262	220	220	152	452	71	241	70	111	328	36	54	121	94	180	20
180 L	1LP4 186	4, 6, 8	279	65	339	363	262	262	220	220	152	452	71	279	70	111	328	36	54	121	56	180	20
200 L	1LP4 206	2, 6	318	70	378	402	300	300	247	247	260	512	96	305	80	80	355	63	85	133	76	200	25
	1LP4 207	2, 4, 6, 8	318	70	378	402	300	300	247	247	260	512	96	305	80	80	355	63	85	133	76	200	25
225 S	1LP4 220	4, 8	356	80	436	442	325	325	272	272	260	556	96	286	85	110	361	47	85	149	99	225	34
225 M	1LP4 223	2	356	80	436	442	325	325	272	272	260	556	96	311	85	110	361	47	85	149	74	225	34
		4, 6, 8																					
250 M	1LP4 253	2	406	100	490	495	392	392	308	308	300	620	118	349	100	100	409	69	110	168	111	250	40
		4, 6, 8																					
280 S	1LP4 280	2	457	100	540	555	432	432	348	348	300	672	118	368	100	151	479	62	110	190	137	280	40
		4, 6, 8																					
280 M	1LP4 283	2	457	100	540	555	432	432	348	348	300	672	118	414	100	151	479	62	110	190	86	280	40
		4, 6, 8																					
315 S	1LP4 310	2	508	120	610	610	500	500	400	400	380	780	154	406	125	176	527	69	110	216	168	315	50
	1LP4 310	4, 6, 8																					
315 M <sup>1)</sup>	1LP4 313	2	508	120	610	610	500	500	400	400	380	780	154	457	125	176	527	69	110	216	117	315	50
	1LP4 313	4, 6, 8																					
315 L <sup>1)</sup>	1LP4 316/317	2	508	120	610	610	500	500	400	400	380	780	154	508	125	176	578	69	110	216	226	315	50
	1LP4 316/317	4, 6, 8																					

\* This dimension is assigned in DIN EN 50347 to the frame size listed.

<sup>1)</sup> With order codes for connection box positions (K09, K10, K11) only fitted feet with 3 drilled holes with dimension "B" (406, 457 and 508 mm). BB will then be 666 mm.

# IEC Squirrel-Cage Motors

## Standard motors up to frame size 315 L

### Dimensions

#### Dimensional drawings

Cast-iron series 1LP4, frame sizes 180 M to 315 L

#### Type of construction IM B35

For flange dimensions, see Page 2/140 (Z = the number of retaining holes)

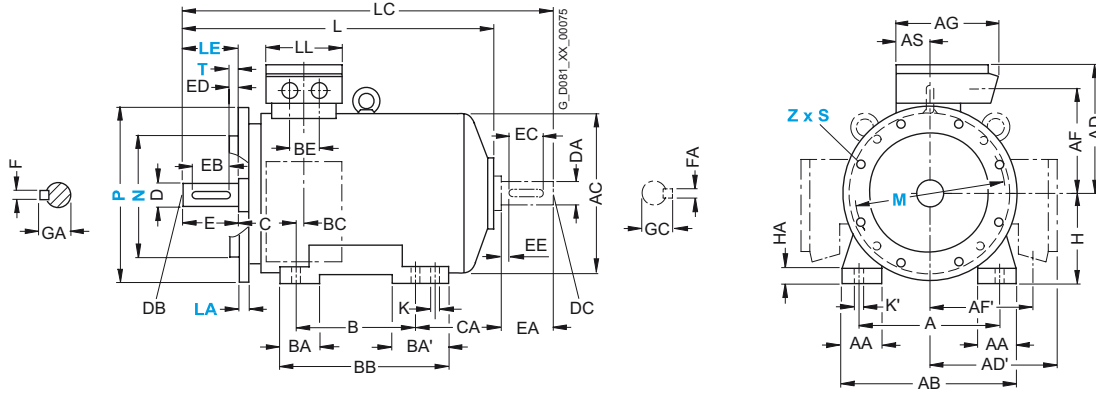

For motor		Number of poles	Dimension designation acc. to IEC						DE shaft extension					NDE shaft extension								
Frame size	Type		HH	K	K'	L	LC	LL	D	DB	E	EB	ED	F	GA	DA	DC	EA	EC	EE	FA	GC
180 M	1LP4 183	2, 4	157	15	19	562	676	132	48	M16	110	100	5	14	51.5	48	M16	110	100	5	14	51.5
180 L	1LP4 186	4, 6, 8	157	15	19	562	676	132	48	M16	110	100	5	14	51.5	48	M16	110	100	5	14	51.5
200 L	1LP4 206	2, 6	196	19	25	617	734	192	55	M20	110	100	5	16	59	55	M20	110	100	5	16	59
	1LP4 207	2, 4, 6, 8	196	19	25	617	734	192	55	M20	110	100	5	16	59	55	M20	110	100	5	16	59
225 S	1LP4 220	4, 8	196	19	25	670	784	192	60	M20	140	125	10	18	64	55	M20	110	100	5	16	59
225 M	1LP4 223	2	196	19	25	640	754	192	55	M20	110	100	5	16	59	48	M16	110	100	5	14	51.5
		4, 6, 8				670	784		60	M20	140	125	10	18	64	55	M20	110	100	5	16	59
250 M	1LP4 253	2	237	24	30	764	878	236	60	M20	140	125	10	18	64	55	M20	110	100	5	16	59
		4, 6, 8					908		65	M20	140	125	10	18	69	60	M20	140	125	10	18	64
280 S	1LP4 280	2	252	24	30	830	975	236	65	M20	140	125	10	18	69	60	M20	140	125	10	18	64
		4, 6, 8							75	M20	140	125	10	20	79.5	65	M20	140	125	10	18	69
280 M	1LP4 283	2	252	24	30	830	975	236	65	M20	140	125	10	18	69	60	M20	140	125	10	18	64
		4, 6, 8							75	M20	140	125	10	20	79.5	65	M20	140	125	10	18	69
315 S	1LP4 310	2	285	28	35	925	1070	307	65	M20	140	125	10	18	69	60	M20	140	125	10	18	64
	1LP4 310	4, 6, 8				955	1100		80	M20	170	140	25	22	85	70	M20	140	125	10	20	74.5
315 M <sup>1)</sup>	1LP4 313	2	285	28	35	925	1070	307	65	M20	140	125	10	18	69	60	M20	140	125	10	18	64
	1LP4 313	4, 6, 8				955	1100		80	M20	170	140	25	22	85	70	M20	140	125	10	20	74.5
315 L <sup>1)</sup>	1LP4 316/317	2	285	28	35	1085	1230	307	65	M20	140	125	10	18	69	60	M20	140	125	10	18	64
	1LP4 316/317	4, 6, 8				1115	1260		80	M20	170	140	25	22	85	70	M20	140	125	10	20	74.5

<sup>1)</sup> With order codes for connection box positions (K09, K10, K11) only fitted feet with 3 drilled holes with dimension "B" (406, 457 and 508 mm). BB will then be 666 mm.



# Non-standard motors frame size 315 and above



3/2	<b>Orientation</b>	3/34	<b>Self-ventilated motors with through ventilation for mains-fed operation Cast-iron series 1LL8</b>
3/2	Overview	3/34	Selection and ordering data
3/2	Benefits		
3/3	Application		
3/3	Design		
3/4	Technical specifications		
3/11	Selection and ordering data		
3/13	More information		
3/14	<b>Self-ventilated motors for mains-fed operation Cast-iron series 1LA8</b>	3/38	<b>Self-ventilated motors with through ventilation for converter-fed operation Cast-iron series 1LL8</b>
3/14	Selection and ordering data	3/38	Selection and ordering data
3/18	<b>Self-ventilated motors for converter-fed operation Cast-iron series 1LA8</b>	3/46	<b>Special versions</b>
3/18	Selection and ordering data	3/46	Overview
		3/47	Selection and ordering data
		3/47	• Voltages
		3/50	• Options
3/26	<b>Forced-air cooled motors with separately driven fan for converter-fed operation Cast-iron series 1PQ8</b>	3/62	<b>Accessories</b>
3/26	Selection and ordering data	3/62	Overview
		3/62	More information
		3/63	<b>Dimensions</b>
		3/63	Overview
		3/64	Dimensional drawings

# IEC Squirrel-Cage Motors

## Non-standard motors frame size 315 and above

### Orientation

#### Overview



**N compact three-phase asynchronous motors: Series 1LA8, 1PQ8, 1LL8**

The three-phase motor series N compact covers outputs up to 1250 kW (at 50 Hz) in the non-standard range. A number of technical features provide this motor series with its ruggedness and long service life and ensure the highest level of availability.

N compact motors are also characterised by their high output for small frame size. The consequence of this is an extremely compact design that can be used to save space in a number of industrial applications.

N compact motors are not only optimised in terms of their construction, but also in terms of their efficiency, so they also contribute towards lower energy consumption.

Apart from mains-fed operation, the motors of the series N compact are also specially designed for converter-fed operation. In combination with frequency converters from the SINAMICS and SIMOVERT MASTERDRIVES product series, they build up perfectly interacting drive systems for variable-speed drive applications.

#### Versions in the N compact series

##### Series 1LA8

The motors are asynchronous squirrel-cage motors with compact dimensions in fin-cooled design. They are designed for direct connection to the three-phase supply and for converter-fed operation.

- *1LA8 for mains-fed operation*
  - Designed for operation on the three-phase supply
  - Degree of protection: IP55
  - Cooling method: IC411, self-ventilated
  - Housing: Cast iron

- *1LA8 for converter-fed operation*
  - Converter-fed operation, optimised for the SINAMICS and SIMOVERT MASTERDRIVES drive systems
  - Degree of protection: IP55
  - Cooling method: IC411, self-ventilated
  - Housing: Cast iron
  - With standard insulation for voltages  $\leq 500$  V or with special insulation for 690 V

##### Series 1PQ8

The motors are asynchronous squirrel-cage motors with compact dimensions in fin-cooled design with forced ventilation. As these motors are forced-ventilated, no derating or only relatively minor derating (depending on their speed range) is required for operation at constant load torque and with wide speed ranges. The motors are designed for converter-fed operation with the SINAMICS and SIMOVERT MASTERDRIVES drive system.

- Converter-fed operation
- Degree of protection: IP55
- Cooling method: IC416, forced-ventilated
- Housing: Cast iron
- With standard insulation for voltages  $\leq 500$  V or with special insulation for 690 V

##### Series 1LL8

The motors of series 1LL8 are asynchronous squirrel-cage motors with compact dimensions in an open fin-cooled design with self-cooling. They are similar in construction to 1LA8 motors. IP23 degree of protection is achieved by opening the internal cooling circuit and supplying it with external cooling air. This can increase the performance by up to 25 % as compared to the 1LA8. They are designed for direct connection to the three-phase supply and for converter-fed operation.

Motors of the 1LL8 type series are intended for installation indoors. They must not be subjected to humid, salty or corrosive atmospheres.

- *1LL8 for mains-fed operation*
  - Mains-fed operation
  - Degree of protection: IP23
  - Cooling method: IC01, self-ventilated
  - Housing: Cast iron
- *1LL8 for converter-fed operation*
  - Converter-fed operation
  - Degree of protection: IP23
  - Cooling method: IC01, self-ventilated
  - Housing: Cast iron

Versions with special insulation for  $>500$ V and operation without an output filter on the frequency converter are only possible on request.

#### Benefits

Non-standard motors from Siemens offer the user numerous advantages:

- The optimised efficiency results in lower operating costs.
- The high output/size ratio ensures low space requirements combined with low weight.
- The cast-iron housing and bearing plates are extremely rigid and rugged and can therefore be subjected to considerable stress and have excellent vibration damping properties and are resistant to corrosion.
- The bearings are designed for maximum reliability, which results in good vibration characteristics, a long service life and low maintenance costs.
- The DURIGNIT IR 2000 insulation system with VPI or current-UV impregnation results in high reliability, a long service life and high resistance to stress, for example, during starting or under overload conditions.
- Due to the low noise emission level, the stringent requirements of worker protection are fulfilled without the need for additional measures.



# IEC Squirrel-Cage Motors

## Non-standard motors frame size 315 and above

Orientation

### Application

Thanks to the many options, the three-phase motor series N compact covers applications in a wide range of different sectors: Chemicals, paper, water/waste water, steel and shipbuilding are just a few examples. The available types of construction are IM B3, IM B35 and IM V1 according to DIN EN 60034-7. The degree of protection is IP55 as standard, but IP23 for motor series 1LL8.

The 1PQ8 motors are specially designed for variable-speed applications with constant torque. The mounted separately driven fan provides a constantly high cooling air flow at any speed. These motors can therefore be continuously operated at low speed and high torque simultaneously.

The low-voltage motor series N compact is also available in a through-ventilated version to IP23 degree of protection. This 1LL8 motor series boasts an output 25 % higher than that of the closed 1LA8 motor series for the same frame size. The 1LL8 motor is therefore useful for applications in which a closed 1LA8 motor is not essential and when the ambient conditions permit the use of a through-ventilated machine (IC 01 cooling method, IP23 degree of protection). Motors of the 1LL8 type series are only intended for installation indoors. They must not be subjected to humid, salty or corrosive atmospheres.

### Design

The basic structure of the non-standard motors is shown in the following sectional diagram.

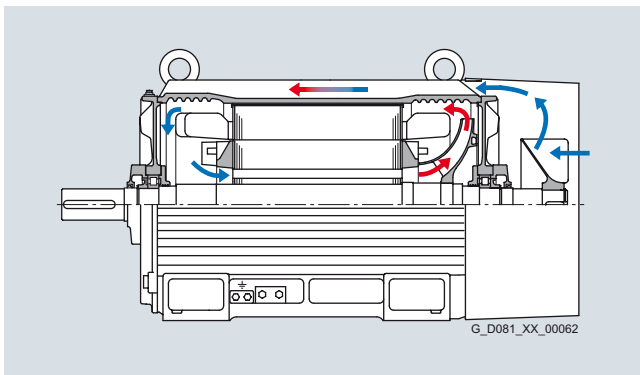

Sectional diagram of 1LA8

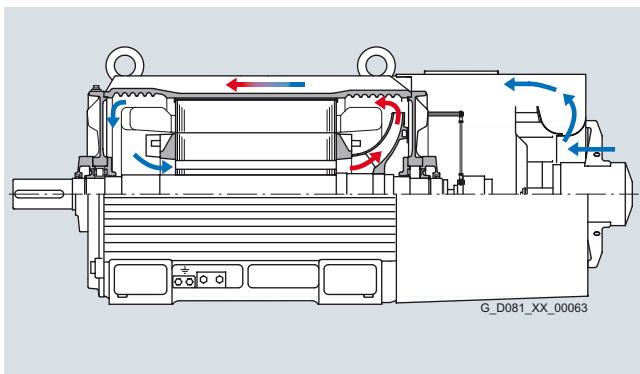

Sectional diagram of 1PQ8

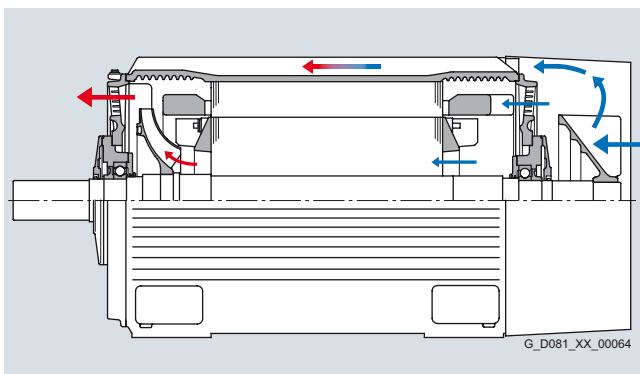

Sectional diagram of 1LL8

In conventional fin-cooled motors, the one-sided external ventilation naturally results in an uneven temperature distribution – this is however not the case with N compact motors with their additional internal air-flow channels. This cools, in particular, the stator winding heads, the rotor winding and the drive-end bearings. The resulting reduction in thermal loading increases the operating reliability and lengthens the service life. The internal air-flow channels increase the efficiency of the ventilation which means that the external air-flow can be reduced. The lower volumetric flow and air-flow optimisation of all guide channels results in a low level of fan noise.

3

# IEC Squirrel-Cage Motors

## Non-standard motors frame size 315 and above

### Orientation

#### Technical specifications

The following table lists the most important technical specifications. For further information and details, see catalog part 0 "Introduction".

#### Technical specifications at a glance

Type of motor	Squirrel-cage induction motor
Connection types	Star/delta connection You can establish the connection type used from the Order No. supplements in the selection and ordering data for the required motor.
Number of poles	2, 4, 6, 8
Rated output	160 ... 1250 kW (at 50 Hz)
Rated speed (synchronous speed)	750 ... 3600 rpm
Rated torques	800 ... 10,300 Nm
Insulation of the stator winding according to EN 60034-1 (IEC 60034-1)	Temperature class 155 (F) Used in mains-fed operation (at rated output) as: temperature class 130 (B) Used in converter-fed operation (at rated output): temperature class 155 (F) For coolant temperatures of up to 40 °C as standard DURIGNIT IR 2000 insulation system with impregnation by VPI or current-UV technique
Degree of protection according to EN 60034-5 (IEC 60034-5)	Motor series 1LA8 and 1PQ8: IP55 Motor series 1LL8: IP23
Cooling according to EN 60034-6 (IEC 60034-6)	Self-ventilated (motor series 1LA8) Motor frame sizes 315 to 450 (IC 411) Forced-air cooled (motor series 1PQ8) Motor frame sizes 315 to 450 (IC 416) Self-ventilated (motor series 1LL8) Motor frame sizes 315 to 450 (IC 01)
Admissible coolant temperature	See "Coolant temperature and site altitude" in catalog part 0 "Introduction"
Standard voltages according to EN 60038 (IEC 60038)	50 Hz: 400 V, 500 V, 690 V The voltage used can be found in the selection and ordering data for the required motor.
Type of construction according to EN 60034-7 (IEC 60034-7)	<u>Without flange:</u> IM B3 <u>With flange:</u> IM V1 without protective cover, IM V1 with protective cover, IM B35
Frame design	Cast-iron with cast frame feet for IM B3 and IM B35 types of construction
Paint finish Suitability of paint finish for climate group in accordance with IEC 60721, Part 2-1	<u>Standard:</u> Standard paint finish (moderate = expanded) RAL 7030 stone gray
Vibration quantity level according to EN 60034-14 (IEC 60034-14)	Level A (standard- without special vibration requirements) optional: Level B (with special vibration requirements)
Shaft extension according to DIN 748 (IEC 60072)	With featherkey, half-key balancing
Shaft and flange accuracy according to DIN 42955 (IEC 60072-1)	Tolerance N (normal) <u>Optional:</u> Tolerance R (reduced)
Sound pressure level to DIN EN ISO 1680 (tolerance +3 dB)	The sound pressure level is listed in the selection and ordering data for the required motor.
Weights	The weight is listed in the selection and ordering data for the required motor.
Mechanical limit speeds	The limit speed is listed in the selection and ordering data for the required motor.
Packing weights and dimensions	See "Packing weights and packing dimensions" in catalog part 0 "Introduction".
Rating plates	Fixed to the motor (optionally: 1 additional set of rating plates, loose), labeled as standard in English/German, can be supplied in French/Spanish, Italian or Portuguese without additional charge See "Rating plate" in catalog part 0 "Introduction".
Connection and connection boxes	See "Connection, circuit and connection box" in catalog part 0 "Introduction".
Bearing design	See "Bearings" in catalog part 0 "Introduction".
Cantilever forces	See "Admissible cantilever forces" in catalog part 0 "Introduction"
Pulse encoder	See "Special technology" in catalog part 0 "Introduction"
Options	See the selection and ordering data for "Special versions"

# IEC Squirrel-Cage Motors

## Non-standard motors frame size 315 and above

Orientation

### Technical specifications (continued)

#### Rating plate

According to DIN EN 60034-1, the approximate overall weight is specified on the rating plate for all motors of frame size 90 and above (from approx. 30 kg).

For all motors, an additional rating plate can be supplied loose, order code **K31**. An extra rating plate for identification codes is also possible, order code **Y82**. In the standard version, the rating plate is available in English and German.

SIEMENS										
15	3-MOT. 1LA8 317-4AB60-Z NoN- R41124661010001/2003 IMB3 Th.CI.155(F)									
1	V	Hz	A	kW	cosφ	1/min	I <sub>A</sub> /I <sub>N</sub>	T <sub>E</sub> s	Certif.No	IP
4	400 Δ	50	540	315	0.87	1488				55
12	690 Y		315							
7	Rotor SQU.CAGE KL 13 EN/IEC 60034-1 Gew/Wt 1.5 t									
5	380..420VΔ, 560..530A 660..725V Y, 325..305A 50Hz									
16	N <sub>MAX</sub> =3000 1/MIN									
17	S.F. 1.10									
18	MADE IN GERMANY D-90441 Nürnberg									

1 Motor type: 3-phase LV motor	9 Motor weight [kg]
2 Type of construction	10 Temperature class
3 Degree of protection	11 Rated speed [rpm]
4 Rated voltage [V] and circuit	12 Rated frequency [Hz]
5 Rated current [A]	13 Power factor [cos φ]
6 Rated output [kW]	14 Maximum speed [rpm]
7 Standards and regulations e.g. explosion-proof motors	15 Motor type
8 Serial number	16 Rotor class
	17 Additional details (optional)
	18 Service factor

Example of rating plate for 1LA8

#### Converter-fed operation

The motors are equipped with standard rotors and are suitable for mains-fed or converter-fed operation.

All motors can therefore be operated with a converter, in principle. Special measures are necessary in the case of some motors, especially when separately driven fans are used.

All data are applicable for a 50 Hz sinusoidal supply.

#### Rated voltage

The tolerance for the rated voltage is in accordance with DIN EN 60034-1 in all cases, a rated voltage range is not specified.

#### Motor protection

A motor protection function can be implemented using the  $I^2t$  detection present in the converter software.

If required, more precise motor protection can be afforded by direct temperature measurement using KTY84 sensors, PT 100 resistance thermometers or PTC thermistors in the motor winding. Some converters from Siemens determine the motor temperature using the resistance of the temperature sensor. They can be set to a required temperature for alarm and tripping.

If PT 100 resistance thermometers are ordered for cooling temperature monitoring (order code **A61**) or KTY84 temperature sensors (order code **A23**), the standard thermistors are omitted. A combination of **A12** and **A61** or **A12** and **A23** is possible; additional charge on request.

#### Insulation

The standard insulation of the motors is designed such that converter-fed operation is possible without limitation at voltages  $\leq 500$  V. This also applies for operation with a pulse-controlled AC converter with voltage rise times  $t_s > 0.1 \mu\text{s}$  at the motor terminals.

All motors with voltage codes 4, 5 and 8 must be operated under these preconditions on a converter.

This does not apply to motors with voltages  $> 500$  up to 690 V, which must have special insulation for operation on a pulse-controlled AC converter (SINAMICS, SIMOVERT MASTERDRIVES) without a converter circuit ( $du/dt$  filter or sinusoidal filter), i.e. when 10th position of the Order No. = "M".

**For converter-fed operation with the outputs specified in the catalog, the motors are used according to temperature class 155 (F), i.e. in this case neither a service factor  $> 1$  nor an increased coolant temperature is possible (order codes C11, C12 and C13 cannot be ordered).**

#### Motor connection

When connecting the motors, it is important to consider the restrictions for mains-fed machines as well as the maximum conductor cross-sections permitted for the converter.

#### Ventilation/noise generation

The fan noise can increase at speeds that are higher than the rated speed of self-ventilated motors (this is not the case for forced ventilated motors 1PQ8). To increase motor utilization at low speeds it is recommended that forced ventilated motors are used, e.g. those of series 1PQ8.

In general, for converter-fed operation, the noise level is higher than that specified in the catalog (exception: 1PQ8). The increase depends on the converter type and can lie between 5 and 10 dB(A) depending on the frame size and number of poles for the motor.

#### Mechanical stress and grease lifetime

When motors are operated at speeds above the rated speed, the running smoothness and the bearings are subjected to greater mechanical stress. This reduces the grease lifetime and the bearing lifetime. More detailed information on request.

#### Bearings

To prevent damage being caused as a result of bearing currents, insulated bearings are used at the non-drive-end of 1LA8, 1LL8 and 1PQ8 motors for converter-fed operation in the standard version (this can be recognized when 9th position of Order No. = "P").

When operating multiphase induction machines on a converter, an electrical bearing stress results from a capacitive induced voltage via the bearing lubricating film, depending on the principle being used. The physical cause of this is the common-mode voltage at the converter output that is inherent in the control method for a converter: the sum of the three-phase voltages is – in contrast to straightforward mains-fed operation – not equal to zero at every point in time. The high-frequency, pulse-shaped common-mode voltage brings about a residual current, which closes back to the converter's DC link via the machine's internal capacitances, the machine housing and the earthing circuit. The machine's internal capacitances include the main insulation winding capacitance, the geometric capacitance between the rotor and stator, the lubricating film capacitance and the capacitance of any bearing insulation that may be present. The level of the currents due to the internal capacitances is proportional to the gradients, i.e. the voltage variation of the DC voltage ( $i(t) = C \cdot du/dt$ ).

# IEC Squirrel-Cage Motors

## Non-standard motors frame size 315 and above

### Orientation

#### Technical specifications (continued)

In order to apply currents to the motor which are sinusoidal as far as possible (smooth running, oscillation torques, stray losses), a high clock frequency is required for the converter's output voltage. The related (very steep) switching edges of the converter output voltage (and also, therefore, of the common-mode voltage) cause correspondingly high capacitive currents and voltages on the machine's internal capacitances.

The voltage that is injected capacitively across the bearing can result, in the worst case, in stochastic arcing through the lubrication film of the bearing and prematurely age or damage the bearing. (The current pulses caused by arcing in the lubrication film are known as EDM currents (Electrostatic Discharge Machining) in the technical literature.)

This physical effect, which occurs in isolated cases, has mostly been observed in connection with larger motors.

EMC-compliant installation of the drive system is a basic prerequisite for preventing premature bearing damage as a result of bearing currents.

The most important measures for reducing bearing currents:

- Insulated motor bearings at the non-drive-end NDE (BS) (standard for 1LA8, 1LL8 and 1PQ8 for converter-fed operation)
- Use of cables with a symmetrical cable cross-section:

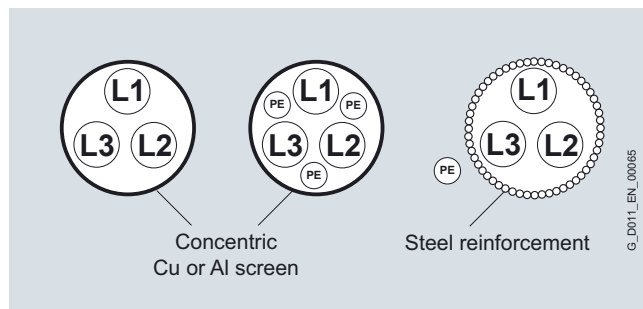

- Preference given to a supply with insulated neutral point (IT system)
- Use of earthing cables with low impedance in a large frequency range (DC up to approximately 70 MHz): for example, plaited copper ribbon cables, HF litz wires
- Separate HF equipotential-bonding cable between motor frame and driven machine
- Separate HF equipotential-bonding cable between motor housing and converter PE busbar
- 360° HF contacting of the cable shield on the motor frame and the converter PE busbar. This can be achieved using EMC screwed glands on the motor end and EMC shield clips on the converter end, for example.
- Using motor reactors at the converter
- Common-mode filters at the converter output

#### Thermal torque limits

Guide values for the maximum load torques at various speeds can be obtained from the diagrams below.

In the case of self-ventilated motors, such as series 1LA8 and 1LL8, the thermally permissible load torques are reduced for continuous operation for speeds below the rated speed. This must be taken into account in those applications in particular that are not subjected to a load torque that is dependent on the square of the speed. Also in the case of forced-air cooled motors of series 1PQ8, the maximum load torques are reduced slightly for high speed ranges.

When motors are operated at speeds above their rated speed (operation in the field-weakening range), the maximum load torque is also reduced.

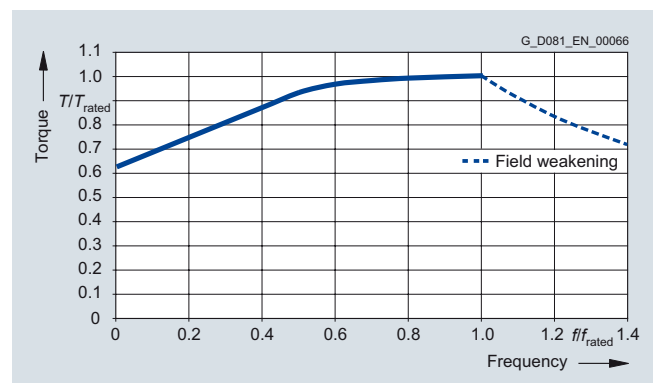

Thermal torque limit characteristic 1LA8

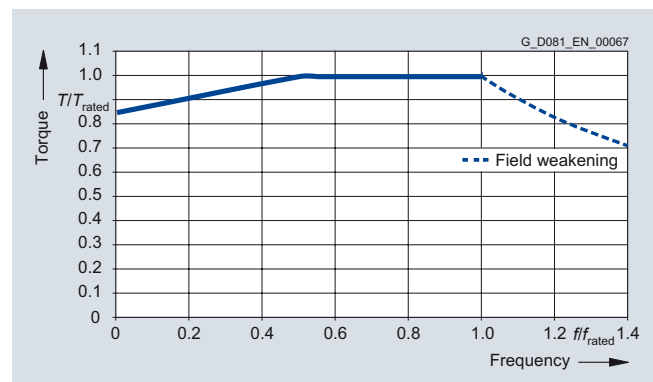

Thermal torque limit characteristic 1PQ8

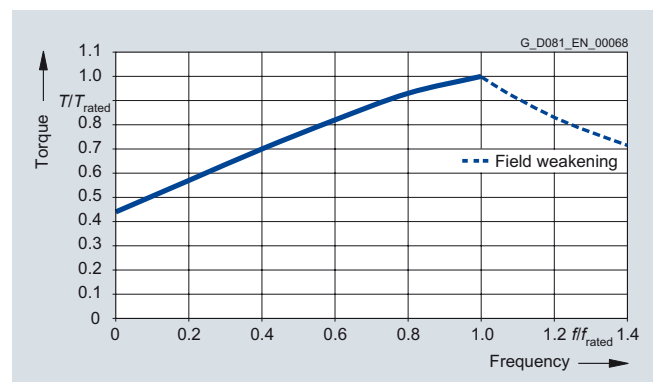

Thermal torque limit characteristic 1LL8

# IEC Squirrel-Cage Motors

## Non-standard motors frame size 315 and above

Orientation

### Technical specifications (continued)

#### Technical explanations regarding torque and determination of the start-up time for mains-fed operation

Torque characteristics – Torque characteristics for special drives

#### Torque characteristics

The torque generated on the shaft of a three-phase motor in the torque range of  $n = 0$  to  $n = n_s$  has a very varying magnitude. The characteristic curve of the torque as a function of the speed of a three-phase motor with torque class (CL) of a squirrel-cage rotor shows the following diagram.

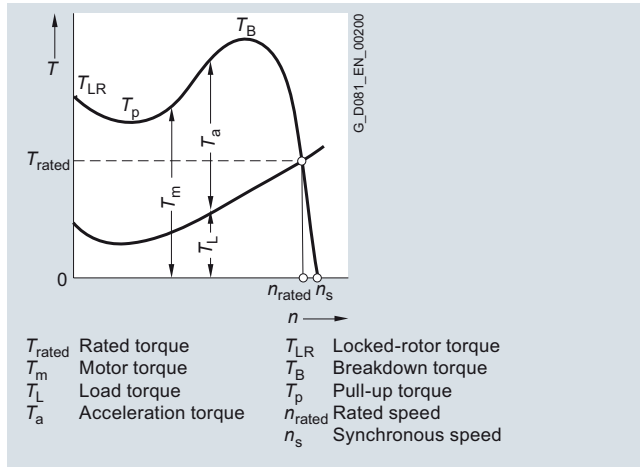

The values for locked-rotor torque and breakdown torque as well as for locked-rotor current of a specific motor can be taken from the selection and ordering data.

The limit for the mechanical overload capability is the breakdown torque. According to IEC/EN 60034-1, asynchronous motors at rated voltage and rated frequency must withstand up to 1.6 times the rated torque for 15 s. The pull-up torque of asynchronous motors at rated voltage must - if not specified otherwise - have at least the values stated in the following rated torque.

For three-phase motors without pole-change with a rated output equal to or greater than 100 kW:

0.3 times rated torque and at least 0.5 times locked-rotor torque

According to IEC/EN 60034-1, the following tolerances are permitted:

- for the locked-rotor torque of –15 to 25 % of the total locked-rotor torque
- for the locked-rotor current up to 20 % of the stated locked-rotor current without lower limit
- for the breakdown torque up to –10 % of the stated breakdown torque
- for the pull-up torque –15 % of the guaranteed value.

Under observance of these tolerances, the locked-rotor torque must be sufficiently higher than the break loose torque of the driven machine and the motor torque during start-up up to reaching the operating speed must always be higher than the load torque.

In the case of squirrel-cage motors, the locked-rotor torque and breakdown torque are listed in the selection and ordering data as multiples of the rated torque. The normal practice is to start squirrel-cage motors directly online. The torque class indicates that with direct online starting, even if there is a 5 % undervoltage, it is possible to start up the motor against a load torque of:

- 130 % (for CL 13),
- 100 % (for CL 10),
- 70 % (for CL 7),
- 50 % (for CL 5)

of the rated torque.

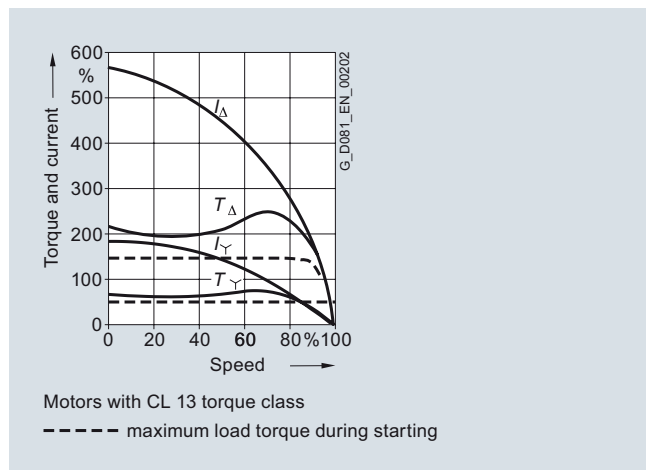
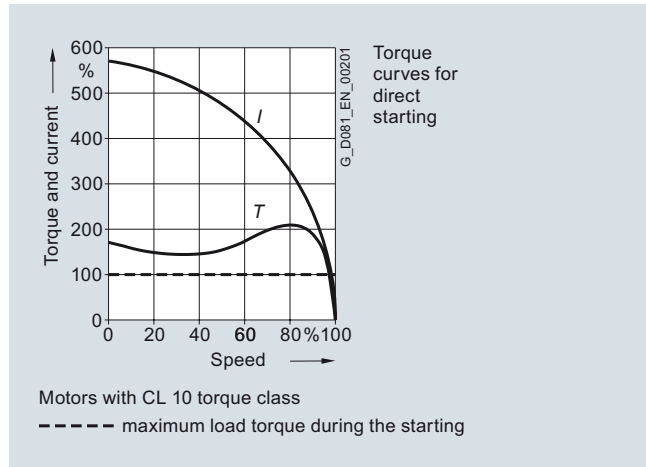

The rated torque can be calculated as follows:

$$T_{rated} = 9.55 \cdot P_{rated} \cdot \frac{1000}{n_{rated}}$$

$T_{rated}$  Rated torque in Nm  
 $n_{rated}$  Rated speed in rpm  
 $P_{rated}$  Rated output in kW

The rated speed of the motor differentiates itself from the synchronous speed by the slip  $s_{rated}$ :

It is:

$$s_{rated} = \frac{n_s - n_{rated}}{n_s} \cdot 100$$

$s_{rated}$  Slip in %  
 $n_s$  Synchronous speed in rpm  
 $n_{rated}$  Rated speed in rpm

#### Determination of the start-up time

##### Calculation of the start-up time for direct online starting

The start-up time from  $n = 0$  to  $n = n_{op}$  can be approximately determined using the average acceleration torque.

$$t_{st} = \frac{\sum J \cdot n_{op}}{9.55 \cdot T_{aav}}$$

$t_{st}$  Start-up time in s  
 $J$  Total moment of inertia in  $\text{kgm}^2$   
 $n_{op}$  Operating speed in rpm  
 $T_{aav}$  Average acceleration torque in Nm

# IEC Squirrel-Cage Motors

## Non-standard motors frame size 315 and above

### Orientation

#### Technical specifications (continued)

The total moment of inertia is made up of the motor moment of inertia plus the moment of inertia of the driven machine and the coupling or pulleys and is converted to the speed of the motor shaft.

Limit values for the start-up curve of three-phase motors with squirrel-cage rotor for voltages up to and including 690 V are defined in EC/EN 60034.

If no sound start-up is possible due to a high moment of inertia and/or a high load torque, a larger motor or a three-phase motor with SINAMICS frequency converter can be selected for N-compact motors.

A mechanical solution for coping with the heavy starting is the employment of a starting coupling, whose application is limited by its capability to absorb heat.

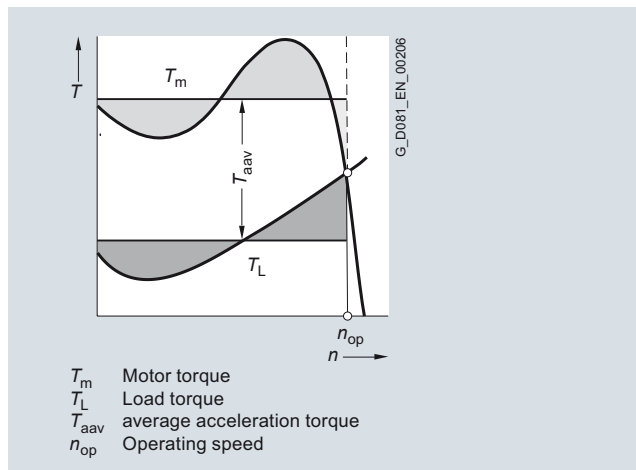

Determination of the average acceleration torque

#### Start-up for three-phase motors with squirrel-cage rotor

The normal practice is to start squirrel-cage motors directly on-line.

- It must be observed that the torque and speed characteristics for a specific motor are predetermined - independently of the heaviness of the start-up. Star delta start-up must be realized for motors with squirrel-cage rotor if small locked-rotor currents (e.g. in the supply conditions of the electric power company) or a particularly low start-up torque (soft starting) are required. Locked-rotor torque, breakdown torque and all other torque values as well as the locked-rotor current are 25 to 30 % of the values at direct online starting.
- The motor torque must be sufficiently higher than the load torque during the start-up in the Y-stage. The change from star to delta must not occur before approximating the operating speed.

The adjoining diagram shows a case in which the star delta start-up is not appropriate because the too elevated load torque causes the early change which in turn causes a high torque and current surge that renders the star-delta starting ineffective.

The torque characteristics can be approximately reduced by the square of the voltage and the current characteristics linearly with the voltage by reducing the voltage at the motor terminals with the help of a starting transformer or starting resistors.

A starting with rated current is possible on the converter.

Soft starting for motors with squirrel-cage rotor can also be realized using the stator-resistance starting circuit (a resistor is engaged in one phase during the start-up). The locked-rotor torque can be arbitrarily reduced with the help of this circuit. The locked-rotor current without a resistor or reactor is a bit higher in both phases than for direct online starting.

The starting can be facilitated using the electronic motor starter "SIKOSTART", that limits the torque and the current during starting.

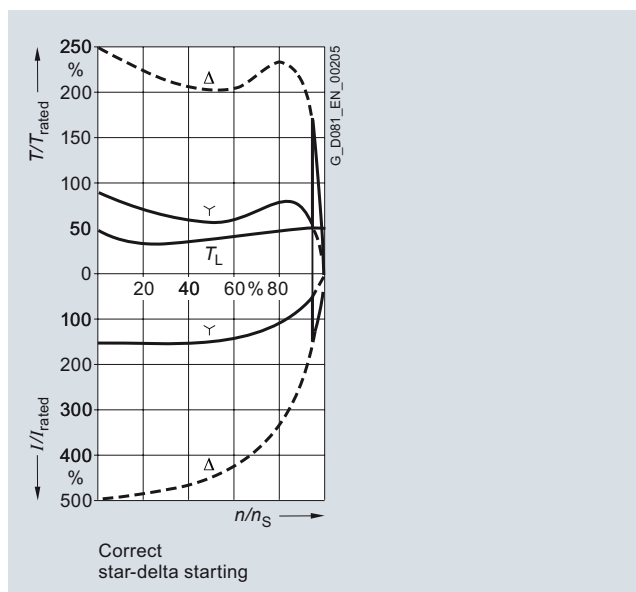
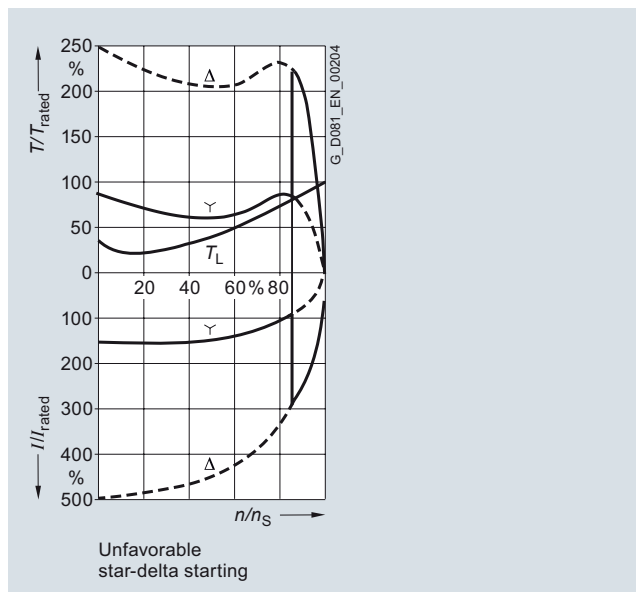

# IEC Squirrel-Cage Motors

## Non-standard motors frame size 315 and above

Orientation

### Technical specifications (continued)

The following has to be provided in case of requests regarding start-ups:

- 1<sup>st</sup> Required output and rated speed of the driven machine
- 2<sup>nd</sup> Planned motor speed
- 3<sup>rd</sup> Load torque of the driven machine, depending on the speed of the driven machine or the motor speed
- 4<sup>th</sup> Total external moments of inertia and rated speed of the driven machine or with regard to the motor speed
- 5<sup>th</sup> Number of starts within a particular time frame and duty cycle or
- 6<sup>th</sup> Characteristics and number of operating cycles within a particular time frame (method of braking)

### Start-up times and moments of inertia for 1LA8 motors for mains-fed operation

#### Default values

The values in the following table are only valid for 1LA8 motors for mains-fed operation (Pages 3/14 to 3/17) and apply for a continuous heating of 90 % of the rated output at 50 Hz ( $0.9 \times P_{\text{rated}}$ ). The admissible moments of inertia must be reduced again by 20 % at 60 Hz. The moment of inertia  $J_{\text{adm}}$  in the tables is the moment of inertia which the driven machine is allowed to have as a maximum in order to start the motor. For this purpose has the moment of inertia already been considered in the selection and ordering data, Pages 3/15 to 3/17.

Frame size	Order No.	Locking of brake		Admissible moment of inertia and start-up times when starting the motor			
		cold	warm	1x cold		1x warm	
		Braking time	Braking time	Moment of inertia	Start-up time	Moment of inertia	Start-up time
FS		$t_{\text{Br}}$ s	$t_{\text{Br}}$ s	$J_{\text{adm}}$ kgm <sup>2</sup>	$t_{\text{st}}$ s	$J_{\text{adm}}$ kgm <sup>2</sup>	$t_{\text{st}}$ s
<b>Self-ventilated motors for mains-fed operation cast-iron series 1LA8 – 2-pole, 3000 rpm at 50 Hz</b>							
315	1LA8 315-2AC□□	18	10	125	33.9	48	13.0
315	1LA8 317-2AC□□	17.5	10	140	33.2	58	13.4
355	1LA8 353-2AC□□	18	9	175	41.4	33	7.8
355	1LA8 355-2AC□□	20	10	190	45.8	40	9.7
355	1LA8 357-2AC□□	15	7.5	180	30.0	40	6.7
400	1LA8 403-2AC□□	22	13	245	40.2	95	15.7
400	1LA8 405-2AC□□	19	11	255	37.2	90	13.1
400	1LA8 407-2AC□□	17	9.5	300	34.9	85	9.9
450	1LA8 453-2AE□□	21.5	15	178	31.3	83	14.6
450	1LA8 455-2AE□□	20.5	14	190	30.2	90	14.3
450	1LA8 457-2AE□□	19	13	200	28.2	95	13.4
<b>Self-ventilated motors for mains-fed operation cast-iron series 1LA8 – 4-pole, 1500 rpm at 50 Hz</b>							
315	1LA8 315-4AB□□	22	13	590	36.9	350	21.9
315	1LA8 317-4AB□□	19	11	730	32.3	425	18.8
355	1LA8 353-4AB□□	20	11	1000	45.7	270	12.4
355	1LA8 355-4AB□□	18	10	1020	39.6	280	10.9
355	1LA8 357-4AB□□	19	10.5	1370	41.9	370	11.3
400	1LA8 403-4AB□□	20.5	11.5	1420	46.2	430	14.0
400	1LA8 405-4AB□□	20	11	1600	44.5	480	13.3
400	1LA8 407-4AB□□	19	10.5	1750	43.6	525	13.1
450	1LA8 453-4CE□□	17.5	10	950	23.7	300	7.5
450	1LA8 455-4AC□□	18.5	10.5	1200	26.8	370	8.3
450	1LA8 457-4AC□□	17	9	1160	22.3	380	7.3

# IEC Squirrel-Cage Motors

## Non-standard motors frame size 315 and above

### Orientation

#### Technical specifications (continued)

Frame size	Order No.	Locking of brake		Admissible moment of inertia and start-up times when starting the motor			
		cold	warm	1x cold		1x warm	
		Braking time	Braking time	Moment of inertia	Start-up time	Moment of inertia	Start-up time
FS		$t_{Br}$ s	$t_{Br}$ s	$J_{adm}$ kgm <sup>2</sup>	$t_{st}$ s	$J_{adm}$ kgm <sup>2</sup>	$t_{st}$ s
<b>Self-ventilated motors for mains-fed operation cast-iron series 1LA8 – 6-pole, 1000 rpm at 50 Hz</b>							
315	<b>1LA8 315-6AB□□</b>	33	18	1900	57.4	830	25.1
315	<b>1LA8 317-6AB□□</b>	31	15.5	2300	55.6	1000	24.2
355	<b>1LA8 355-6AB□□</b>	40	22	2950	62.2	1350	28.5
355	<b>1LA8 357-6AB□□</b>	40	22	3950	62.5	1800	28.5
400	<b>1LA8 403-6AB□□</b>	34	18.4	3450	51.1	850	12.6
400	<b>1LA8 405-6AB□□</b>	32	17.5	3500	43.3	900	11.1
400	<b>1LA8 407-6AB□□</b>	24	12	2200	25.6	740	8.6
450	<b>1LA8 453-6AB□□</b>	16	7	1400	15.5	560	6.2
450	<b>1LA8 455-6AB□□</b>	19	8.5	1700	18.1	670	7.1
450	<b>1LA8 457-6AB□□</b>	16	7	1800	15.9	720	6.4
<b>Self-ventilated motors for mains-fed operation cast-iron series 1LA8 – 8-pole, 750 rpm at 50 Hz</b>							
315	<b>1LA8 315-8AB□□</b>	40	22	4800	109.5	1950	44.5
315	<b>1LA8 317-8AB□□</b>	42	23	6800	125.9	2500	46.3
355	<b>1LA8 355-8AB□□</b>	41	22.5	6200	89.6	3100	44.8
355	<b>1LA8 357-8AB□□</b>	40	22	7600	88.7	3800	44.3
400	<b>1LA8 403-8AB□□</b>	55	30	9700	107.5	4400	48.8
400	<b>1LA8 405-8AB□□</b>	54	29.5	11000	102.9	5400	50.5
400	<b>1LA8 407-8AB□□</b>	52	28.5	11200	95.4	5400	46.0
450	<b>1LA8 453-8AB□□</b>	44	25	9800	78.8	2900	23.3
450	<b>1LA8 455-8AB□□</b>	42	23	10500	71.4	3000	20.4
450	<b>1LA8 457-8AB□□</b>	44	25	12400	78.1	3700	23.3



# IEC Squirrel-Cage Motors

## Non-standard motors frame size 315 and above

Orientation

### Selection and ordering data

*Preliminary selection of the motor according to motor type/series, speed or number of poles, frame size, rated output, rated torque, rated speed and rated current*

Self-ventilated motors for mains-fed operation (IP55 degree of protection)

Speed	Frame size	Rated output	Rated speed	Rated torque	Rated current at 400 V	Detailed selection and ordering data Page
rpm		kW	rpm	Nm	A	
<b>Cast-iron series 1LA8</b>						
<b>3000, 2-pole</b>	<b>315 ... 450</b>	250 ... 1000	2979 ... 2986	801 ... 3200	415 ... 1020	<b>3/14 ... 3/15</b>
<b>1500, 4-pole</b>	<b>315 ... 450</b>	250 ... 1000	1488 ... 1492	1600 ... 6400	430 ... 1060	<b>3/14 ... 3/15</b>
<b>1000, 6-pole</b>	<b>315 ... 450</b>	200 ... 800	988 ... 993	1930 ... 7690	345 ... 1100	<b>3/16 ... 3/17</b>
<b>750, 8-pole</b>	<b>315 ... 450</b>	160 ... 630	739 ... 744	2070 ... 8090	295 ... 1160	<b>3/16 ... 3/17</b>

Self-ventilated motors for converter-fed operation (IP55 degree of protection)

Speed	Frame size	Rated output	Rated speed	Rated torque	Rated current at 400 V	Detailed selection and ordering data Page
rpm		kW	rpm	Nm	A	
<b>Cast-iron series 1LA8 with standard insulation ≤500 V</b>						
<b>3000, 2-pole</b>	<b>315 ... 450</b>	250 ... 1000	2979 ... 2986	801 ... 3200	415 ... 1020	<b>3/18 ... 3/19</b>
<b>1500, 4-pole</b>	<b>315 ... 450</b>	250 ... 1000	1488 ... 1492	1600 ... 6400	430 ... 1060	<b>3/18 ... 3/19</b>
<b>1000, 6-pole</b>	<b>315 ... 450</b>	200 ... 800	988 ... 993	1930 ... 7690	345 ... 1100	<b>3/20 ... 3/21</b>
<b>750, 8-pole</b>	<b>315 ... 450</b>	160 ... 630	739 ... 744	2070 ... 8090	295 ... 1160	<b>3/20 ... 3/21</b>

Speed	Frame size	Rated output	Rated speed	Rated torque	Rated current at 690 V	Detailed selection and ordering data Page
rpm		kW	rpm	Nm	A	
<b>Cast-iron series 1LA8 with special insulation &gt;500 to 690 V</b>						
<b>3000, 2-pole</b>	<b>315 ... 450</b>	240 ... 970	2978 ... 2987	770 ... 3101	730 ... 900	<b>3/22 ... 3/23</b>
<b>1500, 4-pole</b>	<b>315 ... 450</b>	235 ... 980	1485 ... 1492	1511 ... 6273	235 ... 950	<b>3/22 ... 3/23</b>
<b>1000, 6-pole</b>	<b>315 ... 450</b>	190 ... 780	990 ... 993	1833 ... 7502	196 ... 790	<b>3/24 ... 3/25</b>
<b>750, 8-pole</b>	<b>315 ... 450</b>	145 ... 600	740 ... 745	1871 ... 7691	162 ... 660	<b>3/24 ... 3/25</b>

Forced-air cooled motors with mounted separately driven fan for converter-fed operation (IP55 degree of protection)

Speed	Frame size	Rated output	Rated speed	Rated torque	Rated current at 400 V	Detailed selection and ordering data Page
rpm		kW	rpm	Nm	A	
<b>Cast-iron series 1PQ8 with standard insulation ≤500 V</b>						
<b>3000, 2-pole</b>	<b>315 ... 450</b>	250 ... 1000	2979 ... 2986	801 ... 3200	415 ... 1020	<b>3/26 ... 3/27</b>
<b>1500, 4-pole</b>	<b>315 ... 450</b>	250 ... 1000	1488 ... 1492	1600 ... 6400	430 ... 1060	<b>3/26 ... 3/27</b>
<b>1000, 6-pole</b>	<b>315 ... 450</b>	200 ... 800	988 ... 993	1930 ... 7690	345 ... 1100	<b>3/28 ... 3/29</b>
<b>750, 8-pole</b>	<b>315 ... 450</b>	160 ... 630	739 ... 744	2070 ... 8090	295 ... 1160	<b>3/28 ... 3/29</b>

Speed	Frame size	Rated output	Rated speed	Rated torque	Rated current at 690 V	Detailed selection and ordering data Page
rpm		kW	rpm	Nm	A	
<b>Cast-iron series 1PQ8 with special insulation &gt;500 to 690 V</b>						
<b>3000, 2-pole</b>	<b>315 ... 450</b>	240 ... 970	2978 ... 2987	770 ... 3101	730 ... 900	<b>3/30 ... 3/31</b>
<b>1500, 4-pole</b>	<b>315 ... 450</b>	235 ... 980	1485 ... 1492	1511 ... 6273	235 ... 950	<b>3/30 ... 3/31</b>
<b>1000, 6-pole</b>	<b>315 ... 450</b>	190 ... 780	990 ... 993	1833 ... 7502	196 ... 790	<b>3/32 ... 3/33</b>
<b>750, 8-pole</b>	<b>315 ... 450</b>	145 ... 600	740 ... 745	1871 ... 7691	162 ... 660	<b>3/32 ... 3/33</b>

# IEC Squirrel-Cage Motors

## Non-standard motors frame size 315 and above

### Orientation

#### Selection and ordering data (continued)

Self-ventilated motors with through-ventilation for mains-fed operation (IP23 degree of protection)

Speed	Frame size	Rated output	Rated speed	Rated torque	Rated current at 400 V	Detailed selection and ordering data Page
rpm		kW	rpm	Nm	A	
<b>Cast-iron series 1LL8</b>						
<b>3000, 2-pole</b>	<b>315 ... 450</b>	315 ... 1250	2974 ... 2986	1010 ... 4000	510 ... 1300	<b>3/34 ... 3/35</b>
<b>1500, 4-pole</b>	<b>315 ... 450</b>	315 ... 1250	1483 ... 1490	2030 ... 8010	540 ... 1360	<b>3/34 ... 3/35</b>
<b>1000, 6-pole</b>	<b>315 ... 450</b>	250 ... 1000	988 ... 993	2420 ... 9620	430 ... 1380	<b>3/36 ... 3/37</b>
<b>750, 8-pole</b>	<b>315 ... 450</b>	200 ... 800	738 ... 743	2590 ... 10300	370 ... 1440	<b>3/36 ... 3/37</b>

Self-ventilated motors with through-ventilation for converter-fed operation (IP23 degree of protection)

Speed	Frame size	Rated output	Rated speed	Rated torque	Rated current at 400 V	Detailed selection and ordering data Page
rpm		kW	rpm	Nm	A	
<b>Cast-iron series 1LL8 with standard insulation ≤500 V</b>						
<b>3000, 2-pole</b>	<b>315 ... 450</b>	315 ... 1250	2974 ... 2986	1010 ... 4000	510 ... 1300	<b>3/38 ... 3/39</b>
<b>1500, 4-pole</b>	<b>315 ... 450</b>	315 ... 1250	1483 ... 1490	2030 ... 8010	540 ... 1360	<b>3/38 ... 3/39</b>
<b>1000, 6-pole</b>	<b>315 ... 450</b>	250 ... 1000	988 ... 993	2420 ... 9620	430 ... 1380	<b>3/40 ... 3/41</b>
<b>750, 8-pole</b>	<b>315 ... 450</b>	200 ... 800	738 ... 743	2590 ... 10300	370 ... 1440	<b>3/40 ... 3/41</b>

Speed	Frame size	Rated output	Rated speed	Rated torque	Rated current at 690 V	Detailed selection and ordering data Page
rpm		kW	rpm	Nm	A	
<b>Cast-iron series 1LL8 with special insulation &gt;500 to 690 V</b>						
<b>3000, 2-pole</b>	<b>315 ... 450</b>	300 ... 1210	2977 ... 2988	962 ... 3871	290 ... 800	<b>3/42 ... 3/43</b>
<b>1500, 4-pole</b>	<b>315 ... 450</b>	295 ... 1225	1485 ... 1493	1897 ... 7846	300 ... 880	<b>3/42 ... 3/43</b>
<b>1000, 6-pole</b>	<b>315 ... 450</b>	235 ... 975	990 ... 994	2267 ... 9377	240 ... 850	<b>3/44 ... 3/45</b>
<b>750, 8-pole</b>	<b>315 ... 450</b>	180 ... 760	738 ... 742	2329 ... 9782	198 ... 800	<b>3/44 ... 3/45</b>

# IEC Squirrel-Cage Motors

## Non-standard motors frame size 315 and above

Orientation

### More information

#### *Standardline*

4-pole 1LA8 motors are available with a reduced range of options up to an output of 500 kW in the *Standardline*.

The benefit to the customer:

- Much shorter delivery time
- Products in the *Standardline* can be configured with a variety of options so as to ensure a high degree of flexibility.

#### Application:

*Standardline* low-voltage motors are optimised for applications in pump, fan and compressor drives.

For the low-voltage motors, this is particularly true for complete, coordinated drive systems comprising the motor and a SINAMICS G150 frequency converter.

*Standardline* motors can be ordered with the order code **B20**.

#### Scope of the *Standardline*:

- 4-pole version
- Power range 250 to 500 kW
- Types 1LA8 315, 1LA8 317, 1LA8 353, 1LA8 355 and 1LA8 357
- Type of construction code **0** (IM B3)
- For mains-fed operation: Voltage code **6** (400 VΔ/690 VY) or **5** (500 VΔ)
- For converter-fed operation: Voltage code **4** (400 VΔ), **8** (400 VΔ/690 VY) or **5** (500 VΔ)
- Can be ordered for converter-fed operation, but not in the 690 V version
- Possible order codes: **A23, A61, A72, G50, H70, H73, K09, K10, K45, K46, K57, K83, K84, K85, L00, L97, M58** (only frame size 315), **M88** and **Y53**

For more information, see Catalog D 86.1 *Standardline*.

For more information, please contact your local Siemens contact – see “Siemens contacts worldwide” in the Appendix.

# IEC Squirrel-Cage Motors

## Non-standard motors frame size 315 and above

Self-ventilated motors for mains-fed operation  
Cast-iron series 1LA8

### Selection and ordering data

Rated output at		Frame size	Operating values at rated output							Order No.	Price	Weight of IM B3 type of construction, approx.
50 Hz	60 Hz		Rated speed at 50 Hz	Rated torque at 50 Hz	Efficiency at 50 Hz 4/4-load	Efficiency at 50 Hz 3/4-load	Power factor at 50 Hz 4/4-load	Rated current at 50 Hz 400 V	Rated current at 50 Hz 690 V			
$P_{\text{rated}}$ kW	$P_{\text{rated}}$ kW	FS	$n_{\text{rated}}$ rpm	$T_{\text{rated}}$ Nm	$\eta_{\text{rated}}$ %	$\eta_{\text{rated}}$ %	$\cos\phi_{\text{rated}}$	$I_{\text{rated}}$ A	$I_{\text{rated}}$ A	For Order No. supplements for voltage and type of construction, see table below	$m$ kg	
<b>2-pole, 3000 rpm at 50 Hz, 3600 rpm at 60 Hz, temperature class 155 (F), used acc. to temperature class 130 (B), IP55 degree of protection</b>												
250	280	315	2979	801	96.2	96.2	0.90	415	240	1LA8 315-2AC□□	1300	
315	353	315	2979	1010	96.5	96.5	0.91	520	300	1LA8 317-2AC□□	1500	
355	398	355	2980	1140	96.5	96.5	0.90	590	340	1LA8 353-2AC□□	1900	
400	448	355	2980	1280	96.7	96.7	0.91	660	380	1LA8 355-2AC□□	2000	
500	560	355	2982	1600	97.1	97.1	0.91	820	475	1LA8 357-2AC□□	2200	
560	616	400	2985	1790	97.1	97.1	0.91	910	530	1LA8 403-2AC□□	2800	
630	693	400	2985	2020	97.1	97.1	0.91	1020	600	1LA8 405-2AC□□	3000	
710	781	400	2985	2270	97.3	97.3	0.91	–	670 <sup>1)</sup>	1LA8 407-2AC□□	3200	
800	–	450	2986	2560	97.2	97.2	0.91	–	760	1LA8 453-2AE□□	4000	
900	–	450	2986	2880	97.3	97.3	0.92	–	840	1LA8 455-2AE□□	4200	
1000	–	450	2986	3200	97.4	97.4	0.93	–	920	1LA8 457-2AE□□	4400	
<b>4-pole, 1500 rpm at 50 Hz, 1800 rpm at 60 Hz, temperature class 155 (F), used acc. to temperature class 130 (B), IP55 degree of protection</b>												
250	288	315	1488	1600	96.0	96.0	0.87	430	250 <sup>2)</sup>	1LA8 315-4AB□□	1300	
315	362	315	1488	2020	96.2	96.2	0.87	540	315 <sup>2)</sup>	1LA8 317-4AB□□	1500	
355	408	355	1488	2280	96.3	96.3	0.87	610	355 <sup>2)</sup>	1LA8 353-4AB□□	1900	
400	460	355	1488	2570	96.4	96.4	0.87	690	400 <sup>2)</sup>	1LA8 355-4AB□□	2000	
500	575	355	1488	3210	96.7	96.7	0.88	850	490 <sup>2)</sup>	1LA8 357-4AB□□	2200	
560	644	400	1492	3580	96.7	96.7	0.88	950	550	1LA8 403-4AB□□	2800	
630	725	400	1492	4030	96.9	96.9	0.88	1060	620	1LA8 405-4AB□□	3000	
710	817	400	1492	4540	97.0	97.0	0.89	–	690 <sup>1)</sup>	1LA8 407-4AB□□	3200	
800	920	450	1492	5120	97.0	97.0	0.88	–	780 <sup>1)</sup>	1LA8 453-4AC□□	4000	
900	1040	450	1492	5760	97.1	97.1	0.88	–	880	1LA8 455-4AC□□	4200	
1000	1150	450	1492	6400	97.1	97.1	0.89	–	970	1LA8 457-4AC□□	4400	

Up to frame size 355, a service factor of 1.1 is stamped, above this 1.05.

### Order No. supplements

Motor type	Penultimate position: Voltage code				Final position: Type of construction code			
	400 VΔ/690 VY	500 VΔ	690 VΔ	60 Hz 460 VΔ (for rated output at 60 Hz, see above)	Without flange IM B3	With flange IM V1 without protective cover <sup>3)</sup>	IM V1 with protective cover <sup>4)</sup>	IM B35
	<b>6</b>	<b>5</b>	<b>0</b>	<b>9 L2F</b>	<b>0</b>	<b>8</b>	<b>4</b>	<b>6</b>
1LA8 315-... □□ to 1LA8 405-... □□	□	○	– <sup>5)</sup>	○	□	✓ <sup>6)</sup>	✓ <sup>6)</sup>	✓
1LA8 407-... □□ to 1LA8 457-... □□	–	○	□	O. R.	□	✓ <sup>6)</sup>	✓ <sup>6)</sup>	✓ <sup>7)</sup>

- Standard version
- Without additional charge
- ✓ With additional charge
- O. R. Possible on request
- Not possible

Order other voltages with voltage code **9** in the penultimate position and the corresponding order code (see "Special versions" in the "Selection and ordering data" under "Voltages").

Voltages or frequencies that are not covered by the predefined options can be ordered with order code **L1Y**. In this case, the output, voltage and frequency must be specified.

<sup>1)</sup> Can also be supplied for 400 VΔ 50 Hz with voltage code "9" and order code **L1Y** (specify output, voltage and frequency).

<sup>2)</sup> **Standardline** for 1LA8 motors is a standardized range in specific versions which can be ordered with the order code **B20**. The delivery time is 4 weeks. Scope of the **Standardline**: 4-pole, types **1LA8 315**, **1LA8 317**, **1LA8 353**, **1LA8 355**, type of construction code **0** (IM B3), voltage code **6** (400 VΔ/690 VY) or **5** (500 VΔ); can be ordered for converter-fed operation, but not in 690 V version; possible order codes: **A23**, **A61**, **A72**, **G50**, **H70**, **H73**, **K09**, **K10**, **K45**, **K46**, **K57**, **K83**, **K84**, **K85**, **L00**, **L97**, **M58** (for frame size 315 only), **M88**, **Y53**.

<sup>3)</sup> For explosion-proof motors, the type of construction IM V1 without protective cover is not possible.

<sup>4)</sup> The "Second shaft extension" option, order code **K16** is not possible.

<sup>5)</sup> As special version with voltage code "9" and order code **L1Y** (specify output, voltage and frequency).

<sup>6)</sup> For 2-pole motors 60 Hz version, not possible for 1LA8 353 to 1LA8 457.

<sup>7)</sup> For 2-pole motors 60 Hz version, not possible for 1LA8 453 to 1LA8 457.

# IEC Squirrel-Cage Motors

## Non-standard motors frame size 315 and above

Self-ventilated motors for mains-fed operation  
Cast-iron series 1LA8

### Selection and ordering data (continued)

Order No.	Locked-rotor torque	Locked-rotor current	Breakdown torque	Torque class	Moment of inertia	Noise at rated output		Mech. limit speed <sup>1)</sup>	Parallel feeders required		
	At 50 Hz and for direct online starting as multiple of rated torque					Measuring surface sound pressure level at 50 Hz	Sound power level at 50 Hz		400 V	500 V	690 V
	$T_{LR}/T_{rated}$	$I_{LR}/I_{rated}$	$T_B/T_{rated}$	CL	$J$ kgm <sup>2</sup>	$L_{pFA}$ dB(A)	$L_{WA}$ dB(A)	$n_{max.}$ rpm			
<b>2-pole, 3000 rpm at 50 Hz, 3600 rpm at 60 Hz, temperature class 155 (F), used acc. to temperature class 130 (B), IP55 degree of protection</b>											
1LA8 315-2AC□□	1.8	7.0	2.8	10	2.7	82 (75) <sup>2)</sup>	97 (90) <sup>2)</sup>	3600			Yes
1LA8 317-2AC□□	1.8	7.0	2.8	10	3.3	82 (75) <sup>2)</sup>	97 (90) <sup>2)</sup>	3600			Yes
1LA8 353-2AC□□	1.7	6.5	2.5	10	4.8	77 <sup>3)</sup>	92 <sup>3)</sup>	3600/3100 <sup>4)</sup>	Yes	Yes	
1LA8 355-2AC□□	1.7	6.5	2.5	10	5.3	77 <sup>3)</sup>	92 <sup>3)</sup>	3600/3100 <sup>4)</sup>	Yes	Yes	
1LA8 357-2AC□□	1.8	6.5	2.6	10	6.4	77 <sup>3)</sup>	92 <sup>3)</sup>	3600/3100 <sup>4)</sup>	Yes		
1LA8 403-2AC□□	1.6	7.0	2.8	10	8.6	79 <sup>3)</sup>	94 <sup>3)</sup>	3600/3100 <sup>4)</sup>	Yes		
1LA8 405-2AC□□	1.6	7.0	2.8	10	9.6	79 <sup>3)</sup>	94 <sup>3)</sup>	3600/3100 <sup>4)</sup>	Yes	Yes	
1LA8 407-2AC□□	1.7	7.0	2.8	10	11	79 <sup>3)</sup>	94 <sup>3)</sup>	3600/3100 <sup>4)</sup>			Yes
1LA8 453-2AE□□	0.9	7.0	3.0	5	19	81 <sup>3)</sup>	96 <sup>3)</sup>	3000			Yes
1LA8 455-2AE□□	0.9	7.0	2.8	5	21	81 <sup>3)</sup>	96 <sup>3)</sup>	3000			Yes Yes
1LA8 457-2AE□□	0.9	7.0	2.7	5	23	81 <sup>3)</sup>	96 <sup>3)</sup>	3000			Yes Yes
<b>4-pole, 1500 rpm at 50 Hz, 1800 rpm at 60 Hz, temperature class 155 (F), used acc. to temperature class 130 (B), IP55 degree of protection</b>											
1LA8 315-4AB□□	1.9	6.5	2.8	13	3.6	73	87	3000 (2650)			Yes
1LA8 317-4AB□□	2.0	6.8	2.8	13	4.4	73	87	3000 (2650)			Yes
1LA8 353-4AB□□	2.1	6.5	2.6	13	6.1	75	90	2500 (2350)	Yes	Yes	
1LA8 355-4AB□□	2.1	6.5	2.6	13	6.8	75	90	2500 (2350)	Yes	Yes	
1LA8 357-4AB□□	2.1	6.5	2.4	13	8.5	75	90	2500 (2350)	Yes		
1LA8 403-4AB□□	1.9	6.5	2.7	13	13	78	93	2200 (2100)/2100 <sup>4)</sup>	Yes		
1LA8 405-4AB□□	1.9	6.8	2.7	13	14	78	93	2200 (2100)/2100 <sup>4)</sup>	Yes	Yes	
1LA8 407-4AB□□	1.9	6.8	2.7	13	16	78	93	2200 (2100)/2100 <sup>4)</sup>			Yes
1LA8 453-4AC□□	1.6	7.0	2.6	10	23	81	96	2100 (1900)/1800 <sup>4)</sup>			Yes
1LA8 455-4AC□□	1.6	7.0	2.6	10	26	81	96	2100 (1900)/1800 <sup>4)</sup>	Yes	Yes	
1LA8 457-4AC□□	1.7	7.0	2.6	10	28	81	96	2100 (1900)/1800 <sup>4)</sup>	Yes	Yes	

Values in brackets apply to the use of motors in hazardous areas.

<sup>1)</sup> Limit speeds for reinforced bearings (order code **K20**) for 4-pole motors on request.  
<sup>2)</sup> Low-noise version, 2-pole, in brackets. To reduce noise, 2-pole motors can be equipped with an axial fan that is only suitable for one direction of rotation. Clockwise rotation order code **K37**, counter-clockwise rotation **K38**.

<sup>3)</sup> In the standard version, the motors already have an axial fan for clockwise rotation. Order code **K37** is not necessary. For counter-clockwise rotation, order code **K38** is necessary.

<sup>4)</sup> For vertical type of construction IM V1.

# IEC Squirrel-Cage Motors

## Non-standard motors frame size 315 and above

Self-ventilated motors for mains-fed operation  
Cast-iron series 1LA8

### Selection and ordering data (continued)

Rated output at		Frame size	Operating values at rated output							Order No.	Price	Weight of IM B3 type of construction, approx.
50 Hz	60 Hz		Rated speed at 50 Hz	Rated torque at 50 Hz	Efficiency at 50 Hz 4/4-load	Efficiency at 50 Hz 3/4-load	Power factor at 50 Hz 4/4-load	Rated current at 50 Hz 400 V	Rated current at 50 Hz 690 V			
$P_{\text{rated}}$ kW	$P_{\text{rated}}$ kW	FS	$n_{\text{rated}}$ rpm	$T_{\text{rated}}$ Nm	$\eta_{\text{rated}}$ %	$\eta_{\text{rated}}$ %	$\cos\phi_{\text{rated}}$	$I_{\text{rated}}$ A	$I_{\text{rated}}$ A	For Order No. supplements for voltage and type of construction, see table below	$m$ kg	
<b>6-pole, 1000 rpm at 50 Hz, 1200 rpm at 60 Hz, temperature class 155 (F), used acc. to temperature class 130 (B), IP55 degree of protection</b>												
200	230	315	988	1930	95.7	95.8	0.86	345	200	1LA8 315-6AB□□	1300	
250	288	315	988	2410	95.9	96.0	0.86	430	250	1LA8 317-6AB□□	1500	
315	362	355	993	3040	96.2	96.2	0.86	540	315	1LA8 355-6AB□□	2000	
400	460	355	993	3850	96.5	96.5	0.86	690	400	1LA8 357-6AB□□	2200	
450	518	400	991	4330	96.5	96.5	0.86	780	455	1LA8 403-6AB□□	2800	
500	575	400	991	4810	96.5	96.5	0.86	860	500	1LA8 405-6AB□□	3000	
560	644	400	991	5390	96.7	96.7	0.86	960	560	1LA8 407-6AB□□	3200	
630	725	450	993	6060	96.8	96.8	0.86	1100	630	1LA8 453-6AB□□	4000	
710	817	450	993	6830	96.8	96.8	0.86	–	710 <sup>1)</sup>	1LA8 455-6AB□□	4200	
800	920	450	993	7690	97.0	97.1	0.86	–	790	1LA8 457-6AB□□	4500	
<b>8-pole, 750 rpm at 50 Hz, 900 rpm at 60 Hz, temperature class 155 (F), used acc. to temperature class 130 (B), IP55 degree of protection</b>												
160	184	315	739	2070	94.9	94.9	0.82	295	172	1LA8 315-8AB□□	1300	
200	230	315	739	2580	95.2	95.2	0.82	370	215	1LA8 317-8AB□□	1500	
250	288	355	741	3220	95.7	95.7	0.82	460	265	1LA8 355-8AB□□	2000	
315	362	355	741	4060	96.0	96.0	0.82	580	335	1LA8 357-8AB□□	2200	
355	408	400	742	4570	96.1	96.1	0.82	650	375	1LA8 403-8AB□□	2800	
400	460	400	742	5150	96.2	96.2	0.82	730	425	1LA8 405-8AB□□	3000	
450	518	400	742	5790	96.3	96.3	0.82	820	475	1LA8 407-8AB□□	3200	
500	575	450	744	6420	96.4	96.4	0.81	920	540	1LA8 453-8AB□□	4000	
560	644	450	744	7190	96.5	96.5	0.81	1040	600	1LA8 455-8AB□□	4200	
630	725	450	744	8090	96.6	96.6	0.81	1160	670	1LA8 457-8AB□□	4500	

Up to frame size 355, a service factor of 1.1 is stamped, above this 1.05.

### Order No. supplements

Motor type	Penultimate position: Voltage code				Final position: Type of construction code			
	400 VΔ/690 VY	500 VΔ	690 VΔ	60 Hz 460 VΔ (for rated output at 60 Hz, see above)	Without flange IM B3	With flange IM V1 without protective cover <sup>2)</sup>	IM V1 with protective cover <sup>3)</sup>	IM B35
	6	5	0	9 L2F	0	8	4	6
<b>6-pole</b>								
1LA8 315-...□□ to 1LA8 453-...□□	□	○	– <sup>4)</sup>	○	□	✓	✓	✓
1LA8 455-...□□ to 1LA8 457-...□□	–	○	□	O. R.	□	✓	✓	✓
<b>8-pole</b>								
1LA8 315-...□□ to 1LA8 457-...□□	□	○	– <sup>4)</sup>	○	□	✓	✓	✓

- Standard version
- Without additional charge
- ✓ With additional charge
- O. R. Possible on request
- Not possible

Order other voltages with voltage code **9** in the penultimate position and the corresponding order code (see "Special versions" in the "Selection and ordering data" under "Voltages").

Voltages or frequencies that are not covered by the predefined options can be ordered with order code **L1Y**. In this case, the output, voltage and frequency must be specified.

<sup>1)</sup> Can also be supplied for 400 VΔ 50 Hz with voltage code "9" and order code **L1Y** (specify output, voltage and frequency).  
<sup>2)</sup> For explosion-proof motors, the type of construction IM V1 without protective cover is not possible.

<sup>3)</sup> The "Second shaft extension" option, order code **K16** is not possible.  
<sup>4)</sup> As special version with voltage code "9" and order code **L1Y** (specify output, voltage and frequency).

# IEC Squirrel-Cage Motors

## Non-standard motors frame size 315 and above

Self-ventilated motors for mains-fed operation  
Cast-iron series 1LA8

### Selection and ordering data (continued)

Order No.	Locked-rotor torque	Locked-rotor current	Breakdown torque	Torque class	Moment of inertia	Noise at rated output		Mech. limit speed <sup>1)</sup>	Parallel feeders required		
	At 50 Hz and for direct online starting as multiple of rated torque					Measuring surface sound pressure level at 50 Hz	Sound power level at 50 Hz		400 V	500 V	690 V
	$T_{LR}/T_{rated}$	$I_{LR}/I_{rated}$	$T_B/T_{rated}$	CL	$J$ kgm <sup>2</sup>	$L_{pFA}$ dB(A)	$L_{WA}$ dB(A)	$n_{max}$ rpm			
<b>6-pole, 1000 rpm at 50 Hz, 1200 rpm at 60 Hz, temperature class 155 (F), used acc. to temperature class 130 (B), IP55 degree of protection</b>											
1LA8 315-6AB□□	2.0	6.3	2.5	13	6.0	68	82	2950 (2350)			
1LA8 317-6AB□□	2.0	6.3	2.5	13	7.3	68	82	2950 (2350)	Yes		
1LA8 355-6AB□□	2.2	6.5	2.8	13	13	71	86	2500 (2100)	Yes		
1LA8 357-6AB□□	2.2	6.5	2.8	13	16	71	86	2500 (2100)	Yes	Yes	Yes
1LA8 403-6AB□□	2.2	6.5	2.8	13	21	73	88	2200 (1900)/2100 <sup>2)</sup>			
1LA8 405-6AB□□	2.3	6.5	2.8	13	24	73	88	2200 (1900)/2100 <sup>2)</sup>	Yes		
1LA8 407-6AB□□	2.3	6.5	2.8	13	27	73	88	2200 (1900)/2100 <sup>2)</sup>	Yes		
1LA8 453-6AB□□	2.0	6.5	2.6	13	35	75	90	2100 (1700)/1800 <sup>2)</sup>	Yes	Yes	
1LA8 455-6AB□□	2.0	6.5	2.5	13	39	75	90	2100 (1700)/1800 <sup>2)</sup>	Yes	Yes	
1LA8 457-6AB□□	2.0	6.5	2.5	13	44	75	90	2100 (1700)/1800 <sup>2)</sup>	Yes	Yes	
<b>8-pole, 750 rpm at 50 Hz, 900 rpm at 60 Hz, temperature class 155 (F), used acc. to temperature class 130 (B), IP55 degree of protection</b>											
1LA8 315-8AB□□	2.1	6.0	2.3	13	6.0	65	79	2950 (2350)			
1LA8 317-8AB□□	2.1	6.0	2.3	13	7.3	65	79	2950 (2350)			
1LA8 355-8AB□□	2.1	6.1	2.4	13	13	67	82	2500 (2100)			
1LA8 357-8AB□□	2.1	6.1	2.4	13	16	67	82	2500 (2100)	Yes		
1LA8 403-8AB□□	2.0	6.5	2.6	13	21	69	84	2200 (1900)/2100 <sup>2)</sup>			
1LA8 405-8AB□□	2.1	6.5	2.6	13	24	69	84	2200 (1900)/2100 <sup>2)</sup>			
1LA8 407-8AB□□	2.1	6.5	2.6	13	27	69	84	2200 (1900)/2100 <sup>2)</sup>	Yes		
1LA8 453-8AB□□	2.0	6.6	2.4	13	35	71	86	2100 (1700)/1800 <sup>2)</sup>	Yes		
1LA8 455-8AB□□	2.0	6.6	2.4	13	39	71	86	2100 (1700)/1800 <sup>2)</sup>	Yes	Yes	
1LA8 457-8AB□□	2.0	6.6	2.4	13	44	71	86	2100 (1700)/1800 <sup>2)</sup>	Yes	Yes	

Values in brackets apply to the use of motors in hazardous areas.

<sup>1)</sup> Limit speeds for reinforced bearings (order code **K20**) for 6- and 8-pole motors on request.

<sup>2)</sup> For vertical type of construction IM V1.

# IEC Squirrel-Cage Motors

## Non-standard motors frame size 315 and above

Self-ventilated motors for converter-fed operation  
Cast-iron series 1LA8

### Selection and ordering data

Rated output at		Frame size	Operating values at rated output and sinusoidal supply							Order No.	Price	Weight of IM B3 type of construction approx.
50 Hz	60 Hz		Rated speed at 50 Hz	Rated torque at 50 Hz	Efficiency at 50 Hz 4/4-load	Efficiency at 50 Hz 3/4-load	Power factor at 50 Hz 4/4-load	Rated current at 50 Hz 400 V	Rated current at 50 Hz 690 V			
$P_{\text{rated}}$ kW	$P_{\text{rated}}$ kW	FS	$n_{\text{rated}}$ rpm	$T_{\text{rated}}$ Nm	$\eta_{\text{rated}}$ %	$\eta_{\text{rated}}$ %	$\cos\phi_{\text{rated}}$	$I_{\text{rated}}$ A	$I_{\text{rated}}$ A	For Order No. supplements for voltage and type of construction, see table below	$m$ kg	
<b>2-pole, 3000 rpm at 50 Hz, 3600 rpm at 60 Hz, temperature class 155 (F), used acc. to temperature class 155 (F), IP55 degree of protection, specially for operation on SINAMICS or SIMOVERT MASTERDRIVES with standard insulation for voltages ≤500 V</b>												
250	280	315	2979	801	96.2	96.2	0.90	415	240	1LA8 315-2PC□□	1300	
315	353	315	2979	1010	96.5	96.5	0.91	520	300	1LA8 317-2PC□□	1500	
355	398	355	2980	1140	96.5	96.5	0.90	590	340	1LA8 353-2PC□□	1900	
400	448	355	2980	1280	96.7	96.7	0.91	660	380	1LA8 355-2PC□□	2000	
500	560	355	2982	1600	97.1	97.1	0.91	820	475	1LA8 357-2PC□□	2200	
560	616	400	2985	1790	97.1	97.1	0.91	910	530	1LA8 403-2PC□□	2800	
630	693	400	2985	2020	97.1	97.1	0.91	1020	600	1LA8 405-2PC□□	3000	
710	781	400	2985	2270	97.3	97.3	0.91	–	670 <sup>1)</sup>	1LA8 407-2PC□□	3200	
800	–	450	2986	2560	97.2	97.2	0.91	–	760	1LA8 453-2PE□□	4000	
900	–	450	2986	2880	97.3	97.3	0.92	–	840	1LA8 455-2PE□□	4200	
1000	–	450	2986	3200	97.4	97.4	0.93	–	920	1LA8 457-2PE□□	4400	
<b>4-pole, 1500 rpm at 50 Hz, 1800 rpm at 60 Hz, temperature class 155 (F), used acc. to temperature class 155 (F), IP55 degree of protection, specially for operation on SINAMICS or SIMOVERT MASTERDRIVES with standard insulation for voltages ≤500 V</b>												
250	288	315	1488	1600	96.0	96.0	0.87	430	250 <sup>2)</sup>	1LA8 315-4PB□□	1300	
315	362	315	1488	2020	96.2	96.2	0.87	540	315 <sup>2)</sup>	1LA8 317-4PB□□	1500	
355	408	355	1488	2280	96.3	96.3	0.87	610	355 <sup>2)</sup>	1LA8 353-4PB□□	1900	
400	460	355	1488	2570	96.4	96.4	0.87	690	400 <sup>2)</sup>	1LA8 355-4PB□□	2000	
500	575	355	1488	3210	96.7	96.7	0.88	850	490 <sup>2)</sup>	1LA8 357-4PB□□	2200	
560	644	400	1492	3580	96.7	96.7	0.88	950	550	1LA8 403-4PB□□	2800	
630	725	400	1492	4030	96.9	96.9	0.88	1060	620	1LA8 405-4PB□□	3000	
710	817	400	1492	4540	97.0	97.0	0.89	–	690 <sup>1)</sup>	1LA8 407-4PB□□	3200	
800	920	450	1492	5120	97.0	97.0	0.88	–	780 <sup>1)</sup>	1LA8 453-4PC□□	4000	
900	1040	450	1492	5760	97.1	97.1	0.88	–	880	1LA8 455-4PC□□	4200	
1000	1150	450	1492	6400	97.1	97.1	0.89	–	970	1LA8 457-4PC□□	4400	

### Order No. supplements

Motor type	Penultimate position: Voltage code				Final position: Type of construction code			
	400 VΔ	400 VΔ/690 VY <sup>3)</sup>	500 VΔ	690 VΔ <sup>3)</sup>	Without flange IM B3	With flange IM V1 without protective cover <sup>4)</sup>	IM V1 with protective cover <sup>5)</sup>	IM B35
	4	8	5	7	0	8	4	6
1LA8 315-... □□ to 1LA8 405-... □□	○	□	○	–	□	✓ <sup>6)</sup>	✓ <sup>6)</sup>	✓
1LA8 407-... □□ to 1LA8 457-... □□	–	–	○	□	□	✓ <sup>6)</sup>	✓ <sup>6)</sup>	✓ <sup>7)</sup>

- Standard version
- Without additional charge
- ✓ With additional charge
- Not possible

Order other voltages with voltage code **9** in the penultimate position and the corresponding order code (see "Special versions" in the "Selection and ordering data" under "Voltages").

Voltages or frequencies that are not covered by the predefined options can be ordered with order code **L1Y**. In this case, the output, voltage and frequency must be specified.

<sup>1)</sup> Can also be supplied for 400 VΔ 50 Hz with voltage code **9** and order code **L1Y** (specify output, voltage and frequency).

<sup>2)</sup> **Standardline** for 1LA8 motors is a standardized range in specific versions which can be ordered with the order code **B20**. The delivery time is 4 weeks. Scope of the **Standardline**: 4-pole, types **1LA8 315**, **1LA8 317**, **1LA8 353**, **1LA8 355**, type of construction code **0** (IM B3), voltage code **4** (400 VΔ), **8** (400 VΔ/690 VY) or **5** (500 VΔ); can be ordered for converter-fed operation, but not in 690 V version. Possible order codes: **A23**, **A61**, **A72**, **G50**, **H70**, **H73**, **K09**, **K10**, **K45**, **K46**, **K57**, **K83**, **K84**, **K85**, **L00**, **L97**, **M58** (for frame size 315 only), **M88**, **Y53**.

<sup>3)</sup> Motors with standard insulation can only be operated with converter circuit ( $du/dt$  or sinusoidal filter).

<sup>4)</sup> For explosion-proof motors, the type of construction IM V1 without protective cover is not possible.

<sup>5)</sup> The "Second shaft extension" option, order code **K16** is not possible.

<sup>6)</sup> In 2-pole motors 60 Hz version, not possible for 1LA8 353 to 1LA8 457.

<sup>7)</sup> In 2-pole motors 60 Hz version, not possible for 1LA8 453 to 1LA8 457.



# IEC Squirrel-Cage Motors

## Non-standard motors frame size 315 and above

Self-ventilated motors for converter-fed operation  
Cast-iron series 1LA8

### Selection and ordering data (continued)

Order No.	At 50 Hz as multiple of rated torque	Torque class	Moment of inertia	Noise	Sound power level	Mech. limit speed <sup>1)</sup>		Parallel feeders required		
	$T_B/T_{rated}$	CL	J kgm <sup>2</sup>	Measuring surface sound pressure level at 50 Hz For rated output and sinusoidal supply, 50 Hz, tolerance +3 dB(A)	at 50 Hz	$n_{max}$ rpm	$f_{max}$ Hz	400 V	500 V	690 V
2-pole, 3000 rpm at 50 Hz, 3600 rpm at 60 Hz, temperature class 155 (F), used acc. to temperature class 155 (F), IP55 degree of protection, specially for operation on SINAMICS or SIMOVERT MASTERDRIVES with standard insulation for voltages ≤500 V										
1LA8 315-2PC□□	2.8	10	2.7	82 (75) <sup>2)</sup>	97 (90) <sup>2)</sup>	3600	60	Yes		
1LA8 317-2PC□□	2.8	10	3.3	82 (75) <sup>2)</sup>	97 (90) <sup>2)</sup>	3600	60	Yes		
1LA8 353-2PC□□	2.5	10	4.8	77 <sup>3)</sup>	92 <sup>3)</sup>	3600/3100 <sup>4)</sup>	60/52 <sup>4)</sup>	Yes	Yes	
1LA8 355-2PC□□	2.5	10	5.3	77 <sup>3)</sup>	92 <sup>3)</sup>	3600/3100 <sup>4)</sup>	60/52 <sup>4)</sup>	Yes	Yes	
1LA8 357-2PC□□	2.6	10	6.4	77 <sup>3)</sup>	92 <sup>3)</sup>	3600/3100 <sup>4)</sup>	60/52 <sup>4)</sup>	Yes		
1LA8 403-2PC□□	2.8	10	8.6	79 <sup>3)</sup>	94 <sup>3)</sup>	3600/3100 <sup>4)</sup>	60/52 <sup>4)</sup>	Yes		
1LA8 405-2PC□□	2.8	10	9.6	79 <sup>3)</sup>	94 <sup>3)</sup>	3600/3100 <sup>4)</sup>	60/52 <sup>4)</sup>	Yes	Yes	
1LA8 407-2PC□□	2.8	10	11	79 <sup>3)</sup>	94 <sup>3)</sup>	3600/3100 <sup>4)</sup>	60/52 <sup>4)</sup>	Yes		
1LA8 453-2PE□□	3.0	5	19	81 <sup>3)</sup>	96 <sup>3)</sup>	3000	50	Yes		
1LA8 455-2PE□□	2.8	5	21	81 <sup>3)</sup>	96 <sup>3)</sup>	3000	50	Yes	Yes	
1LA8 457-2PE□□	2.7	5	23	81 <sup>3)</sup>	96 <sup>3)</sup>	3000	50	Yes	Yes	
4-pole, 1500 rpm at 50 Hz, 1800 rpm at 60 Hz, temperature class 155 (F), used acc. to temperature class 155 (F), IP55 degree of protection, specially for operation on SINAMICS or SIMOVERT MASTERDRIVES with standard insulation for voltages ≤500 V										
1LA8 315-4PB□□	2.8	13	3.6	73	87	3000 (2650)	100 (88)	Yes		
1LA8 317-4PB□□	2.8	13	4.4	73	87	3000 (2650)	100 (88)	Yes		
1LA8 353-4PB□□	2.6	13	6.1	75	90	2500 (2350)	83 (78)	Yes	Yes	
1LA8 355-4PB□□	2.6	13	6.8	75	90	2500 (2350)	83 (78)	Yes	Yes	
1LA8 357-4PB□□	2.4	13	8.5	75	90	2500 (2350)	83 (78)	Yes		
1LA8 403-4PB□□	2.7	13	13	78	93	2200 (2100)/2100 <sup>4)</sup>	73 (70)/70 <sup>4)</sup>	Yes		
1LA8 405-4PB□□	2.7	13	14	78	93	2200 (2100)/2100 <sup>4)</sup>	73 (70)/70 <sup>4)</sup>	Yes	Yes	
1LA8 407-4PB□□	2.7	13	16	78	93	2200 (2100)/2100 <sup>4)</sup>	73 (70)/70 <sup>4)</sup>	Yes		
1LA8 453-4PC□□	2.6	10	23	81	96	2100 (1900)/1800 <sup>4)</sup>	70 (63)/60 <sup>4)</sup>	Yes		
1LA8 455-4PC□□	2.6	10	26	81	96	2100 (1900)/1800 <sup>4)</sup>	70 (63)/60 <sup>4)</sup>	Yes	Yes	
1LA8 457-4PC□□	2.6	10	28	81	96	2100 (1900)/1800 <sup>4)</sup>	70 (63)/60 <sup>4)</sup>	Yes	Yes	

Values in brackets apply to the use of motors in hazardous areas.

<sup>1)</sup> Limit speeds for reinforced bearings (order code **K20**) for 4-pole motors on request.

<sup>2)</sup> Low-noise version, 2-pole, in brackets. To reduce noise, 2-pole motors can be equipped with an axial fan that is only suitable for one direction of rotation. Clockwise rotation order code **K37**, counter-clockwise rotation **K38**.

<sup>3)</sup> In the standard version, the motors already have an axial fan for clockwise rotation. Order code **K37** is not necessary. For counter-clockwise rotation, order code **K38** is necessary.

<sup>4)</sup> For vertical type of construction IM V1.

# IEC Squirrel-Cage Motors

## Non-standard motors frame size 315 and above

Self-ventilated motors for converter-fed operation  
Cast-iron series 1LA8

### Selection and ordering data (continued)

Rated output at		Frame size	Operating values at rated output and sinusoidal supply							Order No.	Price	Weight of IM B3 type of construction approx.
50 Hz	60 Hz		Rated speed at 50 Hz	Rated torque at 50 Hz	Efficiency at 50 Hz 4/4-load	Efficiency at 50 Hz 3/4-load	Power factor at 50 Hz 4/4-load	Rated current at 50 Hz 400 V	Rated current at 50 Hz 690 V			
$P_{\text{rated}}$ kW	$P_{\text{rated}}$ kW	FS	$n_{\text{rated}}$ rpm	$T_{\text{rated}}$ Nm	$\eta_{\text{rated}}$ %	$\eta_{\text{rated}}$ %	$\cos\phi_{\text{rated}}$	$I_{\text{rated}}$ A	$I_{\text{rated}}$ A	For Order No. supplements for voltage and type of construction, see table below	$m$ kg	
<b>6-pole, 1000 rpm at 50 Hz, 1200 rpm at 60 Hz, temperature class 155 (F), used acc. to temperature class 155 (F), IP55 degree of protection, specially for operation on SINAMICS or SIMOVERT MASTERDRIVES with standard insulation for voltages ≤500 V</b>												
200	230	315	988	1930	95.7	95.8	0.86	345	200	<b>1LA8 315-6PBQQ</b>	1300	
250	288	315	988	2410	95.9	96.0	0.86	430	250	<b>1LA8 317-6PBQQ</b>	1500	
315	362	355	993	3040	96.2	96.2	0.86	540	315	<b>1LA8 355-6PBQQ</b>	2000	
400	460	355	993	3850	96.5	96.5	0.86	690	400	<b>1LA8 357-6PBQQ</b>	2200	
450	518	400	991	4330	96.5	96.5	0.86	780	455	<b>1LA8 403-6PBQQ</b>	2800	
500	575	400	991	4810	96.5	96.5	0.86	860	500	<b>1LA8 405-6PBQQ</b>	3000	
560	644	400	991	5390	96.7	96.7	0.86	960	560	<b>1LA8 407-6PBQQ</b>	3200	
630	725	450	993	6060	96.8	96.8	0.86	1100	630	<b>1LA8 453-6PBQQ</b>	4000	
710	817	450	993	6830	96.8	96.8	0.86	–	710 <sup>1)</sup>	<b>1LA8 455-6PBQQ</b>	4200	
800	920	450	993	7690	97.0	97.1	0.86	–	790 <sup>1)</sup>	<b>1LA8 457-6PBQQ</b>	4500	
<b>8-pole, 750 rpm at 50 Hz, 900 rpm at 60 Hz, temperature class 155 (F), used acc. to temperature class 155 (F), IP55 degree of protection, specially for operation on SINAMICS or SIMOVERT MASTERDRIVES with standard insulation for voltages ≤500 V</b>												
160	184	315	739	2070	94.9	94.9	0.82	295	172	<b>1LA8 315-8PBQQ</b>	1300	
200	230	315	739	2580	95.2	95.2	0.82	370	215	<b>1LA8 317-8PBQQ</b>	1500	
250	288	355	741	3220	95.7	95.7	0.82	460	265	<b>1LA8 355-8PBQQ</b>	2000	
315	362	355	741	4060	96.0	96.0	0.82	580	335	<b>1LA8 357-8PBQQ</b>	2200	
355	408	400	742	4570	96.1	96.1	0.82	650	375	<b>1LA8 403-8PBQQ</b>	2800	
400	460	400	742	5150	96.2	96.2	0.82	730	425	<b>1LA8 405-8PBQQ</b>	3000	
450	518	400	742	5790	96.3	96.3	0.82	820	475	<b>1LA8 407-8PBQQ</b>	3200	
500	575	450	744	6420	96.4	96.4	0.81	920	540	<b>1LA8 453-8PBQQ</b>	4000	
560	644	450	744	7190	96.5	96.5	0.81	1040	600	<b>1LA8 455-8PBQQ</b>	4200	
630	725	450	744	8090	96.6	96.6	0.81	1160	670	<b>1LA8 457-8PBQQ</b>	4500	

### Order No. supplements

Motor type	Penultimate position: Voltage code				Final position: Type of construction code			
	400 VΔ	400 VΔ/690 VY <sup>2)</sup>	500 VΔ	690 VΔ <sup>2)</sup>	Without flange IM B3	With flange IM V1 without protective cover <sup>3)</sup>	IM V1 with protective cover <sup>4)</sup>	IM B35
	4	8	5	7	0	8	4	6
<b>6-pole</b>								
<b>1LA8 315-... QQ</b> to <b>1LA8 453-... QQ</b>	○	□	○	–	□	✓	✓	✓
<b>1LA8 455-... QQ</b> to <b>1LA8 457-... QQ</b>	–	–	○	□	□	✓	✓	✓
<b>8-pole</b>								
<b>1LA8 315-... QQ</b> to <b>1LA8 457-... QQ</b>	○	□	○	– <sup>5)</sup>	□	✓	✓	✓

- Standard version
- Without additional charge
- ✓ With additional charge
- Not possible

Order other voltages with voltage code **9** in the penultimate position and the corresponding order code (see "Special versions" in the "Selection and ordering data" under "Voltages").

Voltages or frequencies that are not covered by the predefined options can be ordered with order code **L1Y**. In this case, the output, voltage and frequency must be specified.

<sup>1)</sup> Can also be supplied for 400 VΔ 50 Hz with voltage code **9** and order code **L1Y** (specify output, voltage and frequency).  
<sup>2)</sup> Motors with standard insulation can only be operated with converter circuit (du/dt or sinusoidal filter).

<sup>3)</sup> For explosion-proof motors, the type of construction IM V1 without protective cover is not possible.  
<sup>4)</sup> The "Second shaft extension" option, order code **K16** is not possible.  
<sup>5)</sup> As special version with voltage code **9** and order code **L1Y** (specify output, voltage and frequency).

# IEC Squirrel-Cage Motors

## Non-standard motors frame size 315 and above

Self-ventilated motors for converter-fed operation  
Cast-iron series 1LA8

### Selection and ordering data (continued)

Order No.	At 50 Hz as multiple of rated torque	Torque class	Moment of inertia	Noise		Mech. limit speed <sup>1)</sup>		Parallel feeders required		
				Measuring surface sound pressure level at 50 Hz For rated output and sinusoidal supply, 50 Hz, tolerance +3 dB(A)	Sound power level at 50 Hz	$n_{max}$ rpm	$f_{max}$ Hz	400 V	500 V	690 V
	$T_B/T_{rated}$	CL	J kgm <sup>2</sup>	$L_{pFA}$ dB(A)	$L_{WA}$ dB(A)					
<b>6-pole, 1000 rpm at 50 Hz, 1200 rpm at 60 Hz, temperature class 155 (F), used acc. to temperature class 155 (F), IP55 degree of protection, specially for operation on SINAMICS or SIMOVERT MASTERDRIVES with standard insulation for voltages ≤500 V</b>										
<b>1LA8 315-6PB□□</b>	2.5	13	6.0	68	82	2950 (2350)	147 (117)			
<b>1LA8 317-6PB□□</b>	2.5	13	7.3	68	82	2950 (2350)	147 (117)	Yes		
<b>1LA8 355-6PB□□</b>	2.8	13	13	71	86	2500 (2100)	125 (105)	Yes		
<b>1LA8 357-6PB□□</b>	2.8	13	16	71	86	2500 (2100)	125 (105)	Yes	Yes	
<b>1LA8 403-6PB□□</b>	2.8	13	21	73	88	2200 (1900)/2100 <sup>2)</sup>	110 (95)/105 <sup>2)</sup>			
<b>1LA8 405-6PB□□</b>	2.8	13	24	73	88	2200 (1900)/2100 <sup>2)</sup>	110 (95)/105 <sup>2)</sup>	Yes		
<b>1LA8 407-6PB□□</b>	2.8	13	27	73	88	2200 (1900)/2100 <sup>2)</sup>	110 (95)/105 <sup>2)</sup>	Yes		
<b>1LA8 453-6PB□□</b>	2.6	13	35	75	90	2100 (1700)/1800 <sup>2)</sup>	105 (85)/90 <sup>2)</sup>	Yes	Yes	
<b>1LA8 455-6PB□□</b>	2.5	13	39	75	90	2100 (1700)/1800 <sup>2)</sup>	105 (85)/90 <sup>2)</sup>		Yes	
<b>1LA8 457-6PB□□</b>	2.5	13	44	75	90	2100 (1700)/1800 <sup>2)</sup>	105 (85)/90 <sup>2)</sup>		Yes	
<b>8-pole, 750 rpm at 50 Hz, 900 rpm at 60 Hz, temperature class 155 (F), used acc. to temperature class 155 (F), IP55 degree of protection, specially for operation on SINAMICS or SIMOVERT MASTERDRIVES with standard insulation for voltages ≤500 V</b>										
<b>1LA8 315-8PB□□</b>	2.3	13	6.0	65	79	2950 (2350)	196 (156)			
<b>1LA8 317-8PB□□</b>	2.3	13	7.3	65	79	2950 (2350)	196 (156)			
<b>1LA8 355-8PB□□</b>	2.4	13	13	67	82	2500 (2100)	166 (140)			
<b>1LA8 357-8PB□□</b>	2.4	13	16	67	82	2500 (2100)	166 (140)	Yes		
<b>1LA8 403-8PB□□</b>	2.6	13	21	69	84	2200 (1900)/2100 <sup>2)</sup>	146 (126)/140 <sup>2)</sup>			
<b>1LA8 405-8PB□□</b>	2.6	13	24	69	84	2200 (1900)/2100 <sup>2)</sup>	146 (126)/140 <sup>2)</sup>			
<b>1LA8 407-8PB□□</b>	2.6	13	27	69	84	2200 (1900)/2100 <sup>2)</sup>	146 (126)/140 <sup>2)</sup>	Yes		
<b>1LA8 453-8PB□□</b>	2.4	13	35	71	86	2100 (1700)/1800 <sup>2)</sup>	140 (113)/120 <sup>2)</sup>	Yes	Yes	
<b>1LA8 455-8PB□□</b>	2.4	13	39	71	86	2100 (1700)/1800 <sup>2)</sup>	140 (113)/120 <sup>2)</sup>	Yes	Yes	
<b>1LA8 457-8PB□□</b>	2.4	13	44	71	86	2100 (1700)/1800 <sup>2)</sup>	140 (113)/120 <sup>2)</sup>	Yes	Yes	

Values in brackets apply to the use of motors in hazardous areas.

<sup>1)</sup> Limit speeds for reinforced bearings (order code **K20**) for 6- and 8-pole motors on request.

<sup>2)</sup> For vertical type of construction IM V1.

# IEC Squirrel-Cage Motors

## Non-standard motors frame size 315 and above

Self-ventilated motors for converter-fed operation  
Cast-iron series 1LA8

### Selection and ordering data (continued)

Rated output at		Frame size	Operating values at rated output and sinusoidal supply						Order No.	Price	Weight of IM B3 type of construction approx.
50 Hz	60 Hz		Rated speed at 50 Hz	Rated torque at 50 Hz	Efficiency at 50 Hz 4/4-load	Efficiency at 50 Hz 3/4-load	Power factor at 50 Hz 4/4-load	Rated current at 50 Hz 690 V			
$P_{\text{rated}}$ kW	$P_{\text{rated}}$ kW	FS	$n_{\text{rated}}$ rpm	$T_{\text{rated}}$ Nm	$\eta_{\text{rated}}$ %	$\eta_{\text{rated}}$ %	$\cos\phi_{\text{rated}}$	$I_{\text{rated}}$ A		$m$ kg	
<b>2-pole, 3000 rpm at 50 Hz, 3600 rpm at 60 Hz, temperature class 155 (F), used acc. to temperature class 155 (F), IP55 degree of protection, specially for operation on SINAMICS or SIMOVERT MASTERDRIVES with special insulation for voltages &gt;500 to 690 V</b>											
240	270	315	2978	770	96.0	96.0	0.90	230	<b>1LA8 315-2PM8□</b>	1300	
300	335	315	2978	962	96.4	96.4	0.91	285	<b>1LA8 317-2PM8□</b>	1500	
345	385	355	2981	1105	96.4	96.4	0.90	335	<b>1LA8 353-2PM8□</b>	1900	
390	435	355	2981	1249	96.6	96.6	0.91	370	<b>1LA8 355-2PM8□</b>	2000	
485	545	355	2982	1553	97.0	97.0	0.91	460	<b>1LA8 357-2PM8□</b>	2200	
545	600	400	2986	1743	97.1	97.1	0.91	520	<b>1LA8 403-2PM7□</b>	2800	
610	670	400	2986	1951	97.1	97.1	0.91	580	<b>1LA8 405-2PM7□</b>	3000	
680	750	400	2986	2175	97.2	97.2	0.92	640	<b>1LA8 407-2PM7□</b>	3200	
775	-	450	2987	2478	97.2	97.2	0.92	730	<b>1LA8 453-2PM7□</b>	4000	
875	-	450	2987	2798	97.3	97.3	0.92	820	<b>1LA8 455-2PM7□</b>	4200	
970	-	450	2987	3101	97.4	97.4	0.93	900	<b>1LA8 457-2PM7□</b>	4400	
<b>4-pole, 1500 rpm at 50 Hz, 1800 rpm at 60 Hz, temperature class 155 (F), used acc. to temperature class 155 (F), IP55 degree of protection, specially for operation on SINAMICS or SIMOVERT MASTERDRIVES with special insulation for voltages &gt;500 to 690 V</b>											
235	270	315	1485	1511	95.8	95.8	0.87	235	<b>1LA8 315-4PM8□</b>	1300	
290	335	315	1485	1865	95.9	95.9	0.87	285	<b>1LA8 317-4PM8□</b>	1500	
340	390	355	1488	2182	96.0	96.0	0.87	340	<b>1LA8 353-4PM8□</b>	1900	
385	445	355	1488	2471	96.2	96.2	0.87	385	<b>1LA8 355-4PM8□</b>	2000	
480	550	355	1488	3081	96.4	96.4	0.87	480	<b>1LA8 357-4PM8□</b>	2200	
545	625	400	1491	3491	96.5	96.5	0.88	540	<b>1LA8 403-4PM8□</b>	2800	
615	710	400	1491	3939	96.7	96.7	0.88	600	<b>1LA8 405-4PM8□</b>	3000	
690	795	400	1491	4420	96.9	96.9	0.89	670	<b>1LA8 407-4PM7□</b>	3200	
785	905	450	1492	5025	96.8	96.8	0.88	770	<b>1LA8 453-4PM7□</b>	4000	
880	1010	450	1492	5633	97.0	97.0	0.87	870	<b>1LA8 455-4PM7□</b>	4200	
980	1125	450	1492	6273	97.1	97.1	0.89	950	<b>1LA8 457-4PM7□</b>	4400	

### Order No. supplements

Motor type	Final position: Type of construction code			
	Without flange IM B3	With flange IM V1 without protective cover	IM V1 with protective cover	IM B35
<b>1LA8 315-...□□</b> to <b>1LA8 457-...□□</b>	<b>0</b>	<b>8</b>	<b>4</b>	<b>6</b>
	□	✓	✓	✓

- Standard version
- ✓ With additional charge

The voltage code is already in the Order No. as the penultimate position.

Assignment:

**7** = 690 VΔ

**8** = 400 VΔ/690 VY

Order other voltages with voltage code **9** in the penultimate position and the corresponding order code (see "Special versions" in the "Selection and ordering data" under "Voltages").

Voltages or frequencies that are not covered by the predefined options can be ordered with order code **L1Y**. In this case, the output, voltage and frequency must be specified.

# IEC Squirrel-Cage Motors

## Non-standard motors frame size 315 and above

Self-ventilated motors for converter-fed operation  
Cast-iron series 1LA8

### Selection and ordering data (continued)

Order No.	Breakdown torque at 50 Hz as multiple of rated torque	Torque class	Moment of inertia	Noise		Mech. limit speed <sup>1)</sup>		Parallel feeders required		
				Measuring surface sound pressure level at 50 Hz For rated output and sinusoidal supply, 50 Hz, tolerance +3 dB(A)	Sound power level at 50 Hz	$n_{max}$ rpm	$f_{max}$ Hz	400 V	500 V	690 V
	$T_B/T_{rated}$	CL	J kgm <sup>2</sup>	$L_{pFA}$ dB(A)	$L_{WA}$ dB(A)					
<b>2-pole, 3000 rpm at 50 Hz, 3600 rpm at 60 Hz, temperature class 155 (F), used acc. to temperature class 155 (F), IP55 degree of protection, specially for operation on SINAMICS or SIMOVERT MASTERDRIVES with special insulation for voltages &gt;500 to 690 V</b>										
1LA8 315-2PM8□	3.0	10	2.7	82 (75) <sup>2)</sup>	97 (90) <sup>2)</sup>	3600	60		Yes	
1LA8 317-2PM8□	3.0	10	3.3	82 (75) <sup>2)</sup>	97 (90) <sup>2)</sup>	3600	60		Yes	
1LA8 353-2PM8□	2.6	10	4.8	77 <sup>3)</sup>	92 <sup>3)</sup>	3600/3100 <sup>4)</sup>	60/52 <sup>4)</sup>		Yes	Yes
1LA8 355-2PM8□	2.6	10	5.3	77 <sup>3)</sup>	92 <sup>3)</sup>	3600/3100 <sup>4)</sup>	60/52 <sup>4)</sup>		Yes	Yes
1LA8 357-2PM8□	2.6	10	6.4	77 <sup>3)</sup>	92 <sup>3)</sup>	3600/3100 <sup>4)</sup>	60/52 <sup>4)</sup>		Yes	
1LA8 403-2PM7□	3.0	10	8.6	79 <sup>3)</sup>	94 <sup>3)</sup>	3600/3100 <sup>4)</sup>	60/52 <sup>4)</sup>		Yes	
1LA8 405-2PM7□	3.1	10	9.6	79 <sup>3)</sup>	94 <sup>3)</sup>	3600/3100 <sup>4)</sup>	60/52 <sup>4)</sup>		Yes	Yes
1LA8 407-2PM7□	3.0	10	11	79 <sup>3)</sup>	94 <sup>3)</sup>	3600/3100 <sup>4)</sup>	60/52 <sup>4)</sup>		Yes	
1LA8 453-2PM7□	2.8	5	19	81 <sup>3)</sup>	96 <sup>3)</sup>	3000	50		Yes	
1LA8 455-2PM7□	2.8	5	21	81 <sup>3)</sup>	96 <sup>3)</sup>	3000	50		Yes	Yes
1LA8 457-2PM7□	2.8	5	23	81 <sup>3)</sup>	96 <sup>3)</sup>	3000	50		Yes	Yes
<b>4-pole, 1500 rpm at 50 Hz, 1800 rpm at 60 Hz, temperature class 155 (F), used acc. to temperature class 155 (F), IP55 degree of protection, specially for operation on SINAMICS or SIMOVERT MASTERDRIVES with special insulation for voltages &gt;500 to 690 V</b>										
1LA8 315-4PM8□	2.8	13	3.6	73	87	3000 (2650)	100 (88)		Yes	
1LA8 317-4PM8□	2.8	13	4.4	73	87	3000 (2650)	100 (88)		Yes	
1LA8 353-4PM8□	2.6	13	6.1	75	90	2500 (2350)	83 (78)		Yes	Yes
1LA8 355-4PM8□	2.6	13	6.8	75	90	2500 (2350)	83 (78)		Yes	Yes
1LA8 357-4PM8□	2.5	13	8.5	75	90	2500 (2350)	83 (78)		Yes	
1LA8 403-4PM8□	2.6	13	13	78	93	2200 (2100)/2100 <sup>4)</sup>	73 (70)/70 <sup>4)</sup>		Yes	
1LA8 405-4PM8□	2.7	13	14	78	93	2200 (2100)/2100 <sup>4)</sup>	73 (70)/70 <sup>4)</sup>		Yes	Yes
1LA8 407-4PM7□	2.6	13	16	78	93	2200 (2100)/2100 <sup>4)</sup>	73 (70)/70 <sup>4)</sup>		Yes	
1LA8 453-4PM7□	2.5	10	23	81	96	2100 (1900)/1800 <sup>4)</sup>	70 (63)/60 <sup>4)</sup>		Yes	
1LA8 455-4PM7□	2.6	10	26	81	96	2100 (1900)/1800 <sup>4)</sup>	70 (63)/60 <sup>4)</sup>		Yes	Yes
1LA8 457-4PM7□	2.6	10	28	81	96	2100 (1900)/1800 <sup>4)</sup>	70 (63)/60 <sup>4)</sup>		Yes	Yes

Values in brackets apply to the use of motors in hazardous areas.

<sup>1)</sup> Limit speeds for reinforced bearings (order code **K20**) for 4-pole motors on request.

<sup>2)</sup> Low-noise version, 2-pole, in brackets. To reduce noise, 2-pole motors can be equipped with an axial fan that is only suitable for one direction of rotation. Clockwise rotation order code **K37**, counter-clockwise rotation **K38**.

<sup>3)</sup> In the standard version, the motors already have an axial fan for clockwise rotation. Order code **K37** is not necessary. For counter-clockwise rotation, order code **K38** is necessary.

<sup>4)</sup> For vertical type of construction IM V1.

# IEC Squirrel-Cage Motors

## Non-standard motors frame size 315 and above

Self-ventilated motors for converter-fed operation  
Cast-iron series 1LA8

### Selection and ordering data (continued)

Rated output at		Frame size	Operating values at rated output and sinusoidal supply						Order No.	Price	Weight of IM B3 type of construction approx.
50 Hz	60 Hz		Rated speed at 50 Hz	Rated torque at 50 Hz	Efficiency at 50 Hz 4/4-load	Efficiency at 50 Hz 3/4-load	Power factor at 50 Hz 4/4-load	Rated current at 50 Hz 690 V			
$P_{\text{rated}}$ kW	$P_{\text{rated}}$ kW	FS	$n_{\text{rated}}$ rpm	$T_{\text{rated}}$ Nm	$\eta_{\text{rated}}$ %	$\eta_{\text{rated}}$ %	$\cos\phi_{\text{rated}}$	$I_{\text{rated}}$ A		$m$ kg	
<b>6-pole, 1000 rpm at 50 Hz, 1200 rpm at 60 Hz, temperature class 155 (F), used acc. to temperature class 155 (F), IP55 degree of protection, specially for operation on SINAMICS or SIMOVERT MASTERDRIVES with special insulation for voltages &gt;500 to 690 V</b>											
190	220	315	990	1833	95.5	95.6	0.85	196	<b>1LA8 315-6PM8Q</b>	1300	
235	270	315	990	2267	95.7	95.8	0.86	240	<b>1LA8 317-6PM8Q</b>	1500	
300	345	355	992	2888	96.2	96.2	0.86	305	<b>1LA8 355-6PM8Q</b>	2000	
380	435	355	992	3658	96.4	96.4	0.86	385	<b>1LA8 357-6PM8Q</b>	2200	
435	500	400	993	4184	96.4	96.4	0.85	445	<b>1LA8 403-6PM8Q</b>	2800	
485	560	400	993	4664	96.5	96.5	0.86	490	<b>1LA8 405-6PM8Q</b>	3000	
545	625	400	993	5241	96.6	96.6	0.86	550	<b>1LA8 407-6PM8Q</b>	3200	
615	705	450	993	5915	96.8	96.8	0.84	630	<b>1LA8 453-6PM8Q</b>	4000	
690	795	450	993	6636	96.8	96.8	0.85	700	<b>1LA8 455-6PM7Q</b>	4200	
780	895	450	993	7502	96.9	97.0	0.85	790	<b>1LA8 457-6PM7Q</b>	4500	
<b>8-pole, 750 rpm at 50 Hz, 900 rpm at 60 Hz, temperature class 155 (F), used acc. to temperature class 155 (F), IP55 degree of protection, specially for operation on SINAMICS or SIMOVERT MASTERDRIVES with special insulation for voltages &gt;500 to 690 V</b>											
145	165	315	740	1871	94.6	94.6	0.79	162	<b>1LA8 315-8PM8Q</b>	1300	
180	205	315	740	2323	94.9	94.9	0.80	198	<b>1LA8 317-8PM8Q</b>	1500	
230	265	355	743	2956	95.5	95.5	0.80	250	<b>1LA8 355-8PM8Q</b>	2000	
290	335	355	743	3727	95.7	95.7	0.81	315	<b>1LA8 357-8PM8Q</b>	2200	
335	385	400	743	4306	96.0	96.0	0.80	365	<b>1LA8 403-8PM8Q</b>	2800	
375	430	400	743	4820	96.1	96.1	0.80	410	<b>1LA8 405-8PM8Q</b>	3000	
425	490	400	743	5463	96.2	96.2	0.79	470	<b>1LA8 407-8PM8Q</b>	3200	
485	560	450	745	6217	96.5	96.5	0.78	540	<b>1LA8 453-8PM8Q</b>	4000	
545	625	450	745	6986	96.6	96.6	0.78	610	<b>1LA8 455-8PM8Q</b>	4200	
600	690	450	745	7691	96.7	96.7	0.79	660	<b>1LA8 457-8PM8Q</b>	4500	

### Order No. supplements

Motor type	Final position: Type of construction code			
	Without flange		With flange	
	IM B3	IM V1 without protective cover	IM V1 with protective cover	IM B35
<b>1LA8 315-... □□</b> to <b>1LA8 457-... □□</b>	<b>0</b> □	<b>8</b> ✓	<b>4</b> ✓	<b>6</b> ✓

- Standard version
- ✓ With additional charge

The voltage code is already in the Order No. as the penultimate position.

Assignment:

**7** = 690 VΔ

**8** = 400 VΔ/690 VY

Order other voltages with voltage code **9** in the penultimate position and the corresponding order code (see "Special versions" in the "Selection and ordering data" under "Voltages").

Voltages or frequencies that are not covered by the predefined options can be ordered with order code **L1Y**. In this case, the output, voltage and frequency must be specified.

# IEC Squirrel-Cage Motors

## Non-standard motors frame size 315 and above

Self-ventilated motors for converter-fed operation  
Cast-iron series 1LA8

### Selection and ordering data (continued)

Order No.	Breakdown torque at 50 Hz as multiple of rated torque $T_B/T_{rated}$	Torque class CL	Moment of inertia J kgm <sup>2</sup>	Noise		Mech. limit speed <sup>1)</sup>		Parallel feeders required		
				Measuring surface sound pressure level at 50 Hz For rated output and sinusoidal supply, 50 Hz, tolerance +3 dB(A) $L_{pFA}$ dB(A)	Sound power level at 50 Hz $L_{WA}$ dB(A)	$n_{max}$ rpm	$f_{max}$ Hz	400 V	500 V	690 V
<b>6-pole, 1000 rpm at 50 Hz, 1200 rpm at 60 Hz, temperature class 155 (F), used acc. to temperature class 155 (F), IP55 degree of protection, specially for operation on SINAMICS or SIMOVERT MASTERDRIVES with special insulation for voltages &gt;500 to 690 V</b>										
<b>1LA8 315-6PM8□</b>	2.7	13	6.0	68	82	2950 (2350)	147 (117)			
<b>1LA8 317-6PM8□</b>	2.7	13	7.3	68	82	2950 (2350)	147 (117)	Yes		
<b>1LA8 355-6PM8□</b>	2.8	13	13	71	86	2500 (2100)	125 (105)	Yes		
<b>1LA8 357-6PM8□</b>	2.9	13	16	71	86	2500 (2100)	125 (105)	Yes	Yes	
<b>1LA8 403-6PM8□</b>	2.8	13	21	73	88	2200 (1900)/2100 <sup>2)</sup>	110 (95)/105 <sup>2)</sup>			
<b>1LA8 405-6PM8□</b>	2.8	13	24	73	88	2200 (1900)/2100 <sup>2)</sup>	110 (95)/105 <sup>2)</sup>	Yes		
<b>1LA8 407-6PM8□</b>	2.7	13	27	73	88	2200 (1900)/2100 <sup>2)</sup>	110 (95)/105 <sup>2)</sup>	Yes		
<b>1LA8 453-6PM8□</b>	2.7	13	35	75	90	2100 (1700)/1800 <sup>2)</sup>	105 (85)/90 <sup>2)</sup>	Yes	Yes	
<b>1LA8 455-6PM7□</b>	2.5	13	39	75	90	2100 (1700)/1800 <sup>2)</sup>	105 (85)/90 <sup>2)</sup>		Yes	
<b>1LA8 457-6PM7□</b>	2.6	13	44	75	90	2100 (1700)/1800 <sup>2)</sup>	105 (85)/90 <sup>2)</sup>		Yes	
<b>8-pole, 750 rpm at 50 Hz, 900 rpm at 60 Hz, temperature class 155 (F), used acc. to temperature class 155 (F), IP55 degree of protection, specially for operation on SINAMICS or SIMOVERT MASTERDRIVES with special insulation for voltages &gt;500 to 690 V</b>										
<b>1LA8 315-8PM8□</b>	2.5	13	6.0	65	79	2950 (2350)	196 (156)			
<b>1LA8 317-8PM8□</b>	2.5	13	7.3	65	79	2950 (2350)	196 (156)			
<b>1LA8 355-8PM8□</b>	2.4	13	13	67	82	2500 (2100)	166 (140)			
<b>1LA8 357-8PM8□</b>	2.4	13	16	67	82	2500 (2100)	166 (140)	Yes		
<b>1LA8 403-8PM8□</b>	2.6	13	21	69	84	2200 (1900)/2100 <sup>2)</sup>	146 (126)/140 <sup>2)</sup>			
<b>1LA8 405-8PM8□</b>	2.7	13	24	69	84	2200 (1900)/2100 <sup>2)</sup>	146 (126)/140 <sup>2)</sup>			
<b>1LA8 407-8PM8□</b>	2.7	13	27	69	84	2200 (1900)/2100 <sup>2)</sup>	146 (126)/140 <sup>2)</sup>	Yes		
<b>1LA8 453-8PM8□</b>	2.5	13	35	71	86	2100 (1700)/1800 <sup>2)</sup>	140 (113)/120 <sup>2)</sup>	Yes	Yes	
<b>1LA8 455-8PM8□</b>	2.5	13	39	71	86	2100 (1700)/1800 <sup>2)</sup>	140 (113)/120 <sup>2)</sup>	Yes	Yes	
<b>1LA8 457-8PM8□</b>	2.5	13	44	71	86	2100 (1700)/1800 <sup>2)</sup>	140 (113)/120 <sup>2)</sup>	Yes	Yes	

Values in brackets apply to the use of motors in hazardous areas.

<sup>1)</sup> Limit speeds for reinforced bearings (order code **K20**) for 6- and 8-pole motors on request.

<sup>2)</sup> For vertical type of construction IM V1.

# IEC Squirrel-Cage Motors

## Non-standard motors frame size 315 and above

Forced-air cooled motors with separately driven fan for converter-fed operation – Cast-iron series 1PQ8

### Selection and ordering data

Rated output at		Frame size	Operating values at rated output and sinusoidal supply							Order No.	Price	Weight of IM B3 type of construction approx.
50 Hz	60 Hz		Rated speed at 50 Hz	Rated torque at 50 Hz	Efficiency at 50 Hz 4/4-load	Efficiency at 50 Hz 3/4-load	Power factor at 50 Hz 4/4-load	Rated current at 50 Hz 400 V	Rated current at 50 Hz 690 V			
$P_{\text{rated}}$ kW	$P_{\text{rated}}$ kW	FS	$n_{\text{rated}}$ rpm	$T_{\text{rated}}$ Nm	$\eta_{\text{rated}}$ %	$\eta_{\text{rated}}$ %	$\cos \varphi_{\text{rated}}$	$I_{\text{rated}}$ A	$I_{\text{rated}}$ A	For Order No. supplements for voltage and type of construction, see table below	$m$ kg	
<b>2-pole, 3000 rpm at 50 Hz, 3600 rpm at 60 Hz, temperature class 155 (F), used acc. to temperature class 155 (F), IP55 degree of protection, specially for operation on SINAMICS or SIMOVERT MASTERDRIVES with standard insulation for voltages ≤500 V</b>												
250	280	315	2979	801	96.2	96.2	0.90	415	240	1PQ8 315-2PC□□	1400	
315	353	315	2979	1010	96.5	96.5	0.91	520	300	1PQ8 317-2PC□□	1600	
355	398	355	2980	1140	96.5	96.5	0.90	590	340	1PQ8 353-2PC□□	2000	
400	448	355	2980	1280	96.7	96.7	0.91	660	380	1PQ8 355-2PC□□	2100	
500	560	355	2982	1600	97.1	97.1	0.91	820	475	1PQ8 357-2PC□□	2300	
560	616	400	2985	1790	97.1	97.1	0.91	910	530	1PQ8 403-2PC□□	2900	
630	693	400	2985	2020	97.1	97.1	0.91	1020	600	1PQ8 405-2PC□□	3100	
710	781	400	2985	2270	97.3	97.3	0.91	–	670 <sup>1)</sup>	1PQ8 407-2PC□□	3300	
800	–	450	2986	2560	97.2	97.2	0.91	–	760	1PQ8 453-2PE□□	4100	
900	–	450	2986	2880	97.3	97.3	0.92	–	840	1PQ8 455-2PE□□	4300	
1000	–	450	2986	3200	97.4	97.4	0.93	–	920	1PQ8 457-2PE□□	4500	
<b>4-pole, 1500 rpm at 50 Hz, 1800 rpm at 60 Hz, temperature class 155 (F), used acc. to temperature class 155 (F), IP55 degree of protection, specially for operation on SINAMICS or SIMOVERT MASTERDRIVES with standard insulation for voltages ≤500 V</b>												
250	288	315	1488	1600	96.0	96.0	0.87	430	250	1PQ8 315-4PB□□	1400	
315	362	315	1488	2020	96.2	96.2	0.87	540	315	1PQ8 317-4PB□□	1600	
355	408	355	1488	2280	96.3	96.3	0.87	610	355	1PQ8 353-4PB□□	2000	
400	460	355	1488	2570	96.4	96.4	0.87	690	400	1PQ8 355-4PB□□	2100	
500	575	355	1488	3210	96.7	96.7	0.88	850	490	1PQ8 357-4PB□□	2300	
560	644	400	1492	3580	96.7	96.7	0.88	950	550	1PQ8 403-4PB□□	2900	
630	725	400	1492	4030	96.9	96.9	0.88	1060	620	1PQ8 405-4PB□□	3100	
710	817	400	1492	4540	97.0	97.0	0.89	–	690 <sup>1)</sup>	1PQ8 407-4PB□□	3300	
800	920	450	1492	5120	97.0	97.0	0.88	–	780 <sup>1)</sup>	1PQ8 453-4PC□□	4100	
900	1040	450	1492	5760	97.1	97.1	0.88	–	880	1PQ8 455-4PC□□	4300	
1000	1150	450	1492	6400	97.1	97.1	0.89	–	970	1PQ8 457-4PC□□	4500	

### Order No. supplements

Motor type	Penultimate position: Voltage code				Final position: Type of construction code			
	400 VΔ	400 VΔ/690 VY <sup>2)</sup>	500 VΔ	690 VΔ <sup>2)</sup>	Without flange IM B3	With flange IM V1 without protective cover <sup>3)</sup>	IM V1 with protective cover <sup>4)</sup>	IM B35
	4	8	5	7	0	8	4	6
1PQ8 315-...□□ to 1PQ8 405-...□□	○	□	○	–	□	✓	✓	✓
1PQ8 407-...□□ to 1PQ8 457-...□□	–	–	○	□	□	✓	✓	✓

- Standard version
- Without additional charge
- ✓ With additional charge
- Not possible

Order other voltages with voltage code **9** in the penultimate position and the corresponding order code (see "Special versions" in the "Selection and ordering data" under "Voltages").

Voltages or frequencies that are not covered by the predefined options can be ordered with order code **L1Y**. In this case, the output, voltage and frequency must be specified.

<sup>1)</sup> Can also be supplied for 400 VΔ 50 Hz with voltage code "9" and order code **L1Y** (specify output, voltage and frequency).  
<sup>2)</sup> Motors with standard insulation can only be operated with converter circuit (du/dt or sinusoidal filter).

<sup>3)</sup> For explosion-proof motors, the type of construction IM V1 without protective cover is not possible.  
<sup>4)</sup> The "Second shaft extension" option, order code **K16** is not possible.



# IEC Squirrel-Cage Motors

## Non-standard motors frame size 315 and above

Forced-air cooled motors with separately driven fan  
for converter-fed operation – Cast-iron series 1PQ8

### Selection and ordering data (continued)

Order No.	Breakdown torque at 50 Hz as multiple of rated torque	Torque class	Moment of inertia	Technical data of the separately driven fan				Measuring surface sound pressure level at 50 Hz	Sound power level at 50 Hz	Mech. limit speed <sup>1)</sup>	Parallel feeders required				
				Power consumption with	Rated current at	50 Hz	60 Hz				400 V	460 V	50 Hz	60 Hz	For rated output, 50 Hz, tolerance +3 dB(A)
	$T_B/T_{rated}$	CL	$J$ kgm <sup>2</sup>	$P$ kW	$P$ kW	$I$ A	$I$ A	$L_{pA}$ dB(A)	$L_{WA}$ dB(A)	$n_{max.}$ rpm	$f_{max.}$ Hz				
<b>2-pole, 3000 rpm at 50 Hz, 3600 rpm at 60 Hz, temperature class 155 (F), used acc. to temperature class 155 (F), IP55 degree of protection, specially for operation on SINAMICS or SIMOVERT MASTERDRIVES with standard insulation for voltages ≤500 V</b>															
1PQ8 315-2PC□□	2.8	10	2.7	0.75	1.23	3.4	3.3	79	94	3600	60		Yes		
1PQ8 317-2PC□□	2.8	10	3.3	0.75	1.23	3.4	3.3	79	94	3600	60		Yes		
1PQ8 353-2PC□□	2.5	10	4.8	1.3	2.2	6.4	6.2	81	96	3600/3100 <sup>2)</sup>	60/52 <sup>2)</sup>	Yes	Yes		
1PQ8 355-2PC□□	2.5	10	5.3	1.3	2.2	6.4	6.2	81	96	3600/3100 <sup>2)</sup>	60/52 <sup>2)</sup>	Yes	Yes		
1PQ8 357-2PC□□	2.6	10	6.4	1.3	2.2	6.4	6.2	81	96	3600/3100 <sup>2)</sup>	60/52 <sup>2)</sup>	Yes			
1PQ8 403-2PC□□	2.8	10	8.6	1.6	2.8	6.4	6.2	83	98	3600/3100 <sup>2)</sup>	60/52 <sup>2)</sup>	Yes			
1PQ8 405-2PC□□	2.8	10	9.6	1.6	2.8	6.4	6.2	83	98	3600/3100 <sup>2)</sup>	60/52 <sup>2)</sup>	Yes	Yes		
1PQ8 407-2PC□□	2.8	10	11	1.6	2.8	6.4	6.2	83	98	3600/3100 <sup>2)</sup>	60/52 <sup>2)</sup>		Yes		
1PQ8 453-2PE□□	3.0	5	19	3.0	4.2	8.2	7.7	86	101	3000	50		Yes		
1PQ8 455-2PE□□	2.8	5	21	3.0	4.2	8.2	7.7	86	101	3000	50		Yes Yes		
1PQ8 457-2PE□□	2.7	5	23	3.0	4.2	8.2	7.7	86	101	3000	50		Yes Yes		
<b>4-pole, 1500 rpm at 50 Hz, 1800 rpm at 60 Hz, temperature class 155 (F), used acc. to temperature class 155 (F), IP55 degree of protection, specially for operation on SINAMICS or SIMOVERT MASTERDRIVES with standard insulation for voltages ≤500 V</b>															
1PQ8 315-4PB□□	2.8	13	3.6	0.75	1.23	3.4	3.3	79	93	3000 (2650)	100 (88)		Yes		
1PQ8 317-4PB□□	2.8	13	4.4	0.75	1.23	3.4	3.3	79	93	3000 (2650)	100 (88)		Yes		
1PQ8 353-4PB□□	2.6	13	6.1	1.3	2.2	6.4	6.2	81	96	2500 (2350)	83 (78)	Yes	Yes		
1PQ8 355-4PB□□	2.6	13	6.8	1.3	2.2	6.4	6.2	81	96	2500 (2350)	83 (78)	Yes	Yes		
1PQ8 357-4PB□□	2.4	13	8.5	1.3	2.2	6.4	6.2	81	96	2500 (2350)	83 (78)	Yes			
1PQ8 403-4PB□□	2.7	13	13	1.6	2.8	6.4	6.2	83	98	2200 (2100)/2100 <sup>2)</sup>	73 (70)/70 <sup>2)</sup>	Yes			
1PQ8 405-4PB□□	2.7	13	14	1.6	2.8	6.4	6.2	83	98	2200 (2100)/2100 <sup>2)</sup>	73 (70)/70 <sup>2)</sup>	Yes	Yes		
1PQ8 407-4PB□□	2.7	13	16	1.6	2.8	6.4	6.2	83	98	2200 (2100)/2100 <sup>2)</sup>	73 (70)/70 <sup>2)</sup>		Yes		
1PQ8 453-4PC□□	2.6	10	23	3.0	4.2	8.2	7.7	86	101	2100 (1900)/1800 <sup>2)</sup>	70 (63)/60 <sup>2)</sup>		Yes		
1PQ8 455-4PC□□	2.6	10	26	3.0	4.2	8.2	7.7	86	101	2100 (1900)/1800 <sup>2)</sup>	70 (63)/60 <sup>2)</sup>		Yes Yes		
1PQ8 457-4PC□□	2.6	10	28	3.0	4.2	8.2	7.7	86	101	2100 (1900)/1800 <sup>2)</sup>	70 (63)/60 <sup>2)</sup>		Yes Yes		

Values in brackets apply to the use of motors in hazardous areas.

<sup>1)</sup> Limit speeds for reinforced bearings (order code **K20**) for 4-pole motors on request.

<sup>2)</sup> For vertical type of construction IM V1.

# IEC Squirrel-Cage Motors

## Non-standard motors frame size 315 and above

Forced-air cooled motors with separately driven fan for converter-fed operation – Cast-iron series 1PQ8

### Selection and ordering data (continued)

Rated output at		Frame size	Operating values at rated output and sinusoidal supply							Order No.	Price	Weight of IM B3 type of construction approx.
50 Hz	60 Hz		Rated speed at 50 Hz	Rated torque at 50 Hz	Efficiency at 50 Hz 4/4-load	Efficiency at 50 Hz 3/4-load	Power factor at 50 Hz 4/4-load	Rated current at 50 Hz 400 V	Rated current at 50 Hz 690 V			
$P_{rated}$ kW	$P_{rated}$ kW	FS	$n_{rated}$ rpm	$T_{rated}$ Nm	$\eta_{rated}$ %	$\eta_{rated}$ %	$\cos \varphi_{rated}$	$I_{rated}$ A	$I_{rated}$ A		$m$ kg	
<b>6-pole, 1000 rpm at 50 Hz, 1200 rpm at 60 Hz, temperature class 155 (F), used acc. to temperature class 155 (F), IP55 degree of protection, specially for operation on SINAMICS or SIMOVERT MASTERDRIVES with standard insulation for voltages ≤500 V</b>												
200	230	315	988	1930	95.7	95.8	0.86	345	200	1PQ8 315-6PB□□	1400	
250	288	315	988	2410	95.9	96.0	0.86	430	250	1PQ8 317-6PB□□	1600	
315	362	355	993	3040	96.2	96.2	0.86	540	315	1PQ8 355-6PB□□	2100	
400	460	355	993	3850	96.5	96.5	0.86	690	400	1PQ8 357-6PB□□	2300	
450	518	400	991	4330	96.5	96.5	0.86	780	455	1PQ8 403-6PB□□	2900	
500	575	400	991	4810	96.5	96.5	0.86	860	500	1PQ8 405-6PB□□	3100	
560	644	400	991	5390	96.7	96.7	0.86	960	460	1PQ8 407-6PB□□	3300	
630	725	450	993	6060	96.8	96.8	0.86	1100	630	1PQ8 453-6PB□□	4100	
710	817	450	993	6830	96.8	96.8	0.86	–	710 <sup>1)</sup>	1PQ8 455-6PB□□	4300	
800	920	450	993	7690	97.0	97.1	0.86	–	790 <sup>1)</sup>	1PQ8 457-6PB□□	4600	
<b>8-pole, 750 rpm at 50 Hz, 900 rpm at 60 Hz, temperature class 155 (F), used acc. to temperature class 155 (F), IP55 degree of protection, specially for operation on SINAMICS or SIMOVERT MASTERDRIVES with standard insulation for voltages ≤500 V</b>												
160	184	315	739	2070	94.9	94.9	0.82	295	172	1PQ8 315-8PB□□	1400	
200	230	315	739	2580	95.2	95.2	0.82	370	215	1PQ8 317-8PB□□	1600	
250	288	355	741	3220	95.7	95.7	0.82	460	265	1PQ8 355-8PB□□	2100	
315	362	355	741	4060	96.0	96.0	0.82	580	335	1PQ8 357-8PB□□	2300	
355	408	400	742	4570	96.1	96.1	0.82	650	375	1PQ8 403-8PB□□	2900	
400	460	400	742	5150	96.2	96.2	0.82	730	425	1PQ8 405-8PB□□	3100	
450	518	400	742	5790	96.3	96.3	0.82	820	475	1PQ8 407-8PB□□	3300	
500	575	450	744	6420	96.4	96.4	0.81	920	540	1PQ8 453-8PB□□	4100	
560	644	450	744	7190	96.5	96.5	0.81	1040	600	1PQ8 455-8PB□□	4300	
630	725	450	744	8090	96.6	96.6	0.81	1160	670	1PQ8 457-8PB□□	4600	

### Order No. supplements

Motor type	Penultimate position: Voltage code				Final position: Type of construction code			
	400 VΔ	400 VΔ/690 VY <sup>2)</sup>	500 VΔ	690 VΔ <sup>2)</sup>	Without flange IM B3	With flange IM V1 without protective cover <sup>3)</sup>	IM V1 with protective cover <sup>4)</sup>	IM B35
	4	8	5	7	0	8	4	6
<b>6-pole</b>								
1PQ8 315-...□□ to 1PQ8 453-...□□	○	□	○	–	□	✓	✓	✓
1PQ8 455-...□□ to 1PQ8 457-...□□	–	–	○	□	□	✓	✓	✓
<b>8-pole</b>								
1PQ8 315-...□□ to 1PQ8 457-...□□	○	□	○	– <sup>5)</sup>	□	✓	✓	✓

- Standard version
- Without additional charge
- ✓ With additional charge
- Not possible

Order other voltages with voltage code **9** in the penultimate position and the corresponding order code (see "Special versions" in the "Selection and ordering data" under "Voltages").

Voltages or frequencies that are not covered by the predefined options can be ordered with order code **L1Y**. In this case, the output, voltage and frequency must be specified.

- 1) Can also be supplied for 400 VΔ 50 Hz with voltage code **9** and order code **L1Y** (specify output, voltage and frequency).
- 2) Motors with standard insulation can only be operated with converter circuit (du/dt or sinusoidal filter).
- 3) For explosion-proof motors, the type of construction IM V1 without protective cover is not possible.

- 4) The "Second shaft extension" option, order code **K16** is not possible.
- 5) As special version with voltage code **9** and order code **L1Y** (specify output, voltage and frequency).

# IEC Squirrel-Cage Motors

## Non-standard motors frame size 315 and above

Forced-air cooled motors with separately driven fan  
for converter-fed operation – Cast-iron series 1PQ8

### Selection and ordering data (continued)

Order No.	Breakdown torque at 50 Hz as multiple of rated torque	Torque class	Moment of inertia	Technical data of the separately driven fan				Measuring surface sound pressure level at 50 Hz	Sound power level at 50 Hz	Mech. limit speed <sup>1)</sup>	Parallel feeders required		
				Power consumption with		Rated current at					For rated output, 50 Hz, tolerance +3 dB(A)	L <sub>pfA</sub> dB(A)	L <sub>WA</sub> dB(A)
T <sub>B</sub> /T <sub>rated</sub>	CL	J kgm <sup>2</sup>	P kW	P kW	I A	I A	50 Hz	60 Hz	400 V	460 V			
<b>6-pole, 1000 rpm at 50 Hz, 1200 rpm at 60 Hz, temperature class 155 (F), used acc. to temperature class 155 (F), IP55 degree of protection, specially for operation on SINAMICS or SIMOVERT MASTERDRIVES with standard insulation for voltages ≤500 V</b>													
<b>1PQ8 315-6PB□□</b>	2.5	13	6.0	0.75	1.23	3.4	3.3	80	94	2950 (2350)	147 (117)		
<b>1PQ8 317-6PB□□</b>	2.5	13	7.3	0.75	1.23	3.4	3.3	80	94	2950 (2350)	147 (117)	Yes	
<b>1PQ8 355-6PB□□</b>	2.8	13	13	1.3	2.2	6.4	6.2	82	97	2500 (2100)	125 (105)	Yes	
<b>1PQ8 357-6PB□□</b>	2.8	13	16	1.3	2.2	6.4	6.2	82	97	2500 (2100)	125 (105)	Yes	Yes
<b>1PQ8 403-6PB□□</b>	2.8	13	21	1.3	2.2	6.4	6.2	84	99	2200 (1900)/2100 <sup>2)</sup>	110 (95)/105 <sup>2)</sup>		
<b>1PQ8 405-6PB□□</b>	2.8	13	24	1.6	2.8	6.4	6.2	84	99	2200 (1900)/2100 <sup>2)</sup>	110 (95)/105 <sup>2)</sup>	Yes	
<b>1PQ8 407-6PB□□</b>	2.8	13	27	1.6	2.8	6.4	6.2	84	99	2200 (1900)/2100 <sup>2)</sup>	110 (95)/105 <sup>2)</sup>	Yes	
<b>1PQ8 453-6PB□□</b>	2.6	13	35	3.0	4.2	8.2	7.7	87	102	2100 (1700)/1800 <sup>2)</sup>	105 (85)/90 <sup>2)</sup>	Yes	Yes
<b>1PQ8 455-6PB□□</b>	2.5	13	39	3.0	4.2	8.2	7.7	87	102	2100 (1700)/1800 <sup>2)</sup>	105 (85)/90 <sup>2)</sup>	Yes	
<b>1PQ8 457-6PB□□</b>	2.5	13	44	3.0	4.2	8.2	7.7	87	102	2100 (1700)/1800 <sup>2)</sup>	105 (85)/90 <sup>2)</sup>	Yes	
<b>8-pole, 750 rpm at 50 Hz, 900 rpm at 60 Hz, temperature class 155 (F), used acc. to temperature class 155 (F), IP55 degree of protection, specially for operation on SINAMICS or SIMOVERT MASTERDRIVES with standard insulation for voltages ≤500 V</b>													
<b>1PQ8 315-8PB□□</b>	2.3	13	6.0	0.75	1.23	3.4	3.3	79	93	2950 (2350)	196 (156)		
<b>1PQ8 317-8PB□□</b>	2.3	13	7.3	0.75	1.23	3.4	3.3	79	93	2950 (2350)	196 (156)		
<b>1PQ8 355-8PB□□</b>	2.4	13	13	1.3	2.2	6.4	6.2	81	96	2500 (2100)	166 (140)		
<b>1PQ8 357-8PB□□</b>	2.4	13	16	1.3	2.2	6.4	6.2	81	96	2500 (2100)	166 (140)	Yes	
<b>1PQ8 403-8PB□□</b>	2.6	13	21	1.3	2.2	6.4	6.2	83	98	2200 (1900)/2100 <sup>2)</sup>	146 (126)/140 <sup>2)</sup>		
<b>1PQ8 405-8PB□□</b>	2.6	13	24	1.6	2.8	6.4	6.2	83	98	2200 (1900)/2100 <sup>2)</sup>	146 (126)/140 <sup>2)</sup>	Yes	
<b>1PQ8 407-8PB□□</b>	2.6	13	27	1.6	2.8	6.4	6.2	83	98	2200 (1900)/2100 <sup>2)</sup>	146 (126)/140 <sup>2)</sup>	Yes	
<b>1PQ8 453-8PB□□</b>	2.4	13	35	3.0	4.2	8.2	7.7	86	101	2100 (1700)/1800 <sup>2)</sup>	140 (113)/120 <sup>2)</sup>	Yes	
<b>1PQ8 455-8PB□□</b>	2.4	13	39	3.0	4.2	8.2	7.7	86	101	2100 (1700)/1800 <sup>2)</sup>	141 (113)/120 <sup>2)</sup>	Yes	Yes
<b>1PQ8 457-8PB□□</b>	2.4	13	44	3.0	4.2	8.2	7.7	86	101	2100 (1700)/1800 <sup>2)</sup>	142 (113)/120 <sup>2)</sup>	Yes	Yes

Values in brackets apply to the use of motors in hazardous areas.

<sup>1)</sup> Limit speeds for reinforced bearings (order code **K20**) for 6- and 8-pole motors on request.

<sup>2)</sup> For vertical type of construction IM V1.

# IEC Squirrel-Cage Motors

## Non-standard motors frame size 315 and above

Forced-air cooled motors with separately driven fan for converter-fed operation – Cast-iron series 1PQ8

### Selection and ordering data (continued)

Rated output at		Frame size	Operating values at rated output and sinusoidal supply						Rated current at 50 Hz 690 V	Order No. For Order No. supplements for voltage and type of construction, see table below	Price	Weight of IM B3 type of construction approx.
50 Hz	60 Hz		Rated speed at 50 Hz	Rated torque at 50 Hz	Efficiency at 50 Hz 4/4-load	Efficiency at 50 Hz 3/4-load	Power factor at 50 Hz 4/4-load					
$P_{rated}$ kW	$P_{rated}$ kW	FS	$n_{rated}$ rpm	$T_{rated}$ Nm	$\eta_{rated}$ %	$\eta_{rated}$ %	$\cos\phi_{rated}$	$I_{rated}$ A			$m$ kg	
<b>2-pole, 3000 rpm at 50 Hz, 3600 rpm at 60 Hz, temperature class 155 (F), used acc. to temperature class 155 (F), IP55 degree of protection, specially for operation on SINAMICS or SIMOVERT MASTERDRIVES with special insulation for voltages &gt;500 to 690 V</b>												
240	270	315	2978	770	96.0	96.0	0.90	230	<b>1PQ8 315-2PM8□</b>		1400	
300	335	315	2978	962	96.4	96.4	0.91	285	<b>1PQ8 317-2PM8□</b>		1600	
345	385	355	2981	1105	96.4	96.4	0.90	335	<b>1PQ8 353-2PM8□</b>		2000	
390	435	355	2981	1249	96.6	96.6	0.91	370	<b>1PQ8 355-2PM8□</b>		2100	
485	545	355	2982	1553	97.0	97.0	0.91	460	<b>1PQ8 357-2PM8□</b>		2300	
545	600	400	2986	1743	97.1	97.1	0.91	520	<b>1PQ8 403-2PM7□</b>		2900	
610	670	400	2986	1951	97.1	97.1	0.91	580	<b>1PQ8 405-2PM7□</b>		3100	
680	750	400	2986	2175	97.2	97.2	0.92	640	<b>1PQ8 407-2PM7□</b>		3300	
775	-	450	2987	2478	97.2	97.2	0.92	730	<b>1PQ8 453-2PM7□</b>		4100	
875	-	450	2987	2798	97.3	97.3	0.92	820	<b>1PQ8 455-2PM7□</b>		4300	
970	-	450	2987	3101	97.4	97.4	0.93	900	<b>1PQ8 457-2PM7□</b>		4500	
<b>4-pole, 1500 rpm at 50 Hz, 1800 rpm at 60 Hz, temperature class 155 (F), used acc. to temperature class 155 (F), IP55 degree of protection, specially for operation on SINAMICS or SIMOVERT MASTERDRIVES with special insulation for voltages &gt;500 to 690 V</b>												
235	270	315	1485	1511	95.8	95.8	0.87	235	<b>1PQ8 315-4PM8□</b>		1400	
290	335	315	1485	1865	95.9	95.9	0.87	285	<b>1PQ8 317-4PM8□</b>		1600	
340	390	355	1488	2182	96.0	96.0	0.87	340	<b>1PQ8 353-4PM8□</b>		2000	
385	445	355	1488	2471	96.2	96.2	0.87	385	<b>1PQ8 355-4PM8□</b>		2100	
480	550	355	1488	3081	96.4	96.4	0.87	480	<b>1PQ8 357-4PM8□</b>		2300	
545	625	400	1491	3491	96.5	96.5	0.88	540	<b>1PQ8 403-4PM8□</b>		2900	
615	710	400	1491	3939	96.7	96.7	0.88	600	<b>1PQ8 405-4PM8□</b>		3100	
690	795	400	1491	4420	96.9	96.9	0.89	670	<b>1PQ8 407-4PM7□</b>		3300	
785	905	450	1492	5025	96.8	96.8	0.88	770	<b>1PQ8 453-4PM7□</b>		4100	
880	1010	450	1492	5633	97.0	97.0	0.87	870	<b>1PQ8 455-4PM7□</b>		4300	
980	1125	450	1492	6273	97.1	97.1	0.89	950	<b>1PQ8 457-4PM7□</b>		4500	

### Order No. supplements

Motor type	Final position: Type of construction code			
	Without flange IM B3	With flange		
		IM V1 without protective cover	IM V1 with protective cover	IM B35
	<b>0</b>	<b>8</b>	<b>4</b>	<b>6</b>
<b>1PQ8 315- . . . □□</b> to <b>1PQ8 457- . . . □□</b>	□	✓	✓	✓

- Standard version
- ✓ With additional charge

The voltage code is already in the Order No. as the penultimate position.

Assignment:

**7** = 690 VΔ

**8** = 400 VΔ/690 VY

Order other voltages with voltage code **9** in the penultimate position and the corresponding order code (see "Special versions" in the "Selection and ordering data" under "Voltages").

Voltages or frequencies that are not covered by the predefined options can be ordered with order code **L1Y**. In this case, the output, voltage and frequency must be specified.

# IEC Squirrel-Cage Motors

## Non-standard motors frame size 315 and above

Forced-air cooled motors with separately driven fan  
for converter-fed operation – Cast-iron series 1PQ8

### Selection and ordering data (continued)

Order No.	Breakdown torque at 50 Hz as multiple of rated torque	Torque class	Moment of inertia	Technical data of the separately driven fan				Measuring surface sound pressure level at 50 Hz	Sound power level at 50 Hz	Mech. limit speed <sup>1)</sup>	Parallel feeders required				
				Power consumption with	Rated current at	50 Hz	60 Hz				400 V	460 V	50 Hz	60 Hz	For rated output, 50 Hz, tolerance +3 dB(A)
	$T_B/T_{rated}$	CL	$J$ kgm <sup>2</sup>	$P$ kW	$P$ kW	$I$ A	$I$ A	$L_{pA}$ dB(A)	$L_{WA}$ dB(A)	$\eta_{max}$ rpm	$f_{max}$ Hz				
<b>2-pole, 3000 rpm at 50 Hz, 3600 rpm at 60 Hz, temperature class 155 (F), used acc. to temperature class 155 (F), IP55 degree of protection, specially for operation on SINAMICS or SIMOVERT MASTERDRIVES with special insulation for voltages &gt;500 to 690 V</b>															
<b>1PQ8 315-2PM8□</b>	3.0	10	2.7	0.75	1.23	3.4	3.3	79	94	3600	60	Yes	Yes		
<b>1PQ8 317-2PM8□</b>	3.0	10	3.3	0.75	1.23	3.4	3.3	79		3600	60	Yes	Yes		
<b>1PQ8 353-2PM8□</b>	2.6	10	4.8	1.3	2.2	6.4	6.2	81	96	3600/3100 <sup>2)</sup>	60/52 <sup>2)</sup>	Yes	Yes		
<b>1PQ8 355-2PM8□</b>	2.6	10	5.3	1.3	2.2	6.4	6.2	81		3600/3100 <sup>2)</sup>	60/52 <sup>2)</sup>	Yes	Yes		
<b>1PQ8 357-2PM8□</b>	2.6	10	6.4	1.3	2.2	6.4	6.2	81		3600/3100 <sup>2)</sup>	60/52 <sup>2)</sup>	Yes			
<b>1PQ8 403-2PM7□</b>	3.0	10	8.6	1.6	2.8	6.4	6.2	83	98	3600/3100 <sup>2)</sup>	60/52 <sup>2)</sup>	Yes			
<b>1PQ8 405-2PM7□</b>	3.1	10	9.6	1.6	2.8	6.4	6.2	83		3600/3100 <sup>2)</sup>	60/52 <sup>2)</sup>	Yes	Yes		
<b>1PQ8 407-2PM7□</b>	3.0	10	11	1.6	2.8	6.4	6.2	83		3600/3100 <sup>2)</sup>	60/52 <sup>2)</sup>	Yes			
<b>1PQ8 453-2PM7□</b>	2.8	5	19	3.0	4.2	8.2	7.7	86	101	3000	50	Yes			
<b>1PQ8 455-2PM7□</b>	2.8	5	21	3.0	4.2	8.2	7.7	86		3000	50	Yes	Yes		
<b>1PQ8 457-2PM7□</b>	2.8	5	23	3.0	4.2	8.2	7.7	86		3000	50	Yes	Yes		
<b>4-pole, 1500 rpm at 50 Hz, 1800 rpm at 60 Hz, temperature class 155 (F), used acc. to temperature class 155 (F), IP55 degree of protection, specially for operation on SINAMICS or SIMOVERT MASTERDRIVES with special insulation for voltages &gt;500 to 690 V</b>															
<b>1PQ8 315-4PM8□</b>	2.8	13	3.6	0.75	1.23	3.4	3.3	79	93	3000 (2650)	100 (88)	Yes			
<b>1PQ8 317-4PM8□</b>	2.8	13	4.4	0.75	1.23	3.4	3.3	79		3000 (2650)	100 (88)	Yes			
<b>1PQ8 353-4PM8□</b>	2.6	13	6.1	1.3	2.2	6.4	6.2	81	96	2500 (2350)	83 (78)	Yes	Yes		
<b>1PQ8 355-4PM8□</b>	2.6	13	6.8	1.3	2.2	6.4	6.2	81		2500 (2350)	83 (78)	Yes	Yes		
<b>1PQ8 357-4PM8□</b>	2.5	13	8.5	1.3	2.2	6.4	6.2	81		2500 (2350)	83 (78)	Yes			
<b>1PQ8 403-4PM8□</b>	2.6	13	13	1.6	2.8	6.4	6.2	83	98	2200 (2100)/2100 <sup>2)</sup>	73 (70)/70 <sup>2)</sup>	Yes			
<b>1PQ8 405-4PM8□</b>	2.7	13	14	1.6	2.8	6.4	6.2	83		2200 (2100)/2100 <sup>2)</sup>	73 (70)/70 <sup>2)</sup>	Yes	Yes		
<b>1PQ8 407-4PM7□</b>	2.6	13	16	1.6	2.8	6.4	6.2	83		2200 (2100)/2100 <sup>2)</sup>	73 (70)/70 <sup>2)</sup>	Yes			
<b>1PQ8 453-4PM7□</b>	2.5	10	23	3.0	4.2	8.2	7.7	86	101	2100 (1900)/1800 <sup>2)</sup>	70 (61)/60 <sup>2)</sup>	Yes			
<b>1PQ8 455-4PM7□</b>	2.6	10	26	3.0	4.2	8.2	7.7	86		2100 (1900)/1800 <sup>2)</sup>	70 (61)/60 <sup>2)</sup>	Yes	Yes		
<b>1PQ8 457-4PM7□</b>	2.6	10	28	3.0	4.2	8.2	7.7	86		2100 (1900)/1800 <sup>2)</sup>	70 (61)/60 <sup>2)</sup>	Yes	Yes		

Values in brackets apply to the use of motors in hazardous areas.

<sup>1)</sup> Limit speeds for reinforced bearings (order code **K20**) for 4-pole motors on request.

<sup>2)</sup> For vertical type of construction IM V1.

# IEC Squirrel-Cage Motors

## Non-standard motors frame size 315 and above

Forced-air cooled motors with separately driven fan  
for converter-fed operation – Cast-iron series 1PQ8

### Selection and ordering data (continued)

Rated output at		Frame size	Operating values at rated output and sinusoidal supply						Order No.	Price	Weight of IM B3 type of construction approx.
50 Hz	60 Hz		Rated speed at 50 Hz	Rated torque at 50 Hz	Efficiency at 50 Hz 4/4-load	Efficiency at 50 Hz 3/4-load	Power factor at 50 Hz 4/4-load	Rated current at 50 Hz 690 V			
$P_{rated}$ kW	$P_{rated}$ kW	FS	$n_{rated}$ rpm	$T_{rated}$ Nm	$\eta_{rated}$ %	$\eta_{rated}$ %	$\cos\phi_{rated}$	$I_{rated}$ A		$m$ kg	
<b>6-pole, 1000 rpm at 50 Hz, 1200 rpm at 60 Hz, temperature class 155 (F), used acc. to temperature class 155 (F), IP55 degree of protection, specially for operation on SINAMICS or SIMOVERT MASTERDRIVES with special insulation for voltages &gt;500 to 690 V</b>											
190	220	315	990	1833	95.5	95.6	0.85	196	<b>1PQ8 315-6PM8□</b>	1400	
235	270	315	990	2267	95.7	95.8	0.86	240	<b>1PQ8 317-6PM8□</b>	1600	
300	345	355	992	2888	96.2	96.2	0.86	305	<b>1PQ8 355-6PM8□</b>	2100	
380	435	355	992	3658	96.4	96.4	0.86	385	<b>1PQ8 357-6PM8□</b>	2300	
435	500	400	993	4184	96.4	96.4	0.85	445	<b>1PQ8 403-6PM8□</b>	2900	
485	560	400	993	4664	96.5	96.5	0.86	490	<b>1PQ8 405-6PM8□</b>	3100	
545	625	400	993	5241	96.6	96.6	0.86	550	<b>1PQ8 407-6PM8□</b>	3300	
615	705	450	993	5915	96.8	96.8	0.84	630	<b>1PQ8 453-6PM8□</b>	4100	
690	795	450	993	6636	96.8	96.8	0.85	700	<b>1PQ8 455-6PM7□</b>	4300	
780	895	450	993	7502	96.9	97.0	0.85	790	<b>1PQ8 457-6PM7□</b>	4600	
<b>8-pole, 750 rpm at 50 Hz, 900 rpm at 60 Hz, temperature class 155 (F), used acc. to temperature class 155 (F), IP55 degree of protection, specially for operation on SINAMICS or SIMOVERT MASTERDRIVES with special insulation for voltages &gt;500 to 690 V</b>											
145	165	315	740	1871	94.6	94.6	0.79	162	<b>1PQ8 315-8PM8□</b>	1400	
180	205	315	740	2323	94.9	94.9	0.80	198	<b>1PQ8 317-8PM8□</b>	1600	
230	265	355	743	2956	95.5	95.5	0.80	250	<b>1PQ8 355-8PM8□</b>	2100	
290	335	355	743	3727	95.7	95.7	0.81	315	<b>1PQ8 357-8PM8□</b>	2300	
335	385	400	743	4306	96.0	96.0	0.80	365	<b>1PQ8 403-8PM8□</b>	2900	
375	430	400	743	4820	96.1	96.1	0.80	410	<b>1PQ8 405-8PM8□</b>	3100	
425	490	400	743	5463	96.2	96.2	0.79	470	<b>1PQ8 407-8PM8□</b>	3300	
485	560	450	745	6217	96.5	96.5	0.78	540	<b>1PQ8 453-8PM8□</b>	4100	
545	625	450	745	6986	96.6	96.6	0.78	610	<b>1PQ8 455-8PM8□</b>	4300	
600	690	450	745	7691	96.7	96.7	0.79	660	<b>1PQ8 457-8PM8□</b>	4600	

### Order No. supplements

Motor type	Final position: Type of construction code			
	Without flange	With flange		
	IM B3	IM V1 without protective cover	IM V1 with protective cover	IM B35
	<b>0</b>	<b>8</b>	<b>4</b>	<b>6</b>
<b>1PQ8 315-...□□</b> to <b>1PQ8 457-...□□</b>	□	✓	✓	✓

- Standard version
- ✓ With additional charge

The voltage code is already in the Order No. as the penultimate position.

Assignment:

**7** = 690 VΔ

**8** = 400 VΔ/690 VY

Order other voltages with voltage code **9** in the penultimate position and the corresponding order code (see "Special versions" in the "Selection and ordering data" under "Voltages").

Voltages or frequencies that are not covered by the predefined options can be ordered with order code **L1Y**. In this case, the output, voltage and frequency must be specified.

# IEC Squirrel-Cage Motors

## Non-standard motors frame size 315 and above

Forced-air cooled motors with separately driven fan  
for converter-fed operation – Cast-iron series 1PQ8

### Selection and ordering data (continued)

Order No.	Breakdown torque at 50 Hz as multiple of rated torque	Torque class	Moment of inertia	Technical data of the separately driven fan				Measuring surface sound pressure level at 50 Hz	Sound power level at 50 Hz	Mech. limit speed <sup>1)</sup>			Parallel feeders required	
				Power consumption with	Rated current at		For rated output, 50 Hz, tolerance +3 dB(A)			$L_{pA}$ dB(A)	$L_{WA}$ dB(A)	$n_{max.}$ rpm		$f_{max.}$ Hz
$T_B/T_{rated}$	CL	$J$ kgm <sup>2</sup>	$P$ kW	$P$ kW	$I$ A	$I$ A		$L_{pA}$ dB(A)	$L_{WA}$ dB(A)				$n_{max.}$ rpm	
<b>6-pole, 1000 rpm at 50 Hz, 1200 rpm at 60 Hz, temperature class 155 (F), used acc. to temperature class 155 (F), IP55 degree of protection, specially for operation on SINAMICS or SIMOVERT MASTERDRIVES with special insulation for voltages &gt;500 to 690 V</b>														
<b>1PQ8 315-6PM8□</b>	2.7	13	6	0.75	1.23	3.4	3.3	80	94	2950 (2350)	147 (117)			
<b>1PQ8 317-6PM8□</b>	2.7	13	7.3	0.75	1.23	3.4	3.3	80	94	2950 (2350)	147 (117)	Yes		
<b>1PQ8 355-6PM8□</b>	2.8	13	13	1.3	2.2	6.4	6.2	82	97	2500 (2100)	125 (105)	Yes		
<b>1PQ8 357-6PM8□</b>	2.9	13	16	1.3	2.2	6.4	6.2	82	97	2500 (2100)	125 (105)	Yes	Yes	
<b>1PQ8 403-6PM8□</b>	2.8	13	21	1.3	2.2	6.4	6.2	84	99	2200 (1900)/2100 <sup>2)</sup>	110 (95)/105 <sup>2)</sup>			
<b>1PQ8 405-6PM8□</b>	2.8	13	24	1.6	2.8	6.4	6.2	84	99	2200 (1900)/2100 <sup>2)</sup>	110 (95)/105 <sup>2)</sup>	Yes		
<b>1PQ8 407-6PM8□</b>	2.7	13	27	1.6	2.8	6.4	6.2	84	99	2200 (1900)/2100 <sup>2)</sup>	110 (95)/105 <sup>2)</sup>	Yes		
<b>1PQ8 453-6PM8□</b>	2.7	13	35	1.6	2.8	6.4	6.2	87	102	2100 (1700)/1800 <sup>2)</sup>	105 (85)/90 <sup>2)</sup>	Yes	Yes	
<b>1PQ8 455-6PM7□</b>	2.5	13	39	3	4.2	8.2	7.7	87	102	2100 (1700)/1800 <sup>2)</sup>	105 (85)/90 <sup>2)</sup>		Yes	
<b>1PQ8 457-6PM7□</b>	2.6	13	44	3	4.2	8.2	7.7	87	102	2100 (1700)/1800 <sup>2)</sup>	105 (85)/90 <sup>2)</sup>		Yes	
<b>8-pole, 750 rpm at 50 Hz, 900 rpm at 60 Hz, temperature class 155 (F), used acc. to temperature class 155 (F), IP55 degree of protection, specially for operation on SINAMICS or SIMOVERT MASTERDRIVES with special insulation for voltages &gt;500 to 690 V</b>														
<b>1PQ8 315-8PM8□</b>	2.5	13	6	0.75	1.23	3.4	3.3	79	93	2950 (2350)	196 (156)			
<b>1PQ8 317-8PM8□</b>	2.5	13	7.3	0.75	1.23	3.4	3.3	79	93	2950 (2350)	196 (156)			
<b>1PQ8 355-8PM8□</b>	2.4	13	13	1.3	2.2	6.4	6.2	81	96	2500 (2100)	166 (140)			
<b>1PQ8 357-8PM8□</b>	2.4	13	16	1.3	2.2	6.4	6.2	81	96	2500 (2100)	166 (140)	Yes		
<b>1PQ8 403-8PM8□</b>	2.6	13	21	1.3	2.2	6.4	6.2	83	98	2200 (1900)/2100 <sup>2)</sup>	146 (126)/140 <sup>2)</sup>			
<b>1PQ8 405-8PM8□</b>	2.7	13	24	1.6	2.8	6.4	6.2	83	98	2200 (1900)/2100 <sup>2)</sup>	146 (126)/140 <sup>2)</sup>	Yes		
<b>1PQ8 407-8PM8□</b>	2.7	13	27	1.6	2.8	6.4	6.2	83	98	2200 (1900)/2100 <sup>2)</sup>	146 (126)/140 <sup>2)</sup>	Yes		
<b>1PQ8 453-8PM8□</b>	2.5	13	35	1.6	2.8	6.4	6.2	86	101	2100 (1700)/1800 <sup>2)</sup>	140 (113)/120 <sup>2)</sup>	Yes		
<b>1PQ8 455-8PM8□</b>	2.5	13	39	3	4.2	8.2	7.7	86	101	2100 (1700)/1800 <sup>2)</sup>	140 (113)/120 <sup>2)</sup>	Yes	Yes	
<b>1PQ8 457-8PM8□</b>	2.5	13	44	3	4.2	8.2	7.7	86	101	2100 (1700)/1800 <sup>2)</sup>	140 (113)/120 <sup>2)</sup>	Yes	Yes	

Values in brackets apply to the use of motors in hazardous areas.

<sup>1)</sup> Limit speeds for reinforced bearings (order code **K20**) for 6- and 8-pole motors on request.

<sup>2)</sup> For vertical type of construction IM V1.

# IEC Squirrel-Cage Motors

## Non-standard motors frame size 315 and above

Self-ventilated motors with through ventilation  
for mains-fed operation – Cast-iron series 1LL8

### Selection and ordering data

Rated output at		Frame size	Operating values at rated output						Order No.	Price	Weight of IM B3 type of construction approx.
50 Hz	60 Hz		Rated speed at 50 Hz	Rated torque at 50 Hz	Efficiency at 50 Hz 4/4-load	Power factor at 50 Hz 4/4-load	Rated current at 50 Hz 400 V	Rated current at 50 Hz 690 V			
$P_{rated}$ kW	$P_{rated}$ kW	FS	$n_{rated}$ rpm	$T_{rated}$ Nm	$\eta_{rated}$ %	$\cos\phi_{rated}$	$I_{rated}$ A	$I_{rated}$ A		$m$ kg	
<b>2-pole, 3000 rpm at 50 Hz, 3600 rpm at 60 Hz, temperature class 155 (F), used acc. to temperature class 130 (B), IP23 degree of protection</b>											
315	345	315	2974	1010	96.1	0.92	510	300	<b>1LL8 315-2AC□□</b>	1300	
400	440	315	2974	1280	96.4	0.92	650	375	<b>1LL8 317-2AC□□</b>	1500	
450	–	355	2978	1440	96.4	0.91	740	430	<b>1LL8 353-2AD□□</b>	1900	
500	–	355	2979	1600	96.6	0.92	810	470	<b>1LL8 355-2AD□□</b>	2000	
630	–	355	2980	2020	96.9	0.93	1000	580	<b>1LL8 357-2AD□□</b>	2200	
710	–	400	2984	2270	97.0	0.91	1160	670	<b>1LL8 403-2AD□□</b>	2800	
800	–	400	2984	2560	97.1	0.92	1300	750	<b>1LL8 405-2AD□□</b>	3000	
900	–	400	2985	2880	97.3	0.92	–	840	<b>1LL8 407-2AD□□</b>	3200	
1000	–	450	2987	3200	97.3	0.93	–	920	<b>1LL8 453-2AE□□</b>	4000	
1120	–	450	2986	3580	97.3	0.94	–	1020	<b>1LL8 455-2AE□□</b>	4200	
1250	–	450	2986	4000	97.4	0.94	–	1140	<b>1LL8 457-2AE□□</b>	4400	
<b>4-pole, 1500 rpm at 50 Hz, 1800 rpm at 60 Hz, temperature class 155 (F), used acc. to temperature class 130 (B), IP23 degree of protection</b>											
315	360	315	1483	2030	96.0	0.87	540	315	<b>1LL8 315-4AC□□</b>	1300	
400	460	315	1484	2570	96.2	0.88	680	395	<b>1LL8 317-4AC□□</b>	1500	
450	515	355	1487	2890	96.5	0.87	770	450	<b>1LL8 353-4AC□□</b>	1900	
500	575	355	1487	3210	96.6	0.88	850	490	<b>1LL8 355-4AC□□</b>	2000	
630	725	355	1488	4040	96.9	0.88	1060	620	<b>1LL8 357-4AC□□</b>	2200	
710	815	400	1489	4550	96.9	0.88	1200	700	<b>1LL8 403-4AC□□</b>	2800	
800	920	400	1490	5130	97.0	0.88	–	780	<b>1LL8 405-4AC□□</b>	3000	
900	1035	400	1491	5760	97.2	0.87	–	890	<b>1LL8 407-4AC□□</b>	3200	
1000	1150	450	1492	6400	97.2	0.86	–	1000	<b>1LL8 453-4AD□□</b>	4000	
1120	1280	450	1491	7170	97.2	0.89	–	1080	<b>1LL8 455-4AD□□</b>	4200	
1250	1430	450	1490	8010	97.2	0.89	–	1200	<b>1LL8 457-4AD□□</b>	4400	

A service factor (SF) of 1.05 is stamped onto all 1LL8 motors for mains-fed operation.

### Order No. supplements

Motor type	Penultimate position: Voltage code				Final position: Type of construction code			
	400 VΔ/690 VY	500 VΔ	690 VΔ	60 Hz 460 VΔ (see "Introduction" for outputs at 60 Hz)	Without flange IM B3	With flange		IM B35
						IM V1 without protective cover	IM V1 with protective cover <sup>1)</sup>	
	<b>6</b>	<b>5</b>	<b>0</b>	<b>9 L2F</b>	<b>0</b>	<b>8</b>	<b>4</b>	<b>6</b>
<b>1LL8 315-...□□</b> to <b>1LL8 317-...□□</b>	□	○	– <sup>2)</sup>	○	□	✓	✓	✓
<b>1LL8 353-...□□</b> to <b>1LL8 405-...□□</b>	□	○	– <sup>2)</sup>	○	□ <sup>3)</sup>	✓ <sup>3)</sup>	✓ <sup>3)</sup>	✓ <sup>3)</sup>
<b>1LL8 407-...□□</b> to <b>1LL8 457-...□□</b>	–	○	□	O. R.	□ <sup>3)</sup>	✓ <sup>3)</sup>	✓ <sup>3)</sup>	✓ <sup>3)</sup>

- Standard version
- Without additional charge
- ✓ With additional charge
- O. R. Possible on request
- Not possible

Order other voltages with voltage code **9** in the penultimate position and the corresponding order code (see "Special versions" in the "Selection and ordering data" under "Voltages").

Voltages or frequencies that are not covered by the predefined options can be ordered with order code **L1Y**. In this case, the output, voltage and frequency must be specified.

- 1) The "Second shaft extension" option, order code **K16** is not possible.
- 2) As special version with voltage code **9** and order code **L1Y** (specify output, voltage and frequency).
- 3) Not possible for 2-pole motors in 60 Hz version.



# IEC Squirrel-Cage Motors

## Non-standard motors frame size 315 and above

Self-ventilated motors with through ventilation  
for mains-fed operation – Cast-iron series 1LL8

### Selection and ordering data (continued)

Order No.	Locked-rotor torque	Locked-rotor current	Break-down torque	Torque class	Moment of inertia	Noise at rated output		Mech. limit speed	Parallel feeders required		
	At 50 Hz and for direct online starting as multiple of rated torque	At 50 Hz and for direct online starting as multiple of rated current	At 50 Hz and for direct online starting as multiple of rated torque	CL	$J$ kgm <sup>2</sup>	Measuring surface sound pressure level at 50 Hz	Sound power level at 50 Hz		$\eta_{\max}$ rpm	400 V	500 V
	$T_{LR}/T_{rated}$	$I_{LR}/I_{rated}$	$T_B/T_{rated}$			$L_{pA}$ dB(A)	$L_{WA}$ dB(A)				
<b>2-pole, 3000 rpm at 50 Hz, 3600 rpm at 60 Hz, temperature class 155 (F), used acc. to temperature class 130 (B), IP23 degree of protection</b>											
<b>1LL8 315-2AC□□</b>	1.6	7.0	2.8	10	2.7	84 <sup>1)</sup>	99	3600	Yes		
<b>1LL8 317-2AC□□</b>	1.7	7.0	2.8	10	3.3	84 <sup>1)</sup>	99	3600	Yes		
<b>1LL8 353-2AD□□</b>	1.4	7.0	2.6	7	4.8	86 <sup>1)</sup>	101	3600/3100 <sup>2)</sup>	Yes	Yes	
<b>1LL8 355-2AD□□</b>	1.4	7.0	2.6	7	5.3	86 <sup>1)</sup>	101	3600/3100 <sup>2)</sup>	Yes	Yes	
<b>1LL8 357-2AD□□</b>	1.6	7.0	2.6	7	6.4	86 <sup>1)</sup>	101	3600/3100 <sup>2)</sup>	Yes		
<b>1LL8 403-2AD□□</b>	1.4	6.8	2.6	7	8.6	88 <sup>1)</sup>	103	3600/3100 <sup>2)</sup>	Yes		
<b>1LL8 405-2AD□□</b>	1.5	7.0	2.6	7	9.6	88 <sup>1)</sup>	103	3600/3100 <sup>2)</sup>	Yes	Yes	
<b>1LL8 407-2AD□□</b>	1.5	7.0	2.7	7	11	88 <sup>1)</sup>	103	3600/3100 <sup>2)</sup>	Yes		
<b>1LL8 453-2AE□□</b>	0.9	7.0	2.9	5	19	90 <sup>1)</sup>	105	3000	Yes		
<b>1LL8 455-2AE□□</b>	0.9	7.0	2.7	5	21	90 <sup>1)</sup>	105	3000	Yes	Yes	
<b>1LL8 457-2AE□□</b>	0.9	7.0	2.6	5	23	90 <sup>1)</sup>	105	3000	Yes	Yes	
<b>4-pole, 1500 rpm at 50 Hz, 1800 rpm at 60 Hz, temperature class 155 (F), used acc. to temperature class 130 (B), IP23 degree of protection</b>											
<b>1LL8 315-4AC□□</b>	1.6	7.0	2.7	10	3.6	75	90	3000/2600 <sup>2)</sup>	Yes		
<b>1LL8 317-4AC□□</b>	1.7	7.0	2.7	10	4.4	75	90	3000/2600 <sup>2)</sup>	Yes		
<b>1LL8 353-4AC□□</b>	1.5	7.0	2.6	10	6.1	77	92	2500/2200 <sup>2)</sup>	Yes	Yes	
<b>1LL8 355-4AC□□</b>	1.6	7.0	2.6	10	6.8	77	92	2500/2200 <sup>2)</sup>	Yes	Yes	
<b>1LL8 357-4AC□□</b>	1.6	7.0	2.7	10	8.5	77	92	2500/2200 <sup>2)</sup>	Yes		
<b>1LL8 403-4AC□□</b>	1.6	7.0	2.4	10	13	81	96	2200/1900 <sup>2)</sup>	Yes		
<b>1LL8 405-4AC□□</b>	1.7	7.0	2.5	10	14	81	96	2200/1900 <sup>2)</sup>	Yes	Yes	
<b>1LL8 407-4AC□□</b>	1.7	7.0	2.6	10	16	81	96	2200/1900 <sup>2)</sup>	Yes		
<b>1LL8 453-4AD□□</b>	1.5	7.0	2.8	7	23	84	99	2100/1800 <sup>2)</sup>	Yes		
<b>1LL8 455-4AD□□</b>	1.5	7.0	2.6	7	26	84	99	2100/1800 <sup>2)</sup>	Yes	Yes	
<b>1LL8 457-4AD□□</b>	1.5	7.0	2.5	7	28	84	99	2100/1800 <sup>2)</sup>	Yes	Yes	

<sup>1)</sup> The noise values for **1LL8**, 2-pole are for guidance only.

<sup>2)</sup> For vertical type of construction IM V1.

# IEC Squirrel-Cage Motors

## Non-standard motors frame size 315 and above

Self-ventilated motors with through ventilation  
for mains-fed operation – Cast-iron series 1LL8

### Selection and ordering data (continued)

Rated output at		Frame size	Operating values at rated output						Order No.	Price	Weight of IM B3 type of construction approx.
50 Hz	60 Hz		Rated speed at 50 Hz	Rated torque at 50 Hz	Efficiency at 50 Hz 4/4-load	Power factor at 50 Hz 4/4-load	Rated current at 50 Hz 400 V	Rated current at 50 Hz 690 V			
$P_{\text{rated}}$ kW	$P_{\text{rated}}$ kW	FS	$n_{\text{rated}}$ rpm	$T_{\text{rated}}$ Nm	$\eta_{\text{rated}}$ %	$\cos\phi_{\text{rated}}$	$I_{\text{rated}}$ A	$I_{\text{rated}}$ A		$m$ kg	
<b>6-pole, 1000 rpm at 50 Hz, 1200 rpm at 60 Hz, temperature class 155 (F), used acc. to temperature class 130 (B), IP23 degree of protection</b>											
250	285	315	988	2420	95.4	0.88	430	250	<b>1LL8 315-6AC□□</b>	1300	
315	360	315	988	3040	95.7	0.89	530	310	<b>1LL8 317-6AC□□</b>	1500	
400	460	355	991	3850	96.1	0.88	680	395	<b>1LL8 355-6AC□□</b>	2000	
500	575	355	991	4820	96.4	0.88	850	495	<b>1LL8 357-6AC□□</b>	2200	
560	645	400	993	5390	96.6	0.87	960	560	<b>1LL8 403-6AC□□</b>	2800	
630	725	400	993	6060	96.7	0.88	1060	620	<b>1LL8 405-6AC□□</b>	3000	
710	815	400	993	6830	96.7	0.88	1200	700	<b>1LL8 407-6AC□□</b>	3200	
800	920	450	993	7700	96.8	0.87	–	790	<b>1LL8 453-6AD□□</b>	4000	
900	1035	450	992	8660	96.8	0.88	–	880	<b>1LL8 455-6AD□□</b>	4200	
1000	1150	450	993	9620	96.9	0.88	–	980	<b>1LL8 457-6AD□□</b>	4500	
<b>8-pole, 750 rpm at 50 Hz, 900 rpm at 60 Hz, temperature class 155 (F), used acc. to temperature class 130 (B), IP23 degree of protection</b>											
200	230	315	738	2590	94.7	0.82	370	215	<b>1LL8 315-8AC□□</b>	1300	
250	285	315	738	3240	95.0	0.82	465	270	<b>1LL8 317-8AC□□</b>	1500	
315	360	355	740	4070	95.5	0.83	570	335	<b>1LL8 355-8AC□□</b>	2000	
400	460	355	740	5160	95.6	0.84	720	415	<b>1LL8 357-8AC□□</b>	2200	
450	515	400	741	5800	95.9	0.84	810	465	<b>1LL8 403-8AD□□</b>	2800	
500	575	400	741	6440	96.1	0.84	890	520	<b>1LL8 405-8AD□□</b>	3000	
560	645	400	742	7210	96.2	0.83	1020	590	<b>1LL8 407-8AD□□</b>	3200	
630	745	450	743	8100	96.3	0.82	1160	670	<b>1LL8 453-8AD□□</b>	4000	
710	815	450	743	9130	96.4	0.83	1280	740	<b>1LL8 455-8AD□□</b>	4200	
800	920	450	743	10300	96.5	0.83	–	840	<b>1LL8 457-8AD□□</b>	4500	

A service factor (SF) of 1.05 is stamped onto all 1LL8 motors for mains-fed operation.

### Order No. supplements

Motor type	Penultimate position: Voltage code				Final position: Type of construction code			
	400 VΔ/690 VY	500 VΔ	690 VΔ	60 Hz 460 VΔ (see "Introduction" for outputs at 60 Hz)	Without flange IM B3	With flange IM V1 without protective cover	IM V1 with protective cover <sup>1)</sup>	IM B35
	6	5	0	9 L2F	0	8	4	6
<b>6-pole</b>								
<b>1LL8 315-...□□</b> to <b>1LL8 407-...□□</b>	□	○	– <sup>2)</sup>	○	□	✓	✓	✓
<b>1LL8 453-...□□</b> to <b>1LL8 457-...□□</b>	–	○	□	O. R.	□	✓	✓	✓
<b>8-pole</b>								
<b>1LL8 315-...□□</b> to <b>1LL8 455-...□□</b>	□	○	– <sup>2)</sup>	○	□	✓	✓	✓
<b>1LL8 457-...□□</b>	–	○	□	O. R.	□	✓	✓	✓

- Standard version
- Without additional charge
- ✓ With additional charge
- O. R. Possible on request
- Not possible

Order other voltages with voltage code **9** in the penultimate position and the corresponding order code (see "Special versions" in the "Selection and ordering data" under "Voltages").

Voltages or frequencies that are not covered by the predefined options can be ordered with order code **L1Y**. In this case, the output, voltage and frequency must be specified.

<sup>1)</sup> The "Second shaft extension" option, order code **K16** is not possible.

<sup>2)</sup> As special version with voltage code **9** and order code **L1Y** (specify output, voltage and frequency).

# IEC Squirrel-Cage Motors

## Non-standard motors frame size 315 and above

Self-ventilated motors with through ventilation  
for mains-fed operation – Cast-iron series 1LL8

### Selection and ordering data (continued)

Order No.	Locked-rotor torque	Locked-rotor current	Break-down torque	Torque class	Moment of inertia	Noise at rated output		Mech. limit speed	Parallel feeders required		
	At 50 Hz and for direct online starting as multiple of rated torque	At 50 Hz and for direct online starting as multiple of rated current	At 50 Hz and for direct online starting as multiple of rated torque	CL	$J$ kgm <sup>2</sup>	Measuring surface sound pressure level at 50 Hz	Sound power level at 50 Hz		$n_{max}$ rpm	400 V	500 V
	$T_{LR}/T_{rated}$	$I_{LR}/I_{rated}$	$T_B/T_{rated}$			$L_{pA}$ dB(A)	$L_{WA}$ dB(A)				
<b>6-pole, 1000 rpm at 50 Hz, 1200 rpm at 60 Hz, temperature class 155 (F), used acc. to temperature class 130 (B), IP23 degree of protection</b>											
1LL8 315-6AC□□	1.6	7	2.6	10	6	70	84	2950/2600 <sup>1)</sup>			
1LL8 317-6AC□□	1.7	7	2.6	10	7.3	70	84	2950/2600 <sup>1)</sup>	Yes		
1LL8 355-6AC□□	1.7	7	2.5	10	13	73	88	2500/2200 <sup>1)</sup>	Yes		
1LL8 357-6AC□□	1.8	7	2.6	10	16	73	88	2500/2200 <sup>1)</sup>	Yes	Yes	
1LL8 403-6AC□□	1.8	7	2.6	10	21	76	91	2200/1900 <sup>1)</sup>			
1LL8 405-6AC□□	1.8	7	2.6	10	24	76	91	2200/1900 <sup>1)</sup>	Yes		
1LL8 407-6AC□□	1.8	7	2.5	10	27	76	91	2200/1900 <sup>1)</sup>	Yes		
1LL8 453-6AD□□	1.5	7	2.5	7	35	78	93	2100/1800 <sup>1)</sup>	Yes	Yes	
1LL8 455-6AD□□	1.5	7	2.4	7	39	78	93	2100/1800 <sup>1)</sup>		Yes	
1LL8 457-6AD□□	1.5	7	2.5	7	44	78	93	2100/1800 <sup>1)</sup>		Yes	
<b>8-pole, 750 rpm at 50 Hz, 900 rpm at 60 Hz, temperature class 155 (F), used acc. to temperature class 130 (B), IP23 degree of protection</b>											
1LL8 315-8AC□□	1.6	5.8	2.4	10	6	67	81	2950/2600 <sup>1)</sup>			
1LL8 317-8AC□□	1.6	5.8	2.4	10	7.3	67	81	2950/2600 <sup>1)</sup>			
1LL8 355-8AC□□	1.6	6	2.4	10	13	69	84	2500/2200 <sup>1)</sup>			
1LL8 357-8AC□□	1.6	6	2.3	10	16	69	84	2500/2200 <sup>1)</sup>	Yes		
1LL8 403-8AD□□	1.3	5.8	2.3	7	21	72	87	2200/1900 <sup>1)</sup>			
1LL8 405-8AD□□	1.4	5.8	2.4	7	24	72	87	2200/1900 <sup>1)</sup>			
1LL8 407-8AD□□	1.4	6	2.4	7	27	72	87	2200/1900 <sup>1)</sup>	Yes		
1LL8 453-8AD□□	1.3	5.8	2.3	7	35	74	89	2100/1800 <sup>1)</sup>	Yes		
1LL8 455-8AD□□	1.3	5.8	2.3	7	39	74	89	2100/1800 <sup>1)</sup>	Yes	Yes	
1LL8 457-8AD□□	1.3	5.8	2.3	7	44	74	89	2100/1800 <sup>1)</sup>	Yes	Yes	

<sup>1)</sup> For vertical type of construction IM V1.

# IEC Squirrel-Cage Motors

## Non-standard motors frame size 315 and above

Self-ventilated motors with through-ventilation  
for converter-fed operation – Cast-iron series 1LL8

### Selection and ordering data

Rated output at		Frame size	Operating values at rated output and sinusoidal supply						Order No.	Price	Weight of IM B3 type of construction approx.
50 Hz	60 Hz		Rated speed at 50 Hz	Rated torque at 50 Hz	Efficiency at 50 Hz 4/4-load	Power factor at 50 Hz 4/4-load	Rated current at 50 Hz 400 V	Rated current at 50 Hz 690 V			
$P_{rated}$ kW	$P_{rated}$ kW	FS	$n_{rated}$ rpm	$T_{rated}$ Nm	$\eta_{rated}$ %	$\cos\phi_{rated}$	$I_{rated}$ A	$I_{rated}$ A	For Order No. supplements for voltage and type of construction, see table below	kg	
<b>2-pole, 3000 rpm at 50 Hz, 3600 rpm at 60 Hz, temperature class 155 (F), used acc. to temperature class 155 (F), IP23 degree of protection, specially for operation on SINAMICS or SIMOVERT MASTERDRIVES with standard insulation for voltages <math>\leq 500</math> V</b>											
315	345	315	2974	1010	96.1	0.92	510	300	1LL8 315-2PCQQ	1300	
400	440	315	2974	1280	96.4	0.92	650	375	1LL8 317-2PCQQ	1500	
450	–	355	2978	1440	96.4	0.91	740	430	1LL8 353-2PDQQ	1900	
500	–	355	2979	1600	96.6	0.92	810	470	1LL8 355-2PDQQ	2000	
630	–	355	2980	2020	96.9	0.93	1000	580	1LL8 357-2PDQQ	2200	
710	–	400	2984	2270	97.0	0.91	1160	670	1LL8 403-2PDQQ	2800	
800	–	400	2984	2560	97.1	0.92	1300	750	1LL8 405-2PDQQ	3000	
900	–	400	2985	2880	97.3	0.92	–	840	1LL8 407-2PDQQ	3200	
1000	–	450	2987	3200	97.3	0.93	–	920	1LL8 453-2PEQQ	4000	
1120	–	450	2986	3580	97.3	0.94	–	1020	1LL8 455-2PEQQ	4200	
1250	–	450	2986	4000	97.4	0.94	–	1140	1LL8 457-2PEQQ	4400	
<b>4-pole, 1500 rpm at 50 Hz, 1800 rpm at 60 Hz, temperature class 155 (F), used acc. to temperature class 155 (F), IP23 degree of protection, specially for operation on SINAMICS or SIMOVERT MASTERDRIVES with standard insulation for voltages <math>\leq 500</math> V</b>											
315	360	315	1483	2030	96.0	0.87	540	315	1LL8 315-4PCQQ	1300	
400	460	315	1484	2570	96.2	0.88	680	395	1LL8 317-4PCQQ	1500	
450	515	355	1487	2890	96.5	0.87	770	450	1LL8 353-4PCQQ	1900	
500	575	355	1487	3210	96.6	0.88	850	490	1LL8 355-4PCQQ	2000	
630	725	355	1488	4040	96.9	0.88	1060	620	1LL8 357-4PCQQ	2200	
710	815	400	1489	4550	96.9	0.88	1200	700	1LL8 403-4PCQQ	2800	
800	920	400	1490	5130	97.0	0.88	1360	780	1LL8 405-4PCQQ	3000	
900	1035	400	1491	5760	97.2	0.87	–	890	1LL8 407-4PCQQ	3200	
1000	1150	450	1492	6400	97.2	0.86	–	1000	1LL8 453-4PDQQ	4000	
1120	1280	450	1491	7170	97.2	0.89	–	1080	1LL8 455-4PDQQ	4200	
1250	1430	450	1490	8010	97.2	0.89	–	1200	1LL8 457-4PDQQ	4400	

### Order No. supplements

Motor type	Penultimate position: Voltage code				Final position: Type of construction code			
	400 V $\Delta$	400 V $\Delta$ /690 VY <sup>1)</sup>	500 V $\Delta$	690 V $\Delta$ <sup>1)</sup>	Without flange IM B3	With flange		
						IM V1 without protective cover	IM V1 with protective cover	IM B35
	<b>4</b>	<b>8</b>	<b>5</b>	<b>7</b>	<b>0</b>	<b>8</b>	<b>4</b>	<b>6</b>
1LL8 315-... QQ to 1LL8 405-... QQ	○	□	○	–	□	✓	✓	✓
1LL8 407-... QQ to 1LL8 457-... QQ	–	–	○	□	□	✓	✓	✓

- Standard version
- Without additional charge
- ✓ With additional charge
- Not possible

Order other voltages with voltage code **9** in the penultimate position and the corresponding order code (see "Special versions" in the "Selection and ordering data" under "Voltages").

Voltages or frequencies that are not covered by the predefined options can be ordered with order code **L1Y**. In this case, the output, voltage and frequency must be specified.

<sup>1)</sup> Motors with standard insulation can only be operated with converter circuit (du/dt or sinusoidal filter).

# IEC Squirrel-Cage Motors

## Non-standard motors frame size 315 and above

Self-ventilated motors with through-ventilation  
for converter-fed operation – Cast-iron series 1LL8

### Selection and ordering data (continued)

Order No.	Breakdown torque at 50 Hz as multiple of rated torque	Torque class	Moment of inertia	Measuring surface sound pressure level at 50 Hz	Sound power level at 50 Hz	Mech. limit speed		Parallel feeders required			
						$T_B/T_{rated}$	CL	$J$ kgm <sup>2</sup>	$L_{pA}$ dB(A)	$L_{WA}$ dB(A)	$n_{max}$ rpm
<b>2-pole, 3000 rpm at 50 Hz, 3600 rpm at 60 Hz, temperature class 155 (F), used acc. to temperature class 155 (F), IP23 degree of protection, specially for operation on SINAMICS or SIMOVERT MASTERDRIVES with standard insulation for voltages ≤500 V</b>											
<b>1LL8 315-2PC□□</b>	2.8	10	2.7	84 <sup>1)</sup>	99	3600	60			Yes	
<b>1LL8 317-2PC□□</b>	2.8	10	3.3	84 <sup>1)</sup>	99	3600	60			Yes	
<b>1LL8 353-2PD□□</b>	2.6	7	4.8	86 <sup>1)</sup>	101	3600/3100 <sup>2)</sup>	60/52 <sup>2)</sup>			Yes	Yes
<b>1LL8 355-2PD□□</b>	2.6	7	5.3	86 <sup>1)</sup>	101	3600/3100 <sup>2)</sup>	60/52 <sup>2)</sup>			Yes	Yes
<b>1LL8 357-2PD□□</b>	2.6	7	6.4	86 <sup>1)</sup>	101	3600/3100 <sup>2)</sup>	60/52 <sup>2)</sup>			Yes	
<b>1LL8 403-2PD□□</b>	2.6	7	8.6	88 <sup>1)</sup>	103	3600/3100 <sup>2)</sup>	60/52 <sup>2)</sup>			Yes	
<b>1LL8 405-2PD□□</b>	2.6	7	9.6	88 <sup>1)</sup>	103	3600/3100 <sup>2)</sup>	60/52 <sup>2)</sup>			Yes	Yes
<b>1LL8 407-2PD□□</b>	2.7	7	11	88 <sup>1)</sup>	103	3600/3100 <sup>2)</sup>	60/52 <sup>2)</sup>			Yes	
<b>1LL8 453-2PE□□</b>	2.9	5	19	90 <sup>1)</sup>	105	3000	50			Yes	
<b>1LL8 455-2PE□□</b>	2.7	5	21	90 <sup>1)</sup>	105	3000	50			Yes	Yes
<b>1LL8 457-2PE□□</b>	2.6	5	23	90 <sup>1)</sup>	105	3000	50			Yes	Yes
<b>4-pole, 1500 rpm at 50 Hz, 1800 rpm at 60 Hz, temperature class 155 (F), used acc. to temperature class 155 (F), IP23 degree of protection, specially for operation on SINAMICS or SIMOVERT MASTERDRIVES with standard insulation for voltages ≤500 V</b>											
<b>1LL8 315-4PC□□</b>	2.7	10	3.6	75	90	3000/2600 <sup>2)</sup>	100/87 <sup>2)</sup>			Yes	
<b>1LL8 317-4PC□□</b>	2.7	10	4.4	75	90	3000/2600 <sup>2)</sup>	100/87 <sup>2)</sup>			Yes	
<b>1LL8 353-4PC□□</b>	2.6	10	6.1	77	92	2500/2200 <sup>2)</sup>	83/73 <sup>2)</sup>			Yes	Yes
<b>1LL8 355-4PC□□</b>	2.6	10	6.8	77	92	2500/2200 <sup>2)</sup>	83/73 <sup>2)</sup>			Yes	Yes
<b>1LL8 357-4PC□□</b>	2.7	10	8.5	77	92	2500/2200 <sup>2)</sup>	83/73 <sup>2)</sup>			Yes	
<b>1LL8 403-4PC□□</b>	2.4	10	13	81	96	2200/1900 <sup>2)</sup>	73/63 <sup>2)</sup>			Yes	
<b>1LL8 405-4PC□□</b>	2.5	10	14	81	96	2200/1900 <sup>2)</sup>	73/63 <sup>2)</sup>			Yes	Yes
<b>1LL8 407-4PC□□</b>	2.6	10	16	81	96	2200/1900 <sup>2)</sup>	73/63 <sup>2)</sup>			Yes	
<b>1LL8 453-4PD□□</b>	2.8	7	23	84	99	2100/1800 <sup>2)</sup>	70/60 <sup>2)</sup>			Yes	
<b>1LL8 455-4PD□□</b>	2.6	7	26	84	99	2100/1800 <sup>2)</sup>	70/60 <sup>2)</sup>			Yes	Yes
<b>1LL8 457-4PD□□</b>	2.5	7	28	84	99	2100/1800 <sup>2)</sup>	70/60 <sup>2)</sup>			Yes	Yes

<sup>1)</sup> The noise values for **1LL8**, 2-pole are for guidance only.

<sup>2)</sup> For vertical type of construction IM V1.

# IEC Squirrel-Cage Motors

## Non-standard motors frame size 315 and above

Self-ventilated motors with through-ventilation  
for converter-fed operation – Cast-iron series 1LL8

### Selection and ordering data (continued)

Rated output at		Frame size	Operating values at rated output and sinusoidal supply						Order No.	Price	Weight of IM B3 type of construction approx.
50 Hz	60 Hz		Rated speed at 50 Hz	Rated torque at 50 Hz	Efficiency at 50 Hz 4/4-load	Power factor at 50 Hz 4/4-load	Rated current at 50 Hz 400 V	Rated current at 50 Hz 690 V			
$P_{rated}$ kW	$P_{rated}$ kW	FS	$n_{rated}$ rpm	$T_{rated}$ Nm	$\eta_{rated}$ %	$\cos\phi_{rated}$	$I_{rated}$ A	$I_{rated}$ A	For Order No. supplements for voltage and type of construction, see table below	kg	
<b>6-pole, 1000 rpm at 50 Hz, 1200 rpm at 60 Hz, temperature class 155 (F), used acc. to temperature class 155 (F), IP23 degree of protection, specially for operation on SINAMICS or SIMOVERT MASTERDRIVES with standard insulation for voltages ≤500 V</b>											
250	285	315	988	2420	95.4	0.88	430	250	1LL8 315-6PCQQ	1300	
315	360	315	988	3040	95.7	0.89	530	310	1LL8 317-6PCQQ	1500	
400	460	355	991	3850	96.1	0.88	680	395	1LL8 355-6PCQQ	2000	
500	575	355	991	4820	96.4	0.88	850	495	1LL8 357-6PCQQ	2200	
560	645	400	993	5390	96.6	0.87	960	560	1LL8 403-6PCQQ	2800	
630	725	400	993	6060	96.7	0.88	1060	620	1LL8 405-6PCQQ	3000	
710	815	400	993	6830	96.7	0.88	1200	700	1LL8 407-6PCQQ	3200	
800	920	450	993	7700	96.8	0.87	1380	790	1LL8 453-6PDQQ	4000	
900	1035	450	992	8660	96.8	0.88	–	880	1LL8 455-6PDQQ	4200	
1000	1150	450	993	9620	96.9	0.88	–	980	1LL8 457-6PDQQ	4500	
<b>8-pole, 750 rpm at 50 Hz, 900 rpm at 60 Hz, temperature class 155 (F), used acc. to temperature class 155 (F), IP23 degree of protection, specially for operation on SINAMICS or SIMOVERT MASTERDRIVES with standard insulation for voltages ≤500 V</b>											
200	230	315	738	2590	94.7	0.82	370	215	1LL8 315-8PCQQ	1300	
250	285	315	738	3240	95.0	0.82	465	270	1LL8 317-8PCQQ	1500	
315	360	355	740	4070	95.5	0.83	570	335	1LL8 355-8PCQQ	2000	
400	460	355	740	5160	95.6	0.84	720	415	1LL8 357-8PCQQ	2200	
450	515	400	741	5800	95.9	0.84	810	465	1LL8 403-8PDQQ	2800	
500	575	400	741	6440	96.1	0.84	890	520	1LL8 405-8PDQQ	3000	
560	645	400	742	7210	96.2	0.83	1020	590	1LL8 407-8PDQQ	3200	
630	745	450	743	8100	96.3	0.82	1160	670	1LL8 453-8PDQQ	4000	
710	815	450	743	9130	96.4	0.83	1280	740	1LL8 455-8PDQQ	4200	
800	920	450	743	10300	96.5	0.83	–	840	1LL8 457-8PDQQ	4500	

### Order No. supplements

Motor type	Penultimate position: Voltage code				Final position: Type of construction code			
	400 VΔ	400 VΔ/690 VY <sup>1)</sup>	500 VΔ	690 VΔ <sup>1)</sup>	Without flange IM B3	With flange IM V1 without protective cover	IM V1 with protective cover <sup>2)</sup>	IM B35
	4	8	5	7	0	8	4	6
<b>6-pole</b>								
1LL8 315-...QQ to 1LL8 453-...QQ	○	□	○	–	□	✓	✓	✓
1LL8 455-...QQ to 1LL8 457-...QQ	–	–	○	□	□	✓	✓	✓
<b>8-pole</b>								
1LL8 315-...QQ to 1LL8 455-...QQ	○	□	○	– <sup>3)</sup>	□	✓	✓	✓
1LL8 457-...QQ	–	–	○	□	□	✓	✓	✓

- Standard version
- Without additional charge
- ✓ With additional charge
- Not possible

Order other voltages with voltage code **9** in the penultimate position and the corresponding order code (see "Special versions" in the "Selection and ordering data" under "Voltages").

Voltages or frequencies that are not covered by the predefined options can be ordered with order code **L1Y**. In this case, the output, voltage and frequency must be specified.

<sup>1)</sup> Motors with standard insulation can only be operated with converter circuit (du/dt or sinusoidal filter).

<sup>2)</sup> The "Second shaft extension" option, order code **K16** is not possible.

<sup>3)</sup> As special version with voltage code **"9"** and order code **L1Y** (specify output, voltage and frequency).

# IEC Squirrel-Cage Motors

## Non-standard motors frame size 315 and above

Self-ventilated motors with through-ventilation  
for converter-fed operation – Cast-iron series 1LL8

### Selection and ordering data (continued)

Order No.	Breakdown torque at 50 Hz as multiple of rated torque	Torque class	Moment of inertia	Measuring surface sound pressure level at 50 Hz	Sound power level at 50 Hz	Mech. limit speed		Parallel feeders required		
						$T_B/T_{rated}$	CL	$J$ kgm <sup>2</sup>	$L_{p(A)}$ dB(A)	$L_{WA}$ dB(A)
<b>6-pole, 1000 rpm at 50 Hz, 1200 rpm at 60 Hz, temperature class 155 (F), used acc. to temperature class 155 (F), IP23 degree of protection, specially for operation on SINAMICS or SIMOVERT MASTERDRIVES with standard insulation for voltages ≤500 V</b>										
1LL8 315-6PC□□	2.6	10	6.0	70	84	2950/2600 <sup>1)</sup>	147/130 <sup>1)</sup>			
1LL8 317-6PC□□	2.6	10	7.3	70	84	2950/2600 <sup>1)</sup>	147/130 <sup>1)</sup>	Yes		
1LL8 355-6PC□□	2.5	10	13	73	88	2500/2200 <sup>1)</sup>	125/110 <sup>1)</sup>	Yes		
1LL8 357-6PC□□	2.6	10	16	73	88	2500/2200 <sup>1)</sup>	125/110 <sup>1)</sup>	Yes	Yes	
1LL8 403-6PC□□	2.6	10	21	76	91	2200/1900 <sup>1)</sup>	110/95 <sup>1)</sup>			
1LL8 405-6PC□□	2.6	10	24	76	91	2200/1900 <sup>1)</sup>	110/95 <sup>1)</sup>	Yes		
1LL8 407-6PC□□	2.5	10	27	76	91	2200/1900 <sup>1)</sup>	110/95 <sup>1)</sup>	Yes		
1LL8 453-6PD□□	2.5	7	35	78	93	2100/1800 <sup>1)</sup>	105/90 <sup>1)</sup>	Yes	Yes	
1LL8 455-6PD□□	2.4	7	39	78	93	2100/1800 <sup>1)</sup>	105/90 <sup>1)</sup>		Yes	
1LL8 457-6PD□□	2.5	7	44	78	93	2100/1800 <sup>1)</sup>	105/90 <sup>1)</sup>		Yes	
<b>8-pole, 750 rpm at 50 Hz, 900 rpm at 60 Hz, temperature class 155 (F), used acc. to temperature class 155 (F), IP23 degree of protection, specially for operation on SINAMICS or SIMOVERT MASTERDRIVES with standard insulation for voltages ≤500 V</b>										
1LL8 315-8PC□□	2.4	10	6.0	67	81	2950/2600 <sup>1)</sup>	196/173 <sup>1)</sup>			
1LL8 317-8PC□□	2.4	10	7.3	67	81	2950/2600 <sup>1)</sup>	196/173 <sup>1)</sup>			
1LL8 355-8PC□□	2.4	10	13	69	84	2500/2200 <sup>1)</sup>	166/146 <sup>1)</sup>			
1LL8 357-8PC□□	2.3	10	16	69	84	2500/2200 <sup>1)</sup>	166/146 <sup>1)</sup>	Yes		
1LL8 403-8PD□□	2.3	7	21	72	87	2200/1900 <sup>1)</sup>	146/126 <sup>1)</sup>			
1LL8 405-8PD□□	2.4	7	24	72	87	2200/1900 <sup>1)</sup>	146/126 <sup>1)</sup>			
1LL8 407-8PD□□	2.4	7	27	72	87	2200/1900 <sup>1)</sup>	146/126 <sup>1)</sup>	Yes		
1LL8 453-8PD□□	2.3	7	35	74	89	2100/1800 <sup>1)</sup>	140/120 <sup>1)</sup>	Yes		
1LL8 455-8PD□□	2.3	7	39	74	89	2100/1800 <sup>1)</sup>	140/120 <sup>1)</sup>	Yes	Yes	
1LL8 457-8PD□□	2.3	7	44	74	89	2100/1800 <sup>1)</sup>	140/120 <sup>1)</sup>	Yes	Yes	

<sup>1)</sup> For vertical type of construction IM V1.

# IEC Squirrel-Cage Motors

## Non-standard motors frame size 315 and above

Self-ventilated motors with through-ventilation  
for converter-fed operation – Cast-iron series 1LL8

### Selection and ordering data (continued)

Rated output at		Frame size	Operating values at rated output and sinusoidal supply						Order No.	Price	Weight of IM B3 type of construction approx.
50 Hz	60 Hz		Rated speed at 50 Hz	Rated torque at 50 Hz	Efficiency at 50 Hz 4/4-load	Efficiency at 50 Hz 3/4-load	Power factor at 50 Hz 4/4-load	Rated current at 50 Hz 690 V			
$P_{rated}$ kW	$P_{rated}$ kW	FS	$n_{rated}$ rpm	$T_{rated}$ Nm	$\eta_{rated}$ %	$\eta_{rated}$ %	$\cos\phi_{rated}$	$I_{rated}$ A		$m$ kg	
<b>2-pole, 3000 rpm at 50 Hz, 3600 rpm at 60 Hz, temperature class 155 (F), used acc. to temperature class 155 (F), IP23 degree of protection, specially for operation on SINAMICS or SIMOVERT MASTERDRIVES with special insulation for voltages &gt;500 V to 690 V</b>											
300	330	315	2977	962	95.9		0.91	290	1LL8315-2PM8□	1300	
380	415	315	2977	1219	96.3		0.91	365	1LL8317-2PM8□	1500	
435	475	355	2982	1393	96.2		0.90	420	1LL8353-2PM8□	1900	
485	530	355	2982	1553	96.5		0.90	465	1LL8355-2PM8□	2000	
610	670	355	2983	1953	96.8		0.91	580	1LL8357-2PM8□	2200	
690	755	400	2986	2207	96.9		0.91	650	1LL8403-2PM8□	2800	
770	845	400	2986	2463	96.9		0.91	730	1LL8405-2PM8□	3000	
860	945	400	2988	2749	97.2		0.92	800	1LL8407-2PM7□	3200	
965	1060	450	2988	3084	97.2		0.92	2x450	1LL8453-2PM7□	4000	
1085	1190	450	2987	3469	97.2		0.93	2x500	1LL8455-2PM7□	4200	
1210	1330	450	2985	3871	97.3		0.93	2x560	1LL8457-2PM7□	4400	
<b>4-pole, 1500 rpm at 50 Hz, 1800 rpm at 60 Hz, temperature class 155 (F), used acc. to temperature class 155 (F), IP23 degree of protection, specially for operation on SINAMICS or SIMOVERT MASTERDRIVES with special insulation for voltages &gt;500 V to 690 V</b>											
295	340	315	1485	1897	95.7		0.86	300	1LL8315-4PM8□	1300	
365	420	315	1487	2344	96.1		0.87	365	1LL8317-4PM8□	1500	
430	495	355	1489	2758	96.3		0.86	435	1LL8353-4PM8□	1900	
480	550	355	1489	3079	96.5		0.87	480	1LL8355-4PM8□	2000	
600	690	355	1490	3846	96.8		0.86	600	1LL8357-4PM8□	2200	
690	790	400	1491	4420	96.7		0.87	690	1LL8403-4PM8□	2800	
780	895	400	1491	4996	96.9		0.88	770	1LL8405-4PM8□	3000	
870	1000	400	1493	5565	97.1		0.85	880	1LL8407-4PM7□	3200	
980	1125	450	1493	6269	97.1		0.85	2x495	1LL8453-4PM7□	4000	
1095	1255	450	1492	7009	97.1		0.88	2x530	1LL8455-4PM7□	4200	
1225	1405	450	1491	7846	97.1		0.88	2x600	1LL8457-4PM7□	4400	

### Order No. supplements

Motor type	Final position: Type of construction code			
	Without flange		With flange	
	IM B3	IM V1 without protective cover	IM V1 with protective cover	IM B35
	<b>0</b>	<b>8</b>	<b>4</b>	<b>6</b>
1LL8 315-... □□	□	✓	✓	✓
to 1LL8 457-... □□				

- Standard version
- ✓ With additional charge

The voltage code is already in the Order No. as the penultimate position.

Assignment:

**7** = 690 VΔ

**8** = 400 VΔ/690 VY

Order other voltages with voltage code **9** in the penultimate position and the corresponding order code (see "Special versions" in the "Selection and ordering data" under "Voltages").

Voltages or frequencies that are not covered by the predefined options can be ordered with order code **L1Y**. In this case, the output, voltage and frequency must be specified.



# IEC Squirrel-Cage Motors

## Non-standard motors frame size 315 and above

Self-ventilated motors with through-ventilation  
for converter-fed operation – Cast-iron series 1LL8

### Selection and ordering data (continued)

Order No.	Breakdown torque at 50 Hz as multiple of rated torque	Parallel feeders required
	$T_B/T_{rated}$	690 V
<b>2-pole, 3000 rpm at 50 Hz, 3600 rpm at 60 Hz, temperature class 155 (F), used acc. to temperature class 155 (F), IP23 degree of protection, specially for operation on SINAMICS or SIMOVERT MASTERDRIVES with special insulation for voltages &gt;500 V to 690 V</b>		
1LL8315-2PM8□	2.9	
1LL8317-2PM8□	2.9	
1LL8353-2PM8□	2.7	
1LL8355-2PM8□	2.7	
1LL8357-2PM8□	2.7	
1LL8403-2PM8□	2.7	
1LL8405-2PM8□	2.7	
1LL8407-2PM7□	2.8	
1LL8453-2PM7□	3.0	Yes
1LL8455-2PM7□	2.8	Yes
1LL8457-2PM7□	2.7	Yes
<b>4-pole, 1500 rpm at 50 Hz, 1800 rpm at 60 Hz, temperature class 155 (F), used acc. to temperature class 155 (F), IP23 degree of protection, specially for operation on SINAMICS or SIMOVERT MASTERDRIVES with special insulation for voltages &gt;500 V to 690 V</b>		
1LL8315-4PM8□	2.9	
1LL8317-4PM8□	3.0	
1LL8353-4PM8□	2.7	
1LL8355-4PM8□	2.7	
1LL8357-4PM8□	2.8	
1LL8403-4PM8□	2.5	
1LL8405-4PM8□	2.6	
1LL8407-4PM7□	2.7	
1LL8453-4PM7□	2.9	Yes
1LL8455-4PM7□	2.7	Yes
1LL8457-4PM7□	2.6	Yes

# IEC Squirrel-Cage Motors

## Non-standard motors frame size 315 and above

Self-ventilated motors with through-ventilation  
for converter-fed operation – Cast-iron series 1LL8

### Selection and ordering data (continued)

Rated output at		Frame size	Operating values at rated output and sinusoidal supply						Order No. For Order No. supplements for voltage and type of construction, see table below	Price	Weight of IM B3 type of construction approx.  m kg
50 Hz	60 Hz		Rated speed at 50 Hz	Rated torque at 50 Hz	Efficiency at 50 Hz 4/4-load	Efficiency at 50 Hz 3/4-load	Power factor at 50 Hz 4/4-load	Rated current at 50 Hz 690 V			
$P_{rated}$ kW	$P_{rated}$ kW	FS	$n_{rated}$ rpm	$T_{rated}$ Nm	$\eta_{rated}$ %	$\eta_{rated}$ %	$\cos\phi_{rated}$	$I_{rated}$ A			
<b>6-pole, 1000 rpm at 50 Hz, 1200 rpm at 60 Hz, temperature class 155 (F), used acc. to temperature class 155 (F), IP23 degree of protection, specially for operation on SINAMICS or SIMOVERT MASTERDRIVES with special insulation for voltages &gt;500 V to 690 V</b>											
235	270	315	990	2267	95.0		0.87	240	1LL8315-6PM8□	1300	
295	335	315	990	2846	95.3		0.87	295	1LL8317-6PM8□	1500	
380	435	355	992	3658	95.6		0.87	380	1LL8355-6PM8□	2000	
475	545	355	993	4568	96.3		0.87	475	1LL8357-6PM8□	2200	
540	620	400	993	5193	96.4		0.86	550	1LL8403-6PM8□	2800	
610	700	400	994	5861	96.5		0.87	610	1LL8405-6PM8□	3000	
690	790	400	993	6636	96.6		0.87	690	1LL8407-6PM8□	3200	
780	895	450	993	7502	96.7		0.87	780	1LL8453-6PM8□	4000	
870	1000	450	993	8367	96.8		0.88	850	1LL8455-6PM7□	4200	
975	1120	450	993	9377	96.8		0.88	2x480	1LL8457-6PM7□	4500	
<b>8-pole, 750 rpm at 50 Hz, 900 rpm at 60 Hz, temperature class 155 (F), used acc. to temperature class 155 (F), IP23 degree of protection, specially for operation on SINAMICS or SIMOVERT MASTERDRIVES with special insulation for voltages &gt;500 V to 690 V</b>											
180	205	315	738	2329	94.1		0.81	198	1LL8315-8PM8□	1300	
225	255	315	740	2904	94.8		0.80	250	1LL8317-8PM8□	1500	
285	325	355	741	3673	95.1		0.81	310	1LL8355-8PM8□	2000	
365	415	355	741	4704	95.4		0.83	385	1LL8357-8PM8□	2200	
420	480	400	741	5413	95.5		0.83	445	1LL8403-8PM8□	2800	
465	530	400	742	5985	96.0		0.83	490	1LL8405-8PM8□	3000	
525	600	400	742	6757	96.0		0.82	560	1LL8407-8PM8□	3200	
610	700	450	742	7851	95.9		0.82	650	1LL8453-8PM8□	4000	
690	790	450	742	8881	96.0		0.82	730	1LL8455-8PM8□	4200	
760	870	450	742	9782	96.0		0.83	800	1LL8457-8PM8□	4500	

### Order No. supplements

Motor type	Final position: Type of construction code			
	Without flange IM B3	With flange IM V1 without protective cover	IM V1 with protective cover	IM B35
	<b>0</b>	<b>8</b>	<b>4</b>	<b>6</b>
1LL8 315-... □□ to 1LL8 457-... □□	□	✓	✓	✓

- Standard version
- ✓ With additional charge

The voltage code is already in the Order No. as the penultimate position.

Assignment:

**7** = 690 VΔ

**8** = 400 VΔ/690 VY

Order other voltages with voltage code **9** in the penultimate position and the corresponding order code (see "Special versions" in the "Selection and ordering data" under "Voltages").

Voltages or frequencies that are not covered by the predefined options can be ordered with order code **L1Y**. In this case, the output, voltage and frequency must be specified.

# IEC Squirrel-Cage Motors

## Non-standard motors frame size 315 and above

Self-ventilated motors with through-ventilation  
for converter-fed operation – Cast-iron series 1LL8

### Selection and ordering data (continued)

Order No.	Breakdown torque at 50 Hz as multiple of rated torque	Parallel feeders required
	$T_B/T_{rated}$	690 V
<b>6-pole, 1000 rpm at 50 Hz, 1200 rpm at 60 Hz, temperature class 155 (F), used acc. to temperature class 155 (F), IP23 degree of protection, specially for operation on SINAMICS or SIMOVERT MASTERDRIVES with special insulation for voltages &gt;500 V to 690 V</b>		
<b>1LL8315-6PM8□</b>	2.8	
<b>1LL8317-6PM8□</b>	2.8	
<b>1LL8355-6PM8□</b>	2.6	
<b>1LL8357-6PM8□</b>	2.7	
<b>1LL8403-6PM8□</b>	2.7	
<b>1LL8405-6PM8□</b>	2.7	
<b>1LL8407-6PM8□</b>	2.6	
<b>1LL8453-6PM8□</b>	2.6	
<b>1LL8455-6PM7□</b>	2.5	
<b>1LL8457-6PM7□</b>	2.6	Yes
<b>8-pole, 750 rpm at 50 Hz, 900 rpm at 60 Hz, temperature class 155 (F), used acc. to temperature class 155 (F), IP23 degree of protection, specially for operation on SINAMICS or SIMOVERT MASTERDRIVES with special insulation for voltages &gt;500 V to 690 V</b>		
<b>1LL8315-8PM8□</b>	2.7	
<b>1LL8317-8PM8□</b>	2.7	
<b>1LL8355-8PM8□</b>	2.7	
<b>1LL8357-8PM8□</b>	2.5	
<b>1LL8403-8PM8□</b>	2.5	
<b>1LL8405-8PM8□</b>	2.6	
<b>1LL8407-8PM8□</b>	2.6	
<b>1LL8453-8PM8□</b>	2.4	
<b>1LL8455-8PM8□</b>	2.4	
<b>1LL8457-8PM8□</b>	2.4	

# IEC Squirrel-Cage Motors

## Non-standard motors frame size 315 and above

### Special versions

#### Overview

##### Motor protection

KTY 84 temperature sensor:

Order code **A23**:

1 x KTY 84-130 (+ 1 x KTY 84-130 as spare)

The sensor is a semi-conductor sensor that changes its resistance depending on temperature in accordance with a defined, approximately linear characteristic. The temperature sensor is embedded in the winding head of the motor in the same manner as a PTC thermistor.

##### PT100 resistance thermometers

Order code **A61**: 6 PT100 resistance thermometers

The thermometer changes its resistance depending on the temperature in accordance with a defined, almost linear characteristic. The temperature sensor is embedded in the winding head of the motor in the same manner as a PTC thermistor.

Evaluation of the KTY or PT100 sensor is performed, for example, in the converter.

For motors for mains-fed operation, the 3RS10 temperature monitoring device that forms part of the protective equipment must be ordered separately, for further details, see Catalog LV 1.

For all non-standard motors of series 1LA8, 1PQ8 and 1LL8, if order code **A23** or **A61** is used, the standard PTC thermistors will be omitted. A combination of **A12** and **A61** or **A12** and **A23** is possible on request for an additional charge.

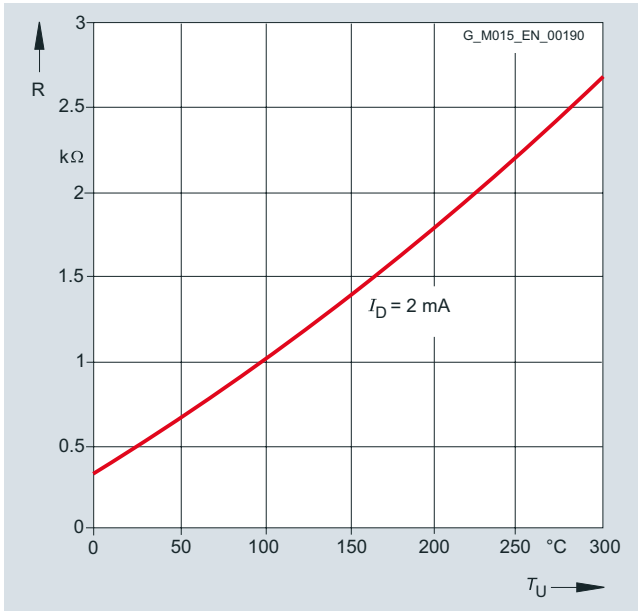

# IEC Squirrel-Cage Motors

## Non-standard motors frame size 315 and above

Special versions

### Selection and ordering data

#### Voltages

Additional order codes for other voltages or voltage codes  
(without **-Z** supplement)

For some non-standard voltages at 50 or 60 Hz, order codes are specified. They are ordered by specifying the code digit **9** for voltage in the 11th position of the Order No. and the appropriate order code.

Special versions	Voltage code 11th position of Order No.	Additional identification code with order code and plain text if required	Motor type frame size			
			315	355	400	450
<b>Self-ventilated motors for mains-fed operation – Cast-iron series 1LA8</b>						
<b>Self-ventilated motors for converter-fed operation – Cast-iron series 1LA8</b>						
			<b>1LA8</b>			
<b>Voltage at 60 Hz</b>						
380 VΔ/660 VY; 50 Hz output <sup>1)</sup>	<b>9</b>	<b>L2C</b>	✓	✓	✓	✓
380 VΔ/660 VY; 60 Hz output <sup>1)</sup>	<b>9</b>	<b>L2D</b>	✓	✓	✓	✓
440 VΔ; 50 Hz output <sup>1)</sup>	<b>9</b>	<b>L2R</b>	✓	✓	✓	✓
440 VΔ; 60 Hz output <sup>1)</sup>	<b>9</b>	<b>L2X</b>	✓	✓	✓	✓
460 VΔ; 50 Hz output <sup>1)</sup>	<b>9</b>	<b>L2T</b>	✓	✓	✓	✓
460 VΔ; 60 Hz output <sup>1)</sup>	<b>9</b>	<b>L2F</b>	✓	✓	✓	✓
575 VΔ; 50 Hz output	<b>9</b>	<b>L2V</b>	✓	✓	✓	✓
575 VΔ; 60 Hz output	<b>9</b>	<b>L2M</b>	✓	✓	✓	✓
<b>Non-standard voltage and/or frequencies</b>						
Standard winding (winding according to voltage code 0, 4, 5, 6, 7 or 8; rating plate will be stamped in accordance with order) <sup>2)</sup>	<b>9</b>	<b>L8Y •</b>	✓	✓	✓	✓
Non-standard winding for voltages between 380 and 690 V (voltages outside this range are available on request) <sup>2)</sup>	<b>9</b>	<b>L1Y •</b>	✓	✓	✓	✓

- ✓ With additional charge
- This order code only determines the price of the version – Additional plain text is required.

<sup>1)</sup> Only possible with rated outputs of up to 630 kW.

<sup>2)</sup> Plain text must be specified in the order: Voltage, frequency, circuit, required rated output in kW.

# IEC Squirrel-Cage Motors

## Non-standard motors frame size 315 and above

### Special versions

Special versions	Voltage code 11th position of Order No.	Additional identification code with order code and plain text if required	Motor type frame size			
			315	355	400	450
<b>Forced-air cooled motors with mounted separately driven fan for converter-fed operation – Cast-iron series 1PQ8</b>						
<b>1PQ8</b>						
<b>Voltage at 60 Hz</b>						
380 VΔ/660 VY; 50 Hz output <sup>1)</sup>	9	L2C	✓	✓	✓	✓
380 VΔ/660 VY; 60 Hz output <sup>1)</sup>	9	L2D	✓	✓	✓	✓
440 VΔ; 50 Hz output <sup>1)</sup>	9	L2R	✓	✓	✓	✓
440 VΔ; 60 Hz output <sup>1)</sup>	9	L2X	✓	✓	✓	✓
460 VΔ; 50 Hz output <sup>1)</sup>	9	L2T	✓	✓	✓	✓
460 VΔ; 60 Hz output <sup>1)</sup>	9	L2F	✓	✓	✓	✓
575 VΔ; 50 Hz output	9	L2V	✓	✓	✓	✓
575 VΔ; 60 Hz output	9	L2M	✓	✓	✓	✓
<b>Non-standard voltage and/or frequencies</b>						
Standard winding (winding according to voltage code 4, 5, 7 or 8; rating plate will be stamped in accordance with order) <sup>2)</sup>	9	L8Y •	✓	✓	✓	✓
Non-standard winding for voltages between 380 and 690 V (voltages outside this range are available on request) <sup>2)</sup>	9	L1Y •	✓	✓	✓	✓

- ✓ With additional charge
- This order code only determines the price of the version – Additional plain text is required.

#### Note:

The order codes listed above are only valid for motor series 1PQ8 with forced-air cooled motor.

The required voltage/frequency according to order code Y81 „Separately driven fan with non-standard voltage/frequency“ must be ordered in plain text with indication of the voltage, frequency and circuit.

<sup>1)</sup> Only possible with rated outputs of up to 630 kW.

<sup>2)</sup> Plain text must be specified in the order: Voltage, frequency, circuit, required rated output in kW.

# IEC Squirrel-Cage Motors

## Non-standard motors frame size 315 and above

### Special versions

Special versions	Voltage code 11th position of Order No.	Additional identification code with order code and plain text if required	Motor type frame size			
			315	355	400	450
<b>Self-ventilated motors with through ventilation for mains-fed and converter-fed operation – Cast-iron series 1LL8</b>						
<b>1LL8</b>						
<b>Voltage at 60 Hz</b>						
380 VΔ/660 VY; 50 Hz output <sup>1)</sup>	9	L2C	✓	✓ <sup>3)</sup>	✓ <sup>3)</sup>	✓ <sup>3)</sup>
380 VΔ/660 VY; 60 Hz output <sup>1)</sup>	9	L2D	✓	✓	✓	✓
440 VΔ; 50 Hz output <sup>1)</sup>	9	L2R	✓	✓	✓	✓
440 VΔ; 60 Hz output <sup>1)</sup>	9	L2X	✓	✓	✓	✓
460 VΔ; 50 Hz output <sup>1)</sup>	9	L2T	✓	✓	✓	✓
460 VΔ; 60 Hz output <sup>1)</sup>	9	L2F	✓	✓	✓	✓
575 VΔ; 50 Hz output	9	L2V	✓	✓	✓	✓
575 VΔ; 60 Hz output	9	L2M	✓	✓	✓	✓
<b>Non-standard voltage and/or frequencies</b>						
Standard winding (winding according to voltage code 0, 5 or 6; rating plate will be stamped in accordance with order) <sup>2)</sup>	9	L8Y •	✓	✓	✓	✓
Non-standard winding for voltages between 380 and 690 V (voltages outside this range are available on request) <sup>2)</sup>	9	L1Y •	✓	✓	✓	✓

- ✓ With additional charge
- This order code only determines the price of the version – Additional plain text is required.

<sup>1)</sup> Only possible with rated outputs of up to 630 kW.

<sup>2)</sup> Plain text must be specified in the order: Voltage, frequency, circuit, required rated output in kW.

<sup>3)</sup> Not possible for 2-pole motors in 60 Hz version of frame size 355 and above.

# IEC Squirrel-Cage Motors

## Non-standard motors frame size 315 and above

### Special versions

#### Options

Options or order codes (supplement **-Z** is required)

Special versions	Additional identification code <b>-Z</b> with order code and plain text if required	Motor type frame size							
		315	355	400	450	315	355	400	450
<b>Self-ventilated motors for mains-fed and converter-fed operation 1LA8</b>									
		<b>1LA8</b> Mains-fed operation				<b>1LA8</b> Converter-fed operation			
<b>Standardline</b>									
Standardline version <sup>1)</sup>	<b>B20</b>	○	○	–	–	○	○	–	–
<b>Motor protection</b>									
Motor protection with PTC thermistors with 6 embedded temperature sensors for alarm and tripping <sup>2)</sup>	<b>A12</b>	□	□	□	□	□	□	□	□
Motor temperature detection with embedded temperature sensor KTY 84-130 <sup>3)</sup>	<b>A23</b>	○	○	○	○	○	○	○	○
Installation of 6 PT 100 resistance thermometers in stator winding <sup>5)</sup>	<b>A61</b>	✓	✓	✓	✓	✓	✓	✓	✓
Installation of 2 PT 100 screw-in resistance thermometers (basic circuit) for rolling-contact bearings	<b>A72</b>	✓	✓	✓	✓	✓	✓	✓	✓
<b>Motor connection and connection box</b>									
Two-part plate on connection box	<b>K06</b>	✓ <sup>4)</sup>	✓	✓	✓	O. R.	O. R.	O. R.	O. R.
Undrilled entry plate	<b>L01</b>	○ <sup>4)</sup>	○	○	○	○ <sup>4)</sup>	○	○	○
Connection box on RHS	<b>K09</b>	□	□	□	□	□	□	□	□
Connection box on LHS	<b>K10</b>	○	○	○	○	○	○	○	○
Connection box above (1XB1 634 connection box) <sup>5)</sup>	<b>K11</b>	✓	✓	✓	✓	✓	✓	✓	✓
Cable gland DIN 89280, maximum configuration	<b>K57</b>	✓	✓	✓	✓	✓	✓	✓	✓
Rotation of the connection box through 90°, entry from DE	<b>K83</b>	○	○	○	○	○	○	○	○
Rotation of the connection box through 90°, entry from NDE	<b>K84</b>	○	○	○	○	○	○	○	○
Rotation of connection box through 180°	<b>K85</b>	○	○	○	○	○	○	○	○
Larger connection box (1XB1 621 connection box)	<b>M58</b>	✓	□ <sup>6)</sup>	–	–	✓	□ <sup>6)</sup>	–	–
Larger connection box (1XB1 631 connection box)	<b>L00</b>	✓	✓ <sup>6)</sup>	□	□	✓	✓ <sup>6)</sup>	□	□
6 cables protruding, 1.5 m long	<b>L48</b>	O. R.	O. R.	O. R.	O. R.	O. R.	O. R.	O. R.	O. R.
6 cables protruding, 3 m long	<b>L49</b>	O. R.	O. R.	O. R.	O. R.	O. R.	O. R.	O. R.	O. R.
Auxiliary connection box 1XB9 016 (cast-iron)	<b>M50</b>	✓	✓	✓	✓	✓	✓	✓	✓
Auxiliary connection box 1XB3 020 <sup>7)</sup>	<b>L97</b>	✓	✓	✓	✓	✓	✓	✓	✓
Auxiliary connection box 1XB9 014 (aluminum)	<b>M88</b>	✓	✓	✓	✓	✓	✓	✓	✓
Connection box on NDE	<b>M64</b>	✓	✓	✓	✓	✓	✓	✓	✓
<b>Windings and insulation</b>									
Temperature class 155 (F), used acc. to 155 (F), with service factor (SF 1.1, SF 1.05 from frame size 400) <sup>8)</sup>	<b>C11</b>	✓	✓	✓	✓	–	–	–	–
Temperature class 155 (F), used acc. to 155 (F), with increased output (10 %, 5 % from frame size 400) <sup>8)</sup>	<b>C12</b>	✓	✓	✓	✓	–	–	–	–
Temperature class 155 (F), used acc. to 155 (F), with increased coolant temperature (55 °C, 50 °C from frame size 400) <sup>8)</sup>	<b>C13</b>	✓	✓	✓	✓	–	–	–	–
Temperature class 180 (H), used acc. to 155 (F), with service factor (SF 1.1) <sup>8)</sup>	<b>C14</b>	✓	✓	✓	✓	✓	✓	✓	✓

For legend and footnotes, see Page 3/53.



# IEC Squirrel-Cage Motors

## Non-standard motors frame size 315 and above

### Special versions

Special versions	Additional identification code <b>-Z</b> with order code and plain text if required	Motor type frame size							
		315	355	400	450	315	355	400	450
<b>Self-ventilated motors for mains-fed and converter-fed operation 1LA8</b>									
		<b>1LA8</b> Mains-fed operation				<b>1LA8</b> Converter-fed operation			
<b>Colors and paint finish</b>									
Standard finish in RAL 7030 stone gray		☐	☐	☐	☐	☐	☐	☐	☐
Standard paint finish in other colors	<b>Y53 •</b> and standard finish RAL .....	✓	✓	✓	✓	✓	✓	✓	✓
Special finish in RAL 7030 stone gray	<b>K26</b>	✓	✓	✓	✓	✓	✓	✓	✓
Special finish in other colors	<b>Y54 •</b> and special finish RAL .....	✓	✓	✓	✓	✓	✓	✓	✓
Unpainted (only cast iron parts primed)	<b>K23</b>	○	○	○	○	○	○	○	○
<b>Special technology</b>									
Mounting of brake (incl. brake of Stromag)	<b>H47</b>	O. R.	O. R.	O. R.	O. R.	O. R.	O. R.	O. R.	O. R.
Mounting of LL 861 900 220 rotary pulse encoder	<b>H70</b>	–	–	–	–	✓	✓	✓	✓
Mounting of HOG 10 D 1024 I rotary pulse encoder	<b>H73</b>	–	–	–	–	✓	✓	✓	✓
Prepared for mounting LL 861 900 220	<b>H78</b>	–	–	–	–	✓	✓	✓	✓
Prepared for mounting HOG 10 D 1024 I	<b>H80</b>	–	–	–	–	✓	✓	✓	✓
Mounting a special type of rotary pulse encoder	<b>Y70 •</b> and encoder designation	–	–	–	–	O. R.	O. R.	O. R.	O. R.
<b>Mechanical design and degrees of protection</b>									
Low-noise version for 2-pole motors with clockwise direction of rotation	<b>K37</b>	✓	☐	☐	☐	✓	☐	☐	☐
Low-noise version for 2-pole motors with counter-clockwise direction of rotation	<b>K38</b>	✓	○	○	○	✓	○	○	○
IP56 degree of protection (non-heavy-sea)	<b>K52</b>	✓	✓	✓	✓	✓	✓	✓	✓
Non-rusting screws (externally)	<b>M27</b>	✓	✓	✓	✓	✓	✓	✓	✓
<b>Coolant temperature and site altitude</b>									
Coolant temperature –40 to +40 °C	<b>D03</b>	✓	✓	✓	✓	✓	✓	✓	✓
Coolant temperature –30 to +40 °C	<b>D04</b>	✓	✓	✓	✓	✓	✓	✓	✓
Coolant temperature 45 °C, derating 4 % <sup>9)</sup>	<b>D11</b>	○	○	○	○	○	○	○	○
Coolant temperature 50 °C, derating 8 % <sup>9)</sup>	<b>D12</b>	○	○	○	○	○	○	○	○
Coolant temperature 55 °C, derating 13 % <sup>9)</sup>	<b>D13</b>	○	○	○	○	○	○	○	○
Coolant temperature 60 °C, derating 18 % <sup>9)</sup>	<b>D14</b>	○	○	○	○	○	○	○	○
<b>Designs in accordance with standards and specifications</b>									
Electrical according to NEMA MG1-12	<b>D30</b>	✓	✓	✓	✓	✓	✓	✓	✓
Design according to UL with "Recognition Mark"	<b>D31</b>	✓	✓	✓	✓	✓	✓	✓	✓
Canadian regulations (CSA)	<b>D40</b>	✓	✓	✓	✓	✓	✓	✓	✓

# IEC Squirrel-Cage Motors

## Non-standard motors frame size 315 and above

### Special versions

Special versions	Additional identification code <b>-Z</b> with order code and plain text if required	Motor type frame size								
		315	355	400	450	315	355	400	450	
<b>Self-ventilated motors for mains-fed and converter-fed operation 1LA8</b>										
			<b>1LA8</b> Mains-fed operation				<b>1LA8</b> Converter-fed operation			
<b>Design for Zones 1, 2 and 22 according to ATEX <sup>10)</sup></b>										
Design for Zone 2 for mains-fed operation Ex nA II T3 to IEC/EN 60079-15 <sup>11) 12) 13)</sup>	<b>M72</b>		✓	✓	✓	✓	–	–	–	–
Design for Zone 2 for converter-fed operation, reduced output Ex nA II T3 to IEC/EN 60079-15 <sup>11) 12) 13) 14)</sup>	<b>M73</b>		–	–	–	–	O. R.	O. R.	O. R.	O. R.
Design for Zone 22 for non-conducting dust (IP55) for mains-fed operation <sup>13)</sup>	<b>M35</b>		✓	✓	✓	✓	–	–	–	–
Design for Zone 22 for non-conducting dust (IP55) for converter-fed operation <sup>12) 13)</sup>	<b>M39</b>		–	–	–	–	✓	✓	✓	✓
VIK version <sup>13) 15)</sup>	<b>K30</b>		✓	✓	–	–	O. R.	O. R.	–	–
Stamping of Ex nA II on VIK rating plate	<b>C27</b>		✓	✓	–	–	O. R.	O. R.	–	–
<b>Bearings and lubrication</b>										
Measuring nipple for SPM shock pulse measurement for bearing inspection	<b>G50</b>		✓	✓	✓	✓	✓	✓	✓	✓
Bearing design for increased cantilever forces <sup>16)</sup>	<b>K20</b>		✓	✓	–	–	✓	✓	–	–
<b>Balance and vibration quantity</b>										
Vibration quantity level B	<b>K02</b>		✓	✓	✓	✓	✓	✓	✓	✓
Full key balancing	<b>L68</b>		✓	✓	✓	✓	✓	✓	✓	✓
<b>Shaft and rotor</b>										
Second standard shaft extension <sup>17)</sup>	<b>K16</b>		✓	✓	✓	✓	✓	✓	✓	✓
Shaft extension with standard dimensions, without featherkey way	<b>K42</b>		✓	✓	✓	✓	✓	✓	✓	✓
Non-standard cylindrical shaft extension	<b>Y55 •</b> and identification code		✓	✓	✓	✓	✓	✓	✓	✓
<b>Heating and ventilation</b>										
Metal external fan	<b>K35</b>		✓	✓	✓	✓	✓	✓	✓	✓
Anti-condensation heaters for 230 V	<b>K45</b>		✓	✓	✓	✓	✓	✓	✓	✓
Anti-condensation heaters for 115 V	<b>K46</b>		✓	✓	✓	✓	✓	✓	✓	✓
<b>Rating plate and extra rating plates</b>										
Second rating plate, loose	<b>K31</b>		✓	✓	✓	✓	✓	✓	✓	✓
Extra rating plate or rating plate with deviating rating plate data	<b>Y80 •</b> and identification code		✓	✓	✓	✓	✓	✓	✓	✓
Extra rating plate with identification code	<b>Y82 •</b> and identification code		✓	✓	✓	✓	✓	✓	✓	✓
<b>Packaging, safety notes, documentation and test certificates <sup>18)</sup></b>										
Document – Electrical data sheet	<b>B31</b>		✓	✓	✓	✓	✓	✓	✓	✓
Document – Order dimension drawing	<b>B32</b>		✓	✓	✓	✓	✓	✓	✓	✓
Document – Load characteristics	<b>B37</b>		O. R.	O. R.	O. R.	O. R.	O. R.	O. R.	O. R.	O. R.
Standard test (routine test) with acceptance	<b>F01</b>		✓	✓	✓	✓	✓	✓	✓	✓
Visual acceptance and report handover with acceptance	<b>F03</b>		✓	✓	✓	✓	✓	✓	✓	✓

For legend and footnotes, see Page 3/53.

# IEC Squirrel-Cage Motors

## Non-standard motors frame size 315 and above

### Special versions

Special versions	Additional identification code -Z with order code and plain text if required	Motor type frame size							
		315	355	400	450	315	355	400	450
<b>Self-ventilated motors for mains-fed and converter-fed operation 1LA8</b>									
		<b>1LA8</b> Mains-fed operation				<b>1LA8</b> Converter-fed operation			
<b>Packaging, safety notes, documentation and test certificates</b> <sup>18)</sup> (continued)									
Temperature-rise test, without acceptance	<b>F04</b>	✓	✓	✓	✓	✓	✓	✓	✓
Temperature-rise test, with acceptance	<b>F05</b>	✓	✓	✓	✓	✓	✓	✓	✓
Noise measurement in no-load operation, no noise analysis, no acceptance	<b>F28</b>	✓	✓	✓	✓	✓	✓	✓	✓
Noise measurement in no-load operation, no noise analysis, with acceptance	<b>F29</b>	✓	✓	✓	✓	✓	✓	✓	✓
Noise measurement in no-load operation, with noise analysis, without acceptance	<b>F62</b>	✓	✓	✓	✓	✓	✓	✓	✓
Noise measurement in no-load operation, with noise analysis, with acceptance	<b>F63</b>	✓	✓	✓	✓	✓	✓	✓	✓
Recording of current and torque curves with torque metering shaft during starting, without acceptance	<b>F34</b>	✓	✓	✓	✓	–	–	–	–
Recording of current and torque curves with torque metering shaft during starting, with acceptance	<b>F35</b>	✓	✓	✓	✓	–	–	–	–
Measurement of locked-rotor torque and current, without acceptance	<b>F52</b>	✓	✓	✓	✓	–	–	–	–
Measurement of locked-rotor torque and current, with acceptance	<b>F53</b>	✓	✓	✓	✓	–	–	–	–
Type test with heat run for horizontal motors, without acceptance	<b>F82</b>	✓	✓	✓	✓	✓	✓	✓	✓
Type test with heat run for horizontal motors, with acceptance	<b>F83</b>	✓	✓	✓	✓	✓	✓	✓	✓
Type test with heat run for vertical motors, without acceptance	<b>F92</b>	✓	✓	✓	✓	✓	✓	✓	✓
Type test with heat run for vertical motors, with acceptance	<b>F93</b>	✓	✓	✓	✓	✓	✓	✓	✓

- Standard version
- Without additional charge
- This order code only determines the price of the version – Additional plain text is required.
- R. Possible on request
- ✓ With additional charge
- Not possible

<sup>1)</sup> For 4-pole version only, type of construction IM B3, 400 V $\Delta$ /690 VY or 500 V $\Delta$  voltage (no special insulation). Only the following short codes can be ordered in combination with the *Standardline*: **A23, A61, A72, G50, H70, H73, K09, K10, K45, K46, K83, K84, K85, L00, L97, M58** (only frame size 315), **M88, Y53**.

<sup>2)</sup> Evaluation with appropriate tripping unit (see Catalog LV 1) is recommended.

<sup>3)</sup> The standard thermistors are omitted. If PTC thermistors are required as well as KTYs or PT100s, this must be specified in the order in plain text. A combination of **A12** and **A61** or **A12** and **A23** is possible on request for an additional charge.

<sup>4)</sup> Only possible in combination with the larger connection boxes 1XB1 621 or 1XB1 631 (order codes **M58** or **L00**).

<sup>5)</sup> A combination with the order codes **M88** and **M50** is not possible. Connection box 1XP1 634 can be rotated through 4 x 90°. Cable entry is from NDE or the delivery position. Dimension drawings available on request.

<sup>6)</sup> With 1LA8 357-2 and 1LA8 357-4, connection box 1XB1 631 is supplied in the standard version.

<sup>7)</sup> VIK version is not possible.

<sup>8)</sup> Use according to temperature class 180 (H) is not possible. All 400 V version are available on request. Due to the rated current, a larger connection box of type 1XB9 600, which is part of order code **C14**, is generally provided for frame sizes 400 (2- and 4-pole) and 450 (all no. of poles).

<sup>9)</sup> Site altitude up to 1000 m above sea level.

<sup>10)</sup> Explosion-protected encoders are available on request.

<sup>11)</sup> Only admissible for use in accordance with temperature class 130 (B). PTC thermistors for temperature class 130 (B) are included. For compliance with temperature class 130 (B), derating is necessary in the case of converter-fed operation in Zones 2 and 22. Derating data are available on request.

<sup>12)</sup> These motors do not have a rated voltage range stamped on the rating plate.

<sup>13)</sup> For options **K30, M35, M39, M72, M73** an additional metal external fan order code **K35** must be ordered.

<sup>14)</sup> In the order, the "Speed range and torque characteristic" must be specified in plain text. A system test is necessary for  $M = \text{constant}$ .

<sup>15)</sup> The VIK version comprises Zone 2 for mains-fed operation – without Ex nA II marking on rating plate. For 2-pole motors of frame size 315, the low-noise version is also required. Order code **K37** or **K38** and additionally the metal external fan order code **K35**. Note the specified output and dimensions. For 1LA8 353 to 1LA8 357 motors, the connection box cannot be rotated by 4 x 90°.

<sup>16)</sup> Not possible for 2-pole motors and motors of vertical type of construction.

<sup>17)</sup> Please inquire in the case of 2-pole motors and motors in vertical type of construction.

<sup>18)</sup> Type testing is also performed for converter-fed operation.

# IEC Squirrel-Cage Motors

## Non-standard motors frame size 315 and above

### Special versions

Options or order codes (supplement **-Z** is required)

Special versions	Additional identification code <b>-Z</b> with order code and plain text if required	Motor type frame size			
		315	355	400	450
<b>Forced-air cooled motors with mounted separately driven fan for converter-fed operation 1PQ8</b>					
<b>1PQ8</b>					
Converter-fed operation					
<b>Standardline</b>					
Standardline version	<b>B20</b>	–	–	–	–
<b>Motor protection</b>					
Motor protection with PTC thermistors with 6 embedded temperature sensors for alarm and tripping <sup>1)</sup>	<b>A12</b>	☐	☐	☐	☐
Motor temperature detection with embedded temperature sensor KTY 84-130 <sup>2)</sup>	<b>A23</b>	○	○	○	○
Installation of 6 PT 100 resistance thermometers in stator winding <sup>2)</sup>	<b>A61</b>	✓	✓	✓	✓
Installation of 2 PT 100 screw-in resistance thermometers (basic circuit) for rolling-contact bearings	<b>A72</b>	✓	✓	✓	✓
<b>Motor connection and connection box</b>					
Two-part plate on connection box	<b>K06</b>	O. R.	O. R.	O. R.	O. R.
Undrilled entry plate	<b>L01</b>	○ <sup>3)</sup>	○	○	○
Connection box on RHS	<b>K09</b>	☐	☐	☐	☐
Connection box on LHS	<b>K10</b>	○	○	○	○
Connection box above (1XB1 634 connection box) <sup>4)</sup>	<b>K11</b>	✓	✓	✓	✓
Cable gland, maximum configuration	<b>K57</b>	✓	✓	✓	✓
Rotation of the connection box through 90°, entry from DE	<b>K83</b>	○	○	○	○
Rotation of the connection box through 90°, entry from NDE	<b>K84</b>	○	○	○	○
Rotation of connection box through 180°	<b>K85</b>	○	○	○	○
Larger connection box (1XB1 621 connection box)	<b>M58</b>	✓	☐ <sup>5)</sup>	–	–
Larger connection box (1XB1 631 connection box)	<b>L00</b>	✓	✓ <sup>5)</sup>	☐	☐
6 cables protruding, 1.5 m long	<b>L48</b>	O. R.	O. R.	O. R.	O. R.
6 cables protruding, 3 m long	<b>L49</b>	O. R.	O. R.	O. R.	O. R.
Auxiliary connection box 1XB9 016 (cast-iron)	<b>M50</b>	✓	✓	✓	✓
Auxiliary connection box 1XB3 020	<b>L97</b>	✓	✓	✓	✓
Auxiliary connection box 1XB9 014 (aluminum)	<b>M88</b>	✓	✓	✓	✓
Connection box on NDE	<b>M64</b>	✓	✓	✓	✓

For legend and footnotes, see Page 3/57.

# IEC Squirrel-Cage Motors

## Non-standard motors frame size 315 and above

### Special versions

Special versions	Additional identification code -Z with order code and plain text if required	Motor type frame size			
		315	355	400	450
<b>Forced-air cooled motors with mounted separately driven fan for converter-fed operation 1PQ8</b>					
<b>1PQ8</b> Converter-fed operation					
<b>Windings and insulation</b>					
Temperature class 180 (H), used acc. to 155 (F), with service factor (SF 1.1) <sup>6)</sup>	<b>C14</b>	✓	✓	✓	✓
<b>Colors and paint finish</b>					
Standard finish in RAL 7030 stone gray		□	□	□	□
Standard paint finish in other colors	<b>Y53 •</b> and standard finish RAL ....	✓	✓	✓	✓
Special finish in RAL 7030 stone gray	<b>K26</b>	✓	✓	✓	✓
Special finish in other colors	<b>Y54 •</b> and special finish RAL ....	✓	✓	✓	✓
Unpainted (only cast-iron parts primed)	<b>K23</b>	○	○	○	○
<b>Special technology</b>					
Mounting of brake (incl. brake of Stromag)	<b>H47</b>	O. R.	O. R.	O. R.	O. R.
Mounting of LL 861 900 220 rotary pulse encoder	<b>H70</b>	✓	✓	✓	✓
Mounting of HOG 10 D 1024 I rotary pulse encoder	<b>H73</b>	✓	✓	✓	✓
Prepared for mounting LL 861 900 220	<b>H78</b>	✓	✓	✓	✓
Prepared for mounting HOG 10 D 1024 I	<b>H80</b>	✓	✓	✓	✓
Mounting a special type of rotary pulse encoder	<b>Y70 •</b> and encoder designation	O. R.	O. R.	O. R.	O. R.
<b>Mechanical design and degrees of protection</b>					
Low-noise version for 2-pole motors with clockwise direction of rotation	<b>K37</b>	–	–	–	–
Low-noise version for 2-pole motors with counter-clockwise direction of rotation	<b>K38</b>	–	–	–	–
IP56 degree of protection (non-heavy-sea)	<b>K52</b>	O. R.	O. R.	O. R.	O. R.
Non-rusting screws (externally) <sup>7)</sup>	<b>M27</b>	✓	✓	✓	✓
<b>Coolant temperature and site altitude</b>					
Coolant temperature –40 to +40 °C	<b>D03</b>	O. R.	O. R.	O. R.	O. R.
Coolant temperature –30 to +40 °C	<b>D04</b>	O. R.	O. R.	O. R.	O. R.
Coolant temperature 45 °C, derating 4 % <sup>8)</sup>	<b>D11</b>	○	○	○	○
Coolant temperature 50 °C, derating 8 % <sup>8)</sup>	<b>D12</b>	○	○	○	○
Coolant temperature 55 °C, derating 13 % <sup>8)</sup>	<b>D13</b>	○	○	○	○
Coolant temperature 60 °C, derating 18 % <sup>8)</sup>	<b>D14</b>	○	○	○	○

# IEC Squirrel-Cage Motors

## Non-standard motors frame size 315 and above

### Special versions

Special versions	Additional identification code -Z with order code and plain text if required	Motor type frame size			
		315	355	400	450
<b>Forced-air cooled motors with mounted separately driven fan for converter-fed operation 1PQ8</b>					
<b>1PQ8</b>					
Converter-fed operation					
<b>Designs in accordance with standards and specifications</b>					
Electrical according to NEMA MG1-12 <sup>9)</sup>	<b>D30</b>	✓	✓	✓	✓
Design according to UL with "Recognition Mark"	<b>D31</b>	✓	✓	✓	✓
Canadian regulations (CSA)	<b>D40</b>	✓	✓	✓	✓
<b>Design for Zones 2 and 22 according to ATEX<sup>10)</sup></b>					
Design for Zone 2 for mains-fed operation Ex nA II T3 to IEC/EN 60079-15	<b>M72</b>	–	–	–	–
Design for Zone 2 for converter-fed operation, reduced output Ex nA II T3 to IEC/EN 60079-15 <sup>11) 12) 13)</sup>	<b>M73</b>	O. R.	O. R.	O. R.	O. R.
Design for Zone 22 for non-conducting dust (IP55) for mains-fed operation	<b>M35</b>	–	–	–	–
Design for Zone 22 for non-conducting dust (IP55) for converter-fed operation	<b>M39</b>	–	–	–	–
VIK version	<b>K30</b>	–	–	–	–
Stamping of Ex nA II on VIK rating plate	<b>C27</b>	–	–	–	–
<b>Bearings and lubrication</b>					
Measuring nipple for SPM shock pulse measurement for bearing inspection	<b>G50</b>	✓	✓	✓	✓
Bearing design for increased cantilever forces <sup>14)</sup>	<b>K20</b>	✓	✓	–	–
<b>Balance and vibration quantity</b>					
Vibration quantity level B	<b>K02</b>	✓	✓	✓	✓
Full key balancing	<b>L68</b>	✓	✓	✓	✓
<b>Shaft and rotor</b>					
Second standard shaft extension	<b>K16</b>	–	–	–	–
Shaft extension with standard dimensions, without featherkey way	<b>K42</b>	✓	✓	✓	✓
Non-standard cylindrical shaft extension	<b>Y55 •</b> and identification code	✓	✓	✓	✓
<b>Heating and ventilation</b>					
Anti-condensation heaters for 230 V	<b>K45</b>	✓	✓	✓	✓
Anti-condensation heaters for 115 V	<b>K46</b>	✓	✓	✓	✓
Separately driven fan with non-standard voltage and/or frequency <sup>15)</sup>	<b>Y81 •</b> and identification code	✓	✓	✓	✓
<b>Rating plate and extra rating plates</b>					
Second rating plate, loose	<b>K31</b>	✓	✓	✓	✓
Extra rating plate or rating plate with deviating rating plate data	<b>Y80 •</b> and identification code	✓	✓	✓	✓
Extra rating plate with identification code	<b>Y82 •</b> and identification code	✓	✓	✓	✓
<b>Packaging, safety notes, documentation and test certificates<sup>16)</sup></b>					
Document – Electrical data sheet	<b>B31</b>	✓	✓	✓	✓
Document – Order dimension drawing	<b>B32</b>	✓	✓	✓	✓

For legend and footnotes, see Page 3/57.

# IEC Squirrel-Cage Motors

## Non-standard motors frame size 315 and above

### Special versions

Special versions	Additional identification code -Z with order code and plain text if required	Motor type frame size			
		315	355	400	450
<b>Forced-air cooled motors with mounted separately driven fan for converter-fed operation 1PQ8</b>					
<b>1PQ8</b> Converter-fed operation					
<b>Packaging, safety notes, documentation and test certificates</b> <sup>16)</sup> (continued)					
Document – Load characteristics	<b>B37</b>	O. R.	O. R.	O. R.	O. R.
Normal inspection (routine inspection) with acceptance	<b>F01</b>	✓	✓	✓	✓
Visual acceptance and report handover with acceptance	<b>F03</b>	✓	✓	✓	✓
Temperature-rise test, without acceptance	<b>F04</b>	✓	✓	✓	✓
Temperature-rise test, with acceptance	<b>F05</b>	✓	✓	✓	✓
Noise measurement in no-load operation, no noise analysis, no acceptance	<b>F28</b>	✓	✓	✓	✓
Noise measurement in no-load operation, no noise analysis, with acceptance	<b>F29</b>	✓	✓	✓	✓
Noise measurement in no-load operation, with noise analysis, without acceptance	<b>F62</b>	✓	✓	✓	✓
Noise measurement in no-load operation, with noise analysis, with acceptance	<b>F63</b>	✓	✓	✓	✓
Recording of current and torque curves with torque metering shaft during starting, without acceptance	<b>F34</b>	–	–	–	–
Recording of current and torque curves with torque metering shaft during starting, with acceptance	<b>F35</b>	–	–	–	–
Measurement of locked-rotor torque and current, without acceptance	<b>F52</b>	–	–	–	–
Measurement of locked-rotor torque and current, with acceptance	<b>F53</b>	–	–	–	–
Type test with heat run for horizontal motors, without acceptance	<b>F82</b>	✓	✓	✓	✓
Type test with heat run for horizontal motors, with acceptance	<b>F83</b>	✓	✓	✓	✓
Type test with heat run for vertical motors, without acceptance	<b>F92</b>	✓	✓	✓	✓
Type test with heat run for vertical motors, with acceptance	<b>F93</b>	✓	✓	✓	✓

- Standard version
- Without additional charge
- This order code only determines the price of the version – Additional plain text is required.
- O. R. Possible on request
- ✓ With additional charge
- Not possible

<sup>1)</sup> Evaluation with appropriate tripping unit (see Catalog LV 1) is recommended.

<sup>2)</sup> The standard thermistors are omitted. If PTC thermistors are required as well as KTYs or PT100s, this must be specified in the order in plain text. A combination of **A12** and **A61** or **A12** and **A23** is possible on request for an additional charge.

<sup>3)</sup> Only possible in combination with the larger connection boxes 1XB1 621 or 1XB1 631 (order codes **M58** or **L00**).

<sup>4)</sup> A combination with the order codes **M88** and **M50** is not possible. Connection box 1XP1 634 can be rotated through 4 x 90°. Cable entry is from NDE or the delivery position. Dimension drawings available on request.

<sup>5)</sup> With 1PQ8 357-2 and 1PQ8 357-4, connection box 1XB1 631 is supplied in the standard version.

<sup>6)</sup> Use according to temperature class 180 (H) is not possible. All 400 V version are available on request. Due to the rated current, a larger connection box of type 1XB9 600, which is part of order code **C14**, is generally provided for frame sizes 400 (2- and 4-pole) and 450 (all no. of poles).

<sup>7)</sup> Only possible for main motor – Not possible for separately driven fan.

<sup>8)</sup> Site altitude up to 1000 m above sea level.

<sup>9)</sup> Only possible for main motor – Not possible for separately driven fan motor.

<sup>10)</sup> Explosion-protected encoders are available on request.

<sup>11)</sup> Only admissible for use in accordance with temperature class 130 (B). PTC thermistors for temperature class 130 (B) are included. For compliance with temperature class 130 (B), derating is necessary in the case of converter-fed operation in Zones 2 and 22. Derating data are available on request.

<sup>12)</sup> These motors do not have a rated voltage range stamped on the rating plate.

<sup>13)</sup> In the order, the "Speed range and torque characteristic" must be specified in plain text. A system test is necessary for  $M = \text{constant}$ .

<sup>14)</sup> Not possible for 2-pole motors and motors of vertical type of construction.

<sup>15)</sup> When ordering, specify in plain text: Voltage, frequency and circuit.

<sup>16)</sup> Type testing is also performed for converter-fed operation.

# IEC Squirrel-Cage Motors

## Non-standard motors frame size 315 and above

### Special versions

Options or order codes (supplement **-Z** is required)

Special versions	Additional identification code <b>-Z</b> with order code and plain text if required	Motor type frame size							
		315	355	400	450	315	355	400	450
<b>Self-ventilated motors with through ventilation for mains-fed and converter-fed operation</b>									
		<b>1LL8</b> Mains-fed operation				<b>1LL8</b> Converter-fed operation			
<b>Standardline</b>									
Standardline version	<b>B20</b>	–	–	–	–	–	–	–	–
<b>Motor protection</b>									
Motor protection with PTC thermistors with 6 embedded temperature sensors for alarm and tripping <sup>1)</sup>	<b>A12</b>	☐	☐	☐	☐	☐	☐	☐	☐
Motor temperature detection with embedded temperature sensor KTY 84-130 <sup>2)</sup>	<b>A23</b>	○	○	○	○	○	○	○	○
Installation of 6 PT 100 resistance thermometers in stator winding <sup>2)</sup>	<b>A61</b>	✓	✓	✓	✓	✓	✓	✓	✓
Installation of 2 PT 100 screw-in resistance thermometers (basic circuit) for rolling-contact bearings	<b>A72</b>	✓	✓	✓	✓	✓	✓	✓	✓
<b>Motor connection and connection box</b>									
Two-part plate on connection box	<b>K06</b>	✓	✓	✓	✓	O. R.	O. R.	O. R.	O. R.
Undrilled entry plate	<b>L01</b>	○	○	○	○	○	○	○	○
Connection box on RHS	<b>K09</b>	☐	☐	☐	☐	☐	☐	☐	☐
Connection box on LHS	<b>K10</b>	○	○	○	○	○	○	○	○
Connection box above (1XB1 634 connection box) <sup>3)</sup>	<b>K11</b>	✓	✓	✓	✓	✓	✓	✓	✓
Cable gland, maximum configuration	<b>K57</b>	✓	✓	✓	✓	✓	✓	✓	✓
Rotation of the connection box through 90°, entry from DE	<b>K83</b>	○	○	○	○	○	○	○	○
Rotation of the connection box through 90°, entry from NDE	<b>K84</b>	○	○	○	○	○	○	○	○
Rotation of connection box through 180°	<b>K85</b>	○	○	○	○	○	○	○	○
Larger connection box (1XB1 621 connection box)	<b>M58</b>	✓	–	–	–	☐	–	–	–
Larger connection box (1XB1 631 connection box)	<b>L00</b>	✓	☐	☐	☐	✓	☐	☐	☐
6 cables protruding, 1.5 m long	<b>L48</b>	O. R.	O. R.	O. R.	O. R.	O. R.	O. R.	O. R.	O. R.
6 cables protruding, 3 m long	<b>L49</b>	O. R.	O. R.	O. R.	O. R.	O. R.	O. R.	O. R.	O. R.
Auxiliary connection box 1XB9 016 (cast-iron)	<b>M50</b>	✓	✓	✓	✓	✓	✓	✓	✓
Auxiliary connection box 1XB3 020	<b>L97</b>	✓	✓	✓	✓	✓	✓	✓	✓
Auxiliary connection box 1XB9 014 (aluminum)	<b>M88</b>	✓	✓	✓	✓	✓	✓	✓	✓
Connection box on NDE	<b>M64</b>	✓	✓	✓	✓	✓	✓	✓	✓

For legend and footnotes, see Page 3/61.



# IEC Squirrel-Cage Motors

## Non-standard motors frame size 315 and above

### Special versions

Special versions	Additional identification code <b>-Z</b> with order code and plain text if required	Motor type frame size							
		315	355	400	450	315	355	400	450
<b>Self-ventilated motors with through ventilation for mains-fed and converter-fed operation</b>									
		<b>1LL8</b> Mains-fed operation				<b>1LL8</b> Converter-fed operation			
<b>Windings and insulation</b>									
Temperature class 155 (F), used acc. to 155 (F), with service factor (SF 1.1, SF 1.05 from frame size 400) <sup>4)</sup>	<b>C11</b>	✓	✓	✓	✓	–	–	–	–
Temperature class 155 (F), used acc. to 155 (F), with increased output (10 %, 5 % from frame size 400) <sup>4)</sup>	<b>C12</b>	✓	✓	✓	✓	–	–	–	–
Temperature class 155 (F), used acc. to 155 (F), with increased coolant temperature (55 °C, 50 °C from frame size 400) <sup>4)</sup>	<b>C13</b>	✓	✓	✓	✓	–	–	–	–
Temperature class 180 (H), used acc. to 155 (F), with service factor (SF 1.1)	<b>C14</b>	O. R.	O. R.	O. R.	O. R.	O. R.	O. R.	O. R.	O. R.
<b>Colors and paint finish</b>									
Standard finish in RAL 7030 stone gray		□	□	□	□	□	□	□	□
Standard paint finish in other colors	<b>Y53 •</b> and standard finish RAL ....	✓	✓	✓	✓	✓	✓	✓	✓
Special finish in RAL 7030 stone gray	<b>K26</b>	✓	✓	✓	✓	✓	✓	✓	✓
Special finish in other colors	<b>Y54 •</b> and special finish RAL ....	✓	✓	✓	✓	✓	✓	✓	✓
Unpainted (only cast iron parts primed)	<b>K23</b>	○	○	○	○	○	○	○	○
<b>Special technology</b>									
Mounting of brake (incl. brake of Stromag)	<b>H47</b>	–	–	–	–	–	–	–	–
Mounting of LL 861 900 220 rotary pulse encoder	<b>H70</b>	–	–	–	–	✓	✓	✓	✓
Mounting of HOG 10 D 1024 I rotary pulse encoder	<b>H73</b>	–	–	–	–	✓	✓	✓	✓
Prepared for mounting LL 861 900 220	<b>H78</b>	–	–	–	–	✓	✓	✓	✓
Prepared for mounting HOG 10 D 1024 I	<b>H80</b>	–	–	–	–	✓	✓	✓	✓
Mounting a special type of rotary pulse encoder	<b>Y70 •</b> and encoder designation	–	–	–	–	O. R.	O. R.	O. R.	O. R.
<b>Mechanical design and degrees of protection</b>									
Low-noise version for 2-pole motors with clockwise direction of rotation	<b>K37</b>	✓	○	○	○	✓	○	○	○
Low-noise version for 2-pole motors with counter-clockwise direction of rotation	<b>K38</b>	✓	○	○	○	✓	○	○	○
IP56 degree of protection (non-heavy-sea)	<b>K52</b>	–	–	–	–	–	–	–	–
Non-rusting screws (externally)	<b>M27</b>	✓	✓	✓	✓	✓	✓	✓	✓
<b>Coolant temperature and site altitude</b>									
Coolant temperature –40 to +40 °C	<b>D03</b>	–	–	–	–	–	–	–	–
Coolant temperature –30 to +40 °C	<b>D04</b>	–	–	–	–	–	–	–	–
Coolant temperature 45 °C, derating 4 % <sup>5)</sup>	<b>D11</b>	○	○	○	○	○	○	○	○
Coolant temperature 50 °C, derating 8 % <sup>5)</sup>	<b>D12</b>	○	○	○	○	○	○	○	○
Coolant temperature 55 °C, derating 13 % <sup>5)</sup>	<b>D13</b>	○	○	○	○	○	○	○	○
Coolant temperature 60 °C, derating 18 % <sup>5)</sup>	<b>D14</b>	○	○	○	○	○	○	○	○

For legend and footnotes, see Page 3/61.

# IEC Squirrel-Cage Motors

## Non-standard motors frame size 315 and above

### Special versions

Special versions	Additional identification code -Z with order code and plain text if required	Motor type frame size							
		315	355	400	450	315	355	400	450
<b>Self-ventilated motors with through ventilation for mains-fed and converter-fed operation</b>									
		<b>1LL8</b> Mains-fed operation				<b>1LL8</b> Converter-fed operation			
<b>Design in accordance with standards and specifications</b>									
Electrical according to NEMA MG1-12	<b>D30</b>	✓	✓	✓	✓	✓	✓	✓	✓
Design according to UL with "Recognition Mark"	<b>D31</b>	✓	✓	✓	✓	✓	✓	✓	✓
VIK version	<b>K30</b>	–	–	–	–	–	–	–	–
Canadian regulations (CSA)	<b>D40</b>	✓	✓	✓	✓	✓	✓	✓	✓
<b>Designs for Zones 2 and 22 according to ATEX</b>									
Design for Zone 2 for mains-fed operation Ex nA II T3 to IEC/EN 60079-15	<b>M72</b>	–	–	–	–	–	–	–	–
Design for Zone 2 for converter-fed operation, derating Ex nA II T3 to IEC/EN 60079-15	<b>M73</b>	–	–	–	–	–	–	–	–
Design for Zone 22 for non-conducting dust (IP55) for mains-fed operation	<b>M35</b>	–	–	–	–	–	–	–	–
Design for Zone 22 for non-conducting dust (IP55) for converter-fed operation	<b>M39</b>	–	–	–	–	–	–	–	–
Stamping of Ex nA II on VIK rating plate	<b>C27</b>	–	–	–	–	–	–	–	–
<b>Bearings and lubrication</b>									
Measuring nipple for SPM shock pulse measurement for bearing inspection	<b>G50</b>	✓	✓	✓	✓	✓	✓	✓	✓
Bearing design for increased cantilever forces	<b>K20</b>	–	–	–	–	–	–	–	–
<b>Balance and vibration quantity</b>									
Vibration quantity level B	<b>K02</b>	✓	✓	✓	✓	✓	✓	✓	✓
Full key balancing	<b>L68</b>	✓	✓	✓	✓	✓	✓	✓	✓
<b>Shaft and rotor</b>									
Second standard shaft extension <sup>b)</sup>	<b>K16</b>	✓	✓	✓	✓	✓	✓	✓	✓
Shaft extension with standard dimensions, without featherkey way	<b>K42</b>	✓	✓	✓	✓	✓	✓	✓	✓
Non-standard cylindrical shaft extension	<b>Y55 •</b> and identification code	✓	✓	✓	✓	✓	✓	✓	✓
<b>Heating and ventilation</b>									
Metal external fan	<b>K35</b>	✓	✓	✓	✓	✓	✓	✓	✓
Anti-condensation heaters for 230 V	<b>K45</b>	✓	✓	✓	✓	✓	✓	✓	✓
Anti-condensation heaters for 115 V	<b>K46</b>	✓	✓	✓	✓	✓	✓	✓	✓
Sheet metal fan cover	<b>L36</b>	□	□	□	□	□	□	□	□
<b>Rating plate and extra rating plates</b>									
Second rating plate, loose	<b>K31</b>	✓	✓	✓	✓	✓	✓	✓	✓
Extra rating plate or rating plate with deviating rating plate data	<b>Y80 •</b> and identification code	✓	✓	✓	✓	✓	✓	✓	✓
Extra rating plate with identification code	<b>Y82 •</b> and identification code	✓	✓	✓	✓	✓	✓	✓	✓
<b>Packaging, safety notes, documentation and test certificates <sup>7)</sup></b>									
Document – Electrical data sheet	<b>B31</b>	✓	✓	✓	✓	✓	✓	✓	✓
Document – Order dimension drawing	<b>B32</b>	✓	✓	✓	✓	✓	✓	✓	✓
Document – Load characteristics	<b>B37</b>	O. R.	O. R.	O. R.	O. R.	O. R.	O. R.	O. R.	O. R.

For legend and footnotes, see Page 3/61.

# IEC Squirrel-Cage Motors

## Non-standard motors frame size 315 and above

### Special versions

Special versions	Additional identification code -Z with order code and plain text if required	Motor type frame size							
		315	355	400	450	315	355	400	450
<b>Self-ventilated motors with through ventilation for mains-fed and converter-fed operation</b>									
		<b>1LL8</b> Mains-fed operation				<b>1LL8</b> Converter-fed operation			
<b>Packaging, safety notes, documentation and test certificates <sup>7)</sup></b> (continued)									
Standard test (routine test) with acceptance	<b>F01</b>	✓	✓	✓	✓	✓	✓	✓	✓
Visual acceptance and report handover with acceptance	<b>F03</b>	✓	✓	✓	✓	✓	✓	✓	✓
Temperature-rise test, without acceptance	<b>F04</b>	✓	✓	✓	✓	✓	✓	✓	✓
Temperature-rise test, with acceptance	<b>F05</b>	✓	✓	✓	✓	✓	✓	✓	✓
Noise measurement in no-load operation, no noise analysis, no acceptance	<b>F28</b>	✓	✓	✓	✓	✓	✓	✓	✓
Noise measurement in no-load operation, no noise analysis, with acceptance	<b>F29</b>	✓	✓	✓	✓	✓	✓	✓	✓
Noise measurement in no-load operation, with noise analysis, without acceptance	<b>F62</b>	✓	✓	✓	✓	✓	✓	✓	✓
Noise measurement in no-load operation, with noise analysis, with acceptance	<b>F63</b>	✓	✓	✓	✓	✓	✓	✓	✓
Recording of current and torque curves with torque metering shaft during starting, without acceptance	<b>F34</b>	✓	✓	✓	✓	–	–	–	–
Recording of current and torque curves with torque metering shaft during starting, with acceptance	<b>F35</b>	✓	✓	✓	✓	–	–	–	–
Measurement of locked-rotor torque and current, without acceptance	<b>F52</b>	✓	✓	✓	✓	–	–	–	–
Measurement of locked-rotor torque and current, with acceptance	<b>F53</b>	✓	✓	✓	✓	–	–	–	–
Type test with heat run for horizontal motors, without acceptance	<b>F82</b>	✓	✓	✓	✓	✓	✓	✓	✓
Type test with heat run for horizontal motors, with acceptance	<b>F83</b>	✓	✓	✓	✓	✓	✓	✓	✓
Type test with heat run for vertical motors, without acceptance	<b>F92</b>	✓	✓	✓	✓	✓	✓	✓	✓
Type test with heat run for vertical motors, with acceptance	<b>F93</b>	✓	✓	✓	✓	✓	✓	✓	✓

- Standard version
- Without additional charge
- This order code only determines the price of the version – Additional plain text is required.
- , R. Possible on request
- ✓ With additional charge
- Not possible

<sup>1)</sup> Evaluation with appropriate tripping unit (see Catalog LV 1) is recommended.

<sup>2)</sup> The standard thermistors are omitted. If PTC thermistors are required as well as KTYs or PT100s, this must be specified in the order in plain text. A combination of **A12** and **A61** or **A12** and **A23** is possible on request for an additional charge.

<sup>3)</sup> A combination with the order codes **M88** and **M50** is not possible. Connection box 1XP1 634 can be rotated through 4 x 90°. Cable entry is from NDE or the delivery position. Dimension drawings available on request.

<sup>4)</sup> Use according to temperature class 180 (H) is not possible. All 400 V version are available on request. Due to the rated current, a larger connection box of type 1XB9 600, which is part of order code **C14**, is generally provided for frame sizes 400 (2- and 4-pole) and 450 (all no. of poles).

<sup>5)</sup> Site altitude 1000 m above sea level

<sup>6)</sup> Please inquire in the case of 2-pole motors and motors in vertical type of construction.

<sup>7)</sup> Type testing is also performed for converter-fed operation.

# IEC Squirrel-Cage Motors

## Non-standard motors frame size 315 and above

### Accessories

#### Overview

##### *Slide rails with fixing bolts and tensioning screws to DIN 42923*

Slide rails are used to tension the belt of a machine easily and conveniently when a belt tightener is not available. They are fixed to the base using stone bolts or foundation blocks.

The assignment of slide rails to motor size can be found in DIN 42923. For motors of frame sizes 335 to 450, there are no standardized slide rails (please inquire).

Available from:

Lütgert & Co. GmbH  
Postfach 42 51  
33276 Gütersloh, Germany  
Tel. +49 (0)5241-7407-0  
Fax +49 (0)5241-7407-90

<http://www.luetgert-antriebe.de>  
e-mail: [info@luetgert-antriebe.de](mailto:info@luetgert-antriebe.de)

##### *Foundation block acc. to DIN 799*

The foundation blocks are inserted into the stone foundation and embedded in concrete. They are used for fixing machines of medium size, slide rails, pedestal bearings, baseframes, etc. After the fixing bolts have been unscrewed, the machine can be dragged without it having to be lifted.

When the machine is initially installed, the foundation block that is bolted to the machine (without washers) and fitted with tapered pins is not embedded with concrete until the machine has been fully aligned. In this case, the machine is positioned 2 to 3 mm lower. The difference in shaft height is compensated by inserting shims on final installation. The tapered pins safeguard the exact position of the machine when it is repeatedly removed and replaced without the need for realignment.

Available from:

Lütgert & Co. GmbH  
Postfach 42 51  
33276 Gütersloh, Germany  
Tel. +49 (0)5241-7407-0  
Fax +49 (0)5241-7407-90

<http://www.luetgert-antriebe.de>  
e-mail: [info@luetgert-antriebe.de](mailto:info@luetgert-antriebe.de)

##### *Taper pins to DIN 258 with threaded ends and constant taper lengths*

Taper pins are used for components that are repeatedly removed. The drilled hole is ground conical using a conical reamer until the pin can be pushed in by hand until the cone shoulder lies 3 to 4 mm above the rim of the hole.

It can then be driven in using a hammer until it is correctly seated. The pin is removed from the drilled hole by screwing on the nut and tightening it.

Standardized taper pins are available from general engineering suppliers.

Available from:

Otto Roth GmbH & Co. KG  
Rutesheimer Straße 22  
70499 Stuttgart, Germany  
Tel. +49 (0)711-13 88-0  
Fax +49 (0)711-13 88-233

<http://www.ottoroth.de>  
e-mail: [info@ottoroth.de](mailto:info@ottoroth.de)

##### *Couplings*

The motor from Siemens is connected to the machine or gear unit through a coupling. Flender is an important coupling manufacturer with a wide range of products. For standard applications, Siemens recommends that elastic couplings of Flender types N-Eupex and Rupex or torsionally rigid couplings of types Arpex and Zapex are used. For special applications, Fludex and Elpex-S couplings are recommended. These coupling types are suitable for use in areas subject to explosion hazards and are offered with declaration of conformity and type test certificate according to directive 94/9/EU.

Source of supply:

Siemens contact partner – ordering from Catalog  
Siemens MD 10.1 „FLENDER Standard Couplings“

or

A. Friedr. Flender AG  
Kupplungswerk Mussum  
Industriepark Bocholt  
Schlavenhorst 100  
46395 Bocholt, Germany  
Tel. +49 (0)2871-92 2185  
Fax +49 (0)2871-92 2579

<http://www.flender.com>  
e-mail: [couplings@flender.com](mailto:couplings@flender.com)

#### More information

##### *Spare motors and repair parts*

- Supply commitment for spare motors and repair parts following delivery of the motor
  - For up to 5 years, in the event of total motor failure, Siemens will supply a comparable motor with regard to the mounting dimensions and functions (the type series may vary).
  - Repair parts will be supplied for up to 5 years.
  - For up to 10 years, Siemens will provide information and will, if necessary, supply documentation for repair parts.
- When repair parts are ordered, the following details must be provided:
  - Designation and part number
  - Order No. and factory number of the motor

Example for an order for a fan cowl 1LA8, frame size 315, 4-pole:

**Fan cowl No. 12.01,  
1LA8 315-4AB60, factory No. J1172515010001**

- For bearing types, see the “Introduction”.
- For standard components, a supply commitment does not apply.
- Support – Hotline  
In Germany  
Tel.: 01 80/5 05 04 48

You will find telephone numbers for other countries on our Internet site:

<http://www.siemens.com/automation/service&support>

# IEC Squirrel-Cage Motors

## Non-standard motors frame size 315 and above

### Dimensions

#### Overview

##### Overall dimensions

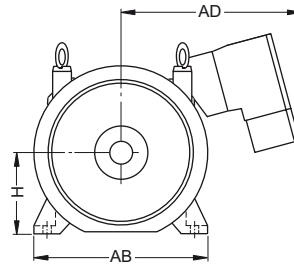
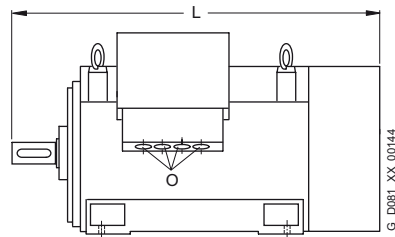

Frame size	Type	Number of poles	Dimensions			
			L	AD	H	AB
315	1LA8	2	1380	570	315	680
	1LA8	4, 6, 8	1410	570	315	680
	1LA8	4, 6, 8 <sup>1)</sup>	1430	570	315	680
	1PQ8	2	1742	570	315	680
	1PQ8	4, 6, 8	1772	570	315	680
	1PQ8	4 <sup>1)</sup>	1792	570	315	680
	1LL8	2	1380	662	315	680
	1LL8	4, 6, 8	1410	662	315	680
355	1LA8	2	1605	710	355	780
	1LA8	4, 6, 8	1635	710	355	780
	1LA8	4, 6, 8 <sup>1)</sup>	1699	710	355	780
	1PQ8	2	1971	690	355	780
	1PQ8	4, 6, 8	2001	690	355	780
	1PQ8	4, 6, 8 <sup>1)</sup>	2065	690	355	780
	1LL8	2	1635	840	355	780
	1LL8	4, 6, 8	1675	840	355	780

Frame size	Type	Number of poles	Dimensions			
			L	AD	H	AB
400	1LA8	2	1793	865	400	860
	1LA8	4, 6, 8	1833	865	400	860
	1PQ8	2	2148	865	400	860
	1PQ8	4, 6, 8	2188	865	400	860
	1LL8	2	1793	865	400	860
	1LL8	4, 6, 8	1833	865	400	860
450	1LA8	2	1953	900	450	980
	1LA8	4, 6, 8	1993	900	450	980
	1PQ8	2	2308	900	450	980
	1PQ8	4, 6, 8	2348	900	450	980
	1LL8	2	1953	900	450	980
	1LL8	4, 6, 8	2033	900	450	980

For dimension "O", see "Introduction" under "Connection boxes".

##### Notes on the dimensions

■ Dimension drawings according to DIN EN 50347 and IEC 60072.

##### ■ Fits

The shaft extensions specified in the dimension tables (DIN 748) and centering spigot diameters (DIN EN 50347) are machined with the following fits:

Dimension designation	ISO fit	DIN ISO 286-2
D, DA	over 50	m6
N	over 250	h6
F, FA		h9
K		H17
S	Flange (FF)	H17

The drilled holes of couplings and belt pulleys should have an ISO fit of at least H7.

##### ■ Dimension tolerances

For the following dimensions, the permissible deviations are given below:

Dimension designation	Dimension	Permitted deviation
H	over 250	- 1.0
E, EA		- 0.5

Keyways and feather keyways (dimensions GA, GC, F and FA) are made in compliance with DIN 6885 Part 1.

■ All dimensions are specified in mm.

<sup>1)</sup> With bearings for increased cantilever forces: Dimensions available on request.

# IEC Squirrel-Cage Motors

## Non-standard motors frame size 315 and above

### Dimensions

#### Dimensional drawings

Cast-iron series 1LA8, frame sizes 315 to 450

Type of construction IM B3

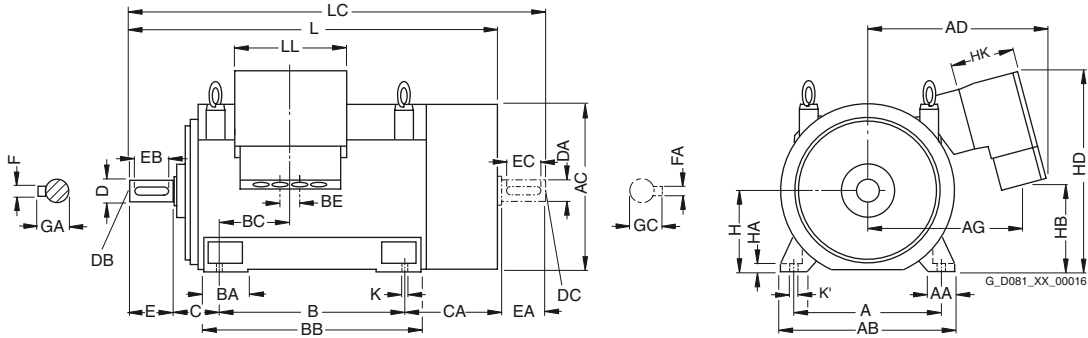

Type of construction IM V1

For flange dimensions, see Page 3/70 (Z = the number of retaining holes)

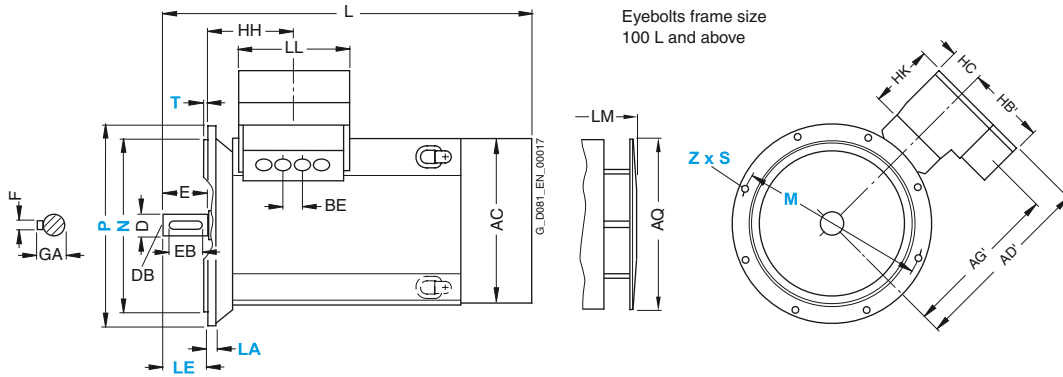

#### Connection box position

##### Basic version

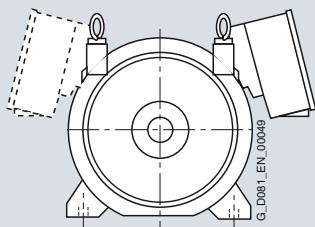

Cable entry: bottom  
Console: 0 degrees  
Order code: -

##### Special versions

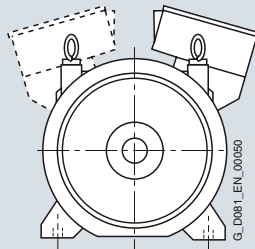

Cable entry: top  
Console: 180 degrees  
Order code: K85

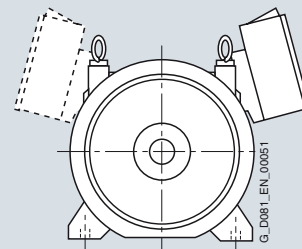

Cable entry: top  
Console: 0 degrees  
Order code: plain text

With cable entry from above, protection against rain and other adverse weather conditions must be provided.

For motor		Dimension designation acc. to IEC																									
Frame size	Type	Number of poles	A	AA	AB	AC <sup>1)</sup>	AD	AD'	AG	AG'	AQ	B	BA	BB	BC	BE	C	CA	H	HA	HB	HB'	HC				
315	1LA8 31	2 4, 6, 8 4, 6, 8 <sup>2)</sup>	560	120	680	710	570	582	474	481	670	630	180	780	195	140	180 180 200	435	315	28	404	217	162				
355	1LA8 35	2 4, 6, 8	630	150	780	790	690	697	597	593	750	800	220	980	185	135	200	470	355	35	431	290	165				
	1LA8 357	2, 4					829	875	739	745							100							200	359	395	175
	1LA8 35	4, 6, 8 <sup>2)</sup>					690	697	597	593							135							224	431	290	165
400	1LA8 40	2 4, 6, 8	710	150	860	880	865	925	775	795	850	900	220	1080	186	100	224	506	400	35	439	395	175				
450	1LA8 45	2 <sup>3)</sup>	800	180	980	970	900	975	810	845	950	1000	260	1220	170	100	250	540	450	42	525	395	175				
		4, 6, 8																									

<sup>1)</sup> Measured across the bolt heads (not in the flattened area of the fan cowl).

<sup>2)</sup> With bearings for increased cantilever forces. – No second shaft extension possible.

<sup>3)</sup> Only at 50 Hz.

# IEC Squirrel-Cage Motors

## Non-standard motors frame size 315 and above

### Dimensions

#### Dimensional drawings

Cast-iron series 1LA8, frame sizes 315 to 450

#### Type of construction IM B35

For flange dimensions, see Page 3/70 (Z = the number of retaining holes)

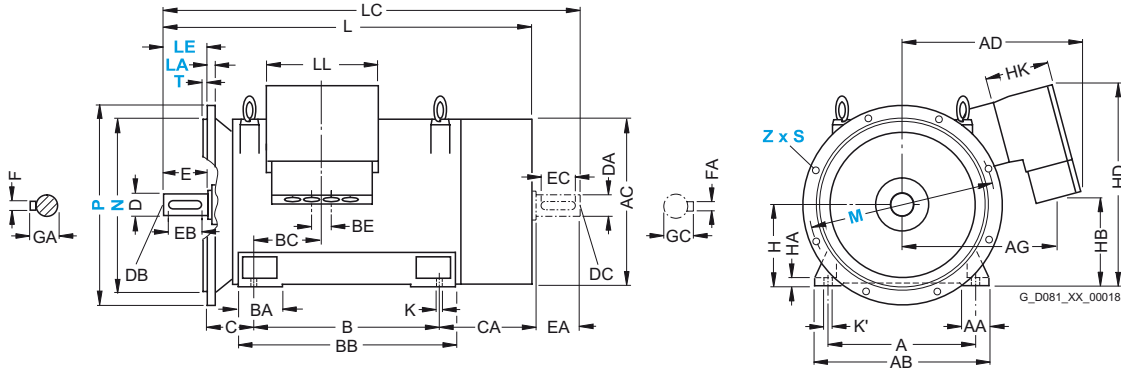

3

#### Connection box position

##### Special versions

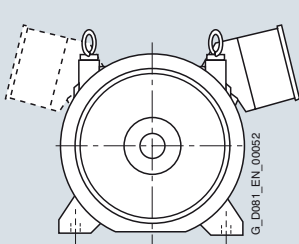

Cable entry: DE / NDE  
Console: 0 degrees  
Order code: K83/K84

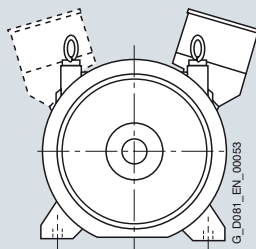

Cable entry: DE / NDE  
Console: 180 degrees  
Order code: plain text

For motor Frame size	Type	Number of poles	Dimension designation acc. to IEC								DE shaft extension					NDE shaft extension						
			HD	HK	K	K'	L	LC	LL	LM	D	DB	E	EB	F	GA	DA	DC	EA	EC	FA	GC
315	1LA8 31 .	2	783	170	26	33	1380	1495	308	1510	65	M20	140	125	18	69	50	M16	110	100	14	53.5
		4, 6, 8					1410	1555	1540	85	M20	170	140	22	90	70	M20	140	125	20	74.5	
355	1LA8 35 .	2	896	229	33	40	1605	1750	330	1745	75	M20	140	125	20	79.5	60	M20	140	125	18	64
		4, 6, 8					1635	1810	1775	95	M24	170	140	25	100	80	170	140	22	85		
		2, 4					945	320			554											
400	1LA8 40 .	2	1025	320	33	40	1793	1940	554	1943	80	M20	170	140	22	85	70	M20	140	125	20	74.5
		4, 6, 8					1833	2010	1983	110	M24	210	180	28	116	90	M24	170	140	25	95	
		2, 4					945	320			554											
450	1LA8 45 .	2 <sup>2)</sup>	1111	320	39	47	1953	2100	554	2103	90	M24	170	140	25	95	75	M20	140	125	20	79.5
		4, 6, 8					1993	2210	2143	120		210	180	32	127	100	M24	210	180	28	106	

<sup>1)</sup> With bearings for increased cantilever forces. – No second shaft extension possible.

<sup>2)</sup> Only at 50 Hz.

# IEC Squirrel-Cage Motors

## Non-standard motors frame size 315 and above

### Dimensions

#### Dimensional drawings

Cast-iron series 1PQ8, frame sizes 315 to 450

#### Type of construction IM B3

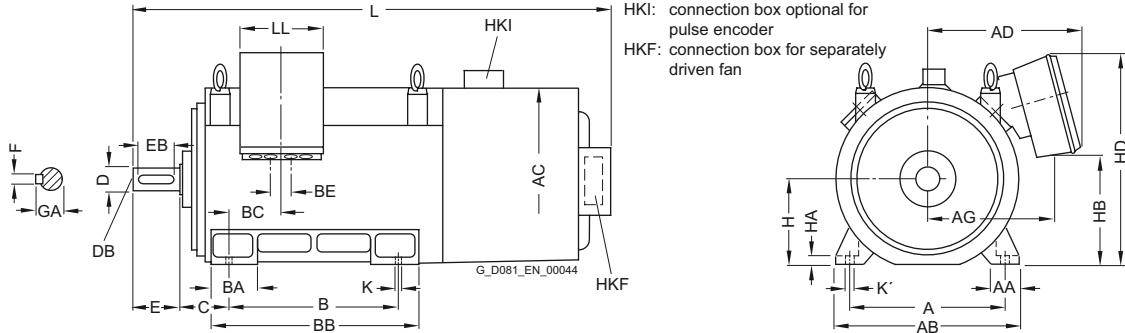

#### Type of construction IM V1

For flange dimensions, see Page 3/70 (Z = the number of retaining holes)

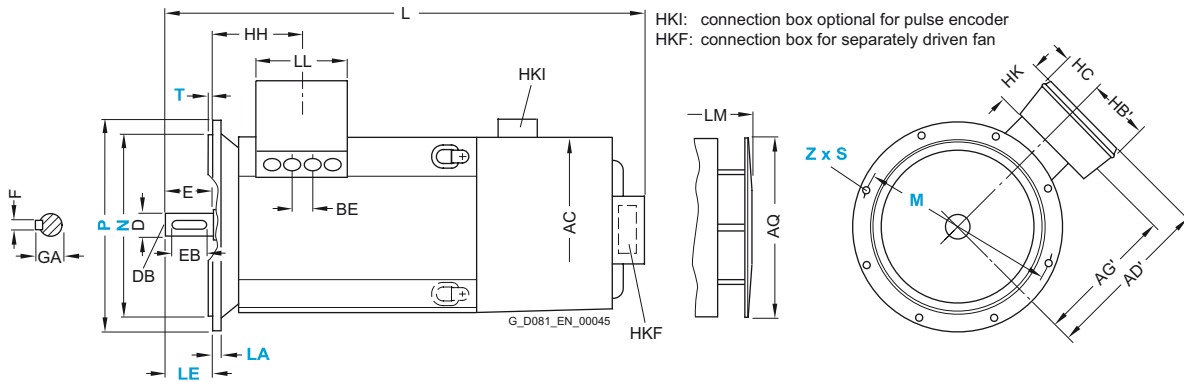

#### Connection box position

Basic version	Special versions	
Cable entry: bottom Console: 0 degrees Order code: -	Cable entry: top Console: 180 degrees Order code: K85	Cable entry: top Console: 0 degrees Order code: plain text

With cable entry from above, protection against rain and other adverse weather conditions must be provided.

For motor	Dimension designation acc. to IEC																	
Frame size	Type	Number of poles	A	AA	AB	AC <sup>1)</sup>	AD	AD'	AG	AG'	AQ	B	BA	BB	BC	BE	C	
315	1PQ8 31.	2	560	120	680	710	570	582	474	481	750	630	180	780	195	140	180	
		4, 6, 8															180	
		4, 6, 8 <sup>2)</sup>															200	
355	1PQ835. 35.	2	630	150	780	790	690	697	597	593	850	800	220	980	185	135	200	
		4, 6, 8															200	
		2, 4															100	
	1PQ8357	2, 4					829	875	739	745						100	200	
	1PQ835	4, 6, 8 <sup>2)</sup>					670	697	597	593							135	224
400	1PQ8 40.	2	710	150	860	880	865	925	775	795	950	900	220	1080	186	100	224	
	4, 6, 8	224																
450	1PQ8 45.	2 <sup>3)</sup>	800	180	980	970	900	980	810	845	950	1000	260	1220	170	100	250	
		4, 6, 8															250	

<sup>1)</sup> Measured across the bolt heads (not in the flattened area of the fan cowl).

<sup>2)</sup> With bearings for increased cantilever forces.

<sup>3)</sup> Only at 50 Hz.

3



# IEC Squirrel-Cage Motors

## Non-standard motors frame size 315 and above

### Dimensions

#### Dimensional drawings

Cast-iron series 1PQ8, frame sizes 315 to 450

#### Type of construction IM B35

For flange dimensions, see Page 3/70 (Z = the number of retaining holes)

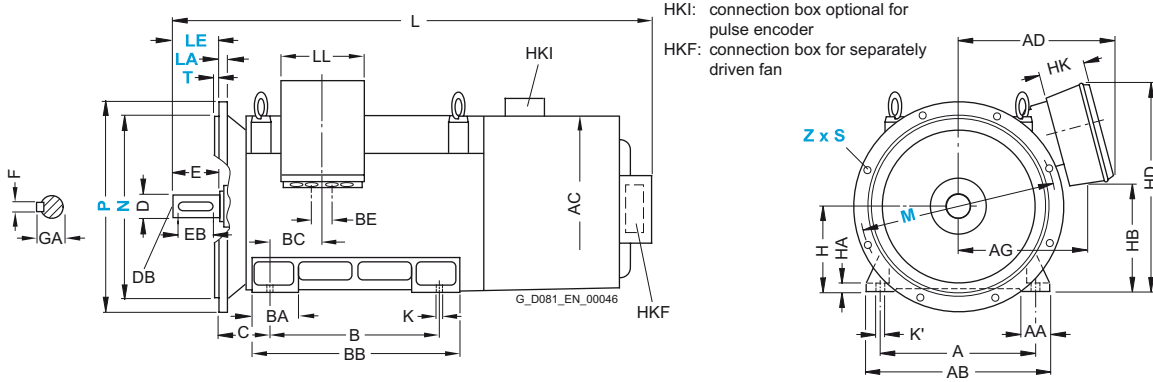

3

#### Connection box position

##### Special versions

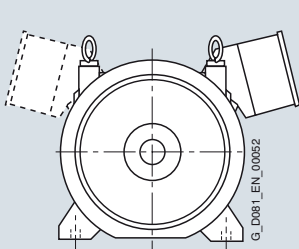

Cable entry: DE / NDE  
 Console: 0 degrees  
 Order code: K83/K84

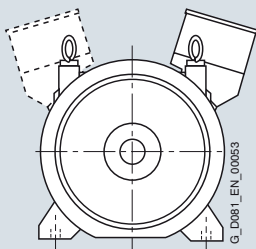

Cable entry: DE / NDE  
 Console: 180 degrees  
 Order code: plain text

For motor		Dimension designation acc. to IEC													DE shaft extension					
Frame size	Type	Number of poles	H	HA	HB	HB'	HC	HD	HK	K	K'	L	LL	LM	D	DB	E	EB	F	GA
315	1PQ8 31.	2	315	28	404	217	162	783	170	26	33	1742	308	1765	65	M20	140	125	18	69
		4, 6, 8													85	M20	170	140	22	90
		4, 6, 8 <sup>1)</sup>													95	M24	170	140	25	100
355	1PQ8 35.	2	355	35	431	290	165	896	229	33	40	1971	330	2005	75	M20	140	125	20	79.5
		4, 6, 8													95	M24	170	140	25	100
		2, 4																		
	1PQ8 357	2, 4			359	395	175	945	320				554							
	1PQ8 35.	4, 6, 8 <sup>1)</sup>										2065		2099	100	M24	210	180	28	106
400	1PQ8 40.	2	400	35	440	400	175	1025	320	33	40	2148	554	2182	80	M20	170	140	22	85
		4, 6, 8													110	M24	210	180	28	116
450	1PQ8 45.	2 <sup>2)</sup>	450	42	525	400	175	1111	320	39	47	2308	554	2340	90	M24	170	140	25	95
		4, 6, 8													120		210	180	32	127

1) With bearings for increased cantilever forces.  
 2) Only at 50 Hz.

# IEC Squirrel-Cage Motors

## Non-standard motors frame size 315 and above

### Dimensions

#### Dimensional drawings

Cast-iron series 1LL8, frame sizes 315 to 450

Type of construction IM B3

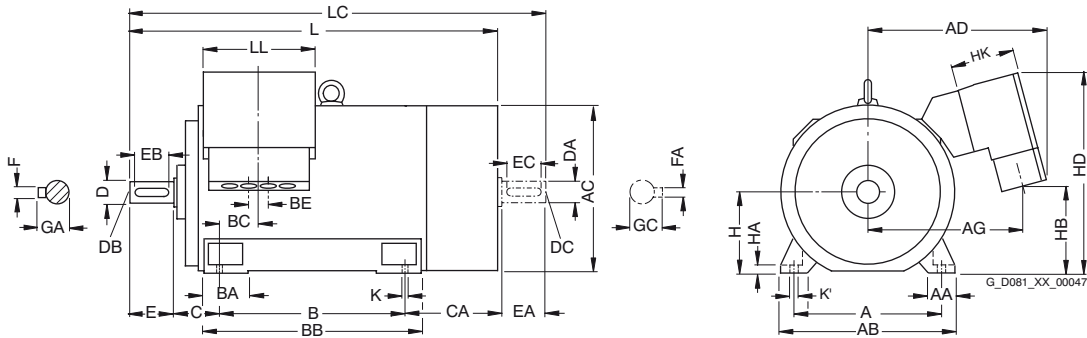

3

#### Connection box position

##### Basic version

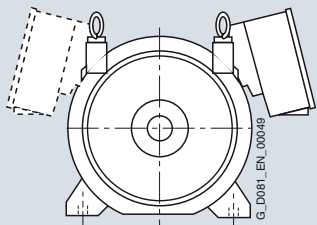

Cable entry: bottom  
Console: 0 degrees  
Order code: -

##### Special versions

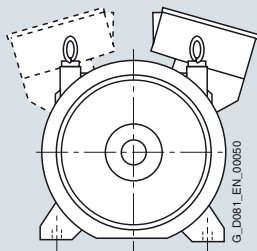

Cable entry: top  
Console: 180 degrees  
Order code: K85

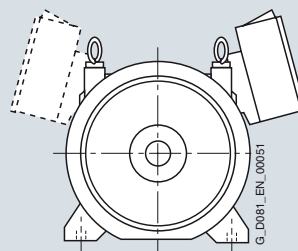

Cable entry: top  
Console: 0 degrees  
Order code: plain text

For motor			Dimension designation acc. to IEC																
Frame size	Type	Number of poles	A	AA	AB	AC <sup>1)</sup>	AD	AD'	AG	AG'	AQ	B	BA	BB	BC	BE	C	CA	
315	1LL8 31.	2 4, 6, 8	560	120	680	710	662	- 660	569	- 560	670	630	180	780	195	110	180	435	
355	1LL8 35.	2 4, 6, 8	630	150	780	790	829	- 880	739	- 745	750	800	220	980	185	135	200	470	
400	1LL8 40.	2 4, 6, 8	710	150	860	880	865	- 930	775	- 795	850	900	220	1080	186	100	224	506	
450	1LL8 45.	2 <sup>2)</sup> 4, 6, 8	800	180	980	970	900	- 980	810	- 845	950	1000	260	1220	170	100	250	540	

1) Measured across the bolt heads.

2) Only at 50 Hz.

# IEC Squirrel-Cage Motors

## Non-standard motors frame size 315 and above

### Dimensions

#### Dimensional drawings

Cast-iron series 1LL8, frame sizes 315 to 450

#### Type of construction IM V1

For flange dimensions, see Page 3/70 (Z = the number of retaining holes)

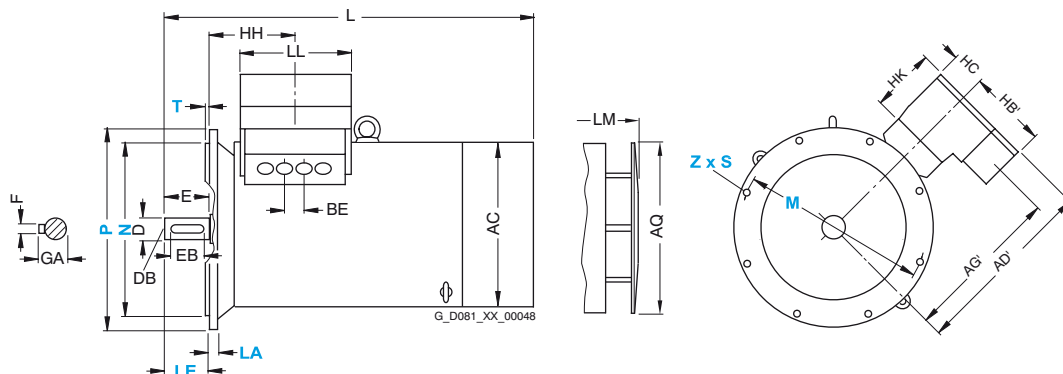

3

#### Connection box position

##### Special versions

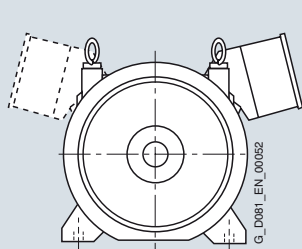

Cable entry: DE / NDE  
Console: 0 degrees  
Order code: K83/K84

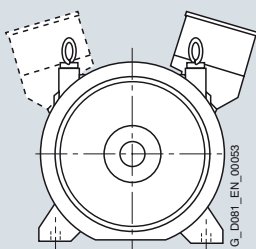

Cable entry: DE / NDE  
Console: 180 degrees  
Order code: plain text

For motor		Dimension designation acc. to IEC															DE shaft extension				
Frame size	Type	Number of poles	H	HA	HB	HB'	HD	HK	K	K'	L	LC	LL	LM	D	DB	E	EB	F	GA	
315	1LL8 31.	2	315	28	363	–	828	229	26	33	1380	1495	330	1510	70	M20	140	125	20	74.5	
		4, 6, 8				290									90	M24	170	140	25	95	
355	1LL8 35.	2	355	35	359	–	945	320	33	40	1605	1750	554	1775	80	M20	170	140	22	85	
		4, 6, 8				400									110	M24	210	180	28	116	
400	1LL8 40.	2	400	35	439	–	1025	320	33	40	1793	1940	554	1943	85	M20	170	140	22	90	
		4, 6, 8				400									120	M24	210	180	32	127	
450	1LL8 45.	2 <sup>1)</sup>	450	42	525	–	1111	320	39	47	1953	2100	554	2143	90	M24	170	140	25	95	
		4, 6, 8				400									130	M24	250	220	32	137	

<sup>1)</sup> Only at 50 Hz.

# IEC Squirrel-Cage Motors

## Non-standard motors frame size 315 and above

### Dimensions

#### Dimensional drawings

##### Flange dimensions

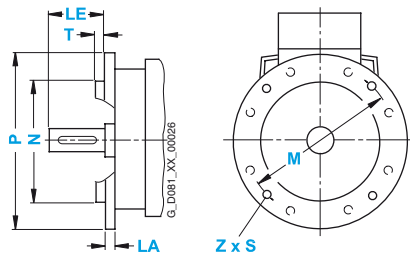

Frame size	Type of construction	Flange type	Flange with through holes (FF/A)		Dimension designation acc. to IEC							
			According to DIN EN 50347	Acc. to DIN 42948	LA	LE	M	N	P	S	T	Z
<b>315</b> 2-pole 4-pole to 8-pole	IM B35, IM V1	Flange	–	–	25	140 170	740	680	800	22	6	8
<b>355</b> 2-pole 4-pole to 8-pole	IM B35, IM V1	Flange	–	–	25	140 170	840	780	900	22	6	8
<b>400</b> 2-pole 4-pole to 8-pole	IM B35, IM V1	Flange	–	–	28	170 210	940	880	1000	22	6	8
<b>450</b> 2-pole 4-pole to 8-pole	IM B35, IM V1	Flange	–	–	30	170 210	1080	1000	1150	26	6	8

3

## Explosion-proof motors



4/2	<b>Orientation</b>	4/70	<b>Self-ventilated motors in Zones 2, 21, 22 with type of protection “n” or protection against dust explosions</b>
4/2	Overview	4/70	<b>Cast-iron series 1LG6</b>
4/3	Benefits	4/70	Selection and ordering data
4/3	Application	4/80	<b>Self-ventilated motors in Zones 2, 22 with type of protection “n” or protection against dust explosions</b>
4/3	Technical specifications	4/80	<b>Cast-iron series 1LA8</b>
4/11	Selection and ordering data	4/80	Selection and ordering data
4/13	More information	4/80	<b>Forced-air cooled motors in Zones 2, 22 with type of protection “n” or protection against dust explosions</b>
4/18	<b>Self-ventilated motors in Zone 1 with type of protection “e”</b>	4/80	<b>Cast-iron series 1PQ8</b>
	<b>Aluminum series 1MA7</b>	4/81	<b>Special versions</b>
4/18	Selection and ordering data	4/81	Overview
4/22	<b>Self-ventilated motors in Zone 1 with type of protection “e”</b>	4/84	Selection and ordering data
	<b>Cast-iron series 1MA6</b>	4/84	• Voltages
4/22	Selection and ordering data	4/90	• Types of construction
4/34	<b>Self-ventilated motors in Zone 1 with type of protection “de”</b>	4/93	• Options
	<b>Cast-iron series 1MJ6 and 1MJ7</b>	4/125	<b>Accessories</b>
4/34	Selection and ordering data	4/125	Overview
4/42	<b>Self-ventilated motors in Zones 2, 21, 22 with type of protection “n” or protection against dust explosions</b>	4/126	More information
	<b>Aluminum series 1LA7 and 1LA5</b>	4/127	<b>Dimensions</b>
4/42	Selection and ordering data	4/127	Overview
4/50	<b>Self-ventilated motors in Zones 2, 21, 22 with type of protection “n” or protection against dust explosions</b>	4/129	More information
	<b>Aluminum series 1LA9</b>	4/130	Dimensional drawings
4/50	Selection and ordering data		
4/62	<b>Self-ventilated motors in Zones 2, 21, 22 with type of protection “n” or protection against dust explosions</b>		
	<b>Cast-iron series 1LA6 and 1LG4</b>		
4/62	Selection and ordering data		

# IEC Squirrel-Cage Motors

## Explosion-proof motors

### Orientation

#### Overview



Explosion-protected equipment are designed such that an explosion can be prevented when they are used properly.

The explosion-protected equipment can be designed in accordance with various types of protection.

The **local** conditions must be subdivided into specified zones by the user with the assistance of the responsible authorities in accordance with the frequency of occurrence of an explosion hazard. Device (equipment) categories are assigned to these zones. The zones are then subdivided into possible types of protection and therefore into possible equipment (product) types.

Our product range contains motors in the following types of protection:

- “Increased safety” Ex e II
- “Explosion-proof enclosure” Ex de IIC/Ex d IIC
- “Non-sparking” Ex nA II
- “Areas protected against dust explosions in Zones 21 and 22”

The table below “Overview of explosion-proof motors” contains a complete overview of our products, their types of protection and the assignment of motor types to categories. It is important to note that depending on whether the motor is used for converter-fed operation or mains-fed operation, different order codes are required for unique selection of the required product.

In many industrial sectors as well as in domestic life, explosion protection or explosion hazards are ever-present, e.g. in the chemicals industry, in refineries, on drilling platforms, at petrol stations, in feed manufacturing and in sewage treatment plants.

The risk of explosion is always present when gases, fumes, mist or dust are mixed with oxygen in the air in an explosive ratio close to sources of ignition that are able to release the so-called minimum ignition energy.

#### Overview of explosion-proof motors

Section	Category	Zone	Frequency of occurrence of the Ex atmosphere	Degree of protection	Temperature class	Degree of protection	Standard	Motor type (Pos. 1-4 of Order No.)	Operation	Order code	Utilization according to temperature class
Gas and Fumes (G)	1G	0	Continuously or long-term	Not common practice with low-voltage motors							
	2G	1	Infrequently	Ex de IIC <sup>1)</sup> (explosion-proof enclosure)	T1 – T4	IP55	IEC/EN 60 079-0 IEC/EN 60 079-1	1MJ6/7	Mains	–	130 (B)
				Ex e II (increased safety)	T1 – T3	IP55	IEC/EN 60 079-0 IEC/EN 60 079-7	1MA6 1MA7	Mains	–	130 (B)/ 155 (F)
	3G	2	Rarely or briefly	Ex nA II (non sparking)	T1 – T3	IP55	IEC/EN 60079-15	1LA6	Mains	M72	130 (B)
1LA7 1LA8, 1PQ8 <sup>2)</sup> 1LA9 1LG4/6								Converter	M73		
Dust (D)	1D	20	Continuously or long-term	Not common practice with low-voltage motors							
	2D	21	Infrequently	Conductive and non-conductive dust	Max. housing temperature T 125 °C	IP65	IEC/EN 61241	1LA5	Mains	M34	130 (B)
								1LA6 1LA7	Converter	M38	
3D	22	Rarely or briefly	Non-conductive dust		IP55		1LA8 <sup>3)</sup> , 1PQ8 <sup>2)</sup> 1LA9 1LG4/6	Mains	M35		
									Converter	M39	

<sup>1)</sup> Highest explosion group IIC includes IIB and IIA.

<sup>2)</sup> 1PQ8 is not possible for Zones 21 and 22; Zone 2 for 1PQ8 available on request. Utilization according to temperature class 155 (F).

<sup>3)</sup> 1LA8 only available for Zone 22 (order codes M35, M39). Utilization according to temperature class 155 (F).

### Benefits

The explosion-proof motors from Siemens offer the user numerous advantages:

- The motors are designed in accordance with Directive 94/9/EU (ATEX 95 previously ATEX 100a). As product supplier, Siemens accepts responsibility for compliance with the applicable product standards for the selected equipment.
- By using this product, the plant operating company satisfies Directive 1999/92/EU in accordance with Appendix II B (ATEX 137 previously ATEX 118a). The plant manufacturer or plant operating company is responsible for correct selection and proper usage of the equipment.

- Comprehensive series of explosion-proof motors for protection against gas and dust.
- Individual versions of motors are possible thanks to the numerous catalog options.
- Further special versions are possible on request.
- Certificates are available for a defined spectrum of Siemens motors/converters.

### Application

The explosion-proof motors are used in the following sectors to prevent explosion hazards that result in serious injury to persons and severe damage to property.

- Chemical and petrochemical industry
- Production of mineral oil and gas
- Gas works
- Gas supply companies
- Petrol stations
- Coking plants
- Mills (e.g. corn, solids)
- Sewage treatment plants
- Wood processing (e.g. sawdust, tree resin)
- Other industries subject to explosion hazards

### Technical specifications

#### Zone 1 with type of protection Ex e II Increased Safety "e"

All 1MA motors are certified in type of protection Ex e II for temperature classes T1 to T3 at an ambient temperature from -20 to +40 °C and have an EU type test certificate according to Directive 94/9/EG (ATEX 95). Higher temperature classes are available on request.

Explosion protection is achieved when the certified motor versions interact with a similarly certified motor protection switch. The motor protection switch is selected in accordance with the values certified for the motor for the starting current ratio  $I_{LR}/I_{rated}$  and the  $t_E$  times, so that in the case of a locked rotor fault, the motor is isolated from the supply within the  $t_E$  time. The  $t_E$  times assigned to the separate temperature classes and the starting current ratio are marked on the rating plate.

Explosion protection can be achieved exclusively by the PTC thermistors embedded in the winding provided that the motor has been specially approved and certified for this. This type of protection is not technically possible for every motor, so it is essential to inquire before ordering.

With the exception of 2-pole motors of frame size 225 M and above, all motors are of an identical version, i.e. the motors can be operated at T1/T2 or T3 at the appropriate rated output. For special versions (different frequency, output, coolant temperature, site altitude, etc.) a new certificate is necessary (please inquire). The temperature class must be specified in the order, otherwise the universal version T1/T2 and T3 will be certified (doubling the certification costs).

Identification on the rating plate:

 II 2G Ex e II T1 – T3

#### Zone 1 with type of protection Ex de IIC explosion-proof enclosure "d"

All 1MJ motors are certified for the highest explosion group IIC, temperature classes T1 to T4 at ambient temperatures from -20 to +60 °C and have an EC type test certificate according to Directive 94/9/EG (ATEX 95).

These motors are designed such that an explosion within the housing cannot result in an explosion in the environment. The energy that is generated internally by an explosion is dissipated in the so-called "flameproof chamber" so far that the energy is no longer sufficient for ignition outside the casing. The housing temperature is below the ignition temperature of the gases to which temperature class T4 applies.



The 1MJ6 motors (frame sizes 71 to 200) generally have a located bearing on the non-drive-end (NDE) of the motor.

The following variations are possible on request:

- Coolant temperature >40 °C or site altitude >1000 m (for 1MJ6, the reduction factors listed in catalog part 0 "Introduction" under "General technical data", "Coolant temperature and site altitude" are applicable).
- Frequency and rated duty
- Pole-changing motors
- Insulated bearing at the non-drive-end (NDE)
- Use according to temperature class 155 (F) in mains-fed operation

On the frequency converter, motors in type of protection "explosion-proof enclosure" can be used thermally acc. to temperature class 155 (F). Converter-fed operation can be ordered with order code **A15** (PTC thermistors for tripping) or **A16** (PTC thermistors for alarm and tripping), whereby an additional PTC thermistor is fitted to 1MJ6/1MJ7 motors in the connection box.

Identification on the rating plate:

 II 2G Ex de IIC T1 – T4  
or  
 II 2G Ex d IIC T1 – T4

# IEC Squirrel-Cage Motors

## Explosion-proof motors

### Orientation

#### Technical specifications (continued)

##### Zone 2 with type of protection Ex nA (non-sparking)

- Zone 2 acc. to IEC/EN 60079-15  
The duty types are:
  - Design for Zone 2 for mains-fed operation (order code **M72**)
  - Design for Zone 2 for mains-fed operation, with derating (order code **M73**)

1LA/1LG motors are modified for this purpose in the "Non-sparking" design and are suitable for use in hazardous areas of Zone 2 for temperature classes T1 to T3. The maximum surface temperature that can occur during operation must lie below the limit temperature of the respective temperature class. The ventilation system must be in accordance with IEC/EN 60079-0. An external earthing terminal is fitted to the motors. The connection box is similar to the EExe design.

Please inquire in the case of

- Use in accordance with temperature class 155 (F)
- For pole-changing versions

For motors in the "Non-sparking" version, a conformity declaration is available from a recognized testing authority.

Ambient temperature  $-20$  to  $+60$  °C, whereby derating applies from  $40$  °C upwards. Other temperatures are available on request.

The rating plate or the extra rating plate contains the text:

 II 3G Ex nA II T3

IEC/EN 60079-15 and number of the "Conformity declaration"

The motors do not have a rated voltage range stamped on the rating plate.

##### Protection against dust explosions in Zones 21 and 22

The distinction between Zones 21 and 22 is as follows:

- Zone 21 according to IEC 61241, EN 50281<sup>1)</sup>
  - Design for Zone 21<sup>2)</sup>, as well as Zone 22 for conducting dust (IP65) for mains-fed operation (order code **M34**)
  - Design for Zone 21<sup>2)</sup>, as well as Zone 22 for conducting dust (IP65) for converter-fed operation, derating (order code **M38**)

- Zone 22 according to IEC 61241, EN 50281
  - Design for Zone 22 for non-conducting dust (IP55) for mains-fed operation (order code **M35**)
  - Design for Zone 22 for non-conducting dust (IP55) for converter-fed operation, derating (order code **M39**)

The 1LA/1LG motors are modified for this purpose for use in zones subject to dust explosion hazards. The surface temperature is  $\leq 125$  °C at rated duty.

An external earthing terminal and a metal external fan are fitted to the motors. In the design for Zone 21, the connection box is similar to the Exe design.

Pole-changing versions are not possible for Zone 21 – they are possible for Zone 22 on request.

Certification:

- Zone 21: EC type-test certificate (ATEX), issued by the DMT testing authority (Deutsche Montan-Technologie) and EC declaration of conformity.
- Zone 22: EC declaration of conformity

Identification on the rating plate:

Zone 21:  II 2D Ex tD A21 IP65 T125 °C

Zone 22:  II 3D Ex tD A22 IP55 T125 °C

Ambient temperature  $-20$  °C to  $+60$  °C, whereby derating applies from  $40$  °C upwards. Other temperatures are available on request.

##### Generally, the following is valid:

All Ex motors in vertical type of construction with shaft extension pointing down must have a protective cover.

Ex motors cannot be designed in accordance with UL and CSA.

The certificates for the motors for hazardous areas are stored with the documentation in the SD configurator tool for low-voltage motors.

For converter-fed operation, Ex motors must always be monitored using PTC thermistors. Certified tripping units are required for this purpose, see Catalog LV1.

Comprehensive operating instructions and the declaration of conformity are supplied with Ex motors.

In the case of non-standard 1LA8 and 1PQ8 motors, the bearing temperature must be monitored (order code **A72**).

#### Overview of the technical specifications

Explosion-proof motors - The technology at a glance

Motors	Type of protection "e"	Type of protection "d"	Type of protection "n"	Dust explosion protection
Frame size	63 M ... 315 L	71 M ... 315 M	63 M ... 450	56 M ... 450 L
Output range	0.12 to 160 kW	0.25 ... 132 kW	0.09 to 1000 kW	0.06 to 1000 kW
Number of poles	2/4/6	2/4/6/8	2/4/6/8	2/4/6/8
Temperature class	T1 - T3	T1 - T4	T3	-
Degree of protection	II 2 G Ex e II acc. to IEC/EN 60079-0 IEC/EN 60079-7	II 2 G Ex de II acc. to IEC/EN 60079-0 IEC/EN 60079-1	II 3 G Ex nA acc. to IEC/EN 60079-15	Zone 21: II 2D Ex td A21 IP65 T125 °C <sup>3)</sup> Zone 22: II 3D Ex td A22 IP55 T125 °C acc. to EN 50281/IEC 61241
Directive	94/9/EG, ATEX 95	94/9/EG, ATEX 95	94/9/EG, ATEX 95	94/9/EG, ATEX 95
Protection class	IP55	IP55	IP55	Zone 21: IP65 Zone 22: IP55
Voltages	All commonly used voltages	All commonly used voltages	All commonly used voltages	All commonly used voltages
Frequency	50 and 60 Hz	50 and 60 Hz	50 and 60 Hz	50 and 60 Hz
Type of construction	All common types of construction	All common types of construction	All common types of construction	All common types of construction
Housing	FS 63 M ... 160 L aluminum FS 100 L ... 315 L cast-iron	FS 71 M ... 315 M cast-iron	FS 63 M ... 160 L aluminum FS 100 L ... 450 cast-iron	FS 56 M ... 225 M aluminum FS 100 L ... 450 <sup>1)</sup> cast-iron
Cooling method	Surface-cooled	Surface-cooled	Surface-cooled	Surface-cooled
Temperature class	155 (F) used acc. to 130 (B)	155 (F) used acc. to 130 (B) <sup>4)</sup>	155 (F) used acc. to 130 (B)	155 (F) used acc. to 130 (B) <sup>5)</sup>
Insulation system	DURIGNIT IR 2000	DURIGNIT IR 2000, converter-compatible up to 500 V, 690 V on request	DURIGNIT IR 2000, converter-compatible up to 500 V, 690 V on request	DURIGNIT IR 2000, converter-compatible up to 500 V, 690 V on request

<sup>1)</sup> Zone 21 only up to frame size 315 L

<sup>2)</sup> Zone 21 takes into account conducting and non-conducting dust

<sup>3)</sup> Zone 21 for "Non-standard motors frame size 315 and above" only up to frame size 315 possible.

<sup>4)</sup> For converter-fed operation used 155 (F)

<sup>5)</sup> For "Non-standard motors frame size 315 and above" temperature class 155 (F) used according to 155 (F).



### Technical specifications (continued)

#### Coolant temperature and site altitude

Coolant temperature  $-40\text{ °C}$  to  $+40\text{ °C}$  for Ex motor

For all 1LA5, 1LA6, 1LA7, 1LA9 motors (with the exception of 1LA9 with increased output), 1LG4, 1LG6, 1MA6, 1MA7 frame sizes 56 to 315 with the respective types of protection Ex e, Ex nA or dust-Ex (Zone 21/22), the operating ambient temperature can optionally be expanded up to  $-40\text{ °C}$ . Technical measures are required for this purpose (e.g. metal external fan).  
Order **D19**

The order code **D19** is not possible in combination with order code **L03** "Vibration-proof version".

The mechanical limit speed of the 2-pole motors 1LA5/1LA9 in design for Zone 21/22 is reduced from frame size 180 as compared to the values in catalog part 5 "Motors operating with frequency converters":

Frame size	Motor type	2-pole	
		$n_{\max}$ rpm	$f_{\max}$ Hz
180	1LA5/1LA9	3300	55
200		3100	51
225		3000	50

With converter-fed operation and operation on 60 Hz supplies, particular attention has to be paid to the mechanical limit speeds – 60 Hz data are not stamped on the rating plate.  
Alternative: 1LG4/1LG6 motors in design for Zone 21/22.

#### Special technology

The "Special technology" comprises Ex-mountings on explosion-proof motors.

The field of application of explosion-proof motors is considerably expanded by mounting Ex rotary pulse encoders or Ex separately driven fans.

The use of a separately driven fan is recommended to increase motor utilization at low speeds and to limit noise generation at speeds significantly higher than the synchronous speed.

*Both of these results can only be achieved with converter-fed operation.*

For explosion-proof motor versions with Ex rotary pulse encoder or Ex separately driven fan, see tables below.

### The following explosion-proof motor versions are available with an Ex rotary pulse encoder:

Type of protection	Order No. + order code	Frame size	Order code of the Ex rotary pulse encoder
Ex nA	1LA6/7/9... + M73 1LG4/6... + M73	100 L ... 160 L 180 M ... 315 L	<b>H86:</b> Mounting of explosion-proof rotary pulse encoder – LL841 900 006 – for use in Zones 2, 21, 22.
Dust-Ex (Zone 21)	1LA6/7... + M38 1LA5... + M38 1LA9... + M38 1LG4/6... + M38	100 L ... 160 L 180 M ... 225 M 100 L ... 200 L 180 M ... 315 L	
Dust-Ex (Zone 22)	1LA6/7... + M39 1LA5... + M39 1LA9... + M39 1LG4/6... + M39	100 L ... 160 L 180 M ... 225 M 100 L ... 200 L 180 M ... 315 L	
Ex nA or dust-Ex (Zone 22)	1LA6/7/9... + M75 1LG4/6... + M75	100 L ... 160 L 180 M ... 315 L	
Ex de	1MJ6... + A15/A16 1MJ7... + A15/A16	90 L ... 200 L 225 M ... 315 M	<b>H87:</b> Mounting of explosion-proof rotary pulse encoder on motors Ex d/de in Zone 1. • Ex OG 9 DN 1024 I (BG 90L – 160L) • Ex HOG 161 DN 1024I (BG 180M – 315L)

### The following explosion-proof motor versions are available with an Ex separately driven fan:

Type of protection	Order No. + order code	Frame size	Order code of the Ex separately driven fan
Ex nA	1LG4/6 + M73	225 M ... 315 L	<b>M95:</b> "Mounting of explosion-proof separately driven fan Ex nA for use in Zone 2".
Dust-Ex (Zone 21)	1LG4/6 + M38	225 M ... 315 L	<b>M96:</b> "Mounting of explosion-proof separately driven fan II 2D for use in Zone 21".
Dust-Ex (Zone 22)	1LG4/6 + M39 1LA6/7 + M39 1LA5 + M39 1LA9 + M39	180 M ... 315 L 100 L ... 160 L 180 M ... 225 M 100 L ... 200 L	<b>M97:</b> "Mounting of explosion-proof separately driven fan II 3D for use in Zone 22".
Ex de	1MJ7 + A15/A16	225 M ... 315 M	<b>M98:</b> "Mounting of explosion-proof separately driven fan Ex de for use in Zone 1".

Note: Notwithstanding, Ex separately driven fans can also be used for mains-fed operation in special applications.

# IEC Squirrel-Cage Motors

## Explosion-proof motors

### Orientation

#### Technical specifications (continued)

##### Ex rotary pulse encoder

The rotary pulse encoder can only be mounted on a standard non-drive end (NDE), i.e. a second shaft extension or protective cover cannot be supplied. Therefore, the user must implement a suitable cover for vertical mounting positions to prevent small parts from falling into the fan cover (see also standard IEC//EN 60079-0).

Ex rotary pulse encoders do not have insulated bearings due to their construction (request required!).

The degree of protection of the rotary pulse encoder must be observed. The relevant data are stamped on the rating plate of the rotary pulse encoder.

When an Ex rotary pulse encoder is mounted, the length of the motor increases by  $\Delta l$ . For an explanation of the additional dimensions and weights, see "Dimensions and weights".

##### LL 841 900 006 rotary pulse encoder

With its rugged construction, this rotary pulse encoder is also suitable for difficult operating environments. It is resistant to shock and vibration.

The LL 841 900 006 rotary pulse encoder for use in Zones 2, 21, 22 can be supplied with the already mounted ADS diagnostic system for an early error detection in the encoder.

Order code **H86**

Manufacturer:

Leine und Linde (Germany) GmbH

Bahnhofstraße 36

73430 Aalen

Tel. +49 (0)73 61-78093-0

Fax +49 (0)73 61-78093-11

<http://www.leinelinde.com>

e-Mail: [info@leinelinde.se](mailto:info@leinelinde.se)

Technical data for LL 841 900 006 (HTL version)

Mounting of encoder for use below  $-20\text{ °C}$  and higher than  $+40\text{ °C}$  on request.

Supply voltage $U_B$	+9 V to +30 V
Current input without load	max. 80 mA
Admissible load current per output	40 mA
Pulses per revolution	1024
Outputs	6 short-circuit proof square-wave pulses A, A', B, B', 0, 0' High Current HTL Isolated switching output for ADS signal
Pulse offset between the two outputs	$90^\circ \pm 25^\circ \text{ el.}$
Output amplitude	$U_{\text{High}} > U_B - 4\text{ V}$ $U_{\text{Low}} < 2.5\text{ V}$
Mark space ratio	1:1 $\pm 10\%$
Edge steepness	50 V/ $\mu\text{s}$ (without load)
Maximum frequency	100 kHz for 350 m cable
Maximum speed	4200 rpm
Temperature range	$-40\text{ to }+70\text{ °C}$
Degree of protection	IP65
Max. adm. radial cantilever force	150 N
Max. adm. axial force	100 N
Termination system	Terminal strips in encoder, Cable connection M20 x 1.5 radial

##### Ex OG9 DN 1024 I rotary pulse encoder

The Ex OG9 DN 1024 I rotary pulse encoder for use on Ex d/de motors in Zone 1 (frame sizes 90 to 160) can be supplied already mounted.

Order code **H87**

Manufacturer:

Baumer Hübner GmbH

Planufer 92b

10967 Berlin

Tel. +49 (0)30-6 90 03-0

Fax +49 (0)30-6 90 03-1 04

<http://www.baumerhuebner.com>

e-Mail: [info@baumerhuebner.com](mailto:info@baumerhuebner.com)

Technical data for Ex OG9 DN 1024 I rotary pulse encoder (HTL version)

Mounting of encoder for use below  $-20\text{ °C}$  and higher than  $+40\text{ °C}$  on request.

Supply voltage $U_B$	+9 V to +30 V
Current input without load	Approx. 90 mA
Admissible load current per output	60 mA, 300 mA peak
Pulses per revolution	1024
Outputs	6 short-circuit proof square-wave pulses A, B and A', B' and R, R'
Pulse offset between the two outputs	$90^\circ \pm 20\%$
Output amplitude	$U_{\text{High}} \geq U_B - 3.5\text{ V}$ $U_{\text{Low}} \leq 1.5\text{ V}$
Mark space ratio	1:1 $\pm 20\%$
Edge steepness	10 V/ $\mu\text{s}$
Maximum frequency	120 kHz
Maximum speed	7000 rpm
Temperature range	$-20\text{ to }+55\text{ °C}$
Degree of protection	IP56
Max. adm. radial cantilever force	350 N
Max. adm. axial force	200 N
Termination system	Terminals with increased safety e, Cable connection M20 x 1.5
Mech. design acc. to Hübner Ident. No.	73 775 B
Weight	Approx. 3.5 kg

### Technical specifications (continued)

#### Ex HOG 161 DN 1024 I rotary pulse encoder

With its rugged construction, this rotary pulse encoder is also suitable for difficult operating environments.

The HOG10 DN 1024 I rotary pulse encoder for use on Ex d/de motors in Zone 1 (frame sizes 180 to 315) can be supplied already mounted.

Order code **H87**

Manufacturer:  
Baumer Hübner GmbH  
Planufer 92b  
10967 Berlin  
Tel. +49 (0)30-6 90 03-0  
Fax +49 (0)30-6 90 03-1 04

<http://www.baumerhuebner.com>  
e-Mail: [info@baumerhuebner.com](mailto:info@baumerhuebner.com)

Technical data for HOG10 DN 1024 I (HTL version)

Mounting of encoder for use below -20 °C and higher than +40 °C on request.

Supply voltage $U_B$	+9 V to +30 V
Current input without load	Approx. 100 mA
Admissible load current per output	60 mA, 300 mA peak
Pulses per revolution	1024
Outputs	64 short-circuit proof square-wave pulses A, B and A', B' and R, R'
Pulse offset between the two outputs	90° ±20 %
Output amplitude	$U_{High} = U_B - 3.5 V$ $U_{Low} = 1.5 V$
Mark space ratio	1:1 ±20 %
Edge steepness	10 V/μs
Maximum frequency	120 kHz
Maximum speed	5600 rpm
Temperature range	-20 to +65 °C
Degree of protection	IP56
Max. adm. radial cantilever force	650 N
Max. admissible axial force	450 N
Termination system	Terminals with increased safety e, Cable connection M20 x 1.5
Mech. design acc. to Hübner Ident. No.	74 140 A
Weight	Approx. 8.8 kg

### Dimensions and weights of the rotary pulse encoders

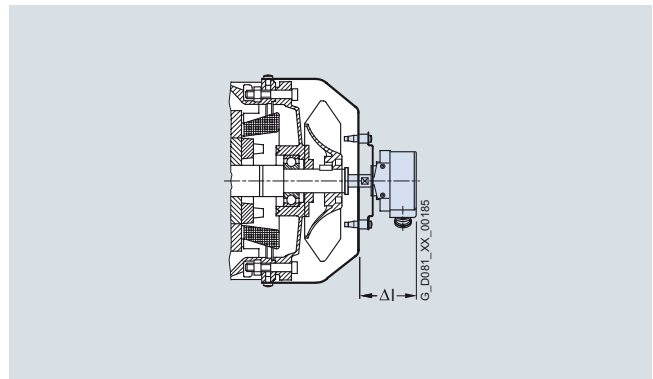

Ex rotary pulse encoder (on cover), order codes **H86, H87**

Frame size	Ex d/de (Zone 1)		Ex nA (Zone 2) and dust-Ex (Zone 21/22)			
	1MJ6/7	1LA5/6/7/9	1LG4/6	Weight approx.	Δl	Weight approx.
	mm	kg	mm	kg	mm	kg
90	184	14.0	–	–	–	–
100	188	14.5	110	2.0	–	–
112	190	14.5	110	2.0	–	–
132	186	16.5	110	2.0	–	–
160	183	17.5	110	2.0	–	–
180	164	9.0	110	2.0	100	3
200	164	9.0	110	2.0	100	3
225	160	12	110	2.0	100	3
250	160	12	–	–	100	3
280	160	12	–	–	100	3
315	160	12	–	–	100	3

The 1MJ6 motors of frame sizes 90 to 160 feature the rugged, flanged Ex OG9 rotary pulse encoder, which provides a high mechanical protection itself.

A protective cover of non-corrosive sheet steel is available for Ex rotary pulse encoders from the "Special technology" section, see "Mechanical protection for encoder" under "Mechanical design and degrees of protection".

Order code **M68**

Consequently, the motor length also increases:

- 1LA up to 146 mm
- 1MJ6 up to 175 mm
- 1LG/1MJ7 up to 25 mm

# IEC Squirrel-Cage Motors

## Explosion-proof motors

### Orientation

#### Technical specifications (continued)

##### Ex separately driven fan

The use of a separately driven fan is recommended to increase motor utilization at low speeds and to limit noise generation at speeds significantly higher than the synchronous speed. Both of these results can only be achieved with converter-fed operation. Please inquire about traction and vibratory operation.

The separately driven fan can be supplied already mounted for the following zones:

- Mounting of explosion-proof separately driven fan Ex de for use in Zone 1  
Order code **M98**
- Mounting of explosion-proof separately driven fan Ex nA for use in Zone 2  
Order code **M95**
- Mounting of explosion-proof separately driven fan II 2D for use in Zone 21  
Order code **M96**
- Mounting of explosion-proof separately driven fan II 3D for use in Zone 22  
Order code **M97**

The supply voltage of the Ex separately driven fan motors is defined as follows:

Type 2CW2 has voltage windings for wide range voltages (see subsequently "Technical data of separately driven fan for Ex motors 1LA5/6/7/9, 1LG4/6 (frame sizes 180 and 200) in design for Zone 22").

The separately driven fan motors 1LA/1MJ have a rated voltage (rated voltage range) with tolerances in accordance with EC/EN 60034-1, Categories A and B.

A rating plate with the operating data is applied to the Ex separately driven fan motors.

The type of protection of the Ex separately driven fan motor corresponds with the type of protection of the assigned Ex basic motor (note order codes for the appropriate zone).

Please note the direction of rotation of the separately driven fan (axial-flow fan) when connecting it.

Coolant temperatures deviating from  $-20$  to  $+40$  °C on request.

The Ex separately driven fan has degree of protection IP55 as standard (higher degrees of protection on request).

Motors with separately driven fans must use a PTC thermistor as motor protection. The Ex motor versions for converter-fed operation (order codes: M73, M38, M39, M75, M77, A15, A16) already have PTC thermistors for tripping. The PTC thermistor must safely shut down the motor if the separately driven fan is defective.

For selection information and order numbers, see the tables "Technical data of separately driven fan for Ex motors ..." on the following pages. A rating plate listing all the important data is fitted to the separately driven fan. For supply voltages outside the rated voltage range for 1LA motors, order code **Y81** and plain text required. Please note the direction of rotation of the separately driven fan (axial-flow fan) when connecting it. Admissible coolant temperatures are  $CT_{min}$   $-20$  °C or  $CT_{max}$   $+40$  °C. Lower coolant temperatures on request.

When the separately driven fan is mounted, the length of the motor increases by  $\Delta l$ . For an explanation of the additional dimensions and weights, see "Technology", "Dimensions and weights".

#### Technical data of separately driven fan for Ex motors 1LA5/6/7/9, 1LG4/6 (frame sizes 180 and 200) in design for Zone 22

Frame size	Designation on rating plate of separately driven fan	Rated voltage range		Frequency	Rated speed	Power consumption	Rated current
			V	Hz	rpm	kW	A
100	2CW2 180-8RF54-1AC0	1 AC	230 to 277	50	2790	0.075	0.29
		3 AC	220 to 290 $\Delta$	50	2830	0.086	0.27
		3 AC	380 to 500 Y	50	2830	0.086	0.16
		1 AC	230 to 277	60	3280	0.094	0.28
		3 AC	220 to 332 $\Delta$	60	3490	0.093	0.27
		3 AC	380 to 575 Y	60	3490	0.093	0.16
112	2CW2 180-8RF54-1AC1	1 AC	230 to 277	50	2720	0.073	0.26
		3 AC	220 to 290 $\Delta$	50	2770	0.085	0.27
		3 AC	380 to 500 Y	50	2770	0.085	0.15
		1 AC	230 to 277	60	3000	0.107	0.31
		3 AC	220 to 332 $\Delta$	60	3280	0.094	0.28
		3 AC	380 to 575 Y	60	3280	0.094	0.16
132	2CW2 180-8RF54-1AC2	1 AC	230 to 277	50	2860	0.115	0.40
		3 AC	220 to 290 $\Delta$	50	2880	0.138	0.45
		3 AC	380 to 500 Y	50	2880	0.138	0.24
		1 AC	230 to 277	60	3380	0.185	0.59
		3 AC	220 to 332 $\Delta$	60	3470	0.148	0.41
		3 AC	380 to 575 Y	60	3470	0.148	0.24
160 to 225 <sup>1)</sup>	2CW2 180-8RF54-1AC3	1 AC	230 to 277	50	2780	0.236	0.96
		3 AC	220 to 290 $\Delta$	50	2840	0.220	0.76
		3 AC	380 to 500 Y	50	2830	0.220	0.43
		3 AC	220 to 332 $\Delta$	60	3400	0.284	0.94
		3 AC	380 to 575 Y	60	3400	0.284	0.56

<sup>1)</sup> Separately driven fans with Order No. **1LA. ...** are used for 1LG motors of frame size 225 and above.

### Technical specifications (continued)

#### Technical data of separately driven fan for Ex motors 1LG4/6 (frame sizes 225 to 315) n design for Zones 2<sup>1)</sup>, 21, 22

Frame size	Designation on rating plate of separately driven fan	Rated voltage range		Frequency	Rated speed	Power consumption	Rated current at rated voltage <sup>2)</sup>
		V	Hz	rpm	kW	A	
225 M to 280 M	1LA7 073-2AA62-Z	3 AC	220 to 240 Δ	50	2800	0.550	1.36
		3 AC	380 to 420 Y	50	2800	0.550	0.79
		3 AC	440 to 480 Y	60	3400	0.630	1.32
315 – 2-pole	1LA9 073-2LA92-Z	3 AC	220 to 240 Δ	50	2780	0.700	1.73
		3 AC	380 to 420 Y	50	2780	0.700	1.00
		3 AC	440 to 480 Y	60	3385	0.700	1.64
315 – 4, 6, 8 -pole	1LA7 073-2AA62-Z	3 AC	220 to 240 Δ	50	2800	0.550	1.36
		3 AC	380 to 420 Y	50	2800	0.550	0.79
		3 AC	440 to 480 Y	60	3400	0.630	1.32

#### Technical data of separately driven fan for Ex motors 1MJ7 (frame sizes 225 bis 315) in design for Zone 1

Frame size	Designation on rating plate of separately driven fan	Rated voltage range		Frequency	Rated speed	Power consumption	Rated current at rated voltage
		V	Hz	rpm	kW	A	
225 M to 280 M	1MJ6 073-2CA92-Z: Data for 50/60 Hz	3 AC	220 to 240 Δ	50	2790	0.550	1.38
		3 AC	380 to 420 Y	50	2790	0.550	0.8
		3 AC	440 to 480 Y	60	3390	0.630	1.38
315 – 2-pole	1MJ6 073-2CA92-Z: Data for 50/60 Hz	3 AC	220 to 240 Δ	50	2790	0.550	1.38
		3 AC	380 to 420 Y	50	2790	0.550	0.8
		3 AC	440 to 480 Y	60	3390	0.630	1.38
315 – 4-, 6-, 8-pole	1MJ6 073-2CA92-Z: Data for 50/60 Hz	3 AC	220 to 240 Δ	50	2790	0.550	1.38
		3 AC	380 to 420 Y	50	2790	0.550	0.8
		3 AC	440 to 480 Y	60	3390	0.630	1.38

<sup>1)</sup> There is no rated voltage range for motors for Zone 2.

<sup>2)</sup> The values are only valid for the medium voltage of the rated voltage; therefore, there is no valid rated voltage range.

# IEC Squirrel-Cage Motors

## Explosion-proof motors

### Orientation

#### Technical specifications (continued)

#### Dimensions and weights of the Ex separately driven fans

Ex rotary pulse encoder (on cover) order codes **H86, H87**

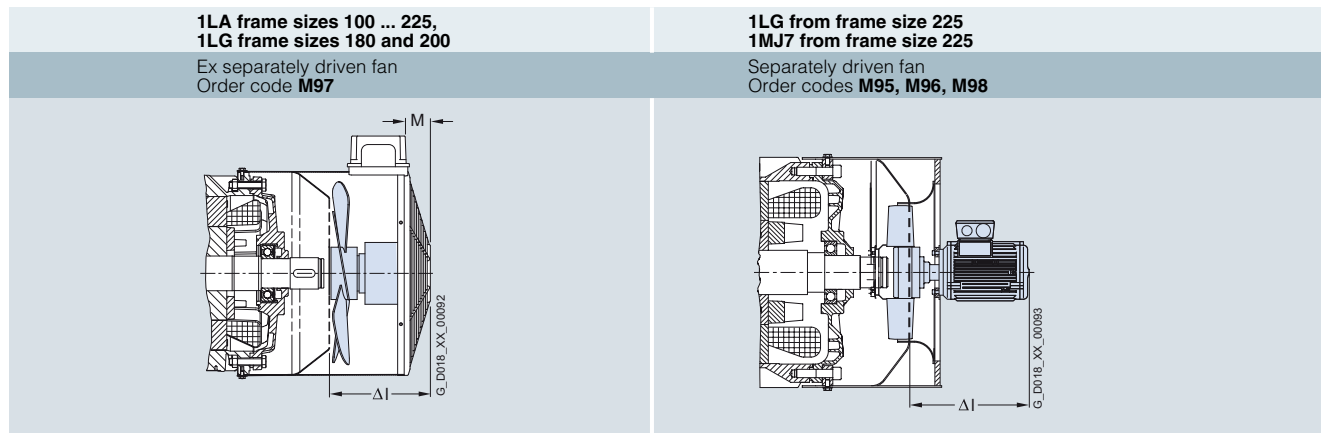

4

Frame size	Zone 22 1LA5/6/7/9		1LG4/6		Zones 2, 21 1LG4/6		Zone 1 (Ex d/de) 1MJ6/7	
	Δl	Weight approx. kg	Δl	Weight approx. kg	Δl	Weight approx. kg	Δl	Weight approx. kg
	mm		mm		mm		mm	
100	141	4	–	–	–	–	–	–
112	158	4.5	–	–	–	–	–	–
132	177	5.5	–	–	–	–	–	–
160	227	7	–	–	–	–	–	–
180	269	10	269	10	–	–	–	–
200	272	11	272	11	–	–	–	–
225	272	11	235	22	235	22	372	27
250	–	–	235	25	235	25	370	32
280	–	–	235	28	235	28	370	34
315	–	–	247	36	247	36	385	40

### Selection and ordering data

*Preliminary selection of the motor according to motor type/series, speed or number of poles, frame size, rated output, rated torque, rated speed and rated current*

Self-ventilated motors in Zone 1 with type of protection "e" (Ex e II Increased safety)

Speed	Frame size	Rated output	Rated speed	Rated torque	Rated current at 400 V	Detailed selection and ordering data Page
rpm		kW	rpm	Nm	A	
<b>Aluminum series 1MA7 50 Hz</b>						
<b>3000, 2-pole</b>	<b>63 M ... 160 L</b>	0.18 ... 16	2810 ... 2910	0.61 ... 53	0.55 ... 30.0	<b>4/18 ... 4/19</b>
<b>1500, 4-pole</b>	<b>63 M ... 160 L</b>	0.12 ... 13.5	1375 ... 1465	0.83 ... 88	0.52 ... 27	<b>4/20 ... 4/21</b>
<b>1000, 6-pole</b>	<b>71 M ... 160 L</b>	0.25 ... 9.7	850 ... 965	2.8 ... 96	0.81 ... 21	<b>4/20 ... 4/21</b>
<b>Cast-iron series 1MA6 50 Hz</b>						
<b>3000, 2-pole</b>	<b>100 L ... 315 L</b>	2.5 ... 165	2865 ... 2986	8.3 ... 528	5.3 ... 280	<b>4/22 ... 4/25</b>
<b>1500, 4-pole</b>	<b>100 L ... 315 L</b>	2 ... 165	1420 ... 1492	14 ... 1061	4.5 ... 305	<b>4/26 ... 4/29</b>
<b>1000, 6-pole</b>	<b>100 L ... 315 L</b>	1.3 ... 135	935 ... 991	13 ... 1300	3.35 ... 240	<b>4/30 ... 4/33</b>

Self-ventilated motors in Zone 1 with type of protection "de" (Ex de IIC explosion-proof enclosure)

Speed	Frame size	Rated output	Rated speed	Rated torque	Rated current at 400 V	Detailed selection and ordering data Page
rpm		kW	rpm	Nm	A	
<b>Cast-iron series 1MJ6 50 Hz</b>						
<b>3000, 2-pole</b>	<b>71 M ... 200 L</b>	0.37 ... 37	2750 ... 2945	1 ... 120	0.98 ... 64	<b>4/34 ... 4/35</b>
<b>1500, 4-pole</b>	<b>71 M ... 200 L</b>	0.25 ... 30	1325 ... 1465	1 ... 196	0.78 ... 55	<b>4/36 ... 4/37</b>
<b>1000, 6-pole</b>	<b>71 M ... 200 L</b>	0.25 ... 22	870 ... 975	2 ... 215	0.82 ... 42.5	<b>4/38 ... 4/39</b>
<b>750, 8-pole</b>	<b>90 L ... 200 L</b>	0.37 ... 15	655 ... 725	5 ... 198	1.16 ... 32	<b>4/40 ... 4/41</b>
<b>Cast-iron series 1MJ7 50 Hz</b>						
<b>3000, 2-pole</b>	<b>225 M ... 315 M</b>	45 ... 132	2955 ... 2980	145 ... 423	77 ... 225	<b>4/34 ... 4/35</b>
<b>1500, 4-pole</b>	<b>225 S ... 315 M</b>	37 ... 132	1475 ... 1486	240 ... 848	67 ... 232	<b>4/36 ... 4/37</b>
<b>1000, 6-pole</b>	<b>225 M ... 315 M</b>	30 ... 90	978 ... 988	293 ... 870	56 ... 162	<b>4/38 ... 4/39</b>
<b>750, 8-pole</b>	<b>225 S ... 315 M</b>	18.5 ... 75	725 ... 738	244 ... 970	37.5 ... 140	<b>4/40 ... 4/41</b>

# IEC Squirrel-Cage Motors

## Explosion-proof motors

### Orientation

#### Selection and ordering data (continued)

Self-ventilated motors in Zones 2, 21 and 22 with type of protection “n” or protection against dust explosions

Speed	Frame size	Rated output	Rated speed	Rated torque	Rated current at 400 V, 50 Hz at 460 V, 60 Hz	Detailed selection and ordering data Page
rpm		kW at 50 Hz HP at 60 Hz	rpm	Nm	A	
<b>Aluminum series 1LA7 and 1LA5<sup>1)</sup> 50 Hz</b>						
<b>3000, 2-pole</b>	<b>56 M<sup>2)</sup> ... 225 M</b>	0.09 ... 45	2830 ... 2959	0.3 ... 145	0.26 ... 78	<b>4/42 ... 4/43</b>
<b>1500, 4-pole</b>	<b>56 M<sup>2)</sup> ... 225 M</b>	0.06 ... 45	1350 ... 1470	0.42 ... 292	0.2 ... 80	<b>4/44 ... 4/45</b>
<b>1000, 6-pole</b>	<b>63 M ... 225 M</b>	0.09 ... 30	850 ... 978	1 ... 293	0.44 ... 61	<b>4/46 ... 4/47</b>
<b>750, 8-pole</b>	<b>71 M ... 225 M</b>	0.09 ... 22	630 ... 724	1.4 ... 290	0.36 ... 44.5	<b>4/48 ... 4/49</b>
<b>Aluminum series 1LA9</b>						
<b>“High Efficiency” 50 Hz</b>						
<b>3000, 2-pole</b>	<b>56 M ... 200 L</b>	0.09 ... 37	2830 ... 2950	0.3 ... 120	0.24 ... 64	<b>4/50 ... 4/51</b>
<b>1500, 4-pole</b>	<b>56 M ... 200 L</b>	0.06 ... 30	1380 ... 1465	0.42 ... 196	0.22 ... 53	<b>4/52 ... 4/53</b>
<b>1000, 6-pole</b>	<b>90 S ... 200 L</b>	0.75 ... 22	925 ... 975	7.7 ... 215	2 ... 45	<b>4/54 ... 4/55</b>
<b>For use in the North American market according to EPACT 60 Hz</b>						
<b>3600, 2-pole</b>	<b>56 M ... 200 L</b>	0.12 ... 50	3440 ... 3555	0.25 ... 100	0.23 ... 57	<b>4/56 ... 4/57</b>
<b>1800, 4-pole</b>	<b>56 M ... 200 L</b>	0.08 ... 40	1715 ... 1770	0.33 ... 161	0.18 ... 47	<b>4/58 ... 4/59</b>
<b>1200, 6-pole</b>	<b>90 S ... 200 L</b>	1 ... 30	1140 ... 1175	6.2 ... 182	1.78 ... 40	<b>4/60 ... 4/61</b>
<b>Cast-iron series 1LA6 and 1LG4 50 Hz</b>						
<b>3000, 2-pole</b>	<b>100 L ... 315 L</b>	3 ... 200	2890 ... 2982	9.9 ... 641	6.1 ... 325	<b>4/62 ... 4/63</b>
<b>1500, 4-pole</b>	<b>100 L ... 315 L</b>	2.2 ... 200	1420 ... 1486	15 ... 1285	4.7 ... 340	<b>4/64 ... 4/65</b>
<b>1000, 6-pole</b>	<b>100 L ... 315 L</b>	1.5 ... 160	925 ... 988	15 ... 1547	3.9 ... 285	<b>4/66 ... 4/67</b>
<b>750, 8-pole</b>	<b>100 L ... 315 L</b>	0.75 ... 132	679 ... 738	11 ... 1708	2.15 ... 245	<b>4/68 ... 4/69</b>
<b>Cast-iron series 1LG6</b>						
<b>“High Efficiency” 50 Hz</b>						
<b>3000, 2-pole</b>	<b>180 M ... 315 L</b>	22 ... 200	2955 ... 2982	71 ... 641	38.5 ... 320	<b>4/70 ... 4/71</b>
<b>1500, 4-pole</b>	<b>180 M ... 315 L</b>	18.5 ... 200	1470 ... 1490	120 ... 1282	34.5 ... 340	<b>4/70 ... 4/71</b>
<b>1000, 6-pole</b>	<b>180 M ... 315 L</b>	15 ... 160	975 ... 990	147 ... 1543	29.5 ... 280	<b>4/72 ... 4/73</b>
<b>750, 8-pole</b>	<b>180 M ... 315 L</b>	11 ... 132	725 ... 740	145 ... 1704	23.5 ... 240	<b>4/72 ... 4/73</b>
<b>For use in the North American market according to EPACT 60 Hz</b>						
<b>3600, 2-pole</b>	<b>180 M ... 315 L</b>	30 ... 300	3560 ... 3591	60 ... 595	34 ... 320	<b>4/74 ... 4/75</b>
<b>1800, 4-pole</b>	<b>180 M ... 315 L</b>	25 ... 300	1775 ... 1792	100 ... 1193	31 ... 335	<b>4/76 ... 4/77</b>
<b>1200, 6-pole</b>	<b>180 M ... 315 L</b>	20 ... 200	1178 ... 1192	121 ... 1195	25.5 ... 235	<b>4/78 ... 4/79</b>
<b>Cast-iron series 1LA8 50 Hz for mains-fed operation<sup>3)</sup></b>						
<b>3000, 2-pole</b>	<b>315 ... 450</b>	250 ... 1000	2979 ... 2986	801 ... 3200	415 ... 1020	<b>3/14 ... 3/15</b>
<b>1500, 4-pole</b>	<b>315 ... 450</b>	250 ... 1000	1488 ... 1492	1600 ... 6400	430 ... 1060	<b>3/14 ... 3/15</b>
<b>1000, 6-pole</b>	<b>315 ... 450</b>	200 ... 800	988 ... 993	1930 ... 7690	345 ... 1100	<b>3/16 ... 3/17</b>
<b>750, 8-pole</b>	<b>315 ... 450</b>	160 ... 630	739 ... 744	2070 ... 8090	295 ... 1160	<b>3/16 ... 3/17</b>
<b>Cast-iron series 1PQ8 50 Hz with standard insulation ≤500 V<sup>3)</sup></b>						
<b>3000, 2-pole</b>	<b>315 ... 450</b>	250 ... 1000	2979 ... 2986	801 ... 3200	415 ... 1020	<b>3/26 ... 3/27</b>
<b>1500, 4-pole</b>	<b>315 ... 450</b>	250 ... 1000	1488 ... 1492	1600 ... 6400	430 ... 1060	<b>3/26 ... 3/27</b>
<b>1000, 6-pole</b>	<b>315 ... 450</b>	200 ... 800	988 ... 993	1930 ... 7690	345 ... 1100	<b>3/28 ... 3/29</b>
<b>750, 8-pole</b>	<b>315 ... 450</b>	160 ... 630	739 ... 744	2070 ... 8090	295 ... 1160	<b>3/28 ... 3/29</b>

Motors for converter-fed operation 1LA8<sup>3)</sup> with normal and special insulation or 1PQ8<sup>3)</sup> with special insulation, see overview on Page 3/11.

<sup>1)</sup> Motor series 1LA5 is not possible for Zone 2.

<sup>2)</sup> Motor series 1LA7 is only possible for Zone 2 in frame size 63 M and above.

<sup>3)</sup> Motor series 1LA8 and 1PQ8 are not possible for Zone 21, 1PQ8 for Zones 2 and 22 on request.



### More information

#### Fundamental physical principles and definitions

##### Explosion

An explosion is the sudden chemical reaction of a combustible substance with oxygen, involving the release of high energy. Combustible substances can be gases, vapors, fumes or dust. An explosion can only take place if the following three factors coincide:

1. Combustible substance (in the relevant distribution and concentration)
2. Oxygen (in the air)
3. Source of ignition (e.g. electrical spark)

##### Primary and secondary explosion protection

#### Integrated explosion protection

1. Prevention of dangerous potentially explosive atmospheres
2. Prevention of the ignition of dangerous potentially explosive atmospheres
3. Limiting the explosion to a negligible degree

The principle of integrated explosion protection requires all explosion protection measures to be carried out in a defined order. A distinction is made here between primary and secondary protective measures.

Primary explosion protection covers all measures that prevent the formation of a potentially explosive atmosphere.

What are the protective measures that can be taken to minimize the risk of an explosion?

- Avoidance of combustible substances
- Inerting (addition of nitrogen, carbon dioxide, etc.)
- Limiting of the concentration
- Improved ventilation

*Secondary explosion protection is required if the explosion hazard cannot be removed or can only be partially removed using primary explosion protection measures.*

When considering safety-related factors, it is necessary to know certain characteristic quantities of combustible materials.

##### Flash point

The flash point for flammable liquids specifies the lowest temperature at which a vapor-air mixture forms over the surface of the liquid that can be ignited by a separate source.

If the flash point of such a flammable liquid is significantly above the maximum occurring temperatures, a potentially explosive atmosphere cannot form there. However, the flash point of a mixture of different liquids can also be lower than the flash point of the individual components.

In technical regulations, flammable liquids are divided into four hazard classes:

Hazard class	Flash point
AI	<21 °C
AII	21 ... 55 °C
AIII	>55 ... 100 °C
B	<21 °C, at 15 °C soluble in water

##### Explosion limits

Combustible substances form a potentially explosive atmosphere when they are present within a certain range of concentration (see "Area subject to explosion hazard").

If the concentration is too low (lean mixture) and if the concentration is too high (rich mixture) an explosion does not take place. Instead slow burning takes place, or no burning at all. Only in the area between the upper and the lower explosion limits does the mixture react explosively if ignited. The explosion limits depend on the surrounding pressure and the proportion of oxygen in the air (see the table below).

We refer to a deflagration, explosion, or detonation, depending on the speed of combustion. A potentially explosive atmosphere is present if ignition represents a hazard for personnel or materials. A potentially explosive atmosphere, even one of low volume, can result in hazardous explosions in an enclosed space.

##### Area subject to explosion hazard

100 % vol	Air concentration	0 % vol
Mixture too weak	Area subject to explosion hazard	Mixture too rich
No combustion		Partial combustion, no explosion
← Lower explosion limit upper →		
0 % vol		100 % vol
Concentration of combustible substance		

##### Dusts

In industrial environments, e.g. in chemical plants or in flour mills, solid matter is often present in small particles and also in the form of dust.

The term "dust" is defined in DIN EN 50281-1-2 as small solid particles in the atmosphere that are deposited due to their own weight but which remain in the atmosphere for some time in the form of a dust/air mixture". Dust deposits are comparable to a porous body and have an air component of up to 90 %. If the temperature of dust deposits is increased, this can result in self-ignition of the combustible substance in the form of dust.

When deposits of dust with a small particle size are disturbed, there is a risk of explosion. This risk increases as the particle size decreases, because the surface area of the hollow space increases. Dust explosions are often the result of disturbed glowing dust deposits that carry the initial spark within them.

Explosions of gas/air or vapor/air mixtures can also disturb dust, in which case the gas explosion can become a dust explosion.

# IEC Squirrel-Cage Motors

## Explosion-proof motors

### Orientation

#### More information (continued)

In coal mines, methane gas explosions often caused coal dust explosions which surpassed the gas explosions in their effects.

The risk of an explosion is prevented by using explosion-proof equipment in accordance with its protection capability. The identification of the equipment categories mirrors the effectiveness of the explosion protection and therefore its use in the corresponding areas subject to explosion hazard.

The potential risk of explosive dust atmospheres and the selection of appropriate protective measures are assessed on the basis of safety characteristics for the materials involved. Dusts are subdivided here in accordance with two of their material-specific characteristics:

- **Conductivity**  
Dusts that have a specific electrical resistance of up to  $10^3 \Omega\text{m}$  are classed as conductive.
- **Combustibility**  
Combustible dusts, however, are characterized by the fact that they can burn or glow in air and that they can form explosive mixtures at atmospheric pressure and at temperature from  $-20$  to  $+60$  °C in combination with air.

Examples of safety characteristics in the case of disturbed dust include the minimum ignition energy and the ignition temperature, whereas in the case of dust deposits, the glowing temperature is a characteristic feature.

#### Minimum ignition energy

The application of a certain amount of energy is required to ignite a potentially explosive atmosphere.

The minimum energy is taken to be the lowest possible converted energy, for example, the discharge of a capacitor, that will ignite the relevant flammable mixture.

The minimum energy lies between approximately  $10^{-5}$  J for hydrogen, and several Joules for certain dusts.

What can cause ignition?

- Hot surfaces
- Adiabatic compression
- Ultrasound
- Ionized radiation
- Open flames
- Chemical reaction
- Optical radiation
- Electromagnetic radiation
- Electrostatic discharge
- Sparks caused mechanically by friction or impact
- Electrical sparks and arcing
- Ionized radiation

#### Legislative basis and standards

##### Legislative basis of explosion protection

Globally, explosion protection is regulated by the legislatures of the individual countries. At the international level, the IEC is attempting to get closer to the aim of "a single global test and certificate" by introducing the IECEx Scheme.

##### EU directives

In the European Union, explosion protection is regulated by directives and laws.

Electrical equipment for use in potentially explosive atmospheres must therefore possess test certification or approval. The relevant systems and equipment are graded as systems requiring monitoring and must only use devices approved for this purpose. In addition, commissioning, modification, and regular safety inspections must only be accepted or carried out by approved institutions or societies. The EU directives are binding for all member states and form the legal framework.

#### Selection of important EU directives

Short designation	Full text	Directive no.	Valid as of:	End of transition period
EX Directive (ATEX 95)	Directive of the European Parliament and Council of March 23, 1994 on the harmonization of laws of the Member States concerning equipment and protective systems intended for use in potentially explosive atmospheres	94/9/EG	03/01/96	06/30/03
ATEX 137	Minimum regulations for improving the health protection and safety of employees that could be endangered by potentially explosive atmospheres	1999/92/EG	12/16/99	06/30/03

### More information (continued)

#### National laws and regulations

In general, the EU directives are European laws that must be incorporated by the individual member states unmodified by ratification. Directive 94/9/EU was adopted completely into the German explosion protection regulation ExVO. The underlying legislation for technical equipment is the Equipment Safety Law (GSG) to which ExVO is appended as a separate regulation (11th GSGV).

In contrast, ATEX 137 (Directive - 1999/92/EC) contains only "Minimum regulations for improving the health protection and safety of employees that could be endangered by potentially explosive atmospheres", so that each EU member state can pass its own regulations beyond the minimum requirements. In the German Federal Republic, the contents of the directive have been implemented in factory safety legislation. In order to simplify the legislation, the contents of several earlier regulations have been simultaneously integrated into the factory safety legislation ('BetrSichVO'). From the area of explosion protection, these are:

- The regulation concerning electrical installations in potentially explosive atmospheres (EllexV)
- The acetylene regulation
- The regulation concerning flammable liquids

These regulations became defunct when the factory safety legislation came into force on 01/01/2003.

#### Explosion protection guidelines (EX-RL) of the professional associations

In the "Guidelines for the prevention of hazards from potentially explosive atmospheres with listed examples" of the *German Chemicals Professional Association*, specific information is given on the hazards of potentially explosive atmospheres and measures for their prevention or limitation are listed. Of special use are the examples of individual potentially explosive process plants in the most diverse industrial sectors in which these measures are listed in detail. Valuable suggestions and risk evaluations are available for planners and operators of such plants or similar process plants. While the EX Directives have no legal status, they are nevertheless to be regarded as important recommendations that can also be called upon for support in deciding legal questions in the event of damage.

#### Standards

There are a host of technical standards worldwide for the area of explosion protection. The standards environment is subject to constant modification. This is the result of both adaptation to technical progress and increased safety demands in society. International efforts towards harmonization also contribute to the aim of achieving the most uniform global standards possible and the resulting removal of barriers to trade.

#### EU standards

The standards for explosion protection valid in the European Union are created on the basis of the EU Directives under the leadership of CENELEC (European Committee for Electrotechnical Standardization). CENELEC comprises the national committees of the member states. Since, in the meantime, standardization at international level gained greatly in importance through the dynamism of the IEC (International Electrotechnical Commission), CENELEC has decided only to pass standards in parallel with the IEC. In practice, this means European standards in the area of electrical/electronic systems will now be created or redefined almost exclusively on the basis of IEC standards as harmonized EN standards. For the area of explosion protection, these are mainly the standards of the EN 60079 series. The numbers of harmonized European standards are built up according to the following system:

IEC/EN	60079-0	:	1997	Meaning
				Year of issue
				Number of standard
				Harmonized European Standard

#### IEC

At the international level, the IEC (International Electrotechnical Commission) issues standards for explosion protection. The Technical Committee TC31 is responsible. Standards for explosion protection are found in the IEC 60079-x series (previously IEC 79-x). The x represents the numbers of the individual technical standards, e.g. IEC 60079-7 for intrinsic safety.

#### Classification of explosion-protected equipment

##### Identification

The identification of electrical equipment for areas protected against explosion hazards should include:

- The manufacturer who supplied the equipment
- A designation that identifies it
- The implementation range
  - In underground mines I
  - Other areas II
  - Gases and vapors – G -, dusts – D – or mines – M -,
- The categories that specify whether the device can be used for specific zones
- The type(s) of protection to which the equipment complies
- The testing authority that issued the test certificate, the standard or version of the standard to which the equipment complies – including the registration number of the certificate from the testing authority, and if necessary, the special conditions to be observed.
- The data that is normally required for an identical item of equipment in industrial design should also be provided.

#### Example for identification according to 94/9/EU

CE	0158	⊕ Ex	II 2D	IP65	T125 °C	Meaning
						Temperature range
						Enclosure protection class
						Ex protection zone
						Nominated authority for certification of the QA system in accordance with 94/9/EU
						Conformity mark

Equipment identification code	Meaning
<b>SAMPLE_COMPANY</b>	Manufacturer and type designation
<b>Type 07-5103-.../...</b>	
<b>Ex II 2D IP65 T 125 °C</b>	Acc. to EN 50281-1-1. Protection afforded by housing, IP65 protection class, Max. surface temperature +125 °C
<b>PTB</b>	Serial No. of test authority
<b>00</b>	ATEX generation
<b>ATEX</b>	Certified 2000
<b>1081</b>	Symbol of test authority

# IEC Squirrel-Cage Motors

## Explosion-proof motors

### Orientation

#### More information (continued)

##### Device groups/categories

Devices are classified into device groups:

- Device group I
  - in underground operations
  - in mines
  - as well as open-cast operations
- Device group II
  - Devices for use in the other areas

Each device group contains equipment that is in turn assigned to different categories (Directive 94/9/EC).

The category specifies the zone in which the equipment may be used.

##### Comparison of device groups and categories

Device group I (mining)		
Category	M1: Extremely high level of safety	M2: High level of safety
Sufficient safety	Through 2 protective measures/in the event of 2 faults	Must be switched off in the presence of an Ex atmosphere.

Device group II (other areas subject to explosion hazard)						
Category	1: Extremely high level of safety		2: High level of safety		3: Normal level of safety	
Sufficient safety	Through 2 protective measures/in the event of 2 faults		In the event of frequent device faults/in the event of one fault		In the case of fault-free operation	
Use	Zone 0	Zone 20	Zone 1	Zone 21	Zone 2	Zone 22
Atmosphere	G (gas)	D (dust)	G	D	G	D

##### Zones

Potentially explosive atmospheres are divided into zones. Division into zones depends on the chronological and geographical probability of the presence of a hazardous, potentially explosive atmosphere.

Information and specifications for zone subdivision can be found in EN/IEC 60079-10.

Equipment in areas where a constant explosion hazard exists (Zone 0/20) are subject to stricter requirements, and by contrast, equipment in less hazardous areas (Zone 1/21, Zone 2/22) is subject to less stringent requirements. In general, 95 % of systems are installed in Zone 1 and only 5 % of equipment is in Zone 0.

##### Subdivision of combustible dusts into different zones

Flammable gases, vapors, and mist		
Zone	Equipment category	Description
0	1G	Hazardous, potentially explosive atmosphere present <b>continuously</b> and <b>over extended periods</b> .
1	2G 1G	It is to be expected that a hazardous, potentially explosive atmosphere will only occur <b>occasionally</b> .
2	3G 2G 1G	It is to be expected that a hazardous, potentially explosive atmosphere will occur <b>only rarely</b> and then only <b>for a short period</b> .

Flammable dusts		
Zone	Equipment category	Description
20	1D	Areas where a potentially explosive atmosphere comprising dust-air mixtures is present <b>continuously, over extended periods</b> or <b>frequently</b> .
21	2D 1D	Areas where it is expected that a hazardous, potentially explosive atmosphere comprising dust-air mixtures will occur <b>occasionally</b> and <b>for short periods</b> .
22	3D 2D 1D	Areas in which it is not to be expected that a potentially explosive atmosphere will be caused by stirred-up dust. If this does occur, then in all probability only <b>rarely</b> and <b>for a short period</b> .



##### Types of protection

The protection types are design measures and electrical measures carried out on the equipment to achieve explosion protection in the areas subject to explosion hazard.

Protection types are secondary explosion protection measures. The scope of the secondary explosion protection measures depends on the probability of the occurrence of a hazardous, potentially explosive atmosphere.

Electrical equipment for areas subject to explosion hazard must comply with the general requirements of IEC/EN 60079-0 and the specific requirements for the relevant type of protection in which the equipment is listed.

The types of protection listed on the pages below are significant in accordance with IEC/EN 60079-0. All types of protection are based on different principles.

Types of protection for gases							Use in Zone		
Degree of protection	Coding	Schematic diagram	Basic principle	Standard	Examples	0	1	2	
General requirements			General requirements for the type and testing of electrical equipment intended for the Ex area	IEC/EN 60079-0					
Increased safety	e		Applies only to equipment, or its component parts, that normally does not create sparks or arcs, does not attain hazardous temperatures, and whose mains voltage does not exceed 1 kV	IEC/EN 60079-7	Squirrel-cage motors, terminals, connection boxes		•	•	
Flameproof enclosure	d		If an explosion occurs inside the enclosure, the housing will withstand the pressure and the explosion will not be propagated outside the enclosure	IEC/EN 60079-1	Squirrel-cage motors, switchgear, transformers		•	•	
Types of protection	n	Zone 2 Several protection types are included under this type	Slightly simplified application of the other Zone 2 protection types – "n" stands for "non-igniting"	EN 50021 <sup>1)</sup> IEC/EN 60079-15	Squirrel-cage motors, programmable controllers			•	

<sup>1)</sup> From 2007 IEC/EN 60079-15

### More information (continued)

Types of protection for dusts		Basic principle	Standard	Examples	Use in Zone		
Type of protection	Coding				20	21	22
Pressurized enclosure	pD	Penetration of a surrounding atmosphere into the housing of electrical equipment is prevented by retaining an ignition protection gas (air, inert gas or other suitable gas) internally at a higher pressure than the surrounding atmosphere.	EN 50281 IEC 61241	Equipment in which sparks, arcs or hot components occur during operation	•	•	•
Encapsulation	mD	Components that can ignite a potentially explosive atmosphere through sparks or heating are embedded in a potting compound such that the explosive atmosphere cannot ignite. This is achieved by completely covering the components with a potting compound that is resistant to physical (particularly electrical, thermal and mechanical) as well as chemical influences.	EN 50281 IEC 61241	Switchgear and control cabinets	•	•	•
Protection by housing	tD	The housing is so thick that ingress of combustible dust is not possible. The external surface temperature of the housing is limited.	EN 50281 IEC 61241	Measuring and monitoring equipment	•	•	•
Intrinsic safety	iaD, ibD	Current and voltage are limited so that intrinsic safety is guaranteed. Sparks or thermal effects cannot ignite a dust/air mixture.	EN 50281 IEC 61241	Sensors and actuators	•	•	•

### Temperature classes

The ignition temperature of flammable gases or a flammable liquid is the lowest temperature of a heated surface at which the gas/air or vapor/air mixture just ignites.

Thus the highest surface temperature of any equipment must always be less than the ignition temperature of the surrounding atmosphere.

Temperature classes T1 to T6 have been introduced for electrical equipment of Explosion group II. Equipment is assigned to each temperature class according to its maximum surface temperature.

Equipment that corresponds to a higher temperature class can also be used for applications with a lower temperature class.

Flammable gases and vapors are assigned to the relevant temperature class according to ignition temperature.

### Definition of the temperature classes

Temperature class	Maximum surface temperature of the equipment	Ignition temperatures of combustible substances
T1	450 °C	>450 °C
T2	300 °C	>300 °C
T3	200 °C	>200 °C
T4	135 °C	>135 °C
T5	100 °C	>100 °C
T6	85 °C	>85 °C

### Classification of gases and vapors into explosion groups and temperature classes

Explosion group	Temperature classes					
	T1	T2	T3	T4	T5	T6
I	Methane					
II A	Acetone Ethane Ethyl acetate Ammonia Benzene (pure) Acetic acid Carbon monoxide Carbon dioxide Methane Methanol Propane Toluene	Ethyl alcohol i-amyl acetate n-butane n-butyl alcohol	Petrol Diesel fuel Aviation gasoline Fuel oil n-hexane	Acetyl aldehyde Ethyl ether		
II B	Town gas (illuminating gas)	Ethylene				
II C	Hydrogen	Acetylene				Carbon disulfide

For further information, please contact your local Siemens contact – see “Siemens Contacts Worldwide” in the Appendix.

# IEC Squirrel-Cage Motors

## Explosion-proof motors

Self-ventilated, in Zone 1 with type of protection "e"  
Aluminum series 1MA7

### Selection and ordering data

Rated output at		Temperature class	Frame size	Operating values at rated output					Order No.	Price	Weight
50 Hz	60 Hz			Rated speed at 50 Hz	Rated torque at 50 Hz	Efficiency at 50 Hz	Power factor at 50 Hz	Rated current at 380 ... 420 V, 50 Hz			
$P_{rated}$ kW	$P_{rated}$ kW		FS	$n_{rated}$ rpm	$T_{rated}$ Nm	$\eta_{rated}$ %	$\cos\phi_{rated}$	$I_{rated}$ A	For Order No. supplements for voltage and type of construction, see table below	m kg	
<b>2-pole, 3000 rpm at 50 Hz, 3600 rpm at 60 Hz, temperature class 155 (F), IP55 degree of protection, temperature classes T1 to T3</b>											
0.18	0.18	T1,T2,T3	63 M	2810	0.61	66	0.74	0.55	<b>1MA7 060-2BAQQ</b>	3.9	
0.25	0.25	T1,T2,T3	63 M	2800	0.85	68	0.81	0.7	<b>1MA7 063-2BAQQ</b>	4.5	
0.37	0.37	T1,T2,T3	71 M	2825	1.3	73	0.8	0.93	<b>1MA7 070-2BAQQ</b>	5.4	
0.55	0.55	T1,T2,T3	71 M	2785	1.9	72	0.80	1.4	<b>1MA7 073-2BAQQ</b>	7	
0.75	0.75	T1,T2,T3	80 M	2845	2.5	73	0.85	1.81	<b>1MA7 080-2BAQQ</b>	8.6	
1.1	1.1	T1,T2,T3	80 M	2855	3.7	79	0.85	2.5	<b>1MA7 083-2BAQQ</b>	10.3	
1.3	1.3	T1,T2,T3	90 S	2850	4.4	78	0.88	2.9	<b>1MA7 090-2BAQQ</b>	13.3	
1.85	1.85	T1,T2,T3	90 L	2860	6.2	81	0.88	3.95	<b>1MA7 096-2BAQQ</b>	16.1	
2.5	2.5	T1,T2,T3	100 L	2865	8.3	82	0.87	5.3	<b>1MA7 106-2BAQQ</b>	21	
3.3	3.3	T1,T2,T3	112 M	2875	11	84	0.89	6.7	<b>1MA7 113-2BBQQ</b>	27	
4.6	4.6	T1,T2,T3	132 S	2920	15	83	0.9	9.2	<b>1MA7 130-2BBQQ</b>	38	
5.5	5.5	T3	132 S	2925	18	86	0.92	10.6	<b>1MA7 131-2BBQQ<sup>1)</sup></b>	44	
7.5	7.5	T3	160 M	2945	24	87.5	0.9	14.3	<b>1MA7 163-2BBQQ<sup>1)</sup></b>	67	
10	10	T3	160 M	2940	33	88.5	0.92	18.6	<b>1MA7 164-2BBQQ<sup>1)</sup></b>	72	
12.5	12.5	T3	160 L	2940	41	89	0.93	23	<b>1MA7 166-2BBQQ<sup>1)</sup></b>	82	

Rated output at		Temperature class	Frame size	Operating values at rated output					Order No.	Price	Weight
50 Hz	60 Hz			Rated speed at 50 Hz	Rated torque at 50 Hz	Efficiency at 50 Hz	Power factor at 50 Hz	Rated current at 380 ... 420 V, 50 Hz			
$P_{rated}$ kW	$P_{rated}$ kW		FS	$n_{rated}$ rpm	$T_{rated}$ Nm	$\eta_{rated}$ %	$\cos\phi_{rated}$	$I_{rated}$ A	For Order No. supplements for voltage and type of construction, see table below	m kg	
<b>2-pole, 3000 rpm at 50 Hz, 3600 rpm at 60 Hz, temperature class 155 (F), IP55 degree of protection, temperature classes T1 and T2, with double rating plate (T1/T2 and T3)</b>											
6.5	6.5	T1,T2	132 S	2900	21	85	0.93	12.5	<b>1MA7 131-2BBQQ<sup>1)</sup></b>	44	
9.5	9.5	T1,T2	160 M	2920	31	87	0.91	18.1	<b>1MA7 163-2BBQQ<sup>1)</sup></b>	67	
13	13	T1,T2	160 M	2910	43	87.5	0.92	24.5	<b>1MA7 164-2BBQQ<sup>1) 2)</sup></b>	72	
16	16	T1,T2	160 L	2910	53	87	0.93	30	<b>1MA7 166-2BBQQ<sup>1) 2)</sup></b>	82	

### Order No. supplements

Motor type	Penultimate position: Voltage code				Final position: Type of construction code							
	50 Hz	230 V $\Delta$ /400 VY	400 V $\Delta$ /690 VY	500 VY	500 V $\Delta$	Without flange	With flange		With standard flange		With special flange	
						IM B3/6/7/8, IM V6 <sup>3)</sup>	IM B5, IM V3 <sup>3)</sup>	IM V1 with protective cover <sup>3) 4)</sup>	IM B35	IM B14, <sup>3)</sup> IM V19 <sup>3)</sup>	IM B34	IM B14 IM V19 <sup>3)</sup>
	<b>1</b>	<b>6</b>	<b>3</b>	<b>5</b>	<b>0</b>	<b>1</b>	<b>4</b>	<b>6</b>	<b>2</b>	<b>7</b>	<b>3</b>	
<b>1MA7 06 . . . . QQ</b>	○	–	○	–	□	✓	✓	✓	✓	✓	✓	
<b>1MA7 07 . . . . QQ</b>	○	○	○	–	□	✓	✓	✓	✓	✓	✓	
<b>1MA7 08 . . . . QQ</b>	○	○	○	–	□	✓	✓	✓	✓	✓	✓	
<b>1MA7 09 . . . . QQ</b>	○	○	○	–	□	✓	✓	✓	✓	✓	✓	
<b>1MA7 10 . . . . QQ</b>	○	○	○	○	□	✓	✓	✓	✓	✓	✓	
<b>1MA7 11 . . . . QQ</b>	○	○	○	○	□	✓	✓	✓	✓	✓	✓	
<b>1MA7 13 . . . . QQ</b>	○	○	○	○	□	✓	✓	✓	✓	✓	✓	
<b>1MA7 16 . . . . QQ</b>	○	○	○	○	□	✓	✓	✓	✓	✓	✓	

- Standard version
- Without additional charge
- ✓ With additional charge
- Not possible

Order other voltages with voltage code **9** in the penultimate position and the corresponding order code (see "Special versions" in the "Selection and ordering data" under "Voltages").

Order other types of construction with type of construction code **9** in the final position and the corresponding order code (see "Special versions" in the "Selection and ordering data" under "Types of construction").

For footnotes, see Page 4/19.

# IEC Squirrel-Cage Motors

## Explosion-proof motors

Self-ventilated, in Zone 1 with type of protection "e"  
Aluminum series 1MA7

### Selection and ordering data (continued)

Order No.	Locked-rotor torque	Locked-rotor current	Breakdown torque	Torque class	Moment of inertia	Noise at rated output		$t_E$ time	
	with direct starting torque	as multiple of rated current	torque	CL		Measuring surface sound pressure level at 50 Hz	Sound pressure level at 50 Hz	for temperature class T1/T2	for temperature class T3
	$T_{LR}/T_{rated}$	$I_{LR}/I_{rated}$	$T_B/T_{rated}$		$J$ kgm <sup>2</sup>	$L_{p(A)}$ dB(A)	$L_{WA}$ dB(A)	$t_E$ s	$t_E$ s
<b>2-pole, 3000 rpm at 50 Hz, 3600 rpm at 60 Hz, temperature class 155 (F), IP55 degree of protection, temperature classes T1 to T3</b>									
<b>1MA7 060-2BAQQ</b>	2.3	4.4	2.3	16	0.00018	49	60	30	27
<b>1MA7 063-2BAQQ</b>	2.2	4.4	2.3	16	0.00023	49	60	19	16
<b>1MA7 070-2BAQQ</b>	2.3	5.6	2.1	16	0.00035	52	63	28	25
<b>1MA7 073-2BAQQ</b>	3	5.2	2.6	16	0.00045	52	63	18	13
<b>1MA7 080-2BAQQ</b>	2.5	6.2	2.7	16	0.00085	56	67	13	11
<b>1MA7 083-2BAQQ</b>	2.8	6.4	3	16	0.0011	56	67	12	10
<b>1MA7 090-2BAQQ</b>	2.6	6.2	2.8	16	0.0015	60	72	12	11
<b>1MA7 096-2BAQQ</b>	2.8	7.2	2.8	16	0.002	60	72	9	8
<b>1MA7 106-2BAQQ</b>	2.6	7.4	2.8	16	0.0038	62	74	9	8
<b>1MA7 113-2BBQQ</b>	2.1	6.6	2.3	13	0.0055	63	75	10	9
<b>1MA7 130-2BBQQ</b>	1.9	6.8	2.5	13	0.016	68	80	15	13
<b>1MA7 131-2BBQQ</b>	2.2	7.7	2.7	13	0.021	68	80	15	13
<b>1MA7 163-2BBQQ</b>	2.2	7.6	3.1	13	0.034	70	82	29	18
<b>1MA7 164-2BBQQ</b>	2.1	7.6	2.9	13	0.04	70	82	23	12
<b>1MA7 166-2BBQQ</b>	2.3	7.6	3	13	0.052	70	82	21	9

Order No.	Locked-rotor torque	Locked-rotor current	Breakdown torque	Torque class	Moment of inertia	Noise at rated output		$t_E$ time for temperature class T1/T2	$t_E$ time for temperature class T3
	with direct starting torque	as multiple of rated current	torque	CL		Measuring surface sound pressure level at 50 Hz	Sound pressure level at 50 Hz	$t_E$ s	$t_E$ s
	$T_{LR}/T_{rated}$	$I_{LR}/I_{rated}$	$T_B/T_{rated}$		$J$ kgm <sup>2</sup>	$L_{p(A)}$ dB(A)	$L_{WA}$ dB(A)	$t_E$ s	$t_E$ s
<b>2-pole, 3000 rpm at 50 Hz, 3600 rpm at 60 Hz, temperature class 155 (F), IP55 degree of protection, temperature classes T1 and T2, with double rating plate (T1/T2 and T3)</b>									
<b>1MA7 131-2BBQQ</b>	1.9	6.5	2.3	13	0.021	68	80	12	7
<b>1MA7 163-2BBQQ</b>	1.7	6	2.4	13	0.034	70	82	24	–
<b>1MA7 164-2BBQQ</b>	1.6	5.8	2.2	13	0.04	70	82	16	–
<b>1MA7 166-2BBQQ</b>	1.8	5.8	2.3	13	0.052	70	82	15	–

- 1) For the following versions T3-output is stamped as standard:  
– order code **A11/A12**  
– voltage code "9"  
Alternative: order code **C30** "T1/T2-output on the rating plate"
- 2) Utilization according to temperature class 155 (F).

- 3) The following applies for explosion-proof motors: In the case of the types of construction with shaft extension down, the version "with protective cover" is required. For types of construction with shaft extension pointing upwards, a suitable cover must be implemented to prevent small parts from falling into the fan cover (see the standard IEC/EN 60079-0). The cover must not block the cooling air-flow.
- 4) The "Second shaft extension" option, order code **K16** is not possible.

# IEC Squirrel-Cage Motors

## Explosion-proof motors

Self-ventilated, in Zone 1 with type of protection "e"  
Aluminum series 1MA7

### Selection and ordering data (continued)

Rated output at		Temperature class	Frame size	Operating values at rated output					Rated current at 380 ... 420 V, 50 Hz	Order No.	Price	Weight
50 Hz	60 Hz			Rated speed at 50 Hz	Rated torque at 50 Hz	Efficiency at 50 Hz	Power factor at 50 Hz	Rated current at 380 ... 420 V, 50 Hz				
$P_{rated}$ kW	$P_{rated}$ kW		FS	$n_{rated}$ rpm	$T_{rated}$ Nm	$\eta_{rated}$ %	$\cos\phi_{rated}$	$I_{rated}$ A	For Order No. supplements for voltage and type of construction, see table below		IM B3 type of construction approx. $m$ kg	
<b>4-pole, 1500 rpm at 50 Hz, 1800 rpm at 60 Hz, temperature class 155 (F), IP55 degree of protection, temperature classes T1 to T3</b>												
0.12	0.12	T1,T2,T3	63 M	1375	0.83	55	0.66	0.52	<b>1MA7 060-4BBQQ</b>		3.9	
0.18	0.18	T1,T2,T3	63 M	1330	1.3	57	0.75	0.62	<b>1MA7 063-4BBQQ</b>		4.5	
0.25	0.25	T1,T2,T3	71 M	1310	1.8	60	0.77	0.8	<b>1MA7 070-4BBQQ</b>		6	
0.37	0.37	T3	71 M	1355	2.6	67	0.74	1.1	<b>1MA7 073-4BBQQ</b>		6.4	
0.55	0.55	T1,T2,T3	80 M	1390	3.8	73	0.73	1.59	<b>1MA7 080-4BAQQ</b>		8.4	
0.75	0.75	T1,T2,T3	80 M	1395	5.1	73	0.75	2.05	<b>1MA7 083-4BAQQ</b>		11	
1	1	T1,T2,T3	90 S	1420	6.7	77	0.78	2.5	<b>1MA7 090-4BAQQ</b>		12.7	
1.35	1.35	T1,T2,T3	90 L	1415	9.1	78	0.82	3.1	<b>1MA7 096-4BAQQ</b>		16	
2	2	T1,T2,T3	100 L	1420	14	80	0.82	4.5	<b>1MA7 106-4BAQQ</b>		20	
2.5	2.5	T1,T2,T3	100 L	1415	17	81	0.83	5.5	<b>1MA7 107-4BAQQ</b>		23	
3.6	3.6	T1,T2,T3	112 M	1435	24	85	0.83	7.5	<b>1MA7 113-4BAQQ</b>		29	
5	5	T1,T2,T3	132 S	1445	33	86	0.82	10.4	<b>1MA7 130-4BAQQ</b>		42	
6.8	6.8	T1,T2,T3	132 M	1465	44	87	0.82	14	<b>1MA7 133-4BAQQ</b>		61	
10	10	T1,T2,T3	160 M	1455	66	88	0.87	19.7	<b>1MA7 163-4BBQQ</b>		67	
13.5	13.5	T1,T2,T3	160 L	1465	88	89	0.84	27	<b>1MA7 166-4BBQQ</b>		107	
<b>6-pole, 1000 rpm at 50 Hz, 1200 rpm at 60 Hz, temperature class 155 (F), IP55 degree of protection, temperature classes T1 to T3</b>												
0.25	0.25	T1,T2,T3	71 M	850	2.8	63	0.72	0.81	<b>1MA7 073-6BAQQ</b>		6.7	
0.37	0.37	T1,T2,T3	80 M	920	3.6	68	0.7	1.14	<b>1MA7 080-6BAQQ</b>		8.3	
0.55	0.55	T1,T2,T3	80 M	930	5.6	69	0.67	1.75	<b>1MA7 083-6BAQQ</b>		12.5	
0.65	0.65	T1,T2,T3	90 S	915	6.8	70	0.75	1.8	<b>1MA7 090-6BAQQ</b>		14	
0.95	0.95	T1,T2,T3	90 L	915	9.9	72	0.75	2.6	<b>1MA7 096-6BAQQ</b>		15.7	
1.3	1.3	T1,T2,T3	100 L	935	13	77	0.73	3.35	<b>1MA7 106-6BAQQ</b>		20	
1.9	1.9	T1,T2,T3	112 M	940	19	79	0.76	4.7	<b>1MA7 113-6BBQQ</b>		24	
2.6	2.6	T1,T2,T3	132 S	945	26	79	0.75	6.5	<b>1MA7 130-6BBQQ</b>		36	
3.5	3.5	T1,T2,T3	132 M	955	35	81	0.72	9	<b>1MA7 133-6BBQQ</b>		41	
4.8	4.8	T1,T2,T3	132 M	950	48	83	0.76	11.4	<b>1MA7 134-6BBQQ</b>		50	
6.6	6.6	T1,T2,T3	160 M	960	65	85	0.75	14.9	<b>1MA7 163-6BBQQ</b>		70	
9.7	9.7	T1,T2,T3	160 L	965	96	88	0.76	21	<b>1MA7 166-6BBQQ</b>		105	

### Order No. supplements

Motor type	Penultimate position: Voltage code				Final position: Type of construction code						
	50 Hz				Without flange	With flange		With standard flange		With special flange	
	230 VΔ/400 VY	400 VΔ/690 VY	500 VY	500 VΔ	IM B3/6/7/8, IM V6 <sup>1)</sup>	IM B5, IM V3 <sup>1)</sup>	IM V1 with protective cover <sup>1) 2)</sup>	IM B35	IM B14, IM V19 <sup>1)</sup>	IM B34	IM B14 IM V19 <sup>1)</sup>
	1	6	3	5	0	1	4	6	2	7	3
<b>1MA7 06 . . . . □□</b>	○	–	○ <sup>3)</sup>	–	□	✓	✓	✓	✓	✓	✓
<b>1MA7 07 . . . . □□</b>	○	○	○	–	□	✓	✓	✓	✓	✓	✓
<b>1MA7 08 . . . . □□</b>	○	○	○	–	□	✓	✓	✓	✓	✓	✓
<b>1MA7 09 . . . . □□</b>	○	○	○	–	□	✓	✓	✓	✓	✓	✓
<b>1MA7 10 . . . . □□</b>	○	○	○	○	□	✓	✓	✓	✓	✓	✓
<b>1MA7 11 . . . . □□</b>	○	○	○	○	□	✓	✓	✓	✓	✓	✓
<b>1MA7 13 . . . . □□</b>	○	○	○	○	□	✓	✓	✓	✓	✓	✓
<b>1MA7 16 . . . . □□</b>	○	○	○	○	□	✓	✓	✓	✓	✓	✓

- Standard version
- Without additional charge
- ✓ With additional charge
- Not possible

Order other voltages with voltage code **9** in the penultimate position and the corresponding order code (see "Special versions" in the "Selection and ordering data" under "Voltages").

Order other types of construction with type of construction code **9** in the final position and the corresponding order code (see "Special versions" in the "Selection and ordering data" under "Types of construction").

For footnotes, see Page 4/21.



# IEC Squirrel-Cage Motors

## Explosion-proof motors

Self-ventilated, in Zone 1 with type of protection "e"  
Aluminum series 1MA7

### Selection and ordering data (continued)

Order No.	Locked-rotor torque	Locked-rotor current	Breakdown torque	Torque class	Moment of inertia	Noise at rated output		$t_E$ time	
	with direct starting torque	as multiple of rated current	torque			Measuring surface sound pressure level at 50 Hz	Sound pressure level at 50 Hz	for temperature class T1/T2	for temperature class T3
	$T_{LR}/T_{rated}$	$I_{LR}/I_{rated}$	$T_B/T_{rated}$	CL	$J$ kgm <sup>2</sup>	$L_{pFA}$ dB(A)	$L_{WA}$ dB(A)	$t_E$ s	$t_E$ s
<b>4-pole, 1500 rpm at 50 Hz, 1800 rpm at 60 Hz, temperature class 155 (F), IP55 degree of protection, temperature classes T1 to T3</b>									
1MA7 060-4BBQQ	1.9	2.6	1.9	13	0.0003	42	53	35	30
1MA7 063-4BBQQ	1.9	2.7	1.9	13	0.0004	42	53	30	25
1MA7 070-4BBQQ	1.9	3.1	1.9	13	0.0006	44	55	50	40
1MA7 073-4BBQQ	1.9	3.7	2.1	13	0.00083	44	55	35	29
1MA7 080-4BAQQ	2.4	4.6	2.5	16	0.0015	47	58	24	21
1MA7 083-4BAQQ	2.6	4.8	2.6	16	0.0018	47	58	19	16
1MA7 090-4BAQQ	2.2	5.4	2.5	16	0.0028	48	60	16	14
1MA7 096-4BAQQ	2.3	5.9	2.5	16	0.0035	48	60	15	13
1MA7 106-4BAQQ	2.5	6.4	2.7	16	0.0048	53	65	13	11
1MA7 107-4BAQQ	2.6	6.4	2.7	16	0.0058	53	65	12	10
1MA7 113-4BAQQ	2.6	7.2	2.9	16	0.011	53	65	10	9
1MA7 130-4BAQQ	2.7	6.6	3.2	16	0.021	62	74	10	9
1MA7 133-4BAQQ	3	7.7	3.6	16	0.027	62	74	11	9
1MA7 163-4BBQQ	2.3	6.5	2.7	13	0.052	66	78	17	10
1MA7 166-4BBQQ	2.4	6.9	3	13	0.057	66	78	18	9
<b>6-pole, 1000 rpm at 50 Hz, 1200 rpm at 60 Hz, temperature class 155 (F), IP55 degree of protection, temperature classes T1 to T3</b>									
1MA7 073-6BAQQ	2.2	3	2.1	16	0.0009	39	50	130	70
1MA7 080-6BAQQ	2.3	3.6	2.4	16	0.0015	40	51	60	55
1MA7 083-6BAQQ	2.4	4	2.4	16	0.0025	40	51	30	27
1MA7 090-6BAQQ	2.3	3.9	2.4	16	0.0028	43	55	35	30
1MA7 096-6BAQQ	2.3	4.1	2.4	16	0.0038	43	55	22	19
1MA7 106-6BAQQ	2.4	4.8	2.5	16	0.0063	47	59	26	26
1MA7 113-6BBQQ	2.3	5	2.5	13	0.011	52	64	19	16
1MA7 130-6BBQQ	1.8	4.4	2.4	13	0.015	63	75	21	18
1MA7 133-6BBQQ	2.3	5.1	2.8	13	0.019	63	75	16	13
1MA7 134-6BBQQ	2.4	5.6	2.8	13	0.025	63	75	13	11
1MA7 163-6BBQQ	2.7	6.4	3.1	13	0.041	66	78	18	9
1MA7 166-6BBQQ	2.8	7.7	2.2	13	0.055	66	78	15	8

4

- 1) The following applies for explosion-proof motors: In the case of the types of construction with shaft extension down, the version "with protective cover" is required. For types of construction with shaft extension pointing upwards, a suitable cover must be implemented to prevent small parts from falling into the fan cover (see the standard IEC/EN 60079-0). The cover must not block the cooling air-flow.
- 2) The "Second shaft extension" option, order code **K16** is not possible.
- 3) For motors 1MA7 06.-4. (motor series 1MA7 frame size 63, 4-pole) not possible.

# IEC Squirrel-Cage Motors

## Explosion-proof motors

Self-ventilated, in Zone 1 with type of protection "e"  
Cast-iron series 1MA6

### Selection and ordering data

Rated output at		Temperature class	Frame size	Operating values at rated output					Rated current at 380 ... 420 V, 50 Hz	Order No. For Order No. supplements for voltage and type of construction, see table below	Price	Weight IM B3 type of construction approx. <i>m</i> kg
50 Hz	60 Hz			Rated speed at 50 Hz	Rated torque at 50 Hz	Efficiency at 50 Hz	Power factor at 50 Hz	Rated current at 380 ... 420 V, 50 Hz				
$P_{rated}$ kW	$P_{rated}$ kW		FS	$n_{rated}$ rpm	$T_{rated}$ Nm	$\eta_{rated}$ %	$\cos\phi_{rated}$	$I_{rated}$ A				
<b>2-pole, 3000 rpm at 50 Hz, 3600 rpm at 60 Hz, temperature class 155 (F), IP55 degree of protection, temperature classes T1 to T3</b>												
2.5	2.5	T1,T2,T3	100 L	2865	8.3	82	0.87	5.3	<b>1MA6 106-2BAQQ</b>		34	
3.3	3.3	T1,T2,T3	112 M	2875	11	84	0.89	6.7	<b>1MA6 113-2BBQQ</b>		43	
4.6	4.6	T1,T2,T3	132 S	2920	15	83	0.9	9.3	<b>1MA6 130-2BBQQ</b>		53	
5.5	5.5	T3	132 S	2925	18	86	0.92	10.7	<b>1MA6 131-2BBQQ</b> <sup>1)</sup>		58	
7.5	7.5	T3	160 M	2945	24	87.5	0.9	15.3	<b>1MA6 163-2BBQQ</b> <sup>1)</sup>		96	
10	10	T3	160 M	2940	33	88.5	0.92	19.1	<b>1MA6 164-2BBQQ</b> <sup>1)</sup>		105	
12.5	12.5	T3	160 L	2940	41	89	0.93	23	<b>1MA6 166-2BBQQ</b> <sup>1)</sup>		115	
15	15	T3	180 M	2955	49	92	0.87	29	<b>1MA6 183-2BCQQ</b>		170	
20	20	T3	200 L	2950	64	91.2	0.87	49	<b>1MA6 206-2BCQQ</b>		245	
24	24	T3	200 L	2965	77	92	0.87	46	<b>1MA6 207-2BCQQ</b>		246	
28	28	T3	225 M	2970	90	93.6	0.9	51	<b>1MA6 223-2BCQQ</b>		310	
38	38	T1,T2	225 M	2970	122	93.9	0.89	69 <sup>2)</sup>	<b>1MA6 223-2ACQQ</b>		310	
36	36	T3	250 M	2975	116	93.5	0.91	64	<b>1MA6 253-2BCQQ</b>		415	
47	47	T1,T2	250 M	2975	151	93.9	0.9	85	<b>1MA6 253-2ACQQ</b>		415	
47	47	T3	280 S	2983	150	94.5	0.9	84	<b>1MA6 280-2BDQQ</b>		570	
64	64	T1,T2	280 S	2980	205	94.3	0.89	115	<b>1MA6 280-2ADQQ</b>		570	
58	58	T3	280 M	2982	186	94.7	0.91	104	<b>1MA6 283-2BDQQ</b>		610	
76	76	T1,T2	280 M	2978	244	94.8	0.9	134	<b>1MA6 283-2ADQQ</b>		610	
68	68	T3	315 S	2985	218	94	0.91	120	<b>1MA6 310-2BDQQ</b>		790	
95	95	T1,T2	315 S	2985	304	94.6	0.9	169	<b>1MA6 310-2ADQQ</b>		790	
80	80	T3	315 M	2985	256	94.8	0.91	142	<b>1MA6 313-2BDQQ</b>		850	
112	112	T1,T2	315 M	2985	358	94.8	0.91	198 <sup>2)</sup>	<b>1MA6 313-2ADQQ</b>		850	
100	100	T3	315 L	2984	320	94.9	0.92	174	<b>1MA6 316-2BDQQ</b>		990	
135	135	T1,T2	315 L	2984	432	95.2	0.91	234	<b>1MA6 316-2ADQQ</b>		990	
125	125	T3	315 L	2985	400	95.5	0.91	214	<b>1MA6 317-2BDQQ</b> <sup>3)</sup>		1100	
165	165	T1,T2	315 L	2986	528	95.7	0.91	280	<b>1MA6 317-2ADQQ</b> <sup>3)</sup>		1100	

### Order No. supplements

Motor type	Penultimate position: Voltage code				Final position: Type of construction code						
	50 Hz				Without flange	With flange		With standard flange			With special flange
	230 VΔ/400 VY	400 VΔ/690 VY	500 VY	500 VΔ	IM B3/6/7/8, IM V6 <sup>4)5)</sup>	IM B5, IM V3 <sup>4)6)</sup>	IM V1 with protective cover <sup>4)6)7)</sup>	IM B35	IM B14, IM V19 <sup>4)</sup>	IM B34	IM B14 IM V19 <sup>4)</sup>
	<b>1</b>	<b>6</b>	<b>3</b>	<b>5</b>	<b>0</b>	<b>1</b>	<b>4</b>	<b>6</b>	<b>2</b>	<b>7</b>	<b>3</b>
<b>1MA6 10</b> . . . . . <b>QQ</b>	○	○	○	○	□	✓	✓	✓	✓	✓	✓
<b>1MA6 11</b> . . . . . <b>QQ</b>	○	○	○	○	□	✓	✓	✓	✓	✓	✓
<b>1MA6 13</b> . . . . . <b>QQ</b>	○	○	○	○	□	✓	✓	✓	✓	✓	✓
<b>1MA6 16</b> . . . . . <b>QQ</b>	○	○	○	○	□	✓	✓	✓	✓	✓	✓
<b>1MA6 18</b> . . . . . <b>QQ</b>	○	○	○	○	□	✓ <sup>8)</sup>	✓	✓	–	–	–
<b>1MA6 20</b> . . . . . <b>QQ</b>	○	○	○	○	□	✓ <sup>8)</sup>	✓	✓	–	–	–
<b>1MA6 22</b> . . . . . <b>QQ</b>	○	○	○	○	□	✓ <sup>8)</sup>	✓	✓	–	–	–
<b>1MA6 25</b> . . . . . <b>QQ</b>	○	○	○	○	□	✓ <sup>8)</sup>	✓	✓	–	–	–
<b>1MA6 28</b> . . . . . <b>QQ</b>	○	○	○	○	□	✓ <sup>8)</sup>	✓	✓	–	–	–
<b>1MA6 310</b> . . . . . <b>QQ</b>	○	○	○	○	□	✓ <sup>8)</sup>	✓	✓	–	–	–
<b>1MA6 313</b> . . . . . <b>QQ</b>	○	○	○	○	□	✓ <sup>8)</sup>	✓	✓	–	–	–
<b>1MA6 316</b> . . . . . <b>QQ</b>	–	○	○	○	□ <sup>9)</sup>	–	✓ <sup>10)</sup>	✓	–	–	–
<b>1MA6 317</b> . . . . . <b>QQ</b>	–	○	○	○	□ <sup>9)</sup>	–	✓ <sup>10)</sup>	✓	–	–	–

- Standard version
- Without additional charge
- ✓ With additional charge
- Not possible

Order other voltages with voltage code **9** in the penultimate position and the corresponding order code (see "Special versions" in the "Selection and ordering data" under "Voltages").

Order other types of construction with type of construction code **9** in the final position and the corresponding order code (see "Special versions" in the "Selection and ordering data" under "Types of construction").

For footnotes, see Page 4/23.

# IEC Squirrel-Cage Motors

## Explosion-proof motors

Self-ventilated, in Zone 1 with type of protection "e"  
Cast-iron series 1MA6

### Selection and ordering data (continued)

Order No.	Locked-rotor torque	Locked-rotor current	Breakdown torque	Torque class	Moment of inertia	Noise at rated output		$t_E$ time	
	with direct starting torque	as multiple of rated current	torque			Measuring surface sound pressure level at 50 Hz	Sound pressure level at 50 Hz	for temperature class T1/T2	for temperature class T3
	$T_{LR}/T_{rated}$	$I_{LR}/I_{rated}$	$T_B/T_{rated}$	CL	$J$ kgm <sup>2</sup>	$L_{p(A)}$ dB(A)	$L_{WA}$ dB(A)	$t_E$ s	$t_E$ s
<b>2-pole, 3000 rpm at 50 Hz, 3600 rpm at 60 Hz, temperature class 155 (F), IP55 degree of protection, temperature classes T1 to T3</b>									
1MA6 106-2BAQQ	2.6	7.4	2.8	16	0.0038	62	74	9	8
1MA6 113-2BBQQ	2.1	6.6	2.3	13	0.0055	63	75	10	9
1MA6 130-2BBQQ	1.9	6.8	2.5	13	0.016	68	80	15	13
1MA6 131-2BBQQ	2.2	7.7	2.7	13	0.021	68	80	15	13
1MA6 163-2BBQQ	2.2	7.6	3.1	13	0.034	70	82	29	18
1MA6 164-2BBQQ	2.1	7.6	2.9	13	0.04	70	82	23	12
1MA6 166-2BBQQ	2.3	7.6	3	13	0.052	70	82	23	9
1MA6 183-2BCQQ	2	6.9	3.3	10	0.077	70	83	30	14
1MA6 206-2BCQQ	1.9	6	2.9	10	0.14	71	84	35	14
1MA6 207-2BCQQ	2	6.4	3	10	0.16	71	84	35	10
1MA6 223-2BCQQ	1.8	6.4	2.7	10	0.24	71	84	30	13
1MA6 223-2ACQQ	1.8	7	2.7	10	0.24	71	84	16	–
1MA6 253-2BCQQ	1.5	6.6	2.7	10	0.45	75	89	30	11
1MA6 253-2ACQQ	1.5	6.5	2.7	10	0.45	75	89	18	–
1MA6 280-2BDQQ	1.5	7.1	2.9	7	0.79	77	91	30	23
1MA6 280-2ADQQ	1.5	7.8	2.9	7	0.79	77	91	19	–
1MA6 283-2BDQQ	1.5	7.2	2.8	7	0.92	77	91	27	11
1MA6 283-2ADQQ	1.5	7.5	2.8	7	0.92	77	91	15	–
1MA6 310-2BDQQ	1.4	7.1	2.8	7	1.3	79	93	50	21
1MA6 310-2ADQQ	1.5	7.3	2.9	7	1.3	79	93	30	–
1MA6 313-2BDQQ	1.6	7	2.8	7	1.5	79	93	40	19
1MA6 313-2ADQQ	1.4	7.5	2.7	7	1.5	79	93	21	–
1MA6 316-2BDQQ	1.4	6.8	2.7	7	1.8	79	93	40	11
1MA6 316-2ADQQ	1.6	7.4	2.9	7	1.8	79	93	17	–
1MA6 317-2BDQQ	1.5	7.3	2.5	7	2.3	79	93	30	7
1MA6 317-2ADQQ	1.8	9.3	2.9	7	2.3	79	93	7	–

1) For the following versions T3-output is stamped as standard:  
– order code **A11/A12**  
– voltage code "9"  
Alternative: order code **C30** "T1/T2-output on the rating plate"

2) For connection to 230 V, parallel supply cables are necessary (see the "Introduction" section, "Connection, circuit and connection box").

3) Technical data and dimensions are available for VIK version (order code **K30**) on request (additional charge).

4) The following applies for explosion-proof motors: In the case of the types of construction with shaft extension down, the version "with protective cover" is required. For types of construction with shaft extension pointing upwards, a suitable cover must be implemented to prevent small parts from falling into the fan cover (see the standard IEC/EN 60079-0). The cover must not block the cooling air-flow.

5) If motors 1MA6 183-... to 1MA6 318-... (motor series 1MA6 frame sizes 180 M to 315 L) in types of construction with feet IM B6, IM B7 or IM V6 are fixed to the wall, it is recommended that the motor feet are supported.

6) 1MA6 220-... to 1MA6 318-... motors (motor series 1MA6 frame sizes 225 S to 315 L) are supplied with two screw-in eyebolts in accordance with IM B5, whereby one can be relocated in accordance with IM V1 or IM V3. It is important to note that stress must not be applied perpendicular to the ring plane.

7) The "Second shaft extension" option, order code **K16** is not possible.

8) Type of construction IM V3 is only possible using type of construction code **9** and order code **M1G**.

9) Type of construction IM V6 is only possible using type of construction code **9** and order code **M1E**.

10) 2-pole motors in 60 Hz version available on request.

# IEC Squirrel-Cage Motors

## Explosion-proof motors

Self-ventilated, in Zone 1 with type of protection "e"  
Cast-iron series 1MA6

### Selection and ordering data (continued)

Rated output at		Temperature class	Frame size	Operating values at rated output					Order No.	Price	Weight
50 Hz	60 Hz			Rated speed at 50 Hz	Rated torque at 50 Hz	Efficiency at 50 Hz	Power factor at 50 Hz	Rated current at 380 ... 420 V, 50 Hz			
$P_{rated}$ kW	$P_{rated}$ kW		FS	$n_{rated}$ rpm	$T_{rated}$ Nm	$\eta_{rated}$ %	$\cos\phi_{rated}$	$I_{rated}$ A		m kg	
<b>2-pole, 3000 rpm at 50 Hz, 3600 rpm at 60 Hz, temperature class 155 (F), IP55 degree of protection, temperature classes T1 and T2, with double rating plate (T1/T2 and T3)</b>											
6.5	6.5	T1,T2	132 S	2900	21	85	0.91	12.6	<b>1MA6 131-2BB□□<sup>2)</sup></b>	58	
9.5	9.5	T1,T2	160 M	2920	31	87	0.88	18.6	<b>1MA6 163-2BB□□<sup>2)</sup></b>	96	
13	13	T1,T2	160 M	2910	43	87.5	0.92	24.5	<b>1MA6 164-2BB□□<sup>1) 2)</sup></b>	105	
16	16	T1,T2	160 L	2910	53	87	0.93	30	<b>1MA6 166-2BB□□<sup>1) 2)</sup></b>	115	
19	19	T1,T2	180 M	2935	62	91.1	0.88	36.5	<b>1MA6 183-2BC□□<sup>1)</sup></b>	170	
25	25	T1,T2	200 L	2960	81	90.6	0.86	39	<b>1MA6 206-2BC□□<sup>1)</sup></b>	245	
31	31	T1,T2	200 L	2950	100	91.4	0.88	60	<b>1MA6 207-2BC□□<sup>1)</sup></b>	246	

### Order No. supplements

Motor type	Penultimate position: Voltage code				Final position: Type of construction code						
	50 Hz				Without flange	With flange		With standard flange		With special flange	
	230 VΔ/400 VY	400 VΔ/690 VY	500 VY	500 VΔ	IM B3/6/7/8, IM V6 <sup>3) 4)</sup>	IM B5 <sup>3) 5)</sup> IM V3 <sup>3) 5)</sup>	IM V1 with protective cover <sup>3) 5) 6)</sup>	IM B35	IM B14, <sup>3)</sup> IM V19 <sup>3)</sup>	IM B34	IM B14 IM V19 <sup>3)</sup>
	<b>1</b>	<b>6</b>	<b>3</b>	<b>5</b>	<b>0</b>	<b>1</b>	<b>4</b>	<b>6</b>	<b>2</b>	<b>7</b>	<b>3</b>
<b>1MA6 13</b> . . . . □□	○	○	○	○	□	✓	✓	✓	✓	✓	✓
<b>1MA6 16</b> . . . . □□	○	○	○	○	□	✓	✓	✓	✓	✓	✓
<b>1MA6 18</b> . . . . □□	○	○	○	○	□	✓ <sup>7)</sup>	✓	✓	–	–	–
<b>1MA6 20</b> . . . . □□	○	○	○	○	□	✓ <sup>7)</sup>	✓	✓	–	–	–

- Standard version
- Without additional charge
- ✓ With additional charge
- Not possible

Order other voltages with voltage code **9** in the penultimate position and the corresponding order code (see "Special versions" in the "Selection and ordering data" under "Voltages").

Order other types of construction with type of construction code **9** in the final position and the corresponding order code (see "Special versions" in the "Selection and ordering data" under "Types of construction").

<sup>1)</sup> Utilization according to temperature class 155 (F).

<sup>2)</sup> For the following versions T3-output is stamped as standard:  
– order code **A11/A12**  
– voltage code "9"  
Alternative: order code **C30** "T1/T2-output on the rating plate"

<sup>3)</sup> The following applies for explosion-proof motors: In the case of the types of construction with shaft extension down, the version "with protective cover" is required. For types of construction with shaft extension pointing upwards, a suitable cover must be implemented to prevent small parts from falling into the fan cover (see the standard IEC/EN 60079-0). The cover must not block the cooling air-flow.

<sup>4)</sup> If motors 1MA6 183-... to 1MA6 318-... (motor series 1MA6 frame sizes 180 M to 315 L) in types of construction with feet IM B6, IM B7 or IM V6 are fixed to the wall, it is recommended that the motor feet are supported.

<sup>5)</sup> 1MA6 220-... to 1MA6 318-... motors (motor series 1MA6 frame sizes 225 S to 315 L) are supplied with two screw-in eyebolts in accordance with IM B5, whereby one can be relocated in accordance with IM V1 or IM V3. It is important to note that stress must not be applied perpendicular to the ring plane.

<sup>6)</sup> The "Second shaft extension" option, order code **K16** is not possible.

<sup>7)</sup> Type of construction IM V3 is only possible using type of construction code **9** and order code **M1G**.

# IEC Squirrel-Cage Motors

## Explosion-proof motors

Self-ventilated, in Zone 1 with type of protection "e"  
Cast-iron series 1MA6

### Selection and ordering data (continued)

Order No.	Locked-rotor torque with direct starting torque	Locked-rotor current as multiple of rated current	Breakdown torque	Torque class	Moment of inertia	$t_E$ time	
	$T_{LR}/T_{rated}$	$I_{LR}/I_{rated}$	$T_B/T_{rated}$	CL	$J$ kgm <sup>2</sup>	for temperature class T1/T2 $t_E$ s	for temperature class T3 $t_E$ s
<b>2-pole, 3000 rpm at 50 Hz, 3600 rpm at 60 Hz, temperature class 155 (F), IP55 degree of protection, temperature classes T1 and T2, with double rating plate (T1/T2 and T3)</b>							
<b>1MA6 131-2BB□□</b>	1.9	6.5	2.3	13	0.021	12	7
<b>1MA6 163-2BB□□</b>	1.7	6	2.4	13	0.034	24	–
<b>1MA6 164-2BB□□</b>	1.6	5.8	2.2	13	0.04	16	–
<b>1MA6 166-2BB□□</b>	1.8	5.8	2.3	13	0.052	5	–
<b>1MA6 183-2BC□□</b>	1.6	5.5	2.6	10	0.077	24	–
<b>1MA6 206-2BC□□</b>	1.5	4.8	2.3	10	0.14	28	–
<b>1MA6 207-2BC□□</b>	1.5	4.9	2.3	10	0.16	26	–

# IEC Squirrel-Cage Motors

## Explosion-proof motors

Self-ventilated, in Zone 1 with type of protection "e"  
Cast-iron series 1MA6

### Selection and ordering data (continued)

Rated output at		Temperature class	Frame size	Operating values at rated output					Order No.	Price	Weight
50 Hz	60 Hz			Rated speed at 50 Hz	Rated torque at 50 Hz	Efficiency at 50 Hz	Power factor at 50 Hz	Rated current at 380 ... 420 V, 50 Hz			
$P_{rated}$ kW	$P_{rated}$ kW		FS	$n_{rated}$ rpm	$T_{rated}$ Nm	$\eta_{rated}$ %	$\cos\phi_{rated}$	$I_{rated}$ A	For Order No. supplements for voltage and type of construction, see table below	IM B3 type of construction approx. $m$ kg	
<b>4-pole, 1500 rpm at 50 Hz, 1800 rpm at 60 Hz, temperature class 155 (F), IP55 degree of protection, temperature classes T1 to T3</b>											
2	2	T1,T2,T3	100 L	1420	14	80	0.82	4.5	<b>1MA6 106-4BAQQ</b>	33	
2.5	2.5	T1,T2,T3	100 L	1415	17	81	0.83	5.5	<b>1MA6 107-4BAQQ</b>	36	
3.6	3.6	T1,T2,T3	112 M	1435	24	85	0.83	7.5	<b>1MA6 113-4BAQQ</b>	45	
5	5	T1,T2,T3	132 S	1445	33	86	0.82	10.4	<b>1MA6 130-4BAQQ</b>	55	
6.8	6.8	T1,T2,T3	132 M	1460	44	87	0.82	14	<b>1MA6 133-4BAQQ</b>	62	
10	10	T1,T2,T3	160 M	1455	66	88	0.87	19.7	<b>1MA6 163-4BBQQ</b>	100	
13.5	13.5	T1,T2,T3	160 L	1465	88	89	0.84	27	<b>1MA6 166-4BBQQ</b>	114	
15	15	T3	180 M	1470	97	90.7	0.8	31	<b>1MA6 183-4BCQQ</b>	165	
17.5	17.5	T3	180 L	1470	114	91.6	0.8	36	<b>1MA6 186-4BCQQ</b>	177	
24	24	T3	200 L	1475	155	92.5	0.82	47.5	<b>1MA6 207-4BCQQ</b>	280	
30	30	T3	225 S	1481	193	93.3	0.83	59	<b>1MA6 220-4BCQQ</b>	300	
36	36	T3	225 M	1484	232	93.8	0.84	70 <sup>1)</sup>	<b>1MA6 223-4BCQQ</b>	330	
44	44	T3	250 M	1485	283	94	0.85	83	<b>1MA6 253-4BCQQ</b>	435	
58	58	T3	280 S	1488	372	94.6	0.84	111	<b>1MA6 280-4BCQQ <sup>2)</sup></b>	610	
70	70	T3	280 M	1488	449	94.8	0.85	130	<b>1MA6 283-4BCQQ <sup>2)</sup></b>	660	
84	84	T3	315 S	1492	538	95.4	0.84	158	<b>1MA6 310-4BDQQ</b>	830	
100	100	T3	315 M	1492	640	95.8	0.85	185	<b>1MA6 313-4BDQQ <sup>2)</sup></b>	910	
115	115	T3	315 L	1490	740	95.6	0.86	214	<b>1MA6 316-4BDQQ <sup>2)</sup></b>	1060	
135	135	T3	315 L	1492	868	95.8	0.86	245	<b>1MA6 317-4BDQQ</b>	1200	

### Order No. supplements

Motor type	Penultimate position: Voltage code				Final position: Type of construction code							
	50 Hz				Without flange	With flange			With standard flange		With special flange	
	230 V $\Delta$ /400 VY	400 V $\Delta$ /690 VY	500 VY	500 V $\Delta$	IM B3(6/7/8, IM V6 <sup>3) 4)</sup>	IM B5 <sup>3) 5)</sup>	IM V3 <sup>3) 5)</sup>	IM V1 with protective cover <sup>3) 5) 6)</sup>	IM B35	IM B14 <sup>1,3)</sup>	IM B34	IM B14 IM V19 <sup>3)</sup>
	1	6	3	5	0	1	4	6	2	7	3	
<b>1MA6 10 . . . . QQ</b>	○	○	○	○	□	✓	✓	✓	✓	✓	✓	
<b>1MA6 11 . . . . QQ</b>	○	○	○	○	□	✓	✓	✓	✓	✓	✓	
<b>1MA6 13 . . . . QQ</b>	○	○	○	○	□	✓	✓	✓	✓	✓	✓	
<b>1MA6 16 . . . . QQ</b>	○	○	○	○	□	✓	✓	✓	✓	✓	✓	
<b>1MA6 18 . . . . QQ</b>	○	○	○	○	□	✓ <sup>7)</sup>	✓	✓	–	–	–	
<b>1MA6 20 . . . . QQ</b>	○	○	○	○	□	✓ <sup>7)</sup>	✓	✓	–	–	–	
<b>1MA6 22 . . . . QQ</b>	○	○	○	○	□	✓ <sup>7)</sup>	✓	✓	–	–	–	
<b>1MA6 25 . . . . QQ</b>	○	○	○	○	□	✓ <sup>7)</sup>	✓	✓	–	–	–	
<b>1MA6 28 . . . . QQ</b>	○	○	○	○	□	✓ <sup>7)</sup>	✓	✓	–	–	–	
<b>1MA6 310 . . . . QQ</b>	○	○	○	○	□	✓ <sup>7)</sup>	✓	✓	–	–	–	
<b>1MA6 313 . . . . QQ</b>	○	○	○	○	□	✓ <sup>7)</sup>	✓	✓	–	–	–	
<b>1MA6 316 . . . . QQ</b>	–	○	○	○	□ <sup>8)</sup>	–	✓	✓	–	–	–	
<b>1MA6 317 . . . . QQ</b>	–	○	○	○	□ <sup>8)</sup>	–	✓	✓	–	–	–	

- Standard version
- Without additional charge
- ✓ With additional charge
- Not possible

Order other voltages with voltage code **9** in the penultimate position and the corresponding order code (see "Special versions" in the "Selection and ordering data" under "Voltages").

Order other types of construction with type of construction code **9** in the final position and the corresponding order code (see "Special versions" in the "Selection and ordering data" under "Types of construction").

For footnotes, see Page 4/27.

# IEC Squirrel-Cage Motors

## Explosion-proof motors

Self-ventilated, in Zone 1 with type of protection "e"  
Cast-iron series 1MA6

### Selection and ordering data (continued)

Order No.	Locked-rotor torque	Locked-rotor current	Breakdown torque	Torque class	Moment of inertia	Noise at rated output		$t_E$ time	
	with direct starting torque	as multiple of rated current	torque			Measuring surface sound pressure level at 50 Hz	Sound pressure level at 50 Hz	for temperature class T1/T2	for temperature class T3
	$T_{LR}/T_{rated}$	$I_{LR}/I_{rated}$	$T_B/T_{rated}$	CL	$J$ kgm <sup>2</sup>	$L_{pFA}$ dB(A)	$L_{WA}$ dB(A)	$t_E$ s	$t_E$ s
<b>4-pole, 1500 rpm at 50 Hz, 1800 rpm at 60 Hz, temperature class 155 (F), IP55 degree of protection, temperature classes T1 to T3</b>									
<b>1MA6 106-4BA□□</b>	2.5	6.4	2.7	16	0.0048	53	65	13	11
<b>1MA6 107-4BA□□</b>	2.6	6.4	2.7	16	0.0058	53	65	12	10
<b>1MA6 113-4BA□□</b>	2.6	7.2	2.9	16	0.011	53	65	10	9
<b>1MA6 130-4BA□□</b>	2.7	6.6	3.2	16	0.021	62	74	10	9
<b>1MA6 133-4BA□□</b>	3	7.7	3.6	16	0.027	62	74	10	9
<b>1MA6 163-4BB□□</b>	2.3	6.5	2.7	13	0.052	66	78	17	10
<b>1MA6 166-4BB□□</b>	2.4	6.9	3	13	0.057	66	78	18	9
<b>1MA6 183-4BC□□</b>	1.8	6.1	2.9	10	0.13	63	76	18	11
<b>1MA6 186-4BC□□</b>	1.8	6.4	3	10	0.15	63	76	16	11
<b>1MA6 207-4BC□□</b>	2.1	7.9	3	10	0.24	65	78	20	11
<b>1MA6 220-4BC□□</b>	1.6	6.7	2.7	10	0.44	65	78	13	13
<b>1MA6 223-4BC□□</b>	1.7	6.9	2.8	10	0.52	65	78	12	12
<b>1MA6 253-4BC□□</b>	1.7	7.3	2.5	10	0.79	65	79	18	11
<b>1MA6 280-4BC□□</b>	1.7	6.3	2.5	10	1.4	67	81	30	7
<b>1MA6 283-4BC□□</b>	1.7	7	2.5	10	1.6	67	81	26	6
<b>1MA6 310-4BD□□</b>	1.7	7.7	2.8	7	2.2	69	83	28	8
<b>1MA6 313-4BD□□</b>	1.6	7.2	2.5	7	2.7	69	83	29	7
<b>1MA6 316-4BD□□</b>	1.7	7.5	2.5	7	3.2	69	83	28	5
<b>1MA6 317-4BD□□</b>	1.7	7.8	2.8	7	4.2	69	83	26	7

4

- For connection to 230 V, parallel supply cables are necessary (see the "Introduction" section, "Connection, circuit and connection box").
- Technical data and dimensions are available for VIK version (order code **K30**) on request (additional charge).
- The following applies for explosion-proof motors: In the case of the types of construction with shaft extension down, the version "with protective cover" is required. For types of construction with shaft extension pointing upwards, a suitable cover must be implemented to prevent small parts from falling into the fan cover (see the standard IEC/EN 60079-0). The cover must not block the cooling air-flow.
- If motors 1MA6 183-... to 1MA6 318-... (motor series 1MA6 frame sizes 180 M to 315 L) in types of construction with feet IM B6, IM B7 or IM V6 are fixed to the wall, it is recommended that the motor feet are supported.
- 1MA6 220-... to 1MA6 318-... motors (motor series 1MA6 frame sizes 225 S to 315 L) are supplied with two screw-in eyebolts in accordance with IM B5, whereby one can be relocated in accordance with IM V1 or IM V3. It is important to note that stress must not be applied perpendicular to the ring plane.
- The "Second shaft extension" option, order code **K16** is not possible.
- Type of construction IM V3 is only possible using type of construction code **9** and order code **M1G**.
- Type of construction IM V6 is only possible using type of construction code **9** and order code **M1E**.

# IEC Squirrel-Cage Motors

## Explosion-proof motors

Self-ventilated, in Zone 1 with type of protection "e"  
Cast-iron series 1MA6

### Selection and ordering data (continued)

Rated output at		Temperature class	Frame size	Operating values at rated output					Rated current at 380 ... 420 V, 50 Hz	Order No. supplements for voltage and type of construction, see table below	Price	Weight IM B3 type of construction approx. m kg
50 Hz	60 Hz			Rated speed at 50 Hz	Rated torque at 50 Hz	Efficiency at 50 Hz	Power factor at 50 Hz	Rated current at 380 ... 420 V, 50 Hz				
$P_{rated}$ kW	$P_{rated}$ kW		FS	$n_{rated}$ rpm	$T_{rated}$ Nm	$\eta_{rated}$ %	$\cos\phi_{rated}$	$I_{rated}$ A				
<b>4-pole, 1500 rpm at 50 Hz, 1800 rpm at 60 Hz, temperature class 155 (F), IP55 degree of protection, temperature classes T1 and T2, with double rating plate (T1/T2 and T3)</b>												
17	17	T1,T2	180 M	1460	111	90	0.82	35.5	<b>1MA6 183-4BCQQ<sup>1)</sup></b>		165	
20	20	T1,T2	180 L	1465	130	90.6	0.82	41 <sup>2)</sup>	<b>1MA6 186-4BCQQ<sup>1)</sup></b>		177	
27	27	T1,T2	200 L	1475	175	92.4	0.84	53	<b>1MA6 207-4BCQQ</b>		280	
33	33	T1,T2	225 S	1480	213	93.1	0.84	64 <sup>2)</sup>	<b>1MA6 220-4BCQQ</b>		300	
40	40	T1,T2	225 M	1480	258	93.6	0.85	77 <sup>2)</sup>	<b>1MA6 223-4BCQQ</b>		330	
50	50	T1,T2	250 M	1485	322	93.8	0.86	94	<b>1MA6 253-4BCQQ</b>		435	
68	68	T1,T2	280 S	1485	437	94.5	0.85	131	<b>1MA6 280-4BCQQ<sup>3)</sup></b>		610	
80	80	T1,T2	280 M	1485	514	94.8	0.87	150 <sup>2)</sup>	<b>1MA6 283-4BCQQ<sup>3)</sup></b>		660	
100	100	T1,T2	315 S	1490	641	95.3	0.85	188	<b>1MA6 310-4BDQQ</b>		830	
120	120	T1,T2	315 M	1488	770	95.7	0.86	222 <sup>2)</sup>	<b>1MA6 313-4BDQQ<sup>3)</sup></b>		910	
135	135	T1,T2	315 L	1488	868	95.5	0.86	248	<b>1MA6 316-4BDQQ<sup>3)</sup></b>		1060	
165	165	T1,T2	315 L	1485	1061	95.8	0.87	305	<b>1MA6 317-4BDQQ</b>		1200	

### Order No. supplements

Motor type	Penultimate position: Voltage code				Final position: Type of construction code							
	50 Hz				Without flange	With flange			With standard flange		With special flange	
	230 V $\Delta$ /400 VY	400 V $\Delta$ /690 VY	500 VY	500 V $\Delta$	IM B3/6/7/8, IM V6 <sup>4) 5)</sup>	IM B5, IM V3 <sup>4) 6)</sup>	IM V1 with protective cover <sup>4) 6) 7)</sup>	IM B35	IM B14, IM V19 <sup>4)</sup>	IM B34	IM B14 IM V19 <sup>4)</sup>	
	1	6	3	5	0	1	4	6	2	7	3	
<b>1MA6 18</b> . . . . □□	○	○	○	○	□	✓ <sup>8)</sup>	✓	✓	–	–	–	
<b>1MA6 20</b> . . . . □□	○	○	○	○	□	✓ <sup>8)</sup>	✓	✓	–	–	–	
<b>1MA6 22</b> . . . . □□	○	○	○	○	□	✓ <sup>8)</sup>	✓	✓	–	–	–	
<b>1MA6 25</b> . . . . □□	○	○	○	○	□	✓ <sup>8)</sup>	✓	✓	–	–	–	
<b>1MA6 28</b> . . . . □□	○	○	○	○	□	✓ <sup>8)</sup>	✓	✓	–	–	–	
<b>1MA6 310</b> . . . . □□	○	○	○	○	□	✓ <sup>8)</sup>	✓	✓	–	–	–	
<b>1MA6 313</b> . . . . □□	○	○	○	○	□	✓ <sup>8)</sup>	✓	✓	–	–	–	
<b>1MA6 316</b> . . . . □□	–	○	○	○	□ <sup>9)</sup>	–	✓	✓	–	–	–	
<b>1MA6 317</b> . . . . □□	–	○	○	○	□ <sup>9)</sup>	–	✓	✓	–	–	–	

- Standard version
- Without additional charge
- ✓ With additional charge
- Not possible

Order other voltages with voltage code **9** in the penultimate position and the corresponding order code (see "Special versions" in the "Selection and ordering data" under "Voltages").

Order other types of construction with type of construction code **9** in the final position and the corresponding order code (see "Special versions" in the "Selection and ordering data" under "Types of construction").

- 1) Utilization according to temperature class 155 (F).
- 2) For connection to 230 V, parallel supply cables are necessary (see the "Introduction" section, "Connection, circuit and connection box").
- 3) Technical data and dimensions are available for VIK version (order code **K30**) on request (additional charge).
- 4) The following applies for explosion-proof motors: In the case of the types of construction with shaft extension down, the version "with protective cover" is required. For types of construction with shaft extension pointing upwards, a suitable cover must be implemented to prevent small parts from falling into the fan cover (see the standard IEC/EN 60079-0). The cover must not block the cooling air-flow.

- 5) If motors 1MA6 183-... to 1MA6 318-... (motor series 1MA6 frame sizes 180 M to 315 L) in types of construction with feet IM B6, IM B7 or IM V6 are fixed to the wall, it is recommended that the motor feet are supported.
- 6) 1MA6 220-... to 1MA6 318-... motors (motor series 1MA6 frame sizes 225 S to 315 L) are supplied with two screw-in eyebolts in accordance with IM B5, whereby one can be relocated in accordance with IM V1 or IM V3. It is important to note that stress must not be applied perpendicular to the ring plane.
- 7) The "Second shaft extension" option, order code **K16** is not possible.
- 8) Type of construction IM V3 is only possible using type of construction code **9** and order code **M1G**.
- 9) Type of construction IM V6 is only possible using type of construction code **9** and order code **M1E**.



# IEC Squirrel-Cage Motors

## Explosion-proof motors

Self-ventilated, in Zone 1 with type of protection "e"  
Cast-iron series 1MA6

### Selection and ordering data (continued)

Order No.	Locked-rotor torque with direct starting torque	Locked-rotor current as multiple of rated current	Breakdown torque torque	Torque class	Moment of inertia	$t_E$ time	
	$T_{LR}/T_{rated}$	$I_{LR}/I_{rated}$	$T_B/T_{rated}$	CL	$J$ kgm <sup>2</sup>	for temperature class T1/T2 $t_E$ s	for temperature class T3 $t_E$ s
<b>4-pole, 1500 rpm at 50 Hz, 1800 rpm at 60 Hz, temperature class 155 (F), IP55 degree of protection, temperature classes T1 and T2, with double rating plate (T1/T2 and T3)</b>							
<b>1MA6 183-4BC□□</b>	1.6	5.3	2.4	10	0.13	13	–
<b>1MA6 186-4BC□□</b>	1.6	5.6	2.6	10	0.15	13	–
<b>1MA6 207-4BC□□</b>	1.9	7.1	2.7	10	0.24	19	–
<b>1MA6 220-4BC□□</b>	1.4	6.2	2.5	10	0.44	11	–
<b>1MA6 223-4BC□□</b>	1.5	6.2	2.5	10	0.52	10	–
<b>1MA6 253-4BC□□</b>	1.5	6.4	2.1	10	0.79	15	–
<b>1MA6 280-4BC□□</b>	1.5	5.3	2.1	10	1.4	23	–
<b>1MA6 283-4BC□□</b>	1.5	6	2.2	10	1.6	20	–
<b>1MA6 310-4BD□□</b>	1.4	6.5	2.4	7	2.2	24	–
<b>1MA6 313-4BD□□</b>	1.3	6	2.1	7	2.7	24	–
<b>1MA6 316-4BD□□</b>	1.4	6.4	2.1	7	3.2	21	–
<b>1MA6 317-4BD□□</b>	1.5	6.3	2.3	7	4.2	17	–

# IEC Squirrel-Cage Motors

## Explosion-proof motors

Self-ventilated, in Zone 1 with type of protection "e"  
Cast-iron series 1MA6

### Selection and ordering data (continued)

Rated output at		Temperature class	Frame size	Operating values at rated output					Rated current at 380 ... 420 V, 50 Hz	Order No. For Order No. supplements for voltage and type of construction, see table below	Price	Weight IM B3 type of construction approx. m kg
50 Hz	60 Hz			Rated speed at 50 Hz	Rated torque at 50 Hz	Efficiency at 50 Hz	Power factor at 50 Hz	Rated current at 380 ... 420 V, 50 Hz				
$P_{rated}$ kW	$P_{rated}$ kW		FS	$n_{rated}$ rpm	$T_{rated}$ Nm	$\eta_{rated}$ %	$\cos\phi_{rated}$	$I_{rated}$ A				
<b>6-pole, 1000 rpm at 50 Hz, 1200 rpm at 60 Hz, temperature class 155 (F), IP55 degree of protection, temperature classes T1 to T3</b>												
1.3	1.3	T1,T2,T3	100 L	935	13	77	0.73	3.35	<b>1MA6 106-6BA□□</b>		33	
1.9	1.9	T1,T2,T3	112 M	940	19	79	0.76	4.7	<b>1MA6 113-6BB□□</b>		40	
2.6	2.6	T1,T2,T3	132 S	945	26	79	0.75	6.5	<b>1MA6 130-6BB□□</b>		50	
3.5	3.5	T1,T2,T3	132 M	955	35	81	0.72	9	<b>1MA6 133-6BB□□</b>		57	
4.8	4.8	T1,T2,T3	132 M	950	48	83	0.76	11.4	<b>1MA6 134-6BB□□</b>		66	
6.6	6.6	T1,T2,T3	160 M	960	65	85	0.75	14.9	<b>1MA6 163-6BB□□</b>		103	
9.7	9.7	T1,T2,T3	160 L	965	96	88	0.76	21	<b>1MA6 166-6BB□□</b>		122	
13.2	13.2	T1,T2,T3	180 L	975	129	89.6	0.78	28.5	<b>1MA6 186-6BC□□</b>		177	
16.5	16.5	T1,T2,T3	200 L	980	161	90.5	0.81	34.5	<b>1MA6 206-6BC□□</b>		220	
20	20	T1,T2,T3	200 L	980	195	90.8	0.82	41	<b>1MA6 207-6BC□□</b>		235	
27	27	T1,T2,T3	225 M	980	263	92.5	0.82	54	<b>1MA6 223-6BC□□</b>		305	
33	33	T1,T2,T3	250 M	985	320	93	0.83	66	<b>1MA6 253-6BC□□</b>		410	
40	40	T1,T2,T3	280 S	990	386	93.3	0.85	77	<b>1MA6 280-6BC□□</b>		540	
46	46	T3	280 M	988	445	93.5	0.86	86	<b>1MA6 283-6BC□□</b>		580	
64	64	T3	315 S	991	617	94.3	0.84	124	<b>1MA6 310-6BC□□</b>		770	
76	76	T3	315 M	991	732	94.6	0.84	146	<b>1MA6 313-6BC□□</b>		830	
92	92	T3	315 L	991	887	95	0.85	172	<b>1MA6 316-6BC□□</b>		970	
110	110	T3	315 L	991	1060	95.2	0.84	210	<b>1MA6 317-6BC□□</b> <sup>1)</sup>		1060	
125	125	T3	315 L	991	1210	95.2	0.86	220	<b>1MA6 318-6BC□□</b> <sup>1)2)</sup>		1100	

### Order No. supplements

Motor type	Penultimate position: Voltage code				Final position: Type of construction code							
	50 Hz				Without flange	With flange			With standard flange		With special flange	
	230 VΔ/400 VY	400 VΔ/690 VY	500 VY	500 VΔ	IM B3/6/7/8, IM V6 <sup>3)4)</sup>	IM B5, IM V3 <sup>3)5)</sup>	IM V1 with protective cover <sup>3)5)6)</sup>	IM B35	IM B14, IM V19 <sup>3)</sup>	IM B34	IM B14 IM V19 <sup>3)</sup>	
	For delta connection, overload protection with phase-failure protection must be provided.											
	<b>1</b>	<b>6</b>	<b>3</b>	<b>5</b>	<b>0</b>	<b>1</b>	<b>4</b>	<b>6</b>	<b>2</b>	<b>7</b>	<b>3</b>	
<b>1MA6 10</b> . . . . □□	○	○	○	○	□	✓	✓	✓	✓	✓	✓	
<b>1MA6 11</b> . . . . □□	○	○	○	○	□	✓	✓	✓	✓	✓	✓	
<b>1MA6 13</b> . . . . □□	○	○	○	○	□	✓	✓	✓	✓	✓	✓	
<b>1MA6 16</b> . . . . □□	○	○	○	○	□	✓	✓	✓	✓	✓	✓	
<b>1MA6 18</b> . . . . □□	○	○	○	○	□	✓ <sup>7)</sup>	✓	✓	-	-	-	
<b>1MA6 20</b> . . . . □□	○	○	○	○	□	✓ <sup>7)</sup>	✓	✓	-	-	-	
<b>1MA6 22</b> . . . . □□	○	○	○	○	□	✓ <sup>7)</sup>	✓	✓	-	-	-	
<b>1MA6 25</b> . . . . □□	○	○	○	○	□	✓ <sup>7)</sup>	✓	✓	-	-	-	
<b>1MA6 28</b> . . . . □□	○	○	○	○	□	✓ <sup>7)</sup>	✓	✓	-	-	-	
<b>1MA6 310</b> . . . . □□	○	○	○	○	□	✓ <sup>7)</sup>	✓	✓	-	-	-	
<b>1MA6 313</b> . . . . □□	○	○	○	○	□	✓ <sup>7)</sup>	✓	✓	-	-	-	
<b>1MA6 316</b> . . . . □□	-	○	○	○	□ <sup>8)</sup>	-	✓	✓	-	-	-	
<b>1MA6 317</b> . . . . □□												
<b>1MA6 318</b> . . . . □□												

- Standard version
- Without additional charge
- ✓ With additional charge
- Not possible

Order other voltages with voltage code **9** in the penultimate position and the corresponding order code (see "Special versions" in the "Selection and ordering data" under "Voltages").

Order other types of construction with type of construction code **9** in the final position and the corresponding order code (see "Special versions" in the "Selection and ordering data" under "Types of construction").

For footnotes, see Page 4/31.

# IEC Squirrel-Cage Motors

## Explosion-proof motors

Self-ventilated, in Zone 1 with type of protection "e"  
Cast-iron series 1MA6

### Selection and ordering data (continued)

Order No.	Locked-rotor torque	Locked-rotor current	Breakdown torque	Torque class	Moment of inertia	Noise at rated output		$t_E$ time	
	with direct starting as multiple of rated torque	as multiple of rated current	torque			Measuring surface sound pressure level at 50 Hz	Sound pressure level at 50 Hz	for temperature class T1/T2	for temperature class T3
	$T_{LR}/T_{rated}$	$I_{LR}/I_{rated}$	$T_B/T_{rated}$	CL	$J$ kgm <sup>2</sup>	$L_{dFA}$ dB(A)	$L_{WA}$ dB(A)	$t_E$ s	$t_E$ s
<b>6-pole, 1000 rpm at 50 Hz, 1200 rpm at 60 Hz, temperature class 155 (F), IP55 degree of protection, temperature classes T1 to T3</b>									
<b>1MA6 106-6BA□□</b>	2.4	4.8	2.5	16	0.0063	47	59	26	26
<b>1MA6 113-6BB□□</b>	2.3	5	2.5	13	0.011	52	64	19	16
<b>1MA6 130-6BB□□</b>	1.8	4.4	2.4	13	0.015	63	75	21	18
<b>1MA6 133-6BB□□</b>	2.3	5.1	2.8	13	0.019	63	75	16	13
<b>1MA6 134-6BB□□</b>	2.4	5.6	2.8	13	0.025	63	75	13	11
<b>1MA6 163-6BB□□</b>	2.7	6.4	3.1	13	0.041	66	78	18	9
<b>1MA6 166-6BB□□</b>	2.8	7.7	2.2	13	0.055	66	78	15	8
<b>1MA6 186-6BC□□</b>	1.6	5.4	2.5	10	0.2	66	78	22	18
<b>1MA6 206-6BC□□</b>	1.7	5.4	2.6	10	0.29	66	78	23	19
<b>1MA6 207-6BC□□</b>	1.7	5.6	2.6	10	0.33	66	78	22	17
<b>1MA6 223-6BC□□</b>	1.6	5.6	2.5	10	0.57	66	78	15	15
<b>1MA6 253-6BC□□</b>	1.6	5.3	2.4	10	0.89	60	74	16	16
<b>1MA6 280-6BC□□</b>	1.5	6.2	2.6	10	1.3	60	74	13	13
<b>1MA6 283-6BC□□</b>	1.6	6.5	2.5	10	1.5	60	74	0	12
<b>1MA6 310-6BC□□</b>	1.7	6.2	2.5	10	2.4	63	77	0	14
<b>1MA6 313-6BC□□</b>	1.7	6.4	2.5	10	2.9	63	77	0	8
<b>1MA6 316-6BC□□</b>	1.7	6.5	2.5	10	3.5	63	77	0	9
<b>1MA6 317-6BC□□</b>	1.7	6.8	2.5	10	4.3	63	77	0	6
<b>1MA6 318-6BC□□</b>	1.6	7	2.5	10	4.9	63	77	0	6

4

- 1) Technical data and dimensions are available for VIK version (order code **K30**) on request (additional charge).
- 2) Only certified for rated voltage of 400 V.
- 3) The following applies for explosion-proof motors: In the case of the types of construction with shaft extension down, the version "with protective cover" is required. For types of construction with shaft extension pointing upwards, a suitable cover must be implemented to prevent small parts from falling into the fan cover (see the standard IEC/EN 60079-0). The cover must not block the cooling air-flow.
- 4) If motors 1MA6 183-... to 1MA6 318-... (motor series 1MA6 frame sizes 180 M to 315 L) in types of construction with feet IM B6, IM B7 or IM V6 are fixed to the wall, it is recommended that the motor feet are supported.
- 5) 1MA6 220-... to 1MA6 318-... motors (motor series 1MA6 frame sizes 225 S to 315 L) are supplied with two screw-in eyebolts in accordance with IM B5, whereby one can be relocated in accordance with IM V1 or IM V3. It is important to note that stress must not be applied perpendicular to the ring plane.
- 6) The "Second shaft extension" option, order code **K16** is not possible.
- 7) Type of construction IM V3 is only possible using type of construction code **9** and order code **M1G**.
- 8) Type of construction IM V6 is only possible using type of construction code **9** and order code **M1E**.

# IEC Squirrel-Cage Motors

## Explosion-proof motors

Self-ventilated, in Zone 1 with type of protection "e"  
Cast-iron series 1MA6

### Selection and ordering data (continued)

Rated output at		Temperature class	Frame size	Operating values at rated output					Rated current at 380 ... 420 V, 50 Hz	Order No. supplements for voltage and type of construction, see table below	Price	Weight IM B3 type of construction approx. m kg
50 Hz	60 Hz			Rated speed at 50 Hz	Rated torque at 50 Hz	Efficiency at 50 Hz	Power factor at 50 Hz	Rated current at 380 ... 420 V, 50 Hz				
$P_{rated}$ kW	$P_{rated}$ kW		FS	$n_{rated}$ rpm	$T_{rated}$ Nm	$\eta_{rated}$ %	$\cos\phi_{rated}$	$I_{rated}$ A				
<b>6-pole, 1000 rpm at 50 Hz, 1200 rpm at 60 Hz, temperature class 155 (F), IP55 degree of protection, temperature classes T1 and T2, with double rating plate (T1/T2 and T3)</b>												
50	50	T1,T2	280 M	987	484	93.3	0.86	96	<b>1MA6 283-6BC□□</b>		580	
68	68	T1,T2	315 S	990	656	94.2	0.85	131	<b>1MA6 310-6BC□□</b>		770	
82	82	T1,T2	315 M	990	791	94.5	0.84	158	<b>1MA6 313-6BC□□</b>		830	
98	98	T1,T2	315 L	990	945	94.8	0.85	185	<b>1MA6 316-6BC□□</b>		970	
120	120	T1,T2	315 L	990	1160	95	0.85	230	<b>1MA6 317-6BC□□<sup>1)</sup></b>		1060	
135	135	T1,T2	315 L	990	1300	95	0.86	240 <sup>2)</sup>	<b>1MA6 318-6BC□□<sup>1)</sup></b>		1100	

### Order No. supplements

Motor type	Penultimate position: Voltage code				Final position: Type of construction code							
	50 Hz				Without flange	With flange			With standard flange		With special flange	
	230 VΔ/400 VY	400 VΔ/690 VY	500 VY	500 VΔ	IM B3/6/7/8, IM V6 <sup>3) 4)</sup>	IM B5, IM V3 <sup>3) 5)</sup>	IM V1 with protective cover <sup>3) 5) 6)</sup>	IM B35	IM B14, IM V19 <sup>3)</sup>	IM B34	IM B14 IM V19 <sup>3)</sup>	
	For delta connection, overload protection with phase-failure protection must be provided.											
	<b>1</b>	<b>6</b>	<b>3</b>	<b>5</b>	<b>0</b>	<b>1</b>	<b>4</b>	<b>6</b>	<b>2</b>	<b>7</b>	<b>3</b>	
<b>1MA6 28</b> - . . . . □□	○	○	○	○	□	✓ <sup>7)</sup>	✓	✓	-	-	-	
<b>1MA6 310</b> - . . . . □□	○	○	○	○	□	✓ <sup>7)</sup>	✓	✓	-	-	-	
<b>1MA6 313</b> - . . . . □□	○	○	○	○	□	✓ <sup>7)</sup>	✓	✓	-	-	-	
<b>1MA6 316</b> - . . . . □□	-	○	○	○	□ <sup>8)</sup>	-	✓	✓	-	-	-	
<b>1MA6 317</b> - . . . . □□	-	-	-	-	-	-	-	-	-	-	-	
<b>1MA6 318</b> - . . . . □□	-	-	-	-	-	-	-	-	-	-	-	

- Standard version
- Without additional charge
- ✓ With additional charge
- Not possible

Order other voltages with voltage code **9** in the penultimate position and the corresponding order code (see "Special versions" in the "Selection and ordering data" under "Voltages").

Order other types of construction with type of construction code **9** in the final position and the corresponding order code (see "Special versions" in the "Selection and ordering data" under "Types of construction").

- 1) Technical data and dimensions are available for VIK version (order code **K30**) on request (additional charge).
- 2) Only certified for rated voltage of 400 V.
- 3) The following applies for explosion-proof motors: In the case of the types of construction with shaft extension down, the version "with protective cover" is required. For types of construction with shaft extension pointing upwards, a suitable cover must be implemented to prevent small parts from falling into the fan cover (see the standard IEC/EN 60079-0). The cover must not block the cooling air-flow.
- 4) If motors 1MA6 183-... to 1MA6 318-... (motor series 1MA6 frame sizes 180 M to 315 L) in types of construction with feet IM B6, IM B7 or IM V6 are fixed to the wall, it is recommended that the motor feet are supported.

- 5) 1MA6 220-... to 1MA6 318-... motors (motor series 1MA6 frame sizes 225 S to 315 L) are supplied with two screw-in eyebolts in accordance with IM B5, whereby one can be relocated in accordance with IM V1 or IM V3. It is important to note that stress must not be applied perpendicular to the ring plane.
- 6) The "Second shaft extension" option, order code **K16** is not possible.
- 7) Type of construction IM V3 is only possible using type of construction code **9** and order code **M1G**.
- 8) Type of construction IM V6 is only possible using type of construction code **9** and order code **M1E**.

# IEC Squirrel-Cage Motors

## Explosion-proof motors

Self-ventilated, in Zone 1 with type of protection "e"  
Cast-iron series 1MA6

### Selection and ordering data (continued)

Order No.	Locked-rotor torque with direct starting torque	Locked-rotor current as multiple of rated current	Breakdown torque torque	Torque class	Moment of inertia	$t_E$ time	
	$T_{LR}/T_{rated}$	$I_{LR}/I_{rated}$	$T_B/T_{rated}$	CL	$J$ kgm <sup>2</sup>	for temperature class T1/T2 $t_E$ s	for temperature class T3 $t_E$ s
<b>6-pole, 1000 rpm at 50 Hz, 1200 rpm at 60 Hz, temperature class 155 (F), IP55 degree of protection, temperature classes T1 and T2, with double rating plate (T1/T2 and T3)</b>							
<b>1MA6 283-6BC□□</b>	1.5	5.8	2.3	10	1.5	14	–
<b>1MA6 310-6BC□□</b>	1.6	5.9	2.3	10	2.4	22	–
<b>1MA6 313-6BC□□</b>	1.6	5.9	2.3	10	2.9	18	–
<b>1MA6 316-6BC□□</b>	1.6	6.1	2.3	10	3.5	20	–
<b>1MA6 317-6BC□□</b>	1.6	6.2	2.3	10	4.3	16	–
<b>1MA6 318-6BC□□</b>	1.5	6.5	2.3	10	4.9	17	–

# IEC Squirrel-Cage Motors

## Explosion-proof motors

Self-ventilated in Zone 1 with type of protection "de"  
Cast-iron series 1MJ6 and 1MJ7

### Selection and ordering data

Rated output at		Frame size	Operating values at rated output					Power factor at 50 Hz	Rated current at 400 V, 50 Hz	Order No. For Order No. supplements for voltage and type of construction, see table below	Price	Weight IM B3 type of construction approx. <i>m</i> kg
50 Hz	60 Hz		Rated speed at 50 Hz	Rated torque at 50 Hz	Efficiency at 50 Hz <sup>1)</sup>							
$P_{rated}$ kW	$P_{rated}$ kW	FS	$n_{rated}$ rpm	$T_{rated}$ Nm	$\eta_{rated}$ %	$\cos\phi_{rated}$	$I_{rated}$ A					
<b>2-pole, 3000 rpm at 50 Hz, 3600 rpm at 60 Hz, temperature class 155 (F), IP55 degree of protection, temperature classes T1 to T4</b>												
0.37	0.43	71 M	2750	1.3	67	0.81	0.98	<b>1MJ6 070-2CA□□</b>			19	
0.55	0.63	71 M	2790	1.9	71	0.81	1.38	<b>1MJ6 073-2CA□□</b>			20	
0.75	0.86	80 M	2840	2.5	72	0.86	1.75	<b>1MJ6 080-2CA□□</b>			24	
1.1	1.3	80 M	2835	3.7	74	0.87	2.45	<b>1MJ6 083-2CA□□</b>			26	
1.5	1.75	90 L	2850	5	78	0.84	3.3	<b>1MJ6 096-2CA□□</b>			32	
2.2	2.55	90 L	2860	7.4	80	0.86	4.6	<b>1MJ6 097-2CA□□</b>			35	
3	3.45	100 L	2885	9.9	82	0.85	6.2	<b>1MJ6 106-2CA□□</b>			44	
4	4.6	112 M	2895	13	84	0.88	7.8	<b>1MJ6 113-2CA□□</b>			57	
5.5	6.3	132 S	2925	18	85	0.89	10.5	<b>1MJ6 130-2CA□□</b>			75	
7.5	8.6	132 S	2930	24	87	0.89	14.5	<b>1MJ6 131-2CA□□</b>			82	
11	12.6	160 M	2940	36	88	0.88	20.5	<b>1MJ6 163-2CA□□</b>			123	
15	17.3	160 M	2940	49	89	0.91	26.5	<b>1MJ6 164-2CA□□</b>			134	
18.5	21.3	160 L	2940	60	91	0.91	32.5	<b>1MJ6 166-2CA□□</b>			161	
22	24.5	180 M	2940	71	92	0.88	39	<b>1MJ6 183-2CA□□</b>			175	
30	33.5	200 L	2940	97	92.3	0.89	53	<b>1MJ6 206-2CA□□</b>			250	
37	41.5	200 L	2945	120	92.8	0.9	64	<b>1MJ6 207-2CA□□</b>			266	
45	51	225 M	2955	145	93.9	0.9	77 <sup>1)</sup>	<b>1MJ7 223-2CB□□</b>			335	
55	62	250 M	2965	177	94	0.9	93	<b>1MJ7 253-2CB□□</b>			445	
75	84	280 S	2975	241	94.7	0.9	128 <sup>1)</sup>	<b>1MJ7 280-2CC□□</b>			600	
90	101	280 M	2975	289	95.1	0.91	150 <sup>1)</sup>	<b>1MJ7 283-2CC□□</b>			640	
110	123	315 S	2980	353	94.8	0.9	186 <sup>1)</sup>	<b>1MJ7 310-2CC□□</b>			840	
132	148	315 M	2980	423	95.1	0.9	225 <sup>1)</sup>	<b>1MJ7 313-2CC□□</b>			900	

### Order No. supplements

Motor type	Penultimate position: Voltage code				Final position: Type of construction code							
	50 Hz				Without flange		With flange			With standard flange		With special flange
	230 VΔ/400 VY	400 VΔ/690 VY	500 VY	500 VΔ	IM B3(6/7/8, IM V6 <sup>2)3)</sup>	IM B5 <sup>2)4)</sup> , IM V3 <sup>2)4)</sup>	IM V1 with protective cover <sup>2)4)5)</sup>	IM B35	IM B14 <sup>1,2)</sup> , IM V19 <sup>2)</sup>	IM B34	IM B14, IM V19 <sup>2)</sup>	
1	6	3	5	0	1	4	6	2	7	3		
<b>1MJ6 07</b> . . . . □□	○	○	○	–	□	✓	✓	✓	✓	✓	✓	
<b>1MJ6 08</b> . . . . □□	○	○	○	–	□	✓	✓	✓	✓	✓	✓	
<b>1MJ6 09</b> . . . . □□	○	○	○	–	□	✓	✓	✓	✓	✓	–	
<b>1MJ6 10</b> . . . . □□	○	○	○	○	□	✓	✓	✓	–	–	–	
<b>1MJ6 11</b> . . . . □□	○	○	○	○	□	✓	✓	✓	–	–	–	
<b>1MJ6 13</b> . . . . □□	○	○	○	○	□	✓	✓	✓	–	–	–	
<b>1MJ6 16</b> . . . . □□	○	○	○	○	□	✓	✓	✓	–	–	–	
<b>1MJ6 18</b> . . . . □□	○	○	○	○	□	✓ <sup>6)</sup>	✓	✓	–	–	–	
<b>1MJ6 20</b> . . . . □□	○	○	○	○	□	✓ <sup>6)</sup>	✓	✓	–	–	–	
<b>1MJ7 22</b> . . . . □□	○	○	○	○	□	✓ <sup>6)</sup>	✓	✓	–	–	–	
<b>1MJ7 25</b> . . . . □□	○	○	○	○	□	✓ <sup>6)</sup>	✓	✓	–	–	–	
<b>1MJ7 28</b> . . . . □□	○	○	○	○	□	✓ <sup>6)</sup>	✓	✓	–	–	–	
<b>1MJ7 31</b> . . . . □□	○	○	○	○	□	✓ <sup>6)</sup>	✓	✓	–	–	–	

- Standard version
- Without additional charge
- ✓ With additional charge
- Not possible

Order other voltages with voltage code **9** in the penultimate position and the corresponding order code (see "Special versions" in the "Selection and ordering data" under "Voltages").

Order other types of construction with type of construction code **9** in the final position and the corresponding order code (see "Special versions" in the "Selection and ordering data" under "Types of construction").

For footnotes, see Page 4/35.

# IEC Squirrel-Cage Motors

## Explosion-proof motors

Self-ventilated in Zone 1 with type of protection "de"  
Cast-iron series 1MJ6 and 1MJ7

### Selection and ordering data (continued)

Order No.	Locked-rotor torque with direct starting torque	Locked-rotor current as multiple of rated current	Breakdown torque	Torque class	Moment of inertia	Noise at rated output	
	$T_{LR}/T_{rated}$	$I_{LR}/I_{rated}$	$T_B/T_{rated}$	CL	$J$ kgm <sup>2</sup>	Measuring surface sound pressure level at 50 Hz $L_{pFA}$ dB(A)	Sound pressure level at 50 Hz $L_{WA}$ dB(A)
<b>2-pole, 3000 rpm at 50 Hz, 3600 rpm at 60 Hz, temperature class 155 (F), IP55 degree of protection, temperature classes T1 to T4</b>							
1MJ6 070-2CA□□	2.3	4.3	2.3	16	0.00035	52	63
1MJ6 073-2CA□□	2.3	5.3	2.3	16	0.00045	52	63
1MJ6 080-2CA□□	2.4	6.3	2.3	16	0.00085	56	67
1MJ6 083-2CA□□	2.6	6.3	2.3	16	0.0011	56	67
1MJ6 096-2CA□□	2.5	6.7	2.5	16	0.0015	60	72
1MJ6 097-2CA□□	2.8	7.1	2.8	16	0.002	60	72
1MJ6 106-2CA□□	2.8	7.7	3	16	0.0038	62	74
1MJ6 113-2CA□□	2.4	7.6	2.8	16	0.0055	63	75
1MJ6 130-2CA□□	2	5.9	2.6	16	0.01	68	80
1MJ6 131-2CA□□	2.3	6.9	2.6	16	0.01	68	80
1MJ6 163-2CA□□	2.1	6.5	2.6	16	0.03	70	82
1MJ6 164-2CA□□	2.2	6.6	3.1	16	0.04	70	82
1MJ6 166-2CA□□	2.4	7	3.3	16	0.05	70	82
1MJ6 183-2CA□□	2.5	6.9	3.2	16	0.07	70	83
1MJ6 206-2CA□□	2.4	6.5	2.8	16	0.14	71	84
1MJ6 207-2CA□□	2.4	7.7	2.8	16	0.16	71	84
1MJ7 223-2CB□□	2.3	6.9	2.7	13	0.24	71	84
1MJ7 253-2CB□□	2.1	6.9	2.8	13	0.45	75	89
1MJ7 280-2CC□□	1.9	7	2.7	10	0.79	77	91
1MJ7 283-2CC□□	2	7	2.7	10	0.92	77	91
1MJ7 310-2CC□□	1.8	7	2.8	10	1.3	79	93
1MJ7 313-2CC□□	1.9	7	2.8	10	1.5	79	93

The 1MJ6/1MJ7 motors can also be ordered for use with type of protection Ex d/de (Zone 1)/dust-Ex Zone 21, as well as for Zone 22 for conducting dust:

Mains-fed operation – order code **M76**

Converter-fed operation with derating – order code **M77**

See "Special versions" in the "Selection and ordering data" under "Options".

Other versions up to 900 kW as 2-pole motors as DN series with Order No. 1PS4 (Ex de IIB), 1PS5 (Ex de IIC) available; also higher outputs and other numbers of poles possible.

Place request with:

Loher GmbH (a Siemens company)

Hans-Loher-Str. 32

94099 Ruhstorf/Rott

<http://www.loher.com>

- For connection to 230 V, parallel feeders are necessary (see the "Introduction" section, "Connection, circuit and connection box").
- The following applies for explosion-proof motors: In the case of the types of construction with shaft extension down, the version "with protective cover" is required. For types of construction with shaft extension pointing upwards, a suitable cover must be implemented to prevent small parts from falling into the fan cover (see the standard IEC/EN 60079-0). The cover must not block the cooling air-flow.
- If motors 1MJ6 183-... to 1MJ7 313-... (motor series 1MJ6 frame size 180 M and above to 1MJ7 frame size 315 M) in types of construction with feet IM B6, IM B7 or IM V6 are fixed to the wall, it is recommended that the motor feet are supported.
- 1MJ7 220-... to 1MJ7 313-... motors (motor series 1MJ7 frame sizes 225 S to 315 M) are supplied with two screw-in eyebolts in accordance with IM B5, whereby one can be relocated in accordance with IM V1 or IM V3. It is important to note that stress must not be applied perpendicular to the ring plane.
- The "Second shaft extension" option, order code **K16** is not possible.
- Type of construction IM V3 is only possible using type of construction code **9** and order code **M1G**.

# IEC Squirrel-Cage Motors

## Explosion-proof motors

Self-ventilated in Zone 1 with type of protection "de"  
Cast-iron series 1MJ6 and 1MJ7

### Selection and ordering data (continued)

Rated output at		Frame size	Operating values at rated output					Power factor at 50 Hz	Rated current at 400 V, 50 Hz	Order No. For Order No. supplements for voltage and type of construction, see table below	Price	Weight IM B3 type of construction approx. m kg
50 Hz	60 Hz		Rated speed at 50 Hz	Rated torque at 50 Hz	Efficiency at 50 Hz <sup>1)</sup>							
$P_{rated}$ kW	$P_{rated}$ kW	FS	$n_{rated}$ rpm	$T_{rated}$ Nm	$\eta_{rated}$ %	$\cos\phi_{rated}$	$I_{rated}$ A					
<b>4-pole, 1500 rpm at 50 Hz, 1800 rpm at 60 Hz, temperature class 155 (F), IP55 degree of protection, temperature classes T1 to T4</b>												
0.25	0.29	71 M	1325	1.8	60	0.77	0.78	<b>1MJ6 070-4CA□□</b>			20	
0.37	0.43	71 M	1375	2.5	64	0.74	1.13	<b>1MJ6 073-4CB□□</b>			21	
0.55	0.63	80 M	1395	3.7	71	0.79	1.42	<b>1MJ6 080-4CA□□</b>			24	
0.75	0.86	80 M	1395	5.1	73	0.79	1.88	<b>1MJ6 083-4CA□□</b>			26	
1.1	1.3	90 L	1410	7.5	73	0.80	2.7	<b>1MJ6 096-4CA□□</b>			32	
1.5	1.75	90 L	1420	10	77	0.8	3.5	<b>1MJ6 097-4CA□□</b>			35	
2.2	2.55	100 L	1420	15	78	0.8	5.1	<b>1MJ6 106-4CA□□</b>			44	
3	3.45	100 L	1415	20	80	0.82	6.6	<b>1MJ6 107-4CA□□</b>			47	
4	4.6	112 M	1435	27	83	0.82	8	<b>1MJ6 113-4CA□□</b>			58	
5.5	6.3	132 S	1450	36	86	0.83	11.1	<b>1MJ6 130-4CA□□</b>			76	
7.5	8.6	132 M	1450	49	86	0.84	15	<b>1MJ6 133-4CA□□</b>			85	
11	12.6	160 M	1455	72	87	0.85	21.5	<b>1MJ6 163-4CA□□</b>			128	
15	17.3	160 L	1455	98	89	0.85	28.5	<b>1MJ6 166-4CA□□</b>			158	
18.5	21.3	180 M	1460	121	90.5	0.84	35	<b>1MJ6 183-4CA□□</b>			175	
22	25.3	180 L	1460	144	91.2	0.85	41	<b>1MJ6 186-4CA□□</b>			189	
30	34.5	200 L	1465	196	91.8	0.86	55	<b>1MJ6 207-4CA□□</b>			247	
37	42.5	225 S	1475	240	93	0.86	67 <sup>1)</sup>	<b>1MJ7 220-4CA□□</b>			325	
45	52	225 M	1475	292	93.4	0.87	80 <sup>1)</sup>	<b>1MJ7 223-4CA□□</b>			355	
55	63	250 M	1480	355	94	0.87	97 <sup>1)</sup>	<b>1MJ7 253-4CA□□</b>			465	
75	86	280 S	1485	482	94.7	0.86	132 <sup>1)</sup>	<b>1MJ7 280-4CA□□</b>			630	
90	104	280 M	1485	579	95	0.86	160 <sup>1)</sup>	<b>1MJ7 283-4CA□□</b>			680	
110	127	315 S	1486	707	94.8	0.86	194 <sup>1)</sup>	<b>1MJ7 310-4CA□□</b>			870	
132	152	315 M	1486	848	95.5	0.86	232 <sup>1)</sup>	<b>1MJ7 313-4CA□□</b>			950	

### Order No. supplements

Motor type	Penultimate position: Voltage code				Final position: Type of construction code							
	50 Hz				Without flange	With flange		With standard flange				With special flange
	230 VΔ/400 VY	400 VΔ/690 VY	500 VY	500 VΔ	IM B3/6/7/8, IM V6 <sup>2) 5)</sup>	IM B5, IM V3 <sup>2) 4)</sup>	IM V1 with protective cover <sup>2) 4) 5)</sup>	IM B35	IM B14, IM V19 <sup>2)</sup>	IM B34	IM B14, IM V19 <sup>2)</sup>	
1	6	3	5	0	1	4	6	2	7	3		
<b>1MJ6 07</b> . . . . . □□	○	○	○	–	□	✓	✓	✓	✓	✓	✓	
<b>1MJ6 08</b> . . . . . □□	○	○	○	–	□	✓	✓	✓	✓	✓	✓	
<b>1MJ6 09</b> . . . . . □□	○	○	○	–	□	✓	✓	✓	✓	✓	–	
<b>1MJ6 10</b> . . . . . □□	○	○	○	○	□	✓	✓	✓	–	–	–	
<b>1MJ6 11</b> . . . . . □□	○	○	○	○	□	✓	✓	✓	–	–	–	
<b>1MJ6 13</b> . . . . . □□	○	○	○	○	□	✓	✓	✓	–	–	–	
<b>1MJ6 16</b> . . . . . □□	○	○	○	○	□	✓	✓	✓	–	–	–	
<b>1MJ6 18</b> . . . . . □□	○	○	○	○	□	✓ <sup>6)</sup>	✓	✓	–	–	–	
<b>1MJ6 20</b> . . . . . □□	○	○	○	○	□	✓ <sup>6)</sup>	✓	✓	–	–	–	
<b>1MJ7 22</b> . . . . . □□	○	○	○	○	□	✓ <sup>6)</sup>	✓	✓	–	–	–	
<b>1MJ7 25</b> . . . . . □□	○	○	○	○	□	✓ <sup>6)</sup>	✓	✓	–	–	–	
<b>1MJ7 28</b> . . . . . □□	○	○	○	○	□	✓ <sup>6)</sup>	✓	✓	–	–	–	
<b>1MJ7 31</b> . . . . . □□	○	○	○	○	□	✓ <sup>6)</sup>	✓	✓	–	–	–	

- Standard version
- Without additional charge
- ✓ With additional charge
- Not possible

Order other voltages with voltage code **9** in the penultimate position and the corresponding order code (see "Special versions" in the "Selection and ordering data" under "Voltages").

Order other types of construction with type of construction code **9** in the final position and the corresponding order code (see "Special versions" in the "Selection and ordering data" under "Types of construction").

For footnotes, see Page 4/37.



# IEC Squirrel-Cage Motors

## Explosion-proof motors

Self-ventilated in Zone 1 with type of protection "de"  
Cast-iron series 1MJ6 and 1MJ7

### Selection and ordering data (continued)

Order No.	Locked-rotor torque with direct starting torque	Locked-rotor current as multiple of rated current	Breakdown torque	Torque class	Moment of inertia	Noise at rated output	
	$T_{LR}/T_{rated}$	$I_{LR}/I_{rated}$	$T_B/T_{rated}$	CL	$J$ kgm <sup>2</sup>	Measuring surface sound pressure level at 50 Hz $L_{pFA}$ dB(A)	Sound pressure level at 50 Hz $L_{WA}$ dB(A)
<b>4-pole, 1500 rpm at 50 Hz, 1800 rpm at 60 Hz, temperature class 155 (F), IP55 degree of protection, temperature classes T1 to T4</b>							
<b>1MJ6 070-4CB□□</b>	1.8	3.2	1.8	13	0.0006	44	55
<b>1MJ6 073-4CB□□</b>	2	3.6	2	13	0.0008	44	55
<b>1MJ6 080-4CA□□</b>	2.3	4.7	2.4	16	0.0015	47	58
<b>1MJ6 083-4CA□□</b>	2.5	5	2.6	16	0.0018	47	58
<b>1MJ6 096-4CA□□</b>	2.1	4.9	2.5	16	0.0028	48	60
<b>1MJ6 097-4CA□□</b>	2.2	5.8	2.6	16	0.0035	48	60
<b>1MJ6 106-4CA□□</b>	2.2	6	2.6	16	0.0048	53	65
<b>1MJ6 107-4CA□□</b>	2.7	6.4	3	16	0.0058	53	65
<b>1MJ6 113-4CA□□</b>	2.8	7.2	3	16	0.01	53	65
<b>1MJ6 130-4CA□□</b>	2.4	6.9	3.3	16	0.01	62	74
<b>1MJ6 133-4CA□□</b>	2.7	7.7	3.3	16	0.02	62	74
<b>1MJ6 163-4CA□□</b>	2.4	6.6	2.9	16	0.04	66	78
<b>1MJ6 166-4CA□□</b>	2.8	7.4	3.2	16	0.05	66	78
<b>1MJ6 183-4CA□□</b>	2.3	7.1	3	16	0.13	63	76
<b>1MJ6 186-4CA□□</b>	2.3	7.1	3	16	0.15	63	76
<b>1MJ6 207-4CA□□</b>	2.6	7.4	3.2	16	0.24	65	78
<b>1MJ7 220-4CA□□</b>	2.5	7	3.1	16	0.44	65	78
<b>1MJ7 223-4CA□□</b>	2.6	7	3.2	16	0.52	65	78
<b>1MJ7 253-4CA□□</b>	2.6	6.7	2.5	16	0.79	65	79
<b>1MJ7 280-4CA□□</b>	2.5	6.7	2.7	16	1.4	67	81
<b>1MJ7 283-4CA□□</b>	2.5	6.8	2.8	16	1.6	67	81
<b>1MJ7 310-4CA□□</b>	2.5	6.7	2.7	16	2.2	69	83
<b>1MJ7 313-4CA□□</b>	2.7	7.2	3	16	2.7	69	83

The 1MJ6/1MJ7 motors can also be ordered for use with type of protection Ex d/de (Zone 1)/dust-Ex Zone 21, as well as for Zone 22 for conducting dust:

Mains-fed operation – order code **M76**

Converter-fed operation with derating – order code **M77**

See "Special versions" in the "Selection and ordering data" under "Options".

Other versions up to 1400 kW as 4-pole motors as DN series with Order No. 1PS4 (Ex de IIB), 1PS5 (Ex de IIC) available; also higher outputs and other numbers of poles possible.

Place request with:

Loher GmbH (a Siemens company)

Hans-Loher-Str. 32

94099 Ruhstorf/Rott

<http://www.loher.com>

- For connection to 230 V, parallel feeders are necessary (see the "Introduction" section, "Connection, circuit and connection box").
- The following applies for explosion-proof motors: In the case of the types of construction with shaft extension down, the version "with protective cover" is required. For types of construction with shaft extension pointing upwards, a suitable cover must be implemented to prevent small parts from falling into the fan cover (see the standard IEC/EN 60079-0). The cover must not block the cooling air-flow.
- If motors 1MJ6 183-... to 1MJ7 313-... (motor series 1MJ6 frame size 180 M and above to 1MJ7 frame size 315 M) in types of construction with feet IM B6, IM B7 or IM V6 are fixed to the wall, it is recommended that the motor feet are supported.
- 1MJ7 220-... to 1MJ7 313-... motors (motor series 1MJ7 frame sizes 225 S to 315 M) are supplied with two screw-in eyebolts in accordance with IM B5, whereby one can be relocated in accordance with IM V1 or IM V3. It is important to note that stress must not be applied perpendicular to the ring plane.
- The "Second shaft extension" option, order code **K16** is not possible.
- Type of construction IM V3 is only possible using type of construction code **9** and order code **M1G**.

# IEC Squirrel-Cage Motors

## Explosion-proof motors

Self-ventilated in Zone 1 with type of protection "de"  
Cast-iron series 1MJ6 and 1MJ7

### Selection and ordering data (continued)

Rated output at		Frame size	Operating values at rated output					Power factor at 50 Hz	Rated current at 400 V, 50 Hz	Order No. For Order No. supplements for voltage and type of construction, see table below	Price	Weight IM B3 type of construction approx. m kg
50 Hz	60 Hz		Rated speed at 50 Hz	Rated torque at 50 Hz	Efficiency at 50 Hz <sup>1)</sup>							
$P_{\text{rated}}$ kW	$P_{\text{rated}}$ kW	FS	$n_{\text{rated}}$ rpm	$T_{\text{rated}}$ Nm	$\eta_{\text{rated}}$ %	$\cos\phi_{\text{rated}}$	$I_{\text{rated}}$ A					
<b>6-pole, 1000 rpm at 50 Hz, 1200 rpm at 60 Hz, temperature class 155 (F), IP55 degree of protection temperature classes T1 to T4</b>												
0.25	0.29	71 M	870	2.7	63	0.7	0.82	<b>1MJ6 073-6CA□□</b>			16	
0.37	0.43	80 M	910	3.9	64	0.71	1.18	<b>1MJ6 080-6CA□□</b>			35	
0.55	0.63	80 M	900	5.8	64	0.74	1.67	<b>1MJ6 083-6CA□□</b>			22.5	
0.75	0.86	90 L	910	8	68	0.74	2.15	<b>1MJ6 096-6CA□□</b>			32	
1.1	1.3	90 L	905	12	72	0.75	2.95	<b>1MJ6 097-6CA□□</b>			32	
1.5	1.75	100 L	930	15	75	0.73	4	<b>1MJ6 106-6CA□□</b>			39	
2.2	2.55	112 M	945	22	76	0.76	5.5	<b>1MJ6 113-6CA□□</b>			52	
3	3.45	132 S	945	30	78	0.75	7.4	<b>1MJ6 130-6CA□□</b>			78	
4	4.6	132 M	945	40	79	0.76	9.6	<b>1MJ6 133-6CA□□</b>			85	
5.5	6.3	132 M	950	55	83	0.76	12.6	<b>1MJ6 134-6CA□□</b>			92	
7.5	8.6	160 M	960	75	86	0.72	17.5	<b>1MJ6 163-6CA□□</b>			134	
11	12.6	160 L	960	109	87	0.74	24.5	<b>1MJ6 166-6CA□□</b>			167	
15	18	180 L	970	148	89	0.83	29.5	<b>1MJ6 186-6CA□□</b>			190	
18.5	22	200 L	975	181	90.2	0.82	36	<b>1MJ6 206-6CA□□</b>			240	
22	26.5	200 L	975	215	90.8	0.83	42.5	<b>1MJ6 207-6CA□□</b>			255	
30	36	225 M	978	293	92	0.84	56	<b>1MJ7 223-6CA□□</b>			330	
37	44.5	250 M	980	361	92.4	0.84	69	<b>1MJ7 253-6CA□□</b>			440	
45	54	280 S	982	438	93	0.86	81	<b>1MJ7 280-6CA□□</b>			560	
55	66	280 M	984	534	93.6	0.86	99 <sup>1)</sup>	<b>1MJ7 283-6CA□□</b>			600	
75	90	315 S	988	725	93.8	0.85	136	<b>1MJ7 310-6CA□□</b>			810	
90	108	315 M	988	870	94.2	0.85	162 <sup>1)</sup>	<b>1MJ7 313-6CA□□</b>			870	

### Order No. supplements

Motor type	Penultimate position: Voltage code				Final position: Type of construction code								
	50 Hz				Without flange		With flange		With standard flange				With special flange
	230 VΔ/400 VY	400 VΔ/690 VY	500 VY	500 VΔ	IM B3/6/7/8, IM V6 <sup>2) 3)</sup>	IM B5, IM V3 <sup>2) 4)</sup>	IM V1 with protective cover <sup>2) 4) 5)</sup>	IM B35	IM B14, IM V19 <sup>2)</sup>	IM B34	IM B14, IM V19 <sup>2)</sup>	IM B14, IM V19 <sup>2)</sup>	
	1	6	3	5	0	1	4	6	2	7	3		
<b>1MJ6 07</b> . . . . . □□	○	○	○	–	□	✓	✓	✓	✓	✓	✓	✓	
<b>1MJ6 08</b> . . . . . □□	○	○	○	–	□	✓	✓	✓	✓	✓	✓	✓	
<b>1MJ6 09</b> . . . . . □□	○	○	○	–	□	✓	✓	✓	✓	✓	✓	–	
<b>1MJ6 10</b> . . . . . □□	○	○	○	○	□	✓	✓	✓	–	–	–	–	
<b>1MJ6 11</b> . . . . . □□	○	○	○	○	□	✓	✓	✓	–	–	–	–	
<b>1MJ6 13</b> . . . . . □□	○	○	○	○	□	✓	✓	✓	–	–	–	–	
<b>1MJ6 16</b> . . . . . □□	○	○	○	○	□	✓	✓	✓	–	–	–	–	
<b>1MJ6 18</b> . . . . . □□	○	○	○	○	□	✓ <sup>6)</sup>	✓	✓	–	–	–	–	
<b>1MJ6 20</b> . . . . . □□	○	○	○	○	□	✓ <sup>6)</sup>	✓	✓	–	–	–	–	
<b>1MJ7 22</b> . . . . . □□	○	○	○	○	□	✓ <sup>6)</sup>	✓	✓	–	–	–	–	
<b>1MJ7 25</b> . . . . . □□	○	○	○	○	□	✓ <sup>6)</sup>	✓	✓	–	–	–	–	
<b>1MJ7 28</b> . . . . . □□	○	○	○	○	□	✓ <sup>6)</sup>	✓	✓	–	–	–	–	
<b>1MJ7 31</b> . . . . . □□	○	○	○	○	□	✓ <sup>6)</sup>	✓	✓	–	–	–	–	

- Standard version
- Without additional charge
- ✓ With additional charge
- Not possible

Order other voltages with voltage code **9** in the penultimate position and the corresponding order code (see "Special versions" in the "Selection and ordering data" under "Voltages").

Order other types of construction with type of construction code **9** in the final position and the corresponding order code (see "Special versions" in the "Selection and ordering data" under "Types of construction").

For footnotes, see Page 4/39.

# IEC Squirrel-Cage Motors

## Explosion-proof motors

Self-ventilated in Zone 1 with type of protection "de"  
Cast-iron series 1MJ6 and 1MJ7

### Selection and ordering data (continued)

Order No.	Locked-rotor torque with direct starting torque	Locked-rotor current as multiple of rated current	Breakdown torque	Torque class	Moment of inertia	Noise at rated output	
	$T_{LR}/T_{rated}$	$I_{LR}/I_{rated}$	$T_B/T_{rated}$	CL	$J$ kgm <sup>2</sup>	Measuring surface sound pressure level at 50 Hz $L_{pFA}$ dB(A)	Sound pressure level at 50 Hz $L_{WA}$ dB(A)
<b>6-pole, 1000 rpm at 50 Hz, 1200 rpm at 60 Hz, temperature class 155 (F), IP55 degree of protection temperature classes T1 to T4</b>							
<b>1MJ6 073-6CA□□</b>	2.2	3.1	2.2	16	0.0009	39	50
<b>1MJ6 080-6CA□□</b>	1.9	3.3	2	16	0.0015	40	51
<b>1MJ6 083-6CA□□</b>	2	3.5	2.1	16	0.0018	40	51
<b>1MJ6 096-6CA□□</b>	2.2	3.9	2.3	16	0.0028	43	55
<b>1MJ6 097-6CA□□</b>	2.4	4.3	2.4	16	0.0035	43	55
<b>1MJ6 106-6CA□□</b>	2.3	4.5	2.5	16	0.0063	47	59
<b>1MJ6 113-6CA□□</b>	2.2	4.8	2.5	16	0.01	52	64
<b>1MJ6 130-6CA□□</b>	2	4.8	2.2	16	0.01	63	75
<b>1MJ6 133-6CA□□</b>	2	5	2.4	16	0.01	63	75
<b>1MJ6 134-6CA□□</b>	2.2	5.4	2.5	16	0.02	63	75
<b>1MJ6 163-6CA□□</b>	2.1	5.1	2.5	16	0.04	66	78
<b>1MJ6 166-6CA□□</b>	2.3	5.5	2.5	16	0.04	66	78
<b>1MJ6 186-6CA□□</b>	2.6	6.3	2.4	16	0.2	66	78
<b>1MJ6 206-6CA□□</b>	2.6	6.3	2.3	16	0.29	66	78
<b>1MJ6 207-6CA□□</b>	2.5	5.7	2.3	16	0.33	66	78
<b>1MJ7 223-6CA□□</b>	2.6	5.7	2.2	16	0.57	66	78
<b>1MJ7 253-6CA□□</b>	2.6	6	2.1	16	0.89	60	74
<b>1MJ7 280-6CA□□</b>	2.4	6	2.3	16	1.3	60	74
<b>1MJ7 283-6CA□□</b>	2.5	6.2	2.4	16	1.5	60	74
<b>1MJ7 310-6CA□□</b>	2.4	6.2	2.5	16	2.4	63	77
<b>1MJ7 313-6CA□□</b>	2.4	6.2	2.5	16	2.9	63	77

The 1MJ6/1MJ7 motors can also be ordered for use with type of protection Ex d/de (Zone 1)/dust-Ex Zone 21, as well as for Zone 22 for conducting dust:

Mains-fed operation – order code **M76**

Converter-fed operation with derating – order code **M77**

See "Special versions" in the "Selection and ordering data" under "Options".

Other versions up to 1600 kW as 6-pole motors as DN series with Order No. 1PS4 (Ex de IIB), 1PS5 (Ex de IIC) available; also higher outputs and other numbers of poles possible.

Place request with:

Loher GmbH (a Siemens company)

Hans-Loher-Str. 32  
94099 Ruhstorf/Rott

<http://www.loher.com>

- For connection to 230 V, parallel feeders are necessary (see the "Introduction" section, "Connection, circuit and connection box").
- The following applies for explosion-proof motors: In the case of the types of construction with shaft extension down, the version "with protective cover" is required. For types of construction with shaft extension pointing upwards, a suitable cover must be implemented to prevent small parts from falling into the fan cover (see the standard IEC/EN 60079-0). The cover must not block the cooling air-flow.
- If motors 1MJ6 183-... to 1MJ7 313-... (motor series 1MJ6 frame size 180 M and above to 1MJ7 frame size 315 M) in types of construction with feet IM B6, IM B7 or IM V6 are fixed to the wall, it is recommended that the motor feet are supported.
- 1MJ7 220-... to 1MJ7 313-... motors (motor series 1MJ7 frame sizes 225 S to 315 M) are supplied with two screw-in eyebolts in accordance with IM B5, whereby one can be relocated in accordance with IM V1 or IM V3. It is important to note that stress must not be applied perpendicular to the ring plane.
- The "Second shaft extension" option, order code **K16** is not possible.
- Type of construction IM V3 is only possible using type of construction code **9** and order code **M1G**.

# IEC Squirrel-Cage Motors

## Explosion-proof motors

Self-ventilated in Zone 1 with type of protection "de"  
Cast-iron series 1MJ6 and 1MJ7

### Selection and ordering data (continued)

Rated output at		Frame size	Operating values at rated output					Rated current at 400 V, 50 Hz	Order No. For Order No. supplements for voltage and type of construction, see table below	Price	Weight IM B3 type of construction approx. m kg
50 Hz	60 Hz		Rated speed at 50 Hz	Rated torque at 50 Hz	Efficiency at 50 Hz	Power factor at 50 Hz	Rated torque at 50 Hz				
$P_{rated}$ kW	$P_{rated}$ kW	FS	$n_{rated}$ rpm	$T_{rated}$ Nm	$\eta_{rated}$ %	$\cos\phi_{rated}$	$I_{rated}$ A				
<b>8-pole, 750 rpm at 50 Hz, 900 rpm at 60 Hz, temperature class 155 (F), IP55 degree of protection, temperature classes T1 to T4</b>											
0.37	0.43	90 L	655	5.3	61	0.76	1.16	<b>1MJ6 096-8CB□□</b>		27.5	
0.55	0.63	90 L	655	7.9	65	0.76	1.62	<b>1MJ6 097-8CB□□</b>		29.5	
0.75	0.86	100 L	685	10	65	0.72	2.3	<b>1MJ6 106-8CB□□</b>		40	
1.1	1.3	100 L	685	16	74	0.74	2.9	<b>1MJ6 107-8CB□□</b>		48	
1.5	1.75	112 M	700	21	74	0.73	4	<b>1MJ6 113-8CB□□</b>		52	
2.2	2.55	132 S	695	30	74	0.72	6	<b>1MJ6 130-8CB□□</b>		78	
3	3.45	132 M	700	40	76	0.72	7.9	<b>1MJ6 133-8CB□□</b>		85	
4	4.6	160 M	715	54	81	0.72	9.9	<b>1MJ6 163-8CB□□</b>		119	
5.5	6.3	160 M	710	74	83	0.72	13.3	<b>1MJ6 164-8CB□□</b>		134	
7.5	8.6	160 L	715	100	84	0.72	17.9	<b>1MJ6 166-8CB□□</b>		159	
11	13.2	180 L	725	145	87	0.7	26	<b>1MJ6 186-8CB□□</b>		191	
15	18	200 L	725	198	87.5	0.78	32	<b>1MJ6 207-8CB□□</b>		263	
18.5	22	225 S	725	244	88.6	0.8	37.5	<b>1MJ7 220-8CB□□</b>		325	
22	26.5	225 M	725	290	90.1	0.81	43.5	<b>1MJ7 223-8CB□□</b>		350	
30	36	250 M	730	392	91.6	0.81	58	<b>1MJ7 253-8CB□□</b>		465	
37	44.5	280 S	732	483	92.7	0.82	70	<b>1MJ7 280-8CB□□</b>		570	
45	54	280 M	734	585	92.8	0.83	84	<b>1MJ7 283-8CB□□</b>		620	
55	66	315 S	738	712	93.1	0.82	104	<b>1MJ7 310-8CB□□</b>		780	
75	90	315 M	738	970	93.6	0.82	140	<b>1MJ7 313-8CB□□</b>		890	

### Order No. supplements

Motor type	Penultimate position: Voltage code				Final position: Type of construction code						
	50 Hz				Without flange	With flange			With standard flange		With special flange
	230 VΔ/400 VY	400 VΔ/690 VY	500 VY	500 VΔ	IM B3(6/7/8, IM V6 <sup>1)2)</sup>	IM B5, <sup>1)3)</sup> IM V3 <sup>3)</sup>	IM V1 with protective cover <sup>1)3)4)</sup>	IM B35	IM B14, <sup>1)</sup> IM V19 <sup>1)</sup>	IM B34	IM B14 IM V19 <sup>1)</sup>
<b>1</b>	<b>6</b>	<b>3</b>	<b>5</b>	<b>0</b>	<b>1</b>	<b>4</b>	<b>6</b>	<b>2</b>	<b>7</b>	<b>3</b>	
<b>1MJ6 07 . . . . □□</b>	○	○	○	–	□	✓	✓	✓	✓	✓	✓
<b>1MJ6 08 . . . . □□</b>	○	○	○	–	□	✓	✓	✓	✓	✓	✓
<b>1MJ6 09 . . . . □□</b>	○	○	○	–	□	✓	✓	✓	✓	✓	–
<b>1MJ6 10 . . . . □□</b>	○	○	○	○	□	✓	✓	✓	–	–	–
<b>1MJ6 11 . . . . □□</b>	○	○	○	○	□	✓	✓	✓	–	–	–
<b>1MJ6 13 . . . . □□</b>	○	○	○	○	□	✓	✓	✓	–	–	–
<b>1MJ6 16 . . . . □□</b>	○	○	○	○	□	✓	✓	✓	–	–	–
<b>1MJ6 18 . . . . □□</b>	○	○	○	○	□	✓ <sup>5)</sup>	✓	✓	–	–	–
<b>1MJ6 20 . . . . □□</b>	○	○	○	○	□	✓ <sup>5)</sup>	✓	✓	–	–	–
<b>1MJ7 22 . . . . □□</b>	○	○	○	○	□	✓ <sup>5)</sup>	✓	✓	–	–	–
<b>1MJ7 25 . . . . □□</b>	○	○	○	○	□	✓ <sup>5)</sup>	✓	✓	–	–	–
<b>1MJ7 28 . . . . □□</b>	○	○	○	○	□	✓ <sup>5)</sup>	✓	✓	–	–	–
<b>1MJ7 31 . . . . □□</b>	○	○	○	○	□	✓ <sup>5)</sup>	✓	✓	–	–	–

- Standard version
- Without additional charge
- ✓ With additional charge
- Not possible

Order other voltages with voltage code **9** in the penultimate position and the corresponding order code (see "Special versions" in the "Selection and ordering data" under "Voltages").

Order other types of construction with type of construction code **9** in the final position and the corresponding order code (see "Special versions" in the "Selection and ordering data" under "Types of construction").

For footnotes, see Page 4/41.

# IEC Squirrel-Cage Motors

## Explosion-proof motors

Self-ventilated in Zone 1 with type of protection "de"  
Cast-iron series 1MJ6 and 1MJ7

### Selection and ordering data (continued)

Order No.	Locked-rotor torque with direct starting torque	Locked-rotor current as multiple of rated current	Breakdown torque	Torque class	Moment of inertia	Noise at rated output	
	$T_{LR}/T_{rated}$	$I_{LR}/I_{rated}$	$T_B/T_{rated}$	CL	$J$ kgm <sup>2</sup>	Measuring surface sound pressure level at 50 Hz $L_{pFA}$ dB(A)	Sound pressure level at 50 Hz $L_{WA}$ dB(A)
<b>8-pole, 750 rpm at 50 Hz, 900 rpm at 60 Hz, temperature class 155 (F), IP55 degree of protection, temperature classes T1 to T4</b>							
<b>1MJ6 096-8CB□□</b>	1.4	2.8	1.7	13	0.0025	41	53
<b>1MJ6 097-8CB□□</b>	1.5	2.9	1.7	13	0.0035	41	53
<b>1MJ6 106-8CB□□</b>	1.6	3.5	1.8	13	0.0053	45	57
<b>1MJ6 107-8CB□□</b>	1.8	3.9	2	13	0.007	45	57
<b>1MJ6 113-8CB□□</b>	1.8	4.4	2	13	0.01	49	61
<b>1MJ6 130-8CB□□</b>	1.7	4.2	2.1	13	0.01	53	65
<b>1MJ6 133-8CB□□</b>	1.9	4.4	2.2	13	0.01	53	65
<b>1MJ6 163-8CB□□</b>	2.1	4.8	2.3	13	0.03	63	75
<b>1MJ6 164-8CB□□</b>	2.3	5.1	2.5	13	0.04	63	75
<b>1MJ6 166-8CB□□</b>	2.6	5.8	2.8	13	0.06	63	75
<b>1MJ6 186-8CB□□</b>	2	5	2.2	13	0.21	60	73
<b>1MJ6 207-8CB□□</b>	2.1	5	2.2	13	0.37	58	71
<b>1MJ7 220-8CB□□</b>	2.1	5	2.2	13	0.58	58	71
<b>1MJ7 223-8CB□□</b>	2.1	5	2.2	13	0.66	58	71
<b>1MJ7 253-8CB□□</b>	2.1	5	2.1	13	1.1	57	71
<b>1MJ7 280-8CB□□</b>	2.2	5.5	2.2	13	1.4	58	72
<b>1MJ7 283-8CB□□</b>	2.2	5.5	2.2	13	1.6	58	72
<b>1MJ7 310-8CB□□</b>	2.2	6	2.4	13	2.3	62	76
<b>1MJ7 313-8CB□□</b>	2.3	6.2	2.5	13	3	62	76

The 1MJ6/1MJ7 motors can also be ordered for use with type of protection Ex d/de (Zone 1)/dust-Ex Zone 21, as well as for Zone 22 for conducting dust:

Mains-fed operation – order code **M76**

Converter-fed operation with derating – order code **M77**

See "Special versions" in the "Selection and ordering data" under "Options".

Other versions up to 1350 kW as 8-pole motors as DN series with Order No. 1PS4 (Ex de IIB), 1PS5 (Ex de IIC) available; also higher outputs and other numbers of poles possible.

Place request with:

Loher GmbH (a Siemens company)  
Hans-Loher-Str. 32  
94099 Ruhstorf/Rott

<http://www.loher.com>

- The following applies for explosion-proof motors: In the case of the types of construction with shaft extension down, the version "with protective cover" is required. For types of construction with shaft extension pointing upwards, a suitable cover must be implemented to prevent small parts from falling into the fan cover (see the standard IEC/EN 60079-0). The cover must not block the cooling air-flow.
- If motors 1MJ6 183-... to 1MJ7 313-... (motor series 1MJ6 frame size 180 M and above to 1MJ7 frame size 315 M) in types of construction with feet IM B6, IM B7 or IM V6 are fixed to the wall, it is recommended that the motor feet are supported.
- 1MJ7 220-... to 1MJ7 313-... motors (motor series 1MJ7 frame sizes 225 S to 315 M) are supplied with two screw-in eyebolts in accordance with IM B5, whereby one can be relocated in accordance with IM V1 or IM V3. It is important to note that stress must not be applied perpendicular to the ring plane.
- The "Second shaft extension" option, order code **K16** is not possible.
- Type of construction IM V3 is only possible using type of construction code **9** and order code **M1G**.

# IEC Squirrel-Cage Motors

## Explosion-proof motors

Self-ventilated, in Zones 2, 21, 22 with type of prot. "n" or prot. against dust explosions – Aluminum series 1LA7/1LA5

### Selection and ordering data

Rated output at		Frame size	Operating values at rated output						Order No.	Price	Weight IM B3 type of construction approx. m kg
50 Hz	60 Hz		Rated speed at 50 Hz	Rated torque at 50 Hz	Efficiency at 50 Hz 4/4-load	Efficiency at 50 Hz 3/4-load	Power factor at 50 Hz 4/4-load	Rated current at 400 V, 50 Hz			
$P_{rated}$ kW	$P_{rated}$ kW	FS	$n_{rated}$ rpm	$T_{rated}$ Nm	$\eta_{rated}$ %	$\eta_{rated}$ %	$\cos\phi_{rated}$	$I_{rated}$ A	For Order No. supplements for voltage, type of construction and explosion protection zones according to ATEX, see tables below		
<b>2-pole, 3000 rpm at 50 Hz, 3600 rpm at 60 Hz, temperature class 155 (F), IP55 degree of protection</b>											
0.09	0.11	56 M	2830	0.3	63	62	0.81	0.26	<b>1LA7 050-2AA□□</b>	3	
0.12	0.14	56 M	2800	0.41	65	64	0.83	0.32	<b>1LA7 053-2AA□□</b>	3	
0.18	0.21	63 M	2820	0.61	64	63	0.79	0.51	<b>1LA7 060-2AA□□</b>	3.5	
0.25	0.29	63 M	2830	0.84	65	65	0.80	0.69	<b>1LA7 063-2AA□□</b>	4.1	
0.37	0.43	71 M	2740	1.3	66	65	0.82	1	<b>1LA7 070-2AA□□</b>	5	
0.55	0.63	71 M	2800	1.9	71	70	0.82	1.36	<b>1LA7 073-2AA□□</b>	6	
0.75	0.86	80 M	2855	2.5	73	72	0.86	1.73	<b>1LA7 080-2AA□□</b>	9	
1.1	1.3	80 M	2845	3.7	77	77	0.87	2.4	<b>1LA7 083-2AA□□</b>	11	
1.5	1.75	90 S	2860	5	79	80	0.85	3.25	<b>1LA7 090-2AA□□</b>	12.9	
2.2	2.55	90 L	2880	7.3	82	82	0.85	4.55	<b>1LA7 096-2AA□□</b>	15.7	
3	3.45	100 L	2890	9.9	84	84	0.85	6.1	<b>1LA7 106-2AA□□</b>	22	
4	4.6	112 M	2905	13	86	86	0.86	7.8	<b>1LA7 113-2AA□□</b>	29	
5.5	6.3	132 S	2925	18	86.5	86.5	0.89	10.4	<b>1LA7 130-2AA□□</b>	39	
7.5	8.6	132 S	2930	24	88	88	0.89	13.8	<b>1LA7 131-2AA□□</b>	48	
11	12.6	160 M	2940	36	89.5	89.5	0.88	20	<b>1LA7 163-2AA□□</b>	68	
15	17.3	160 M	2930	49	90	90.2	0.9	26.5	<b>1LA7 164-2AA□□</b>	77	
18.5	21.3	160 L	2940	60	91	91.2	0.91	32	<b>1LA7 166-2AA□□</b>	86	
22	24.5	180 M	2940	71	91.7	91.7	0.88	39.5 <sup>1)</sup>	<b>1LA5 183-2AA□□</b>	113	
30	33.5	200 L	2945	97	92.3	92.3	0.89	53	<b>1LA5 206-2AA□□</b>	159	
37	41.5	200 L	2945	120	92.8	92.8	0.89	65 <sup>1)</sup>	<b>1LA5 207-2AA□□</b>	179	
45	51	225 M	2960	145	93.6	93.6	0.89	78 <sup>1)</sup>	<b>1LA5 223-2AA□□</b>	209	

### Special versions according to ATEX

Motor type	Zone 2		VIK (includes Zone 2) <sup>2)</sup>		Zone 21		Zone 22	
	Mains-fed operation	Converter-fed operation (FC)	Mains-fed operation	Converter-fed operation (FC)	Mains-fed operation	Converter-fed operation (FC)	Mains-fed operation	Converter-fed operation (FC)
Frame size	Order code M72	Order code M73	Order code K30	On request	Order code M34	Order code M38	Order code M35	Order code M39
<b>1LA7</b>	56	–	–	–	✓	✓	✓	✓
	63	✓	✓	✓	✓	✓	✓	✓
	71	✓	✓	✓	✓	✓	✓	✓
	80	✓	✓	✓	✓	✓	✓	✓
	90	✓	✓	✓	✓	✓	✓	✓
	100	✓	✓	✓	✓	✓	✓	✓
	112	✓	✓	✓	✓	✓	✓	✓
	132	✓	✓	✓	✓	✓	✓	✓
<b>1LA5</b>	160	✓	✓	✓	✓	✓	✓	✓
	180	–	–	–	–	✓	✓	✓
	200	–	–	–	–	✓	✓	✓
	225	–	–	–	–	✓	✓	✓

- ✓ With additional charge  
– Not possible

The motors can also be ordered in design for Zones 2 and 22 for non-conducting dust (IP55):

Mains-fed operation – order code **M74**

Converter-fed operation with derating – order code **M75**

See "Special versions" in the "Selection and ordering data" under "Options".

<sup>1)</sup> For connection to 230 V, parallel feeders are necessary (see the "Introduction" section, "Connection, circuit and connection box").

<sup>2)</sup> If the marking Ex nA II is required in addition to VIK on the rating plate, this must be ordered using order code **C27**. The VIK version is not possible in combination with Zone 21 and 22.

# IEC Squirrel-Cage Motors

## Explosion-proof motors

Self-ventilated, in Zones 2, 21, 22 with type of prot. "n" or prot. against dust explosions – Aluminum series 1LA7/1LA5

### Selection and ordering data (continued)

Order No.	Locked-rotor torque with direct starting torque	Locked-rotor current as multiple of rated current	Breakdown torque	Torque class	Moment of inertia	Noise at rated output	
	$T_{LR}/T_{rated}$	$I_{LR}/I_{rated}$	$T_B/T_{rated}$	CL	$J$ kgm <sup>2</sup>	Measuring surface sound pressure level at 50 Hz $L_{pFA}$ dB(A)	Sound pressure level at 50 Hz $L_{WA}$ dB(A)
<b>2-pole, 3000 rpm at 50 Hz, 3600 rpm at 60 Hz, temperature class 155 (F), IP55 degree of protection</b>							
1LA7 050-2AA□□	2	3.7	2.3	16	0.00015	41	52
1LA7 053-2AA□□	2.1	3.7	2.4	16	0.00015	41	52
1LA7 060-2AA□□	2	3.7	2.2	16	0.00018	49	60
1LA7 063-2AA□□	2	4	2.2	16	0.00022	49	60
1LA7 070-2AA□□	2.3	3.5	2.3	16	0.00029	52	63
1LA7 073-2AA□□	2.5	4.3	2.6	16	0.00041	52	63
1LA7 080-2AA□□	2.3	5.6	2.4	16	0.00079	56	67
1LA7 083-2AA□□	2.6	6.1	2.7	16	0.001	56	67
1LA7 090-2AA□□	2.4	5.5	2.7	16	0.0014	62	74
1LA7 096-2AA□□	2.8	6.3	3.1	16	0.0018	62	74
1LA7 106-2AA□□	2.8	6.8	3	16	0.0035	62	74
1LA7 113-2AA□□	2.6	7.2	2.9	16	0.0059	63	75
1LA7 130-2AA□□	2	5.9	2.8	16	0.015	68	80
1LA7 131-2AA□□	2.3	6.9	3	16	0.019	68	80
1LA7 163-2AA□□	2.1	6.5	2.9	16	0.034	70	82
1LA7 164-2AA□□	2.2	6.6	3	16	0.043	70	82
1LA7 166-2AA□□	2.4	7	3.1	16	0.051	70	82
1LA5 183-2AA□□	2.5	6.9	3.2	16	0.077	70	83
1LA5 206-2AA□□	2.4	7.2	2.8	16	0.14	71	84
1LA5 207-2AA□□	2.4	7.7	2.8	16	0.16	71	84
1LA5 223-2AA□□	2.8	7.7	3.4	16	0.2	71	84

### Order No. supplements

Motor type	Penultimate position: Voltage code						Final position: Type of construction code						
	50 Hz				60 Hz		Without flange		With flange		With standard flange		With special flange
	230 VΔ/400 VY	400 VΔ/690 VY	500 VY	500 VΔ	460 VY	460 VΔ	IM B3/6/7/8, IM V6 <sup>1)</sup>	IM B5, IM V3 <sup>1)</sup>	IM V1 with protective cover <sup>1) 2) 3)</sup>	IM B35	IM B14, IM V19 <sup>1)</sup>	IM B34	IM B14, IM V19 <sup>1)</sup>
1	6	3	5	1	6	0	1	4	6	2	7	3	
1LA7 05 . . . . □□	○	○	○	–	○	○	□	✓	–	✓	✓	✓	✓
1LA7 06 . . . . □□	○	○	○	–	○	○	□	✓	✓	✓	✓	✓	✓
1LA7 07 . . . . □□	○	○	○	–	○	○	□	✓	✓	✓	✓	✓	✓
1LA7 08 . . . . □□	○	○	○	–	○	○	□	✓	✓	✓	✓	✓	✓
1LA7 09 . . . . □□	○	○	○	–	○	○	□	✓	✓	✓	✓	✓	✓
1LA7 10 . . . . □□	○	○	○	○	○	○	□	✓	✓	✓	✓	✓	✓
1LA7 11 . . . . □□	○	○	○	○	○	○	□	✓	✓	✓	✓	✓	✓
1LA7 13 . . . . □□	○	○	○	○	○	○	□	✓	✓	✓	✓	✓	✓
1LA7 16 . . . . □□	○	○	○	○	○	○	□	✓	✓	✓	✓	✓	✓
1LA5 18 . . . . □□	○	○	○	○	○	○	□	✓ <sup>4)</sup>	✓	✓	–	–	–
1LA5 20 . . . . □□	○	○	○	○	○	○	□	✓ <sup>4)</sup>	✓	✓	–	–	–
1LA5 22 . . . . □□	○	○	○	○	○	○	□	✓ <sup>4)</sup>	✓	✓	–	–	–

- Standard version
- Without additional charge
- ✓ With additional charge
- Not possible

Order other voltages with voltage code **9** in the penultimate position and the corresponding order code (see "Special versions" in the "Selection and ordering data" under "Voltages").

Order other types of construction with type of construction code **9** in the final position and the corresponding order code (see "Special versions" in the "Selection and ordering data" under "Types of construction").

<sup>1)</sup> The following applies for explosion-proof motors: In the case of the types of construction with shaft extension down, the version "with protective cover" is required. For types of construction with shaft extension pointing upwards, a suitable cover must be implemented to prevent small parts from falling into the fan cover (see the standard IEC/EN 60079-0). The cover must not block the cooling air-flow.

<sup>2)</sup> 1LA5 183-... to 1LA5 223-... motors (motor series 1LA5, frame size 180 M to 225 M) can be supplied with two additional eyebolts; specify supplement "Z" and order code **K32**.

<sup>3)</sup> The "Second shaft extension" option, order code **K16** is not possible.

<sup>4)</sup> Type of construction IM V3 is only possible using type of construction code **9** and order code **M1G**.

# IEC Squirrel-Cage Motors

## Explosion-proof motors

Self-ventilated, in Zones 2, 21, 22 with type of prot. "n" or prot. against dust explosions – Aluminum series 1LA7/1LA5

### Selection and ordering data (continued)

Rated output at		Frame size	Operating values at rated output						Order No.	Price	Weight
50 Hz	60 Hz		Rated speed at 50 Hz	Rated torque at 50 Hz	Efficiency at 50 Hz 4/4-load	Efficiency at 50 Hz 3/4-load	Power factor at 50 Hz 4/4-load	Rated current at 400 V, 50 Hz			
$P_{rated}$ kW	$P_{rated}$ kW	FS	$n_{rated}$ rpm	$T_{rated}$ Nm	$\eta_{rated}$ %	$\eta_{rated}$ %	$\cos\phi_{rated}$	$I_{rated}$ A	For Order No. supplements for voltage, type of construction and explosion protection zones according to ATEX, see tables below	IM B3 type of construction approx. $m$ kg	
<b>4-pole, 1500 rpm at 50 Hz, 1800 rpm at 60 Hz, temperature class 155 (F), IP55 degree of protection</b>											
0.06	0.07	56 M	1350	0.42	56	55	0.77	0.2	<b>1LA7 050-4ABQQ</b>	3	
0.09	0.11	56 M	1350	0.64	58	57	0.77	0.29	<b>1LA7 053-4ABQQ</b>	3	
0.12	0.14	63 M	1350	0.85	55	54	0.75	0.42	<b>1LA7 060-4ABQQ</b>	3.5	
0.18	0.21	63 M	1350	1.3	59	60	0.76	0.58	<b>1LA7 063-4ABQQ</b>	4.1	
0.25	0.29	71 M	1350	1.8	60	60	0.78	0.77	<b>1LA7 070-4ABQQ</b>	4.8	
0.37	0.43	71 M	1370	2.6	65	65	0.78	1.06	<b>1LA7 073-4ABQQ</b>	6	
0.55	0.63	80 M	1395	3.8	67	67	0.81	1.46	<b>1LA7 080-4AAQQ</b>	9	
0.75	0.86	80 M	1395	5.1	72	72	0.8	1.91	<b>1LA7 083-4AAQQ</b>	10	
1.1	1.3	90 S	1415	7.4	77	77	0.81	2.55	<b>1LA7 090-4AAQQ</b>	13	
1.5	1.75	90 L	1420	10	79	79	0.81	3.4	<b>1LA7 096-4AAQQ</b>	15.6	
2.2	2.55	100 L	1420	15	82	82.5	0.82	4.7	<b>1LA7 106-4AAQQ</b>	21	
3	3.45	100 L	1420	20	83	83.5	0.82	6.4	<b>1LA7 107-4AAQQ</b>	24	
4	4.6	112 M	1440	27	85	85.5	0.83	8.2	<b>1LA7 113-4AAQQ</b>	31	
5.5	6.3	132 S	1455	36	86	86	0.81	11.4	<b>1LA7 130-4AAQQ</b>	41	
7.5	8.6	132 M	1455	49	87	87.5	0.82	15.2	<b>1LA7 133-4AAQQ</b>	49	
11	12.6	160 M	1460	72	88.5	89	0.84	21.5	<b>1LA7 163-4AAQQ</b>	73	
15	17.3	160 L	1460	98	90	90.2	0.84	28.5	<b>1LA7 166-4AAQQ</b>	85	
18.5	21.3	180 M	1460	121	90.5	90.5	0.83	35.5 <sup>1)</sup>	<b>1LA5 183-4AAQQ</b>	113	
22	25.3	180 L	1460	144	91.2	91.2	0.84	41.5 <sup>1)</sup>	<b>1LA5 186-4AAQQ</b>	123	
30	34.5	200 L	1465	196	91.8	91.8	0.86	55	<b>1LA5 207-4AAQQ</b>	157	
37	42.5	225 S	1470	240	92.9	92.9	0.87	66 <sup>1)</sup>	<b>1LA5 220-4AAQQ</b>	206	
45	52	225 M	1470	292	93.4	93.4	0.87	80 <sup>1)</sup>	<b>1LA5 223-4AAQQ</b>	232	

### Special versions according to ATEX

Motor type	Zone 2		VIK (includes Zone 2) <sup>2)</sup>		Zone 21		Zone 22	
	Mains-fed operation	Converter-fed operation (FC)	Mains-fed operation	Converter-fed operation (FC)	Mains-fed operation	Converter-fed operation (FC)	Mains-fed operation	Converter-fed operation (FC)
Frame size	Order code <b>M72</b>	Order code <b>M73</b>	Order code <b>K30</b>	On request	Order code <b>M34</b>	Order code <b>M38</b>	Order code <b>M35</b>	Order code <b>M39</b>
<b>1LA7</b>	56	–	–	–	–	–	–	–
	63	✓	✓	✓	✓	✓	✓	✓
	71	✓	✓	✓	✓	✓	✓	✓
	80	✓	✓	✓	✓	✓	✓	✓
	90	✓	✓	✓	✓	✓	✓	✓
	100	✓	✓	✓	✓	✓	✓	✓
	112	✓	✓	✓	✓	✓	✓	✓
	132	✓	✓	✓	✓	✓	✓	✓
	160	✓	✓	✓	✓	✓	✓	✓
<b>1LA5</b>	180	–	–	–	–	–	–	–
	200	–	–	–	–	–	–	–
	225	–	–	–	–	–	–	–

✓ With additional charge  
– Not possible

The motors can also be ordered in design for Zones 2 and 22 for non-conducting dust (IP55):

Mains-fed operation – order code **M74**

Converter-fed operation with derating – order code **M75**

See "Special versions" in the "Selection and ordering data" under "Options".

<sup>1)</sup> For connection to 230 V, parallel feeders are necessary (see the "Introduction" section, "Connection, circuit and connection box").

<sup>2)</sup> If the marking Ex nA II is required in addition to VIK on the rating plate, this must be ordered using order code **C27**. The VIK version is not possible in combination with Zone 21 and 22.



# IEC Squirrel-Cage Motors

## Explosion-proof motors

Self-ventilated, in Zones 2, 21, 22 with type of prot. "n" or prot. against dust explosions – Aluminum series 1LA7/1LA5

### Selection and ordering data (continued)

Order No.	Locked-rotor torque with direct starting torque	Locked-rotor current as multiple of rated current	Breakdown torque	Torque class	Moment of inertia	Noise at rated output	
	$T_{LR}/T_{rated}$	$I_{LR}/I_{rated}$	$T_B/T_{rated}$	CL	$J$ kgm <sup>2</sup>	Measuring surface sound pressure level at 50 Hz $L_{pFA}$ dB(A)	Sound pressure level at 50 Hz $L_{WA}$ dB(A)
<b>4-pole, 1500 rpm at 50 Hz, 1800 rpm at 60 Hz, temperature class 155 (F), IP55 degree of protection</b>							
1LA7 050-4AB□□	1.9	2.6	1.9	13	0.00027	42	53
1LA7 053-4AB□□	1.9	2.6	1.9	13	0.00027	42	53
1LA7 060-4AB□□	1.9	2.8	2	13	0.00029	42	53
1LA7 063-4AB□□	1.9	3	1.9	13	0.00037	42	53
1LA7 070-4AB□□	1.9	3	1.9	13	0.00052	44	55
1LA7 073-4AB□□	1.9	3.3	2.1	13	0.00077	44	55
1LA7 080-4AA□□	2.2	3.9	2.2	16	0.0014	47	58
1LA7 083-4AA□□	2.3	4.2	2.3	16	0.0017	47	58
1LA7 090-4AA□□	2.3	4.6	2.4	16	0.0024	50	62
1LA7 096-4AA□□	2.4	5.3	2.6	16	0.0033	50	62
1LA7 106-4AA□□	2.5	5.6	2.8	16	0.0047	56	68
1LA7 107-4AA□□	2.7	5.6	3	16	0.0055	56	68
1LA7 113-4AA□□	2.7	6	3	16	0.012	53	65
1LA7 130-4AA□□	2.5	6.3	3.1	16	0.018	62	74
1LA7 133-4AA□□	2.7	6.7	3.2	16	0.023	62	74
1LA7 163-4AA□□	2.2	6.2	2.7	16	0.043	66	78
1LA7 166-4AA□□	2.6	6.5	3	16	0.055	66	78
1LA5 183-4AA□□	2.3	7.5	3	16	0.13	63	76
1LA5 186-4AA□□	2.3	7.5	3	16	0.15	63	76
1LA5 207-4AA□□	2.6	7	3.2	16	0.24	65	78
1LA5 220-4AA□□	2.8	7	3.2	16	0.32	65	78
1LA5 223-4AA□□	2.8	7.7	3.3	16	0.36	65	78

### Order No. supplements

Motor type	Penultimate position: Voltage code						Final position: Type of construction code						
	50 Hz		60 Hz		60 Hz		Without flange	With flange		With standard flange		With special flange	
	230 VΔ/400 VY	400 VΔ/690 VY	500 VY	500 VΔ	460 VY	460 VΔ	IM B3/6/7/8, IM V6 <sup>1)</sup>	IM B5, IM V3	IM V1 with protective cover <sup>1) 2) 3)</sup>	IM B35	IM B14, IM V19	IM B34	IM B14, IM V19 <sup>1)</sup>
	<b>1</b>	<b>6</b>	<b>3</b>	<b>5</b>	<b>1</b>	<b>6</b>	<b>0</b>	<b>1</b>	<b>4</b>	<b>6</b>	<b>2</b>	<b>7</b>	<b>3</b>
1LA7 05 . . . . □□	○	○	○	–	○	○	□	✓	–	✓	✓	✓	✓
1LA7 06 . . . . □□	○	○	○	–	○	○	□	✓	✓	✓	✓	✓	✓
1LA7 07 . . . . □□	○	○	○	–	○	○	□	✓	✓	✓	✓	✓	✓
1LA7 08 . . . . □□	○	○	○	–	○	○	□	✓	✓	✓	✓	✓	✓
1LA7 09 . . . . □□	○	○	○	–	○	○	□	✓	✓	✓	✓	✓	✓
1LA7 10 . . . . □□	○	○	○	○	○	○	□	✓	✓	✓	✓	✓	✓
1LA7 11 . . . . □□	○	○	○	○	○	○	□	✓	✓	✓	✓	✓	✓
1LA7 13 . . . . □□	○	○	○	○	○	○	□	✓	✓	✓	✓	✓	✓
1LA7 16 . . . . □□	○	○	○	○	○	○	□	✓	✓	✓	✓	✓	✓
1LA5 18 . . . . □□	○	○	○	○	○	○	□	✓ <sup>4)</sup>	✓	✓	–	–	–
1LA5 20 . . . . □□	○	○	○	○	○	○	□	✓ <sup>4)</sup>	✓	✓	–	–	–
1LA5 22 . . . . □□	○	○	○	○	○	○	□	✓ <sup>4)</sup>	✓	✓	–	–	–

- Standard version
- Without additional charge
- ✓ With additional charge
- Not possible

Order other voltages with voltage code **9** in the penultimate position and the corresponding order code (see "Special versions" in the "Selection and ordering data" under "Voltages").

Order other types of construction with type of construction code **9** in the final position and the corresponding order code (see "Special versions" in the "Selection and ordering data" under "Types of construction").

<sup>1)</sup> The following applies for explosion-proof motors: In the case of the types of construction with shaft extension down, the version "with protective cover" is required. For types of construction with shaft extension pointing upwards, a suitable cover must be implemented to prevent small parts from falling into the fan cover (see the standard IEC/EN 60079-0). The cover must not block the cooling air-flow.

<sup>2)</sup> 1LA5 183-... to 1LA5 223-... motors (motor series 1LA5, frame size 180 M to 225 M) can be supplied with two additional eyebolts; specify supplement "Z" and order code **K32**.

<sup>3)</sup> The "Second shaft extension" option, order code **K16** is not possible.

<sup>4)</sup> Type of construction IM V3 is only possible using type of construction code **9** and order code **M1G**.

# IEC Squirrel-Cage Motors

## Explosion-proof motors

Self-ventilated, in Zones 2, 21, 22 with type of prot. "n" or prot. against dust explosions – Aluminum series 1LA7/1LA5

### Selection and ordering data (continued)

Rated output at		Frame size	Operating values at rated output						Rated current at 400 V, 50 Hz	Order No.	Price	Weight
50 Hz	60 Hz		Rated speed at 50 Hz	Rated torque at 50 Hz	Efficiency at 50 Hz 4/4-load	Efficiency at 50 Hz 3/4-load	Power factor at 50 Hz 4/4-load	For Order No. supplements for voltage, type of construction and explosion protection zones according to ATEX, see tables below				
$P_{rated}$ kW	$P_{rated}$ kW	FS	$n_{rated}$ rpm	$T_{rated}$ Nm	$\eta_{rated}$ %	$\eta_{rated}$ %	$\cos\phi_{rated}$	$I_{rated}$ A			$m$ kg	
<b>6-pole, 1000 rpm at 50 Hz, 1200 rpm at 60 Hz, temperature class 155 (F), IP55 degree of protection</b>												
0.09	0.1	63 M	850	1	45	41.5	0.66	0.44	<b>1LA7 063-6AA00</b>		4.1	
0.18	0.21	71 M	850	2	53	54.5	0.68	0.72	<b>1LA7 070-6AA00</b>		5	
0.25	0.29	71 M	830	2.8	60	58.5	0.76	0.79	<b>1LA7 073-6AA00</b>		6.3	
0.37	0.43	80 M	920	3.8	62	60.5	0.72	1.2	<b>1LA7 080-6AA00</b>		9	
0.55	0.63	80 M	910	5.8	67	66.5	0.74	1.6	<b>1LA7 083-6AA00</b>		10	
0.75	0.86	90 S	915	7.8	69	69	0.76	2.05	<b>1LA7 090-6AA00</b>		12.5	
1.1	1.3	90 L	915	11	72	72	0.77	2.85	<b>1LA7 096-6AA00</b>		15.7	
1.5	1.75	100 L	925	15	74	74	0.75	3.9	<b>1LA7 106-6AA00</b>		21	
2.2	2.55	112 M	940	22	78	78.5	0.78	5.2	<b>1LA7 113-6AA00</b>		26	
3	3.45	132 S	950	30	79	79.5	0.76	7.2	<b>1LA7 130-6AA00</b>		38	
4	4.6	132 M	950	40	80.5	80.5	0.76	9.4	<b>1LA7 133-6AA00</b>		44	
5.5	6.3	132 M	950	55	83	83	0.76	12.6	<b>1LA7 134-6AA00</b>		52	
7.5	8.6	160 M	960	75	86	86	0.74	17	<b>1LA7 163-6AA00</b>		74	
11	12.6	160 L	960	109	87.5	87.5	0.74	24.5	<b>1LA7 166-6AA00</b>		95	
15	18	180 L	970	148	89.5	89.5	0.77	31.5	<b>1LA5 186-6AA00</b>		126	
18.5	22	200 L	975	181	90.2	90.2	0.77	38.5	<b>1LA5 206-6AA00</b>		161	
22	26.5	200 L	975	215	90.8	90.8	0.77	45.5	<b>1LA5 207-6AA00</b>		183	
30	36	225 M	978	293	91.8	91.8	0.77	61 <sup>1)</sup>	<b>1LA5 223-6AA00</b>		214	

### Special versions according to ATEX

Motor type	Zone 2		VIK (includes Zone 2) <sup>2)</sup>		Zone 21		Zone 22		
	Mains-fed operation	Converter-fed operation (FC)	Mains-fed operation	Converter-fed operation (FC)	Mains-fed operation	Converter-fed operation (FC)	Mains-fed operation	Converter-fed operation (FC)	
	Frame size	Order code M72	Order code M73	Order code K30	On request	Order code M34	Order code M38	Order code M35	Order code M39
<b>1LA7</b>	63	✓	✓	✓	✓	✓	✓	✓	✓
	71	✓	✓	✓	✓	✓	✓	✓	✓
	80	✓	✓	✓	✓	✓	✓	✓	✓
	90	✓	✓	✓	✓	✓	✓	✓	✓
	100	✓	✓	✓	✓	✓	✓	✓	✓
	112	✓	✓	✓	✓	✓	✓	✓	✓
	132	✓	✓	✓	✓	✓	✓	✓	✓
<b>1LA5</b>	160	✓	✓	✓	✓	✓	✓	✓	✓
	180	–	–	–	–	✓	✓	✓	✓
	200	–	–	–	–	✓	✓	✓	✓
	225	–	–	–	–	✓	✓	✓	✓

- ✓ With additional charge  
– Not possible

The motors can also be ordered in design for Zones 2 and 22 for non-conducting dust (IP55):

Mains-fed operation – order code **M74**

Converter-fed operation with derating – order code **M75**

See "Special versions" in the "Selection and ordering data" under "Options".

<sup>1)</sup> For connection to 230 V, parallel feeders are necessary (see the "Introduction" section, "Connection, circuit and connection box").

<sup>2)</sup> If the marking Ex nA II is required in addition to VIK on the rating plate, this must be ordered using order code **C27**. The VIK version is not possible in combination with Zone 21 and 22.

# IEC Squirrel-Cage Motors

## Explosion-proof motors

Self-ventilated, in Zones 2, 21, 22 with type of prot. "n" or prot. against dust explosions – Aluminum series 1LA7/1LA5

### Selection and ordering data (continued)

Order No.	Locked-rotor torque with direct starting torque	Locked-rotor current as multiple of rated current	Breakdown torque torque	Torque class	Moment of inertia	Noise at rated output	
	$T_{LR}/T_{rated}$	$I_{LR}/I_{rated}$	$T_B/T_{rated}$	CL	$J$ kgm <sup>2</sup>	Measuring surface sound pressure level at 50 Hz $L_{pFA}$ dB(A)	Sound pressure level at 50 Hz $L_{WA}$ dB(A)
<b>6-pole, 1000 rpm at 50 Hz, 1200 rpm at 60 Hz, temperature class 155 (F), IP55 degree of protection</b>							
1LA7 063-6AB□□	1.8	2	1.9	13	0.00037	39	50
1LA7 070-6AA□□	2.1	2.3	1.9	16	0.00055	39	50
1LA7 073-6AA□□	2.2	2.7	2	16	0.0008	39	50
1LA7 080-6AA□□	1.9	3.1	2.1	16	0.0014	40	51
1LA7 083-6AA□□	2.1	3.4	2.2	16	0.0017	40	51
1LA7 090-6AA□□	2.2	3.7	2.2	16	0.0024	43	55
1LA7 096-6AA□□	2.3	3.8	2.3	16	0.0033	43	55
1LA7 106-6AA□□	2.3	4	2.3	16	0.0047	47	59
1LA7 113-6AA□□	2.2	4.6	2.5	16	0.0091	52	64
1LA7 130-6AA□□	1.9	4.2	2.2	16	0.015	63	75
1LA7 133-6AA□□	2.1	4.5	2.4	16	0.019	63	75
1LA7 134-6AA□□	2.3	5	2.6	16	0.025	63	75
1LA7 163-6AA□□	2.1	4.6	2.5	16	0.044	66	78
1LA7 166-6AA□□	2.3	4.8	2.6	16	0.063	66	78
1LA5 186-6AA□□	2	5.2	2.4	16	0.15	66	78
1LA5 206-6AA□□	2.7	5.5	2.8	16	0.24	66	78
1LA5 207-6AA□□	2.8	5.5	2.9	16	0.28	66	78
1LA5 223-6AA□□	2.8	5.7	2.9	16	0.36	66	78

### Order No. supplements

Motor type	Penultimate position: Voltage code					Final position: Type of construction code							
	50 Hz		60 Hz			Without flange	With flange		With standard flange	With special flange			
	230 VΔ/400 VY	400 VΔ/690 VY	500 VY	500 VΔ	460 VY	460 VΔ	IM B3/6/7/8, IM V6 <sup>1)</sup>	IM B5, IM V3 <sup>1)</sup>	IM V1 with protective cover <sup>1) 2) 3)</sup>	IM B35	IM B14, IM V19 <sup>1)</sup>	IM B34	IM B14, IM V19 <sup>1)</sup>
	<b>1</b>	<b>6</b>	<b>3</b>	<b>5</b>	<b>1</b>	<b>6</b>	<b>0</b>	<b>1</b>	<b>4</b>	<b>6</b>	<b>2</b>	<b>7</b>	<b>3</b>
1LA7 06 . . . . □□	○	○	○	–	○	○	□	✓	✓	✓	✓	✓	✓
1LA7 07 . . . . □□	○	○	○	–	○	○	□	✓	✓	✓	✓	✓	✓
1LA7 08 . . . . □□	○	○	○	–	○	○	□	✓	✓	✓	✓	✓	✓
1LA7 09 . . . . □□	○	○	○	–	○	○	□	✓	✓	✓	✓	✓	✓
1LA7 10 . . . . □□	○	○	○	○	○	○	□	✓	✓	✓	✓	✓	✓
1LA7 11 . . . . □□	○	○	○	○	○	○	□	✓	✓	✓	✓	✓	✓
1LA7 13 . . . . □□	○	○	○	○	○	○	□	✓	✓	✓	✓	✓	✓
1LA7 16 . . . . □□	○	○	○	○	○	○	□	✓	✓	✓	✓	✓	✓
1LA5 18 . . . . □□	○	○	○	○	○	○	□	✓ <sup>4)</sup>	✓	✓	–	–	–
1LA5 20 . . . . □□	○	○	○	○	○	○	□	✓ <sup>4)</sup>	✓	✓	–	–	–
1LA5 22 . . . . □□	○	○	○	○	○	○	□	✓ <sup>4)</sup>	✓	✓	–	–	–

- Standard version
- Without additional charge
- ✓ With additional charge
- Not possible

Order other voltages with voltage code **9** in the penultimate position and the corresponding order code (see "Special versions" in the "Selection and ordering data" under "Voltages").

Order other types of construction with type of construction code **9** in the final position and the corresponding order code (see "Special versions" in the "Selection and ordering data" under "Types of construction").

<sup>1)</sup> The following applies for explosion-proof motors: In the case of the types of construction with shaft extension down, the version "with protective cover" is required. For types of construction with shaft extension pointing upwards, a suitable cover must be implemented to prevent small parts from falling into the fan cover (see the standard IEC/EN 60079-0). The cover must not block the cooling air-flow.

<sup>2)</sup> 1LA5 183-... to 1LA5 223-... motors (motor series 1LA5, frame size 180 M to 225 M) can be supplied with two additional eyebolts; specify supplement "Z" and order code **K32**.

<sup>3)</sup> The "Second shaft extension" option, order code **K16** is not possible.

<sup>4)</sup> Type of construction IM V3 is only possible using type of construction code **9** and order code **M1G**.

# IEC Squirrel-Cage Motors

## Explosion-proof motors

Self-ventilated, in Zones 2, 21, 22 with type of prot. "n" or prot. against dust explosions – Aluminum series 1LA7/1LA5

### Selection and ordering data (continued)

Rated output at		Frame size	Operating values at rated output						Rated current at 400 V, 50 Hz	Order No.	Price	Weight
50 Hz	60 Hz		Rated speed at 50 Hz	Rated torque at 50 Hz	Efficiency at 50 Hz 4/4-load	Efficiency at 50 Hz 3/4-load	Power factor at 50 Hz 4/4-load	Rated current at 400 V, 50 Hz				
$P_{rated}$ kW	$P_{rated}$ kW	FS	$n_{rated}$ rpm	$T_{rated}$ Nm	$\eta_{rated}$ %	$\eta_{rated}$ %	$\cos\phi_{rated}$	$I_{rated}$ A	For Order No. supplements for voltage, type of construction and explosion protection zones according to ATEX, see tables below	m	kg	
<b>8-pole, 750 rpm at 50 Hz, 900 rpm at 60 Hz, temperature class 155 (F), IP55 degree of protection</b>												
0.09	0.1	71 M	630	1.4	53	54.5	0.68	0.36	<b>1LA7 070-8ABQQ</b>		6.3	
0.12	0.14	71 M	645	1.8	53	49.5	0.64	0.51	<b>1LA7 073-8ABQQ</b>		6.3	
0.18	0.21	80 M	675	2.5	51	49.5	0.68	0.75	<b>1LA7 080-8ABQQ</b>		9	
0.25	0.29	80 M	685	3.5	55	50.5	0.64	1.02	<b>1LA7 083-8ABQQ</b>		10	
0.37	0.43	90 S	675	5.2	63	62	0.75	1.14	<b>1LA7 090-8ABQQ</b>		10.5	
0.55	0.63	90 L	675	7.8	66	65	0.76	1.58	<b>1LA7 096-8ABQQ</b>		13.2	
0.75	0.86	100 L	680	11	66	65	0.76	2.15	<b>1LA7 106-8ABQQ</b>		19	
1.1	1.3	100 L	680	15	72	72	0.76	2.9	<b>1LA7 107-8ABQQ</b>		22	
1.5	1.75	112 M	705	20	74	74	0.76	3.85	<b>1LA7 113-8ABQQ</b>		24	
2.2	2.55	132 S	700	30	75	75	0.74	5.7	<b>1LA7 130-8ABQQ</b>		38	
3	3.45	132 M	700	41	77	77.5	0.74	7.6	<b>1LA7 133-8ABQQ</b>		44	
4	4.6	160 M	715	53	80	80	0.72	10	<b>1LA7 163-8ABQQ</b>		64	
5.5	6.3	160 M	710	74	83.5	83.5	0.73	13	<b>1LA7 164-8ABQQ</b>		74	
7.5	8.6	160 L	715	100	85.5	85.5	0.72	17.6	<b>1LA7 166-8ABQQ</b>		94	
11	13.2	180 L	725	145	87	87	0.75	24.5	<b>1LA5 186-8ABQQ</b>		128	
15	18	200 L	725	198	87.5	87.5	0.78	31.5	<b>1LA5 207-8ABQQ</b>		176	
18.5	22	225 S	725	244	89.2	89.2	0.79	38	<b>1LA5 220-8ABQQ</b>		184	
22	26.5	225 M	725	290	90.6	90.6	0.79	44.5	<b>1LA5 223-8ABQQ</b>		214	

### Special versions according to ATEX

Motor type	Zone 2		VIK (includes Zone 2) <sup>1)</sup>		Zone 21		Zone 22	
	Mains-fed operation	Converter-fed operation (FC)	Mains-fed operation	Converter-fed operation (FC)	Mains-fed operation	Converter-fed operation (FC)	Mains-fed operation	Converter-fed operation (FC)
Frame size	Order code M72	Order code M73	Order code K30	On request	Order code M34	Order code M38	Order code M35	Order code M39
<b>1LA7</b>	71	✓	✓	✓	✓	✓	✓	✓
	80	✓	✓	✓	✓	✓	✓	✓
	90	✓	✓	✓	✓	✓	✓	✓
	100	✓	✓	✓	✓	✓	✓	✓
	112	✓	✓	✓	✓	✓	✓	✓
	132	✓	✓	✓	✓	✓	✓	✓
160	✓	✓	✓	✓	✓	✓	✓	
<b>1LA5</b>	180	-	-	-	✓	✓	✓	✓
	200	-	-	-	✓	✓	✓	✓
	225	-	-	-	✓	✓	✓	✓

- ✓ With additional charge  
 - Not possible

The motors can also be ordered in design for Zones 2 and 22 for non-conducting dust (IP55):

Mains-fed operation – order code **M74**

Converter-fed operation with derating – order code **M75**

See "Special versions" in the "Selection and ordering data" under "Options".

<sup>1)</sup> If the marking Ex nA II is required in addition to VIK on the rating plate, this must be ordered using order code **C27**. The VIK version is not possible in combination with Zone 21 and 22.

# IEC Squirrel-Cage Motors

## Explosion-proof motors

Self-ventilated, in Zones 2, 21, 22 with type of prot. "n" or prot. against dust explosions – Aluminum series 1LA7/1LA5

### Selection and ordering data (continued)

Order No.	Locked-rotor torque with direct starting torque	Locked-rotor current as multiple of rated current	Breakdown torque torque	Torque class	Moment of inertia	Noise at rated output	
	$T_{LR}/T_{rated}$	$I_{LR}/I_{rated}$	$T_B/T_{rated}$	CL	$J$ kgm <sup>2</sup>	Measuring surface sound pressure level at 50 Hz $L_{pFA}$ dB(A)	Sound pressure level at 50 Hz $L_{WA}$ dB(A)
<b>8-pole, 750 rpm at 50 Hz, 900 rpm at 60 Hz, temperature class 155 (F), IP55 degree of protection</b>							
1LA7 070-8AB□□	1.9	2.2	1.7	13	0.0008	36	47
1LA7 073-8AB□□	2.2	2.2	2	13	0.0008	36	47
1LA7 080-8AB□□	1.7	2.3	1.9	13	0.0014	41	52
1LA7 083-8AB□□	2	2.6	2.2	13	0.0017	41	52
1LA7 090-8AB□□	1.6	2.9	1.8	13	0.0023	41	53
1LA7 096-8AB□□	1.7	3	1.9	13	0.0031	41	53
1LA7 106-8AB□□	1.6	3	1.9	13	0.0051	45	57
1LA7 107-8AB□□	1.8	3.3	2.1	13	0.0063	45	57
1LA7 113-8AB□□	1.8	3.7	2.1	13	0.013	49	61
1LA7 130-8AB□□	1.9	3.9	2.3	13	0.014	53	65
1LA7 133-8AB□□	2.1	4.1	2.4	13	0.019	53	65
1LA7 163-8AB□□	2.2	4.5	2.6	13	0.036	63	75
1LA7 164-8AB□□	2.3	4.7	2.7	13	0.046	63	75
1LA7 166-8AB□□	2.7	5.3	3	13	0.064	63	75
1LA5 186-8AB□□	2	5	2.2	13	0.21	60	73
1LA5 207-8AB□□	2.1	5	2.2	13	0.37	58	71
1LA5 220-8AB□□	2.1	4.5	2.2	13	0.37	58	71
1LA5 223-8AB□□	2.2	4.8	2.3	13	0.45	58	71

### Order No. supplements

Motor type	Penultimate position: Voltage code						Final position: Type of construction code							
	50 Hz						60 Hz		Without flange	With flange		With standard flange		With special flange
	230 VΔ/400 VY	400 VΔ/690 VY	500 VY	500 VΔ	460 VY	460 VΔ	IM B3/6/7/8, IM V6 <sup>1)</sup>	IM B5, IM V3 <sup>1)</sup>	IM V1 with protective cover <sup>1) 2) 3)</sup>	IM B35	IM B14, IM V19 <sup>1)</sup>	IM B34	IM B14, IM V19 <sup>1)</sup>	
1	6	3	5	1	6	0	1	4	6	2	7	3		
1LA7 07 . . . . □□	○	○	○	–	○	○	□	✓	✓	✓	✓	✓	✓	
1LA7 08 . . . . □□	○	○	○	–	○	○	□	✓	✓	✓	✓	✓	✓	
1LA7 09 . . . . □□	○	○	○	–	○	○	□	✓	✓	✓	✓	✓	✓	
1LA7 10 . . . . □□	○	○	○	○	○	○	□	✓	✓	✓	✓	✓	✓	
1LA7 11 . . . . □□	○	○	○	○	○	○	□	✓	✓	✓	✓	✓	✓	
1LA7 13 . . . . □□	○	○	○	○	○	○	□	✓	✓	✓	✓	✓	✓	
1LA7 16 . . . . □□	○	○	○	○	○	○	□	✓	✓	✓	✓	✓	✓	
1LA5 18 . . . . □□	○	○	○	○	○	○	□	✓ <sup>4)</sup>	✓	✓	–	–	–	
1LA5 20 . . . . □□	○	○	○	○	○	○	□	✓ <sup>4)</sup>	✓	✓	–	–	–	
1LA5 22 . . . . □□	○	○	○	○	○	○	□	✓ <sup>4)</sup>	✓	✓	–	–	–	

- Standard version
- Without additional charge
- ✓ With additional charge
- Not possible

Order other voltages with voltage code **9** in the penultimate position and the corresponding order code (see "Special versions" in the "Selection and ordering data" under "Voltages").

Order other types of construction with type of construction code **9** in the final position and the corresponding order code (see "Special versions" in the "Selection and ordering data" under "Types of construction").

<sup>1)</sup> The following applies for explosion-proof motors: In the case of the types of construction with shaft extension down, the version "with protective cover" is required. For types of construction with shaft extension pointing upwards, a suitable cover must be implemented to prevent small parts from falling into the fan cover (see the standard IEC/EN 60079-0). The cover must not block the cooling air-flow.

<sup>2)</sup> 1LA5 183-... to 1LA5 223-... motors (motor series 1LA5, frame size 180 M to 225 M) can be supplied with two additional eyebolts; specify supplement "Z" and order code **K32**.

<sup>3)</sup> The "Second shaft extension" option, order code **K16** is not possible.

<sup>4)</sup> Type of construction IM V3 is only possible using type of construction code **9** and order code **M1G**.

# IEC Squirrel-Cage Motors

## Explosion-proof motors

Self-ventilated, in Zones 2, 21, 22 with type of prot. "n" or prot. against dust explosions – Aluminum series 1LA9

### Selection and ordering data

Rated output at 50 Hz	Frame size	Operating values at rated output						Order No.	Price	Weight
		Rated speed at 50 Hz	Rated torque at 50 Hz	Efficiency at 50 Hz 4/4-load	Efficiency at 50 Hz 3/4-load	Power factor at 50 Hz 4/4-load	Rated current at 400 V, 50 Hz			
$P_{\text{rated}}$ kW	FS	$n_{\text{rated}}$ rpm	$T_{\text{rated}}$ Nm	$\eta_{\text{rated}}$ %	$\eta_{\text{rated}}$ %	$\cos\phi_{\text{rated}}$	$I_{\text{rated}}$ A	For Order No. supplements for voltage, type of construction and explosion protection zones according to ATEX, see tables below	IM B3 type of construction approx. $m$ kg	
<b>2-pole, 3000 rpm at 50 Hz, temperature class 155 (F), IP55 degree of protection, "High Efficiency"</b>										
0.09	56 M	2830	0.3	70	68	0.76	0.24	<b>1LA9 050-2KA00</b>	3	
0.12	56 M	2830	0.4	70	70	0.81	0.31	<b>1LA9 053-2KA00</b>	3.8	
0.18	63 M	2840	0.61	70	70	0.78	0.48	<b>1LA9 060-2KA00</b>	4.1	
0.25	63 M	2840	0.84	72	70	0.8	0.63	<b>1LA9 063-2KA00</b>	5.1	
0.37	71 M	2840	1.2	74	74	0.77	0.94	<b>1LA9 070-2KA00</b>	6	
0.55	71 M	2835	1.9	75	75	0.75	1.42	<b>1LA9 073-2KA00</b>	7.2	
0.75	80 M	2870	2.5	80	80	0.82	1.66	<b>1LA9 080-2KA00</b>	9.8	
1.1	80 M	2860	3.7	84	84	0.89	2.1	<b>1LA9 083-2KA00</b>	12.3	
1.5	90 S	2890	5	85	85	0.87	2.95	<b>1LA9 090-2KA00</b>	15	
2.2	90 L	2890	7.3	86.5	86.5	0.87	4.2	<b>1LA9 096-2KA00</b>	18.6	
3	100 L	2890	9.9	87	87	0.88	5.7	<b>1LA9 106-2KA00</b>	24	
4	112 M	2905	13	88.5	88.5	0.89	7.3	<b>1LA9 113-2KA00</b>	35	
5.5	132 S	2930	18	89.5	89.5	0.9	9.9	<b>1LA9 130-2KA00</b>	43	
7.5	132 S	2930	24	90.5	90.5	0.92	13	<b>1LA9 131-2KA00</b>	56	
11	160 M	2945	36	91	91	0.9	19.4	<b>1LA9 163-2KA00</b>	73	
15	160 M	2945	49	91.5	91.5	0.9	26.5	<b>1LA9 164-2KA00</b>	82	
18.5	160 L	2940	60	92.3	92.5	0.92	31.5	<b>1LA9 166-2KA00</b>	102	
22	180 M	2945	71	93	93.2	0.89	38.5 <sup>1)</sup>	<b>1LA9 183-2WA00</b>	131	
30	200 L	2950	97	93.5	93.5	0.89	52	<b>1LA9 206-2WA00</b>	185	
37	200 L	2950	120	94	94.1	0.89	64 <sup>1)</sup>	<b>1LA9 207-2WA00</b>	214	

### Special versions according to ATEX

Motor type	Zone 2	VIK (includes Zone 2) <sup>2)</sup>				Zone 21		Zone 22	
		Mains-fed operation	Converter-fed operation (FC)	Mains-fed operation	Converter-fed operation (FC)	Mains-fed operation	Converter-fed operation (FC)	Mains-fed operation	Converter-fed operation (FC)
Frame size	Order code M72	Order code M73	Order code K30	On request	Order code M34	Order code M38	Order code M35	Order code M39	
<b>1LA9</b>	56	–	–	–	–	✓	✓	✓	
	63	✓	✓	✓	✓	✓	✓	✓	
	71	✓	✓	✓	✓	✓	✓	✓	
	80	✓	✓	✓	✓	✓	✓	✓	
	90	✓	✓	✓	✓	✓	✓	✓	
	100	✓	✓	✓	✓	✓	✓	✓	
	112	✓	✓	✓	✓	✓	✓	✓	
	132	✓	✓	✓	✓	✓	✓	✓	
	160	✓	✓	✓	✓	✓	✓	✓	
	180	–	–	–	–	✓	✓	✓	
	200	–	–	–	–	✓	✓	✓	

- ✓ With additional charge  
– Not possible

The motors can also be ordered in design for Zones 2 and 22 for non-conducting dust (IP55):

Mains-fed operation – order code **M74**

Converter-fed operation with derating – order code **M75**

See "Special versions" in the "Selection and ordering data" under "Options".

The motors can also be used for 60 Hz according to EPACT, see Pages 4/56 to 4/61.

<sup>1)</sup> For connection to 230 V, parallel feeders are necessary (see the "Introduction" section, "Connection, circuit and connection box").

<sup>2)</sup> If the marking Ex nA II is required in addition to VIK on the rating plate, this must be ordered using order code **C27**. The VIK version is not possible in combination with Zone 21 and 22.

# IEC Squirrel-Cage Motors

## Explosion-proof motors

Self-ventilated, in Zones 2, 21, 22 with type of prot. "n" or prot. against dust explosions – Aluminum series 1LA9

### Selection and ordering data (continued)

Order No.	Locked-rotor torque with direct starting torque	Locked-rotor current as multiple of rated current	Breakdown torque	Torque class	Moment of inertia	Noise at rated output	
	$T_{LR}/T_{rated}$	$I_{LR}/I_{rated}$	$T_B/T_{rated}$	CL	$J$ kgm <sup>2</sup>	Measuring surface sound pressure level at 50 Hz $L_{pFA}$ dB(A)	Sound pressure level at 50 Hz $L_{WA}$ dB(A)
<b>2-pole, 3000 rpm at 50 Hz, temperature class 155 (F), IP55 degree of protection, "High Efficiency"</b>							
1LA9 050-2KA□□	3.6	4.5	3	16	0.00015	41	52
1LA9 053-2KA□□	3.2	4.3	2.8	16	0.0002	41	52
1LA9 060-2KA□□	2.8	4.8	3.1	16	0.00022	49	60
1LA9 063-2KA□□	2.5	4.9	2.5	16	0.00026	49	60
1LA9 070-2KA□□	3.3	6.5	3.1	16	0.00041	52	63
1LA9 073-2KA□□	3.6	6.3	2.9	16	0.0005	52	63
1LA9 080-2KA□□	4.4	8.3	3.2	16	0.001	56	67
1LA9 083-2KA□□	3.8	7	3.2	16	0.0013	56	67
1LA9 090-2KA□□	4.1	7	3.5	16	0.0018	60	72
1LA9 096-2KA□□	4.1	7	3.5	16	0.0022	60	72
1LA9 106-2KA□□	3.4	7	3.2	16	0.0044	62	74
1LA9 113-2KA□□	2.8	7	3.2	16	0.0077	63	75
1LA9 130-2KA□□	2.7	7	3.2	16	0.019	68	80
1LA9 131-2KA□□	2.8	7	3.1	16	0.024	68	80
1LA9 163-2KA□□	2.5	7	3.1	16	0.044	70	82
1LA9 164-2KA□□	2.5	7	3.1	16	0.051	70	82
1LA9 166-2KA□□	2.4	7	3.1	16	0.065	70	82
1LA9 183-2WA□□	2.6	7.2	3.3	16	0.09	70	83
1LA9 206-2WA□□	2.5	7	3.2	16	0.16	71	84
1LA9 207-2WA□□	2.7	7	3.3	16	0.2	71	84

### Order No. supplements

Motor type	Penultimate position: Voltage code 50 Hz				Final position: Type of construction code							
	230 VΔ/400 VY	400 VΔ/690 VY	500 VY	500 VΔ	Without flange IM B3/6/7/8, IM V6 <sup>1)</sup>	With flange IM B5, <sup>1)</sup> IM V3		IM V1 with protective cover <sup>1) 2)</sup>	IM B35	With standard flange IM B14, <sup>1)</sup> IM V19 <sup>1)</sup>		IM B34
	1	6	3	5	0	1	4	6	2	7	3	
1LA9 05 . . . . □□	○	○	○	–	□	✓	–	–	✓	✓	✓	–
1LA9 06 . . . . □□	○	○	○	–	□	✓	✓	✓	✓	✓	✓	–
1LA9 07 . . . . □□	○	○	○	–	□	✓	✓	✓	✓	✓	✓	–
1LA9 08 . . . . □□	○	○	○	–	□	✓	✓	✓	✓	✓	✓	–
1LA9 09 . . . . □□	○	○	○	–	□	✓	✓	✓	✓	✓	✓	–
1LA9 10 . . . . □□	○	○	○	○	□	✓	✓	✓	✓	✓	✓	–
1LA9 11 . . . . □□	○	○	○	○	□	✓	✓	✓	✓	✓	✓	–
1LA9 13 . . . . □□	○	○	○	○	□	✓	✓	✓	✓	✓	✓	–
1LA9 16 . . . . □□	○	○	○	○	□	✓	✓	✓	✓	✓	✓	–
1LA9 18 . . . . □□	○	○	○	○	□	✓ <sup>3)</sup>	✓	✓	–	–	–	–
1LA9 20 . . . . □□	○	○	○	○	□	✓ <sup>3)</sup>	✓	✓	–	–	–	–

- Standard version
- Without additional charge
- ✓ With additional charge
- Not possible

Order other voltages with voltage code **9** in the penultimate position and the corresponding order code (see "Special versions" in the "Selection and ordering data" under "Voltages").

Order other types of construction with type of construction code **9** in the final position and the corresponding order code (see "Special versions" in the "Selection and ordering data" under "Types of construction").

<sup>1)</sup> The following applies for explosion-proof motors: In the case of the types of construction with shaft extension down, the version "with protective cover" is required. For types of construction with shaft extension pointing upwards, a suitable cover must be implemented to prevent small parts from falling into the fan cover (see the standard IEC/EN 60079-0). The cover must not block the cooling air-flow.

<sup>2)</sup> The "Second shaft extension" option, order code **K16** is not possible.

<sup>3)</sup> Type of construction IM V3 is only possible using type of construction code **9** and order code **M1G**.

# IEC Squirrel-Cage Motors

## Explosion-proof motors

Self-ventilated, in Zones 2, 21, 22 with type of prot. "n" or prot. against dust explosions – Aluminum series 1LA9

### Selection and ordering data (continued)

Rated output at 50 Hz	Frame size	Operating values at rated output						Order No.	Price	Weight
		Rated speed at 50 Hz	Rated torque at 50 Hz	Efficiency at 50 Hz 4/4-load	Efficiency at 50 Hz 3/4-load	Power factor at 50 Hz 4/4-load	Rated current at 400 V, 50 Hz			
$P_{\text{rated}}$ kW	FS	$n_{\text{rated}}$ rpm	$T_{\text{rated}}$ Nm	$\eta_{\text{rated}}$ %	$\eta_{\text{rated}}$ %	$\cos\phi_{\text{rated}}$	$I_{\text{rated}}$ A	For Order No. supplements for voltage, type of construction and explosion protection zones according to ATEX, see tables below	m	kg
<b>4-pole, 1500 rpm at 50 Hz, temperature class 155 (F), IP55 degree of protection, "High Efficiency"</b>										
0.06	56 M	1380	0.42	61	61	0.66	0.22	<b>1LA9 050-4KA00</b>		3
0.09	56 M	1390	0.62	62	62	0.68	0.31	<b>1LA9 053-4KA00</b>		3.8
0.12	63 M	1395	0.82	66	66	0.65	0.41	<b>1LA9 060-4KA00</b>		4.1
0.18	63 M	1395	1.3	65	65	0.68	0.59	<b>1LA9 063-4KA00</b>		5.1
0.25	71 M	1410	1.7	70	70	0.64	0.81	<b>1LA9 070-4KA00</b>		6
0.37	71 M	1385	2.6	71	71	0.73	1.04	<b>1LA9 073-4KA00</b>		7.2
0.55	80 M	1410	3.7	77	77	0.78	1.32	<b>1LA9 080-4KA00</b>		9.8
0.75	80 M	1400	5.1	81	81	0.75	1.78	<b>1LA9 083-4KA00</b>		12.3
1.1	90 S	1440	7.3	84	84	0.77	2.45	<b>1LA9 090-4KA00</b>		15
1.5	90 L	1440	9.9	85	85	0.77	3.3	<b>1LA9 096-4KA00</b>		18
2.2	100 L	1435	15	86.5	86.5	0.82	4.5	<b>1LA9 106-4KA00</b>		25
3	100 L	1435	20	87.5	87.7	0.81	6.1	<b>1LA9 107-4KA00</b>		30
4	112 M	1440	27	88.5	89	0.81	8.1	<b>1LA9 113-4KA00</b>		37
5.5	132 S	1455	36	89.5	89.5	0.84	10.6	<b>1LA9 130-4KA00</b>		45
7.5	132 M	1455	49	90.3	90.5	0.84	14.2	<b>1LA9 133-4KA00</b>		60
11	160 M	1460	72	91.5	92	0.85	20.5	<b>1LA9 163-4KA00</b>		81
15	160 L	1460	98	92	92.3	0.86	27.5	<b>1LA9 166-4KA00</b>		107
18.5	180 M	1465	121	92.5	93	0.84	34.5 <sup>1)</sup>	<b>1LA9 183-4WA00</b>		126
22	180 L	1465	143	93	93.4	0.84	40.5 <sup>1)</sup>	<b>1LA9 186-4WA00</b>		146
30	200 L	1465	196	93.5	94	0.87	53	<b>1LA9 207-4WA00</b>		199

### Special versions according to ATEX

Motor type	Zone 2	VIK (includes Zone 2) <sup>2)</sup>				Zone 21		Zone 22	
		Mains-fed operation	Converter-fed operation (FC)	Mains-fed operation	Converter-fed operation (FC)	Mains-fed operation	Converter-fed operation (FC)	Mains-fed operation	Converter-fed operation (FC)
Frame size	Order code M72	Order code M73	Order code K30	On request	Order code M34	Order code M38	Order code M35	Order code M39	
<b>1LA9</b>	56	–	–	–	–	✓	✓	✓	
	63	✓	✓	✓	✓	✓	✓	✓	
	71	✓	✓	✓	✓	✓	✓	✓	
	80	✓	✓	✓	✓	✓	✓	✓	
	90	✓	✓	✓	✓	✓	✓	✓	
	100	✓	✓	✓	✓	✓	✓	✓	
	112	✓	✓	✓	✓	✓	✓	✓	
	132	✓	✓	✓	✓	✓	✓	✓	
	160	✓	✓	✓	✓	✓	✓	✓	
	180	–	–	–	–	✓	✓	✓	
	200	–	–	–	–	✓	✓	✓	

- ✓ With additional charge  
– Not possible

The motors can also be ordered in design for Zones 2 and 22 for non-conducting dust (IP55):

Mains-fed operation – order code **M74**

Converter-fed operation with derating – order code **M75**

See "Special versions" in the "Selection and ordering data" under "Options".

The motors can also be used for 60 Hz according to EPACT, see Pages 4/56 to 4/61.

<sup>1)</sup> For connection to 230 V, parallel feeders are necessary (see the "Introduction" section, "Connection, circuit and connection box").

<sup>2)</sup> If the marking Ex nA II is required in addition to VIK on the rating plate, this must be ordered using order code **C27**. The VIK version is not possible in combination with Zone 21 and 22.



# IEC Squirrel-Cage Motors

## Explosion-proof motors

Self-ventilated, in Zones 2, 21, 22 with type of prot. "n" or prot. against dust explosions – Aluminum series 1LA9

### Selection and ordering data (continued)

Order No.	Locked-rotor torque with direct starting torque	Locked-rotor current as multiple of rated current	Breakdown torque	Torque class	Moment of inertia	Noise at rated output	
	$T_{LR}/T_{rated}$	$I_{LR}/I_{rated}$	$T_B/T_{rated}$	CL	$J$ kgm <sup>2</sup>	Measuring surface sound pressure level at 50 Hz $L_{pFA}$ dB(A)	Sound pressure level at 50 Hz $L_{WA}$ dB(A)
<b>4-pole, 1500 rpm at 50 Hz, temperature class 155 (F), IP55 degree of protection, "High Efficiency"</b>							
1LA9 050-4KA□□	2.7	3.1	2.8	16	0.00027	42	53
1LA9 053-4KA□□	2.8	3.2	2.8	16	0.00035	42	53
1LA9 060-4KA□□	2.7	3.5	2.6	16	0.00037	42	53
1LA9 063-4KA□□	3	3.6	2.5	16	0.00045	42	53
1LA9 070-4KA□□	3.6	4.3	3.1	16	0.00076	44	55
1LA9 073-4KA□□	3.3	4.2	3	16	0.00095	44	55
1LA9 080-4KA□□	3.4	5.6	2.9	16	0.0017	47	58
1LA9 083-4KA□□	4	5.8	3.5	16	0.0024	47	58
1LA9 090-4KA□□	3.1	6.4	3.2	16	0.0033	48	60
1LA9 096-4KA□□	3.6	6.7	3.4	16	0.004	48	60
1LA9 106-4KA□□	3.4	7	3.6	16	0.0062	53	65
1LA9 107-4KA□□	3.8	7	3.9	16	0.0077	53	65
1LA9 113-4KA□□	3.2	6.9	3.2	16	0.014	53	65
1LA9 130-4KA□□	3.2	7	3.6	16	0.023	62	74
1LA9 133-4KA□□	3.4	7	3.6	16	0.029	62	74
1LA9 163-4KA□□	2.6	6.9	3.2	16	0.055	66	78
1LA9 166-4KA□□	2.8	7	3.3	16	0.072	66	78
1LA9 183-4WA□□	2.8	7	3.2	16	0.15	63	76
1LA9 186-4WA□□	3.1	7.3	3.4	16	0.19	63	76
1LA9 207-4WA□□	3	7	3.2	16	0.32	65	78

### Order No. supplements

Motor type	Penultimate position: Voltage code				Final position: Type of construction code						
	50 Hz				Without flange	With flange			With standard flange		With special flange
	230 VΔ/400 VY	400 VΔ/690 VY	500 VY	500 VΔ	IM B3/6/7/8, IM V6 <sup>1)</sup>	IM B5, <sub>1)</sub> IM V3	IM V1 with protective cover <sup>1) 2)</sup>	IM B35	IM B14, <sub>1)</sub> IM V19 <sub>1)</sub>	IM B34	IM B14, <sub>1)</sub> IM V19 <sub>1)</sub>
	1	6	3	5	0	1	4	6	2	7	3
1LA9 05 . . . . □□	○	○	○	–	□	✓	–	–	✓	✓	✓
1LA9 06 . . . . □□	○	○	○	–	□	✓	✓	✓	✓	✓	✓
1LA9 07 . . . . □□	○	○	○	–	□	✓	✓	✓	✓	✓	✓
1LA9 08 . . . . □□	○	○	○	–	□	✓	✓	✓	✓	✓	✓
1LA9 09 . . . . □□	○	○	○	–	□	✓	✓	✓	✓	✓	✓
1LA9 10 . . . . □□	○	○	○	○	□	✓	✓	✓	✓	✓	✓
1LA9 11 . . . . □□	○	○	○	○	□	✓	✓	✓	✓	✓	✓
1LA9 13 . . . . □□	○	○	○	○	□	✓	✓	✓	✓	✓	✓
1LA9 16 . . . . □□	○	○	○	○	□	✓	✓	✓	✓	✓	✓
1LA9 18 . . . . □□	○	○	○	○	□	✓ <sup>3)</sup>	✓	✓	–	–	–
1LA9 20 . . . . □□	○	○	○	○	□	✓ <sup>3)</sup>	✓	✓	–	–	–

- Standard version
- Without additional charge
- ✓ With additional charge
- Not possible

Order other voltages with voltage code **9** in the penultimate position and the corresponding order code (see "Special versions" in the "Selection and ordering data" under "Voltages").

Order other types of construction with type of construction code **9** in the final position and the corresponding order code (see "Special versions" in the "Selection and ordering data" under "Types of construction").

<sup>1)</sup> The following applies for explosion-proof motors: In the case of the types of construction with shaft extension down, the version "with protective cover" is required. For types of construction with shaft extension pointing upwards, a suitable cover must be implemented to prevent small parts from falling into the fan cover (see the standard IEC/EN 60079-0). The cover must not block the cooling air-flow.

<sup>2)</sup> The "Second shaft extension" option, order code **K16** is not possible.

<sup>3)</sup> Type of construction IM V3 is only possible using type of construction code **9** and order code **M1G**.

# IEC Squirrel-Cage Motors

## Explosion-proof motors

Self-ventilated, in Zones 2, 21, 22 with type of prot. "n" or prot. against dust explosions – Aluminum series 1LA9

### Selection and ordering data (continued)

Rated output at 50 Hz $P_{\text{rated}}$ kW	Frame size FS	Operating values at rated output						Order No. For Order No. supplements for voltage, type of construction and explosion protection zones according to ATEX, see tables below	Price	Weight IM B3 type of construction approx. $m$ kg
		Rated speed at 50 Hz $n_{\text{rated}}$ rpm	Rated torque at 50 Hz $T_{\text{rated}}$ Nm	Efficiency at 50 Hz 4/4-load $\eta_{\text{rated}}$ %	Efficiency at 50 Hz 3/4-load $\eta_{\text{rated}}$ %	Power factor at 50 Hz 4/4-load $\cos\phi_{\text{rated}}$	Rated current at 400 V, 50 Hz $I_{\text{rated}}$ A			
<b>6-pole, 1000 rpm at 50 Hz, temperature class 155 (F), IP55 degree of protection, "High Efficiency"</b>										
0.75	90 S	925	7.7	75.5	75.5	0.72	2	<b>1LA9 090-6KAQQ</b>		15.7
1.1	90 L	940	11	82	82	0.7	2.75	<b>1LA9 096-6KAQQ</b>		19
1.5	100 L	935	15	85	85	0.73	3.6	<b>1LA9 106-6KAQQ</b>		25
2.2	112 M	955	22	84	84	0.7	5.4	<b>1LA9 113-6KAQQ</b>		37
4	132 M	950	40	84	84	0.81	8.5	<b>1LA9 133-6KAQQ</b>		49
5.5	132 M	960	55	86	86	0.77	12	<b>1LA9 134-6KAQQ</b>		64
7.5	160 M	965	74	88	88	0.72	17	<b>1LA9 163-6KAQQ</b>		98
11	160 L	960	109	88.5	88.5	0.78	23	<b>1LA9 166-6KAQQ</b>		105
15	180 L	970	148	91	91	0.75	31.5	<b>1LA9 186-6WAQQ</b>		144
18.5	200 L	975	181	91	91	0.77	38	<b>1LA9 206-6WAQQ</b>		186
22	200 L	975	215	91.5	91.5	0.77	45	<b>1LA9 207-6WAQQ</b>		217

### Special versions according to ATEX

Motor type	Zone 2		VIK (includes Zone 2) <sup>1)</sup>		Zone 21		Zone 22		
	Mains-fed operation	Converter-fed operation (FC)	Mains-fed operation	Converter-fed operation (FC)	Mains-fed operation	Converter-fed operation (FC)	Mains-fed operation	Converter-fed operation (FC)	
Frame size	Order code M72	Order code M73	Order code K30	On request	Order code M34	Order code M38	Order code M35	Order code M39	
1LA9	90	✓	✓	✓	✓	✓	✓	✓	
	100	✓	✓	✓	✓	✓	✓	✓	
	112	✓	✓	✓	✓	✓	✓	✓	
	132	✓	✓	✓	✓	✓	✓	✓	
	160	✓	✓	✓	✓	✓	✓	✓	
	180	–	–	–	–	✓	✓	✓	✓
	200	–	–	–	–	✓	✓	✓	✓

- ✓ With additional charge  
– Not possible

The motors can also be ordered in design for Zones 2 and 22 for non-conducting dust (IP55):

Mains-fed operation – order code **M74**

Converter-fed operation with derating – order code **M75**

See "Special versions" in the "Selection and ordering data" under "Options".

The motors can also be used for 60 Hz according to EPACT, see Pages 4/56 to 4/61.

<sup>1)</sup> If the marking Ex nA II is required in addition to VIK on the rating plate, this must be ordered using order code **C27**. The VIK version is not possible in combination with Zone 21 and 22.

# IEC Squirrel-Cage Motors

## Explosion-proof motors

Self-ventilated, in Zones 2, 21, 22 with type of prot. "n" or prot. against dust explosions – Aluminum series 1LA9

### Selection and ordering data (continued)

Order No.	Locked-rotor torque with direct starting torque	Locked-rotor current as multiple of rated current	Breakdown torque torque	Torque class	Moment of inertia	Noise at rated output	
	$T_{LR}/T_{rated}$	$I_{LR}/I_{rated}$	$T_B/T_{rated}$	CL	$J$ kgm <sup>2</sup>	Measuring surface sound pressure level at 50 Hz $L_{pFA}$ dB(A)	Sound pressure level at 50 Hz $L_{WA}$ dB(A)
<b>6-pole, 1000 rpm at 50 Hz, temperature class 155 (F), IP55 degree of protection, "High Efficiency"</b>							
1LA9 090-6KA□□	3.	4.4	2.5	16	0.0033	43	55
1LA9 096-6KA□□	3.7	5.7	3.2	16	0.005	43	55
1LA9 106-6KA□□	3.5	6.2	3.4	16	0.0065	47	59
1LA9 113-6KA□□	2.9	6.2	3	16	0.014	52	64
1LA9 133-6KA□□	3	6.3	2.7	16	0.025	63	75
1LA9 134-6KA□□	3.7	7.3	3.6	16	0.03	63	75
1LA9 163-6KA□□	2.4	5.5	2.5	16	0.063	66	78
1LA9 166-6KA□□	3.1	6.9	3.2	16	0.072	66	78
1LA9 186-6WA□□	2.2	6.5	2.5	16	0.19	66	78
1LA9 206-6WA□□	2.8	6.2	2.5	16	0.28	66	78
1LA9 207-6WA□□	2.8	6.2	2.5	16	0.36	66	78

### Order No. supplements

Motor type	Penultimate position: Voltage code				Final position: Type of construction code						
	50 Hz				Without flange	With flange			With standard flange		With special flange
	230 VΔ/400 VY	400 VΔ/690 VY	500 VY	500 VΔ	IM B3/6/7/8, IM V6 <sup>1)</sup>	IM B5, <sup>1)</sup> IM V3 <sup>1)</sup>	IM V1 with protective cover <sup>1) 2)</sup>	IM B35	IM B14, <sup>1)</sup> IM V19 <sup>1)</sup>	IM B34	IM B14, <sup>1)</sup> IM V19 <sup>1)</sup>
<b>1</b>	<b>6</b>	<b>3</b>	<b>5</b>	<b>0</b>	<b>1</b>	<b>4</b>	<b>6</b>	<b>2</b>	<b>7</b>	<b>3</b>	
1LA9 09 . . . . □□	○	○	○	–	□	✓	✓	✓	✓	✓	✓
1LA9 10 . . . . □□	○	○	○	○	□	✓	✓	✓	✓	✓	✓
1LA9 11 . . . . □□	○	○	○	○	□	✓	✓	✓	✓	✓	✓
1LA9 13 . . . . □□	○	○	○	○	□	✓	✓	✓	✓	✓	✓
1LA9 16 . . . . □□	○	○	○	○	□	✓	✓	✓	✓	✓	✓
1LA9 18 . . . . □□	○	○	○	○	□	✓ <sup>3)</sup>	✓	✓	–	–	–
1LA9 20 . . . . □□	○	○	○	○	□	✓ <sup>3)</sup>	✓	✓	–	–	–

- Standard version
- Without additional charge
- ✓ With additional charge
- Not possible

Order other voltages with voltage code **9** in the penultimate position and the corresponding order code (see "Special versions" in the "Selection and ordering data" under "Voltages").

Order other types of construction with type of construction code **9** in the final position and the corresponding order code (see "Special versions" in the "Selection and ordering data" under "Types of construction").

<sup>1)</sup> The following applies for explosion-proof motors: In the case of the types of construction with shaft extension down, the version "with protective cover" is required. For types of construction with shaft extension pointing upwards, a suitable cover must be implemented to prevent small parts from falling into the fan cover (see the standard IEC/EN 60079-0). The cover must not block the cooling air-flow.

<sup>2)</sup> The "Second shaft extension" option, order code **K16** is not possible.

<sup>3)</sup> Type of construction IM V3 is only possible using type of construction code **9** and order code **M1G**.

# IEC Squirrel-Cage Motors

## Explosion-proof motors

Self-ventilated, in Zones 2, 21, 22 with type of prot. "n" or prot. against dust explosions – Aluminum series 1LA9

### Selection and ordering data

Rated output at 60 Hz $P_{\text{rated}}$ HP	Frame size FS	Operating values at rated output					Power factor at 60 Hz 4/4-load $\cos\phi_{\text{rated}}$	Rated current at 460 V, 60 Hz $I_{\text{rated}}$ A	Order No. For Order No. supplements for voltage, type of construction and explosion protection zones according to ATEX, see tables below	Price	Weight IM B3 type of construction approx. $m$ kg
		Rated speed at 60 Hz $n_{\text{rated}}$ rpm	Rated torque at 60 Hz $T_{\text{rated}}$ Nm	EPACT with CC No. CC 032A	Nominal efficiency at 60 Hz $\eta_{\text{rated}}$ %						
<b>2-pole, 3600 rpm at 60 Hz, temperature class 155 (F), IP55 degree of protection, for use in the North American market according to EPACT</b>											
0.12	56 M	3440	0.25	No	70	0.74	0.23	<b>1LA9 050-2KA□□</b>		3	
0.16	56 M	3440	0.33	No	71	0.76	0.28	<b>1LA9 053-2KA□□</b>		3.8	
0.25	63 M	3440	0.53	No	71	0.79	0.4	<b>1LA9 060-2KA□□</b>		4.1	
0.33	63 M	3460	0.69	No	72	0.76	0.56	<b>1LA9 063-2KA□□</b>		5.1	
0.5	71 M	3445	1	No	72	0.75	0.86	<b>1LA9 070-2KA□□</b>		6	
0.75	71 M	3445	1.6	No	73	0.73	1.3	<b>1LA9 073-2KA□□</b>		7.2	
1	80 M	3485	2	Yes	75.5	0.82	1.52	<b>1LA9 080-2KA□□</b>		9.8	
1.5	80 M	3480	3.1	Yes	82.5	0.88	1.9	<b>1LA9 083-2KA□□</b>		12.3	
2	90 S	3510	4.1	Yes	84	0.86	2.6	<b>1LA9 090-2KA□□</b>		15	
3	90 L	3510	6.1	Yes	85.5	0.85	3.8	<b>1LA9 096-2KA□□</b>		18.6	
4	100 L	3510	8.1	No	86.5	0.87	5	<b>1LA9 106-2KA□□</b>		24	
5	112 M	3540	10	Yes	87.5	0.88	6	<b>1LA9 113-2KA□□</b>		35	
7.5	132 S	3540	15	Yes	88.5	0.9	8.7	<b>1LA9 130-2KA□□</b>		43	
10	132 S	3540	20	Yes	89.5	0.92	11.4	<b>1LA9 131-2KA□□</b>		56	
15	160 M	3555	30	Yes	90.2	0.9	17	<b>1LA9 163-2KA□□</b>		73	
20	160 M	3555	40	Yes	90.2	0.9	23.2	<b>1LA9 164-2KA□□</b>		82	
25	160 L	3550	50	Yes	91	0.92	27.7	<b>1LA9 166-2KA□□</b>		102	
30	180 M	3545	60	Yes	91	0.86	36	<b>1LA9 183-2WA□□</b>		131	
40	200 L	3555	80	Yes	91.7	0.88	46.5	<b>1LA9 206-2WA□□</b>		185	
50	200 L	3555	100	Yes	92.4	0.88	57	<b>1LA9 207-2WA□□</b>		214	

### Special versions according to ATEX

Motor type	Zone 2		VIK (includes Zone 2) <sup>1)</sup>		Zone 21		Zone 22		
	Mains-fed operation	Converter-fed operation (FC)	Mains-fed operation	Converter-fed operation (FC)	Mains-fed operation	Converter-fed operation (FC)	Mains-fed operation	Converter-fed operation (FC)	
Frame size	Order code M72	Order code M73	Order code K30	On request	Order code M34	Order code M38	Order code M35	Order code M39	
1LA9	56	–	–	–	–	✓	✓	✓	
	63	✓	✓	✓	✓	✓	✓	✓	
	71	✓	✓	✓	✓	✓	✓	✓	
	80	✓	✓	✓	✓	✓	✓	✓	
	90	✓	✓	✓	✓	✓	✓	✓	
	100	✓	✓	✓	✓	✓	✓	✓	
	112	✓	✓	✓	✓	✓	✓	✓	
	132	✓	✓	✓	✓	✓	✓	✓	
	160	✓	✓	✓	✓	✓	✓	✓	
	180	–	–	–	–	✓	✓	✓	✓
	200	–	–	–	–	✓	✓	✓	✓

- ✓ With additional charge  
– Not possible

The motors can also be ordered in design for Zones 2 and 22 for non-conducting dust (IP55):  
Mains-fed operation – order code **M74**  
Converter-fed operation with derating – order code **M75**  
See "Special versions" in the "Selection and ordering data" under "Options".

**The motors can also be used for 50 Hz "High Efficiency", see Pages 4/50 to 4/55.**

<sup>1)</sup> If the marking Ex nA II is required in addition to VIK on the rating plate, this must be ordered using order code **C27**. The VIK version is not possible in combination with Zone 21 and 22.

# IEC Squirrel-Cage Motors

## Explosion-proof motors

Self-ventilated, in Zones 2, 21, 22 with type of prot. "n" or prot. against dust explosions – Aluminum series 1LA9

### Selection and ordering data (continued)

Order No.	Locked-rotor torque with direct starting torque	Locked-rotor current as multiple of rated current	Breakdown torque torque	Torque class	Moment of inertia	Noise at rated output	
	$T_{LR}/T_{rated}$	$I_{LR}/I_{rated}$	$T_B/T_{rated}$	CL	$J$ kgm <sup>2</sup>	Measuring surface sound pressure level at 60 Hz $L_{pFA}$ dB(A)	Sound pressure level at 60 Hz $L_{WA}$ dB(A)
<b>2-pole, 3600 rpm at 60 Hz, temperature class 155 (F), IP55 degree of protection, for use in the North American market according to EPACT</b>							
1LA9 050-2KA□□	3.6	5.5	3.8	16	0.00015	45	56
1LA9 053-2KA□□	3.2	5.4	3.4	16	0.0002	45	56
1LA9 060-2KA□□	2.8	4.9	3.3	16	0.00022	53	64
1LA9 063-2KA□□	2.5	5	2.7	16	0.00026	53	64
1LA9 070-2KA□□	3.3	7.5	3.4	16	0.00041	56	67
1LA9 073-2KA□□	3.6	7.2	3.7	16	0.0005	56	67
1LA9 080-2KA□□	4.4	9.6	4.4	16	0.001	60	71
1LA9 083-2KA□□	3.8	8.6	3.2	16	0.0013	60	71
1LA9 090-2KA□□	4.1	8.6	4.1	16	0.0018	64	76
1LA9 096-2KA□□	4.1	8.5	5.1	16	0.0022	64	76
1LA9 106-2KA□□	3.4	8.6	3.7	16	0.0044	66	78
1LA9 113-2KA□□	2.8	9.2	4	16	0.0077	67	79
1LA9 130-2KA□□	2.7	8.5	3.8	16	0.019	72	84
1LA9 131-2KA□□	2.8	8.3	3.7	16	0.024	72	84
1LA9 163-2KA□□	2.5	8.5	3.7	16	0.044	74	86
1LA9 164-2KA□□	2.5	8.5	3.7	16	0.051	74	86
1LA9 166-2KA□□	2.4	8.5	3.5	16	0.065	74	86
1LA9 183-2WA□□	2.6	8.6	3.5	16	0.09	74	87
1LA9 206-2WA□□	2.5	8.4	3.6	16	0.16	75	88
1LA9 207-2WA□□	2.7	8.4	3.7	16	0.2	75	88

### Order No. supplements

Motor type	Penultimate position: Voltage code		Final position: Type of construction code					With standard flange		With special flange
	60 Hz 460 VY	460 VΔ (see "Introduction" for outputs at 60 Hz)	Without flange IM B3/6/7/8, IM V6 <sup>1)</sup>	With flange IM B5, IM V3 <sup>1)</sup>	IM V1 with protective cover <sup>1)2)</sup>	IM B35	IM B14, IM V19 <sup>1)</sup>	IM B34	IM B14, IM V19 <sup>1)</sup>	
	<b>1</b>	<b>6</b>	<b>0</b>	<b>1</b>	<b>4</b>	<b>6</b>	<b>2</b>	<b>7</b>	<b>3</b>	
1LA9 05 . . . . □□	○	○	□	✓	–	–	✓	✓	✓	
1LA9 06 . . . . □□	○	○	□	✓	✓	✓	✓	✓	✓	
1LA9 07 . . . . □□	○	○	□	✓	✓	✓	✓	✓	✓	
1LA9 08 . . . . □□	○	○	□	✓	✓	✓	✓	✓	✓	
1LA9 09 . . . . □□	○	○	□	✓	✓	✓	✓	✓	✓	
1LA9 10 . . . . □□	○	○	□	✓	✓	✓	✓	✓	✓	
1LA9 11 . . . . □□	○	○	□	✓	✓	✓	✓	✓	✓	
1LA9 13 . . . . □□	○	○	□	✓	✓	✓	✓	✓	✓	
1LA9 16 . . . . □□	○	○	□	✓	✓	✓	✓	✓	✓	
1LA9 18 . . . . □□	○	○	□	✓ <sup>3)</sup>	✓	✓	–	–	–	
1LA9 20 . . . . □□	○	○	□	✓ <sup>3)</sup>	✓	✓	–	–	–	

- Standard version
- Without additional charge
- ✓ With additional charge
- Not possible

Order other voltages with voltage code **9** in the penultimate position and the corresponding order code (see "Special versions" in the "Selection and ordering data" under "Voltages").

Order other types of construction with type of construction code **9** in the final position and the corresponding order code (see "Special versions" in the "Selection and ordering data" under "Types of construction").

<sup>1)</sup> The following applies for explosion-proof motors: In the case of the types of construction with shaft extension down, the version "with protective cover" is required. For types of construction with shaft extension pointing upwards, a suitable cover must be implemented to prevent small parts from falling into the fan cover (see the standard IEC/EN 60079-0). The cover must not block the cooling air-flow.

<sup>2)</sup> The "Second shaft extension" option, order code **K16** is not possible.

<sup>3)</sup> Type of construction IM V3 is only possible using type of construction code **9** and order code **M1G**.

# IEC Squirrel-Cage Motors

## Explosion-proof motors

Self-ventilated, in Zones 2, 21, 22 with type of prot. "n" or prot. against dust explosions – Aluminum series 1LA9

### Selection and ordering data (continued)

Rated output at 60 Hz $P_{\text{rated}}$ HP	Frame size FS	Operating values at rated output					Power factor at 60 Hz 4/4-load $\cos\phi_{\text{rated}}$	Rated current at 460 V, 60 Hz $I_{\text{rated}}$ A	Order No. For Order No. supplements for voltage, type of construction and explosion protection zones according to ATEX, see tables below	Price	Weight IM B3 type of construction approx. $m$ kg
		Rated speed at 60 Hz $n_{\text{rated}}$ rpm	Rated torque at 60 Hz $T_{\text{rated}}$ Nm	EPACT with CC No. CC 032A	Nominal efficiency at 60 Hz $\eta_{\text{rated}}$ %						
<b>4-pole, 1800 rpm at 60 Hz, temperature class 155 (F), IP55 degree of protection, for use in the North American market according to EPACT</b>											
0.08	56 M	1715	0.33	No	63	0.65	0.18	<b>1LA9 050-4KA□□</b>		3	
0.12	56 M	1725	0.5	No	64	0.6	0.29	<b>1LA9 053-4KA□□</b>		3.8	
0.16	63 M	1710	0.66	No	68	0.6	0.37	<b>1LA9 060-4KA□□</b>		4.1	
0.25	63 M	1705	1.1	No	66	0.63	0.54	<b>1LA9 063-4KA□□</b>		5.1	
0.33	71 M	1730	1.4	No	69	0.6	0.76	<b>1LA9 070-4KA□□</b>		6	
0.5	71 M	1725	2.1	No	70	0.68	0.98	<b>1LA9 073-4KA□□</b>		7.2	
0.75	80 M	1725	3.1	No	75.5	0.74	1.24	<b>1LA9 080-4KA□□</b>		9.8	
1	80 M	1720	4.1	Yes	82.5	0.75	1.59	<b>1LA9 083-4KA□□</b>		12.3	
1.5	90 S	1755	6.1	Yes	84	0.76	2.15	<b>1LA9 090-4KA□□</b>		15	
2	90 L	1775	14	Yes	84	0.76	2.95	<b>1LA9 096-4KA□□</b>		18	
3	100 L	1750	12	No	87.5	0.79	4	<b>1LA9 106-4KA□□</b>		25	
4	100 L	1750	16	No	87.5	0.79	5.5	<b>1LA9 107-4KA□□</b>		30	
5	112 M	1755	20	Yes	87.5	0.79	6.7	<b>1LA9 113-4KA□□</b>		37	
7.5	132 S	1760	30	Yes	89.5	0.81	9.5	<b>1LA9 130-4KA□□</b>		45	
10	132 M	1760	40	Yes	89.5	0.82	12.8	<b>1LA9 133-4KA□□</b>		60	
15	160 M	1765	61	Yes	91	0.85	17.9	<b>1LA9 163-4KA□□</b>		81	
20	160 L	1765	81	Yes	91	0.85	24.5	<b>1LA9 166-4KA□□</b>		107	
25	180 M	1770	101	Yes	92.4	0.83	30.5	<b>1LA9 183-4WA□□</b>		126	
30	180 L	1770	121	Yes	92.4	0.83	36	<b>1LA9 186-4WA□□</b>		146	
40	200 L	1770	161	Yes	93	0.86	47	<b>1LA9 207-4WA□□</b>		199	

### Special versions according to ATEX

Motor type	Zone 2		VIK (includes Zone 2) <sup>1)</sup>		Zone 21		Zone 22	
	Mains-fed operation	Converter-fed operation (FC)	Mains-fed operation	Converter-fed operation (FC)	Mains-fed operation	Converter-fed operation (FC)	Mains-fed operation	Converter-fed operation (FC)
Frame size	Order code M72	Order code M73	Order code K30	On request	Order code M34	Order code M38	Order code M35	Order code M39
1LA9	56	–	–	–	–	✓	✓	✓
	63	✓	✓	✓	✓	✓	✓	✓
	71	✓	✓	✓	✓	✓	✓	✓
	80	✓	✓	✓	✓	✓	✓	✓
	90	✓	✓	✓	✓	✓	✓	✓
	100	✓	✓	✓	✓	✓	✓	✓
	112	✓	✓	✓	✓	✓	✓	✓
	132	✓	✓	✓	✓	✓	✓	✓
	160	✓	✓	✓	✓	✓	✓	✓
	180	–	–	–	–	✓	✓	✓
200	–	–	–	–	✓	✓	✓	✓

- ✓ With additional charge  
– Not possible

The motors can also be ordered in design for Zones 2 and 22 for non-conducting dust (IP55):  
Mains-fed operation – order code **M74**  
Converter-fed operation with derating – order code **M75**  
See "Special versions" in the "Selection and ordering data" under "Options".

The motors can also be used for 50 Hz "High Efficiency", see Pages 4/50 to 4/55.

<sup>1)</sup> If the marking Ex nA II is required in addition to VIK on the rating plate, this must be ordered using order code **C27**. The VIK version is not possible in combination with Zone 21 and 22.

# IEC Squirrel-Cage Motors

## Explosion-proof motors

Self-ventilated, in Zones 2, 21, 22 with type of prot. "n" or prot. against dust explosions – Aluminum series 1LA9

### Selection and ordering data (continued)

Order No.	Locked-rotor torque with direct starting torque	Locked-rotor current as multiple of rated current	Breakdown torque	Torque class	Moment of inertia	Noise at rated output	
	$T_{LR}/T_{rated}$	$I_{LR}/I_{rated}$	$T_B/T_{rated}$	CL	$J$ kgm <sup>2</sup>	Measuring surface sound pressure level at 60 Hz $L_{pFA}$ dB(A)	Sound pressure level at 60 Hz $L_{WA}$ dB(A)
<b>4-pole, 1800 rpm at 60 Hz, temperature class 155 (F), IP55 degree of protection, for use in the North American market according to EPACT</b>							
1LA9 050-4KA□□	2.7	3.4	3	16	0.00027	46	57
1LA9 053-4KA□□	2.8	3.5	3	16	0.00035	46	57
1LA9 060-4KA□□	2.7	3.9	2.8	16	0.00037	46	57
1LA9 063-4KA□□	3	3.6	3.1	16	0.00045	46	57
1LA9 070-4KA□□	3.6	4.9	3.4	16	0.00076	48	59
1LA9 073-4KA□□	3.3	4.9	3.4	16	0.00095	48	59
1LA9 080-4KA□□	3.4	6.8	3.6	16	0.0017	51	62
1LA9 083-4KA□□	4	7.3	3.9	16	0.0024	51	62
1LA9 090-4KA□□	3.1	7.7	3.9	16	0.0033	52	64
1LA9 096-4KA□□	3.6	8.1	4.2	16	0.004	52	64
1LA9 106-4KA□□	3.4	8.4	4.3	16	0.0062	57	69
1LA9 107-4KA□□	3.8	8.7	4.6	16	0.0077	57	69
1LA9 113-4KA□□	3.2	8.6	3.9	16	0.014	57	69
1LA9 130-4KA□□	3.2	8.7	4.1	16	0.023	66	78
1LA9 133-4KA□□	3.4	8.7	4.1	16	0.029	66	78
1LA9 163-4KA□□	2.6	8.1	3.2	16	0.055	70	82
1LA9 166-4KA□□	2.8	8.5	3.5	16	0.072	70	82
1LA9 183-4WA□□	2.8	8.4	3.6	16	0.15	67	80
1LA9 186-4WA□□	3.1	8.8	3.9	16	0.19	67	80
1LA9 207-4WA□□	3	8.3	3.6	16	0.32	69	82

### Order No. supplements

Motor type	Penultimate position: Voltage code		Final position: Type of construction code						
	60 Hz 460 VY 460 VΔ (see "Introduction" for outputs at 60 Hz)		Without flange IM B3/6/7/8, IM V6 <sup>1)</sup>	With flange IM B5, IM V3 <sup>1)</sup>	IM V1 with protective cover <sup>1)2)</sup>	IM B35	With standard flange IM B14, IM V19 <sup>1)</sup>	IM B34	With special flange IM B14, IM V19 <sup>1)</sup>
	1	6	0	1	4	6	2	7	3
1LA9 05 . . . . □□	○	○	□	✓	–	–	✓	✓	✓
1LA9 06 . . . . □□	○	○	□	✓	✓	✓	✓	✓	✓
1LA9 07 . . . . □□	○	○	□	✓	✓	✓	✓	✓	✓
1LA9 08 . . . . □□	○	○	□	✓	✓	✓	✓	✓	✓
1LA9 09 . . . . □□	○	○	□	✓	✓	✓	✓	✓	✓
1LA9 10 . . . . □□	○	○	□	✓	✓	✓	✓	✓	✓
1LA9 11 . . . . □□	○	○	□	✓	✓	✓	✓	✓	✓
1LA9 13 . . . . □□	○	○	□	✓	✓	✓	✓	✓	✓
1LA9 16 . . . . □□	○	○	□	✓	✓	✓	✓	✓	✓
1LA9 18 . . . . □□	○	○	□	✓ <sup>3)</sup>	✓	✓	–	–	–
1LA9 20 . . . . □□	○	○	□	✓ <sup>3)</sup>	✓	✓	–	–	–

- Standard version
- Without additional charge
- ✓ With additional charge
- Not possible

Order other voltages with voltage code **9** in the penultimate position and the corresponding order code (see "Special versions" in the "Selection and ordering data" under "Voltages").

Order other types of construction with type of construction code **9** in the final position and the corresponding order code (see "Special versions" in the "Selection and ordering data" under "Types of construction").

<sup>1)</sup> The following applies for explosion-proof motors: In the case of the types of construction with shaft extension down, the version "with protective cover" is required. For types of construction with shaft extension pointing upwards, a suitable cover must be implemented to prevent small parts from falling into the fan cover (see the standard IEC/EN 60079-0). The cover must not block the cooling air-flow.

<sup>2)</sup> The "Second shaft extension" option, order code **K16** is not possible.

<sup>3)</sup> Type of construction IM V3 is only possible using type of construction code **9** and order code **M1G**.

# IEC Squirrel-Cage Motors

## Explosion-proof motors

Self-ventilated, in Zones 2, 21, 22 with type of prot. "n" or prot. against dust explosions – Aluminum series 1LA9

### Selection and ordering data (continued)

Rated output at 60 Hz $P_{\text{rated}}$ HP	Frame size FS	Operating values at rated output					Power factor at 60 Hz 4/4-load $\cos\phi_{\text{rated}}$	Rated current at 460 V, 60 Hz $I_{\text{rated}}$ A	Order No. For Order No. supplements for voltage, type of construction and explosion protection zones according to ATEX, see tables below	Price	Weight IM B3 type of construction approx. $m$ kg
		Rated speed at 60 Hz $n_{\text{rated}}$ rpm	Rated torque at 60 Hz $T_{\text{rated}}$ Nm	EPACT with CC No. CC 032A	Nominal efficiency at 60 Hz $\eta_{\text{rated}}$ %						
<b>6-pole, 1200 rpm at 60 Hz, temperature class 155 (F), IP55 degree of protection, for use in the North American market according to EPACT</b>											
1	90 S	1140	6.2	Yes	80	0.66	1.78	<b>1LA9 090-6KA□□</b>		15.7	
1.5	90 L	1150	9.3	Yes	85.5	0.64	2.55	<b>1LA9 096-6KA□□</b>		19	
2	100 L	1150	12	No	86.5	0.7	3.1	<b>1LA9 106-6KA□□</b>		25	
3	112 M	1160	18	Yes	87.5	0.66	4.8	<b>1LA9 113-6KA□□</b>		37	
5	132 M	1160	31	Yes	87.5	0.77	6.9	<b>1LA9 133-6KA□□</b>		49	
7.5	132 M	1160	46	Yes	89.5	0.73	10.6	<b>1LA9 134-6KA□□</b>		64	
10	160 M	1165	61	Yes	89.5	0.7	15	<b>1LA9 163-6KA□□</b>		98	
15	160 L	1165	92	Yes	90.2	0.77	19	<b>1LA9 166-6KA□□</b>		105	
20	180 L	1175	121	Yes	90.2	0.75	28	<b>1LA9 186-6WA□□</b>		144	
25	200 L	1175	152	Yes	91.7	0.75	34	<b>1LA9 206-6WA□□</b>		186	
30	200 L	1175	182	Yes	91.7	0.75	40	<b>1LA9 207-6WA□□</b>		217	

### Special versions according to ATEX

Motor type	Frame size	Zone 2		VIK (includes Zone 2) <sup>1)</sup>		Zone 21		Zone 22	
		Mains-fed operation Order code M72	Converter-fed operation (FC) Order code M73	Mains-fed operation Order code K30	Converter-fed operation (FC) On request	Mains-fed operation Order code M34	Converter-fed operation (FC) Order code M38	Mains-fed operation Order code M35	Converter-fed operation (FC) Order code M39
1LA9	90	✓	✓	✓	✓	✓	✓	✓	✓
	100	✓	✓	✓	✓	✓	✓	✓	✓
	112	✓	✓	✓	✓	✓	✓	✓	✓
	132	✓	✓	✓	✓	✓	✓	✓	✓
	160	✓	✓	✓	✓	✓	✓	✓	✓
	180	–	–	–	–	✓	✓	✓	✓
	200	–	–	–	–	✓	✓	✓	✓

- ✓ With additional charge  
– Not possible

The motors can also be ordered in design for Zones 2 and 22 for non-conducting dust (IP55):

Mains-fed operation – order code **M74**

Converter-fed operation with derating – order code **M75**

See "Special versions" in the "Selection and ordering data" under "Options".

The motors can also be used for 50 Hz "High Efficiency", see Pages 4/50 to 4/55.

<sup>1)</sup> If the marking Ex nA II is required in addition to VIK on the rating plate, this must be ordered using order code **C27**. The VIK version is not possible in combination with Zone 21 and 22.



# IEC Squirrel-Cage Motors

## Explosion-proof motors

Self-ventilated, in Zones 2, 21, 22 with type of prot. "n" or prot. against dust explosions – Aluminum series 1LA9

### Selection and ordering data (continued)

Order No.	Locked-rotor torque with direct starting torque	Locked-rotor current as multiple of rated current	Breakdown torque torque	Torque class	Moment of inertia	Noise at rated output	
	$T_{LR}/T_{rated}$	$I_{LR}/I_{rated}$	$T_B/T_{rated}$	CL	$J$ kgm <sup>2</sup>	Measuring surface sound pressure level at 60 Hz $L_{pFA}$ dB(A)	Sound pressure level at 60 Hz $L_{WA}$ dB(A)
<b>6-pole, 1200 rpm at 60 Hz, temperature class 155 (F), IP55 degree of protection, for use in the North American market according to EPACT</b>							
<b>1LA9 090-6KA□□</b>	3	5.6	3	16	0.0033	47	59
<b>1LA9 096-6KA□□</b>	3.7	6.4	3.7	16	0.005	47	59
<b>1LA9 106-6KA□□</b>	3.5	7.2	3.8	16	0.0065	51	63
<b>1LA9 113-6KA□□</b>	2.9	7.5	3.7	16	0.014	56	68
<b>1LA9 133-6KA□□</b>	3	7.9	3.6	16	0.025	67	79
<b>1LA9 134-6KA□□</b>	3.7	8.4	4.3	16	0.03	67	79
<b>1LA9 163-6KA□□</b>	2.4	6.4	2.8	16	0.063	70	82
<b>1LA9 166-6KA□□</b>	3.1	8.3	3.8	16	0.072	70	82
<b>1LA9 186-6WA□□</b>	2.8	7.1	2.8	16	0.19	70	82
<b>1LA9 206-6WA□□</b>	2.8	7.1	2.8	16	0.28	70	82
<b>1LA9 207-6WA□□</b>	2.8	7.2	2.8	16	0.36	70	82

### Order No. supplements

Motor type	Penultimate position: Voltage code		Final position: Type of construction code						
	60 Hz 460 VY (see "Introduction" for outputs at 60 Hz)	460 VΔ	Without flange IM B3/6/7/8, IM V6 <sup>1)</sup>	With flange IM B5, IM V3 <sup>1)</sup>	IM V1 with protective cover <sup>1)2)</sup>	IM B35	With standard flange IM B14, <sup>1)</sup> IM V19 <sup>1)</sup>	IM B34	With special flange IM B14, IM V19 <sup>1)</sup>
	<b>1</b>	<b>6</b>	<b>0</b>	<b>1</b>	<b>4</b>	<b>6</b>	<b>2</b>	<b>7</b>	<b>3</b>
<b>1LA9 09 . . . . □□</b>	○	○	□	✓	✓	✓	✓	✓	✓
<b>1LA9 10 . . . . □□</b>	○	○	□	✓	✓	✓	✓	✓	✓
<b>1LA9 11 . . . . □□</b>	○	○	□	✓	✓	✓	✓	✓	✓
<b>1LA9 13 . . . . □□</b>	○	○	□	✓	✓	✓	✓	✓	✓
<b>1LA9 16 . . . . □□</b>	○	○	□	✓	✓	✓	✓	✓	✓
<b>1LA9 18 . . . . □□</b>	○	○	□	✓ <sup>3)</sup>	✓	✓	–	–	–
<b>1LA9 20 . . . . □□</b>	○	○	□	✓ <sup>3)</sup>	✓	✓	–	–	–

- Standard version
- Without additional charge
- ✓ With additional charge
- Not possible

Order other voltages with voltage code **9** in the penultimate position and the corresponding order code (see "Special versions" in the "Selection and ordering data" under "Voltages").

Order other types of construction with type of construction code **9** in the final position and the corresponding order code (see "Special versions" in the "Selection and ordering data" under "Types of construction").

<sup>1)</sup> The following applies for explosion-proof motors: In the case of the types of construction with shaft extension down, the version "with protective cover" is required. For types of construction with shaft extension pointing upwards, a suitable cover must be implemented to prevent small parts from falling into the fan cover (see the standard IEC/EN 60079-0). The cover must not block the cooling air-flow.

<sup>2)</sup> The "Second shaft extension" option, order code **K16** is not possible.

<sup>3)</sup> Type of construction IM V3 is only possible using type of construction code **9** and order code **M1G**.

# IEC Squirrel-Cage Motors

## Explosion-proof motors

Self-ventilated, in Zones 2, 21, 22 with type of prot. "n" or prot. against dust explosions – Cast-iron series 1LA6/1LG4

### Selection and ordering data

Rated output at		Frame size	Operating values at rated output						Order No.	Price	Weight
50 Hz	60 Hz		Rated speed at 50 Hz	Rated torque at 50 Hz	Efficiency at 50 Hz 4/4-load	Efficiency at 50 Hz 3/4-load	Power factor at 50 Hz 4/4-load	Rated current at 400 V, 50 Hz			
$P_{rated}$ kW	$P_{rated}$ kW	FS	$n_{rated}$ rpm	$T_{rated}$ Nm	$\eta_{rated}$ %	$\eta_{rated}$ %	$\cos\phi_{rated}$	$I_{rated}$ A	For Order No. supplements for voltage, type of construction and explosion protection zones according to ATEX, see tables below	m kg	
<b>2-pole, 3000 rpm at 50 Hz, 3600 rpm at 60 Hz, temperature class 155 (F), IP55 degree of protection</b>											
3	3.45	100 L	2890	9.9	84	84	0.85	6.1	<b>1LA6 106-2AAQQ</b>	34	
4	4.6	112 M	2905	13	86	86	0.86	7.8	<b>1LA6 113-2AAQQ</b>	43	
5.5	6.3	132 S	2925	18	86.5	86.5	0.89	10.4	<b>1LA6 130-2AAQQ</b>	53	
7.5	8.6	132 S	2930	24	88	88	0.89	13.8	<b>1LA6 131-2AAQQ</b>	58	
11	12.6	160 M	2940	36	89.5	89.5	0.88	20	<b>1LA6 163-2AAQQ</b>	96	
15	17.3	160 M	2940	49	90	90.2	0.9	26.5	<b>1LA6 164-2AAQQ</b>	105	
18.5	21.3	160 L	2940	60	91	91.2	0.91	32	<b>1LA6 166-2AAQQ</b>	115	
22	24.5	180 M	2945	71	91.6	91.6	0.86	40.5 <sup>1)</sup>	<b>1LG4 183-2AAQQ</b>	145	
30	33.5	200 L	2950	97	91.8	91.9	0.88	54 <sup>1)</sup>	<b>1LG4 206-2AAQQ</b>	205	
37	41.5	200 L	2955	120	92.9	93.2	0.89	65 <sup>1)</sup>	<b>1LG4 207-2AAQQ</b>	225	
45	51	225 M	2960	145	93.6	93.9	0.88	79 <sup>1)</sup>	<b>1LG4 223-2AAQQ</b>	285	
55	62	250 M	2970	177	93.6	93.8	0.88	96	<b>1LG4 253-2ABQQ</b>	375	
75	84	280 S	2975	241	94.5	94.3	0.88	130 <sup>1)</sup>	<b>1LG4 280-2ABQQ</b>	500	
90	101	280 M	2975	289	95.1	95.2	0.89	154 <sup>1)</sup>	<b>1LG4 283-2ABQQ</b>	540	
110	123	315 S	2982	352	94.6	93.8	0.88	190 <sup>1)</sup>	<b>1LG4 310-2ABQQ</b>	720	
132	148	315 M	2982	423	95.1	94.8	0.9	225 <sup>1)</sup>	<b>1LG4 313-2ABQQ</b>	775	
160	180	315 L	2982	512	95.5	95.3	0.91	265 <sup>2)</sup>	<b>1LG4 316-2ABQQ</b>	900	
200	224	315 L	2982	641	95.9	95.8	0.92	325 <sup>2)</sup>	<b>1LG4 317-2ABQQ</b>	1015	

### Special versions according to ATEX

Motor type	Zone 2		VIK (includes Zone 2) <sup>3)</sup>		Zone 21		Zone 22	
	Mains-fed operation	Converter-fed operation (FC)	Mains-fed operation	Converter-fed operation (FC)	Mains-fed operation	Converter-fed operation (FC)	Mains-fed operation	Converter-fed operation (FC)
Frame size	Order code M72	Order code M73	Order code K30	On request	Order code M34	Order code M38	Order code M35	Order code M39
<b>1LA6</b>	100	✓	✓	✓	–	–	✓	✓
	112	✓	✓	✓	✓	–	✓	✓
	132	✓	✓	✓	✓	–	✓	✓
	160	✓	✓	✓	✓	–	✓	✓
<b>1LG4</b>	180	✓	✓	✓	✓	✓	✓	✓
	200	✓	✓	✓	✓	✓	✓	✓
	225	✓	✓	✓	✓	✓	✓	✓
	250	✓	✓	✓	✓	✓	✓	✓
	280	✓	✓	✓	✓	✓	✓	✓
	315	✓	✓	✓	✓	✓	✓	✓

✓ With additional charge  
– Not possible

The motors can also be ordered in design for Zones 2 and 22 for non-conducting dust (IP55):

Mains-fed operation – order code **M74**

Converter-fed operation with derating – order code **M75**

See "Special versions" in the "Selection and ordering data" under "Options".

<sup>1)</sup> For connection to 230 V, parallel feeders are necessary (see the "Introduction" section, "Connection, circuit and connection box").

<sup>2)</sup> For connection to 400 V, parallel feeders are necessary (see the "Introduction" section, "Connection, circuit and connection box").

<sup>3)</sup> If the marking Ex nA II is required in addition to VIK on the rating plate, this must be ordered using order code **C27**. The VIK version is not possible in combination with Zone 21 and 22.

# IEC Squirrel-Cage Motors

## Explosion-proof motors

Self-ventilated, in Zones 2, 21, 22 with type of prot. "n" or prot. against dust explosions – Cast-iron series 1LA6/1LG4

### Selection and ordering data (continued)

Order No.	Locked-rotor torque with direct starting torque	Locked-rotor current as multiple of rated current	Breakdown torque	Torque class	Moment of inertia	Noise at rated output	
	$T_{LR}/T_{rated}$	$I_{LR}/I_{rated}$	$T_B/T_{rated}$	CL	$J$ kgm <sup>2</sup>	Measuring surface sound pressure level at 50 Hz $L_{pFA}$ dB(A)	Sound pressure level at 50 Hz $L_{WA}$ dB(A)
<b>2-pole, 3000 rpm at 50 Hz, 3600 rpm at 60 Hz, temperature class 155 (F), IP55 degree of protection</b>							
1LA6 106-2AA□□	2.8	6.8	3	16	0.0035	62	74
1LA6 113-2AA□□	2.6	7.2	2.9	16	0.0059	63	75
1LA6 130-2AA□□	2	5.9	2.8	16	0.015	68	80
1LA6 131-2AA□□	2.3	6.9	3	16	0.019	68	80
1LA6 163-2AA□□	2.1	6.5	2.9	16	0.034	70	82
1LA6 164-2AA□□	2.2	6.6	3	16	0.043	70	82
1LA6 166-2AA□□	2.4	7	3.1	16	0.051	70	82
1LG4 183-2AA□□	2.5	6.4	3.4	16	0.068	67	80
1LG4 206-2AA□□	2.3	6.5	3	16	0.13	74	87
1LG4 207-2AA□□	2.5	7.2	3.3	16	0.15	73	86
1LG4 223-2AA□□	2.4	6.7	3.1	16	0.22	73	86
1LG4 253-2AB□□	2.1	6.7	3.1	13	0.4	75	88
1LG4 280-2AB□□	2.5	7.5	3.1	13	0.72	74	87
1LG4 283-2AB□□	2.6	7.2	3.1	13	0.83	74	87
1LG4 310-2AB□□	2.4	7.2	3.1	13	1.2	81	95
1LG4 313-2AB□□	2.4	6.9	3	13	1.4	80	94
1LG4 316-2AB□□	2.4	7	3	13	1.6	79	92
1LG4 317-2AB□□	2.3	6.7	2.9	13	2.1	79	92

### Order No. supplements

Motor type	Penultimate position: Voltage code						Final position: Type of construction code						
	50 Hz		60 Hz		60 Hz		Without flange	With flange		With standard flange		With special flange	
	230 VΔ/400 VY	400 VΔ/690 VY	500 VY	500 VΔ	460 VY	460 VΔ	IM B3/6/7/8, IM V6 <sup>1)2)</sup>	IM B5, IM V3 <sup>1)3)</sup>	IM V1 With protective cover <sup>1)3)4)</sup>	IM B 35	IM B14, IM V19 <sup>1)</sup>	IM B34	IM B14, IM V19 <sup>1)</sup>
	<b>1</b>	<b>6</b>	<b>3</b>	<b>5</b>	<b>1</b>	<b>6</b>	<b>0</b>	<b>1</b>	<b>4</b>	<b>6</b>	<b>2</b>	<b>7</b>	<b>3</b>
1LA6 10 - . . . □□	○	○	○	○	○	○	□	✓	✓	✓	✓	✓	✓
1LA6 11 - . . . □□	○	○	○	○	○	○	□	✓	✓	✓	✓	✓	✓
1LA6 13 - . . . □□	○	○	○	○	○	○	□	✓	✓	✓	✓	✓	✓
1LA6 16 - . . . □□	○	○	○	○	○	○	□	✓	✓	✓	✓	✓	✓
1LG4 18 - . . . □□	○	○	○	○	○	○	□	✓ <sup>5)</sup>	✓	✓	–	–	–
1LG4 20 - . . . □□	○	○	○	○	○	○	□	✓ <sup>5)</sup>	✓	✓	–	–	–
1LG4 22 - . . . □□	○	○	○	○	○	○	□	✓ <sup>5)</sup>	✓	✓	–	–	–
1LG4 25 - . . . □□	○	○	○	○	○	○	□	✓ <sup>5)</sup>	✓	✓	–	–	–
1LG4 28 - . . . □□	○	○	○	○	○	○	□	✓ <sup>5)</sup>	✓	✓	–	–	–
1LG4 310 - . . . □□	○	○	○	○	○	○	□	✓ <sup>5)</sup>	✓	✓	–	–	–
1LG4 313 - . . . □□	○	○	○	○	○	○	□	✓ <sup>5)</sup>	✓	✓	–	–	–
1LG4 316 - . . . □□	–	○	–	○	–	○	□ <sup>6)</sup>	–	✓ <sup>7)</sup>	✓	–	–	–
1LG4 317 - . . . □□	–	○	–	○	–	○	□ <sup>6)</sup>	–	✓ <sup>7)</sup>	✓	–	–	–

- Standard version
- Without additional charge
- ✓ With additional charge
- Not possible

Order other voltages with voltage code **9** in the penultimate position and the corresponding order code (see "Special versions" in the "Selection and ordering data" under "Voltages").

Order other types of construction with type of construction code **9** in the final position and the corresponding order code (see "Special versions" in the "Selection and ordering data" under "Types of construction").

- 1) The following applies for explosion-proof motors: In the case of the types of construction with shaft extension down, the version "with protective cover" is required. For types of construction with shaft extension pointing upwards, a suitable cover must be implemented to prevent small parts from falling into the fan cover (see the standard IEC/EN 60079-0). The cover must not block the cooling air-flow.
- 2) If motors 1LG4 183-... to 1LG4 318-... (motor series 1LG4 frame sizes 180 M to 315 L) in types of construction with feet IM B6, IM B7 or IM V6 are fixed to the wall, it is recommended that the motor feet are supported.

- 3) 1LG4 220-... to 1LG4 318-... motors (motor series 225 S to 315 L) are supplied with two screw-in eyebolts in accordance with IM B5, whereby one can be relocated in accordance with IM V1 or IM V3. It is important to note that stress must not be applied perpendicular to the ring plane.
- 4) The "Second shaft extension" option, order code **K16** is not possible.
- 5) Type of construction IM V3 is only possible using type of construction code **9** and order code **M1G**.
- 6) Type of construction IM V6 is only possible using type of construction code **9** and order code **M1E**.
- 7) 2-pole motors in 60 Hz version available on request.

# IEC Squirrel-Cage Motors

## Explosion-proof motors

Self-ventilated, in Zones 2, 21, 22 with type of prot. "n" or prot. against dust explosions – Cast-iron series 1LA6/1LG4

### Selection and ordering data (continued)

Rated output at		Frame size	Operating values at rated output						Rated current at 400 V, 50 Hz	Order No.	Price	Weight
50 Hz	60 Hz		Rated speed at 50 Hz	Rated torque at 50 Hz	Efficiency at 50 Hz 4/4-load	Efficiency at 50 Hz 3/4-load	Power factor at 50 Hz 4/4-load	Rated current at 400 V, 50 Hz				
$P_{rated}$ kW	$P_{rated}$ kW	FS	$n_{rated}$ rpm	$T_{rated}$ Nm	$\eta_{rated}$ %	$\eta_{rated}$ %	$\cos\phi_{rated}$	$I_{rated}$ A	For Order No. supplements for voltage, type of construction and explosion protection zones according to ATEX, see tables below	m	kg	
<b>4-pole, 1500 rpm at 50 Hz, 1800 rpm at 60 Hz, temperature class 155 (F), IP55 degree of protection</b>												
2.2	2.55	100 L	1420	15	82	82.5	0.82	4.7	<b>1LA6 106-4AA□□</b>		33	
3	3.45	100 L	1420	20	83	83.5	0.82	6.4	<b>1LA6 107-4AA□□</b>		36	
4	4.6	112 M	1440	27	85	85.5	0.83	8.2	<b>1LA6 113-4AA□□</b>		45	
5.5	6.3	132 S	1455	36	86	86	0.81	11.4	<b>1LA6 130-4AA□□</b>		55	
7.5	8.6	132 M	1455	49	87	87.5	0.82	15.2	<b>1LA6 133-4AA□□</b>		62	
11	12.6	160 M	1460	72	88.5	89	0.84	21.5	<b>1LA6 163-4AA□□</b>		100	
15	17.3	160 L	1460	98	90	90.2	0.84	28.5	<b>1LA6 166-4AA□□</b>		114	
18.5	21.3	180 M	1465	121	90.4	90.8	0.84	35 <sup>1)</sup>	<b>1LG4 183-4AA□□</b>		140	
22	25.3	180 L	1465	143	91	91.5	0.84	41.5 <sup>1)</sup>	<b>1LG4 186-4AA□□</b>		155	
30	34.5	200 L	1465	196	91.6	92	0.85	56 <sup>1)</sup>	<b>1LG4 207-4AA□□</b>		205	
37	42.5	225 S	1475	240	92.2	92.6	0.85	68 <sup>1)</sup>	<b>1LG4 220-4AA□□</b>		265	
45	52	225 M	1475	291	93.1	93.6	0.86	81 <sup>1)</sup>	<b>1LG4 223-4AA□□</b>		300	
55	63	250 M	1480	355	93.5	93.8	0.85	100	<b>1LG4 253-4AA□□</b>		390	
75	86	280 S	1485	482	94.2	94.1	0.85	136 <sup>1)</sup>	<b>1LG4 280-4AA□□</b>		535	
90	104	280 M	1485	579	94.6	94.6	0.86	160 <sup>1)</sup>	<b>1LG4 283-4AA□□</b>		580	
110	127	315 S	1488	706	94.6	94.6	0.85	198 <sup>1)</sup>	<b>1LG4 310-4AA□□</b>		730	
132	152	315 M	1488	847	95.2	95.2	0.85	235 <sup>1)</sup>	<b>1LG4 313-4AA□□</b>		810	
160	184	315 L	1486	1028	95.7	95.8	0.86	280 <sup>2)</sup>	<b>1LG4 316-4AA□□</b>		955	
200	230	315 L	1486	1285	95.9	96.2	0.88	340 <sup>2)</sup>	<b>1LG4 317-4AA□□</b>		1060	

### Special versions according to ATEX

Motor type	Frame size	Zone 2		VIK (includes Zone 2) <sup>3)</sup>		Zone 21		Zone 22	
		Mains-fed operation	Converter-fed operation (FC)	Mains-fed operation	Converter-fed operation (FC)	Mains-fed operation	Converter-fed operation (FC)	Mains-fed operation	Converter-fed operation (FC)
		Order code <b>M72</b>	Order code <b>M73</b>	Order code <b>K30</b>	On request	Order code <b>M34</b>	Order code <b>M38</b>	Order code <b>M35</b>	Order code <b>M39</b>
<b>1LA6</b>	100	✓	✓	✓	✓	–	–	✓	✓
	112	✓	✓	✓	✓	–	–	✓	✓
	132	✓	✓	✓	✓	–	–	✓	✓
	160	✓	✓	✓	✓	–	–	✓	✓
<b>1LG4</b>	180	✓	✓	✓	✓	✓	✓	✓	✓
	200	✓	✓	✓	✓	✓	✓	✓	✓
	225	✓	✓	✓	✓	✓	✓	✓	✓
	250	✓	✓	✓	✓	✓	✓	✓	✓
	280	✓	✓	✓	✓	✓	✓	✓	✓
	315	✓	✓	✓	✓	✓	✓	✓	✓

- ✓ With additional charge  
– Not possible

The motors can also be orderd in design for Zones 2 and 22 for non-conducting dust (IP55):

Mains-fed operation – order code **M74**

Converter-fed operation with derating – order code **M75**

See "Special versions" in the "Selection and ordering data" under "Options".

<sup>1)</sup> For connection to 230 V, parallel feeders are necessary (see the "Introduction" section, "Connection, circuit and connection box").  
<sup>2)</sup> For connection to 400 V, parallel feeders are necessary (see the "Introduction" section, "Connection, circuit and connection box").

<sup>3)</sup> If the marking Ex nA II is required in addition to VIK on the rating plate, this must be ordered using order code **C27**. The VIK version is not possible in combination with Zone 21 and 22.

# IEC Squirrel-Cage Motors

## Explosion-proof motors

Self-ventilated, in Zones 2, 21, 22 with type of prot. "n" or prot. against dust explosions – Cast-iron series 1LA6/1LG4

### Selection and ordering data (continued)

Order No.	Locked-rotor torque with direct starting torque	Locked-rotor current as multiple of rated current	Breakdown torque	Torque class	Moment of inertia	Noise at rated output	
	$T_{LR}/T_{rated}$	$I_{LR}/I_{rated}$	$T_B/T_{rated}$	CL	$J$ kgm <sup>2</sup>	Measuring surface sound pressure level at 50 Hz $L_{pFA}$ dB(A)	Sound pressure level at 50 Hz $L_{WA}$ dB(A)
<b>4-pole, 1500 rpm at 50 Hz, 1800 rpm at 60 Hz, temperature class 155 (F), IP55 degree of protection</b>							
1LA6 106-4AA□□	2.5	5.6	2.8	16	0.0047	53	65
1LA6 107-4AA□□	2.7	5.6	3	16	0.0055	53	65
1LA6 113-4AA□□	2.7	6	3	16	0.012	53	65
1LA6 130-4AA□□	2.5	6.3	3.1	16	0.018	62	74
1LA6 133-4AA□□	2.7	6.7	3.2	16	0.023	62	74
1LA6 163-4AA□□	2.2	6.2	2.7	16	0.043	66	78
1LA6 166-4AA□□	2.6	6.5	3	16	0.055	66	78
1LG4 183-4AA□□	2.4	6.7	3.1	16	0.099	65	78
1LG4 186-4AA□□	2.5	6.9	3.2	16	0.12	65	78
1LG4 207-4AA□□	2.5	6.7	3.4	16	0.19	66	79
1LG4 220-4AA□□	2.3	6.7	3.1	16	0.37	66	79
1LG4 223-4AA□□	2.6	7.2	3.2	16	0.45	66	79
1LG4 253-4AA□□	2.4	6.1	2.8	16	0.69	65	78
1LG4 280-4AA□□	2.5	7.1	3	16	1.2	70	83
1LG4 283-4AA□□	2.5	7.4	3	16	1.4	68	82
1LG4 310-4AA□□	2.5	6.4	2.8	16	1.9	70	83
1LG4 313-4AA□□	2.7	6.8	2.9	16	2.3	70	83
1LG4 316-4AA□□	2.7	6.8	2.8	16	2.9	70	83
1LG4 317-4AA□□	2.6	6.5	2.8	16	3.5	71	86

### Order No. supplements

Motor type	Penultimate position: Voltage code						Final position: Type of construction code						
	50 Hz			60 Hz			Without flange	With flange		With standard flange	With special flange		
	230 VΔ/400 VY	400 VΔ/690 VY	500 VY	500 VΔ	460 VY	460 VΔ	IM B3/6/7/8, IM V6 <sup>1)2)</sup>	IM B5, IM V3 <sup>1)3)</sup>	IM V1 With protective cover <sup>1)3)4)</sup>	IM B 35	IM B14, IM V19 <sup>1)</sup>	IM B34	IM B14, IM V19 <sup>1)</sup>
1	6	3	5	1	6	0	1	4	6	2	7	3	
1LA6 10-...□□	○	○	○	○	○	○	□	✓	✓	✓	✓	✓	✓
1LA6 11-...□□	○	○	○	○	○	○	□	✓	✓	✓	✓	✓	✓
1LA6 13-...□□	○	○	○	○	○	○	□	✓	✓	✓	✓	✓	✓
1LA6 16-...□□	○	○	○	○	○	○	□	✓	✓	✓	✓	✓	✓
1LG4 18-...□□	○	○	○	○	○	○	□	✓ <sup>5)</sup>	✓	✓	–	–	–
1LG4 20-...□□	○	○	○	○	○	○	□	✓ <sup>5)</sup>	✓	✓	–	–	–
1LG4 22-...□□	○	○	○	○	○	○	□	✓ <sup>5)</sup>	✓	✓	–	–	–
1LG4 25-...□□	○	○	○	○	○	○	□	✓ <sup>5)</sup>	✓	✓	–	–	–
1LG4 28-...□□	○	○	○	○	○	○	□	✓ <sup>5)</sup>	✓	✓	–	–	–
1LG4 310-...□□	○	○	○	○	○	○	□	✓ <sup>5)</sup>	✓	✓	–	–	–
1LG4 313-...□□	○	○	○	○	○	○	□	✓ <sup>5)</sup>	✓	✓	–	–	–
1LG4 316-...□□	–	○	–	○	–	○	□ <sup>6)</sup>	–	✓	✓	–	–	–
1LG4 317-...□□	–	○	–	○	–	○	□ <sup>6)</sup>	–	✓	✓	–	–	–

- Standard version
- Without additional charge
- ✓ With additional charge
- Not possible

Order other voltages with voltage code **9** in the penultimate position and the corresponding order code (see "Special versions" in the "Selection and ordering data" under "Voltages").

Order other types of construction with type of construction code **9** in the final position and the corresponding order code (see "Special versions" in the "Selection and ordering data" under "Types of construction").

- 1) The following applies for explosion-proof motors: In the case of the types of construction with shaft extension down, the version "with protective cover" is required. For types of construction with shaft extension pointing upwards, a suitable cover must be implemented to prevent small parts from falling into the fan cover (see the standard IEC/EN 60079-0). The cover must not block the cooling air-flow.
- 2) If motors 1LG4 183-... to 1LG4 318-... (motor series 1LG4 frame sizes 180 M to 315 L) in types of construction with feet IM B6, IM B7 or IM V6 are fixed to the wall, it is recommended that the motor feet are supported.

- 3) 1LG4 220-... to 1LG4 318-... motors (motor series 225 S to 315 L) are supplied with two screw-in eyebolts in accordance with IM B5, whereby one can be relocated in accordance with IM V1 or IM V3. It is important to note that stress must not be applied perpendicular to the ring plane.
- 4) The "Second shaft extension" option, order code **K16** is not possible.
- 5) Type of construction IM V3 is only possible using type of construction code **9** and order code **M1G**.
- 6) Type of construction IM V6 is only possible using type of construction code **9** and order code **M1E**.

# IEC Squirrel-Cage Motors

## Explosion-proof motors

Self-ventilated, in Zones 2, 21, 22 with type of prot. "n" or prot. against dust explosions – Cast-iron series 1LA6/1LG4

### Selection and ordering data (continued)

Rated output at		Frame size	Operating values at rated output						Order No.	Price	Weight
50 Hz	60 Hz		Rated speed at 50 Hz	Rated torque at 50 Hz	Efficiency at 50 Hz 4/4-load	Efficiency at 50 Hz 3/4-load	Power factor at 50 Hz 4/4-load	Rated current at 400 V, 50 Hz			
$P_{rated}$ kW	$P_{rated}$ kW	FS	$n_{rated}$ rpm	$T_{rated}$ Nm	$\eta_{rated}$ %	$\eta_{rated}$ %	$\cos\phi_{rated}$	$I_{rated}$ A	For Order No. supplements for voltage, type of construction and explosion protection zones according to ATEX, see tables below	IM B3 type of construction approx. $m$ kg	
<b>6-pole, 1000 rpm at 50 Hz, 1200 rpm at 60 Hz, temperature class 155 (F), IP55 degree of protection</b>											
1.5	1.75	100 L	925	15	74	74	0.75	3.9	<b>1LA6 106-6AA□□</b>	33	
2.2	2.55	112 M	940	22	78	78.5	0.78	5.2	<b>1LA6 113-6AA□□</b>	40	
3	3.45	132 S	950	30	79	79.5	0.76	7.2	<b>1LA6 130-6AA□□</b>	50	
4	4.6	132 M	950	40	80.5	80.5	0.76	9.4	<b>1LA6 133-6AA□□</b>	57	
5.5	6.3	132 M	950	55	83	83	0.76	12.6	<b>1LA6 134-6AA□□</b>	66	
7.5	8.6	160 M	960	75	86	86	0.74	17	<b>1LA6 163-6AA□□</b>	103	
11	12.6	160 L	960	109	87.5	87.5	0.74	24.5	<b>1LA6 166-6AA□□</b>	122	
15	18	180 L	965	148	88.9	90.3	0.83	29.5	<b>1LG4 186-6AA□□</b>	150	
18.5	22	200 L	975	181	89.8	90.2	0.81	36.5	<b>1LG4 206-6AA□□</b>	195	
22	26.5	200 L	975	215	90.3	91	0.81	43.5	<b>1LG4 207-6AA□□</b>	205	
30	36	225 M	978	293	91.8	92.8	0.83	57 <sup>1)</sup>	<b>1LG4 223-6AA□□</b>	280	
37	44.5	250 M	980	361	92.3	93	0.83	70	<b>1LG4 253-6AA□□</b>	370	
45	54	280 S	985	436	92.4	93.1	0.85	83	<b>1LG4 280-6AA□□</b>	475	
55	66	280 M	985	533	92.7	93.3	0.86	100	<b>1LG4 283-6AA□□</b>	510	
75	90	315 S	988	725	93.5	93.7	0.84	138	<b>1LG4 310-6AA□□</b>	685	
90	108	315 M	988	870	93.9	94.2	0.84	164 <sup>1)</sup>	<b>1LG4 313-6AA□□</b>	750	
110	132	315 L	988	1063	94.3	94.6	0.86	196	<b>1LG4 316-6AA□□</b>	890	
132	158	315 L	988	1276	94.8	95	0.86	235	<b>1LG4 317-6AA□□</b>	980	
160	192	315 L	988	1547	95	95.1	0.86	285 <sup>2)</sup>	<b>1LG4 318-6AA□□</b>	1180	

### Special versions according to ATEX

Motor type	Frame size	Zone 2		VIK (includes Zone 2) <sup>3)</sup>		Zone 21		Zone 22	
		Mains-fed operation Order code <b>M72</b>	Converter-fed operation (FC) Order code <b>M73</b>	Mains-fed operation Order code <b>K30</b>	Converter-fed operation (FC) On request	Mains-fed operation Order code <b>M34</b>	Converter-fed operation (FC) Order code <b>M38</b>	Mains-fed operation Order code <b>M35</b>	Converter-fed operation (FC) Order code <b>M39</b>
<b>1LA6</b>	100	✓	✓	✓	✓	–	–	✓	✓
	112	✓	✓	✓	✓	–	–	✓	✓
	132	✓	✓	✓	✓	–	–	✓	✓
	160	✓	✓	✓	✓	–	–	✓	✓
<b>1LG4</b>	180	✓	✓	✓	✓	✓	✓	✓	✓
	200	✓	✓	✓	✓	✓	✓	✓	✓
	225	✓	✓	✓	✓	✓	✓	✓	✓
	250	✓	✓	✓	✓	✓	✓	✓	✓
	280	✓	✓	✓	✓	✓	✓	✓	✓
	315	✓	✓	✓	✓	✓	✓	✓	✓

- ✓ With additional charge  
– Not possible

The motors can also be orderd in design for Zones 2 and 22 for non-conducting dust (IP55):

Mains-fed operation – order code **M74**

Converter-fed operation with derating – order code **M75**

See "Special versions" in the "Selection and ordering data" under "Options".

<sup>1)</sup> For connection to 230 V, parallel feeders are necessary (see the "Introduction" section, "Connection, circuit and connection box").  
<sup>2)</sup> For connection to 400 V, parallel feeders are necessary (see the "Introduction" section, "Connection, circuit and connection box").

<sup>3)</sup> If the marking Ex nA II is required in addition to VIK on the rating plate, this must be ordered using order code **C27**. The VIK version is not possible in combination with Zone 21 and 22.

# IEC Squirrel-Cage Motors

## Explosion-proof motors

Self-ventilated, in Zones 2, 21, 22 with type of prot. "n" or prot. against dust explosions – Cast-iron series 1LA6/1LG4

### Selection and ordering data (continued)

Order No.	Locked-rotor torque with direct starting torque	Locked-rotor current as multiple of rated current	Breakdown torque torque	Torque class	Moment of inertia	Noise at rated output	
	$T_{LR}/T_{rated}$	$I_{LR}/I_{rated}$	$T_B/T_{rated}$	CL	$J$ kgm <sup>2</sup>	Measuring surface sound pressure level at 50 Hz $L_{pFA}$ dB(A)	Sound pressure level at 50 Hz $L_{WA}$ dB(A)
<b>6-pole, 1000 rpm at 50 Hz, 1200 rpm at 60 Hz, temperature class 155 (F), IP55 degree of protection</b>							
<b>1LA6 106-6AA□□</b>	2.3	4	2.3	16	0.0047	47	59
<b>1LA6 113-6AA□□</b>	2.2	4.6	2.5	16	0.0091	52	64
<b>1LA6 130-6AA□□</b>	1.9	4.2	2.2	16	0.015	63	75
<b>1LA6 133-6AA□□</b>	2.1	4.5	2.4	16	0.019	63	75
<b>1LA6 134-6AA□□</b>	2.3	5	2.6	16	0.025	63	75
<b>1LA6 163-6AA□□</b>	2.1	4.6	2.5	16	0.044	66	78
<b>1LA6 166-6AA□□</b>	2.3	4.8	2.6	16	0.063	66	78
<b>1LG4 186-6AA□□</b>	2.3	5.3	2.5	16	0.18	57	73
<b>1LG4 206-6AA□□</b>	2.5	5.6	2.5	16	0.24	58	73
<b>1LG4 207-6AA□□</b>	2.6	5.7	2.5	16	0.29	58	73
<b>1LG4 223-6AA□□</b>	2.7	5.6	2.5	16	0.49	59	73
<b>1LG4 253-6AA□□</b>	2.7	6	2.3	16	0.76	60	75
<b>1LG4 280-6AA□□</b>	2.4	6.1	2.4	16	1.1	61	75
<b>1LG4 283-6AA□□</b>	2.5	6.3	2.5	16	1.4	61	75
<b>1LG4 310-6AA□□</b>	2.5	6.5	2.8	16	2.1	63	77
<b>1LG4 313-6AA□□</b>	2.6	6.8	2.9	16	2.5	63	77
<b>1LG4 316-6AA□□</b>	2.5	6.8	2.9	16	3.2	64	78
<b>1LG4 317-6AA□□</b>	3.1	7.3	3	16	4	64	78
<b>1LG4 318-6AA□□</b>	3	7.5	3	16	4.7	65	79

### Order No. supplements

Motor type	Penultimate position: Voltage code						Final position: Type of construction code						
	50 Hz		60 Hz				Without flange	With flange		With standard flange	With special flange		
	230 VΔ/400 VY	400 VΔ/690 VY	500 VY	500 VΔ	460 VY	460 VΔ	IM B3/6/7/8, IM V6 <sup>1)2)</sup>	IM B5, IM V3 <sup>1)3)</sup>	IM V1 With protective cover <sup>1)3)4)</sup>	IM B 35 IM V19 <sup>1)</sup>	IM B14, IM B34	IM B14, IM V19 <sup>1)</sup>	
	<b>1</b>	<b>6</b>	<b>3</b>	<b>5</b>	<b>1</b>	<b>6</b>	<b>0</b>	<b>1</b>	<b>4</b>	<b>6</b>	<b>2</b>	<b>7</b>	<b>3</b>
<b>1LA6 10 - ... □□</b>	○	○	○	○	○	○	□	✓	✓	✓	✓	✓	✓
<b>1LA6 11 - ... □□</b>	○	○	○	○	○	○	□	✓	✓	✓	✓	✓	✓
<b>1LA6 13 - ... □□</b>	○	○	○	○	○	○	□	✓	✓	✓	✓	✓	✓
<b>1LA6 16 - ... □□</b>	○	○	○	○	○	○	□	✓	✓	✓	✓	✓	✓
<b>1LG4 18 - ... □□</b>	○	○	○	○	○	○	□	✓ <sup>5)</sup>	✓	✓	-	-	-
<b>1LG4 20 - ... □□</b>	○	○	○	○	○	○	□	✓ <sup>5)</sup>	✓	✓	-	-	-
<b>1LG4 22 - ... □□</b>	○	○	○	○	○	○	□	✓ <sup>5)</sup>	✓	✓	-	-	-
<b>1LG4 25 - ... □□</b>	○	○	○	○	○	○	□	✓ <sup>5)</sup>	✓	✓	-	-	-
<b>1LG4 28 - ... □□</b>	○	○	○	○	○	○	□	✓ <sup>5)</sup>	✓	✓	-	-	-
<b>1LG4 310 - ... □□</b>	○	○	○	○	○	○	□	✓ <sup>5)</sup>	✓	✓	-	-	-
<b>1LG4 313 - ... □□</b>	○	○	○	○	○	○	□	✓ <sup>5)</sup>	✓	✓	-	-	-
<b>1LG4 316 - ... □□</b>	-	○	-	○	-	○	□ <sup>6)</sup>	-	✓	✓	-	-	-
<b>1LG4 317 - ... □□</b>													
<b>1LG4 318 - ... □□</b>													

- Standard version
- Without additional charge
- ✓ With additional charge
- Not possible

Order other voltages with voltage code **9** in the penultimate position and the corresponding order code (see "Special versions" in the "Selection and ordering data" under "Voltages").

Order other types of construction with type of construction code **9** in the final position and the corresponding order code (see "Special versions" in the "Selection and ordering data" under "Types of construction").

- 1) The following applies for explosion-proof motors: In the case of the types of construction with shaft extension down, the version "with protective cover" is required. For types of construction with shaft extension pointing upwards, a suitable cover must be implemented to prevent small parts from falling into the fan cover (see the standard IEC/EN 60079-0). The cover must not block the cooling air-flow.
- 2) If motors 1LG4 183-... to 1LG4 318-... (motor series 1LG4 frame sizes 180 M to 315 L) in types of construction with feet IM B6, IM B7 or IM V6 are fixed to the wall, it is recommended that the motor feet are supported.

- 3) 1LG4 220-... to 1LG4 318-... motors (motor series 225 S to 315 L) are supplied with two screw-in eyebolts in accordance with IM B5, whereby one can be relocated in accordance with IM V1 or IM V3. It is important to note that stress must not be applied perpendicular to the ring plane.
- 4) The "Second shaft extension" option, order code **K16** is not possible.
- 5) Type of construction IM V3 is only possible using type of construction code **9** and order code **M1G**.
- 6) Type of construction IM V6 is only possible using type of construction code **9** and order code **M1E**.

# IEC Squirrel-Cage Motors

## Explosion-proof motors

Self-ventilated, in Zones 2, 21, 22 with type of prot. "n" or prot. against dust explosions – Cast-iron series 1LA6/1LG4

### Selection and ordering data (continued)

Rated output at		Frame size	Operating values at rated output						Rated current at 400 V, 50 Hz	Order No.	Price	Weight
50 Hz	60 Hz		Rated speed at 50 Hz	Rated torque at 50 Hz	Efficiency at 50 Hz 4/4-load	Efficiency at 50 Hz 3/4-load	Power factor at 50 Hz 4/4-load					
$P_{rated}$ kW	$P_{rated}$ kW	FS	$n_{rated}$ rpm	$T_{rated}$ Nm	$\eta_{rated}$ %	$\eta_{rated}$ %	$\cos\phi_{rated}$	$I_{rated}$ A	For Order No. supplements for voltage, type of construction and explosion protection zones according to ATEX, see tables below	m	kg	
<b>8-pole, 750 rpm at 50 Hz, 900 rpm at 60 Hz, temperature class 155 (F), IP55 degree of protection</b>												
0.75	0.86	100 L	680	11	66	65	0.76	2.15	<b>1LA6 106-8ABQQ</b>		29	
1.1	1.3	100 L	680	15	72	72	0.76	2.9	<b>1LA6 107-8ABQQ</b>		32	
1.5	1.75	112 M	705	20	74	74	0.76	3.85	<b>1LA6 113-8ABQQ</b>		39	
2.2	2.55	132 S	700	30	75	75	0.74	5.7	<b>1LA6 130-8ABQQ</b>		50	
3	3.45	132 M	700	41	77	77.5	0.74	7.6	<b>1LA6 133-8ABQQ</b>		57	
4	4.6	160 M	715	53	80	80	0.72	10	<b>1LA6 163-8ABQQ</b>		91	
5.5	6.3	160 M	710	74	83.5	83.5	0.73	13	<b>1LA6 164-8ABQQ</b>		102	
7.5	8.6	160 L	715	100	85.5	85.5	0.72	17.6	<b>1LA6 166-8ABQQ</b>		122	
11	13.2	180 L	725	145	87.5	88.3	0.73	25	<b>1LG4 186-8ABQQ</b>		150	
15	18	200 L	725	198	87.7	88.4	0.76	32.5	<b>1LG4 207-8ABQQ</b>		205	
18.5	22	225 S	730	242	89.4	90.4	0.78	38.5	<b>1LG4 220-8ABQQ</b>		270	
22	26.5	225 M	730	288	89.7	90.7	0.79	45	<b>1LG4 223-8ABQQ</b>		290	
30	36	250 M	730	392	91.4	92.2	0.81	58	<b>1LG4 253-8ABQQ</b>		385	
37	44.5	280 S	735	481	92	92.8	0.81	72	<b>1LG4 280-8ABQQ</b>		475	
45	54	280 M	735	585	92.4	93.3	0.81	87	<b>1LG4 283-8ABQQ</b>		515	
55	66	315 S	740	710	93	93.4	0.81	106	<b>1LG4 310-8ABQQ</b>		680	
75	90	315 M	738	971	93.3	94	0.83	140	<b>1LG4 313-8ABQQ</b>		745	
90	108	315 L	738	1165	93.4	94	0.83	168	<b>1LG4 316-8ABQQ</b>		865	
110	132	315 L	738	1423	94	94.4	0.83	205	<b>1LG4 317-8ABQQ</b>		1020	
132	158	315 L	738	1708	94.2	94.6	0.83	245	<b>1LG4 318-8ABQQ</b>		1100	

### Special versions according to ATEX

Motor type	Zone 2		VIK (includes Zone 2) <sup>1)</sup>		Zone 21		Zone 22	
	Mains-fed operation	Converter-fed operation (FC)	Mains-fed operation	Converter-fed operation (FC)	Mains-fed operation	Converter-fed operation (FC)	Mains-fed operation	Converter-fed operation (FC)
Frame size	Order code <b>M72</b>	Order code <b>M73</b>	Order code <b>K30</b>	On request	Order code <b>M34</b>	Order code <b>M38</b>	Order code <b>M35</b>	Order code <b>M39</b>
<b>1LA6</b>	100	✓	✓	✓	–	–	✓	✓
	112	✓	✓	✓	✓	–	✓	✓
	132	✓	✓	✓	✓	–	✓	✓
	160	✓	✓	✓	✓	–	✓	✓
<b>1LG4</b>	180	✓	✓	✓	✓	✓	✓	✓
	200	✓	✓	✓	✓	✓	✓	✓
	225	✓	✓	✓	✓	✓	✓	✓
	250	✓	✓	✓	✓	✓	✓	✓
	280	✓	✓	✓	✓	✓	✓	✓
	315	✓	✓	✓	✓	✓	✓	✓

- ✓ With additional charge  
– Not possible

The motors can also be ordered in design for Zones 2 and 22 for non-conducting dust (IP55):

Mains-fed operation – order code **M74**

Converter-fed operation with derating – order code **M75**

See "Special versions" in the "Selection and ordering data" under "Options".

<sup>1)</sup> If the marking Ex nA II is required in addition to VIK on the rating plate, this must be ordered using order code **C27**. The VIK version is not possible in combination with Zone 21 and 22.



# IEC Squirrel-Cage Motors

## Explosion-proof motors

Self-ventilated, in Zones 2, 21, 22 with type of prot. "n" or prot. against dust explosions – Cast-iron series 1LA6/1LG4

### Selection and ordering data (continued)

Order No.	Locked-rotor torque with direct starting torque	Locked-rotor current as multiple of rated current	Breakdown torque torque	Torque class	Moment of inertia	Noise at rated output	
	$T_{LR}/T_{rated}$	$I_{LR}/I_{rated}$	$T_B/T_{rated}$	CL	$J$ kgm <sup>2</sup>	Measuring surface sound pressure level at 50 Hz $L_{pFA}$ dB(A)	Sound pressure level at 50 Hz $L_{WA}$ dB(A)
<b>8-pole, 750 rpm at 50 Hz, 900 rpm at 60 Hz, temperature class 155 (F), IP55 degree of protection</b>							
1LA6 106-8AB□□	1.6	3	1.9	13	0.0051	45	57
1LA6 107-8AB□□	1.8	3.3	2.1	13	0.0063	45	57
1LA6 113-8AB□□	1.8	3.7	2.1	13	0.013	49	61
1LA6 130-8AB□□	1.9	3.9	2.3	13	0.014	53	65
1LA6 133-8AB□□	2.1	4.1	2.4	13	0.019	53	65
1LA6 163-8AB□□	2.2	4.5	2.6	13	0.036	63	75
1LA6 164-8AB□□	2.3	4.7	2.7	13	0.046	63	75
1LA6 166-8AB□□	2.7	5.3	3	13	0.064	63	75
1LG4 186-8AB□□	1.7	4.2	2.1	13	0.17	65	78
1LG4 207-8AB□□	2.2	4.9	2.6	13	0.29	67	70
1LG4 220-8AB□□	2.3	5.5	2.7	13	0.48	57	70
1LG4 223-8AB□□	2.3	5.6	2.8	13	0.55	54	73
1LG4 253-8AB□□	2.3	5.5	2.6	13	0.84	55	73
1LG4 280-8AB□□	2.2	5	2.1	13	1.1	55	74
1LG4 283-8AB□□	2.2	5.1	2.1	13	1.4	58	74
1LG4 310-8AB□□	2.2	5.8	2.6	13	2.1	64	78
1LG4 313-8AB□□	2.2	5.7	2.6	13	2.5	64	78
1LG4 316-8AB□□	2.2	5.8	2.7	13	3.1	64	78
1LG4 317-8AB□□	2.4	6.1	2.8	13	3.9	64	78
1LG4 318-8AB□□	2.5	6.5	2.9	13	4.5	64	78

### Order No. supplements

Motor type	Penultimate position: Voltage code						Final position: Type of construction code						
	50 Hz		60 Hz		Without flange	With flange		With standard flange		With special flange			
	230 VΔ/400 VY	400 VΔ/690 VY	500 VY	500 VΔ	460 VY	460 VΔ	IM B3/6/7/8, IM V6 <sup>1)2)</sup>	IM B5, IM V3 <sup>1)3)</sup>	IM V1 With protective cover <sup>1)3)4)</sup>	IM B 35 IM V19 <sup>1)</sup>	IM B14, IM B34	IM B14, IM V19 <sup>1)</sup>	
	<b>1</b>	<b>6</b>	<b>3</b>	<b>5</b>	<b>1</b>	<b>6</b>	<b>0</b>	<b>1</b>	<b>4</b>	<b>6</b>	<b>2</b>	<b>7</b>	<b>3</b>
1LA6 10...□□	○	○	○	○	○	○	□	✓	✓	✓	✓	✓	✓
1LA6 11...□□	○	○	○	○	○	○	□	✓	✓	✓	✓	✓	✓
1LA6 13...□□	○	○	○	○	○	○	□	✓	✓	✓	✓	✓	✓
1LA6 16...□□	○	○	○	○	○	○	□	✓	✓	✓	✓	✓	✓
1LG4 18...□□	○	○	○	○	○	○	□	✓ <sup>5)</sup>	✓	✓	–	–	–
1LG4 20...□□	○	○	○	○	○	○	□	✓ <sup>5)</sup>	✓	✓	–	–	–
1LG4 22...□□	○	○	○	○	○	○	□	✓ <sup>5)</sup>	✓	✓	–	–	–
1LG4 25...□□	○	○	○	○	○	○	□	✓ <sup>5)</sup>	✓	✓	–	–	–
1LG4 28...□□	○	○	○	○	○	○	□	✓ <sup>5)</sup>	✓	✓	–	–	–
1LG4 310...□□	○	○	○	○	○	○	□	✓ <sup>5)</sup>	✓	✓	–	–	–
1LG4 313...□□	○	○	○	○	○	○	□	✓ <sup>5)</sup>	✓	✓	–	–	–
1LG4 316...□□	–	○	–	○	–	○	□ <sup>6)</sup>	–	✓	✓	–	–	–
1LG4 317...□□	–	○	–	○	–	○	□ <sup>6)</sup>	–	✓	✓	–	–	–
1LG4 318...□□	–	○	–	○	–	○	□ <sup>6)</sup>	–	✓	✓	–	–	–

- Standard version
- Without additional charge
- ✓ With additional charge
- Not possible

Order other voltages with voltage code **9** in the penultimate position and the corresponding order code (see "Special versions" in the "Selection and ordering data" under "Voltages").

Order other types of construction with type of construction code **9** in the final position and the corresponding order code (see "Special versions" in the "Selection and ordering data" under "Types of construction").

- 1) The following applies for explosion-proof motors: In the case of the types of construction with shaft extension down, the version "with protective cover" is required. For types of construction with shaft extension pointing upwards, a suitable cover must be implemented to prevent small parts from falling into the fan cover (see the standard IEC/EN 60079-0). The cover must not block the cooling air-flow.
- 2) If motors 1LG4 183... to 1LG4 318... (motor series 1LG4 frame sizes 180 M to 315 L) in types of construction with feet IM B6, IM B7 or IM V6 are fixed to the wall, it is recommended that the motor feet are supported.
- 3) 1LG4 220... to 1LG4 318... motors (motor series 225 S to 315 L) are supplied with two screw-in eyebolts in accordance with IM B5, whereby one can be relocated in accordance with IM V1 or IM V3. It is important to note that stress must not be applied perpendicular to the ring plane.
- 4) The "Second shaft extension" option, order code **K16** is not possible.
- 5) Type of construction IM V3 is only possible using type of construction code **9** and order code **M1G**.
- 6) Type of construction IM V6 is only possible using type of construction code **9** and order code **M1E**.

# IEC Squirrel-Cage Motors

## Explosion-proof motors

Self-ventilated, in Zones 2, 21, 22 with type of prot. "n" or prot. against dust explosions – Cast-iron series 1LG6

### Selection and ordering data

Rated output at 50 Hz $P_{\text{rated}}$ kW	Frame size FS	Operating values at rated output						Order No. For Order No. supplements for voltage, type of construction and explosion protection zones according to ATEX, see tables below	Price	Weight IM B3 type of construction approx. m kg
		Rated speed at 50 Hz $n_{\text{rated}}$ rpm	Rated torque at 50 Hz $T_{\text{rated}}$ Nm	Efficiency at 50 Hz 4/4-load $\eta_{\text{rated}}$ %	Efficiency at 50 Hz 3/4-load $\eta_{\text{rated}}$ %	Power factor at 50 Hz 4/4-load $\cos\phi_{\text{rated}}$	Rated current at 400 V, 50 Hz $I_{\text{rated}}$ A			
<b>2-pole, 3000 rpm at 50 Hz, temperature class 155 (F), IP55 degree of protection, "High Efficiency"</b>										
22	180 M	2955	71	94.1	94.5	0.88	38.5 <sup>1)</sup>	<b>1LG6 183-2AA□□</b>		180
30	200 L	2960	97	93.5	93.4	0.88	53 <sup>1)</sup>	<b>1LG6 206-2AA□□</b>		225
37	200 L	2960	119	94.1	94	0.89	64 <sup>1)</sup>	<b>1LG6 207-2AA□□</b>		255
45	225 M	2965	145	94.9	95.1	0.89	77 <sup>1)</sup>	<b>1LG6 223-2AA□□</b>		330
55	250 M	2975	177	95.3	95.3	0.9	93	<b>1LG6 253-2AA□□</b>		420
75	280 S	2975	241	95.2	95.2	0.89	128 <sup>1)</sup>	<b>1LG6 280-2AB□□</b>		530
90	280 M	2978	289	95.6	95.7	0.9	150 <sup>1)</sup>	<b>1LG6 283-2AB□□</b>		615
110	315 S	2982	352	95.8	95.7	0.91	182 <sup>1)</sup>	<b>1LG6 310-2AB□□</b>		790
132	315 M	2982	423	96	95.9	0.91	220 <sup>1)</sup>	<b>1LG6 313-2AB□□</b>		915
160	315 L	2982	512	96.4	96.4	0.92	260 <sup>2)</sup>	<b>1LG6 316-2AB□□</b>		1055
200	315 L	2982	641	96.5	96.5	0.93	320 <sup>2)</sup>	<b>1LG6 317-2AB□□</b>		1245
<b>4-pole, 1500 rpm at 50 Hz, temperature class 155 (F), IP55 degree of protection, "High Efficiency"</b>										
18.5	180 M	1470	120	92.6	93.2	0.83	34.5 <sup>1)</sup>	<b>1LG6 183-4AA□□</b>		155
22	180 L	1470	143	93.2	93.5	0.84	40.5 <sup>1)</sup>	<b>1LG6 186-4AA□□</b>		180
30	200 L	1470	195	93.3	93.4	0.85	55 <sup>1)</sup>	<b>1LG6 207-4AA□□</b>		225
37	225 S	1480	239	94	94.4	0.85	67 <sup>1)</sup>	<b>1LG6 220-4AA□□</b>		290
45	225 M	1480	290	94.5	94.7	0.85	81 <sup>1)</sup>	<b>1LG6 223-4AA□□</b>		330
55	250 M	1485	354	95.1	95.3	0.87	96	<b>1LG6 253-4AA□□</b>		460
75	280 S	1485	482	95.1	95.2	0.87	130 <sup>1)</sup>	<b>1LG6 280-4AA□□</b>		575
90	280 M	1486	578	95.4	95.5	0.86	158 <sup>1)</sup>	<b>1LG6 283-4AA□□</b>		675
110	315 S	1488	706	95.9	96	0.87	190 <sup>1)</sup>	<b>1LG6 310-4AA□□</b>		810
132	315 M	1488	847	96.1	96.2	0.88	225 <sup>1)</sup>	<b>1LG6 313-4AA□□</b>		965
160	315 L	1490	1026	96.3	96.4	0.88	275 <sup>2)</sup>	<b>1LG6 316-4AA□□</b>		1105
200	315 L	1490	1282	96.4	96.5	0.88	340 <sup>2)</sup>	<b>1LG6 317-4AA□□</b>		1305

### Special versions according to ATEX

Motor type	Frame size	Zone 2		VIK (includes Zone 2) <sup>3)</sup>		Zone 21		Zone 22	
		Mains-fed operation Order code <b>M72</b>	Converter-fed operation (FC) Order code <b>M73</b>	Mains-fed operation Order code <b>K30</b>	Converter-fed operation (FC) On request	Mains-fed operation Order code <b>M34</b>	Converter-fed operation (FC) Order code <b>M38</b>	Mains-fed operation Order code <b>M35</b>	Converter-fed operation (FC) Order code <b>M39</b>
<b>1LG6</b>	180	✓	✓	✓	✓	✓	✓	✓	✓
	200	✓	✓	✓	✓	✓	✓	✓	✓
	225	✓	✓	✓	✓	✓	✓	✓	✓
	250	✓	✓	✓	✓	✓	✓	✓	✓
	280	✓	✓	✓	✓	✓	✓	✓	✓
	315	✓	✓	✓	✓	✓	✓	✓	✓

✓ With additional charge

The motors can also be ordered in design for Zones 2 and 22 for non-conducting dust (IP55):

Mains-fed operation – order code **M74**

Converter-fed operation with derating – order code **M75**

See "Special versions" in the "Selection and ordering data" under "Options".

The motors can also be used for 60 Hz according to EPACT, see Pages 4/74 to 4/79.

<sup>1)</sup> For connection to 230 V, parallel feeders are necessary (see the "Introduction" section, "Connection, circuit and connection box").

<sup>2)</sup> For connection to 400 V, parallel feeders are necessary (see the "Introduction" section, "Connection, circuit and connection box").

<sup>3)</sup> If the marking Ex nA II is required in addition to VIK on the rating plate, this must be ordered using order code **C27**. The VIK version is not possible in combination with Zone 21 and 22.

# IEC Squirrel-Cage Motors

## Explosion-proof motors

Self-ventilated, in Zones 2, 21, 22 with type of prot. "n" or prot. against dust explosions – Cast-iron series 1LG6

### Selection and ordering data (continued)

Order No.	Locked-rotor torque with direct starting torque	Locked-rotor current as multiple of rated current	Breakdown torque	Torque class	Moment of inertia	Noise at rated output	
	$T_{LR}/T_{rated}$	$I_{LR}/I_{rated}$	$T_B/T_{rated}$	CL	$J$ kgm <sup>2</sup>	Measuring surface sound pressure level at 50 Hz $L_{pFA}$ dB(A)	Sound pressure level at 50 Hz $L_{WA}$ dB(A)
<b>2-pole, 3000 rpm at 50 Hz, temperature class 155 (F), IP55 degree of protection, "High Efficiency"</b>							
1LG6 183-2AA□□	2.5	7.2	3.4	16	0.086	67	80
1LG6 206-2AA□□	2.4	7	3.3	16	0.15	71	84
1LG6 207-2AA□□	2.5	7.2	3.3	16	0.18	71	84
1LG6 223-2AA□□	2.5	7.3	3.2	16	0.27	71	84
1LG6 253-2AA□□	2.4	6.8	3	16	0.47	71	84
1LG6 280-2AB□□	2.5	7	3	13	0.83	73	86
1LG6 283-2AB□□	2.6	7.6	3.1	13	1	73	86
1LG6 310-2AB□□	2.4	6.9	2.8	13	1.4	76	89
1LG6 313-2AB□□	2.6	7.1	2.9	13	1.6	76	89
1LG6 316-2AB□□	2.5	7.1	2.9	13	2.1	76	89
1LG6 317-2AB□□	2.5	6.9	2.8	13	2.5	76	89
<b>4-pole, 1500 rpm at 50 Hz, temperature class 155 (F), IP55 degree of protection, "High Efficiency"</b>							
1LG6 183-4AA□□	2.5	6.4	3	16	0.12	60	73
1LG6 186-4AA□□	2.5	6.7	3.1	16	0.14	60	73
1LG6 207-4AA□□	2.6	6.7	3.3	16	0.23	62	75
1LG6 220-4AA□□	2.7	6.8	3	16	0.4	60	73
1LG6 223-4AA□□	2.8	6.9	3	16	0.49	60	73
1LG6 253-4AA□□	2.6	7.5	3	16	0.86	65	78
1LG6 280-4AA□□	2.5	6.8	2.9	16	1.4	67	80
1LG6 283-4AA□□	2.7	7.5	3.1	16	1.7	67	80
1LG6 310-4AA□□	2.7	7.1	2.9	16	2.3	68	82
1LG6 313-4AA□□	2.7	7.3	2.9	16	2.9	68	82
1LG6 316-4AA□□	3	7.4	3	16	3.5	68	82
1LG6 317-4AA□□	3.2	7.6	3	16	4.2	68	82

### Order No. supplements

Motor type	Penultimate position: Voltage code				Final position: Type of construction code						
	50 Hz				Without flange	With flange			With standard flange		With special flange
	230 VΔ/400 VY	400 VΔ/690 VY	500 VY	500 VΔ	IM B3/6/7/8, IM V6 <sup>1)2)</sup>	IM B5 <sup>1)3)</sup> , IM V3 <sup>4)</sup>	IM V1 with protective cover <sup>1)3)5)</sup>	IM B35	IM B14, IM V19 <sup>1)</sup>	IM B34	IM B14, IM V19 <sup>1)</sup>
	1	6	3	5	0	1	4	6	2	7	3
1LG6 18 - . . . . □□	○	○	○	○	□	✓	✓	✓	-	-	-
1LG6 20 - . . . . □□	○	○	○	○	□	✓	✓	✓	-	-	-
1LG6 22 - . . . . □□	○	○	○	○	□	✓	✓	✓	-	-	-
1LG6 25 - . . . . □□	○	○	○	○	□	✓	✓	✓	-	-	-
1LG6 28 - . . . . □□	○	○	○	○	□	✓	✓	✓	-	-	-
1LG6 310 - . . . □□	○	○	○	○	□	✓	✓	✓	-	-	-
1LG6 313 - . . . □□	○	○	○	○	□	✓	✓	✓	-	-	-
1LG6 316 - . . . □□	-	○	-	○	□ <sup>6)</sup>	-	✓ <sup>7)</sup>	✓	-	-	-
1LG6 317 - . . . □□	-	○	-	○	□ <sup>6)</sup>	-	✓ <sup>7)</sup>	✓	-	-	-

□ Standard version  
○ Without additional charge

✓ With additional charge  
- Not possible

Order other voltages with voltage code **9** in the penultimate position and the corresponding order code (see "Special versions" in the "Selection and ordering data" under "Voltages").

Order other types of construction with type of construction code **9** in the final position and the corresponding order code (see "Special versions" in the "Selection and ordering data" under "Types of construction").

- The following applies for explosion-proof motors: In the case of the types of construction with shaft extension down, the version "with protective cover" is required. For types of construction with shaft extension pointing upwards, a suitable cover must be implemented to prevent small parts from falling into the fan cover (see the standard IEC/EN 60079-0). The cover must not block the cooling air-flow.
- If motors 1LG6 183-... to 1LG6 318-... (motor series 1LG6 frame sizes 180 M to 315 L) in types of construction with feet IM B6, IM B7 or IM V6 are fixed to the wall, it is recommended that the motor feet are supported.

- 1LG6 220-... to 1LG6 318-... motors (motor series 1LG6 frame sizes 225 S to 315 L) are supplied with two screw-in eyebolts in accordance with IM B5, whereby one can be relocated in accordance with IM V1 or IM V3. It is important to note that stress must not be applied perpendicular to the ring plane.
- Type of construction IM V3 is only possible using type of construction code **9** and order code **M1G**.
- The "Second shaft extension" option, order code **K16** is not possible.
- Type of construction IM V6 is only possible using type of construction code **9** and order code **M1E**.
- 2-pole motors in 60 Hz version available on request.

# IEC Squirrel-Cage Motors

## Explosion-proof motors

Self-ventilated, in Zones 2, 21, 22 with type of prot. "n" or prot. against dust explosions – Cast-iron series 1LG6

### Selection and ordering data (continued)

Rated output at 50 Hz $P_{\text{rated}}$ kW	Frame size FS	Operating values at rated output						Order No. For Order No. supplements for voltage, type of construction and explosion protection zones according to ATEX, see tables below	Price	Weight IM B3 type of construction approx. $m$ kg
		Rated speed at 50 Hz $n_{\text{rated}}$ rpm	Rated torque at 50 Hz $T_{\text{rated}}$ Nm	Efficiency at 50 Hz 4/4-load $\eta_{\text{rated}}$ %	Efficiency at 50 Hz 3/4-load $\eta_{\text{rated}}$ %	Power factor at 50 Hz 4/4-load $\cos\phi_{\text{rated}}$	Rated current at 400 V, 50 Hz $I_{\text{rated}}$ A			
<b>6-pole, 1000 rpm at 50 Hz, temperature class 155 (F), IP55 degree of protection, "High Efficiency"</b>										
15	180 L	975	147	90.9	91.7	0.81	29.5	<b>1LG6 186-6AA□□</b>		175
18.5	200 L	978	181	91.2	91.8	0.81	36	<b>1LG6 206-6AA□□</b>		210
22	200 L	978	215	91.9	92.5	0.82	42	<b>1LG6 207-6AA□□</b>		240
30	225 M	980	292	93.2	93.7	0.83	56 <sup>1)</sup>	<b>1LG6 223-6AA□□</b>		325
37	250 M	985	359	93.7	94.1	0.83	69	<b>1LG6 253-6AA□□</b>		405
45	280 S	988	435	94.4	94.6	0.85	81	<b>1LG6 280-6AA□□</b>		520
55	280 M	988	532	94.6	94.8	0.85	99	<b>1LG6 283-6AA□□</b>		570
75	315 S	990	723	95	95	0.83	138	<b>1LG6 310-6AA□□</b>		760
90	315 M	990	868	95.3	95.4	0.85	160 <sup>1)</sup>	<b>1LG6 313-6AA□□</b>		935
110	315 L	990	1061	95.6	95.7	0.85	196	<b>1LG6 316-6AA□□</b>		1010
132	315 L	990	1273	95.8	95.8	0.85	235	<b>1LG6 317-6AA□□</b>		1180
160	315 L	990	1543	95.8	95.9	0.86	280 <sup>2)</sup>	<b>1LG6 318-6AA□□</b>		1245
<b>8-pole, 750 rpm at 50 Hz, temperature class 155 (F), IP55 degree of protection, "High Efficiency"</b>										
11	180 L	725	145	88.7	89.6	0.76	23.5	<b>1LG6 186-8AB□□</b>		165
15	200 L	725	198	89.3	89.8	0.8	30.5	<b>1LG6 207-8AB□□</b>		235
18.5	225 S	730	242	91.1	91.8	0.81	36	<b>1LG6 220-8AB□□</b>		295
22	225 M	730	288	91.6	92.1	0.81	43	<b>1LG6 223-8AB□□</b>		335
30	250 M	735	390	92.8	93.3	0.82	57	<b>1LG6 253-8AB□□</b>		435
37	280 S	738	479	93.1	93.3	0.81	71	<b>1LG6 280-8AB□□</b>		510
45	280 M	738	582	93.7	94	0.81	86	<b>1LG6 283-8AB□□</b>		560
55	315 S	740	710	94.3	94.4	0.82	102	<b>1LG6 310-8AB□□</b>		750
75	315 M	740	968	94.5	94.7	0.83	138	<b>1LG6 313-8AB□□</b>		840
90	315 L	740	1161	94.7	95.1	0.84	164	<b>1LG6 316-8AB□□</b>		1005
110	315 L	740	1420	94.8	95.1	0.84	200	<b>1LG6 317-8AB□□</b>		1100
132	315 L	740	1704	94.9	95.2	0.84	240	<b>1LG6 318-8AB□□</b>		1270

### Special versions according to ATEX

Motor type	Zone 2		VIK (includes Zone 2) <sup>3)</sup>		Zone 21		Zone 22		
	Frame size	Mains-fed operation Order code <b>M72</b>	Converter-fed operation (FC) Order code <b>M73</b>	Mains-fed operation Order code <b>K30</b>	Converter-fed operation (FC) On request	Mains-fed operation Order code <b>M34</b>	Converter-fed operation (FC) Order code <b>M38</b>	Mains-fed operation Order code <b>M35</b>	Converter-fed operation (FC) Order code <b>M39</b>
<b>1LG6</b>	180	✓	✓	✓	✓	✓	✓	✓	✓
	200	✓	✓	✓	✓	✓	✓	✓	✓
	225	✓	✓	✓	✓	✓	✓	✓	✓
	250	✓	✓	✓	✓	✓	✓	✓	✓
	280	✓	✓	✓	✓	✓	✓	✓	✓
315	✓	✓	✓	✓	✓	✓	✓	✓	

✓ With additional charge

The motors can also be ordered in design for Zones 2 and 22 for non-conducting dust (IP55):

Mains-fed operation – order code **M74**

Converter-fed operation with derating – order code **M75**

See "Special versions" in the "Selection and ordering data" under "Options".

The motors can also be used for 60 Hz according to EPACT, see Pages 4/74 to 4/79.

<sup>1)</sup> For connection to 230 V, parallel feeders are necessary (see the "Introduction" section, "Connection, circuit and connection box").

<sup>2)</sup> For connection to 400 V, parallel feeders are necessary (see the "Introduction" section, "Connection, circuit and connection box").

<sup>3)</sup> If the marking Ex nA II is required in addition to VIK on the rating plate, this must be ordered using order code **C27**. The VIK version is not possible in combination with Zone 21 and 22.

# IEC Squirrel-Cage Motors

## Explosion-proof motors

Self-ventilated, in Zones 2, 21, 22 with type of prot. "n" or prot. against dust explosions – Cast-iron series 1LG6

### Selection and ordering data (continued)

Order No.	Locked-rotor torque with direct starting torque	Locked-rotor current as multiple of rated current	Breakdown torque	Torque class	Moment of inertia	Noise at rated output	
	$T_{LR}/T_{rated}$	$I_{LR}/I_{rated}$	$T_B/T_{rated}$	CL	$J$ kgm <sup>2</sup>	Measuring surface sound pressure level at 50 Hz $L_{pFA}$ dB(A)	Sound pressure level at 50 Hz $L_{WA}$ dB(A)
<b>6-pole, 1000 rpm at 50 Hz, temperature class 155 (F), IP55 degree of protection, "High Efficiency"</b>							
1LG6 186-6AA□□	2.4	5.5	2.5	16	0.2	56	69
1LG6 206-6AA□□	2.4	5.6	2.4	16	0.29	59	72
1LG6 207-6AA□□	2.4	5.6	2.4	16	0.36	59	72
1LG6 223-6AA□□	2.8	6.5	2.9	16	0.63	59	72
1LG6 253-6AA□□	2.9	6.8	2.5	16	0.93	59	72
1LG6 280-6AA□□	3	6.8	2.7	16	1.4	58	71
1LG6 283-6AA□□	3.3	7.3	2.9	16	1.6	58	71
1LG6 310-6AA□□	2.8	7.3	3	16	2.5	61	74
1LG6 313-6AA□□	2.7	7.3	2.9	16	3.2	61	74
1LG6 316-6AA□□	2.9	7.4	2.9	16	4	61	74
1LG6 317-6AA□□	3.1	7.8	3.1	16	4.7	61	74
1LG6 318-6AA□□	3.2	7.8	3.1	16	5.4	64	77
<b>8-pole, 750 rpm at 50 Hz, temperature class 155 (F), IP55 degree of protection, "High Efficiency"</b>							
1LG6 186-8AB□□	1.7	4.6	2.2	13	0.21	62	75
1LG6 207-8AB□□	2.3	5.3	2.6	13	0.37	62	75
1LG6 220-8AB□□	2.3	5.6	2.6	13	0.55	54	67
1LG6 223-8AB□□	2.4	5.8	2.8	13	0.66	58	71
1LG6 253-8AB□□	2.5	6	2.8	13	1.1	57	70
1LG6 280-8AB□□	2.3	5.7	2.3	13	1.4	58	71
1LG6 283-8AB□□	2.6	6.1	2.5	13	1.6	58	71
1LG6 310-8AB□□	2.5	6.3	2.9	13	2.5	64	77
1LG6 313-8AB□□	2.5	6.7	2.9	13	3.1	58	72
1LG6 316-8AB□□	2.4	6.3	2.8	13	3.9	64	77
1LG6 317-8AB□□	2.4	6.4	2.6	13	4.5	64	77
1LG6 318-8AB□□	2.5	6.7	2.9	13	5.3	64	77

### Order No. supplements

Motor type	Penultimate position: Voltage code				Final position: Type of construction code							
	50 Hz				Without flange	With flange			With standard flange		With special flange	
	230 VΔ/400 VY	400 VΔ/690 VY	500 VY	500 VΔ	IM B3/6/7/8, IM V6 <sup>1)2)</sup>	IM B5 <sup>1)3)</sup> , IM V3 <sup>4)</sup>	IM V1 with protective cover <sup>1)3)5)</sup>	IM B35	IM B14, <sup>1)</sup> IM V19 <sup>1)</sup>	IM B34	IM B14, <sup>1)</sup> IM V19 <sup>1)</sup>	
	<b>1</b>	<b>6</b>	<b>3</b>	<b>5</b>	<b>0</b>	<b>1</b>	<b>4</b>	<b>6</b>	<b>2</b>	<b>7</b>	<b>3</b>	
1LG6 18 - ... □□	○	○	○	○	□	✓	✓	✓	-	-	-	
1LG6 20 - ... □□	○	○	○	○	□	✓	✓	✓	-	-	-	
1LG6 22 - ... □□	○	○	○	○	□	✓	✓	✓	-	-	-	
1LG6 25 - ... □□	○	○	○	○	□	✓	✓	✓	-	-	-	
1LG6 28 - ... □□	○	○	○	○	□	✓	✓	✓	-	-	-	
1LG6 310 - ... □□	○	○	○	○	□	✓	✓	✓	-	-	-	
1LG6 313 - ... □□	○	○	○	○	□	✓	✓	✓	-	-	-	
1LG6 316 - ... □□	-	○	-	○	□ <sup>6)</sup>	-	✓	✓	-	-	-	
1LG6 317 - ... □□												
1LG6 318 - ... □□												

- Standard version  
○ Without additional charge

- ✓ With additional charge  
- Not possible

Order other voltages with voltage code **9** in the penultimate position and the corresponding order code (see "Special versions" in the "Selection and ordering data" under "Voltages").

Order other types of construction with type of construction code **9** in the final position and the corresponding order code (see "Special versions" in the "Selection and ordering data" under "Types of construction").

- 1) The following applies for explosion-proof motors: In the case of the types of construction with shaft extension down, the version "with protective cover" is required. For types of construction with shaft extension pointing upwards, a suitable cover must be implemented to prevent small parts from falling into the fan cover (see the standard IEC/EN 60079-0). The cover must not block the cooling air-flow.
- 2) If motors 1LG6 183-... to 1LG6 318-... (motor series 1LG6 frame sizes 180 M to 315 L) in types of construction with feet IM B6, IM B7 or IM V6 are fixed to the wall, it is recommended that the motor feet are supported.

- 3) 1LG6 220-... to 1LG6 318-... motors (motor series 1LG6 frame sizes 225 S to 315 L) are supplied with two screw-in eyebolts in accordance with IM B5, whereby one can be relocated in accordance with IM V1 or IM V3. It is important to note that stress must not be applied perpendicular to the ring plane.
- 4) Type of construction IM V3 is only possible using type of construction code **9** and order code **M1G**.
- 5) The "Second shaft extension" option, order code **K16** is not possible.
- 6) Type of construction IM V6 is only possible using type of construction code **9** and order code **M1E**.

# IEC Squirrel-Cage Motors

## Explosion-proof motors

Self-ventilated, in Zones 2, 21, 22 with type of prot. "n" or prot. against dust explosions – Cast-iron series 1LG6

### Selection and ordering data

Rated output at 60 Hz $P_{\text{rated}}$ HP	Frame size FS	Operating values at rated output						Order No.	Price	Weight IM B3 type of construction approx. $m$ kg
		Rated speed at 60 Hz $n_{\text{rated}}$ rpm	Rated torque at 60 Hz $T_{\text{rated}}$ Nm	EPACT with CC No. CC 032A	Nominal efficiency at 60 Hz $\eta_{\text{rated}}$ %	Power factor at 60 Hz 4/4-load $\cos\phi_{\text{rated}}$	Rated current at 460 V, 60 Hz $I_{\text{rated}}$ A			
<b>2-pole, 3600 rpm at 60 Hz, temperature class 155 (F), IP55 degree of protection, for use in the North American market according to EPACT</b>										
30	180 M	3560	60	Yes	93	0.88	34	<b>1LG6 183-2AA□□</b>		180
40	200 L	3565	80	Yes	91.7	0.88	46	<b>1LG6 206-2AA□□</b>		225
50	200 L	3565	100	Yes	92.4	0.89	57	<b>1LG6 207-2AA□□</b>		255
60	225 M	3570	120	Yes	93.6	0.89	67	<b>1LG6 223-2AA□□</b>		330
75	225 M	3570	150	Yes	94.5	0.9	83	<b>1LG6 228-2AA□□</b> <sup>1)</sup>		390
75	250 M	3578	149	No	93.6	0.89	84	<b>1LG6 253-2AA□□</b>		420
100	250 M	3580	199	Yes	94.1	0.89	112	<b>1LG6 258-2AA□□</b> <sup>1)</sup>		470
100	280 S	3580	199	No	95	0.89	110	<b>1LG6 280-2AB□□</b>		530
125	280 M	3580	249	Yes	95	0.9	136	<b>1LG6 283-2AB□□</b>		615
150	280 M	3580	299	Yes	95	0.9	164	<b>1LG6 288-2AA□□</b> <sup>1)</sup>		660
150	315 S	3585	298	Yes	94.5	0.91	164	<b>1LG6 310-2AB□□</b>		790
175	315 M	3586	348	Yes	95	0.91	190	<b>1LG6 313-2AB□□</b>		915
200	315 L	3588	397	Yes	95.4	0.91	215	<b>1LG6 316-2AB□□</b>		1055
250	315 L	3588	496	No	95.4	0.93	265	<b>1LG6 317-2AB□□</b>		1245
300	315 L	3591	595	No	95.4	0.92	320	<b>1LG6 318-2AA□□</b> <sup>1)</sup>		1330

### Special versions according to ATEX

Motor type	Frame size	Zone 2		VIK (includes Zone 2) <sup>2)</sup>		Zone 21		Zone 22	
		Mains-fed operation Order code M72	Converter-fed operation (FC) Order code M73	Mains-fed operation Order code K30	Converter-fed operation (FC) On request	Mains-fed operation Order code M34	Converter-fed operation (FC) Order code M38	Mains-fed operation Order code M35	Converter-fed operation (FC) Order code M39
<b>1LG6</b>	180	✓	✓	✓	✓	✓	✓	✓	✓
	200	✓	✓	✓	✓	✓	✓	✓	✓
	225	✓	✓	✓	✓	✓	✓	✓	✓
	250	✓	✓	✓	✓	✓	✓	✓	✓
	280	✓	✓	✓	✓	✓	✓	✓	✓
	315	✓	✓	✓	✓	✓	✓	✓	✓

✓ With additional charge

The motors can also be ordered in design for Zones 2 and 22 for non-conducting dust (IP55):  
Mains-fed operation – order code **M74**  
Converter-fed operation with derating – order code **M75**  
See "Special versions" in the "Selection and ordering data" under "Options".

**The motors can also be used for 50 Hz "High Efficiency", see Pages 4/70 to 4/73.**

<sup>1)</sup> Only 60 Hz data according to EPACT on the rating plate.

<sup>2)</sup> If the marking Ex nA II is required in addition to VIK on the rating plate, this must be ordered using order code **C27**. The VIK version is not possible in combination with Zone 21 and 22.

# IEC Squirrel-Cage Motors

## Explosion-proof motors

Self-ventilated, in Zones 2, 21, 22 with type of prot. "n" or prot. against dust explosions – Cast-iron series 1LG6

### Selection and ordering data (continued)

Order No.	Locked-rotor torque	Locked-rotor current	Breakdown torque	Torque class	Moment of inertia	Noise at rated output	
	with direct starting torque	as multiple of rated current	torque			Measuring surface sound pressure level at 60 Hz	Sound pressure level at 60 Hz
	$T_{LR}/T_{rated}$	$I_{LR}/I_{rated}$	$T_B/T_{rated}$	CL	$J$ kgm <sup>2</sup>	$L_{pFA}$ dB(A)	$L_{WA}$ dB(A)
<b>2-pole, 3600 rpm at 60 Hz, temperature class 155 (F), IP55 degree of protection, for use in the North American market according to EPACK</b>							
<b>1LG6 183-2AA□□</b>	2.7	7.9	3.7	16	0.086	72	85
<b>1LG6 206-2AA□□</b>	2.7	7.8	3.7	16	0.15	75	88
<b>1LG6 207-2AA□□</b>	2.8	7.8	3.7	16	0.18	75	88
<b>1LG6 223-2AA□□</b>	2.8	8.3	3.6	16	0.27	74	87
<b>1LG6 228-2AA□□</b>	3.3	8.7	3.7	16	0.32	74	87
<b>1LG6 253-2AA□□</b>	2.7	7.5	3.2	16	0.47	75	88
<b>1LG6 258-2AA□□</b>	2.8	8.4	3.5	16	0.57	79	92
<b>1LG6 280-2AB□□</b>	2.8	7.9	3.4	13	0.83	77	90
<b>1LG6 283-2AB□□</b>	2.9	8.3	3.4	13	1	77	90
<b>1LG6 288-2AA□□</b>	3.1	8.5	3.6	16	1.16	77	90
<b>1LG6 310-2AB□□</b>	2.6	7.5	3.1	13	1.4	81	94
<b>1LG6 313-2AB□□</b>	3	8.3	3.3	13	1.6	81	94
<b>1LG6 316-2AB□□</b>	3	8.4	3.5	13	2.1	81	94
<b>1LG6 317-2AB□□</b>	3.2	8.6	3.4	13	2.5	81	94
<b>1LG6 318-2AA□□</b>	4.1	10	3.9	16	2.74	83	96

### Order No. supplements

Motor type	Penultimate position: Voltage code		Final position: Type of construction code				With standard flange		With special flange
	60 Hz	460 VΔ	Without flange	With flange	IM V1 with protective cover	IM B35	IM B14, IM V19 <sup>1)</sup>	IM B34	IM B14, IM V19 <sup>1)</sup>
	(see "Introduction" for outputs at 60 Hz)		IM B3/6/7/8, IM V6 <sup>1)2)</sup>	IM B5, IM V3 <sup>1)3)4)</sup>	IM V1 with protective cover <sup>1)3)5)</sup>				
	<b>1</b>	<b>6</b>	<b>0</b>	<b>1</b>	<b>4</b>	<b>6</b>	<b>2</b>	<b>7</b>	<b>3</b>
<b>1LG6 18 - . . . . □□</b>	○	○	□	✓	✓	✓	-	-	-
<b>1LG6 20 - . . . . □□</b>	○	○	□	✓	✓	✓	-	-	-
<b>1LG6 22 - . . . . □□</b>	○	○	□	✓	✓	✓	-	-	-
<b>1LG6 25 - . . . . □□</b>	○	○	□	✓	✓	✓	-	-	-
<b>1LG6 28 - . . . . □□</b>	○	○	□	✓	✓	✓	-	-	-
<b>1LG6 310 - . . . . □□</b>	○	○	□	✓	✓	✓	-	-	-
<b>1LG6 313 - . . . . □□</b>	○	○	□	✓	✓	✓	-	-	-
<b>1LG6 316 - . . . . □□</b>	-	○	□ <sup>6)</sup>	-	✓ <sup>7)</sup>	✓	-	-	-
<b>1LG6 317 - . . . . □□</b>	-	○	□	-	✓	✓	-	-	-
<b>1LG6 318 - . . . . □□</b>	-	○	□	-	✓	✓	-	-	-

- Standard version
- Without additional charge
- ✓ With additional charge
- Not possible

Order other voltages with voltage code **9** in the penultimate position and the corresponding order code (see "Special versions" in the "Selection and ordering data" under "Voltages").

Order other types of construction with type of construction code **9** in the final position and the corresponding order code (see "Special versions" in the "Selection and ordering data" under "Types of construction").

- 1) The following applies for explosion-proof motors: In the case of the types of construction with shaft extension down, the version "with protective cover" is required. For types of construction with shaft extension pointing upwards, a suitable cover must be implemented to prevent small parts from falling into the fan cover (see the standard IEC/EN 60079-0). The cover must not block the cooling air-flow.
- 2) If motors 1LG6 183-... to 1LG6 318-... (motor series 1LG6 frame sizes 180 M to 315 L) in types of construction with feet IM B6, IM B7 or IM V6 are fixed to the wall, it is recommended that the motor feet are supported.

- 3) 1LG6 220-... to 1LG6 318-... motors (motor series 1LG6 frame sizes 225 S to 315 L) are supplied with two screw-in eyebolts in accordance with IM B5, whereby one can be relocated in accordance with IM V1 or IM V3. It is important to note that stress must not be applied perpendicular to the ring plane.
- 4) Type of construction IM V3 is only possible using type of construction code **9** and order code **M1G**.
- 5) The "Second shaft extension" option, order code **K16** is not possible.
- 6) Type of construction IM V6 is only possible using type of construction code **9** and order code **M1E**.
- 7) 2-pole motors in 60 Hz version available on request.

# IEC Squirrel-Cage Motors

## Explosion-proof motors

Self-ventilated, in Zones 2, 21, 22 with type of prot. “n” or prot. against dust explosions – Cast-iron series 1LG6

### Selection and ordering data (continued)

Rated output at 60 Hz $P_{\text{rated}}$ HP	Frame size FS	Operating values at rated output					Power factor at 60 Hz 4/4-load $\cos\phi_{\text{rated}}$	Rated current at 460 V, 60 Hz $I_{\text{rated}}$ A	Order No. For Order No. supplements for voltage, type of construction and explosion protection zones according to ATEX, see tables below	Price	Weight IM B3 type of construction approx. $m$ kg
		Rated speed at 60 Hz $n_{\text{rated}}$ rpm	Rated torque at 60 Hz $T_{\text{rated}}$ Nm	EPACT with CC No. CC 032A	Nominal efficiency at 60 Hz $\eta_{\text{rated}}$ %						
<b>4-pole, 1800 rpm at 60 Hz, temperature class 155 (F), IP55 degree of protection, for use in the North American market according to EPACT</b>											
25	180 M	1775	100	Yes	92.4	0.82	31	<b>1LG6 183-4AA□□</b>		155	
30	180 L	1775	120	Yes	92.4	0.83	36.5	<b>1LG6 186-4AA□□</b>		180	
40	200 L	1775	160	Yes	93	0.84	48	<b>1LG6 207-4AA□□</b>		225	
50	225 S	1785	199	No	93.6	0.84	60	<b>1LG6 220-4AA□□</b>		290	
60	225 M	1785	239	Yes	94.1	0.85	70	<b>1LG6 223-4AA□□</b>		330	
75	225 M	1785	299	Yes	94.1	0.85	88	<b>1LG6 228-4AA□□<sup>1)</sup></b>		355	
75	250 M	1790	298	No	94.5	0.86	86	<b>1LG6 253-4AA□□</b>		460	
100	250 M	1788	398	Yes	94.5	0.86	116	<b>1LG6 258-4AA□□<sup>1)</sup></b>		495	
100	280 S	1788	398	No	94.5	0.86	114	<b>1LG6 280-4AA□□</b>		575	
125	280 M	1790	497	Yes	95	0.86	144	<b>1LG6 283-4AA□□</b>		675	
150	280 M	1788	598	Yes	95	0.86	172	<b>1LG6 288-4AA□□<sup>1)</sup></b>		710	
150	315 S	1791	596	Yes	95	0.87	170	<b>1LG6 310-4AA□□</b>		810	
175	315 M	1791	696	Yes	95.4	0.87	198	<b>1LG6 313-4AA□□</b>		965	
200	315 L	1792	795	Yes	95.4	0.87	225	<b>1LG6 316-4AA□□</b>		1105	
250	315 L	1792	994	No	95.8	0.87	280	<b>1LG6 317-4AA□□</b>		1305	
300	315 L	1792	1193	No	95.8	0.87	335	<b>1LG6 318-4AA□□<sup>1)</sup></b>		1345	

### Special versions according to ATEX

Motor type	Zone 2		VIK (includes Zone 2) <sup>2)</sup>		Zone 21		Zone 22		
	Frame size	Mains-fed operation Order code <b>M72</b>	Converter-fed operation (FC) Order code <b>M73</b>	Mains-fed operation Order code <b>K30</b>	Converter-fed operation (FC) On request	Mains-fed operation Order code <b>M34</b>	Converter-fed operation (FC) Order code <b>M38</b>	Mains-fed operation Order code <b>M35</b>	Converter-fed operation (FC) Order code <b>M39</b>
<b>1LG6</b>	180	✓	✓	✓	✓	✓	✓	✓	✓
	200	✓	✓	✓	✓	✓	✓	✓	✓
	225	✓	✓	✓	✓	✓	✓	✓	✓
	250	✓	✓	✓	✓	✓	✓	✓	✓
	280	✓	✓	✓	✓	✓	✓	✓	✓
	315	✓	✓	✓	✓	✓	✓	✓	✓

✓ With additional charge

The motors can also be ordered in design for Zones 2 and 22 for non-conducting dust (IP55):

Mains-fed operation – order code **M74**

Converter-fed operation with derating – order code **M75**

See “Special versions” in the “Selection and ordering data” under “Options”.

The motors can also be used for 50 Hz “High Efficiency”, see Pages 4/70 to 4/73.

<sup>1)</sup> Only 60 Hz data according to EPACT on the rating plate.

<sup>2)</sup> If the marking Ex nA II is required in addition to VIK on the rating plate, this must be ordered using order code **C27**. The VIK version is not possible in combination with Zone 21 and 22.



# IEC Squirrel-Cage Motors

## Explosion-proof motors

Self-ventilated, in Zones 2, 21, 22 with type of prot. "n" or prot. against dust explosions – Cast-iron series 1LG6

### Selection and ordering data (continued)

Order No.	Locked-rotor torque with direct starting torque	Locked-rotor current as multiple of rated current	Breakdown torque	Torque class	Moment of inertia	Noise at rated output	
	$T_{LR}/T_{rated}$	$I_{LR}/I_{rated}$	$T_B/T_{rated}$	CL	$J$ kgm <sup>2</sup>	Measuring surface sound pressure level at 60 Hz $L_{pFA}$ dB(A)	Sound pressure level at 60 Hz $L_{WA}$ dB(A)
<b>4-pole, 1800 rpm at 60 Hz, temperature class 155 (F), IP55 degree of protection, for use in the North American market according to EPACT</b>							
1LG6 183-4AA□□	2.9	7.1	3.3	16	0.12	65	78
1LG6 186-4AA□□	2.8	7.4	3.4	16	0.14	65	78
1LG6 207-4AA□□	3	7.7	3.7	16	0.23	66	79
1LG6 220-4AA□□	3.1	7.5	3.4	16	0.4	65	78
1LG6 223-4AA□□	3.3	7.9	3.5	16	0.49	65	78
1LG6 228-4AA□□	3	7.8	3.3	16	0.66	64	78
1LG6 253-4AA□□	2.9	8.2	3.4	16	0.86	68	81
1LG6 258-4AA□□	3	8.1	3.3	16	0.99	72	86
1LG6 280-4AA□□	2.9	7.6	3.2	16	1.4	71	84
1LG6 283-4AA□□	3	8.2	3.4	16	1.7	71	84
1LG6 288-4AA□□	3.1	8.4	3.5	16	1.88	71	85
1LG6 310-4AA□□	3.1	7.8	3.2	16	2.3	75	88
1LG6 313-4AA□□	3.2	8.4	3.3	16	2.9	75	88
1LG6 316-4AA□□	3.7	9	3.6	16	3.5	75	88
1LG6 317-4AA□□	4	9.1	3.7	16	4.2	75	88
1LG6 318-4AA□□	4	9.3	3.7	16	4.5	81	94

### Order No. supplements

Motor type	Penultimate position: Voltage code		Final position: Type of construction code						
	60 Hz 460 VY 460 VΔ (see "Introduction" for outputs at 60 Hz)		Without flange IM B3/6/7/8, IM V6 <sup>1)2)</sup>	With flange IM B5, IM V3 <sup>1)3)4)</sup>	IM V1 with protective cover <sup>1)3)5)</sup>	IM B35	With standard flange IM B14, <sup>1)</sup> IM V19 <sup>1)</sup>	IM B34	With special flange IM B14, IM V19 <sup>1)</sup>
	1	6	0	1	4	6	2	7	3
1LG6 18 - . . . . □□	○	○	□	✓	✓	✓	-	-	-
1LG6 20 - . . . . □□	○	○	□	✓	✓	✓	-	-	-
1LG6 22 - . . . . □□	○	○	□	✓	✓	✓	-	-	-
1LG6 25 - . . . . □□	○	○	□	✓	✓	✓	-	-	-
1LG6 28 - . . . . □□	○	○	□	✓	✓	✓	-	-	-
1LG6 310 - . . . □□	○	○	□	✓	✓	✓	-	-	-
1LG6 313 - . . . □□	○	○	□	✓	✓	✓	-	-	-
1LG6 316 - . . . □□	-	○	□ <sup>6)</sup>	-	✓	✓	-	-	-
1LG6 317 - . . . □□	-	○	□ <sup>6)</sup>	-	✓	✓	-	-	-
1LG6 318 - . . . □□	-	○	□ <sup>6)</sup>	-	✓	✓	-	-	-

- Standard version
- Without additional charge
- ✓ With additional charge
- Not possible

Order other voltages with voltage code **9** in the penultimate position and the corresponding order code (see "Special versions" in the "Selection and ordering data" under "Voltages").

Order other types of construction with type of construction code **9** in the final position and the corresponding order code (see "Special versions" in the "Selection and ordering data" under "Types of construction").

- <sup>1)</sup> The following applies for explosion-proof motors: In the case of the types of construction with shaft extension down, the version "with protective cover" is required. For types of construction with shaft extension pointing upwards, a suitable cover must be implemented to prevent small parts from falling into the fan cover (see the standard IEC/EN 60079-0). The cover must not block the cooling air-flow.
- <sup>2)</sup> If motors 1LG6 183-... to 1LG6 318-... (motor series 1LG6 frame sizes 180 M to 315 L) in types of construction with feet IM B6, IM B7 or IM V6 are fixed to the wall, it is recommended that the motor feet are supported.

- <sup>3)</sup> 1LG6 220-... to 1LG6 318-... motors (motor series 1LG6 frame sizes 225 S to 315 L) are supplied with two screw-in eyebolts in accordance with IM B5, whereby one can be relocated in accordance with IM V1 or IM V3. It is important to note that stress must not be applied perpendicular to the ring plane.
- <sup>4)</sup> Type of construction IM V3 is only possible using type of construction code **9** and order code **M1G**.
- <sup>5)</sup> The "Second shaft extension" option, order code **K16** is not possible.
- <sup>6)</sup> Type of construction IM V6 is only possible using type of construction code **9** and order code **M1E**.

# IEC Squirrel-Cage Motors

## Explosion-proof motors

Self-ventilated, in Zones 2, 21, 22 with type of prot. "n" or prot. against dust explosions – Cast-iron series 1LG6

### Selection and ordering data (continued)

Rated output at 60 Hz $P_{\text{rated}}$ HP	Frame size FS	Operating values at rated output				Nominal efficiency at 60 Hz $\eta_{\text{rated}}$ %	Power factor at 60 Hz 4/4-load $\cos\phi_{\text{rated}}$	Rated current at 460 V, 60 Hz $I_{\text{rated}}$ A	Order No. For Order No. supplements for voltage, type of construction and explosion protection zones according to ATEX, see tables below	Price	Weight IM B3 type of construction approx. $m$ kg
		Rated speed at 60 Hz $n_{\text{rated}}$ rpm	Rated torque at 60 Hz $T_{\text{rated}}$ Nm	EPACT with CC No. CC 032A							
<b>6-pole, 1200 rpm at 60 Hz, temperature class 155 (F), IP55 degree of protection, for use in the North American market according to EPACT</b>											
20	180 L	1178	121	Yes	91	0.8	25.5	<b>1LG6 186-6AA□□</b>		175	
25	200 L	1180	151	Yes	91.7	0.79	32.5	<b>1LG6 206-6AA□□</b>		210	
30	200 L	1180	181	Yes	91.7	0.8	38.5	<b>1LG6 207-6AA□□</b>		240	
40	225 M	1184	241	Yes	93	0.82	49	<b>1LG6 223-6AA□□</b>		325	
50	225 M	1184	301	Yes	93	0.83	61	<b>1LG6 228-6AA□□<sup>1)</sup></b>		355	
50	250 M	1186	300	No	93	0.82	61	<b>1LG6 253-6AA□□</b>		405	
60	250 M	1186	361	Yes	93.6	0.82	73	<b>1LG6 258-6AA□□<sup>1)</sup></b>		435	
60	280 S	1190	359	No	94.1	0.83	72	<b>1LG6 280-6AA□□</b>		520	
75	280 M	1190	449	No	94.5	0.83	89	<b>1LG6 283-6AA□□</b>		570	
100	280 M	1190	599	Yes	94.5	0.84	118	<b>1LG6 288-6AA□□<sup>1)</sup></b>		615	
100	315 S	1191	598	Yes	94.5	0.82	120	<b>1LG6 310-6AA□□</b>		760	
125	315 M	1191	747	Yes	94.5	0.84	148	<b>1LG6 313-6AA□□</b>		935	
150	315 L	1192	896	Yes	95	0.84	176	<b>1LG6 316-6AA□□</b>		1010	
175	315 L	1192	1046	Yes	95	0.84	205	<b>1LG6 317-6AA□□</b>		1180	
200	315 L	1192	1195	Yes	95.4	0.84	235	<b>1LG6 318-6AA□□</b>		1245	

### Special versions according to ATEX

Motor type	Frame size	Zone 2		VIK (includes Zone 2) <sup>2)</sup>		Zone 21		Zone 22	
		Mains-fed operation Order code M72	Converter-fed operation (FC) Order code M73	Mains-fed operation Order code K30	Converter-fed operation (FC) On request	Mains-fed operation Order code M34	Converter-fed operation (FC) Order code M38	Mains-fed operation Order code M35	Converter-fed operation (FC) Order code M39
<b>1LG6</b>	180	✓	✓	✓	✓	✓	✓	✓	✓
	200	✓	✓	✓	✓	✓	✓	✓	✓
	225	✓	✓	✓	✓	✓	✓	✓	✓
	250	✓	✓	✓	✓	✓	✓	✓	✓
	280	✓	✓	✓	✓	✓	✓	✓	✓
	315	✓	✓	✓	✓	✓	✓	✓	✓

✓ With additional charge

The motors can also be ordered in design for Zones 2 and 22 for non-conducting dust (IP55):  
Mains-fed operation – order code **M74**  
Converter-fed operation with derating – order code **M75**  
See "Special versions" in the "Selection and ordering data" under "Options".

**The motors can also be used for 50 Hz "High Efficiency", see Pages 4/70 to 4/73.**

<sup>1)</sup> Only 60 Hz data according to EPACT on the rating plate.

<sup>2)</sup> If the marking Ex nA II is required in addition to VIK on the rating plate, this must be ordered using order code **C27**. The VIK version is not possible in combination with Zone 21 and 22.

# IEC Squirrel-Cage Motors

## Explosion-proof motors

Self-ventilated, in Zones 2, 21, 22 with type of prot. "n" or prot. against dust explosions – Cast-iron series 1LG6

### Selection and ordering data (continued)

Order No.	Locked-rotor torque with direct starting torque	Locked-rotor current as multiple of rated current	Breakdown torque torque	Torque class	Moment of inertia	Noise at rated output	
	$T_{LR}/T_{rated}$	$I_{LR}/I_{rated}$	$T_B/T_{rated}$	CL	$J$ kgm <sup>2</sup>	Measuring surface sound pressure level at 60 Hz $L_{pFA}$ dB(A)	Sound pressure level at 60 Hz $L_{WA}$ dB(A)
<b>6-pole, 1200 rpm at 60 Hz, temperature class 155 (F), IP55 degree of protection, for use in the North American market according to EPACT</b>							
<b>1LG6 186-6AA□□</b>	2.9	6.5	3	16	0.2	57	70
<b>1LG6 206-6AA□□</b>	2.9	6.5	2.7	16	0.29	65	78
<b>1LG6 207-6AA□□</b>	2.9	6.4	2.7	16	0.36	65	78
<b>1LG6 223-6AA□□</b>	3.4	7.2	3.4	16	0.63	62	75
<b>1LG6 228-6AA□□</b>	3.2	7.6	3.4	16	0.76	61	74
<b>1LG6 253-6AA□□</b>	3.4	7.4	2.9	16	0.93	63	76
<b>1LG6 258-6AA□□</b>	3.4	7.4	2.9	16	1.07	65	79
<b>1LG6 280-6AA□□</b>	3.6	7.7	3.1	16	1.4	62	75
<b>1LG6 283-6AA□□</b>	3.9	8.3	3.3	16	1.6	62	75
<b>1LG6 288-6AA□□</b>	4	8.4	3.3	16	1.94	64	78
<b>1LG6 310-6AA□□</b>	3.3	8.4	3.4	16	2.5	66	79
<b>1LG6 313-6AA□□</b>	3	7.9	3.1	16	3.2	66	79
<b>1LG6 316-6AA□□</b>	3.3	8.5	3.3	16	4	66	79
<b>1LG6 317-6AA□□</b>	3.6	8.9	3.6	16	4.7	66	79
<b>1LG6 318-6AA□□</b>	4	9.4	4	16	5.4	69	82

### Order No. supplements

Motor type	Penultimate position: Voltage code		Final position: Type of construction code				With standard flange		With special flange
	60 Hz 460 VY 460 VΔ (see "Introduction" for outputs at 60 Hz)		Without flange IM B3/6/7/8, IM V6 <sup>1)2)</sup>	With flange IM B5, IM V3 1) 3) 4)	IM V1 with protective cover 1) 3) 5)	IM B35	IM B14, <sup>1)</sup> IM V19 <sup>1)</sup>	IM B34	IM B14, IM V19 <sup>1)</sup>
	<b>1</b>	<b>6</b>	<b>0</b>	<b>1</b>	<b>4</b>	<b>6</b>	<b>2</b>	<b>7</b>	<b>3</b>
<b>1LG6 18 - . . . □□</b>	○	○	□	✓	✓	✓	-	-	-
<b>1LG6 20 - . . . □□</b>	○	○	□	✓	✓	✓	-	-	-
<b>1LG6 22 - . . . □□</b>	○	○	□	✓	✓	✓	-	-	-
<b>1LG6 25 - . . . □□</b>	○	○	□	✓	✓	✓	-	-	-
<b>1LG6 28 - . . . □□</b>	○	○	□	✓	✓	✓	-	-	-
<b>1LG6 310 - . . . □□</b>	○	○	□	✓	✓	✓	-	-	-
<b>1LG6 313 - . . . □□</b>	○	○	□	✓	✓	✓	-	-	-
<b>1LG6 316 - . . . □□</b>	-	○	□ <sup>6)</sup>	-	✓	✓	-	-	-
<b>1LG6 317 - . . . □□</b>	-	○	□ <sup>6)</sup>	-	✓	✓	-	-	-
<b>1LG6 318 - . . . □□</b>	-	○	□ <sup>6)</sup>	-	✓	✓	-	-	-

- Standard version
- Without additional charge
- ✓ With additional charge
- Not possible

Order other voltages with voltage code **9** in the penultimate position and the corresponding order code (see "Special versions" in the "Selection and ordering data" under "Voltages").

Order other types of construction with type of construction code **9** in the final position and the corresponding order code (see "Special versions" in the "Selection and ordering data" under "Types of construction").

- <sup>1)</sup> The following applies for explosion-proof motors: In the case of the types of construction with shaft extension down, the version "with protective cover" is required. For types of construction with shaft extension pointing upwards, a suitable cover must be implemented to prevent small parts from falling into the fan cover (see the standard IEC/EN 60079-0). The cover must not block the cooling air-flow.
- <sup>2)</sup> If motors 1LG6 183-... to 1LG6 318-... (motor series 1LG6 frame sizes 180 M to 315 L) in types of construction with feet IM B6, IM B7 or IM V6 are fixed to the wall, it is recommended that the motor feet are supported.

- <sup>3)</sup> 1LG6 220-... to 1LG6 318-... motors (motor series 1LG6 frame sizes 225 S to 315 L) are supplied with two screw-in eyebolts in accordance with IM B5, whereby one can be relocated in accordance with IM V1 or IM V3. It is important to note that stress must not be applied perpendicular to the ring plane.
- <sup>4)</sup> Type of construction IM V3 is only possible using type of construction code **9** and order code **M1G**.
- <sup>5)</sup> The "Second shaft extension" option, order code **K16** is not possible.
- <sup>6)</sup> Type of construction IM V6 is only possible using type of construction code **9** and order code **M1E**.

# IEC Squirrel-Cage Motors

## Explosion-proof motors

Self-ventilated, in Zones 2 and 22 with type of prot. "n" or prot. against dust explosions – Cast-iron series 1LA8

### Selection and ordering data

The data for series 1LA8 with type of protection "n" or protection against dust explosions can be found in the selection and ordering data in catalog part 3 "Non-standard motors of frame size 315 and above". The technical specifications are identical to the specifications of the non-explosion-proof versions. They are or-

dered using additional order options (special versions). These special versions for voltages, construction types or options are listed in catalog part 3 "Non-standard motors frame size 315 and above".

### Special versions according to ATEX

Motor type	Zone 2		VIK <sup>1)</sup> (includes Zone 2, utilization 155 (F) according to 130 (B))		Zone 21		Zone 22		
	Frame size	Mains-fed operation Order code <b>M72</b>	Converter-fed operation (FC) Order code <b>M73</b>	Mains-fed operation Order code <b>K30</b>	Converter-fed operation (FC) On request	Mains-fed operation Order code <b>M34</b>	Converter-fed operation (FC) Order code <b>M38</b>	Mains-fed operation Order code <b>M35</b>	Converter-fed operation (FC) Order code <b>M39</b>
<b>1LA8</b>	315	✓	O. R.	✓	O. R.	–	–	✓	✓
	355	✓	O. R.	✓	O. R.	–	–	✓	✓
	400	✓	O. R.	–	–	–	–	✓	✓
	450	✓	O. R.	–	–	–	–	✓	✓

O. R. Possible on request

✓ With additional charge

– Not possible

4

Forced-air cooled, in Zones 2 and 22 with type of prot. "n" or prot. against dust explosions – Cast-iron series 1PQ8

### Selection and ordering data

The data for series 1PQ8 with type of protection "n" or protection against dust explosions can be found in the selection and ordering data in catalog part 3 "Non-standard motors of frame size 315 and above". The technical specifications are identical to the specifications of the non-explosion-proof versions. They are or-

dered using additional order options (special versions). These special versions for voltages, construction types or options are listed in catalog part 3 "Non-standard motors frame size 315 and above". Motor series 1PQ8 for converter-fed operation in Zone 2 available on request.

<sup>1)</sup> If the marking Ex nA II is required in addition to VIK on the rating plate, this must be ordered using order code **C27**. The VIK version is not possible in combination with Zone 21 and 22.

### Overview

#### General information

Ex motors in vertical type of construction with shaft extension pointing down must have a protective cover.

Extensive operating instructions are supplied as standard with explosion-proof motors.

For all explosion-proof motors, designs according to UL (order code **D31**) and CSA (order code **D40**) are not possible.

#### Motor connection

For motors in Ex version (except for Zone 22, VIK, certified metric cable glands/sealing plugs are included in the scope of supply.

#### Mains-fed operation

Motors to type of protection

- Ex e are only certified for mains-fed operation. 2-pole motors 1MA frame sizes 132 to 160 are designed with double rating plate (T1/T2 and T3) as standard. For motor versions with order codes A11/A12 or with voltage code "9" T3-output is then stamped on the rating plate as standard. Alternatively, "T1/T2-output on the rating plate" can be stamped – order code **C30**
- Ex de/Ex d are designed in the basic version for mains-fed operation
- Motors 1MJ6/1MJ7 for use in type of protection Ex d/de (Zone 1)/dust-Ex Zone 21, as well as Zone 22 for conducting dust – order code **M76**
- Motors 1LA/1LG can be modified for use in Zones 2, 21 or 22 if they are ordered using order codes:
  - Design for Zone 2 for mains-fed operation – (order code **M72**)
  - Design for Zones 2 and 22 for non-conducting dust (IP55) for mains-fed operation – (order code **M74**)
  - Design for Zone 21<sup>1)</sup>, as well as Zone 22 for conducting dust (IP65) for mains-fed operation – (order code **M34**)
  - Design for Zone 22 for non-conducting dust (IP55) for mains-fed operation – (order code **M35**)

Certified motor protection switches/tripping units must be used for motor protection, see Catalog LV 1.

<sup>1)</sup> Zone 21 takes into account conducting and non-conducting dust.

# IEC Squirrel-Cage Motors

## Explosion-proof motors

### Special versions

#### Converter-fed operation

The motors are suitable for use with converters for voltage rise times  $t_{\text{r}} > 0.1 \mu\text{s}$  for  $U \leq 460 \text{ V}$  (for motor series 1LA8 up to 500 V).

For converter-fed operation, Ex motors must always be monitored using PTC thermistors. Certified tripping units are required for this purpose, see Catalog LV 1.

For converter-fed operation with frame size 225 and above, it is recommended that an "Insulated bearing cartridge" – order code **L27** is used.

Type of protection "Explosion-proof enclosure" Ex de IIC T4/Ex d IIC T4

The motors must be ordered with:

- Motor protection with PTC thermistors for converter-fed operation with 4 embedded temperature sensors for tripping – Order code **A15**

or

- Motor protection with PTC thermistors for converter-fed operation with 8 embedded temperature sensors for alarm and tripping – Order code **A16**

or

- Design for Zones 1 and 21, as well as Zone 22 for conducting dust (IP65) for converter-fed operation, derating – order code **M77** (incl. order code **A15**)

For motor series 1MJ6 and 1MJ7, a fourth PTC thermistor is installed in the connection box.

Thermal utilization is according to temperature class 155 (F).

The EU type test certificate and factory certificate 2.1 also cover converter-fed operation.

General converters for Zone 2/21/22

1LA and 1LG motors for Zones 2, 21 and 22 for converter-fed operation have 3 PTC thermistors for tripping as standard. 1LG4/1LG6 motors also have an additional PTC thermistor in the connection box.

Optionally available: PTC thermistors for alarm for converter-fed operation in Zones 2, 21, 22 – Order code **A10**

For all motors, "MICROMASTER DUTY S9" is stamped on the rating plate complete with the relevant rating data. (Exception: Motor series 1LA8 and 1PQ8).

These rated operating points apply for both constant torque drives and pump/fan/compressor drives. For a constant torque drive, the resulting thermal motor torques in the positioning range must be taken into account.

On the rating plate, four rated operating points are possible in the following variants:

Possible variants:	Rated operating points in Hz				Additional order information
50 Hz field weakening range	5	25	50	$f_{\text{max}}$	<b>50 Hz voltage: e.g. "9" and L1A</b>
60 Hz field weakening range	6	30	60	$f_{\text{max}}$	<b>60 Hz voltage: e.g. "9" and L2E</b>
87 Hz characteristic	5	25	87	$f_{\text{max}}$	<b>87 Hz at 400 VΔ: "9" and L3A</b>

Alternatively, rated operating points for SIMOVERT MASTERDRIVES, SINAMICS G110, SINAMICS S120 or ET 200S FC on the rating plate can be ordered as follows:

**Y68 with plain text (C text): Y68:SIMOVERT MASTERDRIVES**

**Y68 with plain text (C text): Y68:SINAMICS G110**

**Y68 with plain text (C text): Y68:ET 200S FC**

**Y68 with plain text (C text): Y68:SINAMICS S120**

- The converter type and the associated rating data are on the rating plate

*The reasons for this are the different control levels for the converter with a converter output frequency of 45 Hz and above and the associated derating of the motor.*

*For compliance with temperature class 130 (B), derating is necessary in the case of converter-fed operation in Zones 2, 21 and 22. Derating information is available in the configuration tool SIZER (see Appendix).*

The certificates for the motors and converters for hazardous areas are stored under "Documentation" in the SD configurator tool for low-voltage motors.

**Only "one" voltage must be assigned to voltage codes/ order codes:**

Voltage code	Order code	Mains voltage
<b>3</b>	-	500 VY 50 Hz
<b>5</b>	-	500 VΔ 50 Hz
<b>9</b>	<b>L1A</b>	400 VY 50 Hz
<b>9</b>	<b>L1B</b>	400 VΔ 50 Hz
<b>9</b>	<b>L1C</b>	415 VY 50 Hz
<b>9</b>	<b>L1D</b>	415 VΔ 50 Hz
<b>9</b>	<b>L2E</b>	460 VY 60 Hz
<b>9</b>	<b>L2F</b>	460 VΔ 60 Hz
<b>9</b>	<b>L2W</b>	440 VY 60 Hz
<b>9</b>	<b>L2X</b>	440 VΔ 60 Hz
<b>9</b>	<b>L1Y</b> (non-standard winding)	Plain text (max. 460 VY 50 or 60 Hz)
<b>9</b>	<b>L3A</b> <sup>1)</sup>	For 87 Hz 400 VΔ (4 to 8-pole)

<sup>1)</sup> Not technically possible for 1LG, FS 315 L.

### Overview (continued)

#### 1LA8, 1PQ8 motors for converter-fed operation

When 1LA8 and 1PQ8 motors are ordered, the speed setting range and the load torque must be specified as well as whether the application is for a “Constant torque drive” or a “Fan/pump/compressor drive”.

In some cases, a system test must be performed to ensure that the admissible limit temperature is not exceeded.

- A system test is not generally required for motors for applications with quadratic load torque ( $M \sim n^2$ ).
- A system test is usually required for motors for applications with constant load torque. In individual cases in which the motor type has already been measured once using the same speed setting range, a new system test is not necessary.

Please inquire in such cases.

For all motors, an additional rating plate complete with the rating data for the converter is fitted.

#### Converters specially for Zone 2, type of protection “n” or Ex nA II T3

The motors must be ordered with

- **Design for Zone 2 for converter-fed operation, derating**  
Ex nA II T3 acc. to IEC/EN 60079-15 – Order code **M73**.

In the version for order code **M73**, PTC thermistors are included in accordance with temperature class 130 (B).

The IEC/EN 60079-15 standard requires that the converter drive for motors is subjected to the “non-sparking” test. The test is available for Siemens motors Ex nA II on Siemens converters in accordance with Factory Certificate 2.1.

Please inquire in the case of a non-Siemens converter (additional charge).

The test will cost more in the case of non-Siemens converters (especially on commissioning).

Commissioning personnel must be provided by the customer for setting up and operating the non-Siemens converter during the test, if required.

#### Converters specially for Zone 21/22

The motors must be ordered with:

- Design for Zone 21<sup>1)</sup>, as well as Zone 22 for conducting dust (IP65) for converter-fed operation, derating – Order code **M38**
- Design for Zone 22 for non-conducting dust (IP55) for converter-fed operation, derating – Order code **M39**

In order codes **M38/M39**, PTC thermistors are included in accordance with temperature class 130 (B).

Please inquire in the case of a non-Siemens converter (additional charge).

#### Converters for Zone 2/22

The motors must be ordered with:

- Design for Zones 2 and 22 for non-conducting dust (IP55) for converter-fed operation, derating – Order code **M75**

In order code **M75**, PTC thermistors are included in accordance with temperature class 130 (B).

Please inquire in the case of a non-Siemens converter (additional charge).

#### VIK version

VIK standard version:

- VIK version – Order code **K30**

VIK version “Non-sparking”:

- “Ex nA II T3” marking on VIK rating plate according to Directive 94/9/EU (ATEX) – Order code **C27**

The motors in VIK design (**K30**) contain technology for Zone 2 in Ex nA II T3 type of protection. In accordance with VIK recommendations, “Ex nA II T3” will only be stamped on the rating plate on the express wish of the customer when ordering with order code **C27**.

Note: When ordering, **C27** must be specified in addition to **K30**.

Motors up to frame size 355 can be supplied in accordance with the technical requirements of the VIK (Verband der Industriellen Energie- und Kraftwirtschaft e.V.). Not possible for 1LA5 motors, 1LG4 motors will be supplied.

1LG4, 1LG6, 1MJ6 and 1MJ7 motors in frame size 315 are supplied with special connection boxes with a removable cable entry plate.

Note the output and dimensions in the case of 1LA8 motors. With 1LA8 motors the connection boxes cannot be rotated by  $4 \times 90^\circ$ . Motors in a vertical type of construction with the shaft extension pointing down must have a protective cover (e.g. type of construction code **4**). Use according to temperature class 130 (B) is mandatory. Frame sizes 400 and 450 are not included in VIK.

Please inquire about converter-fed operation in all cases.

Motors in VIK design with mounted technology (brake, rotary pulse encoder, separately driven fan and anti-condensation heater) are not compatible with Zone 2. Designs for Zone 21/22 are not possible.

#### Chinese explosion-proof certification

For projects in China in particular, explosion-proof motors are required that have been approved by a named Chinese testing authority.

Ex certification for China – Order code **D32**

The following motor series have Chinese Ex certification:

- Zone 1 type of protection “d” or Ex de IIC T4/Ex d IIC T4: 1MJ6, 1MJ7
- Zone 2 type of protection “n” or Ex nA II T3: 1LA6, 1LA7, 1LA9, 1LG when ordered in:
  - **Design for Zone 2 for mains-fed operation**  
Ex nA II T3 acc. to IEC/EN 60079-15 – Order code **M72**.
  - **Design for Zone 2 for converter-fed operation, derating**  
Ex nA II T3 acc. to IEC/EN 60079-15 – Order code **M73**.

In addition, the VIK design for motor series 1MJ6, 1MJ7, 1LA, 1LG can also be ordered with Ex certification for China.

When these motors are ordered in the version

- “Ex certification for China” – Order code **D32**

the “NEPSI<sup>2)</sup> certificate number” and the “NEPSI” logo are stamped on the rating plate.

For motor series 1LA8, the “CQST<sup>3)</sup> certificate number” and the logo: “CQST” are then stamped on the rating plate.

<sup>1)</sup> Zone 21 takes into account conducting and non-conducting dust.

<sup>2)</sup> NEPSI = National Supervision and Inspection Center for Explosion Protection and Safety of Instrumentation.

<sup>3)</sup> CQST = China National Quality Supervision and Test Centre for Explosion Protected Electrical Products.

# IEC Squirrel-Cage Motors

## Explosion-proof motors

### Special versions

#### Selection and ordering data

##### Voltages

Additional order codes for other voltages or voltage codes (without **-Z** supplement)

For some non-standard voltages at 50 or 60 Hz, order codes are specified. They are ordered by specifying the code digit **9** for voltage in the 11th position of the Order No. and the appropriate order code.

Special versions	Voltage code	Additional identification code with order code and plain text if required	Motor type frame size														
			56	63	71	80	90	100	112	132	160	180	200	225	250	280	315 S/M
<b>Self-ventilated motors in Zone 1 with type of protection "e" – Aluminum series 1MA7</b>																	
<b>1MA7 (aluminum)</b>																	
<b>Voltage at 50 Hz</b>																	
220 VΔ/380 VY (209 ... 231 VΔ/361 ... 399 VY); 50 Hz output <sup>1)</sup>	9	L1R	✓	✓	✓	✓	✓	✓	✓	✓	✓	✓	✓	✓	✓	✓	✓
230 VΔ (218 ... 242 VΔ); 50 Hz output <sup>1)</sup>	9	L1E	○	○	○	○	○	○	○	○	○	○	○	○	○	○	○
380 VΔ/660 VY (361 ... 399 VΔ/627 ... 693 VY); 50 Hz output <sup>1)</sup>	9	L1L	–	✓	✓	✓	✓	✓	✓	✓	✓	✓	✓	✓	✓	✓	✓
415 VY (394 ... 436 VY); 50 Hz output <sup>1)</sup>	9	L1C	✓ <sup>2)</sup>	✓	✓	✓	✓	✓	✓	✓	✓	✓	✓	✓	✓	✓	✓
415 VΔ (394 ... 436 VΔ); 50 Hz output <sup>1)</sup>	9	L1D	–	✓	✓	✓	✓	✓	✓	✓	✓	✓	✓	✓	✓	✓	✓
<b>Voltage at 60 Hz <sup>3)</sup></b>																	
220 VΔ/380 VY; 50 Hz output	9	L2A	✓	✓	✓	✓	✓	✓	✓	✓	✓	✓	✓	✓	✓	✓	✓
380 VΔ/660 VY; 50 Hz output	9	L2C	✓ <sup>4)</sup>	✓	✓	✓	✓	✓	✓	✓	✓	✓	✓	✓	✓	✓	✓
440 VY; 50 Hz output	9	L2Q	✓	✓	✓	✓	✓	✓	✓	✓	✓	✓	✓	✓	✓	✓	✓
440 VΔ; 50 Hz output	9	L2R	–	✓	✓	✓	✓	✓	✓	✓	✓	✓	✓	✓	✓	✓	✓
460 VY; 50 Hz output	9	L2S	✓ <sup>2)</sup>	✓	✓	✓	✓	✓	✓	✓	✓	✓	✓	✓	✓	✓	✓
460 VΔ; 50 Hz output	9	L2T	–	✓	✓	✓	✓	✓	✓	✓	✓	✓	✓	✓	✓	✓	✓
575 VY; 50 Hz output	9	L2U	✓ <sup>4)</sup>	✓	✓	✓	✓	✓	✓	✓	✓	✓	✓	✓	✓	✓	✓
575 VΔ; 50 Hz output	9	L2V	–	✓	✓	✓	✓	✓	✓	✓	✓	✓	✓	✓	✓	✓	✓
<b>Non-standard voltage and/or frequencies</b>																	
Non-standard winding for voltages between 200 and 690 V (voltages outside this range are available on request) <sup>5)</sup>	9	L1Y •	✓	✓	✓	✓	✓	✓	✓	✓	✓	✓	✓	✓	✓	✓	✓
<b>Self-ventilated motors in Zone 1 with type of protection "e" – Cast-iron series 1MA6</b>																	
<b>1MA6 (cast-iron)</b>																	
<b>Voltage at 50 Hz</b>																	
220 VΔ/380 VY (209 ... 231 VΔ/361 ... 399 VY); 50 Hz output <sup>1)</sup>	9	L1R	✓	✓	✓	✓	✓	✓	✓	✓	✓	✓	✓	✓	✓	✓	✓
230 VΔ (218 ... 242 VΔ); 50 Hz output <sup>1)</sup>	9	L1E	○	○	○	○	○	○	○	○	○	○	○	○	○	○	○
380 VΔ/660 VY (361 ... 399 VΔ/627 ... 693 VY); 50 Hz output <sup>1)</sup>	9	L1L	✓	✓	✓	✓	✓	✓	✓	✓	✓	✓	✓	✓	✓	✓	✓
415 VY (394 ... 436 VY); 50 Hz output <sup>1)</sup>	9	L1C	✓	✓	✓	✓	✓	✓	✓	✓	✓	✓	✓	✓	✓	✓	✓
415 VΔ (394 ... 436 VΔ); 50 Hz output <sup>1)</sup>	9	L1D	✓	✓	✓	✓	✓	✓	✓	✓	✓	✓	✓	✓	✓	✓	✓
<b>Voltage at 60 Hz <sup>3)</sup></b>																	
220 VΔ/380 VY; 50 Hz output	9	L2A	✓	✓	✓	✓	✓	✓	✓	✓	✓	✓	✓	✓	✓	✓	✓
380 VΔ/660 VY; 50 Hz output	9	L2C	✓	✓	✓	✓	✓	✓	✓	✓	✓	✓	✓	✓	✓	✓	✓
440 VY; 50 Hz output	9	L2Q	✓	✓	✓	✓	✓	✓	✓	✓	✓	✓	✓	✓	✓	✓	✓
440 VΔ; 50 Hz output	9	L2R	✓	✓	✓	✓	✓	✓	✓	✓	✓	✓	✓	✓	✓	✓	✓
460 VY; 50 Hz output	9	L2S	✓	✓	✓	✓	✓	✓	✓	○	○	○	○	○	○	○	○
460 VΔ; 50 Hz output	9	L2T	✓	✓	✓	✓	✓	✓	✓	○	○	○	○	○	○	○	○
575 VY; 50 Hz output	9	L2U	✓	✓	✓	✓	✓	✓	✓	○	○	○	○	○	○	○	○
575 VΔ; 50 Hz output	9	L2V	✓	✓	✓	✓	✓	✓	✓	○	○	○	○	○	○	○	○
<b>Non-standard voltage and/or frequencies</b>																	
Non-standard winding for voltages between 200 and 690 V (voltages outside this range are available on request) <sup>5)</sup>	9	L1Y •	✓	✓	✓	✓	✓	✓	✓	✓	✓	✓	✓	✓	✓	✓	✓

- Without additional charge
- ✓ With additional charge
- Not possible

- This order code only determines the price of the version – Additional plain text is required.

Footnotes, see Page 4/85.



# IEC Squirrel-Cage Motors

## Explosion-proof motors

### Special versions

Special versions	Voltage code 11th position of the Order No.	Additional identification code with order code and plain text if required	Motor type frame size														
			56	63	71	80	90	100	112	132	160	180	200	225	250	280	315 S/M
<b>Self-ventilated motors in Zone 1 with type of protection "de" – Cast-iron series 1MJ6 and 1MJ7</b>																	
			<b>1MJ6 (cast-iron)</b>									<b>1MJ7 (cast-iron)</b>					
<b>Voltage at 50 Hz</b>																	
220 VΔ/380 VY (210 ... 230 VΔ/360 ... 400 VY); 50 Hz output <sup>1)</sup>	9	L1R	✓	✓	✓	✓	✓	✓	✓	✓	✓	✓	✓	✓	✓	✓	–
230 VΔ (220 ... 240 VΔ); 50 Hz output <sup>1)</sup>	9	L1E	○	○	○	○	○	○	○	○	○	○	○	○	○	○	–
380 VΔ/660 VY (360 ... 400 VΔ/625 ... 695 VY); 50 Hz output <sup>1)</sup>	9	L1L	✓	✓	✓	✓	✓	✓	✓	✓	✓	✓	✓	✓	✓	✓	–
415 VY (395 ... 435 VY); 50 Hz output <sup>1)</sup>	9	L1C	✓	✓	✓	✓	✓	✓	✓	✓	✓	✓	✓	✓	✓	✓	–
415 VΔ (395 ... 435 VΔ); 50 Hz output <sup>1)</sup>	9	L1D	✓	✓	✓	✓	✓	✓	✓	✓	✓	✓	✓	✓	✓	✓	–
<b>Voltage at 60 Hz</b>																	
220 VΔ/380 VY; 50 Hz output	9	L2A	✓	✓	✓	✓	✓	✓	✓	✓	✓	✓	✓	✓	✓	✓	–
220 VΔ/380 VY; 60 Hz output	9	L2B	✓	✓	✓	✓	✓	✓	✓	✓	✓	✓	✓	✓	✓	✓	–
380 VΔ/660 VY; 50 Hz output	9	L2C	✓	✓	✓	✓	✓	✓	✓	✓	✓	✓	✓	✓	✓	✓	–
380 VΔ/660 VY; 60 Hz output	9	L2D	✓	✓	✓	✓	✓	✓	✓	✓	✓	✓	✓	✓	✓	✓	–
440 VY; 50 Hz output	9	L2Q	✓	✓	✓	✓	✓	✓	✓	✓	✓	✓	✓	✓	✓	✓	–
440 VY; 60 Hz output	9	L2W	✓	✓	✓	✓	✓	✓	✓	✓	✓	✓	✓	✓	✓	✓	–
440 VΔ; 50 Hz output	9	L2R	✓	✓	✓	✓	✓	✓	✓	✓	✓	✓	✓	✓	✓	✓	–
440 VΔ; 60 Hz output	9	L2X	✓	✓	✓	✓	✓	✓	✓	✓	✓	✓	✓	✓	✓	✓	–
460 VY; 50 Hz output	9	L2S	✓	✓	✓	✓	✓	✓	✓	✓	✓	✓	✓	✓	✓	✓	–
460 VY; 60 Hz output	9	L2E	✓	✓	✓	✓	✓	✓	✓	✓	✓	✓	✓	○	○	○	○
460 VΔ; 50 Hz output	9	L2T	✓	✓	✓	✓	✓	✓	✓	✓	✓	✓	✓	✓	✓	✓	–
460 VΔ; 60 Hz output	9	L2F	✓	✓	✓	✓	✓	✓	✓	✓	✓	✓	✓	○	○	○	○
575 VY; 50 Hz output	9	L2U	✓	✓	✓	✓	✓	✓	✓	✓	✓	✓	✓	✓	✓	✓	–
575 VY; 60 Hz output	9	L2L	✓	✓	✓	✓	✓	✓	✓	✓	✓	✓	✓	✓	✓	✓	–
575 VΔ; 50 Hz output	9	L2V	✓	✓	✓	✓	✓	✓	✓	✓	✓	✓	✓	✓	✓	✓	–
575 VΔ; 60 Hz output	9	L2M	✓	✓	✓	✓	✓	✓	✓	✓	✓	✓	✓	○	○	○	○
<b>Non-standard voltage and/or frequencies</b>																	
Non-standard winding for voltages between 200 and 690 V (voltages outside this range are available on request) <sup>3)</sup>	9	L1Y •	✓	✓	✓	✓	✓	✓	✓	✓	✓	✓	✓	✓	✓	✓	✓

- Without additional charge
- ✓ With additional charge
- Not possible
- This order code only determines the price of the version – Additional plain text is required.

<sup>1)</sup> For order codes **L1C**, **L1D**, **L1E**, **L1L**, **L1R**, **L1U** and **L1A** a rated voltage range is also marked on the rating plate.

<sup>2)</sup> For motors 1MA7 060-4 (motor series 1MA7 frame size 63, 4-pole) not possible.

<sup>3)</sup> Special certification is required for 60 Hz.

<sup>4)</sup> For motors 1MA7 060-2, 1MA7 060-4 and 1MA7 063-4 (motor series 1MA7 frame size 63, 2- and 4-pole) not possible.

<sup>5)</sup> Plain text must be specified in the order: Voltage, frequency, circuit, required rated output in kW.

# IEC Squirrel-Cage Motors

## Explosion-proof motors

### Special versions

Special versions	Voltage code	Additional identification code with order code and plain text if required	Motor type frame size														
			56	63	71	80	90	100	112	132	160	180	200	225	250	280	315
<b>Self-ventilated motors in Zones 2, 21 and 22 with type of protection “n” or protection against dust explosions – Aluminum series 1LA7 and 1LA5</b>																	
			<b>1LA7 (aluminum) <sup>1)</sup></b>										<b>1LA5 (aluminum) <sup>1)</sup></b>				
<b>Voltage at 50 Hz</b>																	
220 VΔ/380 VY (440 VY at 60 Hz) (210 ... 230 VΔ/360 ... 400 VY); 50 Hz output <sup>2)</sup>	9	L1R	✓	✓	✓	✓	✓	✓	✓	✓	✓	✓	✓	✓	✓	✓	
230 VΔ (220 ... 240 VΔ); 50 Hz output <sup>2)</sup>	9	L1E	○	○	○	○	○	○	○	○	○	○	○	○	○	○	
380 VΔ/660 VY (440 VΔ at 60 Hz) (360 ... 400 VΔ/625 ... 695 VY); 50 Hz output <sup>2)</sup>	9	L1L	✓	✓	✓	✓	✓	✓	✓	✓	✓	✓	✓	✓	✓	✓	
415 VY (395 ... 435 VY); 50 Hz output <sup>2)</sup>	9	L1C	✓	✓	✓	✓	✓	✓	✓	✓	✓	✓	✓	✓	✓	✓	
415 VΔ (395 ... 435 VΔ); 50 Hz output <sup>2)</sup>	9	L1D	✓	✓	✓	✓	✓	✓	✓	✓	✓	✓	✓	✓	✓	✓	
400 VY (380 ... 420 VY); 50 Hz output <sup>2)</sup>	9	L1A	○	○	○	○	○	○	○	○	○	○	○	○	○	○	
400 VΔ (380 ... 420 VΔ); 50 Hz output <sup>2)</sup>	9	L1B	○	○	○	○	○	○	○	○	○	○	○	○	○	○	
400 VΔ (460 VΔ bei 60 Hz) (380 ... 420 VΔ); 50 Hz output <sup>2)</sup>	9	L1U	○	○	○	○	○	○	○	○	○	○	○	○	○	○	
400 VΔ 87 Hz output (4-pole to 8-pole only) <sup>3)</sup>	9	L3A	○	○	○	○	○	○	○	○	○	○	○	○	○	○	
<b>Voltage at 60 Hz</b>																	
220 VΔ/380 VY; 50 Hz output	9	L2A	✓	✓	✓	✓	✓	✓	✓	✓	✓	✓	✓	✓	✓	✓	
220 VΔ/380 VY; 60 Hz output	9	L2B	✓	✓	✓	✓	✓	✓	✓	✓	✓	✓	✓	✓	✓	✓	
380 VΔ/660 VY; 50 Hz output	9	L2C	✓	✓	✓	✓	✓	✓	✓	✓	✓	✓	✓	✓	✓	✓	
380 VΔ/660 VY; 60 Hz output	9	L2D	✓	✓	✓	✓	✓	✓	✓	✓	✓	✓	✓	✓	✓	✓	
440 VY; 50 Hz output	9	L2Q	✓	✓	✓	✓	✓	✓	✓	✓	✓	✓	✓	✓	✓	✓	
440 VY; 60 Hz output	9	L2W	✓	✓	✓	✓	✓	✓	✓	✓	✓	✓	✓	✓	✓	✓	
440 VΔ; 50 Hz output	9	L2R	✓	✓	✓	✓	✓	✓	✓	✓	✓	✓	✓	✓	✓	✓	
440 VΔ; 60 Hz output	9	L2X	✓	✓	✓	✓	✓	✓	✓	✓	✓	✓	✓	✓	✓	✓	
460 VY; 50 Hz output	9	L2S	✓	✓	✓	✓	✓	✓	✓	✓	✓	✓	✓	✓	✓	✓	
460 VY; 60 Hz output	9	L2E	○	○	○	○	○	○	○	○	○	○	○	○	○	○	
460 VΔ; 50 Hz output	9	L2T	✓	✓	✓	✓	✓	✓	✓	✓	✓	✓	✓	✓	✓	✓	
460 VΔ; 60 Hz output	9	L2F	○	○	○	○	○	○	○	○	○	○	○	○	○	○	
575 VY; 50 Hz output	9	L2U	✓	✓	✓	✓	✓	✓	✓	✓	✓	✓	✓	✓	✓	✓	
575 VY; 60 Hz output	9	L2L	✓	✓	✓	✓	✓	✓	✓	✓	✓	✓	✓	✓	✓	✓	
575 VΔ; 50 Hz output	9	L2V	✓	✓	✓	✓	✓	✓	✓	✓	✓	✓	✓	✓	✓	✓	
575 VΔ; 60 Hz output	9	L2M	✓	✓	✓	✓	✓	✓	✓	✓	✓	✓	✓	✓	✓	✓	
<b>Non-standard voltage and/or frequencies</b>																	
Non-standard winding for voltages between 200 V and 690 V (voltages outside this range are available on request) <sup>4)</sup>	9	L1Y •	✓	✓	✓	✓	✓	✓	✓	✓	✓	✓	✓	✓	✓	✓	

- Without additional charge
- ✓ With additional charge
- This order code only determines the price of the version – Additional plain text is required.

<sup>1)</sup> Zone 2 is not possible for motor series 1LA5 and motor series 1LA7 for frame size 56.

<sup>2)</sup> For Zones 21 and 22, for order codes **L1C, L1D, L1E, L1L, L1R, L1U, L1B** and **L1A** a rated voltage range is also marked on the rating plate.

<sup>3)</sup> The rating data for converter-fed operation is also provided in a table on the rating plate.

<sup>4)</sup> Plain text must be specified in the order: Voltage, frequency, circuit, required rated output in kW.

# IEC Squirrel-Cage Motors

## Explosion-proof motors

### Special versions

Special versions	Voltage code 11th position of the Order No.	Additional identifica- tion code with order code and plain text if required	Motor type frame size													
			56	63	71	80	90	100	112	132	160	180	200	225	250	280
<b>Self-ventilated motors in Zones 2, 21 and 22 with type of protection "n" or protection against dust explosions – Aluminum series 1LA9</b>																
<b>1LA9 (aluminum)</b>																
<b>Voltage at 50 Hz</b>																
220 VΔ/380 VY (440 VY at 60 Hz) (210 ... 230 VΔ/360 ... 400 VY); 50 Hz output <sup>1)</sup>	9	L1R	✓	✓	✓	✓	✓	✓	✓	✓	✓	✓	✓	✓	✓	✓
230 VΔ (220 ... 240 VΔ); 50 Hz output <sup>1)</sup>	9	L1E	○	○	○	○	○	○	○	○	○	○	○	○	○	○
380 VΔ/660 VY (440 VΔ at 60 Hz) (360 ... 400 VΔ/625 ... 695 VY); 50 Hz output <sup>1)</sup>	9	L1L	✓	✓	✓	✓	✓	✓	✓	✓	✓	✓	✓	✓	✓	✓
415 VY (395 ... 435 VY); 50 Hz output <sup>1)</sup>	9	L1C	✓	✓	✓	✓	✓	✓	✓	✓	✓	✓	✓	✓	✓	✓
415 VΔ (395 ... 435 VΔ); 50 Hz output <sup>1)</sup>	9	L1D	✓	✓	✓	✓	✓	✓	✓	✓	✓	✓	✓	✓	✓	✓
400 VY (380 ... 420 VY); 50 Hz output <sup>1)</sup>	9	L1A	○	○	○	○	○	○	○	○	○	○	○	○	○	○
400 VΔ (380 ... 420 VΔ); 50 Hz output <sup>1)</sup>	9	L1B	○	○	○	○	○	○	○	○	○	○	○	○	○	○
400 VΔ (460 VΔ bei 60 Hz) (380 ... 420 VΔ); 50 Hz output <sup>1)</sup>	9	L1U	○	○	○	○	○	○	○	○	○	○	○	○	○	○
400 VΔ 87 Hz output (4-pole to 8-pole only) <sup>2)</sup>	9	L3A	○	○	○	○	○	○	○	○	○	○	○	○	○	○
<b>Voltage at 60 Hz</b>																
220 VΔ/380 VY; 50 Hz output	9	L2A	✓	✓	✓	✓	✓	✓	✓	✓	✓	✓	✓	✓	✓	✓
220 VΔ/380 VY; 60 Hz output	9	L2B	✓	✓	✓	✓	✓	✓	✓	✓	✓	✓	✓	✓	✓	✓
380 VΔ/660 VY; 50 Hz output	9	L2C	✓	✓	✓	✓	✓	✓	✓	✓	✓	✓	✓	✓	✓	✓
380 VΔ/660 VY; 60 Hz output	9	L2D	✓	✓	✓	✓	✓	✓	✓	✓	✓	✓	✓	✓	✓	✓
440 VY; 50 Hz output	9	L2Q	✓	✓	✓	✓	✓	✓	✓	✓	✓	✓	✓	✓	✓	✓
440 VY; 60 Hz output	9	L2W	✓	✓	✓	✓	✓	✓	✓	✓	✓	✓	✓	✓	✓	✓
440 VΔ; 50 Hz output	9	L2R	✓	✓	✓	✓	✓	✓	✓	✓	✓	✓	✓	✓	✓	✓
440 VΔ; 60 Hz output	9	L2X	✓	✓	✓	✓	✓	✓	✓	✓	✓	✓	✓	✓	✓	✓
460 VY; 50 Hz output	9	L2S	✓	✓	✓	✓	✓	✓	✓	✓	✓	✓	✓	✓	✓	✓
460 VY; 60 Hz output	9	L2E	○	○	○	○	○	○	○	○	○	○	○	○	○	○
460 VΔ; 50 Hz output	9	L2T	✓	✓	✓	✓	✓	✓	✓	✓	✓	✓	✓	✓	✓	✓
460 VΔ; 60 Hz output	9	L2F	○	○	○	○	○	○	○	○	○	○	○	○	○	○
575 VY; 50 Hz output	9	L2U	✓	✓	✓	✓	✓	✓	✓	✓	✓	✓	✓	✓	✓	✓
575 VY; 60 Hz output	9	L2L	✓	✓	✓	✓	✓	✓	✓	✓	✓	✓	✓	✓	✓	✓
575 VΔ; 50 Hz output	9	L2V	✓	✓	✓	✓	✓	✓	✓	✓	✓	✓	✓	✓	✓	✓
575 VΔ; 60 Hz output	9	L2M	✓	✓	✓	✓	✓	✓	✓	✓	✓	✓	✓	✓	✓	✓
<b>Non-standard voltage and/or frequencies</b>																
Non-standard winding for vol- tages between 200 and 690 V (voltages outside this range are available on request) <sup>3)</sup>	9	L1Y •	✓	✓	✓	✓	✓	✓	✓	✓	✓	✓	✓	✓	✓	✓

- Without additional charge
- ✓ With additional charge
- This order code only determines the price of the version – Additional plain text is required.

<sup>1)</sup> For Zones 21 and 22, for order codes **L1C, L1D, L1E, L1L, L1R, L1U, L1B** and **L1A** a rated voltage range is also marked on the rating plate.

<sup>2)</sup> The rating data for converter-fed operation is also provided in a table on the rating plate.

<sup>3)</sup> Plain text must be specified in the order: Voltage, frequency, circuit, required rated output in kW.

# IEC Squirrel-Cage Motors

## Explosion-proof motors

### Special versions

Special versions	Voltage code 11th position of the Order No.	Additional identifica- tion code with order code and plain text if required	Motor type frame size														
			56	63	71	80	90	100	112	132	160	180	200	225	250	280	315 S/M
<b>Self-ventilated motors in Zones 2, 21, 22 with type of protection "n" or protection against dust explosions – Cast-iron series 1LA6 and 1LG4</b>																	
<b>Voltage at 50 Hz</b>																	
220 VΔ/380 VY (440 VY at 60 Hz) (210 ... 230 VΔ/360 ... 400 VY); 50 Hz output <sup>1)</sup>	9	L1R	✓	✓	✓	✓	✓	✓	✓	✓	✓	✓	✓	✓	✓	✓	–
230 VΔ (220 ... 240 VΔ); 50 Hz output <sup>1)</sup>	9	L1E	○	○	○	○	○	○	○	○	○	○	○	○	○	○	–
380 VΔ/660 VY (440 VΔ at 60 Hz) (360 ... 400 VΔ/625 ... 695 VY); 50 Hz output <sup>1)</sup>	9	L1L	✓	✓	✓	✓	✓	✓	✓	✓	✓	✓	✓	✓	✓	✓	✓
415 VY (395 ... 435 VY); 50 Hz output <sup>1)</sup>	9	L1C	✓	✓	✓	✓	✓	✓	✓	✓	✓	✓	✓	✓	✓	✓	–
415 VΔ (395 ... 435 VΔ); 50 Hz output <sup>1)</sup>	9	L1D	✓	✓	✓	✓	✓	✓	✓	✓	✓	✓	✓	✓	✓	✓	✓
400 VY (380 ... 420 VY); 50 Hz output <sup>1)</sup>	9	L1A	○	○	○	○	○	○	○	○	○	○	○	○	○	○	–
400 VΔ (380 ... 420 VΔ); 50 Hz output <sup>1)</sup>	9	L1B	○	○	○	○	○	○	○	○	○	○	○	○	○	○	○
400 VΔ (460 VΔ bei 60 Hz) (380 ... 420 VΔ); 50 Hz output <sup>1)</sup>	9	L1U	○	○	○	○	○	○	○	○	○	○	○	○	○	○	○
400 VΔ 87 Hz output (2-pole to 4-pole only) <sup>2)</sup>	9	L3A	○	○	○	○	○	○	○	○	○	○	○	○	○	○	○
<b>Voltage at 60 Hz</b>																	
220 VΔ/380 VY; 50 Hz output	9	L2A	✓	✓	✓	✓	✓	✓	✓	✓	✓	✓	✓	✓	✓	✓	–
220 VΔ/380 VY; 60 Hz output	9	L2B	✓	✓	✓	✓	✓	✓	✓	✓	✓	✓	✓	✓	✓	✓	–
380 VΔ/660 VY; 50 Hz output	9	L2C	✓	✓	✓	✓	✓	✓	✓	✓	✓	✓	✓	✓	✓	✓	✓
380 VΔ/660 VY; 60 Hz output	9	L2D	✓	✓	✓	✓	✓	✓	✓	✓	✓	✓	✓	✓	✓	✓	✓
440 VY; 50 Hz output	9	L2Q	✓	✓	✓	✓	✓	✓	✓	✓	✓	✓	✓	✓	✓	✓	–
440 VY; 60 Hz output	9	L2W	✓	✓	✓	✓	✓	✓	✓	✓	✓	✓	✓	✓	✓	✓	–
440 VΔ; 50 Hz output	9	L2R	✓	✓	✓	✓	✓	✓	✓	✓	✓	✓	✓	✓	✓	✓	✓
440 VΔ; 60 Hz output	9	L2X	✓	✓	✓	✓	✓	✓	✓	✓	✓	✓	✓	✓	✓	✓	✓
460 VY; 50 Hz output	9	L2S	✓	✓	✓	✓	✓	✓	✓	✓	✓	✓	✓	✓	✓	✓	–
460 VY; 60 Hz output	9	L2E	○	○	○	○	○	○	○	○	○	○	○	○	○	○	–
460 VΔ; 50 Hz output	9	L2T	✓	✓	✓	✓	✓	✓	✓	✓	✓	✓	✓	✓	✓	✓	✓
460 VΔ; 60 Hz output	9	L2F	○	○	○	○	○	○	○	○	○	○	○	○	○	○	○
575 VY; 50 Hz output	9	L2U	✓	✓	✓	✓	✓	✓	✓	✓	✓	✓	✓	✓	✓	✓	–
575 VY; 60 Hz output	9	L2L	✓	✓	✓	✓	✓	✓	✓	✓	✓	✓	✓	✓	✓	✓	–
575 VΔ; 50 Hz output	9	L2V	✓	✓	✓	✓	✓	✓	✓	✓	✓	✓	✓	✓	✓	✓	✓
575 VΔ; 60 Hz output	9	L2M	○	○	○	○	○	○	○	○	○	○	○	○	○	○	○
<b>Non-standard voltage and/or frequencies</b>																	
Non-standard winding for vol- tages between 200 and 690 V (voltages outside this range are available on request) <sup>3)</sup>	9	L1Y •	✓	✓	✓	✓	✓	✓	✓	✓	✓	✓	✓	✓	✓	✓	✓

- Without additional charge
- ✓ With additional charge
- R. Possible on request
- Not possible
- This order code only determines the price of the version –  
Additional plain text is required.

<sup>1)</sup> For Zones 21 and 22, for order codes **L1C, L1D, L1E, L1L, L1R, L1U, L1B** and **L1A** a rated voltage range is also marked on the rating plate.

<sup>2)</sup> The rating data for converter-fed operation is also provided in a table on the rating plate.

<sup>3)</sup> Plain text must be specified in the order: Voltage, frequency, circuit, required rated output in kW.

# IEC Squirrel-Cage Motors

## Explosion-proof motors

### Special versions

Special versions	Voltage code 11th position of the Order No.	Additional identification code with order code and plain text if required	Motor type frame size																
			56	63	71	80	90	100	112	132	160	180	200	225	250	280	315 S/M	315 L	
<b>Self-ventilated motors in Zones 2, 21 and 22 with type of protection “n” or protection against dust explosions – Cast-iron series 1LG6</b>																			
													<b>1LG6 (cast-iron)</b>						
<b>Voltage at 50 Hz</b>																			
220 VΔ/380 VY (440 VY at 60 Hz) (210 ... 230 VΔ/360 ... 400 VY); 50 Hz output <sup>1)</sup>	9	L1R												✓	✓	✓	✓	✓	–
230 VΔ (220 ... 240 VΔ); 50 Hz output <sup>1)</sup>	9	L1E												○	○	○	○	○	–
380 VΔ/660 VY (440 VΔ at 60 Hz) (360 ... 400 VΔ/625 ... 695 VY); 50 Hz output <sup>1)</sup>	9	L1L												✓	✓	✓	✓	✓	✓
415 VY (395 ... 435 VY); 50 Hz output <sup>1)</sup>	9	L1C												✓	✓	✓	✓	✓	–
415 VΔ (395 ... 435 VΔ); 50 Hz output <sup>1)</sup>	9	L1D												✓	✓	✓	✓	✓	✓
400 VY (380 ... 420 VY); 50 Hz output <sup>1)</sup>	9	L1A												○	○	○	○	○	–
400 VΔ (380 ... 420 VΔ); 50 Hz output <sup>1)</sup>	9	L1B												○	○	○	○	○	○
400 VΔ (460 VΔ bei 60 Hz) (380 ... 420 VΔ); 50 Hz output <sup>1)</sup>	9	L1U												○	○	○	○	○	○
400 VΔ 87 Hz output (4-pole to 8-pole only) <sup>2)</sup>	9	L3A												O. R.	O. R.	O. R.	O. R.	O. R.	–
<b>Voltage at 60 Hz</b>																			
220 VΔ/380 VY; 50 Hz output	9	L2A												✓	✓	✓	✓	✓	–
220 VΔ/380 VY; 60 Hz output	9	L2B												✓	✓	✓	✓	✓	–
380 VΔ/660 VY; 50 Hz output	9	L2C												✓	✓	✓	✓	✓	✓
380 VΔ/660 VY; 60 Hz output	9	L2D												✓	✓	✓	✓	✓	✓
440 VY; 50 Hz output	9	L2Q												✓	✓	✓	✓	✓	–
440 VY; 60 Hz output	9	L2W												✓	✓	✓	✓	✓	–
440 VΔ; 50 Hz output	9	L2R												✓	✓	✓	✓	✓	✓
440 VΔ; 60 Hz output	9	L2X												✓	✓	✓	✓	✓	✓
460 VY; 50 Hz output	9	L2S												✓	✓	✓	✓	✓	–
460 VY; 60 Hz output	9	L2E												○	○	○	○	○	–
460 VΔ; 50 Hz output	9	L2T												✓	✓	✓	✓	✓	✓
460 VΔ; 60 Hz output	9	L2F												○	○	○	○	○	○
575 VY; 50 Hz output	9	L2U												✓	✓	✓	✓	✓	–
575 VY; 60 Hz output	9	L2L												✓	✓	✓	✓	✓	–
575 VΔ; 50 Hz output	9	L2V												✓	✓	✓	✓	✓	✓
575 VΔ; 60 Hz output	9	L2M												○	○	○	○	○	○
<b>Non-standard voltage and/or frequencies</b>																			
Non-standard winding for voltages between 200 and 690 V (voltages outside this range are available on request) <sup>3)</sup>	9	L1Y •												✓	✓	✓	✓	✓	✓

- Without additional charge
- ✓ With additional charge
- O. R. Possible on request
- Not possible
- This order code only determines the price of the version – Additional plain text is required.

<sup>1)</sup> For Zones 21 and 22, for order codes **L1C, L1D, L1E, L1L, L1R, L1U, L1B** and **L1A** a rated voltage range is also marked on the rating plate.

<sup>2)</sup> The rating data for converter-fed operation is also provided in a table on the rating plate.

<sup>3)</sup> Plain text must be specified in the order: Voltage, frequency, circuit, required rated output in kW.

# IEC Squirrel-Cage Motors

## Explosion-proof motors

### Special versions

#### Types of construction

Additional order codes for other types of construction or type of construction codes (without **-Z** supplement)

Order codes have been defined for some special types of construction. They are ordered by specifying the code digit **9** for the type of construction in the 12th position of the Order No. and the appropriate order code.

Special versions	Type of construction code 12th position of the Order No.	Additional identification code with order code and plain text if required	Motor type frame size													315 S/M	315 L	2-pole	4-, 6-, 8-pole
			56	63	71	80	90	100	112	132	160	180	200	225	250				
<b>Self-ventilated motors in Zone 1 with type of protection "e" – Aluminum series 1MA7</b>																			
<b>1MA7 (aluminum)</b>																			
<b>Without flange</b>																			
IM V5 with protective cover <sup>1) 2)</sup>	9	M1F	✓	✓	✓	✓	✓	✓	✓	✓	✓	✓	✓	✓	✓	✓	✓	✓	
<b>With standard flange</b>																			
IM V18 with protective cover <sup>1) 2)</sup>	9	M2A	✓	✓	✓	✓	✓	✓	✓	✓	✓	✓	✓	✓	✓	✓	✓	✓	
<b>With special flange</b>																			
IM V18 with protective cover <sup>1) 2)</sup>	9	M2B	✓	✓	✓	✓	✓	✓	✓	✓	✓	✓	✓	✓	✓	✓	✓	✓	
IM B34	9	M2C	✓	✓	✓	✓	✓	✓	✓	✓	✓	✓	✓	✓	✓	✓	✓	✓	
<b>Self-ventilated motors in Zone 1 with type of protection "e" – Cast-iron series 1MA6</b>																			
<b>1MA6 (cast-iron)</b>																			
<b>Without flange</b>																			
IM V6 <sup>1) 3)</sup>	9	M1E	–	–	–	–	–	–	–	–	–	–	–	–	–	–	–	✓ <sup>4)</sup>	○
IM V5 with protective cover <sup>1) 2) 3)</sup>	9	M1F	✓	✓	✓	✓	✓	✓	✓	✓	✓	✓	✓	✓	✓	✓	✓	✓ <sup>4)</sup>	✓
<b>With flange</b>																			
IM V3 <sup>1) 5)</sup>	9	M1G	–	–	–	–	–	–	–	✓	✓	✓	✓	✓	✓	✓	✓	–	–
<b>With special flange</b>																			
IM V18 with protective cover <sup>1) 2)</sup>	9	M2B	✓	✓	✓	✓	–	–	–	–	–	–	–	–	–	–	–	–	–
IM B34	9	M2C	✓	✓	✓	✓	–	–	–	–	–	–	–	–	–	–	–	–	–

- Without additional charge
- ✓ With additional charge
- Not possible

4

- 1) The following applies for explosion-proof motors: In the case of the types of construction with shaft extension down, the version "with protective cover" is required. For types of construction with shaft extension pointing upwards, a suitable cover must be implemented to prevent small parts from falling into the fan cover (see the standard IEC/EN 60079-0). The cover must not block the cooling air-flow.
- 2) The "Second shaft extension" option, order code **K16** is not possible.
- 3) If motors of frame sizes 180 M to 315 L are mounted on the wall, it is recommended that the motor feet are supported.

- 4) 60 Hz version is possible on request.
- 5) 1MA6 motors of frame sizes 225 S to 315 M are supplied with two screw-in eyebolts in accordance with IM B5, whereby one can be relocated in accordance with IM V1 or IM V3. It is important to note that stress must not be applied perpendicular to the ring plane.

# IEC Squirrel-Cage Motors

## Explosion-proof motors

### Special versions

Special versions	Type of construction code 12th position of the Order No.	Additional identification code with order code and plain text if required	Motor type frame size													
			56	63	71	80	90	100	112	132	160	180	200	225	250	280
<b>Self-ventilated motors in Zone 1 with type of protection "de" – Cast-iron series 1MJ6 and 1MJ7</b>																
			<b>1MJ6 (cast-iron)</b>						<b>1MJ7 (cast-iron)</b>							
<b>Without flange</b>																
IM V5 with protective cover <sup>1) 2) 3)</sup>	<b>9</b>	<b>M1F</b>	✓	✓	✓	✓	✓	✓	✓	✓	✓	✓	✓	✓	✓	✓
<b>With flange</b>																
IM V3 <sup>1) 4)</sup>	<b>9</b>	<b>M1G</b>	–	–	–	–	–	–	–	–	–	✓	✓	✓	✓	✓
<b>With standard flange</b>																
IM V18 with protective cover <sup>1) 2)</sup>	<b>9</b>	<b>M2A</b>	✓	✓	✓	–	–	–	–	–	–	–	–	–	–	–
<b>With special flange</b>																
IM V18 with protective cover <sup>1) 2)</sup>	<b>9</b>	<b>M2B</b>	✓	✓	–	–	–	–	–	–	–	–	–	–	–	–
IM B34	<b>9</b>	<b>M2C</b>	✓	✓	–	–	–	–	–	–	–	–	–	–	–	–

- ✓ With additional charge  
 – Not possible

<sup>1)</sup> The following applies for explosion-proof motors: In the case of the types of construction with shaft extension down, the version "with protective cover" is required. For types of construction with shaft extension pointing upwards, a suitable cover must be implemented to prevent small parts from falling into the fan cover (see the standard IEC/EN 60079-0). The cover must not block the cooling air-flow.

<sup>2)</sup> The "Second shaft extension" option, order code **K16** is not possible.

<sup>3)</sup> If motors of frame sizes 180 M to 315 M are mounted on the wall, it is recommended that the motor feet are supported.

<sup>4)</sup> 1MJ7 motors of frame sizes 225 S to 315 M are supplied with two screw-in eyebolts in accordance with IM B5, whereby one can be relocated in accordance with IM V1 or IM V3. It is important to note that stress must not be applied perpendicular to the ring plane.

# IEC Squirrel-Cage Motors

## Explosion-proof motors

### Special versions

Special versions	Type of construction code 12th position of the Order No.	Additional identification code with order code and plain text if required	Motor type frame size																			
			56	63	71	80	90	100	112	132	160	180	200	225	250	280	315 S/M	315 L	2-pole	4-, 6-, 8-pole		
<b>Self-ventilated motors in Zones 2, 21 and 22 with type of protection "n" or protection against dust explosions – Aluminum series 1LA7 and 1LA5</b>																						
			<b>1LA7 (aluminum) <sup>1)</sup></b>								<b>1LA5 (aluminum) <sup>1)</sup></b>											
<b>Without flange</b>																						
IM V5 with protective cover <sup>2) 3)</sup>	9	M1F	–	✓	✓	✓	✓	✓	✓	✓	✓	✓	✓	✓	✓	✓	✓	✓	✓	✓		
<b>With flange</b>																						
IM V3 <sup>2) 4)</sup>	9	M1G	–	–	–	–	–	–	–	–	–	–	–	–	–	–	–	–	–	–		
<b>With standard flange</b>																						
IM V18 with protective cover <sup>2) 3)</sup>	9	M2A	–	✓	✓	✓	✓	✓	✓	✓	✓	✓	✓	✓	–	–	–	–	–	–		
<b>With special flange</b>																						
IM V18 with protective cover <sup>2) 3)</sup>	9	M2B	–	✓	✓	✓	✓	✓	✓	✓	✓	✓	✓	✓	–	–	–	–	–	–		
IM B34	9	M2C	✓	✓	✓	✓	✓	✓	✓	✓	✓	✓	✓	✓	–	–	–	–	–	–		
<b>Self-ventilated motors in Zones 2, 21 and 22 with type of protection "n" or protection against dust explosions – Aluminum series 1LA9</b>																						
			<b>1LA9 (aluminum)</b>																			
<b>Without flange</b>																						
IM V5 with protective cover <sup>2) 3)</sup>	9	M1F	–	✓	✓	✓	✓	✓	✓	✓	✓	✓	✓	✓	✓	✓	✓	✓	✓	✓		
<b>With flange</b>																						
IM V3	9	M1G	–	–	–	–	–	–	–	–	–	–	–	–	–	–	–	–	–	–		
<b>With standard flange</b>																						
IM V18 with protective cover <sup>2) 3)</sup>	9	M2A	–	✓	✓	✓	✓	✓	✓	✓	✓	✓	✓	✓	–	–	–	–	–	–		
<b>With special flange</b>																						
IM V18 with protective cover <sup>2) 3)</sup>	9	M2B	–	✓	✓	✓	✓	✓	✓	✓	✓	✓	✓	✓	–	–	–	–	–	–		
IM B34	9	M2C	✓	✓	✓	✓	✓	✓	✓	✓	✓	✓	✓	✓	–	–	–	–	–	–		
<b>Self-ventilated motors in Zones 2, 21 and 22 with type of protection "n" or protection against dust explosions – Cast-iron series 1LA6 and 1LG4</b>																						
			<b>1LA6 (cast-iron)</b>									<b>1LG4 (cast-iron)</b>										
<b>Without flange</b>																						
IM V6 <sup>2) 6)</sup>	9	M1E	–	–	–	–	–	–	–	–	–	–	–	–	–	–	–	–	–	–		
IM V5 with protective cover <sup>2) 3) 6)</sup>	9	M1F	✓	✓	✓	✓	✓	✓	✓	✓	✓	✓	✓	✓	✓	✓	✓	✓	✓	✓		
<b>With flange</b>																						
IM V3 <sup>2) 7)</sup>	9	M1G	–	–	–	–	–	–	–	–	–	–	–	–	–	–	–	–	–	–		
<b>With standard flange</b>																						
IM V18 with protective cover <sup>2) 3)</sup>	9	M2A	✓	✓	✓	✓	✓	✓	✓	✓	✓	✓	✓	✓	–	–	–	–	–	–		
<b>With special flange</b>																						
IM V18 with protective cover <sup>2) 3)</sup>	9	M2B	✓	✓	✓	✓	✓	✓	✓	✓	✓	✓	✓	✓	–	–	–	–	–	–		
IM B34	9	M2C	✓	✓	✓	✓	✓	✓	✓	✓	✓	✓	✓	✓	–	–	–	–	–	–		
<b>Self-ventilated motors in Zones 2, 21 and 22 with type of protection "n" or protection against dust explosions – Cast-iron series 1LG6</b>																						
			<b>1LG6 (cast-iron)</b>																			
<b>Without flange</b>																						
IM V6 <sup>6)</sup>	9	M1E	–	–	–	–	–	–	–	–	–	–	–	–	–	–	–	–	–	–		
IM V5 with protective cover <sup>2) 3) 6)</sup>	9	M1F	✓	✓	✓	✓	✓	✓	✓	✓	✓	✓	✓	✓	✓	✓	✓	✓	✓	✓		
<b>With flange</b>																						
IM V3 <sup>2) 7)</sup>	9	M1G	✓	✓	✓	✓	✓	✓	✓	✓	✓	✓	✓	✓	✓	✓	✓	✓	✓	✓		

- Without additional charge  
 ✓ With additional charge  
 – Not possible

- <sup>1)</sup> Zone 2 is not possible for motor series 1LA5 and motor series 1LA7 for frame size 56.  
<sup>2)</sup> The following applies for explosion-proof motors: In the case of the types of construction with shaft extension down, the version "with protective cover" is required. For types of construction with shaft extension pointing upwards, a suitable cover must be implemented to prevent small parts from falling into the fan cover (see the standard IEC/EN 60079-0). The cover must not block the cooling air-flow.  
<sup>3)</sup> The "Second shaft extension" option, order code **K16** is not possible.  
<sup>4)</sup> For frame sizes 180 M to 225 M, the 1LA5 motors can be supplied with two additional eyebolts; state identification code "**-Z**" and order code **K32**.

- <sup>5)</sup> 60 Hz version is possible on request.  
<sup>6)</sup> If motors of frame sizes 180 M to 315 L are mounted on the wall, it is recommended that the motor feet are supported.  
<sup>7)</sup> 1LG4/1LG6 motors of frame sizes 225 S to 315 M are supplied with two screw-in eyebolts in accordance with IM B5, whereby one can be relocated in accordance with IM V1 or IM V3. It is important to note that stress must not be applied perpendicular to the ring plane.



# IEC Squirrel-Cage Motors

## Explosion-proof motors

Special versions

### Options

Options or order codes (supplement **-Z** is required)

Special versions	Additional identification code <b>-Z</b> with order code and plain text if required	Motor type frame size														
		56	63	71	80	90	100	112	132	160	180	200	225	250	280	315
<b>Self-ventilated motors in Zone 1 with type of protection "e" – Aluminum series 1MA7</b>																
<b>Design for Zones 1, 2, 21 and 22 according to ATEX</b>																
T1/T2 on rating plate <sup>1)</sup>	<b>C30</b>		–	–	–	–	–	–	○	○						
<b>Motor protection</b>																
Motor protection with PTC thermistors with 3 embedded temperature sensors for tripping <sup>2)</sup>	<b>A11</b>		✓	✓	✓	✓	✓	✓	✓	✓						
Motor protection with PTC thermistors with 6 embedded temperature sensors for alarm and tripping <sup>2)</sup>	<b>A12</b>		✓	✓	✓	✓	✓	✓	✓	✓						
<b>Motor connection and connection box</b>																
Connection box on RHS	<b>K09</b>		–	–	✓	✓	✓	✓	✓	✓						
Connection box on LHS	<b>K10</b>		–	–	✓	✓	✓	✓	✓	✓						
Rotation of the connection box through 90°, entry from DE	<b>K83</b>		✓	✓	✓	✓	✓	✓	✓	✓						
Rotation of the connection box through 90°, entry from NDE	<b>K84</b>		✓	✓	✓	✓	✓	✓	✓	✓						
Rotation of connection box through 180°	<b>K85</b>		✓	✓	✓	✓	✓	○	○	○	○					
<b>Windings and insulation</b>																
Increased air humidity/temperature with 30 to 60 g water per m <sup>3</sup> of air	<b>C19</b>		✓	✓	✓	✓	✓	✓	✓	✓						
Temperature class 155 (F), used acc. to 130 (B), coolant temperature 45 °C, derating approx. 4 % <sup>3)</sup>	<b>C22</b>		✓	✓	✓	✓	✓	✓	✓	✓						
Temperature class 155 (F), used acc. to 130 (B), coolant temperature 50 °C, derating approx. 8 % <sup>3)</sup>	<b>C23</b>		✓	✓	✓	✓	✓	✓	✓	✓						
Temperature class 155 (F), used acc. to 130 (B), coolant temperature 55 °C, derating approx. 13 % <sup>3)</sup>	<b>C24</b>		✓	✓	✓	✓	✓	✓	✓	✓						
Temperature class 155 (F), used acc. to 130 (B), coolant temperature 60 °C, derating approx. 18 % <sup>3)</sup>	<b>C25</b>		✓	✓	✓	✓	✓	✓	✓	✓						
Increased air humidity/temperature with 60 to 100 g water per m <sup>3</sup> of air	<b>C26</b>		✓	✓	✓	✓	✓	✓	✓	✓						
<b>Colors and paint finish</b>																
Special finish in RAL 7030 stone gray			□	□	□	□	□	□	□	□						
Special finish in other standard RAL colors: RAL 1002, 1013, 1015, 1019, 2003, 2004, 3000, 3007, 5007, 5009, 5010, 5012, 5015, 5017, 5018, 5019, 6011, 6019, 6021, 7000, 7001, 7004, 7011, 7016, 7022, 7031, 7032, 7033, 7035, 9001, 9002, 9005 Page 0/18	<b>Y54 •</b> and special finish RAL ....		✓	✓	✓	✓	✓	✓	✓	✓						
Special finish in special RAL colors: For RAL colors, see "Special finish in special RAL colors" Page 0/19	<b>Y51 •</b> and special finish RAL ....		✓	✓	✓	✓	✓	✓	✓	✓						
Offshore special finish	<b>M91</b>		O. R.	O. R.	O. R.	O. R.	O. R.	O. R.	O. R.	O. R.						
Unpainted (only cast iron parts primed)	<b>K23</b>		○	○	○	○	○	○	○	○						
Unpainted, only primed	<b>K24</b>		✓	✓	✓	✓	✓	✓	✓	✓						

For legend and footnotes, see Page 4/95.

# IEC Squirrel-Cage Motors

## Explosion-proof motors

### Special versions

Special versions	Additional identification code -Z with order code and plain text if required	Motor type frame size													
		56	63	71	80	90	100	112	132	160	180	200	225	250	280
<b>Self-ventilated motors in Zone 1 with type of protection "e" – Aluminum series 1MA7</b>															
<b>1MA7 (aluminum)</b>															
<b>Mechanical design and degrees of protection</b>															
Drive-end seal for flange-mounting motors with an oil-tightness of up to 0.1 bar Not possible for IM V3 type of construction	<b>K17</b>	✓	✓	✓	✓	✓	✓	✓	✓	✓					
Low-noise version for 2-pole motors with clockwise direction of rotation <sup>4)</sup>	<b>K37</b>	–	–	–	–	–	–	–	✓	✓					
Low-noise version for 2-pole motors with counter-clockwise direction of rotation <sup>4)</sup>	<b>K38</b>	–	–	–	–	–	–	–	✓	✓					
IP65 degree of protection	<b>K50</b>	✓	✓	✓	✓	✓	✓	✓	✓	✓					
IP56 degree of protection (non-heavy-sea)	<b>K52</b>	✓	✓	✓	✓	✓	✓	✓	✓	✓					
Vibration-proof version	<b>L03</b>	✓	✓	✓	✓	✓	✓	✓	✓	✓					
Condensation drainage holes <sup>5)</sup>	<b>L12</b>	✓	✓	✓	✓	✓	✓	✓	✓	✓					
Rust-resistant screws (externally)	<b>M27</b>	–	–	✓	✓	✓	✓	✓	✓	✓					
<b>Coolant temperature and site altitude</b>															
Coolant temperature –40 °C to +40 °C for EX motors <sup>6)</sup>	<b>D19</b>	✓	✓	✓	✓	✓	✓	✓	✓	✓					
<b>Designs in accordance with standards and specifications</b>															
CCC China Compulsory Certification <sup>7)</sup>	<b>D01</b>	✓	✓	✓	✓	–	–	–	–	–					
VIK version	<b>K30</b>	✓	✓	✓	✓	✓	✓	✓	✓	✓					
<b>Bearings and lubrication</b>															
Bearing design for increased cantilever forces	<b>K20</b>	–	–	–	–	✓	✓	✓	✓	✓					
Regreasing device	<b>K40</b>	–	–	–	–	✓	✓	✓	✓	✓					
Located bearing DE	<b>K94</b>	✓	✓	✓	✓	✓	✓	✓	✓	✓					
Located bearing NDE	<b>L04</b>	✓	✓	✓	✓	✓	✓	✓	✓	✓				□	
<b>Balance and vibration quantity</b>															
Vibration quantity A		□	□	□	□	□	□	□	□	□					
Vibration quantity B	<b>K02</b>	✓	✓	✓	✓	✓	✓	✓	✓	✓					
Full key balancing	<b>L68</b>	✓	✓	✓	✓	✓	✓	✓	✓	✓					
Balancing without key	<b>M37</b>	✓	✓	✓	✓	✓	✓	✓	✓	✓					
<b>Shaft and rotor</b>															
Concentricity of shaft extension, coaxiality and linear movement in accordance with DIN 42955 Tolerance R for flange-mounting motors <sup>8)</sup>	<b>K04</b>	✓	✓	✓	✓	✓	✓	✓	✓	✓					
Second standard shaft extension <sup>9)</sup>	<b>K16</b>	✓	✓	✓	✓	✓	✓	✓	✓	✓					
Shaft extension with standard dimensions without featherkey way	<b>K42</b>	✓	✓	✓	✓	✓	✓	✓	✓	✓					
Concentricity of shaft extension in accordance with DIN 42955 Tolerance R	<b>L39</b>	✓	✓	✓	✓	✓	✓	✓	✓	✓					
Non-standard cylindrical shaft extension <sup>10)</sup>	<b>Y55 •</b> and identification code	✓	✓	✓	✓	✓	✓	✓	✓	✓					

For legend and footnotes, see Page 4/95.

# IEC Squirrel-Cage Motors

## Explosion-proof motors

### Special versions

Special versions	Additional identification code -Z with order code and plain text if required	Motor type frame size														
		56	63	71	80	90	100	112	132	160	180	200	225	250	280	315
<b>Self-ventilated motors in Zone 1 with type of protection "e" – Aluminum series 1MA7</b>																
<b>1MA7 (aluminum)</b>																
<b>Heating and ventilation</b>																
Metal external fan	<b>K35</b>		–	–	–	–	✓	✓	✓	✓						
<b>Rating plate and extra rating plates</b>																
Second lubricating plate, supplied loose	<b>B06</b>		–	–	–	–	✓	✓	✓	✓						
Second rating plate, loose	<b>K31</b>		✓	✓	✓	✓	✓	✓	✓	✓	✓	✓	✓	✓	✓	✓
Extra rating plate or rating plate with deviating rating plate data	<b>Y80 •</b> and identification code		✓	✓	✓	✓	✓	✓	✓	✓	✓	✓	✓	✓	✓	✓
Extra rating plate with identification code	<b>Y82 •</b> and identification code		✓	✓	✓	✓	✓	✓	✓	✓	✓	✓	✓	✓	✓	✓
Additional information on rating plate and on package label (maximum of 20 characters)	<b>Y84 •</b> and identification code		✓	✓	✓	✓	✓	✓	✓	✓	✓	✓	✓	✓	✓	✓
<b>Packaging, safety notes, documentation and test certificates</b>																
Acceptance test certificate 3.1 according to EN 10204	<b>B02</b>		✓	✓	✓	✓	✓	✓	✓	✓	✓	✓	✓	✓	✓	✓
Operating instructions German/English enclosed in print	<b>B23</b>		□	□	□	□	□	□	□	□	□	□	□	□	□	□
Wire-lattice pallet	<b>L99</b>		○	○	○	○	○	○	○	○	○	○	○	○	○	○

- Standard version
- Without additional charge
- This order code only determines the price of the version – Additional plain text is required.
- R. Possible on request
- ✓ With additional charge
- Not possible

- 1) 2-pole motors 1 MA frame sizes 132 to 160 are designed with double rating plate (T1/T2 and T3) as standard. For motor versions with order codes **A11/A12** or with voltage code "9" T3-output is then stamped on the rating plate as standard. Alternatively, "T1/T2-output on the rating plate" can be stamped – order code **C30**
- 2) Evaluation with associated 3RN1 tripping unit (see Catalog LV 1) is recommended. When used in hazardous areas, a certified tripping unit is required. Motor protection by means of PTC thermistor as sole protection available on request.
- 3) The maximum certified output will be supplied.
- 4) 1MA7 motors are up to 80 mm longer than normal. A second shaft extension is not possible.
- 5) Supplied with the condensation drainage holes sealed at the drive end DE and non-drive end NDE for IP55, IP56 and IP65 degrees of protection. If condensation drainage holes are required in motors of the IM B6, IM B7 or IM B8 type of construction (feet located on side or top), it is necessary to relocate the bearing plates at the drive end (DE) and non-drive end (NDE) so that the condensation drainage holes situated between the feet on delivery are underneath.
- 6) Not possible in combination with vibration-proof version, order code **L03**.
- 7) CCC certification is required for
  - 2-pole motors  $\leq 2.2$  kW
  - 4-pole motors  $\leq 1.1$  kW
  - 6-pole motors  $\leq 0.75$  kW
  - 8-pole motors  $\leq 0.55$  kW
- 8) Can be combined with deep-groove bearings of series 60... 62... and 63... Not possible in combination with parallel roller bearings (e.g. bearings for increased cantilever forces, order code **K20**).
- 9) Not possible for low-noise version (2-pole) for frame sizes 132 S to 160 L. Version with protective cover not possible.
- 10) When motors are ordered that have a longer or shorter shaft extension than normal, the required position and length of the featherkey way must be specified in a sketch. It must be ensured that only featherkeys in accordance with DIN 6885, Form A are permitted to be used. The featherkey way is positioned centrally on the shaft extension. The length is defined by the manufacturer normatively. Not valid for: Conical shafts, non-standard threaded journals, non-standard shaft tolerances, friction welded journals, extremely "thin" shafts, special geometry dimensions (e.g. square journals), hollow shafts. Valid for non-standard shaft extensions DE or NDE. The featherkeys are supplied in every case.
  - For order codes **Y55** and **K16**:
    - Dimensions D and DA  $\leq$  internal diameter of roller bearing (see dimension tables under "Dimensions")
    - Dimensions E and EA  $\leq 2 \times$  length E (normal) of the shaft extension

# IEC Squirrel-Cage Motors

## Explosion-proof motors

### Special versions

Special versions	Additional identification code <b>-Z</b> with order code and plain text if required	Motor type frame size														
		56	63	71	80	90	100	112	132	160	180	200	225	250	280	315
<b>Self-ventilated motors in Zone 1 with type of protection "e" – Cast-iron series 1MA6</b>																
<b>Design for Zones 1, 2, 21 and 22 according to ATEX</b>																
T1/T2 on rating plate <sup>1)</sup>	<b>C30</b>															
<b>Motor protection</b>																
Motor protection with PTC thermistors with 3 embedded temperature sensors for tripping <sup>2)</sup>	<b>A11</b>															
Motor protection with PTC thermistors with 6 embedded temperature sensors for alarm and tripping <sup>2)</sup>	<b>A12</b>															
Installation of 2 PT 100 screw-in resistance thermometers (basic circuit) for rolling-contact bearings <sup>2)</sup>	<b>A72</b>												O. R.	O. R.	O. R.	O. R.
Installation of 2 PT100 screw-in resistance thermometers (3-wire circuit) for rolling-contact bearings	<b>A78</b>												O. R.	O. R.	O. R.	O. R.
<b>Motor connection and connection box</b>																
Connection box on RHS	<b>K09</b>															
Connection box on LHS	<b>K10</b>															
Connection box in cast-iron version	<b>K15</b>															
Rotation of the connection box through 90°, entry from DE	<b>K83</b>															
Rotation of the connection box through 90°, entry from NDE	<b>K84</b>															
Rotation of connection box through 180°	<b>K85</b>															
Next larger connection box	<b>L00</b>															
Auxiliary connection box 1XB3 020	<b>L97</b>															
<b>Windings and insulation</b>																
Increased air humidity/temperature with 30 to 60 g water per m <sup>3</sup> of air	<b>C19</b>															
Temperature class 155 (F), used acc. to 130 (B), coolant temperature 45 °C, derating approx. 4 % <sup>3)</sup>	<b>C22</b>															
Temperature class 155 (F), used acc. to 130 (B), coolant temperature 50 °C, derating approx. 8 % <sup>3)</sup>	<b>C23</b>															
Temperature class 155 (F), used acc. to 130 (B), coolant temperature 55 °C, derating approx. 13 % <sup>3)</sup>	<b>C24</b>															
Temperature class 155 (F), used acc. to 130 (B), coolant temperature 60 °C, derating approx. 18 % <sup>3)</sup>	<b>C25</b>															
Increased air humidity/temperature with 60 to 100 g water per m <sup>3</sup> of air	<b>C26</b>															

4

For legend, see Page 4/98, for footnotes, see Page 4/99.

# IEC Squirrel-Cage Motors

## Explosion-proof motors

### Special versions

Special versions	Additional identification code <b>-Z</b> with order code and plain text if required	Motor type frame size														
		56	63	71	80	90	100	112	132	160	180	200	225	250	280	315
<b>Self-ventilated motors in Zone 1 with type of protection "e" – Cast-iron series 1MA6</b>																
<b>1MA6 (cast-iron)</b>																
<b>Colors and paint finish</b>																
Standard finish in RAL 7030 stone gray												□	□	□	□	
Standard finish in other standard RAL colors: RAL 1002, 1013, 1015, 1019, 2003, 2004, 3000, 3007, 5007, 5009, 5010, 5012, 5015, 5017, 5018, 5019, 6011, 6019, 6021, 7000, 7001, 7004, 7011, 7016, 7022, 7031, 7032, 7033, 7035, 9001, 9002, 9005 Page 0/18	<b>Y53 •</b> and standard finish RAL ....											✓	✓	✓	✓	
Special finish in RAL 7030 stone gray <sup>4)</sup>	<b>K26</b>						□	□	□	□	□	□	□	□	□	□
Special finish in other standard RAL colors: RAL 1002, 1013, 1015, 1019, 2003, 2004, 3000, 3007, 5007, 5009, 5010, 5012, 5015, 5017, 5018, 5019, 6011, 6019, 6021, 7000, 7001, 7004, 7011, 7016, 7022, 7031, 7032, 7033, 7035, 9001, 9002, 9005 Page 0/18	<b>Y54 •</b> and special finish RAL ....						✓	✓	✓	✓	✓	✓	✓	✓	✓	✓
Special finish in special RAL colors: For RAL colors, see "Special finish in special RAL colors" Page 0/19	<b>Y51 •</b> and special finish RAL ....						✓	✓	✓	✓	✓	✓	✓	✓	✓	✓
Offshore special finish	<b>M91</b>						O. R.	O. R.	O. R.	O. R.	O. R.	O. R.	O. R.	O. R.	O. R.	O. R.
Sea air resistant special finish	<b>M94</b>						O. R.	O. R.	O. R.	O. R.	O. R.	O. R.	O. R.	O. R.	O. R.	O. R.
Unpainted (only cast iron parts primed)	<b>K23</b>						○	○	○	○	○	○	○	○	○	○
Unpainted, only primed	<b>K24</b>						✓	✓	✓	✓	✓	✓	✓	✓	✓	✓
<b>Mechanical design and degrees of protection</b>																
Drive-end seal for flange-mounting motors with an oil-tightness of up to 0.1 bar Not possible for type of construction IM V3; with frame size 180 M and above, only possible for 4-pole to 6-pole motors	<b>K17</b>						✓	✓	✓	✓	✓	✓	✓	✓	✓	✓
Low-noise version for 2-pole motors with clockwise direction of rotation <sup>5)</sup>	<b>K37</b>						–	–	✓	✓	✓	✓	✓	✓	✓	✓
Low-noise version for 2-pole motors with counter-clockwise direction of rotation <sup>5)</sup>	<b>K38</b>						–	–	✓	✓	✓	✓	✓	✓	✓	✓
IP65 degree of protection	<b>K50</b>						✓	✓	✓	✓	✓	✓	✓	✓	✓	✓
IP56 degree of protection (non-heavy-sea)	<b>K52</b>						✓	✓	✓	✓	✓	✓	✓	✓	✓	✓
Vibration-proof version	<b>L03</b>						✓	✓	✓	✓	–	–	–	–	–	–
Condensation drainage holes <sup>6)</sup>	<b>L12</b>						✓	✓	✓	✓	✓	–	–	–	–	–
Rust-resistant screws (externally)	<b>M27</b>						✓	✓	✓	✓	✓	✓	✓	✓	✓	✓
<b>Coolant temperature and site altitude</b>																
Coolant temperature –40 °C to +40 °C for EX motor <sup>7)</sup>	<b>D19</b>						✓	✓	✓	✓	✓	✓	✓	✓	✓	✓
<b>Designs in accordance with standards and specifications</b>																
VIK version	<b>K30</b>						✓	✓	✓	✓	✓	✓	✓	✓	✓	✓
<b>Bearings and lubrication</b>																
Measuring nipple for SPM shock pulse measurement for bearing inspection	<b>G50</b>						–	–	–	–	✓	✓	✓	✓	✓	✓
Bearing design for increased cantilever forces <sup>8)</sup>	<b>K20</b>						✓	✓	✓	✓	✓	✓	✓	✓	✓	✓
Regreasing device	<b>K40</b>						✓	✓	✓	✓	✓	✓	✓	✓	□	□
Located bearing DE	<b>K94</b>						✓	✓	✓	✓	✓	–	–	–	–	–
Located bearing NDE	<b>L04</b>						✓	✓	✓	□	–	–	–	–	–	–

# IEC Squirrel-Cage Motors

## Explosion-proof motors

### Special versions

Special versions	Additional identification code <b>-Z</b> with order code and plain text if required	Motor type frame size														
		56	63	71	80	90	100	112	132	160	180	200	225	250	280	315
<b>Self-ventilated motors in Zone 1 with type of protection "e" – Cast-iron series 1MA6</b>																
<b>1MA6 (cast-iron)</b>																
<b>Balance and vibration quantity</b>																
Vibration quantity A							☐	☐	☐	☐	☐	☐	☐	☐	☐	☐
Vibration quantity B	<b>K02</b>						✓	✓	✓	✓	✓	✓	✓ <sup>9)</sup>	✓ <sup>9)</sup>	✓ <sup>9)</sup>	✓ <sup>9)</sup>
Full key balancing	<b>L68</b>						✓	✓	✓	✓	✓	✓	✓	✓	✓	✓
Balancing without key	<b>M37</b>						✓	✓	✓	✓	✓	✓	✓	✓	✓	✓
<b>Shaft and rotor</b>																
Concentricity of shaft extension, coaxiality and linear movement in accordance with DIN 42955 Tolerance R for flange-mounting motors <sup>9)</sup>	<b>K04</b>						✓	✓	✓	✓	✓	✓	✓	✓	✓	✓
Second standard shaft extension <sup>10)</sup>	<b>K16</b>						✓	✓	✓	✓	✓	✓	✓	✓	✓	✓
Shaft extension with standard dimensions without featherkey way	<b>K42</b>						✓	✓	✓	✓	✓	✓	✓	✓	✓	✓
Concentricity of shaft extension in accordance with DIN 42955 Tolerance R	<b>L39</b>						✓	✓	✓	✓	✓	✓	✓	✓	✓	✓
Non-standard cylindrical shaft extension <sup>11)</sup>	<b>Y55 •</b> and identification code						✓	✓	✓	✓	✓	✓	✓	✓	✓	✓
<b>Heating and ventilation</b>																
Cast-iron fan cover	<b>K34</b>						–	–	–	–	–	–	✓	✓	✓	✓
Metal external fan	<b>K35</b>						✓	✓	✓	✓	✓	✓	✓	✓	✓	✓
Anti-condensation heaters for 230 V	<b>K45</b>						–	–	–	–	–	–	✓	✓	✓	✓
Anti-condensation heaters for 115 V	<b>K46</b>						–	–	–	–	–	–	✓	✓	✓	✓
<b>Rating plate and extra rating plates</b>																
Second lubricating plate, supplied loose	<b>B06</b>						✓	✓	✓	✓	✓	✓	✓	✓	✓	✓
Second rating plate, loose	<b>K31</b>						✓	✓	✓	✓	✓	✓	✓	✓	✓	✓
Extra rating plate or rating plate with deviating rating plate data	<b>Y80 •</b> and identification code						✓	✓	✓	✓	✓	✓	✓	✓	✓	✓
Extra rating plate with identification code	<b>Y82 •</b> and identification code						✓	✓	✓	✓	✓	✓	✓	✓	✓	✓
Additional information on rating plate and on package label (maximum of 20 characters)	<b>Y84 •</b> and identification code						✓	✓	✓	✓	✓	✓	✓	✓	✓	✓
<b>Packaging, safety notes, documentation and test certificates</b>																
Acceptance test certificate 3.1 according to EN 10204	<b>B02</b>						✓	✓	✓	✓	✓	✓	✓	✓	✓	✓
Operating instructions German/English enclosed in print	<b>B23</b>						☐	☐	☐	☐	☐	☐	☐	☐	☐	☐
Wire-lattice pallet	<b>L99</b>						○	○	○	○	○	○	–	–	–	–

- ☐ Standard version
- Without additional charge
- This order code only determines the price of the version – Additional plain text is required.
- , R. Possible on request
- ✓ With additional charge
- Not possible

For footnotes, see Page 4/99.

- 1) 2-pole motors 1MA frame sizes 132 to 160 are designed with double rating plate (T1/T2 and T3) as standard. For motor versions with order codes **A11/A12** or with voltage code "9" T3-output is then stamped on the rating plate as standard. Alternatively, "T1/T2-output on the rating plate" can be stamped – order code **C30**
- 2) Evaluation with associated 3RN1 tripping unit (see Catalog LV 1) is recommended. When used in hazardous areas, a certified tripping unit is required. Motor protection with PTC thermistors is available as sole protection up to frame size 160 L on request. With frame size 180 M and above, it is not permitted as sole protection; motor protection switch is required.
- 3) The maximum certified output will be supplied.
- 4) For frame sizes 100 to 200, do not specify an order code. Order code is only necessary for frame sizes 225 to 315.
- 5) 1MA6 motors are up to 80 mm longer than normal. A second shaft extension is not possible.
- 6) Supplied with the condensation drainage holes sealed at the drive end DE and non-drive end NDE for IP55, IP56 and IP65 degrees of protection. If condensation drainage holes are required in motors of the IM B6, IM B7 or IM B8 type of construction (feet located on side or top), it is necessary to relocate the bearing plates at the drive end (DE) and non-drive end (NDE) so that the condensation drainage holes situated between the feet on delivery are underneath.
- 7) Not possible in combination with vibration-proof version, order code **L03**.
- 8) Not possible for 2-pole 1MA6 motors, frame size 315 L in vertical type of construction; bearings for increased cantilever forces for vibration quantity level B are available on request for 1MA6 motors of frame size 225 M and above. Not possible for 1MA6 motors of frame size 225 M and above in combination with concentricity of shaft extension, coaxiality and linear movement according to DIN 42955 tolerance R for flange-mounting types.
- 9) Can be combined with deep-groove bearings of series 60... 62.. and 63... Not possible in combination with parallel roller bearings (e.g. bearings for increased cantilever forces, order code **K20**).
- 10) For motors of frame size 180 M and above in vertical type of construction in version with second shaft extension on request. Not possible for low-noise version (2-pole) for frame sizes 132 S to 160 L. Version with protective cover not possible.
- 11) When motors are ordered that have a longer or shorter shaft extension than normal, the required position and length of the featherkey way must be specified in a sketch. It must be ensured that only featherkeys in accordance with DIN 6885, Form A are permitted to be used. The featherkey way is positioned centrally on the shaft extension. The length is defined by the manufacturer normatively. Not applicable for: Conical shafts, non-standard threaded journals, non-standard shaft tolerances, friction welded journals, extremely "thin" shafts, special geometry dimensions (e.g. square journals), hollow shafts. Valid for non-standard shaft extensions DE or NDE. The featherkeys are supplied in every case.  
 For order codes **Y55** and **K16**:  
 – Dimensions D and DA  $\leq$  Inner diameter of roller bearing (see tables under "Dimensions")  
 – Dimensions E and EA  $\leq 2 \times$  Length E (normal) of the shaft extension  
 For explanation of the order codes, see catalog part 0 "Introduction".

# IEC Squirrel-Cage Motors

## Explosion-proof motors

### Special versions

Special versions	Additional identification code <b>-Z</b> with order code and plain text if required	Motor type frame size															
		56	63	71	80	90	100	112	132	160	180	200	225	250	280	315	
<b>Self-ventilated motors in Zone 1 with type of protection "de" – Cast-iron series 1MJ6 and 1MJ7</b>																	
<b>Design for Zones 1, 2, 21 and 22 according to ATEX</b>																	
Design for Zones 1 and 21, as well as for Zone 22 for conducting dust (IP65), for mains-fed operation <sup>1)</sup>	<b>M76</b>			✓	✓	✓	✓	✓	✓	✓	✓	✓	✓	✓	✓	✓	
Design for Zones 1 and 21, as well as for Zone 22 for conducting dust (IP65), for converter-fed operation, derating <sup>1)</sup>	<b>M77</b>			✓	✓	✓	✓	✓	✓	✓	✓	✓	✓	✓	✓	✓	
<b>Motor protection</b>																	
Motor protection with PTC thermistors with 3 embedded temperature sensors for tripping <sup>2) 3)</sup>	<b>A11</b>			✓	✓	✓	✓	✓	✓	✓	✓	✓	✓	✓	✓	✓	
Motor protection with PTC thermistors with 6 embedded temperature sensors for alarm and tripping <sup>2) 3) 4)</sup>	<b>A12</b>			✓	✓	✓	✓	✓	✓	✓	✓	✓	✓	✓	✓	✓	
Motor protection with PTC thermistors for converter-fed operation with 4 embedded temperature sensors for tripping <sup>2) 3)</sup>	<b>A15</b>			✓	✓	✓	✓	✓	✓	✓	✓	✓	✓	✓	✓	✓	
Motor protection with PTC thermistors for converter-fed operation with 8 embedded temperature sensors for alarm and tripping <sup>2) 3) 4)</sup>	<b>A16</b>			✓	✓	✓	✓	✓	✓	✓	✓	✓	✓	✓	✓	✓	
Installation of 2 PT 100 screw-in resistance thermometers (basic circuit) for rolling-contact bearings <sup>2)</sup>	<b>A72</b>			-	-	-	-	-	-	-	-	-	-	O. R.	O. R.	O. R.	O. R.
Installation of 2 PT100 screw-in resistance thermometers (3-wire circuit) for rolling-contact bearings <sup>2)</sup>	<b>A78</b>			-	-	-	-	-	-	-	-	-	-	O. R.	O. R.	O. R.	O. R.
<b>Motor connection and connection box</b>																	
Connection box on RHS	<b>K09</b>			-	-	✓	✓	✓	✓	✓	✓	✓	✓	✓	✓	✓	✓
Connection box on LHS	<b>K10</b>			-	-	✓	✓	✓	✓	✓	✓	✓	✓	✓	✓	✓	✓
Connection box in cast-iron version	<b>K15</b>			✓	✓	✓	✓	✓	✓	✓	✓ <sup>5)</sup>	✓	✓	✓	□	□	□
Explosion-proof connection box, Ex d IIC type of protection <sup>6)</sup>	<b>K53</b>			✓	✓	✓	✓	✓	✓	✓	✓	✓	✓	✓	✓	✓	✓
Rotation of the connection box through 90°, entry from DE	<b>K83</b>			✓	✓	✓	✓	✓	✓	✓	✓	✓	✓	✓	✓	✓	✓
Rotation of the connection box through 90°, entry from NDE	<b>K84</b>			✓	✓	✓	✓	✓	✓	✓	✓	✓	✓	✓	✓	✓	✓
Rotation of connection box through 180°	<b>K85</b>			○	○	○	○	○	○	○	○	○	○	○	○	○	○
Auxiliary connection box 1XB3020 <sup>7)</sup>	<b>L97</b>			-	-	-	-	-	-	-	-	-	-	✓	✓	✓	✓
Saddle terminal for connection without cable lug, accessories pack (3 items of high saddle terminals)	<b>M47</b>			-	-	-	-	-	-	-	-	-	-	-	✓	✓	✓

For legend and footnotes, see Page 4/103.



# IEC Squirrel-Cage Motors

## Explosion-proof motors

### Special versions

Special versions	Additional identification code <b>-Z</b> with order code and plain text if required	Motor type frame size														
		56	63	71	80	90	100	112	132	160	180	200	225	250	280	315
<b>Self-ventilated motors in Zone 1 with type of protection "de" – Cast-iron series 1MJ6 and 1MJ7</b>																
			<b>1MJ6 (cast-iron)</b>							<b>1MJ7 (cast-iron)</b>						
<b>Windings and insulation</b>																
Increased air humidity/temperature with 30 to 60 g water per m <sup>3</sup> of air	<b>C19</b>		✓	✓	✓	✓	✓	✓	✓	✓	✓	✓	✓	✓	✓	✓
Temperature class 155 (F), used acc. to 130 (B), coolant temperature 45 °C, derating approx. 4 % <sup>8)</sup>	<b>C22</b>		✓	✓	✓	✓	✓	✓	✓	✓	✓	✓	✓	✓	✓	✓
Temperature class 155 (F), used acc. to 130 (B), coolant temperature 50 °C, derating approx. 8 % <sup>8)</sup>	<b>C23</b>		✓	✓	✓	✓	✓	✓	✓	✓	✓	✓	✓	✓	✓	✓
Temperature class 155 (F), used acc. to 130 (B), coolant temperature 55 °C, derating approx. 13 % <sup>8)</sup>	<b>C24</b>		✓	✓	✓	✓	✓	✓	✓	✓	✓	✓	✓	✓	✓	✓
Temperature class 155 (F), used acc. to 130 (B), coolant temperature 60 °C, derating approx. 18 %	<b>C25</b>		✓	✓	✓	✓	✓	✓	✓	✓	✓	✓	✓	✓	✓	✓
Increased air humidity/temperature with 60 to 100 g water per m <sup>3</sup> of air	<b>C26</b>		✓	✓	✓	✓	✓	✓	✓	✓	✓	✓	✓	✓	✓	✓
Temperature class 155 (F), used acc. to 130 (B), with a higher coolant temperature and/or site altitude	<b>Y50 •</b> and specified output, CT... °C or SA .... m above sea level		✓	✓	✓	✓	✓	✓	✓	✓	✓	✓	✓	✓	✓	✓
<b>Colors and paint finish</b>																
Standard finish in RAL 7030 stone gray			–	–	–	–	–	–	–	–	–	–	–	–	–	–
Standard finish in other standard RAL colors: RAL 1002, 1013, 1015, 1019, 2003, 2004, 3000, 3007, 5007, 5009, 5010, 5012, 5015, 5017, 5018, 5019, 6011, 6019, 6021, 7000, 7001, 7004, 7011, 7016, 7022, 7031, 7032, 7033, 7035, 9001, 9002, 9005 Page 0/18	<b>Y53 •</b> and standard finish RAL ....		–	–	–	–	–	–	–	–	–	–	–	–	–	–
Special finish in RAL 7030 stone gray <sup>9)</sup>	<b>K26</b>		□	□	□	□	□	□	□	□	□	□	□	□	□	□
Special finish in other standard RAL colors: RAL 1002, 1013, 1015, 1019, 2003, 2004, 3000, 3007, 5007, 5009, 5010, 5012, 5015, 5017, 5018, 5019, 6011, 6019, 6021, 7000, 7001, 7004, 7011, 7016, 7022, 7031, 7032, 7033, 7035, 9001, 9002, 9005 Page 0/18	<b>Y54 •</b> and special finish RAL ....		✓	✓	✓	✓	✓	✓	✓	✓	✓	✓	✓	✓	✓	✓
Special finish in special RAL colors: For RAL colors, see "Special finish in special RAL colors" Page 0/19	<b>Y51 •</b> and special finish RAL ....		✓	✓	✓	✓	✓	✓	✓	✓	✓	✓	✓	✓	✓	✓
Offshore special finish	<b>M91</b>		O. R.	O. R.	O. R.	O. R.	O. R.	O. R.	O. R.	O. R.	O. R.	O. R.	O. R.	O. R.	O. R.	O. R.
Sea air resistant special finish	<b>M94</b>		O. R.	O. R.	O. R.	O. R.	O. R.	O. R.	O. R.	O. R.	O. R.	O. R.	O. R.	O. R.	O. R.	O. R.
Unpainted (only cast iron parts primed)	<b>K23</b>		○	○	○	○	○	○	○	○	○	○	○	○	○	○
Unpainted, only primed	<b>K24</b>		✓	✓	✓	✓	✓	✓	✓	✓	✓	✓	✓	✓	✓	✓
<b>Special technology</b>																
Mounting of the explosion-proof rotary pulse encoder for use on Ex d/de motors in Zone 1 <sup>10)</sup>	<b>H87</b>		–	–	✓	✓	✓	✓	✓	✓	✓	✓	✓	✓	✓	✓
Mounting of the explosion-proof Ex de separately driven fan for use in Zone 1 <sup>11)</sup>	<b>M98</b>		–	–	–	–	–	–	–	–	–	–	–	–	–	–

# IEC Squirrel-Cage Motors

## Explosion-proof motors

### Special versions

Special versions	Additional identification code -Z with order code and plain text if required	Motor type frame size													
		56	63	71	80	90	100	112	132	160	180	200	225	250	280
<b>Self-ventilated motors in Zone 1 with type of protection "de" – Cast-iron series 1MJ6 and 1MJ7</b>															
		<b>1MJ6 (cast-iron)</b>							<b>1MJ7 (cast-iron)</b>						
<b>Mechanical design and degrees of protection</b>															
Drive-end seal for flange-mounting motors with an oil-tightness of up to 0.1 bar Not possible for type of construction IM V3; with frame size 180 M and above, only possible for 4-pole to 8-pole motors	<b>K17</b>	✓	✓	✓	✓	✓	✓	✓	✓	✓	✓	✓	✓	✓	✓
Low-noise version for 2-pole motors with clockwise direction of rotation <sup>12)</sup>	<b>K37</b>	-	-	-	-	-	✓	✓	✓	✓	✓	✓	✓	✓	✓
Low-noise version for 2-pole motors with counter-clockwise direction of rotation <sup>12)</sup>	<b>K38</b>	-	-	-	-	-	✓	✓	✓	✓	✓	✓	✓	✓	✓
IP65 degree of protection <sup>13)</sup>	<b>K50</b>	✓	✓	✓	✓	✓	✓	✓	✓	✓	✓	✓	✓	✓	✓
IP56 degree of protection (non-heavy-sea)	<b>K52</b>	✓	✓	✓	✓	✓	✓	✓	✓	✓	✓	✓	✓	✓	✓
Vibration-proof version	<b>L03</b>	✓	✓	✓	✓	✓	✓	✓	✓	-	-	-	-	-	-
Mechanical protection for encoder <sup>15)</sup>	<b>M68</b>	-	-	-	-	-	-	-	-	✓	✓	✓	✓	✓	✓
<b>Designs in accordance with standards and specifications</b>															
CCC China Compulsory Certification <sup>16)</sup>	<b>D01</b>	✓	✓	✓	-	-	-	-	-	-	-	-	-	-	-
VIK version	<b>K30</b>	✓	✓	✓	✓	✓	✓	✓	✓	✓	✓	✓	✓	✓	✓
Ex certification for China	<b>D32</b>	✓	✓	✓	✓	✓	✓	✓	✓	✓	✓	✓	✓	✓	✓
<b>Bearings and lubrication</b>															
Measuring nipple for SPM shock pulse measurement for bearing inspection	<b>G50</b>	-	-	-	-	-	-	-	✓	✓	✓	✓	✓	✓	✓
Bearing design for increased cantilever forces <sup>17)</sup>	<b>K20</b>	-	-	-	-	-	-	-	✓	✓	✓	✓	-	-	-
Regreasing device	<b>K40</b>	-	-	-	-	-	-	-	✓	✓	✓	✓	□	□	□
Insulated bearing cartridge	<b>L27</b>	-	-	-	-	-	-	-	-	-	-	✓	✓	✓	✓
<b>Balance and vibration quantity</b>															
Vibration quantity A		□	□	□	□	□	□	□	□	□	□	□	□	□	□
Vibration quantity B	<b>K02</b>	✓	✓	✓	✓	✓	✓	✓	✓	✓	✓	✓	✓	✓	✓
Full key balancing	<b>L68</b>	✓	✓	✓	✓	✓	✓	✓	✓	✓	✓	✓	✓	✓	✓
Balancing without key	<b>M37</b>	✓	✓	✓	✓	✓	✓	✓	✓	✓	✓	✓	✓	✓	✓
<b>Shaft and rotor</b>															
Concentricity of shaft extension, coaxiality and linear movement in accordance with DIN 42955 Tolerance R for flange-mounting motors <sup>18)</sup>	<b>K04</b>	-	-	-	-	-	-	-	✓	✓	✓	✓	✓	✓	✓
Second standard shaft extension <sup>19)</sup>	<b>K16</b>	✓	✓	✓	✓	✓	✓	✓	✓	✓	✓	✓	✓	✓	✓
Concentricity of shaft extension in accordance with DIN 42955 Tolerance R	<b>L39</b>	-	-	-	-	-	-	-	✓	✓	✓	✓	✓	✓	✓
Non-standard cylindrical shaft extension <sup>20)</sup>	<b>Y55 • and identification code</b>	-	-	-	-	-	-	-	-	-	-	O. R.	O. R.	O. R.	O. R.
<b>Heating and ventilation</b>															
Metal external fan	<b>K35</b>	-	-	-	✓	✓	✓	✓	✓	✓	✓	✓	✓	✓	✓
Anti-condensation heaters for 230 V <sup>21)22)</sup>	<b>K45</b>	✓	✓	✓	✓	✓	✓	✓	✓	✓	✓	✓	✓	✓	✓
Anti-condensation heaters for 115 V <sup>21)22)</sup>	<b>K46</b>	✓	✓	✓	✓	✓	✓	✓	✓	✓	✓	✓	✓	✓	✓
Separately driven fan with non-standard voltage and/or frequency	<b>Y81 • and identification code</b>	-	-	-	-	-	-	-	-	-	-	✓	✓	✓	✓

For legend and footnotes, see Page 4/103.

# IEC Squirrel-Cage Motors

## Explosion-proof motors

### Special versions

Special versions	Additional identification code <b>-Z</b> with order code and plain text if required	Motor type frame size														
		56	63	71	80	90	100	112	132	160	180	200	225	250	280	315
<b>Self-ventilated motors in Zone 1 with type of protection "de" – Cast-iron series 1MJ6 and 1MJ7</b>																
		<b>1MJ6 (cast-iron)</b>							<b>1MJ7 (cast-iron)</b>							
<b>Rating plate and extra rating plates</b>																
Second lubricating plate, supplied loose	<b>B06</b>	–	–	–	–	–	–	–	–	–	–	–	–	–	–	–
Second rating plate, loose	<b>K31</b>	✓	✓	✓	✓	✓	✓	✓	✓	✓	✓	✓	✓	✓	✓	✓
Extra rating plate or rating plate with deviating rating plate data	<b>Y80 •</b> and identification code	✓	✓	✓	✓	✓	✓	✓	✓	✓	✓	✓	✓	✓	✓	✓
Extra rating plate with identification code	<b>Y82 •</b> and identification code	✓	✓	✓	✓	✓	✓	✓	✓	✓	✓	✓	✓	✓	✓	✓
Additional information on rating plate and on package label (maximum of 20 characters)	<b>Y84 •</b> and identification code	✓	✓	✓	✓	✓	✓	✓	✓	✓	✓	✓	✓	✓	✓	✓
<b>Packaging, safety notes, documentation and test certificates</b>																
Acceptance test certificate 3.1 according to EN 10204	<b>B02</b>	✓	✓	✓	✓	✓	✓	✓	✓	✓	✓	✓	✓	✓	✓	✓
Operating instructions German/English enclosed in print	<b>B23</b>	□	□	□	□	□	□	□	□	□	□	□	□	□	□	□
Wire-lattice pallet	<b>L99</b>	○	○	○	○	○	○	○	○	○	○	○	○	○	○	○

- Standard version
- Without additional charge
- This order code only determines the price of the version – Additional plain text is required.
- R. Possible on request
- ✓ With additional charge
- Not possible

- 1) In combination with order codes **K30** and **M98** please inquire. Not possible in combination with order codes **D32**, **K50** and **K52**.
- 2) Evaluation with appropriate 3RN1 tripping unit (see Catalog LV 1) is recommended. When used in hazardous areas, a certified tripping unit is required.
- 3) For 1MJ6 motors, for a version with PTC thermistors, an anti-condensation heater (order code **K45**, **K46**) up to frame size 160 L is not possible.
- 4) For 1MJ6 motors frame sizes 180 to 200 and 1MJ7 motors, for a version with PTC thermistors, an anti-condensation heater (order code **K45**, **K46**) is not possible. Exception: 1MJ7 frame size 315.
- 5) For 1MJ6 motors frame size 160 L standard version.
- 6) Drilled holes for the cable glands are sealed with Exd plugs for 1MJ motors as standard. On request, the Exd cable entries can be supplied for 1MJ7 motors. When ordering, the number of cables and outer diameters must be specified so that the appropriate cable glands can be supplied.
- 7) Not possible in combination with order code **K53**, since the auxiliary connection box has been approved only for Ex de.
- 8) Derating does not apply in combination with order codes **L2A**, **L2C**, **L2Q**, **L2R**, **L2S**, **L2T**, **L2U** and **L2V**.
- 9) For frame sizes 71 to 200, do not specify an order code. Order code is only necessary for frame sizes 225 to 315.
- 10) In combination with order codes **C19**, **C26**, **L27** and **M98** please inquire. Not possible in combination with order codes **C22** to **C25** (frame sizes 90 to 160), **D19**, **K16**, **K50**, **M77**. Furthermore a combination with protective cover is not possible. Therefore a suitable cover must be implemented by the end user in vertical mounting position to prevent small parts from falling into the fan cover (see the standard IEC/EN 60079-0).
- 11) In combination with order codes **C19**, **C22** to **C26**, **D19**, **H87**, **K50**, **K52**, **M76** and **M77** please inquire. Not possible in combination with order code **K16**.
- 12) The motors are up to 80 mm longer than normal. A second shaft extension is not possible.
- 13) Order code **K50** (protective cover IP65) can be ordered only for Zone 1. For Zone 21, IP65 degree of protection is standard. Not possible for Zone 22, because only IP55 degree of protection is required.
- 14) A combination of order code **K52** degree of protection IP56 (non-heavy-sea) with **M76** or **M77** is not permissible.
- 15) 1MJ6 motors of frame size 90 to 160 have a rugged flanged. Ex OG9 rotary pulse encoder, which offers alone a high mechanical protection. The mechanical protection for the encoder is not necessary when a rotary pulse encoder is combined with a separately driven fan because in this case the rotary pulse encoder is installed under the fan cowl.
- 16) CCC certification is required for
  - 2-pole motors ≤2.2 kW
  - 4-pole motors ≤1.1 kW
  - 6-pole motors ≤0.75 kW
  - 8-pole motors ≤0.55 kW
- 17) Bearings for increased cantilever forces at vibration quantity level B on request.
- 18) Can be combined with deep-groove bearings of series 60.., 62.. and 63... Not possible in combination with parallel roller bearings (e.g. bearings for increased cantilever forces, order code **K20**).
- 19) For 1MJ6/1MJ7 motors of frame size 180 M and above in vertical type of construction in version with second shaft extension on request. Not possible for low-noise version (2-pole). Version with protective cover not possible.
- 20) When motors which have a longer or shorter shaft extension than normal are ordered, the required position and length of the featherkey way must be specified in a sketch. It must be ensured that only featherkeys in accordance with DIN 6885, Form A are permitted to be used. The featherkey way is positioned centrally on the shaft extension. The length is defined by the manufacturer normatively. Not valid for: Conical shafts, non-standard threaded journals, non-standard shaft tolerances, friction welded journals, extremely "thin" shafts, special geometry dimensions (e.g. square journals), hollow shafts. Valid for non-standard shaft extensions DE or NDE. The featherkeys are supplied in every case. For order codes **Y55** and **K16**:
  - Dimensions D and DA ≤ internal diameter of roller bearing (see dimension tables under "Dimensions")
  - Dimensions E and EA ≤ 2 x length E (normal) of the shaft extension For an explanation of the order codes, see catalog part 0 "Introduction".
- 21) For 1MJ6 motors, version with 3, 4 PTC thermistors (order codes **A11**, **A15**) is not possible up to frame size 160 L.
- 22) Not possible for version with 6, 8 PTC thermistors (order codes **A12**, **A16**). Exception: 1MJ7 frame size 315.

# IEC Squirrel-Cage Motors

## Explosion-proof motors

### Special versions

Special versions	Additional identification code <b>-Z</b> with order code and plain text if required	Motor type frame size														
		56	63	71	80	90	100	112	132	160	180	200	225	250	280	315
<b>Self-ventilated motors in Zones 2, 21, 22 with type of protection "n" or protection against dust explosions – Aluminum series 1LA7 and 1LA5</b>																
		<b>1LA7 (aluminum) <sup>1)</sup></b>									<b>1LA5 (aluminum) <sup>2)</sup></b>					
<b>Design for Zones 1, 2, 21 and 22 according to ATEX <sup>3)</sup></b>																
Design for Zone 2 for mains-fed operation Ex nA II T3 to IEC/EN 60079-15 <sup>4)</sup>	<b>M72</b>	–	✓	✓	✓	✓	✓	✓	✓	✓	✓	–	–	–		
Design for Zone 2 for converter-fed operation, reduced output Ex nA II T3 to IEC/EN 60079-15 <sup>4) 5) 6)</sup>	<b>M73</b>	–	✓	✓	✓	✓	✓	✓	✓	✓	✓	–	–	–		
Design for Zones 2 and 22, for non-conducting dust (IP55), for mains-fed operation <sup>7)</sup>	<b>M74</b>	–	✓	✓	✓	✓	✓	✓	✓	✓	✓	–	–	–		
Design for Zones 2 and 22, for non-conducting dust (IP55), for converter-fed operation, derating <sup>5) 6) 7)</sup>	<b>M75</b>	–	✓	✓	✓	✓	✓	✓	✓	✓	✓	–	–	–		
Design for Zone 21, as well as Zone 22 for conducting dust (IP65) for mains-fed operation <sup>8)</sup>	<b>M34</b>	✓	✓	✓	✓	✓	✓	✓	✓	✓	✓	✓	✓	✓		
Design for Zone 21, as well as Zone 22 for conducting dust (IP65) for converter-fed operation, derating <sup>4) 6) 8)</sup>	<b>M38</b>	✓	✓	✓	✓	✓	✓	✓	✓	✓	✓	✓	✓	✓		
Design for Zone 22 for non-conducting dust (IP55) for mains-fed operation	<b>M35</b>	✓	✓	✓	✓	✓	✓	✓	✓	✓	✓	✓	✓	✓		
Design for Zone 22 for conducting dust (IP55) for converter-fed operation, derating <sup>4) 6)</sup>	<b>M39</b>	✓	✓	✓	✓	✓	✓	✓	✓	✓	✓	✓	✓	✓		
VIK design (comprises Zone 2 for mains-fed operation, without Ex nA II marking on rating plate)	<b>K30</b>	–	✓	✓	✓	✓	✓	✓	✓	✓	✓	–	–	–		
Ex nA II on VIK rating plate	<b>C27</b>	–	✓	✓	✓	✓	✓	✓	✓	✓	✓	–	–	–		
Alternative converter (SIMOVERT MASTERDRIVES, SINAMICS G110, SINAMICS S120 or ET 200S FC)	<b>Y68 •</b> and converter type ....	○	○	○	○	○	○	○	○	○	○	○	○	○		
<b>Motor protection</b>																
With PTC thermistors for alarm for converter-fed operation in Zones 2, 21, 22 <sup>9)</sup>	<b>A10</b>	✓	✓	✓	✓	✓	✓	✓	✓	✓	✓	–	–	–		
Motor protection with PTC thermistors with 3 embedded temperature sensors for tripping <sup>9)</sup>	<b>A11</b>	✓	✓	✓	✓	✓	✓	✓	✓	✓	✓	✓	✓	✓		
Motor protection with PTC thermistors with 6 embedded temperature sensors for alarm and tripping <sup>9)</sup>	<b>A12</b>	✓	✓	✓	✓	✓	✓	✓	✓	✓	✓	✓	✓	✓		
Motor temperature detection with embedded temperature sensor KTY 84-130 <sup>9)</sup>	<b>A23</b>	✓	✓	✓	✓	✓	✓	✓	✓	✓	✓	✓	✓	✓		
Motor temperature detection with embedded temperature sensors 2 x KTY 84-130 <sup>9)</sup>	<b>A25</b>	✓	✓	✓	✓	✓	✓	✓	✓	✓	✓	✓	✓	✓		
Installation of 3 PT 100 resistance thermometers <sup>9)</sup>	<b>A60</b>	–	–	–	–	–	✓	✓	✓	✓	✓	✓	✓	✓		

4

For legend, see Page 4/108, for footnotes, see Page 4/109.

# IEC Squirrel-Cage Motors

## Explosion-proof motors

### Special versions

Special versions	Additional identification code -Z with order code and plain text if required	Motor type frame size														
		56	63	71	80	90	100	112	132	160	180	200	225	250	280	315
<b>Self-ventilated motors in Zones 2, 21, 22 with type of protection "n" or protection against dust explosions – Aluminum series 1LA7 and 1LA5</b>																
		<b>1LA7 (aluminum) <sup>1)</sup></b>										<b>1LA5 (aluminum) <sup>2)</sup></b>				
<b>Motor connection and connection box</b>																
Connection box on RHS	<b>K09</b>	-	-	-	✓	✓	✓	✓	✓	✓	✓	✓	✓	✓	✓	✓
Connection box on LHS	<b>K10</b>	-	-	-	✓	✓	✓	✓	✓	✓	✓	✓	✓	✓	✓	✓
One cable gland, metal <sup>10)</sup>	<b>K54</b>	✓	✓	✓	✓	✓	✓	✓	✓	✓	✓	✓	✓	✓	✓	✓
Cable gland, maximum configuration	<b>K55</b>	O. R.	O. R.	O. R.	O. R.	O. R.	O. R.	O. R.	O. R.	O. R.	O. R.	O. R.	O. R.	O. R.	O. R.	O. R.
Rotation of the connection box through 90°, entry from DE	<b>K83</b>	✓	✓	✓	✓	✓	✓	✓	✓	✓	✓	✓	✓	✓	✓	✓
Rotation of the connection box through 90°, entry from NDE	<b>K84</b>	✓	✓	✓	✓	✓	✓	✓	✓	✓	✓	✓	✓	✓	✓	✓
Rotation of connection box through 180°	<b>K85</b>	✓	✓	✓	✓	✓	○	○	○	○	✓	✓	✓	✓	✓	✓
Next larger connection box	<b>L00</b>	-	-	-	-	-	-	-	-	-	✓	✓	✓	✓	✓	✓
External earthing	<b>L13</b>	□	□	□	□	□	□	□	□	□	□	□	□	□	□	□
<b>Windings and insulation</b>																
Increased air humidity/temperature with 30 to 60 g water per m <sup>3</sup> of air	<b>C19</b>	-	✓	✓	✓	✓	✓	✓	✓	✓	✓	✓	✓	✓	✓	✓
Temperature class 155 (F), used acc. to 130 (B), coolant temperature 45 °C, derating approx. 4 % <sup>11)</sup>	<b>C22</b>	✓	✓	✓	✓	✓	✓	✓	✓	✓	✓	✓	✓	✓	✓	✓
Temperature class 155 (F), used acc. to 130 (B), coolant temperature 50 °C, derating approx. 8 % <sup>11)</sup>	<b>C23</b>	✓	✓	✓	✓	✓	✓	✓	✓	✓	✓	✓	✓	✓	✓	✓
Temperature class 155 (F), used acc. to 130 (B), coolant temperature 55 °C, derating approx. 13 % <sup>11)</sup>	<b>C24</b>	✓	✓	✓	✓	✓	✓	✓	✓	✓	✓	✓	✓	✓	✓	✓
Temperature class 155 (F), used acc. to 130 (B), coolant temperature 60 °C, derating approx. 18 %	<b>C25</b>	✓	✓	✓	✓	✓	✓	✓	✓	✓	✓	✓	✓	✓	✓	✓
Increased air humidity/temperature with 60 to 100 g water per m <sup>3</sup> of air	<b>C26</b>	-	✓	✓	✓	✓	✓	✓	✓	✓	✓	✓	✓	✓	✓	✓
Temperature class 155 (F), used acc. to 130 (B), with increased coolant temperature and/or site altitude	<b>Y50 • and specified output, CT ... °C or SA ... m above sea level</b>	✓	✓	✓	✓	✓	✓	✓	✓	✓	✓	✓	✓	✓	✓	✓

# IEC Squirrel-Cage Motors

## Explosion-proof motors

### Special versions

Special versions	Additional identification code -Z with order code and plain text if required	Motor type frame size															
		56	63	71	80	90	100	112	132	160	180	200	225	250	280	315	
<b>Self-ventilated motors in Zones 2, 21, 22 with type of protection "n" or protection against dust explosions – Aluminum series 1LA7 and 1LA5</b>																	
		<b>1LA7 (aluminum) <sup>1)</sup></b>									<b>1LA5 (aluminum) <sup>2)</sup></b>						
<b>Colors and paint finish</b>																	
Special finish in RAL 7030 stone gray		☐	☐	☐	☐	☐	☐	☐	☐	☐	☐	☐	☐	☐	☐	☐	
Special finish in other standard RAL colors: RAL 1002, 1013, 1015, 1019, 2003, 2004, 3000, 3007, 5007, 5009, 5010, 5012, 5015, 5017, 5018, 5019, 6011, 6019, 6021, 7000, 7001, 7004, 7011, 7016, 7022, 7031, 7032, 7033, 7035, 9001, 9002, 9005 Page 0/18	<b>Y54 •</b> and special finish RAL ....	✓	✓	✓	✓	✓	✓	✓	✓	✓	✓	✓	✓	✓	✓	✓	
Special finish in special RAL colors: For RAL colors, see "Special finish in special RAL colors" Page 0/19	<b>Y51 •</b> and special finish RAL ....	✓	✓	✓	✓	✓	✓	✓	✓	✓	✓	✓	✓	✓	✓	✓	
Sea air resistant special finish	<b>M94</b>	O. R.	O. R.	O. R.	O. R.	O. R.	O. R.	O. R.	O. R.	O. R.	O. R.	O. R.	O. R.	O. R.	O. R.	O. R.	
Unpainted (only cast iron parts primed)	<b>K23</b>	○	○	○	○	○	○	○	○	○	○	○	○	○	○	○	
Unpainted, only primed	<b>K24</b>	✓	✓	✓	✓	✓	✓	✓	✓	✓	✓	✓	✓	✓	✓	✓	
<b>Special technology</b>																	
Mounting of explosion-proof rotary pulse encoder for use in Zones 2, 21, 22 <sup>12)</sup>	<b>H86</b>	–	–	–	–	–	✓	✓	✓	✓	✓	✓	✓	✓	✓	✓	
Mounting of explosion-proof separately driven fan II 3D for use in Zone 22 <sup>13)</sup>	<b>M97</b>	–	–	–	–	–	✓	✓	✓	✓	✓	✓	✓	✓	✓	✓	
<b>Mechanical design and degrees of protection</b>																	
Drive-end seal for flange-mounting motors with an oil-tightness of up to 0.1 bar Not possible for IM V3 type of construction	<b>K17</b>	✓	✓	✓	✓	✓	✓	✓	✓	✓	✓	✓	✓	✓	✓	✓	
With two additional eyebolts for IM V1/IM V3	<b>K32</b>	–	–	–	–	–	–	–	–	–	–	–	–	–	✓	✓	✓
Low-noise version for 2-pole motors with clockwise direction of rotation	<b>K37</b>	–	–	–	–	–	–	–	–	–	–	–	–	–	✓	✓	✓
Low-noise version for 2-pole motors with counter-clockwise direction of rotation	<b>K38</b>	–	–	–	–	–	–	–	–	–	–	–	–	–	✓	✓	✓
IP65 degree of protection <sup>14)</sup>	<b>K50</b>	✓	✓	✓	✓	✓	✓	✓	✓	✓	✓	✓	✓	✓	✓	✓	
IP56 degree of protection (non-heavy-sea) <sup>15)</sup>	<b>K52</b>	✓	✓	✓	✓	✓	✓	✓	✓	✓	✓	✓	✓	✓	✓	✓	
Vibration-proof version	<b>L03</b>	✓	✓	✓	✓	✓	✓	✓	✓	✓	✓	✓	✓	✓	✓	✓	
Condensation drainage holes <sup>16)</sup>	<b>L12</b>	✓	✓	✓	✓	✓	✓	✓	✓	✓	✓	✓	✓	✓	✓	✓	
Rust-resistant screws (externally)	<b>M27</b>	✓	✓	✓	✓	✓	✓	✓	✓	✓	✓	✓	✓	✓	✓	✓	
Mechanical protection for encoder <sup>17)</sup>	<b>M68</b>	–	–	–	✓	✓	✓	✓	✓	✓	✓	✓	✓	✓	✓	✓	

For legend, see Page 4/108, for footnotes, see Page 4/109.

# IEC Squirrel-Cage Motors

## Explosion-proof motors

### Special versions

Special versions	Additional identification code -Z with order code and plain text if required	Motor type frame size														
		56	63	71	80	90	100	112	132	160	180	200	225	250	280	315
<b>Self-ventilated motors in Zones 2, 21, 22 with type of protection "n" or protection against dust explosions – Aluminum series 1LA7 and 1LA5</b>																
		<b>1LA7 (aluminum) <sup>1)</sup></b>										<b>1LA5 (aluminum) <sup>2)</sup></b>				
<b>Coolant temperature and site altitude</b>																
Coolant temperature –40 °C to +40 °C for EX motor <sup>18)</sup>	<b>D19</b>	✓	✓	✓	✓	✓	✓	✓	✓	✓	✓	✓	✓	✓	✓	✓
<b>Designs in accordance with standards and specifications</b>																
CCC China Compulsory Certification <sup>19)</sup>	<b>D01</b>	✓	✓	✓	✓	✓	✓	✓	–	–	–	–	–	–	–	–
Electrical according to NEMA MG1-12	<b>D30</b>	✓	✓	✓	✓	✓	✓	✓	✓	✓	✓	✓	✓	✓	✓	✓
Ex-certification for China (only valid for Zone 2)	<b>D32</b>	–	✓	✓	✓	✓	✓	✓	✓	✓	–	–	–	–	–	–
<b>Bearings and lubrication</b>																
Measuring nipple for SPM shock pulse measurement for bearing inspection	<b>G50</b>	–	–	–	–	–	✓	✓	✓	✓	✓	✓	✓	✓	✓	✓
Bearing design for increased cantilever forces	<b>K20</b>	–	–	–	–	–	✓	✓	✓	✓	✓	✓	✓	✓	✓	✓
Regreasing device	<b>K40</b>	–	–	–	–	–	✓	✓	✓	✓	✓	✓	✓	✓	✓	✓
Located bearing DE	<b>K94</b>	✓	✓	✓	✓	✓	✓	✓	✓	✓	✓	✓	✓	✓	✓	✓
Located bearing NDE	<b>L04</b>	✓	✓	✓	✓	✓	✓	✓	✓	✓	□	□	□	□	□	□
<b>Balance and vibration quantity</b>																
Vibration quantity A		□	□	□	□	□	□	□	□	□	□	□	□	□	□	□
Vibration quantity B	<b>K02</b>	✓	✓	✓	✓	✓	✓	✓	✓	✓	✓	✓	✓	✓	✓	✓
Full key balancing	<b>L68</b>	✓	✓	✓	✓	✓	✓	✓	✓	✓	✓	✓	✓	✓	✓	✓
Balancing without key	<b>M37</b>	✓	✓	✓	✓	✓	✓	✓	✓	✓	✓	✓	✓	✓	✓	✓
<b>Shaft and rotor</b>																
Concentricity of shaft extension, coaxiality and linear movement in accordance with DIN 42955 Tolerance R for flange-mounting motors <sup>20)</sup>	<b>K04</b>	✓	✓	✓	✓	✓	✓	✓	✓	✓	✓	✓	✓	✓	✓	✓
Second standard shaft extension	<b>K16</b>	✓	✓	✓	✓	✓	✓	✓	✓	✓	✓	✓	✓	✓	✓	✓
Shaft extension with standard dimensions without featherkey way	<b>K42</b>	✓	✓	✓	✓	✓	✓	✓	✓	✓	✓	✓	✓	✓	✓	✓
Concentricity of shaft extension in accordance with DIN 42955 Tolerance R	<b>L39</b>	✓	✓	✓	✓	✓	✓	✓	✓	✓	✓	✓	✓	✓	✓	✓
Standard shaft made of rust-resistant steel	<b>M65</b>	–	–	–	✓	✓	✓	✓	✓	✓	✓	✓	✓	✓	✓	✓
Non-standard cylindrical shaft extension <sup>21)</sup>	<b>Y55 • and identification code</b>	✓	✓	✓	✓	✓	✓	✓	✓	✓	✓	✓	✓	✓	✓	✓
<b>Heating and ventilation</b>																
Fan cover for textile industry	<b>H17</b>	–	–	–	✓	✓	✓	✓	✓	✓	✓	✓	✓	✓	✓	✓
Metal external fan <sup>22)</sup>	<b>K35</b>	–	✓	✓	✓	✓	✓	✓	✓	✓	✓	✓	✓	✓	✓	✓
Anti-condensation heater, Ex. 230 V	<b>M15</b>	–	–	–	O. R.	O. R.	O. R.	O. R.	O. R.	O. R.	O. R.	O. R.	O. R.	O. R.	O. R.	O. R.
Anti-condensation heater, Ex. 115 V	<b>M14</b>	–	–	–	O. R.	O. R.	O. R.	O. R.	O. R.	O. R.	O. R.	O. R.	O. R.	O. R.	O. R.	O. R.

# IEC Squirrel-Cage Motors

## Explosion-proof motors

### Special versions

Special versions	Additional identification code -Z with order code and plain text if required	Motor type frame size														
		56	63	71	80	90	100	112	132	160	180	200	225	250	280	315
<b>Self-ventilated motors in Zones 2, 21, 22 with type of protection "n" or protection against dust explosions – Aluminum series 1LA7 and 1LA5</b>																
		<b>1LA7 (aluminum) <sup>1)</sup></b>										<b>1LA5 (aluminum) <sup>2)</sup></b>				
<b>Rating plate and extra rating plates</b>																
Second lubricating plate, supplied loose	<b>B06</b>	–	–	–	–	–	✓	✓	✓	✓	✓	✓	✓	✓	✓	✓
Second rating plate, loose	<b>K31</b>	✓	✓	✓	✓	✓	✓	✓	✓	✓	✓	✓	✓	✓	✓	✓
Extra rating plate or rating plate with deviating rating plate data	<b>Y80 •</b> and identification code	✓	✓	✓	✓	✓	✓	✓	✓	✓	✓	✓	✓	✓	✓	✓
Extra rating plate with identification code	<b>Y82 •</b> and identification code	✓	✓	✓	✓	✓	✓	✓	✓	✓	✓	✓	✓	✓	✓	✓
Additional information on rating plate and on package label (maximum of 20 characters)	<b>Y84 •</b> and identification code	✓	✓	✓	✓	✓	✓	✓	✓	✓	✓	✓	✓	✓	✓	✓
<b>Packaging, safety notes, documentation and test certificates</b>																
Acceptance test certificate 3.1 according to EN 10204	<b>B02</b>	✓	✓	✓	✓	✓	✓	✓	✓	✓	✓	✓	✓	✓	✓	✓
Operating instructions German/English enclosed in print	<b>B23</b>	□	□	□	□	□	□	□	□	□	□	□	□	□	□	□
Type test with heat run for vertical motors, with acceptance	<b>F83</b>	✓	✓	✓	✓	✓	✓	✓	✓	✓	✓	✓	✓	✓	✓	✓
Wire-lattice pallet	<b>L99</b>	○	○	○	○	○	○	○	○	○	○	○	○	–	–	–
Connected in star for dispatch	<b>M32</b>	✓	✓	✓	✓	✓	✓	✓	✓	✓	✓	✓	✓	✓	✓	✓
Connected in delta for dispatch	<b>M33</b>	✓	✓	✓	✓	✓	✓	✓	✓	✓	✓	✓	✓	✓	✓	✓

- Standard version
- Without additional charge
- This order code only determines the price of the version – Additional plain text is required.
- , R. Possible on request
- ✓ With additional charge
- Not possible



- 1) Zone 2 for motor series 1LA7 only frame size 63 and above.
- 2) Zone 2 is not possible for motor series 1LA5. For Zone 2, instead of 1LA5 motors, 1LG4 motors are used.
- 3) Anti-condensation heater up to frame size 71 M not possible.
- 4) These motors do not have a rated voltage range stamped on the rating plate.
- 5) According to the standard, the motor and converter must be tested as a unit. A "Manufacturer test certificate" is available for a defined spectrum of Siemens motors (frame sizes 63 M to 315 L)/converter. Please inquire in the case of a non-Siemens converter (additional charge).
- 6) With this option, PTC thermistors for temperature class 130 (B) are included. For compliance with temperature class 130 (B), derating is necessary in the case of converter-fed operation in Zones 2, 21 and 22. The operating data for the MICROMASTER converter series from Siemens are specified on the rating plate as standard. Derating information is available on request. For converter-fed operation only voltage codes/order codes with only one voltage are permitted, see also Page 4/82.
- 7) In combination with order codes **D19**, **K30** and **M97** please inquire. Not possible in combination with order codes **D32**, **K50** and **K52**.
- 8) Zone 21 takes into account conducting and non-conducting dust.
- 9) Evaluation with appropriate tripping unit (see Catalog LV 1) is recommended. When used in hazardous areas, a certified tripping unit is required. KTY 84-130 and PT 100 are not permitted as sole protection. Full motor protection for mains-fed operation implemented only with PTC thermistors, please inquire.
- 10) For 1LA7 and 1LA5 motors additional charge only applies to Zone 22. Designs for Zones 2 and 21 already have a certified metal cable gland in the standard version.
- 11) Derating does not apply in combination with order codes **L2A**, **L2C**, **L2Q**, **L2R**, **L2S**, **L2T**, **L2U** and **L2V**.
- 12) In combination with order codes **C19**, **C26**, **L27** and **M97** please inquire. Not possible in combination with order code **K16**. Furthermore a combination with protective cover is not possible. Therefore a suitable cover must be implemented by the end user in vertical mounting position to prevent small parts from falling into the fan cover (see the standard IEC/EN 60079-0).
- 13) In combination with order codes **C19**, **C22**, **C23**, **C24**, **C25**, **C26**, **D19**, **H86**, **K50** and **K52** please inquire. Not possible in combination with order codes **C27**, **K16**, **K30**, **M72**, **M73**, **M34**, **M38**, **M74** and **M75**.
- 14) Order code **K50** (IP65 degree of protection) can only be ordered for Zone 2. For Zone 21, IP65 degree of protection is standard. Not possible for Zone 22, because only IP55 degree of protection is required.
- 15) Order code **K52** IP56 degree of protection (non-heavy-sea) is only possible for Zone 2. Not admissible for Zone 21 (IP65 degree of protection) and Zone 22 (IP55 degree of protection).
- 16) When supplied the condensation drainage holes are sealed at the drive end DE and non-drive end NDE for IP55, IP56 and IP65 degrees of protection. If condensation drainage holes are required in motors of the IM B6, IM B7 or IM B8 type of construction (feet located on side or top), it is necessary to relocate the bearing plates at the drive end (DE) and non-drive end (NDE) so that the condensation drainage holes situated between the feet on delivery are underneath.
- 17) Not necessary when a rotary pulse encoder is combined with a separately driven fan, because in this case the rotary pulse encoder is installed under the fan cover.
- 18) Not possible in combination with order code **L03**. The mechanical limit speed of 1LA5 2-pole motors in the design for Zones 21/22 from frame size 180 has been reduced compared to the values in catalog part 5 "Motors operating with frequency converters" of the catalog:

Frame size	2 pole $n_{max}$ in rpm	$f_{max}$ in Hz
180	3300	55
200	3100	51
225	3000	50

This is particularly important to be observed for converter-fed operation and operation on 60 Hz line supplies. Option: 1LG4 motors in the design for Zones 21/22.
- 19) CCC certification is required for
  - 2-pole motors:  $\leq 2.2$  kW
  - 4-pole motors:  $\leq 1.1$  kW
  - 6-pole motors:  $\leq 0.75$  kW
  - 8-pole motors:  $\leq 0.55$  kW
- 20) Can be combined with deep-groove bearings of series 60... 62... and 63... Not possible with parallel roller bearings (e.g. bearings for increased cantilever forces, order code **K20**).
- 21) When motors which have a longer or shorter shaft extension than normal are ordered, the required position and length of the featherkey way must be specified in a sketch. It must be ensured that only featherkeys in accordance with DIN 6885, Form A are permitted to be used. The featherkey way is positioned centrally on the shaft extension. The length is defined by the manufacturer normatively. Not valid for: Conical shafts, non-standard threaded journals, non-standard shaft tolerances, friction welded journals, extremely "thin" shafts, special geometry dimensions (e.g. square journals), hollow shafts. Valid for non-standard shaft extensions DE or NDE. The featherkeys are supplied in every case. For order codes **Y55** and **K16**:
  - Dimensions D and DA  $\leq$  internal diameter of roller bearing (see dimension tables under "Dimensions")
  - Dimensions E and EA  $\leq 2 \times$  length E (normal) of the shaft extension
For an explanation of the order codes, see catalog part 0 "Introduction".
- 22) For 1LA5/6/7/9 motors and 1LG with metal external fan, converter-fed operation is permitted. The metal external fan is standard for these motors in the version for Zone 21/22. The metal external fan is not possible in combination with the low-noise version – order code **K37** or **K38**.

# IEC Squirrel-Cage Motors

## Explosion-proof motors

### Special versions

Special versions	Additional identification code <b>-Z</b> with order code and plain text if required	Motor type frame size														
		56	63	71	80	90	100	112	132	160	180	200	225	250	280	315
<b>Self-ventilated motors in Zones 2, 21 and 22 with type of protection “n” or protection against dust explosions – Aluminum series 1LA9</b>																
<b>1LA9 (aluminum)</b>																
<b>Design for Zones 1, 2, 21 and 22 according to ATEX <sup>1)</sup></b>																
Design for Zone 2 for mains-fed operation Ex nA II T3 to IEC/EN 60079-15 <sup>2)</sup>	<b>M72</b>	–	✓	✓	✓	✓	✓	✓	✓	✓	✓	–	–			
Design for Zone 2 for converter-fed operation, reduced output Ex nA II T3 to IEC/EN 60079-15 <sup>2)3)4)</sup>	<b>M73</b>	–	✓	✓	✓	✓	✓	✓	✓	✓	✓	–	–			
Design for Zones 2 and 22, for non-conducting dust (IP55), for mains-fed operation <sup>5)</sup>	<b>M74</b>	–	✓	✓	✓	✓	✓	✓	✓	✓	✓	–	–			
Design for Zones 2 and 22, for non-conducting dust (IP55), for converter-fed operation, derating <sup>3)4)5)</sup>	<b>M75</b>	–	✓	✓	✓	✓	✓	✓	✓	✓	✓	–	–			
Design for Zone 21, as well as Zone 22 for conducting dust (IP65) for mains-fed operation <sup>6)</sup>	<b>M34</b>	✓	✓	✓	✓	✓	✓	✓	✓	✓	✓	✓	✓			
Design for Zone 21, as well as Zone 22 for conducting dust (IP65) for converter-fed operation, derating <sup>2)4)6)</sup>	<b>M38</b>	✓	✓	✓	✓	✓	✓	✓	✓	✓	✓	✓	✓			
Design for Zone 22 for non-conducting dust (IP55) for mains-fed operation	<b>M35</b>	✓	✓	✓	✓	✓	✓	✓	✓	✓	✓	✓	✓			
Design for Zone 22 for non-conducting dust (IP55) for converter-fed operation, derating <sup>2)4)</sup>	<b>M39</b>	✓	✓	✓	✓	✓	✓	✓	✓	✓	✓	✓	✓			
VIK design (comprises Zone 2 for mains-fed operation, without Ex nA II marking on rating plate)	<b>K30</b>	–	✓	✓	✓	✓	✓	✓	✓	✓	✓	–	–			
Ex nA II on VIK rating plate	<b>C27</b>	–	✓	✓	✓	✓	✓	✓	✓	✓	✓	–	–			
Alternative converter (SIMOVERT MASTERDRIVES, SINAMICS G110, SINAMICS S120 or ET 200S FC)	<b>Y68 •</b> and converter type ....	○	○	○	○	○	○	○	○	○	○	○	○			
<b>Motor protection</b>																
With PTC thermistors for alarm for converter-fed operation in Zones 2, 21, 22 <sup>7)</sup>	<b>A10</b>	✓	✓	✓	✓	✓	✓	✓	✓	✓	✓	✓	✓			
Motor protection with PTC thermistors with 3 embedded temperature sensors for tripping <sup>7)</sup>	<b>A11</b>	✓	✓	✓	✓	✓	✓	✓	✓	✓	✓	✓	✓			
Motor protection with PTC thermistors with 6 embedded temperature sensors for alarm and tripping <sup>7)</sup>	<b>A12</b>	✓	✓	✓	✓	✓	✓	✓	✓	✓	✓	✓	✓			
Motor temperature detection with embedded temperature sensor KTY 84-130 <sup>7)</sup>	<b>A23</b>	✓	✓	✓	✓	✓	✓	✓	✓	✓	✓	✓	✓			
Motor temperature detection with embedded temperature sensors 2 x KTY 84-130 <sup>7)</sup>	<b>A25</b>	✓	✓	✓	✓	✓	✓	✓	✓	✓	✓	✓	✓			
Installation of 3 PT 100 resistance thermometers <sup>7)</sup>	<b>A60</b>	–	–	–	–	–	✓	✓	✓	✓	✓	✓	✓			

For legend, see Page 4/113, for footnotes, see Page 4/114.

# IEC Squirrel-Cage Motors

## Explosion-proof motors

### Special versions

Special versions	Additional identification code <b>-Z</b> with order code and plain text if required	Motor type frame size														
		56	63	71	80	90	100	112	132	160	180	200	225	250	280	315
<b>Self-ventilated motors in Zones 2, 21 and 22 with type of protection "n" or protection against dust explosions – Aluminum series 1LA9</b>																
<b>1LA9 (aluminum)</b>																
<b>Motor connection and connection box</b>																
Connection box on RHS	<b>K09</b>	–	–	–	✓	✓	✓	✓	✓	✓	✓	✓	✓	✓	✓	✓
Connection box on LHS	<b>K10</b>	–	–	–	✓	✓	✓	✓	✓	✓	✓	✓	✓	✓	✓	✓
One cable gland, metal <sup>8)</sup>	<b>K54</b>	–	–	–	–	–	✓	✓	✓	✓	–	–	–	–	–	–
Cable gland, maximum configuration	<b>K55</b>	O. R.	O. R.	O. R.	O. R.	O. R.	O. R.	O. R.	O. R.	O. R.	O. R.	O. R.	O. R.	O. R.	O. R.	O. R.
Rotation of the connection box through 90°, entry from DE	<b>K83</b>	✓	✓	✓	✓	✓	✓	✓	✓	✓	✓	✓	✓	✓	✓	✓
Rotation of the connection box through 90°, entry from NDE	<b>K84</b>	✓	✓	✓	✓	✓	✓	✓	✓	✓	✓	✓	✓	✓	✓	✓
Rotation of connection box through 180°	<b>K85</b>	✓	✓	✓	✓	✓	○	○	○	○	✓	✓	✓	✓	✓	✓
Next larger connection box	<b>L00</b>	–	–	–	–	–	–	–	–	–	–	–	–	–	–	–
External earthing	<b>L13</b>	□	□	□	□	□	□	□	□	□	□	□	□	□	□	□
<b>Windings and insulation</b>																
Increased air humidity/temperature with 30 to 60 g water per m <sup>3</sup> of air	<b>C19</b>	–	✓	✓	✓	✓	✓	✓	✓	✓	✓	✓	✓	✓	✓	✓
Temperature class 155 (F), used acc. to 130 (B), coolant temperature 45 °C, derating approx. 4 % <sup>9)</sup>	<b>C22</b>	✓	✓	✓	✓	✓	✓	✓	✓	✓	✓	✓	✓	✓	✓	✓
Temperature class 155 (F), used acc. to 130 (B), coolant temperature 50 °C, derating approx. 8 % <sup>9)</sup>	<b>C23</b>	✓	✓	✓	✓	✓	✓	✓	✓	✓	✓	✓	✓	✓	✓	✓
Temperature class 155 (F), used acc. to 130 (B), coolant temperature 55 °C, derating approx. 13 % <sup>9)</sup>	<b>C24</b>	✓	✓	✓	✓	✓	✓	✓	✓	✓	✓	✓	✓	✓	✓	✓
Temperature class 155 (F), used acc. to 130 (B), coolant temperature 60 °C, derating approx. 18 %	<b>C25</b>	✓	✓	✓	✓	✓	✓	✓	✓	✓	✓	✓	✓	✓	✓	✓
Increased air humidity/temperature with 60 to 100 g water per m <sup>3</sup> of air	<b>C26</b>	–	✓	✓	✓	✓	✓	✓	✓	✓	✓	✓	✓	✓	✓	✓
Temperature class 155 (F), used acc. to 130 (B), with a higher coolant temperature and/or site altitude	<b>Y50 •</b> and specified output, CT .. °C or SA .... m above sea level	✓	✓	✓	✓	✓	✓	✓	✓	✓	✓	✓	✓	✓	✓	✓
<b>Colors and paint finish</b>																
Special finish in RAL 7030 stone gray		□	□	□	□	□	□	□	□	□	□	□	□	□	□	□
Special finish in other standard RAL colors: RAL 1002, 1013, 1015, 1019, 2003, 2004, 3000, 3007, 5007, 5009, 5010, 5012, 5015, 5017, 5018, 5019, 6011, 6019, 6021, 7000, 7001, 7004, 7011, 7016, 7022, 7031, 7033, 7035, 9001, 9002, 9005 Page 0/18	<b>Y54 •</b> and special finish RAL ....	✓	✓	✓	✓	✓	✓	✓	✓	✓	✓	✓	✓	✓	✓	✓
Special finish in special RAL colors: For RAL colors, see "Special finish in special RAL colors" Page 0/19	<b>Y51 •</b> and special finish RAL ....	✓	✓	✓	✓	✓	✓	✓	✓	✓	✓	✓	✓	✓	✓	✓
Sea air resistant special finish	<b>M94</b>	O. R.	O. R.	O. R.	O. R.	O. R.	O. R.	O. R.	O. R.	O. R.	O. R.	O. R.	O. R.	O. R.	O. R.	O. R.
Unpainted (only cast iron parts primed)	<b>K23</b>	○	○	○	○	○	○	○	○	○	○	○	○	○	○	○
Unpainted, only primed	<b>K24</b>	✓	✓	✓	✓	✓	✓	✓	✓	✓	✓	✓	✓	✓	✓	✓

For legend, see Page 4/113, for footnotes, see Page 4/114.

# IEC Squirrel-Cage Motors

## Explosion-proof motors

### Special versions

Special versions	Additional identification code <b>-Z</b> with order code and plain text if required	Motor type frame size														
		56	63	71	80	90	100	112	132	160	180	200	225	250	280	315
<b>Self-ventilated motors in Zones 2, 21 and 22 with type of protection "n" or protection against dust explosions – Aluminum series 1LA9</b>																
<b>1LA9 (aluminum)</b>																
<b>Special technology</b>																
Mounting of explosion-proof rotary pulse encoder for use in Zones 2, 21, 22 <sup>10)</sup>	<b>H86</b>	-	-	-	-	-	✓	✓	✓	✓	✓	✓				
Mounting of explosion-proof separately driven fan II 3D for use in Zone 22 <sup>11)</sup>	<b>M97</b>	-	-	-	-	-	✓	✓	✓	✓	✓	✓				
<b>Mechanical design and degrees of protection</b>																
Drive-end seal for flange-mounting motors with an oil-tightness of up to 0.1 bar Not possible for IM V3 type of construction.	<b>K17</b>	✓	✓	✓	✓	✓	✓	✓	✓	✓	✓	✓	✓	✓	✓	✓
Low-noise version for 2-pole motors with clockwise direction of rotation	<b>K37</b>	-	-	-	-	-	-	-	-	-	✓	✓				
Low-noise version for 2-pole motors with counter-clockwise direction of rotation	<b>K38</b>	-	-	-	-	-	-	-	-	-	✓	✓				
IP65 degree of protection <sup>12)</sup>	<b>K50</b>	✓	✓	✓	✓	✓	✓	✓	✓	✓	✓	✓	✓	✓	✓	✓
IP56 degree of protection (non-heavy-sea) <sup>13)</sup>	<b>K52</b>	✓	✓	✓	✓	✓	✓	✓	✓	✓	✓	✓	✓	✓	✓	✓
Vibration-proof version	<b>L03</b>	✓	✓	✓	✓	✓	✓	✓	✓	✓	✓	✓	✓	✓	✓	✓
Condensation drainage holes <sup>14)</sup>	<b>L12</b>	✓	✓	✓	✓	✓	✓	✓	✓	✓	✓	✓	✓	✓	✓	✓
Rust-resistant screws (externally)	<b>M27</b>	✓	✓	✓	✓	✓	✓	✓	✓	✓	✓	✓	✓	✓	✓	✓
Mechanical protection for encoder <sup>15)</sup>	<b>M68</b>	-	-	-	-	✓	✓	✓	✓	✓	✓	✓	✓	✓	✓	✓
<b>Coolant temperature and site altitude</b>																
Coolant temperature -40 °C to +40 °C for EX motor <sup>16)</sup>	<b>D19</b>	✓	✓	✓	✓	✓	✓	✓	✓	✓	✓	✓	✓	✓	✓	✓
<b>Designs in accordance with standards and specifications</b>																
CCC China Compulsory Certification <sup>17)</sup>	<b>D01</b>	✓	✓	✓	✓	✓	-	-	-	-	-	-	-	-	-	-
Electrical according to NEMA MG1-12	<b>D30</b>	-	✓	✓	✓	✓	✓	✓	✓	✓	✓	✓	✓	✓	✓	✓
Ex-certification for China (only valid for Zone 2)	<b>D32</b>	-	✓	✓	✓	✓	✓	✓	✓	✓	✓	✓	-	-	-	-
<b>Bearings and lubrication</b>																
Measuring nipple for SPM shock pulse measurement for bearing inspection	<b>G50</b>	-	-	-	-	-	✓	✓	✓	✓	✓	✓	✓	✓	✓	✓
Bearing design for increased cantilever forces	<b>K20</b>	-	-	-	-	-	✓	✓	✓	✓	✓	✓	✓	✓	✓	✓
Regreasing device	<b>K40</b>	-	-	-	-	-	✓	✓	✓	✓	✓	✓	✓	✓	✓	✓
Located bearing DE	<b>K94</b>	✓	✓	✓	✓	✓	✓	✓	✓	✓	✓	✓	✓	✓	✓	✓
Located bearing NDE	<b>L04</b>	✓	✓	✓	✓	✓	✓	✓	✓	✓	✓	□	□	□	□	□
<b>Balance and vibration quantity</b>																
Vibration quantity A		□	□	□	□	□	□	□	□	□	□	□	□	□	□	□
Vibration quantity B	<b>K02</b>	✓	✓	✓	✓	✓	✓	✓	✓	✓	✓	✓	✓	✓	✓	✓
Full key balancing	<b>L68</b>	✓	✓	✓	✓	✓	✓	✓	✓	✓	✓	✓	✓	✓	✓	✓
Balancing without key	<b>M37</b>	✓	✓	✓	✓	✓	✓	✓	✓	✓	✓	✓	✓	✓	✓	✓

For legend, see Page 4/113, for footnotes, see Page 4/114.

# IEC Squirrel-Cage Motors

## Explosion-proof motors

### Special versions

Special versions	Additional identification code <b>-Z</b> with order code and plain text if required	Motor type frame size														
		56	63	71	80	90	100	112	132	160	180	200	225	250	280	315
<b>Self-ventilated motors in Zones 2, 21 and 22 with type of protection "n" or protection against dust explosions – Aluminum series 1LA9</b>																
<b>1LA9 (aluminum)</b>																
<b>Shaft and rotor</b>																
Concentricity of shaft extension, coaxiality and linear movement in accordance with DIN 42955 Tolerance R for flange-mounting motors <sup>18)</sup>	<b>K04</b>	✓	✓	✓	✓	✓	✓	✓	✓	✓	✓	✓	✓	✓	✓	✓
Second standard shaft extension	<b>K16</b>	✓	✓	✓	✓	✓	✓	✓	✓	✓	✓	✓	✓	✓	✓	✓
Shaft extension with standard dimensions without featherkey way	<b>K42</b>	✓	✓	✓	✓	✓	✓	✓	✓	✓	✓	✓	✓	✓	✓	✓
Concentricity of shaft extension in accordance with DIN 42955 Tolerance R	<b>L39</b>	✓	✓	✓	✓	✓	✓	✓	✓	✓	✓	✓	✓	✓	✓	✓
Non-standard cylindrical shaft extension <sup>19)</sup>	<b>Y55 •</b> and identification code	✓	✓	✓	✓	✓	✓	✓	✓	✓	✓	✓	✓	✓	✓	✓
<b>Heating and ventilation</b>																
Fan cover for textile industry	<b>H17</b>	–	–	–	–	–	–	✓	✓	–	–	–	–	–	–	–
Metal external fan <sup>20)</sup>	<b>K35</b>	–	✓	✓	✓	✓	✓	✓	✓	✓	✓	✓	✓	✓	✓	✓
Anti-condensation heater, Ex. 230 V	<b>M15</b>	–	–	–	O. R.	O. R.	O. R.	O. R.	O. R.	O. R.	O. R.	O. R.	O. R.	O. R.	O. R.	O. R.
Anti-condensation heater, Ex. 115 V	<b>M14</b>	–	–	–	O. R.	O. R.	O. R.	O. R.	O. R.	O. R.	O. R.	O. R.	O. R.	O. R.	O. R.	O. R.
<b>Rating plate and extra rating plates</b>																
Second lubricating plate, supplied loose	<b>B06</b>	–	–	–	–	–	✓	✓	✓	✓	✓	✓	✓	✓	✓	✓
Second rating plate, loose	<b>K31</b>	✓	✓	✓	✓	✓	✓	✓	✓	✓	✓	✓	✓	✓	✓	✓
Extra rating plate or rating plate with deviating rating plate data	<b>Y80 •</b> and identification code	✓	✓	✓	✓	✓	✓	✓	✓	✓	✓	✓	✓	✓	✓	✓
Extra rating plate with identification code	<b>Y82 •</b> and identification code	✓	✓	✓	✓	✓	✓	✓	✓	✓	✓	✓	✓	✓	✓	✓
Additional information on rating plate and on package label (maximum of 20 characters)	<b>Y84 •</b> and identification code	✓	✓	✓	✓	✓	✓	✓	✓	✓	✓	✓	✓	✓	✓	✓
<b>Packaging, safety notes, documentation and test certificates</b>																
Acceptance test certificate 3.1 according to EN 10204	<b>B02</b>	✓	✓	✓	✓	✓	✓	✓	✓	✓	✓	✓	✓	✓	✓	✓
Operating instructions German/English enclosed in print	<b>B23</b>	□	□	□	□	□	□	□	□	□	□	□	□	□	□	□
Type test with heat run for vertical motors, with acceptance	<b>F83</b>	✓	✓	✓	✓	✓	✓	✓	✓	✓	✓	✓	✓	✓	✓	✓
Wire-lattice pallet	<b>L99</b>	○	○	○	○	○	○	○	○	○	○	○	○	○	○	–
Connected in star for dispatch	<b>M32</b>	✓	✓	✓	✓	✓	✓	✓	✓	✓	✓	✓	✓	✓	✓	✓
Connected in delta for dispatch	<b>M33</b>	✓	✓	✓	✓	✓	✓	✓	✓	✓	✓	✓	✓	✓	✓	✓

- Standard version
- Without additional charge
- This order code only determines the price of the version – Additional plain text is required.
- O. R. Possible on request
- ✓ With additional charge
- Not possible

# IEC Squirrel-Cage Motors

## Explosion-proof motors

### Special versions

# 4

- 1) Anti-condensation heater up to frame size 71 M not possible.
- 2) These motors do not have a rated voltage range stamped on the rating plate.
- 3) According to the standard, the motor and converter must be tested as a unit. A "Manufacturer test certificate" is available for a defined spectrum of Siemens motors (frame sizes 63 M to 315 L)/converter. Please inquire in the case of a non-Siemens converter (additional charge).
- 4) With this option, PTC thermistors for temperature class 130 (B) are included. For compliance with temperature class 130 (B), derating is necessary in the case of converter-fed operation in Zones 2, 21 and 22. The operating data for the MICROMASTER converter series from Siemens are specified on the rating plate as standard. Derating information is available on request. For converter-fed operation only voltage codes/order codes with only one voltage are permitted, see also Page 4/82.
- 5) In combination with order codes **D19**, **K30** and **M97** please inquire. Not possible in combination with order codes **D32**, **K50** and **K52**.
- 6) Zone 21 takes into account conducting and non-conducting dust.
- 7) Evaluation with appropriate tripping unit (see Catalog LV 1) is recommended. When used in hazardous areas, a certified tripping unit is required. KTY 84-130 and PT 100 are not permitted as sole protection. Full motor protection for mains-fed operation implemented only with PTC thermistors, please inquire.
- 8) For 1LA9 motors additional charge only applies to Zone 22. Designs for Zones 2 and 21 already have a certified metal cable gland in the standard version.
- 9) Derating does not apply in combination with order codes **L2A**, **L2C**, **L2Q**, **L2R**, **L2S**, **L2T**, **L2U** and **L2V**.
- 10) In combination with order codes **C19**, **C26**, **L27** and **M97** please inquire. Not possible in combination with order code **K16**. Furthermore a combination with protective cover is not possible. Therefore a suitable cover must be implemented by the end user in vertical mounting position to prevent small parts from falling into the fan cover (see the standard IEC/EN 60079-0).
- 11) In combination with order codes **C19**, **C22**, **C23**, **C24**, **C25**, **C26**, **C27**, **D19**, **H86**, **K30**, **K50** and **K52** please inquire. Not possible in combination with order codes **C27**, **K16**, **K30**, **M72**, **M73**, **M34**, **M38**, **M74** and **M75**.
- 12) Order code **K50** (IP65 degree of protection) can only be ordered for Zone 2. For Zone 21, IP65 degree of protection is standard. Not possible for Zone 22, because only IP55 degree of protection is required.
- 13) Order code **K52** IP56 degree of protection (non-heavy-sea) is only possible for Zone 2. Not admissible for Zone 21 (IP65 degree of protection) and Zone 22 (IP55 degree of protection).
- 14) When supplied the condensation drainage holes are sealed at the drive end DE and non-drive end NDE for IP55, IP56 and IP65 degrees of protection. If condensation drainage holes are required in motors of the IM B6, IM B7 or IM B8 type of construction (feet located on side or top), it is necessary to relocate the bearing plates at the drive end (DE) and non-drive end (NDE) so that the condensation drainage holes situated between the feet on delivery are underneath.
- 15) Not necessary when a rotary pulse encoder is combined with a separately driven fan, because in this case the rotary pulse encoder is installed under the fan cover.
- 16) Not possible in combination with order code **L03**.  
The mechanical limit speed of 1LA9 2-pole motors in the design for Zones 21/22 from frame size 180 has been reduced compared to the values in catalog part 5 "Motors operating with frequency converters" of the catalog:
 

Frame size	2 pole $n_{max}$ in rpm	$f_{max}$ in Hz
180	3300	55
200	3100	51

This is particularly important to be observed for converter-fed operation and operation on 60 Hz line supplies. Option: 1LG6 motors in the design for Zones 21/22.
- 17) CCC certification is required for
  - 2-pole motors  $\leq 2.2$  kW
  - 4-pole motors  $\leq 1.1$  kW
  - 6-pole motors  $\leq 0.75$  kW
  - 8-pole motors  $\leq 0.55$  kW
- 18) Can be combined with deep-groove bearings of series 60... 62... and 63... Not possible with parallel roller bearings (e.g. bearings for increased cantilever forces, order code **K20**).
- 19) When motors which have a longer or shorter shaft extension are ordered, the required position and length of the featherkey way must be specified in a sketch. It must be ensured that only featherkeys in accordance with DIN 6885, Form A are permitted to be used. The featherkey way is positioned centrally on the shaft extension. The length is defined by the manufacturer normatively. Not valid for: Conical shafts, non-standard threaded journals, non-standard shaft tolerances, friction welded journals, extremely "thin" shafts, special geometry dimensions (e.g. square journals), hollow shafts. Valid for non-standard shaft extensions DE or NDE. The featherkeys are supplied in every case.  
For order codes **Y55** and **K16**:
  - Dimensions D and DA  $\leq$  internal diameter of roller bearing (see dimension tables under "Dimensions")
  - Dimensions E and EA  $\leq 2 \times$  length E (normal) of the shaft extension
 For an explanation of the order codes, see catalog part 0 "Introduction".
- 20) For 1LA5/6/7/9 motors and 1LG with metal external fan, converter-fed operation is permitted. The metal external fan is standard for these motors in the version for Zone 21/22. The metal external fan is not possible in combination with a low-noise version – order code **K37** or **K38**.

# IEC Squirrel-Cage Motors

## Explosion-proof motors

Special versions

Special versions	Additional identification code -Z with order code and plain text if required	Motor type frame size														
		56	63	71	80	90	100	112	132	160	180	200	225	250	280	315
<b>Self-ventilated motors in Zones 2, 21, 22 with type of protection "n" or protection against dust explosions – Cast-iron series 1LA6 and 1LG4</b>																
<b>Design for Zones 1, 2, 21 and 22 according to ATEX <sup>1)</sup></b>																
Design for Zone 2 for mains-fed operation Ex nA II T3 to IEC/EN 60079-15 <sup>2)</sup>	<b>M72</b>															
Design for Zone 2 for converter-fed operation, reduced output Ex nA II T3 to IEC/EN 60079-15 <sup>2) 3) 4)</sup>	<b>M73</b>															
Design for Zones 2 and 22, for non-conducting dust (IP55), for mains-fed operation <sup>5)</sup>	<b>M74</b>															
Design for Zones 2 and 22, for non-conducting dust (IP55), for converter-fed operation, derating <sup>3) 4) 5)</sup>	<b>M75</b>															
Design for Zone 21, as well as Zone 22 for conducting dust (IP65) for mains-fed operation <sup>6)</sup>	<b>M34</b>									✓	✓	✓	✓	✓	✓	✓
Design for Zone 21, as well as Zone 22 for conducting dust (IP65) for converter-fed operation, derating <sup>2) 4) 6)</sup>	<b>M38</b>									✓	✓	✓	✓	✓	✓	✓
Design for Zone 22 for non-conducting dust (IP55) for mains-fed operation	<b>M35</b>									✓	✓	✓	✓	✓	✓	✓
Design for Zone 22 for non-conducting dust (IP55) for converter-fed operation, derating <sup>2) 4)</sup>	<b>M39</b>									✓	✓	✓	✓	✓	✓	✓
VIK design (comprises Zone 2 for mains-fed operation, without Ex nA II marking on rating plate)	<b>K30</b>									✓	✓	✓	✓	✓	✓	✓
Ex nA II on VIK rating plate	<b>C27</b>									✓	✓	✓	✓	✓	✓	✓
Alternative converter (SIMOVERT MASTERDRIVES, SINAMICS G110, SINAMICS S120 or ET 200S FC)	<b>Y68 •</b> and converter type ....									○	○	○	○	○	○	○
<b>Motor protection</b>																
With PTC thermistors for alarm for converter-fed operation in Zones 2, 21, 22 <sup>7)</sup>	<b>A10</b>									✓	✓	✓	✓	✓	✓	✓
Motor protection with PTC thermistors with 3 embedded temperature sensors for tripping <sup>7)</sup>	<b>A11</b>									✓	✓	✓	✓	✓	✓	✓
Motor protection with PTC thermistors with 6 embedded temperature sensors for alarm and tripping <sup>7)</sup>	<b>A12</b>									✓	✓	✓	✓	✓	✓	✓
Motor temperature detection with embedded temperature sensor KTY 84-130 <sup>7)</sup>	<b>A23</b>									✓	✓	✓	✓	✓	✓	✓
Motor temperature detection with embedded temperature sensors 2 x KTY 84-130 <sup>7)</sup>	<b>A25</b>									✓	✓	✓	✓	✓	✓	✓
Installation of 3 PT 100 resistance thermometers <sup>7)</sup>	<b>A60</b>									✓	✓	✓	✓	✓	✓	✓
Installation of 6 PT 100 resistance thermometers in stator winding <sup>7)</sup>	<b>A61</b>									–	–	–	–	✓	✓	✓

4

# IEC Squirrel-Cage Motors

## Explosion-proof motors

### Special versions

Special versions	Additional identification code <b>-Z</b> with order code and plain text if required	Motor type frame size														
		56	63	71	80	90	100	112	132	160	180	200	225	250	280	315
<b>Self-ventilated motors in Zones 2, 21, 22 with type of protection "n" or protection against dust explosions – Cast-iron series 1LA6 and 1LG4</b>																
							<b>1LA6 (cast-iron)</b>					<b>1LG4 (cast-iron)</b>				
<b>Motor protection (continued)</b>																
Installation of 2 PT 100 screw-in resistance thermometers (basic circuit) for rolling-contact bearings <sup>7)</sup>	<b>A72</b>						–	–	–	–	✓	✓	✓	✓	✓	✓
Installation of 2 PT 100 screw-in resistance thermometers (3-wire circuit) for rolling-contact bearings <sup>7)</sup>	<b>A78</b>						–	–	–	–	✓	✓	✓	✓	✓	✓
Installation of 2 PT 100 double screw-in resistance thermometers (3-wire circuit) for rolling-contact bearings <sup>7)</sup>	<b>A80</b>						–	–	–	–	✓	✓	✓	✓	✓	✓
<b>Motor connection and connection box</b>																
Two-part plate on connection box	<b>K06</b>						–	–	–	–	–	✓	✓	✓	✓	✓
Connection box on RHS	<b>K09</b>						✓	✓	✓	✓	✓	✓	✓	✓	✓	✓
Connection box on LHS	<b>K10</b>						✓	✓	✓	✓	✓	✓	✓	✓	✓	✓
Connection box on top, feet screwed on	<b>K11</b>						–	–	–	–	✓	✓	✓	✓	✓	✓
Connection box in cast-iron version	<b>K15</b>						–	–	–	–	✓	✓	✓	□	□	□
One cable gland, metal <sup>8)</sup>	<b>K54</b>						✓	✓	✓	✓	✓	✓	✓	✓	✓	✓
Cable gland, maximum configuration <sup>8)</sup>	<b>K55</b>						O. R.	O. R.	O. R.	O. R.	O. R.	O. R.	O. R.	O. R.	O. R.	O. R.
Rotation of the connection box through 90°, entry from DE	<b>K83</b>						✓	✓	✓	✓	✓	✓	✓	✓	✓	✓
Rotation of the connection box through 90°, entry from NDE	<b>K84</b>						✓	✓	✓	✓	✓	✓	✓	✓	✓	✓
Rotation of connection box through 180°	<b>K85</b>						✓	✓	✓	✓	✓	✓	✓	✓	✓	✓
Next larger connection box	<b>L00</b>						–	–	–	–	✓	✓	✓	✓	✓	✓
External earthing	<b>L13</b>						□	□	□	□	□	□	□	□	□	□
Auxiliary connection box 1XB3 020	<b>L97</b>						–	–	–	–	✓	✓	✓	✓	✓	✓
Saddle terminal for connection without cable lug, accessories pack (6 items)	<b>M47</b>						–	–	–	–	–	–	–	✓ <sup>9)</sup>	✓ <sup>9)</sup>	✓ <sup>9)</sup>
<b>Windings and insulation</b>																
Increased air humidity/temperature with 30 to 60 g water per m <sup>3</sup> of air	<b>C19</b>						✓	✓	✓	✓	✓	✓	✓	✓	✓	✓
Temperature class 155 (F), used acc. to 130 (B), coolant temperature 45 °C, derating approx. 4 %	<b>C22</b>						✓	✓	✓	✓	✓	✓	✓	✓	✓	✓
Temperature class 155 (F), used acc. to 130 (B), coolant temperature 50 °C, derating approx. 8 %	<b>C23</b>						✓	✓	✓	✓	✓	✓	✓	✓	✓	✓
Temperature class 155 (F), used acc. to 130 (B), coolant temperature 55 °C, derating approx. 13 %	<b>C24</b>						✓	✓	✓	✓	✓	✓	✓	✓	✓	✓
Temperature class 155 (F), used acc. to 130 (B), coolant temperature 60 °C, derating approx. 18 %	<b>C25</b>						✓	✓	✓	✓	✓	✓	✓	✓	✓	✓
Increased air humidity/temperature with 60 to 100 g water per m <sup>3</sup> of air	<b>C26</b>						✓	✓	✓	✓	✓	✓	✓	✓	✓	✓
Temperature class 155 (F), used acc. to 130 (B), with increased coolant temperature and/or site altitude	<b>Y50 •</b> and specified output, CT... °C or SA .... m above sea level						✓	✓	✓	✓	✓	✓	✓	✓	✓	✓

For legend and footnotes, see Page 4/119.



# IEC Squirrel-Cage Motors

## Explosion-proof motors

### Special versions

Special versions	Additional identification code -Z with order code and plain text if required	Motor type frame size																		
		56	63	71	80	90	100	112	132	160	180	200	225	250	280	315				
<b>Self-ventilated motors in Zones 2, 21, 22 with type of protection "n" or protection against dust explosions – Cast-iron series 1LA6 and 1LG4</b>																				
											<b>1LA6 (cast-iron)</b>	<b>1LG4 (cast-iron)</b>								
<b>Colors and paint finish</b>																				
Standard finish in RAL 7030 stone gray											–	–	–	–	☐	☐	☐	☐	☐	☐
Standard finish in other standard RAL colors: RAL 1002, 1013, 1015, 1019, 2003, 2004, 3000, 3007, 5007, 5009, 5010, 5012, 5015, 5017, 5018, 5019, 6011, 6019, 6021, 7000, 7001, 7004, 7011, 7016, 7022, 7031, 7032, 7033, 7035, 9001, 9002, 9005 Page 0/18	<b>Y53 •</b> and standard finish RAL ....										–	–	–	–	✓	✓	✓	✓	✓	✓
Special finish in RAL 7030 stone gray <sup>10)</sup>	<b>K26</b>										☐	☐	☐	☐	✓	✓	✓	✓	✓	✓
Special finish in other standard RAL colors: RAL 1002, 1013, 1015, 1019, 2003, 2004, 3000, 3007, 5007, 5009, 5010, 5012, 5015, 5017, 5018, 5019, 6011, 6019, 6021, 7000, 7001, 7004, 7011, 7016, 7022, 7031, 7032, 7033, 7035, 9001, 9002, 9005 Page 0/18	<b>Y54 •</b> and special finish RAL ....										✓	✓	✓	✓	✓	✓	✓	✓	✓	✓
Special finish in special RAL colors: For RAL colors, see "Special finish in special RAL colors" on Page 0/19	<b>Y51 •</b> and special finish RAL ....										✓	✓	✓	✓	✓	✓	✓	✓	✓	✓
Offshore special finish	<b>M91</b>										O. R.	O. R.	O. R.	O. R.	✓	✓	✓	✓	✓	✓
Sea air resistant special finish	<b>M94</b>										O. R.	O. R.	O. R.	O. R.	O. R.	O. R.	O. R.	O. R.	O. R.	O. R.
Unpainted (only cast iron parts primed)	<b>K23</b>										○	○	○	○	○	○	○	○	○	○
Unpainted, only primed	<b>K24</b>										✓	✓	✓	✓	✓	✓	✓	✓	✓	✓
<b>Special technology</b>																				
Mounting of explosion-proof rotary pulse encoder for use in Zones 2, 21, 22 <sup>11)</sup>	<b>H86</b>										✓	✓	✓	✓	✓	✓	✓	✓	✓	✓
Mounting of explosion-proof separately driven fan Ex nA for use in Zone 2 <sup>12)</sup>	<b>M95</b>										–	–	–	–	–	–	✓	✓	✓	✓
Mounting of explosion-proof separately driven fan II 2D for use in Zone 21 <sup>12)</sup>	<b>M96</b>										–	–	–	–	–	–	✓	✓	✓	✓
Mounting of explosion-proof separately driven fan II 3D for use in Zone 22 <sup>12)</sup>	<b>M97</b>										✓	✓	✓	✓	✓	✓	✓	✓	✓	✓
<b>Mechanical design and degrees of protection</b>																				
Drive-end seal for flange-mounting motors with an oil-tightness of up to 0.1 bar Not possible for IM V3 type of construction <sup>13)</sup>	<b>K17</b>										✓	✓	✓	✓	✓	✓	✓	✓	✓	✓
Low-noise version for 2-pole motors with clockwise direction of rotation <sup>14)</sup>	<b>K37</b>										–	–	✓	✓	✓	✓	✓	✓	✓	✓
Low-noise version for 2-pole motors with counter-clockwise direction of rotation <sup>14)</sup>	<b>K38</b>										–	–	✓	✓	✓	✓	✓	✓	✓	✓
IP65 degree of protection <sup>15)</sup>	<b>K50</b>										✓	✓	✓	✓	✓	✓	✓	✓	✓	✓
IP56 degree of protection (non-heavy-sea) <sup>16)</sup>	<b>K52</b>										✓	✓	✓	✓	✓	✓	✓	✓	✓	✓
Vibration-proof version	<b>L03</b>										✓	✓	✓	✓	–	–	–	–	–	–
Condensation drainage holes <sup>17)</sup>	<b>L12</b>										✓	✓	✓	✓	☐	☐	☐	☐	☐	☐
Rust-resistant screws (externally)	<b>M27</b>										✓	✓	✓	✓	✓	✓	✓	✓	✓	✓
Mechanical protection for encoder <sup>18)</sup>	<b>M68</b>										✓	✓	✓	✓	✓	✓	✓	✓	✓	✓

# IEC Squirrel-Cage Motors

## Explosion-proof motors

### Special versions

Special versions	Additional identification code -Z with order code and plain text if required	Motor type frame size														
		56	63	71	80	90	100	112	132	160	180	200	225	250	280	315
<b>Self-ventilated motors in Zones 2, 21, 22 with type of protection "n" or protection against dust explosions – Cast-iron series 1LA6 and 1LG4</b>																
<b>Coolant temperature and site altitude</b>																
Coolant temperature -40 °C to +40 °C for EX motor <sup>19)</sup>	<b>D19</b>															
<b>Designs in accordance with standards and specifications</b>																
Electrical according to NEMA MG1-12	<b>D30</b>															
Ex certification for China (only valid for Zone 2)	<b>D32</b>															
<b>Bearings and lubrication</b>																
Measuring nipple for SPM shock pulse measurement for bearing inspection	<b>G50</b>															
Bearing design for increased cantilever forces <sup>20)</sup>	<b>K20</b>															
Special bearing for DE and NDE, bearing size	<b>K36</b>														✓ <sup>21)</sup>	✓ <sup>21)</sup>
Regreasing device	<b>K40</b>														□	□
Located bearing DE	<b>K94</b>														✓	✓
Located bearing NDE	<b>L04</b>														□	□
Insulated bearing cartridge	<b>L27</b>														✓	✓
<b>Balance and vibration quantity</b>																
Vibration quantity A																
Vibration quantity B <sup>22)</sup>	<b>K02</b>															
Full key balancing	<b>L68</b>															
Balancing without key	<b>M37</b>															
<b>Shaft and rotor</b>																
Concentricity of shaft extension, coaxiality and linear movement in accordance with DIN 42955 Tolerance R for flange-mounting motors <sup>23)</sup>	<b>K04</b>															
Second standard shaft extension <sup>24)</sup>	<b>K16</b>															
Shaft extension with standard dimensions without featherkey way	<b>K42</b>															
Concentricity of shaft extension in accordance with DIN 42955 Tolerance R	<b>L39</b>															
Standard shaft made of rust-resistant steel	<b>M65</b>															
Non-standard cylindrical shaft extension <sup>25)</sup>	<b>Y55 • and identification code</b>															
<b>Heating and ventilation</b>																
Fan cover for textile industry	<b>H17</b>															
Metal external fan <sup>26)</sup>	<b>K35</b>															
Anti-condensation heater, Ex. 230 V	<b>M15</b>															
Anti-condensation heater, Ex. 115 V	<b>M14</b>															
Separately driven fan with non-standard voltage and/or frequency	<b>Y81 • and identification code</b>															
<b>Rating plate and extra rating plates</b>																
Second lubricating plate, supplied loose	<b>B06</b>															
Second rating plate, loose	<b>K31</b>															
Extra rating plate or rating plate with deviating rating plate data	<b>Y80 • and identification code</b>															
Extra rating plate with identification code	<b>Y82 • and identification code</b>															
Additional information on rating plate and on package label (maximum of 20 characters)	<b>Y84 • and identification code</b>															

For legend and footnotes, see Page 4/119.

# IEC Squirrel-Cage Motors

## Explosion-proof motors

### Special versions

Special versions	Additional identification code <b>-Z</b> with order code and plain text if required	Motor type frame size														
		56	63	71	80	90	100	112	132	160	180	200	225	250	280	315
<b>Self-ventilated motors in Zones 2, 21, 22 with type of protection "n" or protection against dust explosions – Cast-iron series 1LA6 and 1LG4</b>																
<b>Packaging, safety notes, documentation and test certificates</b>																
Acceptance test certificate 3.1 according to EN 10204	<b>B02</b>															
Operating instructions German/English enclosed in print	<b>B23</b>															
Type test with heat run for horizontal motors, with acceptance	<b>F83</b>															
Wire-lattice pallet	<b>L99</b>															
Connected in star for dispatch	<b>M32</b>															
Connected in delta for dispatch	<b>M33</b>															

- Standard version
- Without additional charge
- This order code only determines the price of the version – Additional plain text is required.
- R. Possible on request
- ✓ With additional charge
- Not possible

- 1) Only permitted for use in accordance with temperature class 130 (B).
- 2) These motors do not have a rated voltage range stamped on the rating plate.
- 3) According to the standard, the motor and converter must be tested as a unit. A "Manufacturer test certificate" is available for a defined spectrum of Siemens motors (frame sizes 63 M to 315 L)/converter. Please inquire in the case of a non-Siemens converter (additional charge).
- 4) With this option, PTC thermistors for temperature class 130 (B) are included. For compliance with temperature class 130 (B), derating is necessary in the case of converter-fed operation in Zones 2, 21 and 22. The operating data for the MICROMASTER converter series from Siemens are specified on the rating plate as standard. Derating information is available on request. For converter-fed operation only voltage codes/order codes with only one voltage are permitted, see also Page 4/82.
- 5) In combination with order codes **D19, K30, M95, M96 and M97** please inquire. Not possible in combination with order codes **D32, K50 and K52**.
- 6) Zone 21 takes into account conducting and non-conducting dust.
- 7) Evaluation with appropriate tripping unit (see Catalog LV 1) is recommended. When used in hazardous areas, a certified tripping unit is required. KTY 84-130 and PT 100 are not permitted as sole protection. Full motor protection for mains-fed operation implemented only with PTC thermistors, please inquire.
- 8) For 1LA6 and 1LG6 motors additional charge only applies to Zone 22. Designs for Zones 2 and 21 already have a certified metal cable gland in the standard version. Standard with designs for Zone 2, Zone 21 and VIK.
- 9) Standard with designs for Zone 2, Zone 21 and VIK.
- 10) For frame sizes 100 to 160, do not specify an order code. Order code is only necessary for frame sizes 180 to 315.
- 11) In combination with order codes **C19, C26, L27, M95, M96 and M97** please inquire. Not possible in combination with order code **K16**. Furthermore a combination with protective cover is not possible. Therefore a suitable cover must be implemented by the end user in vertical mounting position to prevent small parts from falling into the fan cover (see the standard IEC/EN 60079-0).
- 12) In combination with order codes **C19, C22, C23, C24, C25, C26, C27, D19, H86, K30, K50 and K52** please inquire. Not possible in combination with order code **K16**. The type of protection of the separately driven fan must correspond to the type of protection of the motor.
- 13) Not possible for motor series 1LG4 for 2-pole motors.
- 14) For 1LG4 motors a second shaft extension is not possible in the low-noise version.
- 15) Order code **K50** (IP65 degree of protection) can only be ordered for Zone 2. For Zone 21, IP65 degree of protection is standard. Not possible for Zone 22, because only IP55 degree of protection is required.
- 16) Order code **K52** IP56 degree of protection (non-heavy-sea) is only possible for Zone 2. Not admissible for Zone 21 (IP65 degree of protection) and Zone 22 (IP55 degree of protection).
- 17) For 1LA6 motors: When supplied the condensation drainage holes are sealed at the drive end DE and non-drive end NDE for IP55, IP56 and IP65 degrees of protection. If condensation drainage holes are required in motors of the IM B6, IM B7 or IM B8 type of construction (feet located on side or top), it is necessary to relocate the bearing plates at the drive end (DE) and non-drive end (NDE) so that the condensation drainage holes situated between the feet on delivery are underneath.
- 18) Not necessary when a rotary pulse encoder is combined with a separately driven fan, because in this case the rotary pulse encoder is installed under the fan cover.
- 19) Not possible in combination with order code **L03**.
- 20) Not possible for 2-pole 1LG4 motors, frame size 315 L in vertical types of construction; bearings for increased cantilever forces at vibration quantity level B available on request for 1LG4 motors. Not possible for 1LG4 motors in the combination "Concentricity of the shaft extension, coaxiality and linear movement in accordance with DIN 42955 Tolerance R for flange-mounting motors" – order code **K04**.
- 21) Additional charge for 2-pole motors. With 4-pole to 8-pole motors, standard version.
- 22) Not possible in combination with parallel roller bearings (e.g. bearings for increased cantilever forces, order code **K20**).
- 23) Can be combined with deep-groove bearings of series 60.., 62.. and 63... Not possible in combination with parallel roller bearings (e.g. bearings for increased cantilever forces, order code **K20**).
- 24) Possible for motors of frame size 315 and above in vertical types of construction or 2-pole for version with second shaft extension on request. Version with protective cover not possible.
- 25) When motors which have a longer or shorter shaft extension than normal are ordered, the required position and length of the featherkey way must be specified in a sketch. It must be ensured that only featherkeys in accordance with DIN 6885, Form A are permitted to be used. The featherkey way is positioned centrally on the shaft extension. The length is defined by the manufacturer normatively. Not valid for: Conical shafts, non-standard threaded journals, non-standard shaft tolerances, friction welded journals, extremely "thin" shafts, special geometry dimensions (e.g. square journals), hollow shafts. Valid for non-standard shaft extensions DE or NDE. The featherkeys are supplied in every case. For order codes **Y55 and K16**:  
– Dimensions D and DA ≤ internal diameter of roller bearing (see dimension tables under "Dimensions")  
– Dimensions E and EA ≤ 2 x length E (normal) of the shaft extension  
For an explanation of the order codes, see catalog part 0 "Introduction".
- 26) For 1LA5/6/7/9 motors and 1LG with metal external fan, converter-fed operation is permitted. The metal external fan is standard for these motors in the version for Zone 21/22. The metal external fan is not possible in combination with the low-noise version – order code **K37** or **K38**.

# IEC Squirrel-Cage Motors

## Explosion-proof motors

### Special versions

Special versions	Additional identification code <b>-Z</b> with order code and plain text if required	Motor type frame size													
		56	63	71	80	90	100	112	132	160	180	200	225	250	280
<b>Self-ventilated motors in Zones 2, 21 and 22 with type of protection "n" or protection against dust explosions – Cast-iron series 1LG6</b>															
														<b>1LG6 (cast-iron)</b>	
<b>Design for Zones 1, 2, 21 and 22 according to ATEX <sup>1)</sup></b>															
Design for Zone 2 for mains-fed operation Ex nA II T3 to IEC/EN 60079-15 <sup>2)</sup>	<b>M72</b>														
Design for Zone 2 for converter-fed operation, reduced output Ex nA II T3 to IEC/EN 60079-15 <sup>2) 3) 4)</sup>	<b>M73</b>														
Design for Zones 2 and 22, for non-conducting dust (IP55), for mains-fed operation <sup>5)</sup>	<b>M74</b>														
Design for Zones 2 and 22, for non-conducting dust (IP55), for converter-fed operation, derating <sup>4) 5)</sup>	<b>M75</b>														
Design for Zone 21, as well as Zone 22 for conducting dust (IP65) for mains-fed operation <sup>6)</sup>	<b>M34</b>														
Design for Zone 21, as well as Zone 22 for conducting dust (IP65) for converter-fed operation, derating <sup>2) 4) 6)</sup>	<b>M38</b>														
Design for Zone 22 for non-conducting dust (IP55) for mains-fed operation	<b>M35</b>														
Design for Zone 22 for non-conducting dust (IP55) for converter-fed operation, derating <sup>2) 4)</sup>	<b>M39</b>														
VIK design (comprises Zone 2 for mains-fed operation, without Ex nA II marking on rating plate)	<b>K30</b>														
Ex nA II on VIK rating plate	<b>C27</b>														
Alternative converter (SIMOVERT MASTERDRIVES, SIMOVERT S120)	<b>Y68 • and converter type ....</b>														
<b>Motor protection</b>															
With PTC thermistors for alarm for converter-fed operation in Zones 2, 21, 22 <sup>7)</sup>	<b>A10</b>														
Motor protection with PTC thermistors with 3 embedded temperature sensors for tripping <sup>7)</sup>	<b>A11</b>														
Motor protection with PTC thermistors with 6 embedded temperature sensors for alarm and tripping <sup>7)</sup>	<b>A12</b>														
Motor temperature detection with embedded temperature sensor KTY 84-130 <sup>7)</sup>	<b>A23</b>														
Motor temperature detection with embedded temperature sensors 2 x KTY 84-130 <sup>7)</sup>	<b>A25</b>														
Installation of 3 PT 100 resistance thermometers <sup>7)</sup>	<b>A60</b>														
Installation of 6 PT 100 resistance thermometers in stator winding <sup>7)</sup>	<b>A61</b>														
Installation of 2 PT 100 screw-in resistance thermometers (basic circuit) for rolling-contact bearings <sup>7)</sup>	<b>A72</b>														
Installation of 2 PT 100 screw-in resistance thermometers (3-wire circuit) for rolling-contact bearings <sup>7)</sup>	<b>A78</b>														
Installation of 2 PT 100 double screw-in resistance thermometers (three-wire circuit) for rolling-contact bearings <sup>7)</sup>	<b>A80</b>														

4

For legend, see Page 4/123, for footnotes, see Page 4/124.

# IEC Squirrel-Cage Motors

## Explosion-proof motors

### Special versions

Special versions	Additional identification code <b>-Z</b> with order code and plain text if required	Motor type frame size													
		56	63	71	80	90	100	112	132	160	180	200	225	250	280
<b>Self-ventilated motors in Zones 2, 21 and 22 with type of protection "n" or protection against dust explosions – Cast-iron series 1LG6</b>															
															<b>1LG6 (cast-iron)</b>
<b>Motor connection and connection box</b>															
Two-part plate on connection box	<b>K06</b>	–	✓	✓	✓	✓	✓	✓	✓	✓	✓	✓	✓	✓	✓
Connection box on RHS	<b>K09</b>	✓	✓	✓	✓	✓	✓	✓	✓	✓	✓	✓	✓	✓	✓
Connection box on LHS	<b>K10</b>	✓	✓	✓	✓	✓	✓	✓	✓	✓	✓	✓	✓	✓	✓
Connection box on top, feet screwed on	<b>K11</b>	✓	✓	✓	✓	✓	✓	✓	✓	✓	✓	✓	✓	✓	✓
Connection box in cast-iron version	<b>K15</b>	✓	✓	✓	✓	✓	□	□	□	□	□	□	□	□	□
One cable gland, metal <sup>8)</sup>	<b>K54</b>	✓	✓	✓	✓	✓	✓	✓	✓	✓	✓	✓	✓	✓	✓
Cable gland, maximum configuration <sup>8)</sup>	<b>K55</b>	O. R.	O. R.	O. R.	O. R.	O. R.	O. R.	O. R.	O. R.	O. R.	O. R.	O. R.	O. R.	O. R.	O. R.
Rotation of the connection box through 90°, entry from DE	<b>K83</b>	✓	✓	✓	✓	✓	✓	✓	✓	✓	✓	✓	✓	✓	✓
Rotation of the connection box through 90°, entry from NDE	<b>K84</b>	✓	✓	✓	✓	✓	✓	✓	✓	✓	✓	✓	✓	✓	✓
Rotation of connection box through 180°	<b>K85</b>	✓	✓	✓	✓	✓	✓	✓	✓	✓	✓	✓	✓	✓	✓
Next larger connection box	<b>L00</b>	✓	✓	✓	✓	✓	✓	✓	✓	✓	✓	✓	✓	✓	✓
Auxiliary connection box	<b>L97</b>	✓	✓	✓	✓	✓	✓	✓	✓	✓	✓	✓	✓	✓	✓
Saddle terminal for connection without cable lug, accessories pack (6 items)	<b>M47</b>	–	–	–	–	–	–	–	–	–	–	–	–	–	–
<b>Windings and insulation</b>															
Increased air humidity/temperature with 30 to 60 g water per m <sup>3</sup> of air	<b>C19</b>	✓	✓	✓	✓	✓	✓	✓	✓	✓	✓	✓	✓	✓	✓
Temperature class 155 (F), used acc. to 130 (B), coolant temperature 45 °C, derating approx. 4 %	<b>C22</b>	✓	✓	✓	✓	✓	✓	✓	✓	✓	✓	✓	✓	✓	✓
Temperature class 155 (F), used acc. to 130 (B), coolant temperature 50 °C, derating approx. 8 %	<b>C23</b>	✓	✓	✓	✓	✓	✓	✓	✓	✓	✓	✓	✓	✓	✓
Temperature class 155 (F), used acc. to 130 (B), coolant temperature 55 °C, derating approx. 13 %	<b>C24</b>	✓	✓	✓	✓	✓	✓	✓	✓	✓	✓	✓	✓	✓	✓
Temperature class 155 (F), used acc. to 130 (B), coolant temperature 60 °C, derating approx. 18 %	<b>C25</b>	✓	✓	✓	✓	✓	✓	✓	✓	✓	✓	✓	✓	✓	✓
Increased air humidity/temperature with 60 to 100 g water per per m <sup>3</sup> of air	<b>C26</b>	✓	✓	✓	✓	✓	✓	✓	✓	✓	✓	✓	✓	✓	✓
Temperature class 155 (F), used acc. to 130 (B), with a higher coolant temperature and/or site altitude	<b>Y50 •</b> and specified output, CT ... °C or SA .... m above sea level	✓	✓	✓	✓	✓	✓	✓	✓	✓	✓	✓	✓	✓	✓
<b>Colors and paint finish</b>															
Standard finish in RAL 7030 stone gray		□	□	□	□	□	□	□	□	□	□	□	□	□	□
Standard finish in other standard RAL colors: RAL 1002, 1013, 1015, 1019, 2003, 2004, 3000, 3007, 5007, 5009, 5010, 5012, 5015, 5017, 5018, 5019, 6011, 6019, 6021, 7000, 7001, 7004, 7011, 7016, 7022, 7031, 7032, 7033, 7035, 9001, 9002, 9005 Page 0/18	<b>Y53 •</b> and standard finish RAL ....	✓	✓	✓	✓	✓	✓	✓	✓	✓	✓	✓	✓	✓	✓
Special finish in RAL 7030 stone gray	<b>K26</b>	✓	✓	✓	✓	✓	✓	✓	✓	✓	✓	✓	✓	✓	✓
Special finish in other standard RAL colors: RAL 1002, 1013, 1015, 1019, 2003, 2004, 3000, 3007, 5007, 5009, 5010, 5012, 5015, 5017, 5018, 5019, 6011, 6019, 6021, 7000, 7001, 7004, 7011, 7016, 7022, 7031, 7032, 7033, 7035, 9001, 9002, 9005 Page 0/18	<b>Y54 •</b> and special finish RAL ....	✓	✓	✓	✓	✓	✓	✓	✓	✓	✓	✓	✓	✓	✓
Special finish in special RAL colors: For RAL colors, see "Special finish in special RAL colors" on Page 0/19	<b>Y51 •</b> and special finish RAL ....	✓	✓	✓	✓	✓	✓	✓	✓	✓	✓	✓	✓	✓	✓
Offshore special finish	<b>M91</b>	✓	✓	✓	✓	✓	✓	✓	✓	✓	✓	✓	✓	✓	✓
Sea air resistant special finish	<b>M94</b>	O. R.	O. R.	O. R.	O. R.	O. R.	O. R.	O. R.	O. R.	O. R.	O. R.	O. R.	O. R.	O. R.	O. R.
Unpainted (only cast-iron parts primed)	<b>K23</b>	○	○	○	○	○	○	○	○	○	○	○	○	○	○
Unpainted, only primed	<b>K24</b>	✓	✓	✓	✓	✓	✓	✓	✓	✓	✓	✓	✓	✓	✓

For legend, see Page 4/123, for footnotes, see Page 4/124.

# IEC Squirrel-Cage Motors

## Explosion-proof motors

### Special versions

Special versions	Additional identification code <b>-Z</b> with order code and plain text if required	Motor type frame size															
		56	63	71	80	90	100	112	132	160	180	200	225	250	280	315	
<b>Self-ventilated motors in Zones 2, 21 and 22 with type of protection "n" or protection against dust explosions – Cast-iron series 1LG6</b>																	
<b>Special technology</b>																	
Mounting of explosion-proof rotary pulse encoder for use in Zones 2, 21, 22 <sup>10)</sup>	<b>H86</b>												✓	✓	✓	✓	✓
Mounting of explosion-proof separately driven fan Ex nA for use in Zone 2 <sup>11)</sup>	<b>M95</b>												–	–	✓	✓	✓
Mounting of explosion-proof separately driven fan II 2D for use in Zone 21 <sup>11)</sup>	<b>M96</b>												–	–	✓	✓	✓
Mounting of explosion-proof separately driven fan II 3D for use in Zone 22 <sup>11)</sup>	<b>M97</b>												✓	✓	✓	✓	✓
<b>Mechanical design and degrees of protection</b>																	
Drive-end seal for flange-mounting motors with an oil-tightness of up to 0.1 bar Not possible for IM V3 type of construction and 2-pole motors	<b>K17</b>												✓	✓	✓	✓	✓
Low-noise version for 2-pole motors with clockwise direction of rotation <sup>12)</sup>	<b>K37</b>												–	–	–	–	–
Low-noise version for 2-pole motors with counter-clockwise direction of rotation <sup>12)</sup>	<b>K38</b>												–	–	–	–	–
IP65 degree of protection <sup>13)</sup>	<b>K50</b>												✓	✓	✓	✓	✓
IP56 degree of protection (non-heavy-sea) <sup>14)</sup>	<b>K52</b>												✓	✓	✓	✓	✓
Condensation water holes <sup>15)</sup>	<b>L12</b>												□	□	□	□	□
Rust-resistant screws (externally)	<b>M27</b>												✓	✓	✓	✓	✓
Mechanical protection for encoder <sup>16)</sup>	<b>M68</b>												✓	✓	✓	✓	✓
<b>Coolant temperature and site altitude</b>																	
Coolant temperature –40 °C to +40 °C for EX motor <sup>17)</sup>	<b>D19</b>												✓	✓	✓	✓	✓
<b>Designs in accordance with standards and specifications</b>																	
Electrical according to NEMA MG1-12 (standard version with EPACT)	<b>D30</b>												□	□	□	□	□
Ex certification for China (only valid for Zone 2)	<b>D32</b>												✓	✓	✓	✓	✓
<b>Bearings and lubrication</b>																	
Measuring nipple for SPM shock pulse measurement for bearing inspection	<b>G50</b>												✓	✓	✓	✓	✓
Bearing design for increased cantilever forces <sup>18)</sup>	<b>K20</b>												✓	✓	✓	✓	✓
Special bearing for DE and NDE, bearing size	<b>K36</b>												✓	✓	✓	✓	✓ <sup>19)</sup> ✓ <sup>19)</sup>
Regreasing device	<b>K40</b>												✓	✓	✓	✓	□
Located bearing DE	<b>K94</b>												✓	✓	✓	✓	✓
Located bearing NDE	<b>L04</b>												□	□	□	□	□
Insulated bearing cartridge	<b>L27</b>												–	–	✓	✓	✓
<b>Balance and vibration quantity</b>																	
Vibration quantity A													□	□	□	□	□
Vibration quantity B <sup>20)</sup>	<b>K02</b>												✓	✓	✓	✓	✓
Full key balancing	<b>L68</b>												✓	✓	✓	✓	✓
Balancing without key	<b>M37</b>												✓	✓	✓	✓	✓
<b>Shaft and rotor</b>																	
Concentricity of shaft extension, coaxiality and linear movement in accordance with DIN 42955 Tolerance R for flange-mounting motors <sup>21)</sup>	<b>K04</b>												✓	✓	✓	✓	✓
Second standard shaft extension <sup>22)</sup>	<b>K16</b>												✓	✓	✓	✓	✓
Shaft extension with standard dimensions without featherkey way	<b>K42</b>												✓	✓	✓	✓	✓
Concentricity of shaft extension in accordance with DIN 42955 Tolerance R	<b>L39</b>												✓	✓	✓	✓	✓
Non-standard cylindrical shaft extension <sup>23)</sup>	<b>Y55 •</b> and identification code												✓	✓	✓	✓	✓

For legend, see Page 4/123, for footnotes, see Page 4/124.

# IEC Squirrel-Cage Motors

## Explosion-proof motors

### Special versions

Special versions	Additional identification code <b>-Z</b> with order code and plain text if required	Motor type frame size													
		56	63	71	80	90	100	112	132	160	180	200	225	250	280
<b>Self-ventilated motors in Zones 2, 21 and 22 with type of protection "n" or protection against dust explosions – Cast-iron series 1LG6</b>															
														<b>1LG6 (cast-iron)</b>	
<b>Heating and ventilation</b>															
Metal external fan <sup>24)</sup>	<b>K35</b>	✓	✓	✓	✓	✓	✓	✓	✓	✓	✓	✓	✓	✓	✓
Anti-condensation heater, Ex. 230 V	<b>M15</b>	O. R.	O. R.	O. R.	O. R.	O. R.	O. R.	O. R.	O. R.	O. R.	O. R.	O. R.	O. R.	O. R.	O. R.
Anti-condensation heater, Ex. 115 V	<b>M14</b>	O. R.	O. R.	O. R.	O. R.	O. R.	O. R.	O. R.	O. R.	O. R.	O. R.	O. R.	O. R.	O. R.	O. R.
Separately driven fan with non-standard voltage and/or frequency	<b>Y81 •</b> and identification code	–	–	✓	✓	✓	✓	✓	✓	✓	✓	✓	✓	✓	✓
<b>Rating plate and extra rating plates</b>															
Second lubricating plate, supplied loose	<b>B06</b>	✓	✓	✓	✓	✓	✓	✓	✓	✓	✓	✓	✓	✓	✓
Second rating plate, loose	<b>K31</b>	✓	✓	✓	✓	✓	✓	✓	✓	✓	✓	✓	✓	✓	✓
Extra rating plate or rating plate with deviating rating plate data	<b>Y80 •</b> and identification code	✓	✓	✓	✓	✓	✓	✓	✓	✓	✓	✓	✓	✓	✓
Extra rating plate with identification code	<b>Y82 •</b> and identification code	✓	✓	✓	✓	✓	✓	✓	✓	✓	✓	✓	✓	✓	✓
Additional information on rating plate and on package label (maximum of 20 characters)	<b>Y84 •</b> and identification code	✓	✓	✓	✓	✓	✓	✓	✓	✓	✓	✓	✓	✓	✓
<b>Packaging, safety notes, documentation and test certificates</b>															
Acceptance test certificate 3.1 according to EN 10204	<b>B02</b>	✓	✓	✓	✓	✓	✓	✓	✓	✓	✓	✓	✓	✓	✓
Operating instructions German/English enclosed in print	<b>B23</b>	□	□	□	□	□	□	□	□	□	□	□	□	□	□
Type test with heat run for horizontal motors, with acceptance	<b>F83</b>	✓	✓	✓	✓	✓	✓	✓	✓	✓	✓	✓	✓	✓	✓
Connected in star for dispatch	<b>M32</b>	✓	✓	✓	✓	✓	✓	✓	✓	✓	✓	✓	✓	✓	✓
Connected in delta for dispatch	<b>M33</b>	✓	✓	□	□	□	□	□	□	□	□	□	□	□	□

- Standard version
- Without additional charge
- This order code only determines the price of the version – Additional plain text is required.
- O. R. Possible on request
- ✓ With additional charge
- Not possible

# IEC Squirrel-Cage Motors

## Explosion-proof motors

### Special versions

4

- 1) Only permitted for use in accordance with temperature class 130 (B).
- 2) These motors do not have a rated voltage range stamped on the rating plate.
- 3) According to the standard, the motor and converter must be tested as a unit. A "Manufacturer test certificate" is available for a defined spectrum of Siemens motors (frame sizes 63 M to 315 L)/converter. Please inquire in the case of a non-Siemens converter (additional charge).
- 4) With this option, PTC thermistors for temperature class 130 (B) are included. For compliance with temperature class 130 (B), derating is necessary in the case of converter-fed operation in Zones 2, 21 and 22. Derating information is available on request.
- 5) In combination with order codes **D19, K30, M95, M96** and **M97** please inquire. Not possible in combination with order codes **D32, K50** and **K52**. Zone 21 takes into account conducting and non-conducting dust.
- 6) Evaluation with appropriate tripping unit (see Catalog LV 1) is recommended. When used in hazardous areas, a certified tripping unit is required. KTY 84-130 and PT 100 are not permitted as sole protection. Full motor protection for mains-fed operation implemented only with PTC thermistors, please inquire.
- 8) For 1LG6 motors, additional charge only applies to Zone 22. Designs for Zones 2 and 21 already have a cable entry in the standard version.
- 9) Standard with designs for Zone 2, Zone 21 and VIK.
- 10) In combination with order codes **C19, C26, L27, M95, M96** and **M97** please inquire. Not possible in combination with order code **K16**. Furthermore a combination with protective cover is not possible. Therefore a suitable cover must be implemented by the end user in vertical mounting position to prevent small parts from falling into the fan cover (see the standard IEC/EN 60079-0).
- 11) In combination with order codes **C19, C22, C23, C24, C25, C26, D19, H86, K50** and **K52** please inquire. Not possible in combination with order code **K16**. The type of protection of the separately driven fan must correspond to the type of protection of the motor.
- 12) Not necessary for 1LG6 motors because these motors are already noise optimized.
- 13) Order code **K50** (IP65 degree of protection) can only be ordered for Zone 2. For Zone 21, IP65 degree of protection is standard. Not possible for Zone 22, because only IP55 degree of protection is required.
- 14) Order code **K52** IP56 degree of protection (non-heavy-sea) is only possible for Zone 2. Not admissible for Zone 21 (IP65 degree of protection) and Zone 22 (IP55 degree of protection).
- 15) When supplied the condensation drainage holes are sealed at the drive end DE and non-drive end NDE (IP55, IP56, IP65). If condensation drainage holes are required in motors of the IM B6, IM B7 or IM B8 type of construction (feet located on side or top), it is necessary to relocate the bearing plates at the drive end (DE) and non-drive end (NDE) so that the condensation drainage holes situated between the feet on delivery are underneath.
- 16) Not necessary when a rotary pulse encoder is combined with a separately driven fan, because in this case the rotary pulse encoder is installed under the fan cover.
- 17) Not possible in combination with order code **L03**.
- 18) Not possible for 2-pole 1LG6 motors, frame size 315 L in vertical types of construction; bearings for increased cantilever forces at vibration quantity level B available on request for 1LG6 motors. Not possible for 1LG6 motors in the combination "Concentricity of the shaft extension, coaxiality and linear movement in accordance with DIN 42955 Tolerance R for flange-mounting motors" – order code **K04**.
- 19) Additional charge for 2-pole motors. With 4-pole to 8-pole motors, standard version.
- 20) Can be combined with deep-groove bearings of series 60.., 62.. and 63... Not possible with parallel roller bearings (e.g. bearings for increased cantilever forces, order code **K20**).
- 21) Not possible in combination with parallel roller bearings (e.g. bearings for increased cantilever forces, order code **K20**).
- 22) Possible for motors of frame size 315 and above in vertical types of construction or 2-pole for version with second shaft extension on request. Version with protective cover not possible.
- 23) When motors which have a longer or shorter shaft extension than normal are ordered, the required position and length of the featherkey way must be specified in a sketch. It must be ensured that only featherkeys in accordance with DIN 6885, Form A are permitted to be used. The featherkey way is positioned centrally on the shaft extension. The length is defined by the manufacturer normatively. Not valid for: Conical shafts, non-standard threaded journals, non-standard shaft tolerances, friction welded journals, extremely "thin" shafts, special geometry dimensions (e.g. square journals), hollow shafts. Valid for non-standard shaft extensions DE or NDE. The featherkeys are supplied in every case.  
For order codes **Y55** and **K16**:  
– Dimensions D and DA ≤ internal diameter of roller bearing (see dimension tables under "Dimensions")  
– Dimensions E and EA ≤ 2 x length E (normal) of the shaft extension  
For an explanation of the order codes, see catalog part 0 "Introduction".
- 24) For 1LA5/6/7/9 motors and 1LG with metal external fan, converter-fed operation is permitted. The metal external fan is standard for these motors in the version for Zone 21/22. The metal external fan is not possible in combination with the low-noise version – order code **K37** or **K38**.



### Overview

#### *Slide rails with fixing bolts and tensioning screws to DIN 42923*

Slide rails are used to tension the belt of a machine easily and conveniently when a belt tightener is not available. They are fixed to the base using stone bolts or foundation blocks.

The assignment of slide rails to motor size can be found in DIN 42923. For motors of frame sizes 355 to 450, there are no standardized slide rails (please inquire).

Available from:

Lütgert & Co. GmbH  
Postfach 42 51  
33276 Gütersloh, Germany  
Tel. +49 (0)5241-7407-0  
Fax +49 (0)5241-7407-90

<http://www.luetgert-antriebe.de>  
e-mail: [info@luetgert-antriebe.de](mailto:info@luetgert-antriebe.de)

#### *Foundation block acc. to DIN 799*

The foundation blocks are inserted into the stone foundation and embedded in concrete. They are used for fixing machines of medium size, slide rails, pedestal bearings, baseframes, etc. After the fixing bolts have been unscrewed, the machine can be dragged without it having to be lifted.

When the machine is initially installed, the foundation block that is bolted to the machine (without washers) and fitted with taper pins is not embedded with concrete until the machine has been fully aligned. In this case, the machine is positioned 2 to 3 mm lower. The difference in shaft height is compensated by inserting shims on final installation. The taper pins safeguard the exact position of the machine when it is repeatedly removed and replaced without the need for realignment.

Available from:

Lütgert & Co. GmbH  
Postfach 42 51  
33276 Gütersloh, Germany  
Tel. +49 (0)5241-7407-0  
Fax +49 (0)5241-7407-90

<http://www.luetgert-antriebe.de>  
e-mail: [info@luetgert-antriebe.de](mailto:info@luetgert-antriebe.de)

#### *Taper pins to DIN 258 with threaded ends and constant taper lengths*

Taper pins are used for components that are repeatedly removed. The drilled hole is ground conical using a conical reamer until the pin can be pushed in by hand until the cone shoulder lies 3 to 4 mm above the rim of the hole.

It can then be driven in using a hammer until it is correctly seated. The pin is removed from the drilled hole by screwing on the nut and tightening it.

Standardized taper pins are available from general engineering suppliers.

Source, for example:

Otto Roth GmbH & Co. KG  
Rutesheimer Straße 22  
70499 Stuttgart, Germany  
Tel. +49 (0)7 11-1388-0  
Fax +49 (0)7 11-1388-233

<http://www.ottoroth.de>  
e-mail: [info@ottoroth.de](mailto:info@ottoroth.de)

#### *Couplings for use in hazardous areas*

The motor from Siemens is connected to the machine or gear unit through a coupling. Flender is an important coupling manufacturer with a wide range of products. For standard applications, Siemens recommends that elastic couplings of Flender types N-Eupex and Rupex or torsionally rigid couplings of types Arpex and Zapex are used. For special applications, Fludex and Elpex-S couplings are recommended. These coupling types are suitable for use in areas subject to explosion hazards and are offered with declaration of conformity and type test certificate according to directive 94/9/EU.

Source of supply:

Siemens contact partner – ordering from Catalog  
Siemens MD 10.1 "FLENDER Standard Couplings"

or

A. Friedr. Flender AG  
Kupplungswerk Mussum  
Industriepark Bocholt  
Schlavenhorst 100  
46395 Bocholt, Germany  
Tel. +49 (0)2871-92 2185  
Fax +49 (0)2871-92 2579

<http://www.flender.com>  
e-mail: [couplings@flender.com](mailto:couplings@flender.com)

# IEC Squirrel-Cage Motors

## Explosion-proof motors

### Accessories

#### More information

##### *Spare motors and repair parts*

- Supply commitment for spare motors and repair parts following delivery of the motor
  - For up to 5 years, in the event of total motor failure, Siemens will supply a comparable motor with regard to the mounting dimensions and functions (the type series may vary).
  - Repair parts will be supplied for up to 5 years.
  - For up to 10 years, Siemens will provide information and will, if necessary, supply documentation for repair parts.
- When repair parts are ordered, the following details must be provided:
  - Designation and part number
  - Order No. and factory number of the motor

Example for ordering a fan cover 1LA7,  
frame size 160 M, 4-pole:

**Fan cover No. 7.40,  
1LA7 163-4AA60, factory number J783298901018**

- For bearing types, see the "Introduction".
- Repair parts for 1MJ6, 1MJ7, 1MJ8, 1MJ1, 1ME8, 1ML8, 1LG8 motors and smoke-extraction motors are available on request.
- For standard components, a supply commitment does not apply.
- Support – Hotline  
In Germany  
Tel.: 01 80/5 05 04 48

You will find telephone numbers for other countries on our Internet site

<http://www.siemens.com/automation/service&support>

# IEC Squirrel-Cage Motors

## Explosion-proof motors

### Dimensions

#### Overview

#### Overall dimensions

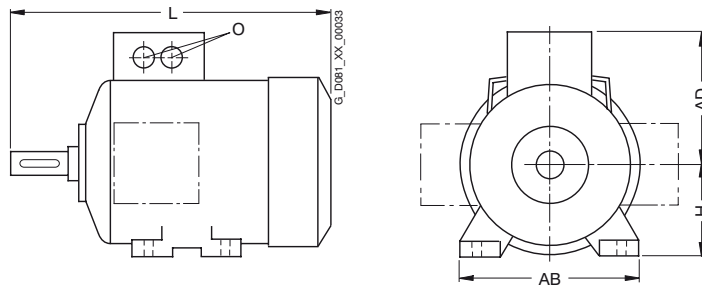

Frame size	Type	Number of poles	Dimensions					O
			L	AD	H	AB		
56 M	1LA7		169	101	56	110	1 x M16 x 1.5 1 x M25 x 1.5	
	1LA9 050		169	101	56	110	1 x M16 x 1.5 1 x M25 x 1.5	
	1LA9 053		195	101	56	110	1 x M16 x 1.5 1 x M25 x 1.5	
63 M	1LA7		202.5	101	63	120	1 x M16 x 1.5 1 x M25 x 1.5	
	1LA9 063		202.5	101	63	120	1 x M16 x 1.5 1 x M25 x 1.5	
	1LA9 061		228.5	101	63	120	1 x M16 x 1.5 1 x M25 x 1.5	
	1MA7		202.5	135	63	120	1 x M16 x 1.5 1 x M25 x 1.5	
71 M	1LA7		240	111	71	132	1 x M16 x 1.5 1 x M25 x 1.5	
	1LA9		240	111	71	132	1 x M16 x 1.5 1 x M25 x 1.5	
	1MA7		240	145	71	132	1 x M16 x 1.5 1 x M25 x 1.5	
	1MJ6		299	201	71	140	1 x M25 x 1.5 1 x M25 x 1.5	
80 M	1LA7		273.5	120	80	150	1 x M16 x 1.5 1 x M25 x 1.5	
	1LA9 080		273.5	120	80	150	1 x M16 x 1.5 1 x M25 x 1.5	
	1LA9 083		308.5	120	80	150	1 x M16 x 1.5 1 x M25 x 1.5	
	1MA7		273.5	154	80	150	1 x M16 x 1.5 1 x M25 x 1.5	
	1MA7 083-6.		308.5	154	80	150	1 x M16 x 1.5 1 x M25 x 1.5	
	1MJ6		336	209	80	160	1 x M25 x 1.5 1 x M25 x 1.5	
90 S/ 90 L	1LA7		331	128	90	165	1 x M16 x 1.5 1 x M25 x 1.5	
	1LA9		331	128	90	165	1 x M16 x 1.5 1 x M25 x 1.5	
	1LA9 096-6K.		376	128	90	165	1 x M16 x 1.5 1 x M25 x 1.5	
	1LA9 096-2...		358	128	90	165	1 x M16 x 1.5 1 x M25 x 1.5	
	1LA9 096-4...		358	128	90	165	1 x M16 x 1.5 1 x M25 x 1.5	
	1MA7		331	162	90	165	1 x M16 x 1.5 1 x M25 x 1.5	
	1MJ6		383	218	90	168	1 x M25 x 1.5 1 x M25 x 1.5	
	100 L	1LA6		372	164	100	196	2 x M32 x 1.5
1LA7			372	135	100	196	2 x M32 x 1.5	
1LA9			407	135	100	196	2 x M32 x 1.5	
1LA9 107-4KA.			442	135	100	196	2 x M32 x 1.5	
1MA6			372	164	100	196	2 x M32 x 1.5	
1MA7			372	135	100	196	2 x M32 x 1.5	
1MJ6			426	223	100	196	2 x M32 x 1.5 1 x M16 x 1.5	
112 M		1LA6		393	178	112	226	2 x M32 x 1.5
		1LA7		393	148	112	226	2 x M32 x 1.5
		1LA9		431	148	112	226	2 x M32 x 1.5
		1MA6		393	178	112	226	2 x M32 x 1.5
		1MA7		393	148	112	226	2 x M32 x 1.5
		1MJ6		428	238	112	226	2 x M32 x 1.5 1 x M16 x 1.5
		132 S/ 132 M	1LA6		453	194	132	256
	1LA7			452.5	167	132	256	2 x M32 x 1.5
	1LA9			452.5	167	132	256	2 x M32 x 1.5
	1LA9 131			490.5	167	132	256	2 x M32 x 1.5
	1LA9 133		4	490.5	167	132	256	2 x M32 x 1.5
	1LA9 134			490.5	167	132	256	2 x M32 x 1.5
	1MA6			453	194	132	256	2 x M32 x 1.5
	1MA7			452.5	167	132	256	2 x M32 x 1.5
160 M/ 160 L	1LA6		588	226	160	300	2 x M40 x 1.5	
	1LA7		588	197	160	300	2 x M40 x 1.5	
	1LA9		588	197	160	300	2 x M40 x 1.5	
	1LA9 166		628	197	160	300	2 x M40 x 1.5	
	1MA6		588	226	160	300	2 x M40 x 1.5	
	1MA7		588	197	160	300	2 x M40 x 1.5	
180 M/ 180 L	1MA7 166-4		628	197	160	300	2 x M40 x 1.5	
	1MA7 166-6		628	197	160	300	2 x M40 x 1.5	
	1MJ6		641	280	160	300	2 x M40 x 1.5 1 x M16 x 1.5	
	1LA5		712	258	180	339	2 x M40 x 1.5	
	1LA9		712	258	180	339	2 x M40 x 1.5	
	1LG4		669	262	180	339	2 x M40 x 1.5	
	1LG4 188		720	262	180	339	2 x M40 x 1.5	
	1LG6 183	2	720	262	180	339	2 x M40 x 1.5	
	1LG6 183	4	669	262	180	339	2 x M40 x 1.5	
	1LG6 186	4, 6, 8	720	262	180	339	2 x M40 x 1.5	
200 L	1MJ6		715	306	180	339	2 x M40 x 1.5	
	1LA5		769.5	305	200	388	2 x M50 x 1.5	
	1LA9		768.5	305	200	388	2 x M50 x 1.5	
	1LG4		720	300	200	378	2 x M50 x 1.5	
	1LG4 208	2, 6	777	300	200	378	2 x M50 x 1.5	
	1LG6 206		720	300	200	378	2 x M50 x 1.5	
	1LG6 207	2, 6	777	300	200	378	2 x M50 x 1.5	
	1LG6 207	4, 8	720	300	200	378	2 x M50 x 1.5	
1MJ6		771.5	349	200	398	2 x M50 x 1.5		

# IEC Squirrel-Cage Motors

## Explosion-proof motors

### Dimensions

#### Overview (continued)

#### Overall dimensions

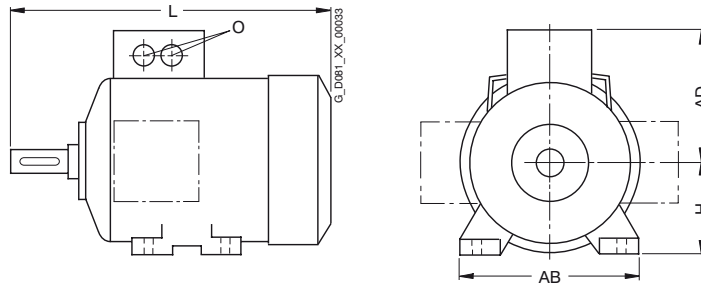

Frame size	Type	Number of poles	Dimensions				
			L	AD	H	AB	O
225 S/	1LA5	2	806	305	225	426	2 x M50 x 1.5
225 M	1LA5		776	305	225	426	2 x M50 x 1.5
	1LG4	2	789	325	225	436	2 x M50 x 1.5
	1LG4 223		759	325	225	436	2 x M50 x 1.5
	1LG4 228	2	819	325	225	436	2 x M50 x 1.5
	1LG4 228	4, 6, 8	849	325	225	436	2 x M50 x 1.5
	1LG6 220	4, 8	789	325	225	436	2 x M50 x 1.5
	1LG6 223	2	819	325	225	436	2 x M50 x 1.5
	1LG6 223	4, 6, 8	849	325	225	436	2 x M50 x 1.5
	1LG6 228	2	869	325	225	436	2 x M50 x 1.5
	1LG6 228	4, 6	899	325	225	436	2 x M50 x 1.5
	1MJ7	2	839	377	225	436	2 x M50 x 1.5
	1MJ7 223		809	377	225	436	2 x M50 x 1.5
250 M	1LG4	4	887	392	250	490	2 x M63 x 1.5
	1LG4 258		957	392	250	490	2 x M63 x 1.5
	1LG6 253	2, 6, 8	887	392	250	490	2 x M63 x 1.5
	1LG6 253	4	957	392	250	490	2 x M63 x 1.5
	1LG6 258	2, 4, 6	957	392	250	490	2 x M63 x 1.5
	1MJ7	2	930	466	250	506	2 x M63 x 1.5
	1MJ7		930	466	250	506	2 x M63 x 1.5
280 S/	1LG4	2, 4	960	432	280	540	2 x M63 x 1.5
280 M	1LG4 288		1070	432	280	540	2 x M63 x 1.5
	1LG6 280	2, 4, 6, 8	960	432	280	540	2 x M63 x 1.5
	1LG6 283	2, 4	1070	432	280	540	2 x M63 x 1.5
	1LG6 283	6, 8	960	432	280	540	2 x M63 x 1.5
	1LG6 288	2, 4, 6	1070	432	280	540	2 x M63 x 1.5
	1MJ7	2	1010	491	280	557	2 x M63 x 1.5
	1MJ7		1010	491	280	557	2 x M63 x 1.5
315 S/	1LG4	4, 6, 8	1072	500	315	610	2 x M63 x 1.5
315 M/	1LG4 310		1102	500	315	610	2 x M63 x 1.5
315 L	1LG4 313	4, 6, 8	1102	500	315	610	2 x M63 x 1.5
	1LG4 316	2	1232	500	315	610	2 x M63 x 1.5
	1LG4 316	4, 6, 8	1262	500	315	610	2 x M63 x 1.5
	1LG4 317	2	1232	500	315	610	2 x M63 x 1.5
	1LG4 317	4, 6, 8	1262	500	315	610	2 x M63 x 1.5
	1LG4 318	8	1262	500	315	610	2 x M63 x 1.5
	1LG4 318	6	1402	500	315	610	2 x M63 x 1.5
	1LG6 310	2	1072	500	315	610	2 x M63 x 1.5
	1LG6 310	4, 6, 8	1102	500	315	610	2 x M63 x 1.5
	1LG6 313	2	1232	500	315	610	2 x M63 x 1.5
	1LG6 313	4, 6	1262	500	315	610	2 x M63 x 1.5
	1LG6 313	8	1102	500	315	610	2 x M63 x 1.5
	1LG6 316	2	1232	500	315	610	2 x M63 x 1.5
	1LG6 316	4, 6, 8	1262	500	315	610	2 x M63 x 1.5
	1LG6 317	2	1372	500	315	610	2 x M63 x 1.5
	1LG6 317	4, 6	1402	500	315	610	2 x M63 x 1.5
	1LG6 317	8	1262	500	315	610	2 x M63 x 1.5
	1LG6 318	2	1372	651	315	610	2 x M63 x 1.5
	1LG6 318	4	1402	651	315	610	2 x M63 x 1.5
	1LG6 318	6, 8	1402	500	315	610	2 x M63 x 1.5
	1MJ7	2	1114	558	315	628	2 x M63 x 1.5
	1MJ7	4, 6, 8	1140	558	315	628	2 x M63 x 1.5

**Overview** (continued)

**Notes on the dimensions**

■ Dimension designations according to DIN EN 50347 and IEC 60072.

■ Fits

The shaft extensions specified in the dimension tables (DIN 748) and centering spigot diameters (DIN EN 50347) are machined with the following fits:

Dimension designation	ISO fit DIN ISO 286-2	
D, DA	up to 30	j6
	over 30 to 50	k6
	over 50	m6
N	up to 250	j6
	over 250	h6
F, FA		h9
K		H17
S	flange (FF)	H17

The drilled holes of couplings and belt pulleys should have an ISO fit of at least H7.

■ Dimension tolerances

For the following dimensions, the admissible deviations are given below:

Dimension designation	Dimension	Admissible deviation
H	up to 250	- 0.5
	over 250	- 1.0
E, EA		- 0.5

Keyways and feather keyways (dimensions GA, GC, F and FA) are made in compliance with DIN 6885 Part 1.

■ All dimensions are specified in mm.

**More information**
**Dimension sheet generator**

(part of the SD configurator)

A dimension drawing can be created in the SD configurator for every configurable motor. A dimension drawing can be requested for every other motor.

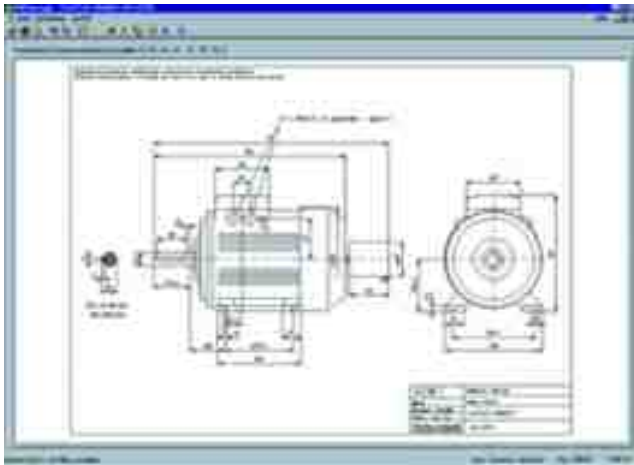

When a complete Order No. is entered with or without order codes, a dimension drawing can be called up under the "Documentation" tab.

These dimension drawings can be presented in different views and sections and printed.

The corresponding dimension sheets can be exported, saved and processed further in DXF format (interchange/import format for CAD systems) or as bitmap graphics.

The SD configurator has been integrated into the electronic Catalog CA 01 as a selection aid (for more information, see catalog part 11 "Appendix", "Selection tool SD-configurator").

The interactive Catalog CA 01 can be ordered from your local Siemens sales representative or on the Internet at

<http://www.siemens.com/automation/CA01>

At this address, you will also find links to Tips & Tricks and to downloads for function or content updates.

Order number for CA 01 10/2008, English International:  
DVD: E86060-D4001-A510-C7-7600

# IEC Squirrel-Cage Motors

## Explosion-proof motors

### Dimensions

#### Dimensional drawings

Aluminum series 1MA7, frame sizes 63 M to 160 L

#### Type of construction IM B3

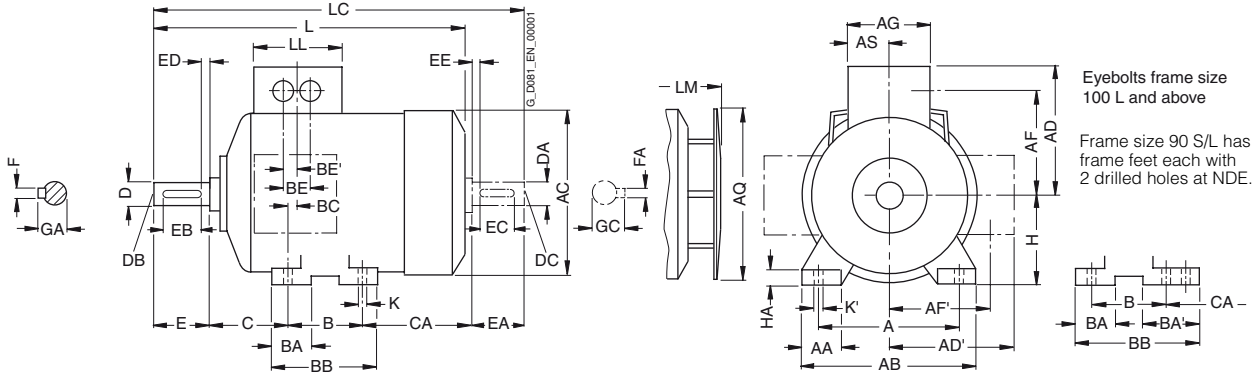

Eyebolts frame size 100 L and above  
 Frame size 90 S/L has frame feet each with 2 drilled holes at NDE.

#### Types of construction IM B5 and IM V1

For flange dimensions, see Page 4/152 (Z = the number of retaining holes)

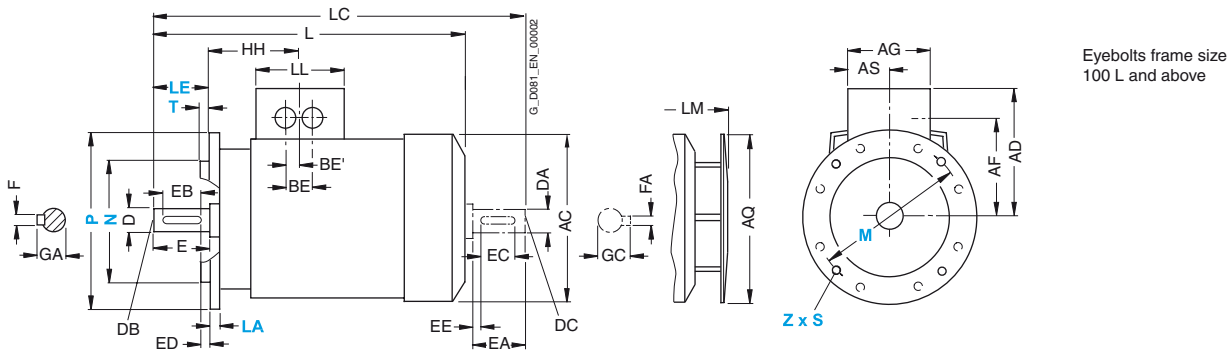

Eyebolts frame size 100 L and above

For motor			Dimension designation acc. to IEC																					
Frame size	Type	Number of poles	A	AA	AB	AC <sup>1)</sup>	AD	AD'	AF	AF'	AG	AQ	AS	B*	BA	BA'	BB	BC	BE	BE'	C	CA*	H	HA
63 M	1MA7 060 1MA7 063	2, 4, 6	100	27	120	124	135	101	95	78	120	124	60	80	28	-	96	52.5	32	16	40	66	63	7
71 M	1MA7 070 1MA7 073	2, 4, 6, 8	112	27	132	145	145	111	105	88	120	124	60	90	27	-	106	41.5	32	16	45	83	71	7
80 M	1MA7 080 1MA7 083	2, 4, 6, 8	125	30.5	150	163	154	154	114	114	120	124	60	100	32	-	118	36	32	16	50	94 134 <sup>2)</sup>	80	8
90 S 90 L	1MA7 090 1MA7 096	2, 4, 6, 8	140	30.5	165	180	162	162	122	122	120	170	60	100 125	33	54	143	46	32	16	56	143 118	90	10
100 L	1MA7 106 1MA7 107	2, 4, 6, 8 4, 8	160	42	196	203	135	163	78	123	120	170	60	140	47	-	176	39	42	21	63	125	100	12
112 M	1MA7 113	2, 4, 6, 8	190	46	226	227	148	176	91	136	120	170	60	140	47	-	176	32	42	21	70	141	112	12
132 S	1MA7 130 1MA7 131	2, 4, 6, 8 2	216	53	256	267	167	194	107	154	140	250	70	140	49	-	180	39	42	21	89	162.5	132	15
132 M	1MA7 133 1MA7 134	4, 6, 8 6	216	53	256	267	167	194	107	154	140	250	70	178	49	-	218	39	42	21	89	124.5 162.5 <sup>3)</sup>	132	15
160 M	1MA7 163 1MA7 164	2, 4, 6, 8 2, 8	254	60	300	320	197	226	127	183	165	250	82.5	210	57	-	256	52.5	54	27	108	183	160	18
160 L	1MA7 166	2, 4, 6, 8	254	60	300	320	197	226	127	183	165	250	82.5	254	57	-	300	52.5	54	27	108	139 179 <sup>4)</sup>	160	18

\* This dimension is assigned in DIN EN 50347 to the frame size listed.

1) Measured across the bolt heads.

2) For 1MA7 083-6.

3) For 1MA7 133-4.

4) For 1MA7 166-4 and 1MA7 166-6.

### Dimensional drawings

#### Aluminum series 1MA7, frame sizes 63 M to 160 L

##### Type of construction IM B35

For flange dimensions, see Page 4/152 (Z = the number of retaining holes)

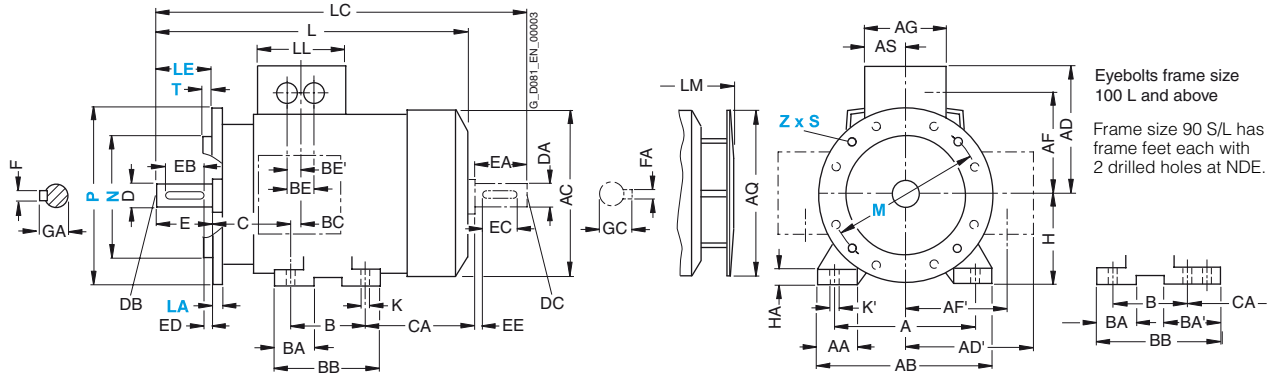

##### Type of construction IM B14

For flange dimensions, see Page 4/152 (Z = the number of retaining holes)

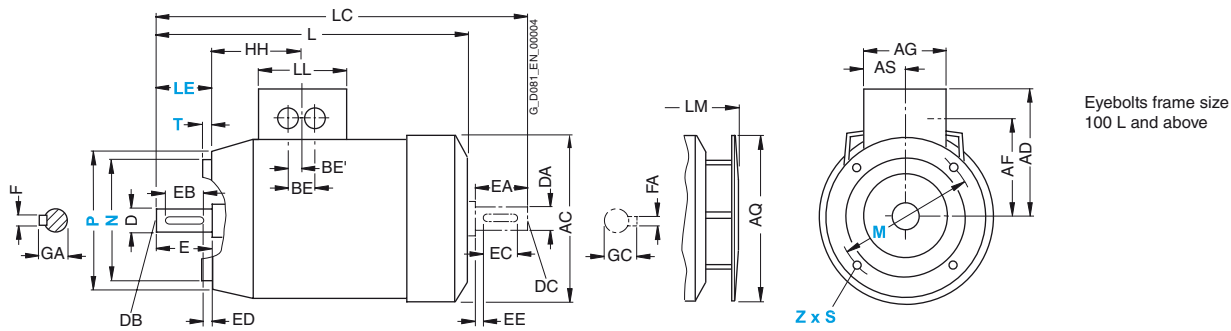

For motor		Number of poles	Dimension designation acc. to IEC					DE shaft extension					NDE shaft extension										
Frame size	Type		HH	K	K'	L	LC	LL	LM	D	DB	E	EB	ED	F	GA	DA	DC	EA	EC	EE	FA	GC
63 M	1MA7 060 1MA7 063	2, 4, 6	92.5	7	10	202.5 <sup>1)</sup>	232 <sup>1)</sup>	120	231.5 <sup>1)</sup>	11	M4	23	16	3.5	4	12.5	11	M4	23	16	3.5	4	12.5
71 M	1MA7 070 1MA7 073	2, 4, 6, 8	86.5	7	10	240	278	120	268	14	M5	30	22	4	5	16	14	M5	30	22	4	5	16
80 M	1MA7 080 1MA7 083	2, 4, 6, 8	86	9.5	13.5	273.5 308.5 <sup>2)</sup>	324 364	120	299.5 334.5 <sup>2)</sup>	19	M6	40	32	4	6	21.5	19	M6	40	32	4	6	21.5
90 S 90 L	1MA7 090 1MA7 096	2, 4, 6, 8	101.5	10	14	331	389	120	382.5	24	M8	50	40	5	8	27	19	M6	40	32	4	6	21.5
100 L	1MA7 106 1MA7 107	2, 4, 6, 8 4, 8	102	12	16	372	438	120	423.5	28	M10	60	50	5	8	31	24	M8	50	40	5	8	27
112 M	1MA7 113	2, 4, 6, 8	102	12	16	393	461	120	444.5	28	M10	60	50	5	8	31	24	M8	50	40	5	8	27
132 S	1MA7 130 1MA7 131 2	2, 4, 6, 8	128	12	16	452.5 <sup>3)</sup>	551.5	140	505 <sup>3)</sup>	38	M12	80	70	5	10	41	38	M12	80	70	5	10	41
132 M	1MA7 133 1MA7 134	4, 6, 8 6	128	12	16	452.5 <sup>3)</sup> 490.5 <sup>4)</sup>	551.5 589.5 <sup>4)</sup>	140	505 <sup>3)</sup> 543 <sup>4)</sup>	38	M12	80	70	5	10	41	38	M12	80	70	5	10	41
160 M	1MA7 163 1MA7 164	2, 4, 6, 8 2, 8	160.5	15	19	588	721	165	640.5	42	M16	110	90	10	12	45	42	M16	110	90	10	12	45
160 L	1MA7 166	2, 4, 6, 8	160.5	15	19	588 628 <sup>5)</sup>	721 761 <sup>5)</sup>	165	640.5 680.5 <sup>5)</sup>	42	M16	110	90	10	12	45	42	M16	110	90	10	12	45

1) For 1MA7 063 with type of construction code 1 (B5, IM V1 without protective cover, IM V3) the dimensions L, LC and LM are 26 mm longer.  
 2) For 1MA7 083-6.  
 3) In a low-noise version, the dimension L is 8 mm greater and the dimension LM is 11.5 mm greater.

4) For 1MA7 133-4.  
 5) For 1MA7 166-4 and 1MA7 166-6.

# IEC Squirrel-Cage Motors

## Explosion-proof motors

### Dimensions

#### Dimensional drawings

Cast-iron series 1MA6, frame sizes 100 L to 160 L

#### Type of construction IM B3

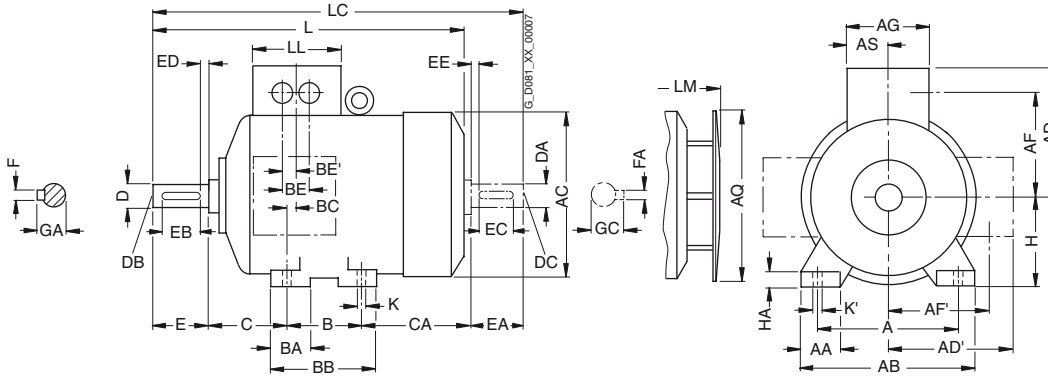

#### Types of construction IM B5 and IM V1

For flange dimensions, see Page 4/152 (Z = the number of retaining holes)

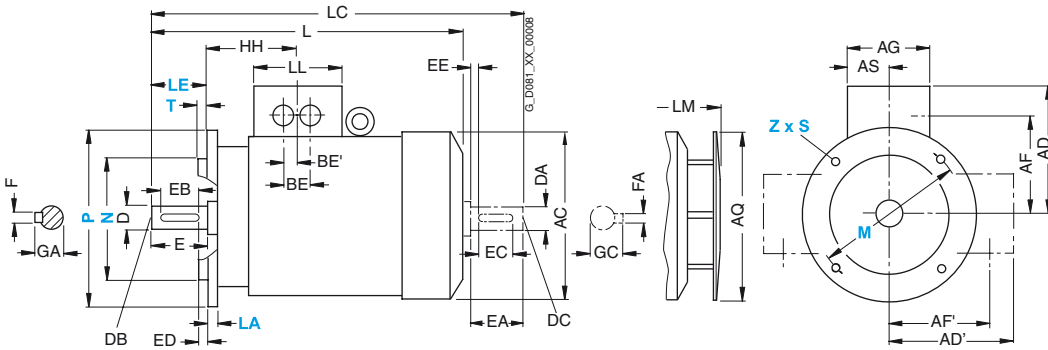

For motor			Dimension designation acc. to IEC																				
Frame size	Type	Number of poles	A	AA	AB	AC <sup>1)</sup>	AD	AD'	AF	AF'	AG	AQ	AS	B	BA	BB	BC	BE	BE'	C	CA	H	HA
100 L	1MA6 106	2, 4, 6, 8	160	40	196	201	164	164	124	124	121	170	60.5	140	46	180	42	44	22	63	125	100	12
	1MA6 107	4, 8																					
112 M	1MA6 113	2, 4, 6, 8	190	42.5	226	225.5	178	178	138	138	121	170	60.5	140	46	180	34	44	22	70	141	112	15
132 S	1MA6 130	2, 4, 6, 8	216	50	256	265	194	194	154	154	141	250	70.5	140	47	180	42	44	22	89	162.5	132	17
	1MA6 131	2																					
132 M	1MA6 133	4, 6, 8	216	50	256	265	194	194	154	154	141	250	70.5	178	49	218	42	44	22	89	124.5	132	17
	1MA6 134	6																					
160 M	1MA6 163	2, 4, 6, 8	254	60	300	320	226	226	183	183	166	250	83	210	63	256	52	54	27	108	183	160	18
	1MA6 164	2, 8																					
160 L	1MA6 166	2, 4, 6, 8	254	60	300	320	226	226	183	183	166	250	83	254	63	300	52	54	27	108	139	160	18

<sup>1)</sup> Measured across the bolt heads.



## Dimensional drawings

Cast-iron series 1MA6, frame sizes 100 L to 160 L

### Type of construction IM B35

For flange dimensions, see Page 4/152 (Z = the number of retaining holes)

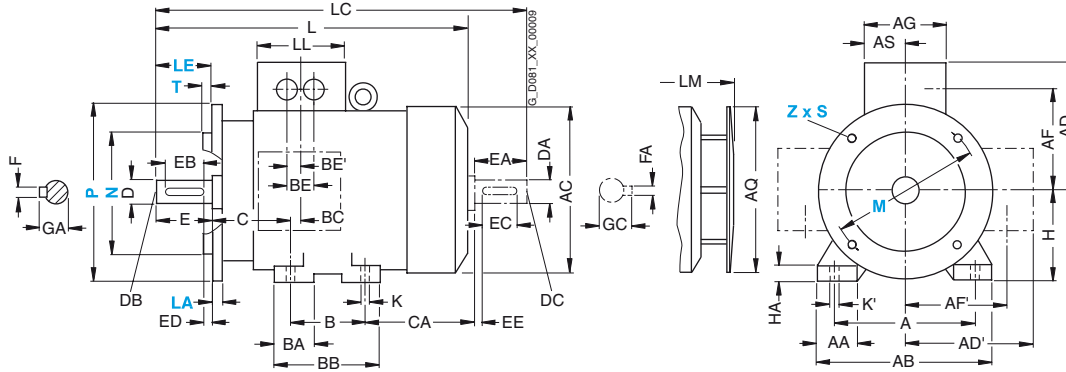

### Type of construction IM B14

For flange dimensions, see Page 4/152 (Z = the number of retaining holes)

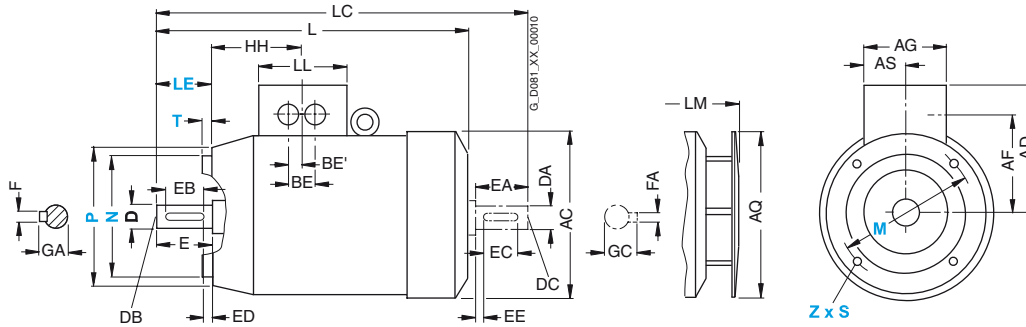

For motor Frame size	Type	Number of poles	Dimension designation acc. to IEC							DE shaft extension					NDE shaft extension								
			HH	K	K'	L	LC	LL	LM	D	DB	E	EB	ED	F	GA	DA	DC	EA	EC	EE	FA	GC
100 L	1MA6 106 1MA6 107	2, 4, 6, 8 4, 8	104.5	12	16	372	438	121	423.5	28	M10	60	50	5	8	31	24	M8	50	40	5	8	27
112 M	1MA6 113	2, 4, 6, 8	104.5	12	16	393	461	121	444.5	28	M10	60	50	5	8	31	24	M8	50	40	5	8	27
132 S	1MA6 130 1MA6 131	2, 4, 6, 8 2	130.5	12	16	453.5	551.5	141	506	38	M12	80	70	5	10	41	38	M12	80	70	5	10	41
132 M	1MA6 133 1MA6 134	4, 6, 8 6	130.5	12	16	453.5	551.5	141	506	38	M12	80	70	5	10	41	38	M12	80	70	5	10	41
160 M	1MA6 163 1MA6 164	2, 4, 6, 8 2, 8	160	14.5	18	588	721	166	640.5	42	M16	110	90	10	12	45	42	M16	110	90	10	12	45
160 L	1MA6 166	2, 4, 6, 8	160	14.5	18	588	721	166	640.5	42	M16	110	90	10	12	45	42	M16	110	90	10	12	45

# IEC Squirrel-Cage Motors

## Explosion-proof motors

### Dimensions

#### Dimensional drawings

Cast-iron series 1MA6, frame sizes 180 M to 315 L

#### Type of construction IM B3

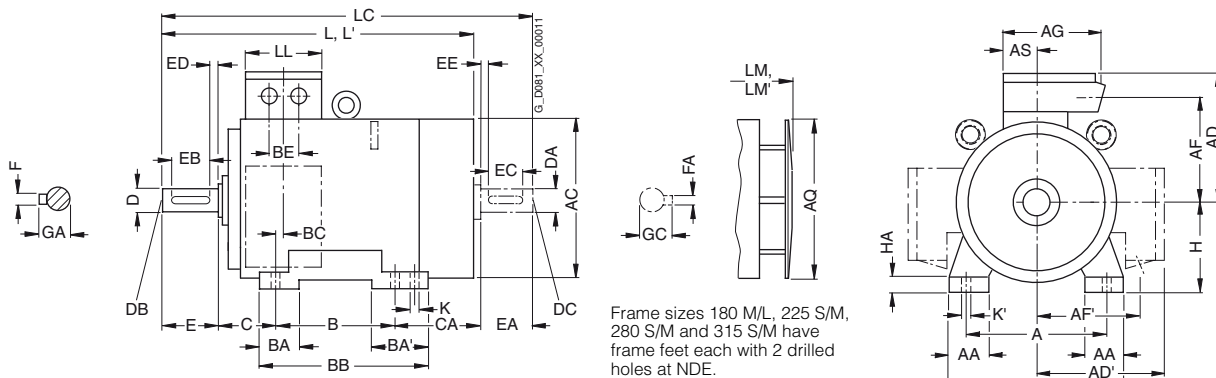

#### Types of construction IM B5 and IM V1

For flange dimensions, see Page 4/152 (Z = the number of retaining holes)

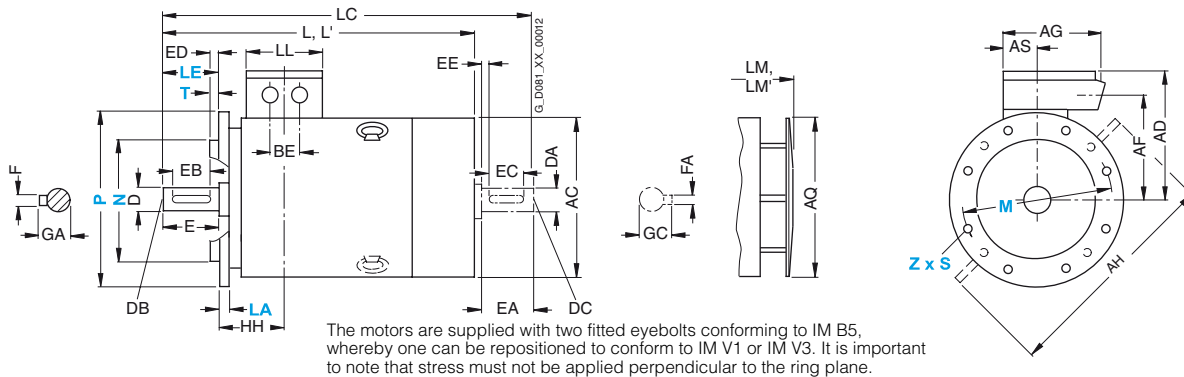

For motor			Dimension designation acc. to IEC																					
Frame size	Type	Number of poles	A	AA	AB	AC <sup>1)</sup>	AD	AD'	AF	AF'	AG	AH	AQ	AS	B*	BA	BA'	BB	BC	BE	C	CA*	H	HA
180 M	1MA6 183	2	279	65	344	375	274	274	227	227	220	470	340	82	241	70	108	319	35	75	121	259	180	26
		4																						
180 L	1MA6 186	4, 6, 8	279	65	344	375	274	274	227	227	220	470	340	82	279	70	108	319	35	75	121	221	180	26
200 L	1MA6 206	2	318	80	398	402	308	308	248	248	262	530	340	99	305	85	85	355	42	85	133	239	200	34
		6																						
	1MA6 207	2	318	80	398	402	308	308	248	248	262	530	340	99	305	85	85	355	42	85	133	239	200	34
		4, 6, 8																						
225 S	1MA6 220	4, 8	356	80	436	442	339	339	269	269	264	580	425	100	286	85	110	361	25	85	149	269	225	34
225 M	1MA6 223	2	356	80	436	442	339	339	269	269	264	580	425	100	311	85	110	361	25	85	149	244	225	34
		4, 6, 8																						
250 M	1MA6 253	2	406	100	506	505	427	427	333	333	338	645	470	120	349	100	100	409	39	95	168	283	250	42
		4, 6, 8																						
280 S	1MA6 280	2	457	100	557	555	452	452	358	358	338	700	525	120	368	100	151	471	30	95	190	317	280	42
		4, 6, 8																						
280 M	1MA6 283	2	457	100	557	555	452	452	358	358	338	700	525	120	419	100	151	471	30	95	190	366	280	42
		4, 6, 8																						
315 S	1MA6 310	2	508	120	628	620	515	515	395	395	405	805	590	134	406	125	171	527	32	90	216	358	315	52
		4, 6, 8																						
315 M	1MA6 313	2	508	120	628	620	515	515	395	395	405	805	590	134	457	125	171	527	32	90	216	307	315	52
		4, 6, 8																						
315 L	1MA6 316	2	508	120	628	620	515	515	395	395	405	805	590	134	508	120	120	578	32	90	216	396	315	52
		4, 6, 8																						
		6, 8																						

■ Dimensions for 9-terminal connection box can be supplied on request.

<sup>1)</sup> Measured across the bolt heads.

\* This dimension is assigned in DIN EN 50347 to the frame size listed.

# IEC Squirrel-Cage Motors

## Explosion-proof motors

### Dimensions

#### Dimensional drawings

Cast-iron series 1MA6, frame sizes 180 M to 315 L

#### Type of construction IM B35

For flange dimensions, see Page 4/152 (Z = the number of retaining holes)

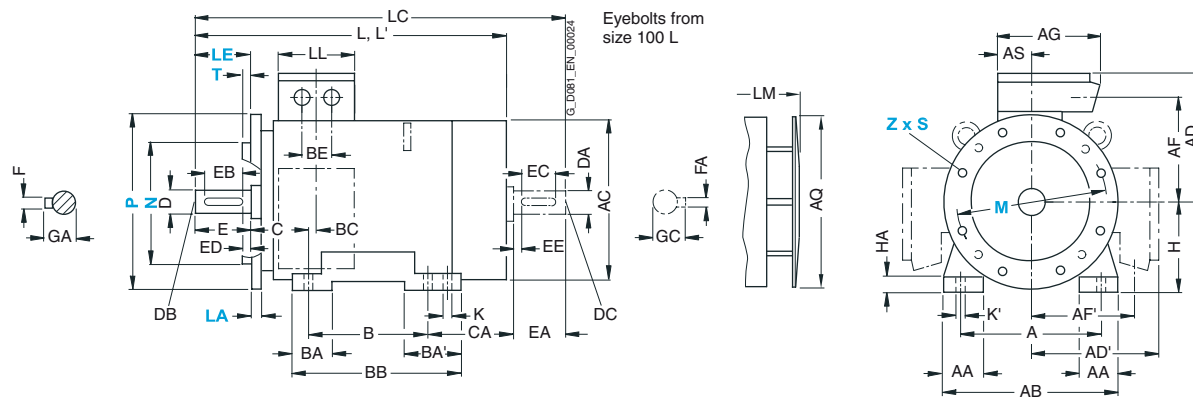

For motor		Dimension designation acc. to IEC										DE shaft extension					NDE shaft extension								
Frame size	Type	Number of poles	HH	K	K'	L	L <sup>1)</sup>	LC <sup>2)</sup>	LL	LM	LM <sup>1)</sup>	D	DB	E	EB	ED	F	GA	DA	DC	EA	EC	EE	FA	GC
180 M	1MA6 183	2	156	15	20	715	770	841	164	796.5	855	48	M16	110	100	5	14	51.5	48	M16	110	100	5	14	51.5
		4																							
180 L	1MA6 186	4, 6, 8	156	15	20	715	—	841	164	796.5	—	48	M16	110	100	5	14	51.5	48	M16	110	100	5	14	51.5
200 L	1MA6 206	2	175	19	25		819.5	897	197	853	901	55	M20	110	100	5	16	59	48	M16	110	100	5	14	51.5
		6				771.5	—												55	M20					16 59
	1MA6 207	2	175	19	25	771.5	819.5	897	197	853	901	55	M20	110	100	5	16	59	48	M16	110	100	5	14	51.5
		4, 6, 8																	55	M20					16 59
225 S	1MA6 220	4, 8	174	19	25	839	—	954	200	935	—	60	M20	140	125	10	18	64	55	M20	110	100	10	16	59
225 M	1MA6 223	2	174	19	25	809	855	924	200	909	955	55	M20	110	100	5	16	59	48	M16	110	100	5	14	51.5
		4, 6, 8				839	—	954		935	—	60		140	125	10	18	64	55	M20		100	10	16	59
250 M	1MA6 253	2	207	24	30	935	1010	1050	234	1035	1110	60	M20	140	125	10	18	64	55	M20	110	100	5	16	59
		4, 6, 8					—	1080			—	65						69	60		140	125	18	64	64
280 S	1MA6 280	2	220	24	30	1010	1080	1155	234	1120	1230	65	M20	140	125	10	18	69	60	M20	140	125	10	18	64
		4, 6, 8					—				75						20	79.5	65					69	69
280 M	1MA6 283	2	220	24	30	1010	1080	1155	234	1120	1230	65	M20	140	125	10	18	69	60	M20	140	125	10	18	64
		4, 6, 8					—				75						20	79.5	65					64	69
315 S	1MA6 310	2	248	28	35	1114	1185	1260	266	1224	1295	65	M20	140	125	10	18	69	60	M20	140	125	10	18	64
		4, 6, 8				1144	—	1290		1254	—	80		170	140		22	85	70					20	74.5
315 M	1MA6 313	2	248	28	35	1114	1185	1260	266	1224	1295	65	M20	140	125	10	18	69	60	M20	140	125	10	18	64
		4, 6, 8				1144	—	1290		1254	—	80		170	140		22	85	70					20	74.5
315 L	1MA6 316	2	248	28	35	1254	1325	1400	266	1364	1435	65	M20	140	125	10	18	69	60	M20	140	125	10	18	64
	1MA6 317	4, 6, 8				1284	—	1430		1394	—	80		170	140		22	85	70					20	74.5
	1MA6 318	6, 8				1284	—	1430		1394	—	80		170	140		22	85	70					20	74.5

1) For version with low-noise fan.

2) In the low-noise version, a second shaft extension is not possible.

# IEC Squirrel-Cage Motors

## Explosion-proof motors

### Dimensions

#### Dimensional drawings

Cast-iron series 1MJ6, frame sizes 71 M to 160 L

#### Type of construction IM B3

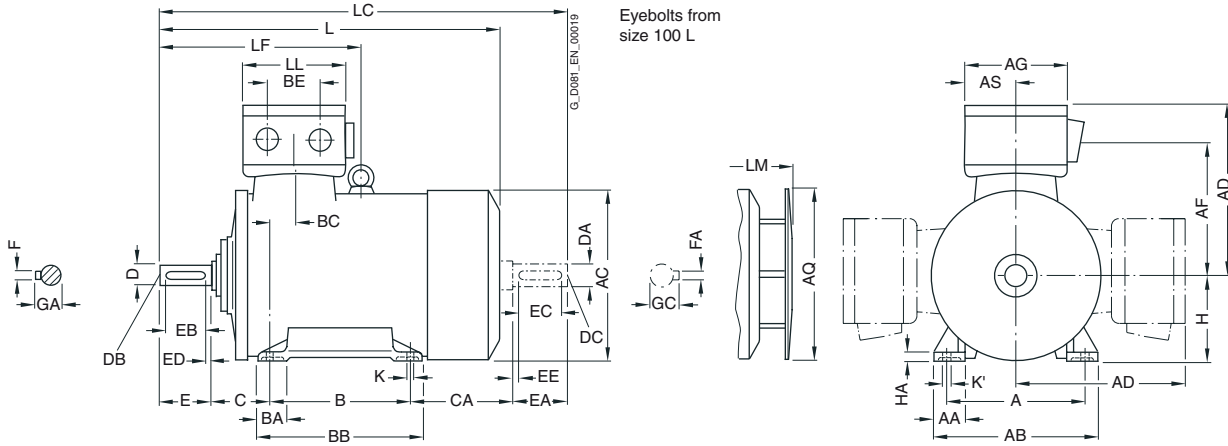

#### Types of construction IM B5 and IM V1

For flange dimensions, see Page 4/152 (Z = the number of retaining holes)

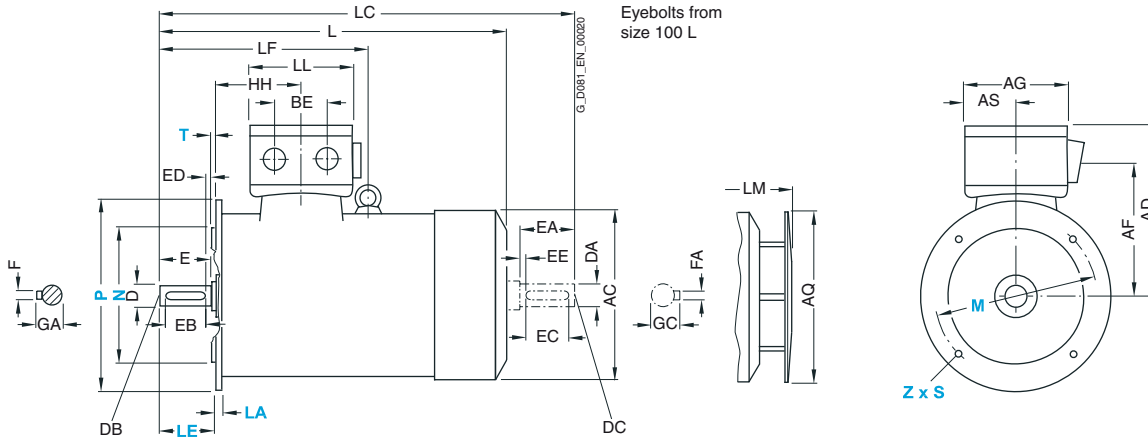

For motor Frame size	Type	Number of poles	Dimension designation acc. to IEC																					
			A	AA	AB	AC <sup>1)</sup>	AD	AF	AG	AQ	AS	B	BA	BB	BC	BE	C	CA	H	HA	HH	K	K'	L
71 M	1MJ6 070	2, 4	112	34	140	148.5	201 <sup>2)</sup>	162	152	124	71	90	30	110	58	54	45	144	71	8	103	7	10	299
	1MJ6 073	2, 4, 6																						
80 M	1MJ6 080	2, 4, 6	125	36	160	165.5	209 <sup>2)</sup>	170	152	125	71	100	35	125	44	54	50	156	80	10	93.5	9.5	13.5	336
	1MJ6 083	2, 4, 6																						
90 L	1MJ6 096	2, 4, 6, 8	140	37	168	183	218	177	162	170	81	125	35	156	54	54	56	177	90	13	109.5	10	14	383
	1MJ6 097	2, 4, 6, 8																						
100 L	1MJ6 106	2, 4, 6, 8	160	45	196	202.5	223	182	162	170	81	140	45	176	50	54	63	185	100	14	112.5	12	16	426
	1MJ6 107	4, 8																						
112 M	1MJ6 113	2, 4, 6, 8	190	50	226	228.5	238	197	162	170	81	140	45	176	52	54	70	180	112	15	121.5	12	16	428
132 S	1MJ6 130	2, 4, 6, 8	216	53	256	267.5	258	217	162	250	81	140	49	180	55	54	89	228	132	17	144	12	16	515
	1MJ6 131	2																						
132 M	1MJ6 133	4, 6, 8	216	53	256	267.5	258	217	162	250	81	178	49	218	55	54	89	190	132	17	144	12	16	515
	1MJ6 134	6																						
160 M	1MJ6 163	2, 4, 6, 8	254	60	300	323	280	239	162	250	81	210	57	256	40	54	108	238	160	20	148	15	19	641
	1MJ6 164	2, 8																						
160 L	1MJ6 166	2, 4, 6, 8	254	60	300	323	314	246	216	250	95	254	57	300	40	96	108	194	160	20	148	15	19	641

1) Measured across the bolt heads.

2) K09 and K10 frame size 90 and above.

#### Dimensional drawings

##### Cast-iron series 1MJ6, frame sizes 71 M to 160 L

##### Type of construction IM B35

For flange dimensions, see Page 4/152 (Z = the number of retaining holes)

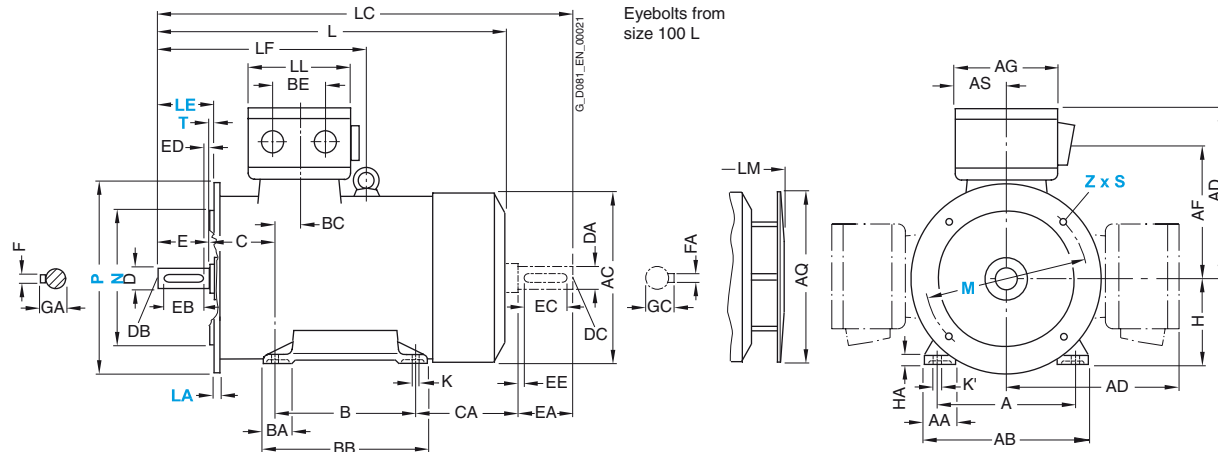

##### Type of construction IM B14 – only for frame sizes 71 M to 90 L

For flange dimensions, see Page 4/152 (Z = the number of retaining holes)

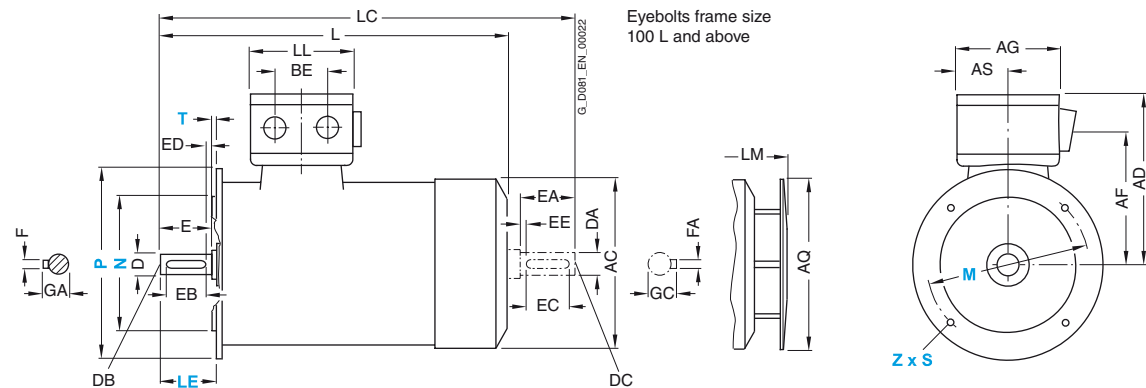

For motor Frame size	Type	Number of poles	Dimension designation acc. to IEC										DE shaft extension							NDE shaft extension						
			LC	LF	LL	LM	D	DB	E	EB	ED	F	GA	DA	DC	EA	EC	EE	FA	GC						
71 M	1MJ6 070	2, 4	339	-	132	327	14	M5	30	22	4	5	16	14	M5	30	22	4	5	16						
	1MJ6 073	2, 4, 6																								
80 M	1MJ6 080	2, 4, 6	386	-	132	362	19	M6	40	32	4	6	21.5	19	M6	40	32	4	6	21.5						
	1MJ6 083	2, 4, 6																								
90 L	1MJ6 096	2, 4, 6, 8	458	-	162	434.5	24	M8	50	40	5	8	27	24	M8	50	40	5	8	27						
	1MJ6 097	2, 4, 6, 8																								
100 L	1MJ6 106	2, 4, 6, 8	508	-	162	477.5	28	M10	60	50	5	8	31	28	M10	60	50	5	8	31						
	1MJ6 107	4, 8																								
112 M	1MJ6 113	2, 4, 6, 8	510	-	162	479.5	28	M10	60	50	5	8	31	28	M10	60	50	5	8	31						
132 S	1MJ6 130	2, 4, 6, 8	617	-	162	567.5	38	M12	80	70	5	10	41	38	M12	80	70	5	10	41						
	1MJ6 131	2																								
132 M	1MJ6 133	4, 6, 8	617	-	162	567.5	38	M12	80	70	5	10	41	38	M12	80	70	5	10	41						
	1MJ6 134	6																								
160 M	1MJ6 163	2, 4, 6, 8	776	383	162	693.5	42	M16	110	90	10	12	45	42	M16	110	90	10	12	45						
	1MJ6 164	2, 8																								
160 L	1MJ6 166	2, 4, 6, 8	776	383	190	693.5	42	M16	110	90	10	12	45	42	M16	110	90	10	12	45						

# IEC Squirrel-Cage Motors

## Explosion-proof motors

### Dimensions

#### Dimensional drawings

Cast-iron series 1MJ6 and 1MJ7, frame sizes 180 M to 315 M

Type of construction IM B3

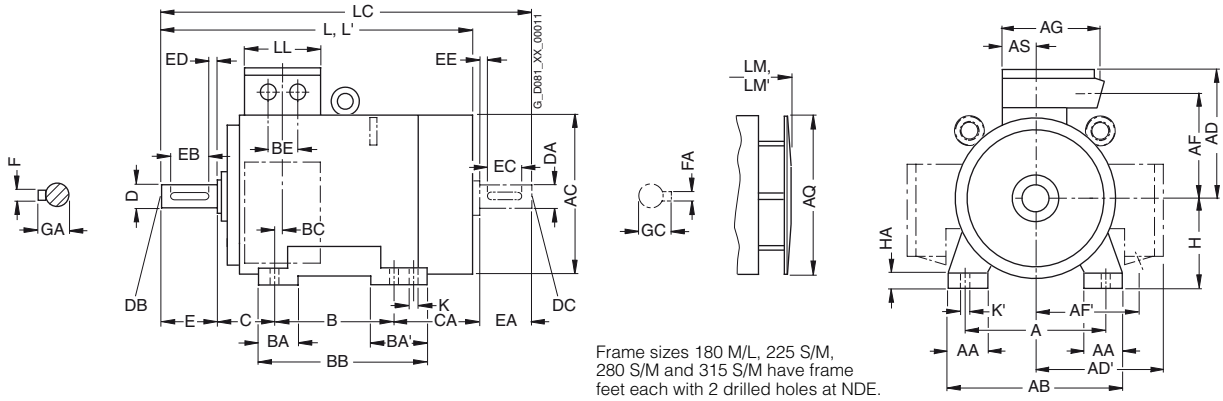

4

Types of construction IM B5 and IM V1

For flange dimensions, see Page 4/152 (Z = the number of retaining holes)

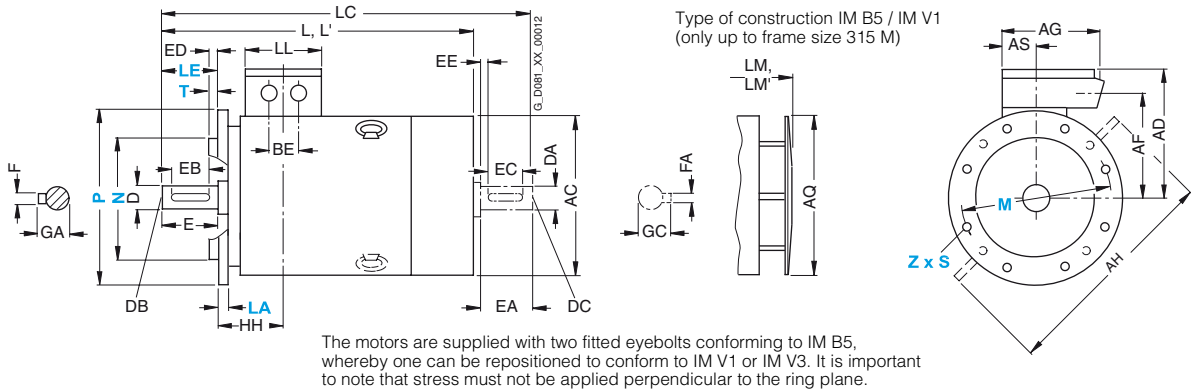

For motor			Dimension designation acc. to IEC																						
Frame size	Type	Number of poles	A	AA	AB	AC <sup>1)</sup>	AD	AD'	AF	AF'	AG	AH	AQ	AS	B*	BA	BA'	BB	BC	BE	C	CA*	H	HH	HA
180 M	1MJ6 183	2, 4	279	65	344	375	306	306	259	259	220	470	340	82	241	70	108	319	35	75	121	259	180	156	26
180 L	1MJ6 186	4, 6, 8	279	65	344	375	306	306	259	259	220	470	340	82	279	70	108	319	35	75	121	221	180	156	26
200 L	1MJ6 206	2	318	80	398	415	349	349	289	289	262	530	340	98.5	305	85	85	355	42	85	133	239	200	175	34
	1MJ6 207	2	318	80	398	415	349	349	289	289	262	530	340	98.5	305	85	85	355	42	85	133	239	200	175	34
225 S	1MJ7 220	4, 8	356	80	436	442	377	377	315	315	262	580	425	100	286	85	110	361	25	90	149	269	225	174	34
	225 M	1MJ7 223	2	356	80	436	442	377	377	315	315	262	580	425	100	311	85	110	361	25	90	149	244	225	174
250 M	1MJ7 253	2	406	100	506	505	466	466	353	353	336	645	470	120	349	100	100	409	39	95	168	283	250	207	42
	1MJ7 280	2	457	100	557	555	491	491	395	395	336	700	525	120	368	100	151	479	30	95	190	317	280	220	42
280 M	1MJ7 283	2	457	100	557	555	491	491	395	395	336	700	525	120	419	100	151	479	30	95	190	266	280	220	42
	1MJ7 283	4, 6, 8	457	100	557	555	491	491	395	395	336	700	525	120	419	100	151	479	30	95	190	266	280	220	42
315 S	1MJ7 310	2	508	120	628	620	558	558	448	448	410	805	590	135	406	125	171	527	32	90	216	358	315	248	56
	1MJ7 313	2	508	120	628	620	558	558	448	448	410	805	590	135	457	125	171	527	32	90	216	307	315	248	56
315 M	1MJ7 313	4, 6, 8	508	120	628	620	558	558	448	448	410	805	590	135	457	125	171	527	32	90	216	307	315	248	56

\* This dimension is assigned in DIN EN 50347 to the frame size listed.  
 1) Measured across the bolt heads.

#### Dimensional drawings

Cast-iron series 1MJ6 and 1MJ7, frame sizes 180 M to 315 M

#### Type of construction IM B35

For flange dimensions, see Page 4/152 (Z = the number of retaining holes)

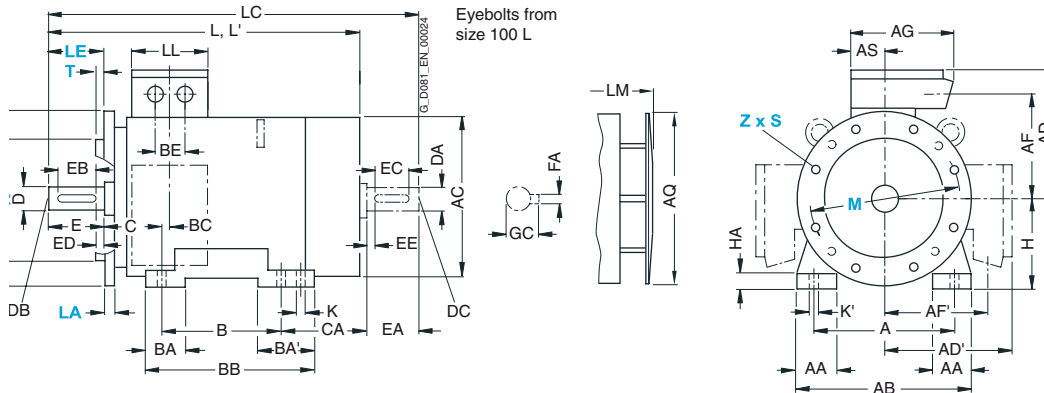

For motor		Number of poles	Dimension designation acc. to IEC										DE shaft extension						NDE shaft extension					
Frame size	Type		K	K'	L	L <sup>(1)</sup>	LC <sup>(2)</sup>	LL	LM	LM <sup>(1)</sup>	D	DB	E	EB	ED	F	GA	DA	DC	EA	EC	EE	FA	GC
180 M	1MJ6 183	2, 4	15	20	715	770	841	164	796.5	885	48	M16	110	100	5	14	51.5	48	M16	110	100	5	14	51.5
180 L	1MJ6 186	4, 6, 8	15	20	715	–	841	164	796.5	–	48	M16	110	100	5	14	51.5	48	M16	110	100	5	14	51.5
200 L	1MJ6 206	2	19	25	771.5	825	897	197	853	910	55	M20	110	100	5	16	59	48	M16	110	100	5	14	51.5
	1MJ6 207	6	–	–	–	–	–	–	–	–	–	–	–	–	–	–	–	55	M20	–	–	–	–	16 59
		2	19	25	771.5	825	897	197	853	910	55	M20	110	100	5	16	59	48	M16	110	100	5	14	51.5
		4, 6, 8	–	–	–	–	–	–	–	–	–	–	–	–	–	–	–	55	M20	–	–	–	–	16 59
225 S	1MJ7 220	4, 8	19	25	839	–	954	197	939	–	60	M20	140	125	10	18	64	55	M20	110	100	5	16	59
225 M	1MJ7 223	2	19	25	809	855	924	197	909	955	55	M20	110	100	5	16	59	48	M16	110	100	5	14	51.5
		4, 6, 8	839	–	954	939	–	60	140	125	10	18	64	55	M20	–	–	–	–	–	–	–	–	16 59
250 M	1MJ7 253	2	24	30	930	1010	1050	234	1035	1110	60	M20	140	125	10	18	64	55	M20	110	100	5	16	59
		4, 6, 8	–	–	–	–	1080	–	–	–	65	–	–	–	–	–	69	60	–	–	–	–	–	18 64
280 S	1MJ7 280	2	24	30	1010	1080	1155	234	1120	1230	65	M20	140	125	10	18	69	60	M20	140	125	10	18	64
		4, 6, 8	–	–	–	–	–	–	–	–	75	–	–	–	–	20	79.5	65	–	–	–	–	–	69
280 M	1MJ7 283	2	24	30	1010	1080	1155	234	1120	1230	65	M20	140	125	10	18	69	60	M20	140	125	10	18	64
		4, 6, 8	–	–	–	–	–	–	–	–	75	–	–	–	–	20	79.5	65	–	–	–	–	–	69
315 S	1MJ7 310	2	28	35	1114	1185	1260	266	1224	1295	65	M20	140	125	10	18	69	60	M20	140	125	10	18	64
		4, 6, 8	1140	–	1290	–	–	80	170	140	–	–	–	–	–	22	85	70	–	–	–	–	–	20 74.5
315 M	1MJ7 313	2	28	35	1114	1185	1260	266	1224	1295	65	M20	140	125	10	18	69	60	M20	140	125	10	18	64
		4, 6, 8	1140	–	1290	–	–	80	170	140	–	–	–	–	–	22	85	70	–	–	–	–	–	20 74.5

<sup>1)</sup> For version with low-noise fan.

<sup>2)</sup> In the low-noise version, a second shaft extension is not possible.

# IEC Squirrel-Cage Motors

## Explosion-proof motors

### Dimensions

#### Dimensional drawings

Aluminum series 1LA7 and 1LA5, frame sizes 56 M to 225 M

#### Type of construction IM B3

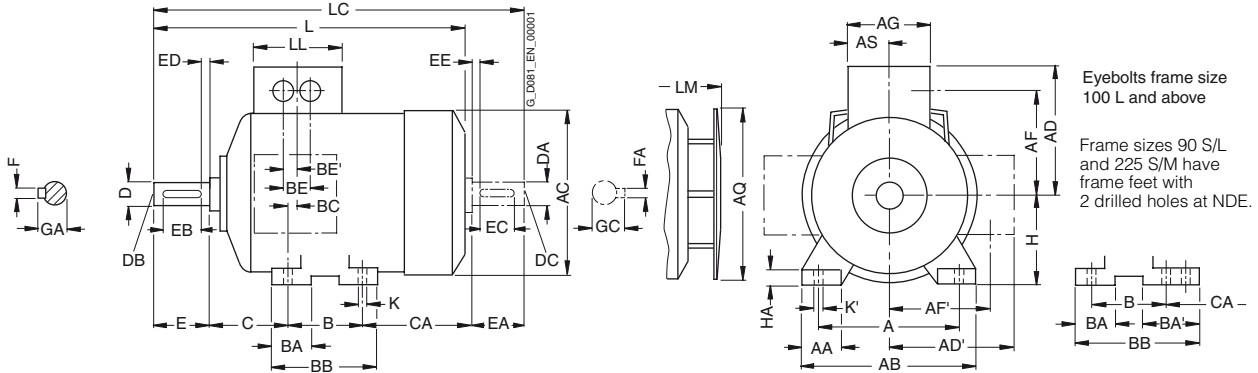

#### Types of construction IM B5 and IM V1

For flange dimensions, see Page 4/152 (Z = the number of retaining holes)

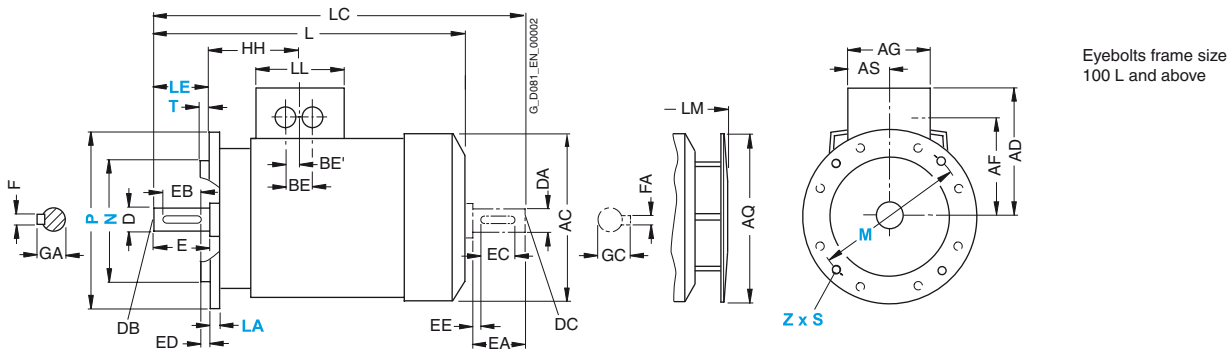

For motor		Dimension designation acc. to IEC																						
Frame size	Type	Number of poles	A	AA	AB	AC <sup>1)</sup>	AD	AD'	AF	AF'	AG	AQ	AS	B*	BA	BA'	BB	BC	BE	BE'	C	CA*	H	HA
56 M <sup>2)</sup>	1LA7 050 1LA7 053	2, 4	90	25	110	116	135	135	95	95	120	-	37	71	28	-	87	56	32	18	36	53	56	6
63 M	1LA7 060 1LA7 063	2, 4, 6	100	27	120	124	135	135	95	95	120	124	37	80	28	-	96	52	32	18	40	66	63	7
71 M	1LA7 070 1LA7 073	2, 4, 6, 8	112	27	132	145	145	145	105	105	120	124	37	90	27	-	106	41	32	18	45	83	71	7
80 M	1LA7 080 1LA7 083	2, 4, 6, 8	125	30.5	150	163	154	154	114	114	120	124	37.5	100	32	-	118	36	32	18	50	94	80	8
90 S 90 L	1LA7 090 1LA7 096	2, 4, 6, 8	140	30.5	165	180	162	162	122	122	120	170	37.5	100 125	33	54	143	45.5	32	18	56	143 118	90	10
100 L	1LA7 106 1LA7 107	2, 4, 6, 8 4, 8	160	42	196	203	135	163	78	123	120	170	60	140	47	-	176	39	42	21	63	125	100	12
112 M	1LA7 113	2, 4, 6, 8	190	46	226	227	148	176	91	136	120	170	60	140	47	-	176	32	42	21	70	141	112	12
132 S	1LA7 130 1LA7 131 2	2, 4, 6, 8	216	53	256	267	167	194	107	154	140	250	70	140	49	-	180	39	42	21	89	162.5	132	15
132 M	1LA7 133 1LA7 134 6	4, 6, 8	216	53	256	267	167	194	107	154	140	250	70	178	49	-	218	39	42	21	89	124.5	132	15
160 M	1LA7 163 1LA7 164 2, 8	2, 4, 6, 8 2, 8	254	60	300	320	197	226	127	183	165	250	82.5	210	57	-	256	52.5	54	27	108	183	160	18
160 L	1LA7 166	2, 4, 6, 8	254	60	300	320	197	226	127	183	165	250	82.5	254	57	-	300	52.5	54	27	108	139	160	18
180 M	1LA5 183	2, 4	279	69.5	339	363	258	258	216	216	152	340	71	241	50	-	287	38	54	27	121	259	180	18
180 L	1LA5 186	4, 6, 8	279	69.5	339	363	258	258	216	216	152	340	71	279	50	-	325	38	54	27	121	221	180	18
200 L	1LA5 206 1LA5 207	2, 6 2, 4, 6, 8	318	83	388	402	305	305	252	252	260	340	96	305	58.5	-	355	45	85	42.5	133	239	200	24
225 S	1LA5 220	4, 8	356	103	426	402	305	305	252	252	260	340	96	286	58	83	361	36	85	42.5	149	248.5	225	24
225 M	1LA5 223	2 4, 6, 8	356	103	426	402	305	305	252	252	260	340	96	311	58	83	361	36	85	42.5	149	223.5	225	24

\* This dimension is assigned in DIN EN 50347 to the frame size listed.

<sup>2)</sup> The motors of frame size 56 M are not ventilated.

<sup>1)</sup> Measured across the bolt heads.



#### Dimensional drawings

##### Aluminum series 1LA7 and 1LA5, frame sizes 56 M to 225 M

##### Type of construction IM B35

For flange dimensions, see Page 4/152 (Z = the number of retaining holes)

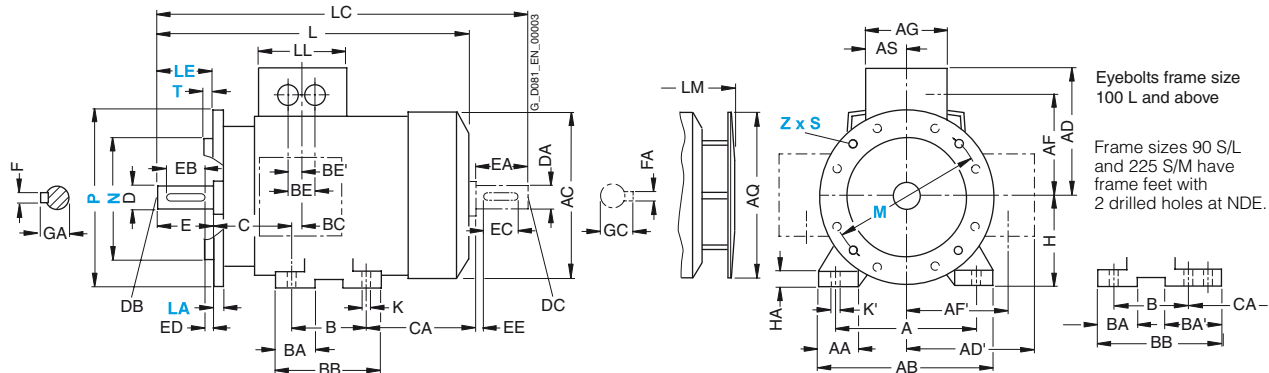

##### Type of construction IM B14

Type of construction IM B14 not possible for 1LA5 motors, frame sizes 180 M to 225 M

For flange dimensions, see Page 4/152 (Z = the number of retaining holes)

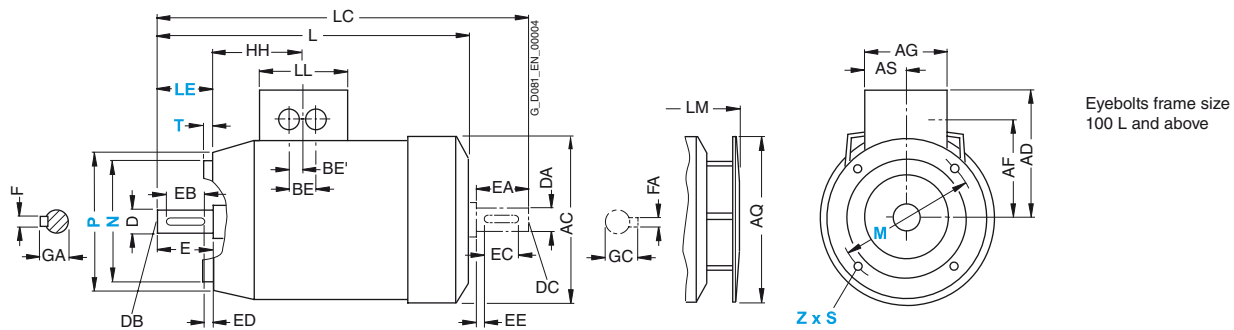

For motor		Dimension designation acc. to IEC							DE shaft extension					NDE shaft extension									
Frame size	Type	Number of poles	HH	K	K'	L	LC	LL	LM	D	DB	E	EB	ED	F	GA	DA	DC	EA	EC	EE	FA	GC
56 M <sup>1)</sup>	1LA7 050 1LA7 053	2, 4	69.5	5.8	9	169	200	120	-	9	M3	20	14	3	3	10.2	9	M3	20	14	3	3	10.2
63 M	1LA7 060 1LA7 063	2, 4, 6	69.5	7	10	202.5 <sup>2)</sup>	232 <sup>2)</sup>	120	231.5 <sup>2)</sup>	11	M4	23	16	3.5	4	12.5	11	M4	23	16	3.5	4	12.5
71 M	1LA7 070 1LA7 073	2, 4, 6, 8	63.5	7	10	240	278	120	268	14	M5	30	22	4	5	16	14	M5	30	22	4	5	16
80 M	1LA7 080 1LA7 083	2, 4, 6, 8	63.5	9.5	13.5	273.5	324 364	120	299.5	19	M6	40	32	4	6	21.5	19	M6	40	32	4	6	21.5
90 S 90 L	1LA7 090 1LA7 096	2, 4, 6, 8	79	10	14	331	389	120	382.5	24	M8	50	40	5	8	27	19	M6	40	32	4	6	21.5
100 L	1LA7 106 1LA7 107 4, 8	2, 4, 6, 8	102	12	16	372	438	120	423.5	28	M10	60	50	5	8	31	24	M8	50	40	5	8	27
112 M	1LA7 113	2, 4, 6, 8	102	12	16	393	461	120	444.5	28	M10	60	50	5	8	31	24	M8	50	40	5	8	27
132 S	1LA7 130 1LA7 131 2	2, 4, 6, 8	128	12	16	452.5 <sup>3)</sup>	551.5	140	505 <sup>3)</sup>	38	M12	80	70	5	10	41	38	M12	80	70	5	10	41
132 M	1LA7 133 4, 6, 8 1LA7 134 6	2, 4, 6, 8	128	12	16	452.5 <sup>3)</sup>	551.5	140	505 <sup>3)</sup>	38	M12	80	70	5	10	41	38	M12	80	70	5	10	41
160 M	1LA7 163 1LA7 164 2, 8	2, 4, 6, 8	160.5	15	19	588	721	165	640.5	42	M16	110	90	10	12	45	42	M16	110	90	10	12	45
160 L	1LA7 166	2, 4, 6, 8	160.5	15	19	588	721	165	640.5	42	M16	110	90	10	12	45	42	M16	110	90	10	12	45
180 M	1LA5 183	2, 4	159	15	19	712	841	132	793.5	48	M16	110	100	5	14	51.5	48	M16	110	100	5	14	51.5
180 L	1LA5 186	4, 6, 8	159	15	19	712	841	132	793.5	48	M16	110	100	5	14	51.5	48	M16	110	100	5	14	51.5
200 L	1LA5 206 1LA5 207	2, 6 2, 4, 6, 8	178	19	25	769.5	897	192	850	55	M20	110	100	5	16	59	55	M20	110	100	5	16	59
225 S	1LA5 220	4, 8	184.5	19	25	806	933.5	192	887.5	60	M20	140	125	7.5	18	64	55	M20	110	100	5	16	59
225 M	1LA5 223	2 4, 6, 8	184.5	19	25	776 806	903.5 933.5	192	857.5 887.5	55 60	M20	110 140	100 125	5 7.5	16 18	59 64	55	M20	110	100	5	16	59

<sup>1)</sup> The motors of frame size 56 M are not ventilated.

<sup>2)</sup> For 1LA7 063 with type of construction code 1 (B5, IM V1 without protective cover, IM V3) the dimensions L, LC and LM are 26 mm longer.

<sup>3)</sup> In a low-noise version, the dimension L is 8 mm greater and the dimension LM is 11.5 mm greater.

# IEC Squirrel-Cage Motors

## Explosion-proof motors

### Dimensions

#### Dimensional drawings

Aluminum series 1LA9, frame sizes 56 M to 200 L

#### Type of construction IM B3

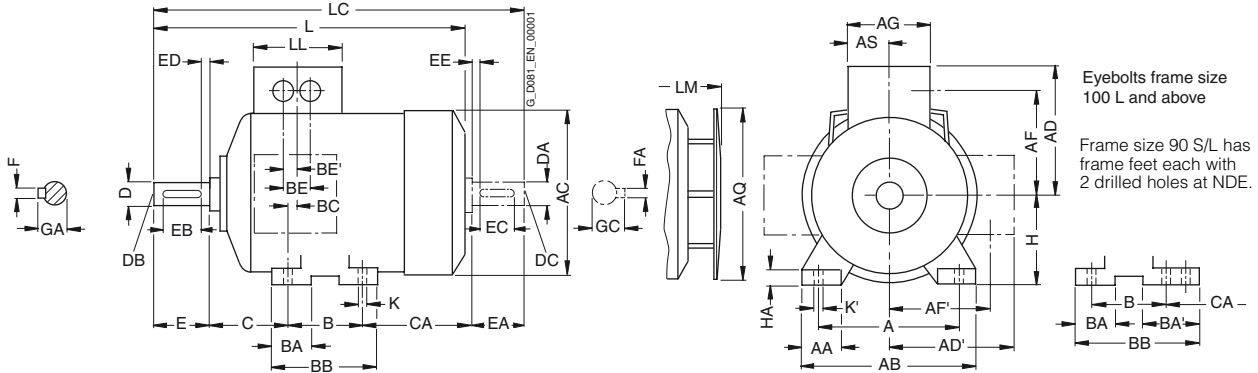

#### Types of construction IM B5 and IM V1

For flange dimensions, see Page 4/152 (Z = the number of retaining holes)

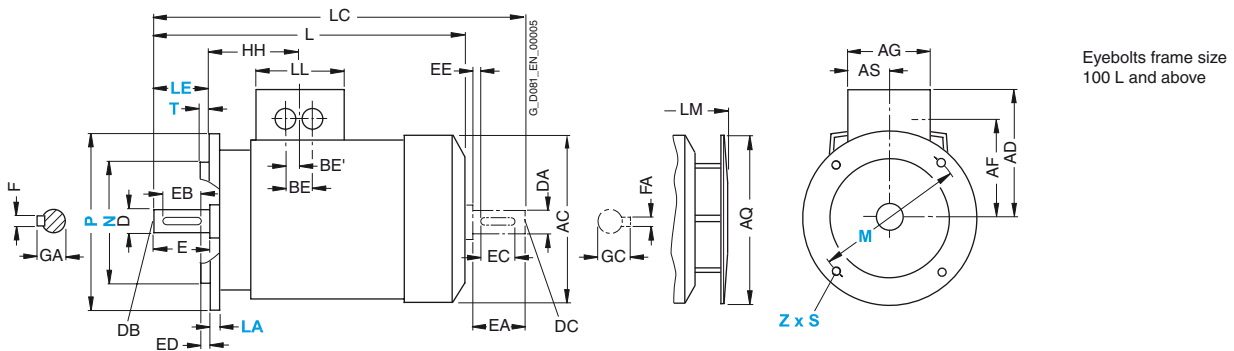

For motor		Dimension designation acc. to IEC																						
Frame size	Type	Number of poles	A	AA	AB	AC <sup>1)</sup>	AD	AD'	AF	AF'	AG	AQ	AS	B*	BA	BA'	BB	BC	BE	BE'	C	CA*	H	HA
56 M <sup>2)</sup>	1LA9 050	2, 4	90	25	110	116	135	135	95	95	120	-	37	71	28	-	87	56	32	18	36	53	56	6
	1LA9 053																							
63 M	1LA9 060	2, 4	100	27	120	124	135	135	95	95	120	124	37	80	28	-	96	52	32	18	40	66	63	7
	1LA9 063																							
71 M	1LA9 070	2, 4	112	30.5	132	145	145	145	105	105	120	124	37	90	27	-	106	41	32	18	45	83	71	7
	1LA9 073																							
80 M	1LA9 080	2, 4	125	30.5	150	163	154	154	114	114	120	124	37.5	100	32	-	118	36	32	18	50	94	80	8
	1LA9 083																							
90 S	1LA9 090	2, 4, 6	140	30.5	165	180	162	162	122	122	120	170	37.5	100	33	54	143	45.5	32	18	56	143	90	10
100 L	1LA9 106	2, 4, 6	160	42	196	203	135	163	78	123	120	170	60	140	47	-	176	39	42	21	63	160	100	12
	1LA9 107																							
112 M	1LA9 113	2, 4, 6	190	46	226	227	148	176	91	136	120	170	60	140	47	-	176	32	42	21	70	179	112	12
132 S	1LA9 130	2, 4	216	53	256	267	167	194	107	154	140	250	70	140	49	-	180	39	42	21	89	162.5	132	15
	1LA9 131																							
132 M	1LA9 133	2	216	53	256	267	167	194	107	154	140	250	70	178	49	-	218	39	42	21	89	124.5	132	15
	1LA9 133	4																						
	1LA9 134	6																						
160 M	1LA9 163	2, 4, 6	254	60	300	320	197	226	127	183	165	250	82.5	210	57	-	256	52.5	54	27	108	183	160	18
	1LA9 164																							
160 L	1LA9 166	2, 4, 6	254	60	300	320	197	226	127	183	165	250	82.5	254	57	-	300	52.5	54	27	108	179	160	18
180 M	1LA9 183	2, 4	279	69.5	339	363	258	258	216	216	152	340	71	241	50	-	287	38	54	27	121	259	180	18
180 L	1LA9 186	4, 6	279	69.5	339	363	258	258	216	216	152	340	71	279	50	-	325	38	54	27	121	221	180	18
200 L	1LA9 206	2, 6	318	83	388	402	305	305	252	252	260	340	96	305	58.5	-	355	45	85	42.5	133	239	200	24
	1LA9 207																							

\* This dimension is assigned in DIN EN 50347 to the frame size listed.

<sup>1)</sup> Measured across the bolt heads.

<sup>2)</sup> The motors of frame size 56 M are not ventilated. Frame size 56 M is not available in IM B35.

<sup>3)</sup> For 1LA9 107-4KA.

#### Dimensional drawings

##### Aluminum series 1LA9, frame sizes 56 M to 200 L

##### Type of construction IM B35

For flange dimensions, see Page 4/152 (Z = the number of retaining holes)

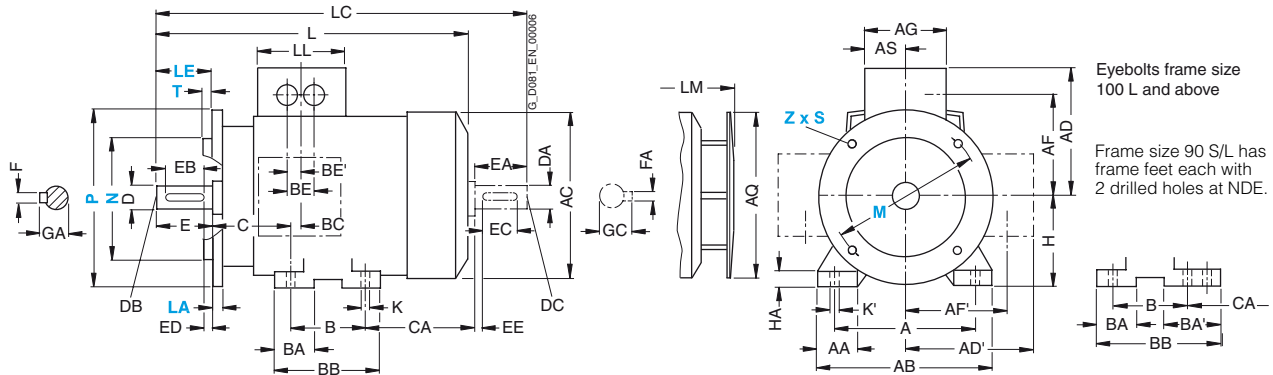

##### Type of construction IM B14

Type of construction IM B14 not possible for 1LA9 motors, frame sizes 180 M to 200 L

For flange dimensions, see Page 4/152 (Z = the number of retaining holes)

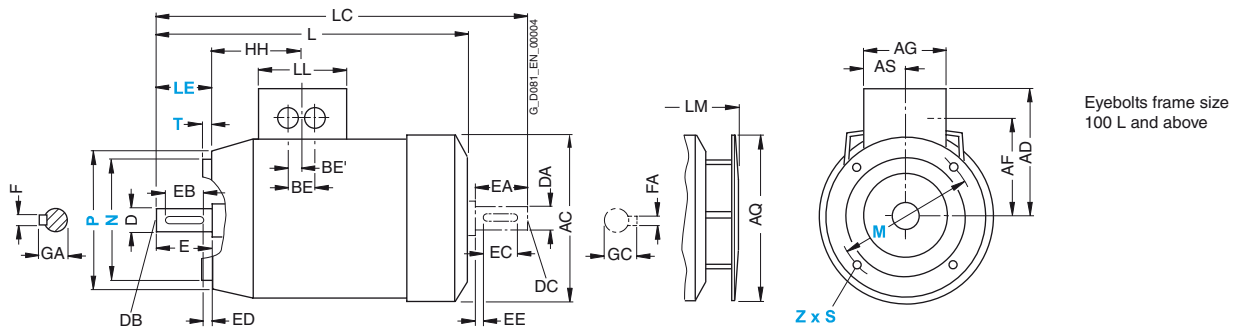

For motor		Number of poles	Dimension designation acc. to IEC								DE shaft extension					NDE shaft extension							
Frame size	Type		HH	K	K'	L	LC	LL	LM	D	DB	E	EB	ED	F	GA	DA	DC	EA	EC	EE	FA	GC
56 M <sup>1)</sup>	1LA9 050 1LA9 053	2, 4	69.5	5.8	9	169 <sup>2)</sup>	200 <sup>2)</sup>	120	-	9	M3	20	14	3	3	10.2	9	M3	20	14	3	3	10.2
63 M	1LA9 060 1LA9 063	2, 4	69.5	7	10	202.5 <sup>3)</sup> 228.5	232 <sup>3)</sup> 258	120	231.5 257.5	11	M4	23	16	3.5	4	12.5	11	M4	23	16	3.5	4	12.5
71 M	1LA9 070 1LA9 073	2, 4	63.5	7	10	240	278	120	268	14	M5	30	22	4	5	16	14	M5	30	22	4	5	16
80 M	1LA9 080 1LA9 083	2, 4	63.5	9.5	13.5	273.5 308.5	324 364	120	299.5 334.5	19	M6	40	32	4	6	21.5	19	M6	40	32	4	6	21.5
90 S 90 L	1LA9 090 1LA9 096	2, 4, 6	79	10	14	331 376 <sup>4)</sup> 358 <sup>5)</sup>	389 434 <sup>4)</sup> 414 <sup>5)</sup>	120	382.5 427.5 <sup>4)</sup> 409.5 <sup>5)</sup>	24	M8	50	40	5	8	27	19	M6	40	32	4	6	21.5
100 L	1LA9 106 1LA9 107	2, 4, 6	102	12	16	407 442 <sup>6)</sup>	473 508 <sup>6)</sup>	120	458.5 493 <sup>6)</sup>	28	M10	60	50	5	8	31	24	M8	50	40	5	8	27
112 M	1LA9 113	2, 4, 6	102	12	16	431	499	120	482.5	28	M10	60	50	5	8	31	24	M8	50	40	5	8	27
132 S	1LA9 130 1LA9 131	2, 4 2	128	12	16	452.5 490.5	551.5 589.5	140	505 543	38	M12	80	70	5	10	41	38	M12	80	70	5	10	41
132 M	1LA9 133 1LA9 133 1LA9 134	6 4 6	128	12	16	452.5 490.5	551.5 589.5	140	505 543	38	M12	80	70	5	10	41	38	M12	80	70	5	10	41
160 M	1LA9 163 1LA9 164	2, 4, 6 2	160.5	15	19	588	721	165	640.5	42	M16	110	90	10	12	45	42	M16	110	90	10	12	45
160 L	1LA9 166	2, 4, 6	160.5	15	19	628	761	165	680.5	42	M16	110	90	10	12	45	42	M16	110	90	10	12	45
180 M	1LA9 183	2, 4	159	15	19	712	841	132	793.5	48	M16	110	100	5	14	51.5	48	M16	110	100	5	14	51.5
180 L	1LA9 186	4, 6	159	15	19	712	841	132	793.5	48	M16	110	100	5	14	51.5	48	M16	110	100	5	14	51.5
200 L	1LA9 206 1LA9 207	2, 6 2, 4, 6	178	19	25	768.5	897	192	850	55	M20	110	100	5	16	59	55	M20	110	100	5	16	59

1) The motors of frame size 56 M are not ventilated. Frame size 56 M is not available in IM B35.  
 2) For 1LA9 frame size 56 M with type of construction code 1 (B5, IM V1 without protective cover, IM V3) the dimensions L, LC and LM are 26 mm longer.

3) For 1LA9 060 with type of construction code 1 (B5, IM V1 without protective cover, IM V3) the dimensions L, LC and LM are 26 mm longer.  
 4) For 1LA9 096-6KA.  
 5) For 1LA9 096-2 and 1LA9 096-4.  
 6) For 1LA9 107-4KA.

# IEC Squirrel-Cage Motors

## Explosion-proof motors

### Dimensions

#### Dimensional drawings

Cast-iron series 1LA6, frame sizes 100 L to 160 L

#### Type of construction IM B3

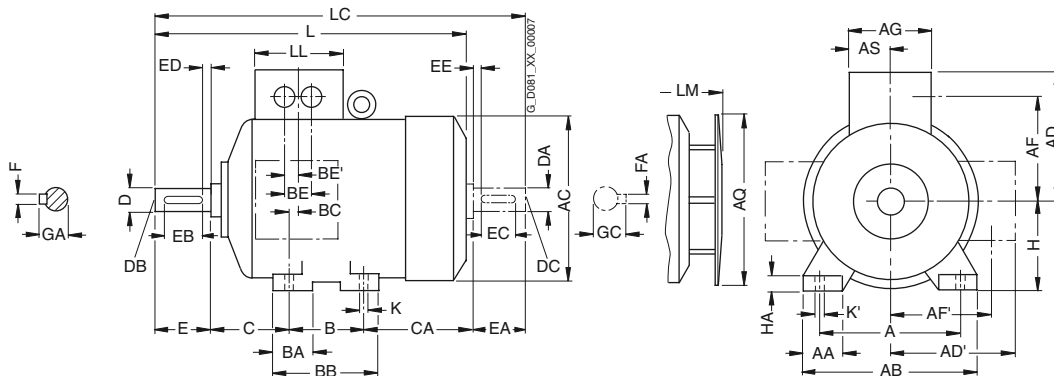

#### Types of construction IM B5 and IM V1

For flange dimensions, see Page 4/152 (Z = the number of retaining holes)

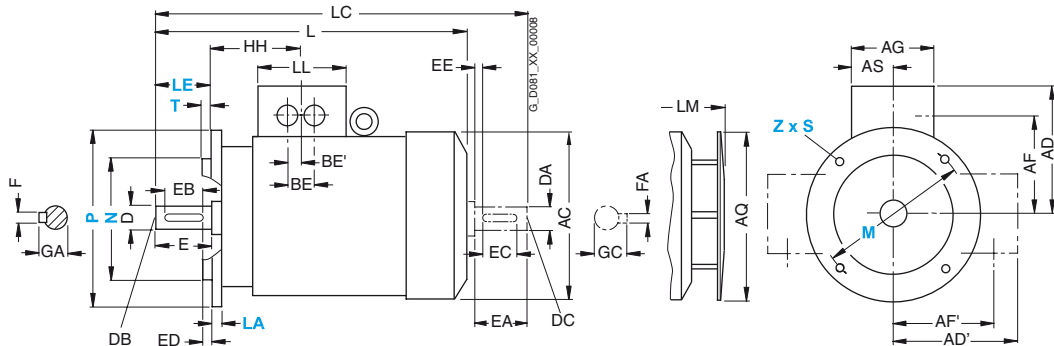

4

For motor			Dimension designation acc. to IEC																				
Frame size	Type	Number of poles	A	AA	AB	AC <sup>1)</sup>	AD	AD'	AF	AF'	AG	AQ	AS	B	BA	BB	BC	BE	BE'	C	CA	H	HA
100 L	1LA6 106	2, 4, 6, 8	160	40	196	201	164	164	124	124	121	170	60.5	140	46	180	42	44	22	63	125	100	12
	1LA6 107	4, 8																					
112 M	1LA6 113	2, 4, 6, 8	190	42.5	226	225.5	178	178	138	138	121	170	60.5	140	46	180	34	44	22	70	141	112	15
132 S	1LA6 130	2, 4, 6, 8	216	50	256	265	194	194	154	154	141	250	70.5	140	47	180	42	44	22	89	162.5	132	17
	1LA6 131	2																					
132 M	1LA6 133	4, 6, 8	216	50	256	265	194	194	154	154	141	250	70.5	178	49	218	42	44	22	89	124.5	132	17
	1LA6 134	6																					
160 M	1LA6 163	2, 4, 6, 8	254	60	300	320	226	226	183	183	166	250	83	210	63	256	52	54	27	108	183	160	18
	1LA6 164	2, 8																					
160 L	1LA6 166	2, 4, 6, 8	254	60	300	320	226	226	183	183	166	250	83	254	63	300	52	54	27	108	139	160	18

<sup>1)</sup> Measured across the bolt heads.

#### Dimensional drawings

Cast-iron series 1LA6, frame sizes 100 L to 160 L

#### Type of construction IM B35

For flange dimensions, see Page 4/152 (Z = the number of retaining holes)

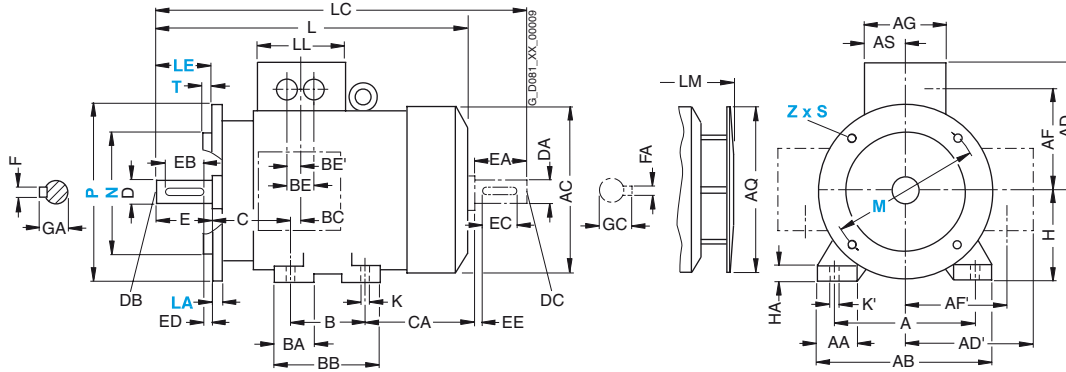

#### Types of construction IM B14

For flange dimensions, see Page 4/152 (Z = the number of retaining holes)

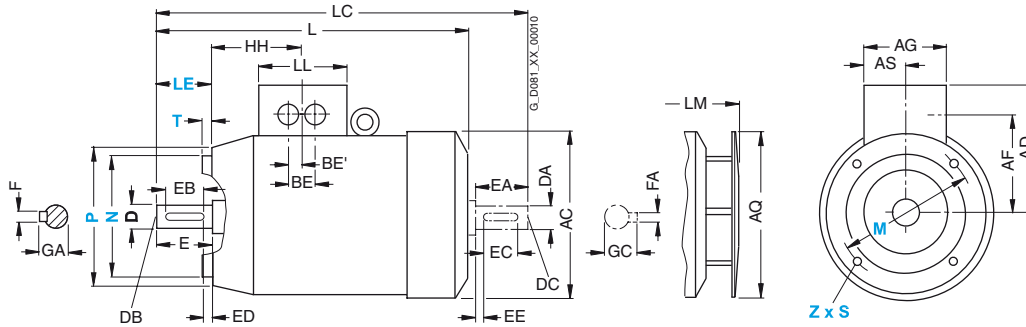

For motor		Number of poles	Dimension designation acc. to IEC							DE shaft extension					NDE shaft extension								
Frame size	Type		HH	K	K'	L	LC	LL	LM	D	DB	E	EB	ED	F	GA	DA	DC	EA	EC	EE	FA	GC
100 L	1LA6 106	2, 4, 6, 8	104.5	12	16	372	438	121	423.5	28	M10	60	50	5	8	31	24	M8	50	40	5	8	27
	1LA6 107	4, 8																					
112 M	1LA6 113	2, 4, 6, 8	104.5	12	16	393	461	121	444.5	28	M10	60	50	5	8	31	24	M8	50	40	5	8	27
132 S	1LA6 130	2, 4, 6, 8	130.5	12	16	453.5	551.5	141	506	38	M12	80	70	5	10	41	38	M12	80	70	5	10	41
	1LA6 131	2																					
132 M	1LA6 133	4, 6, 8	130.5	12	16	453.5	551.5	141	506	38	M12	80	70	5	10	41	38	M12	80	70	5	10	41
	1LA6 134	6																					
160 M	1LA6 163	2, 4, 6, 8	160	14.5	18	588	721	166	640.5	42	M16	110	90	10	12	45	42	M16	110	90	10	12	45
	1LA6 164	2, 8																					
160 L	1LA6 166	2, 4, 6, 8	160	14.5	18	588	721	166	640.5	42	M16	110	90	10	12	45	42	M16	110	90	10	12	45



# IEC Squirrel-Cage Motors

## Explosion-proof motors

### Dimensions

#### Dimensional drawings

Cast-iron series 1LG4, frame sizes 180 M to 315 L

#### Type of construction IM B3

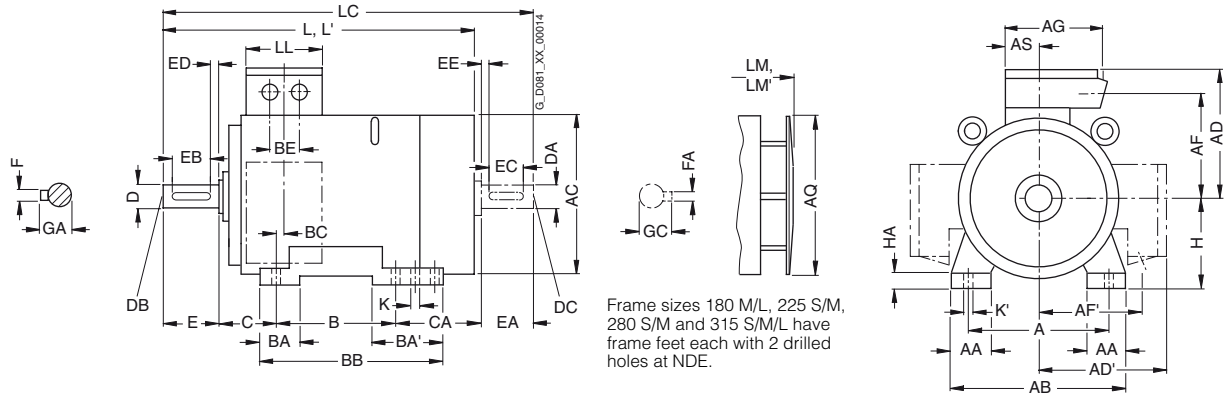

#### Types of construction IM B5 and IM V1

For flange dimensions, see Page 4/152 (Z = the number of retaining holes)

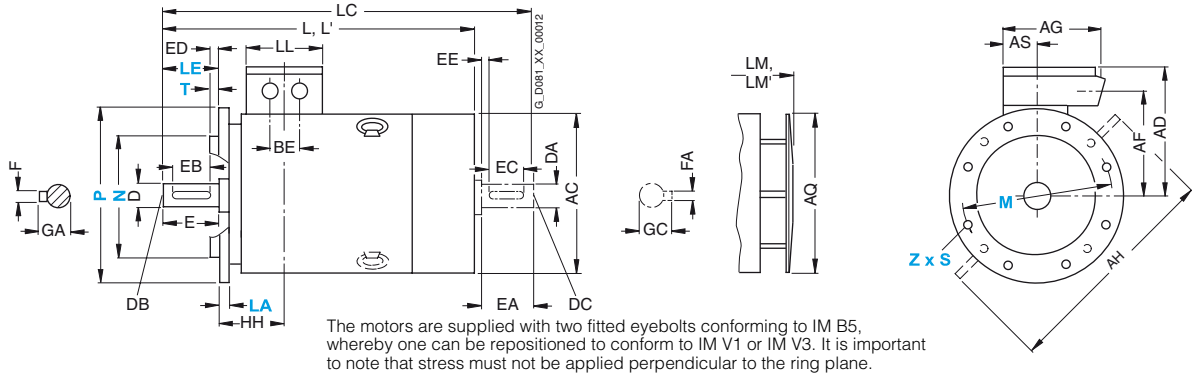

For motor		Dimension designation acc. to IEC																						
Frame size	Type	Number of poles	A	AA	AB	AC <sup>1)</sup>	AD	AD'	AF	AF'	AG	AH	AQ	AS	B*	BA	BA'	BB	BC	BE	C	CA*	H	HA
180 M	1LG4 183	2, 4	279	65	339	363	262	262	220	220	152	452	340	71	241	70	111	328	36	54	121	202	180	20
	180 L	4, 6, 8	279	65	339	363	262	262	220	220	152	452	340	71	279	70	111	328	36	54	121	164	180	20
	1LG4 188	2, 4, 6, 8	279	65	339	363	262	262	220	220	152	452	340	71	279	70	111	328	36	54	121	215	180	20
200 L	1LG4 206	2, 6	318	70	378	402	300	300	247	247	260	512	340	96	305	80	80	355	63	85	133	177	200	25
	1LG4 207	2, 4, 6, 8	318	70	378	402	300	300	247	247	260	512	340	96	305	80	80	355	63	85	133	177	200	25
	1LG4 208	2, 6, 4, 8	318	70	378	402	300	300	247	247	260	512	340	96	305	80	80	355	63	85	133	234	200	25
																								177
225 S	1LG4 220	4, 8	356	80	436	442	325	325	272	272	260	556	425	96	286	85	110	361	47	85	149	218	225	34
225 M	1LG4 223	2	356	80	436	442	325	325	272	272	260	556	425	96	311	85	110	361	47	85	149	193	225	34
	1LG4 228	4, 6, 8	356	80	436	442	325	325	272	272	260	556	425	96	311	85	110	361	47	85	149	253	225	34
250 M	1LG4 253	2	406	100	490	495	392	392	308	308	300	620	470	118	349	100	100	409	69	110	168	235	250	40
	1LG4 258	4, 6, 8	406	100	490	495	392	392	308	308	300	620	470	118	349	100	100	409	69	110	168	235	250	40
		2																					305	
																								235
280 S	1LG4 280	2, 4, 6, 8	457	100	540	555	432	432	348	348	300	672	525	118	368	100	151	479	62	110	190	267	280	40
280 M	1LG4 283	2	457	100	540	555	432	432	348	348	300	672	525	118	419	100	151	479	62	110	190	216	280	40
	1LG4 288	4, 6, 8	457	100	540	555	432	432	348	348	300	672	525	118	419	100	151	479	62	110	190	326	280	40
		2																						
315 S	1LG4 310	2	508	120	610	610	500	500	400	400	380	780	590	154	406	125	176	527	69	110	216	315	315	50
	1LG4 310	4, 6, 8																						
315 M <sup>2)</sup>	1LG4 313	2	508	120	610	610	500	500	400	400	380	780	590	154	457	125	176	527	69	110	216	264	315	50
	1LG4 313	4, 6, 8																						
315 L <sup>2)</sup>	1LG4 316/317	2	508	120	610	610	500	500	400	400	380	780	590	154	508	125	176	578	69	110	216	373	315	50
	1LG4 316/317	4, 6, 8																						
	1LG4 318	8																						
	1LG4 318	6	508	120	610	610	500	500	400	400	380	780	590	154	508	155	206	648	69	110	216	513	315	50

\* This dimension is assigned in DIN EN 50347 to the frame size listed.

1) Measured across the bolt heads.

2) With order codes for connection box positions (K09, K10, K11) only fitted feet with 3 drilled holes with dimension "B" (406, 457 and 508 mm). BB will then be 666 mm.



# IEC Squirrel-Cage Motors

## Explosion-proof motors

### Dimensions

#### Dimensional drawings

Cast-iron series 1LG6, frame sizes 180 M to 250 M

#### Type of construction IM B3

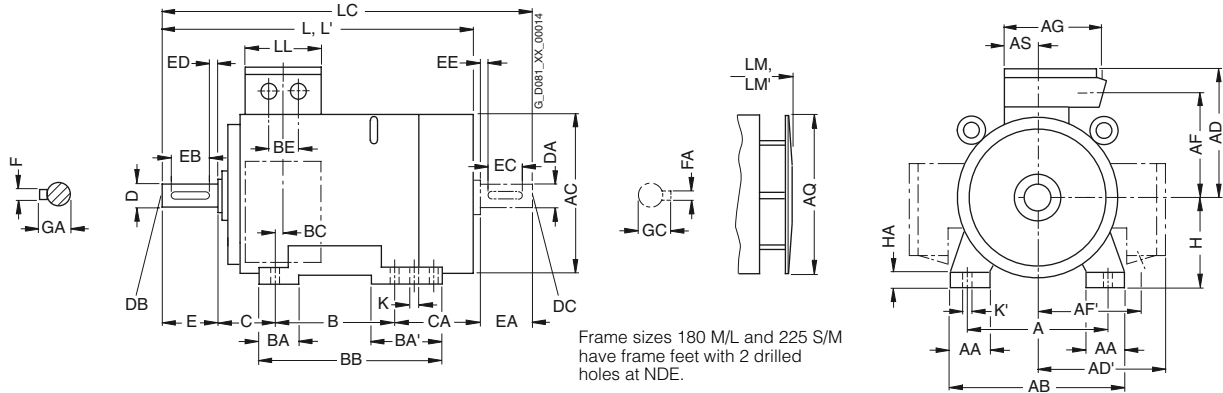

#### Types of construction IM B5 and IM V1

For flange dimensions, see Page 4/152 (Z = the number of retaining holes)

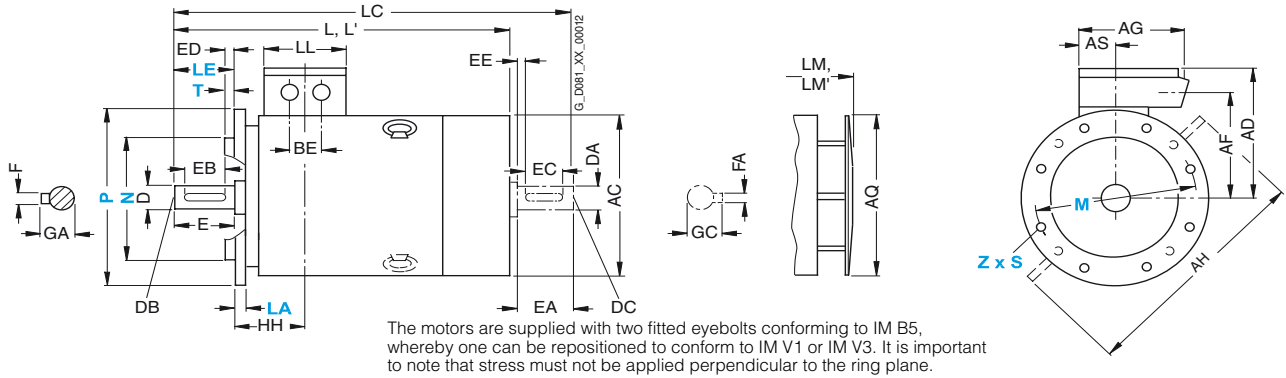

For motor		Number of poles	Dimension designation acc. to IEC																					
Frame size	Type		A	AA	AB	AC <sup>1)</sup>	AD	AD'	AF	AF'	AG	AH	AQ	AS	B*	BA	BA'	BB	BC	BE	C	CA*	H	HA
180 M	1LG6 183	2	279	65	339	363	262	262	220	220	152	452	340	71	241	70	111	328	36	54	121	253	180	20
		4																				202		
180 L	1LG6 186	4, 6, 8	279	65	339	363	262	262	220	220	152	452	340	71	279	70	111	328	36	54	121	215	180	20
		2, 6	318	70	378	402	300	300	247	247	260	512	340	96	305	80	80	355	63	85	133	177	200	25
200 L	1LG6 206	2, 6	318	70	378	402	300	300	247	247	260	512	340	96	305	80	80	355	63	85	133	234	200	25
		4, 8																				177		
225 S	1LG6 220	4, 8	356	80	436	442	325	325	272	272	260	556	425	96	286	85	110	361	47	85	149	218	225	34
		2	356	80	436	442	325	325	272	272	260	556	425	96	311	85	110	361	47	85	149	253	225	34
225 M	1LG6 223	4, 6, 8	356	80	436	442	325	325	272	272	260	556	425	96	311	85	110	361	47	85	149	303	225	34
		2																						
250 M	1LG6 253	2	406	100	490	495	392	392	308	308	300	620	470	118	349	100	100	409	69	110	168	235	250	40
		4																				305		
1LG6 258	2	6, 8	406	100	490	495	392	392	308	308	300	620	470	118	349	100	100	409	69	110	168	235	250	40
		4, 6																				305		

\* This dimension is assigned in DIN EN 50347 to the frame size listed.

1) Measured across the bolt heads.



### Dimensional drawings

Cast-iron series 1LG6, frame sizes 180 M to 250 M

#### Type of construction IM B35

For flange dimensions, see Page 4/152 (Z = the number of retaining holes)

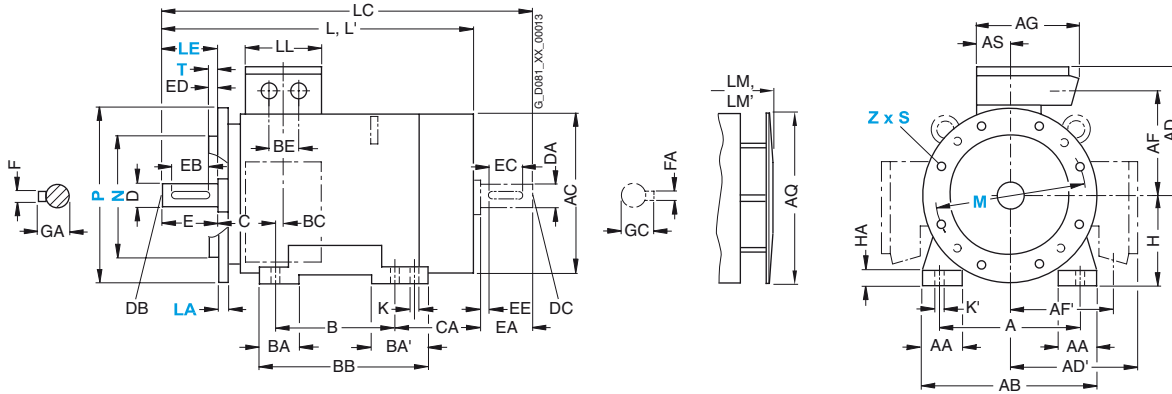

For motor			Dimension designation acc. to IEC													DE shaft extension					NDE shaft extension				
Frame size	Type	Number of poles	HH	K	K'	L	LC	LL	LM	D	DB	E	EB	ED	F	GA	DA	DC	EA	EC	EE	FA	GC		
180 M	1LG6 183	2	157	15	19	720	835	132	810	48	M16	110	100	5	14	51.5	48	M16	110	100	5	14	51.5		
		4				669	784		759																
180 L	1LG6 186	4, 6, 8	157	15	19	720	835	132	810	48	M16	110	100	5	14	51.5	48	M16	110	100	5	14	51.5		
		2, 6	196	19	25	720	835	192	810	55	M20	110	100	5	16	59	55	M20	110	100	5	16	59		
		4, 8	196	19	25	777	892	192	867	55	M20	110	100	5	16	59	55	M20	110	100	5	16	59		
200 L	1LG6 206	2, 6	196	19	25	720	835	192	810	55	M20	110	100	5	16	59	55	M20	110	100	5	16	59		
		4, 8	196	19	25	777	892	192	867	55	M20	110	100	5	16	59	55	M20	110	100	5	16	59		
	1LG6 207	2, 6	196	19	25	720	835	192	810	55	M20	110	100	5	16	59	55	M20	110	100	5	16	59		
		4, 8	196	19	25	777	892	192	867	55	M20	110	100	5	16	59	55	M20	110	100	5	16	59		
225 S	1LG6 220	4, 8	196	19	25	789	903	192	889	60	M20	140	125	10	18	64	55	M20	110	100	5	16	59		
225 M	1LG6 223	2	196	19	25	819	933	192	919	55	M20	110	100	5	16	59	48	M16	110	100	5	14	51.5		
		4, 6, 8				849	963		949	60	M20	140	125	10	18	64	55	M20	110	100	5	16	59		
	1LG6 228	2	196	19	25	869	983	192	969	55	M20	110	100	5	16	59	48	M16	110	100	5	14	51.5		
		4, 6				899	1013		999	60	M20	140	125	10	18	64	55	M20	110	100	5	16	59		
250 M	1LG6 253	2	237	24	30	887	1002	236	987	60	M20	140	125	10	18	64	55	M20	110	100	5	16	59		
		4				957	1102		1057	65	M20	140	125	10	18	69	60	M20	140	125	10	18	64		
		6, 8				887	1032		987	65	M20	140	125	10	18	69	60	M20	140	125	10	18	64		
	1LG6 258	2	237	24	30	957	1102	236	1057	60	M20	140	125	10	18	64	55	M20	110	100	5	16	59		
		4																							
		6, 8																							

# IEC Squirrel-Cage Motors

## Explosion-proof motors

### Dimensions

#### Dimensional drawings

Cast-iron series 1LG6, frame sizes 280 S to 315 L

#### Type of construction IM B3

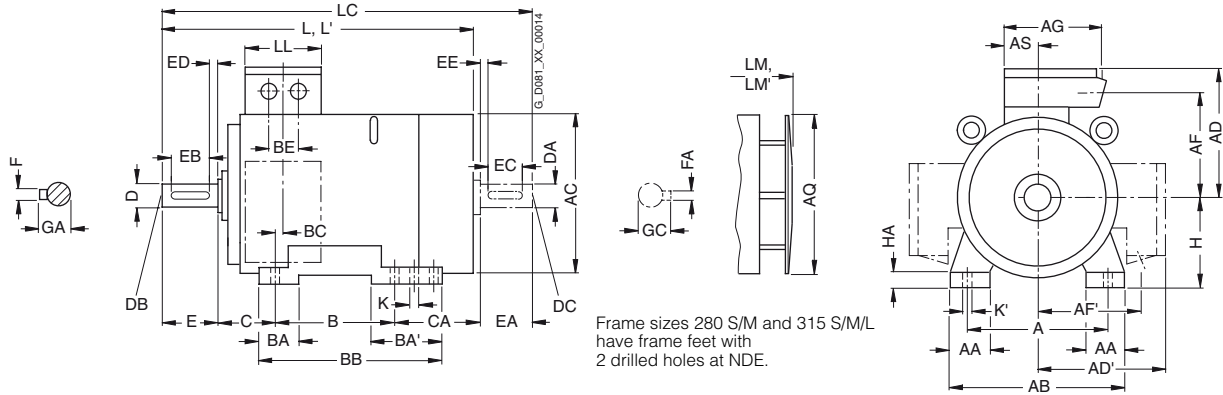

#### Types of construction IM B5 and IM V1

For flange dimensions, see Page 4/152 (Z = the number of retaining holes)

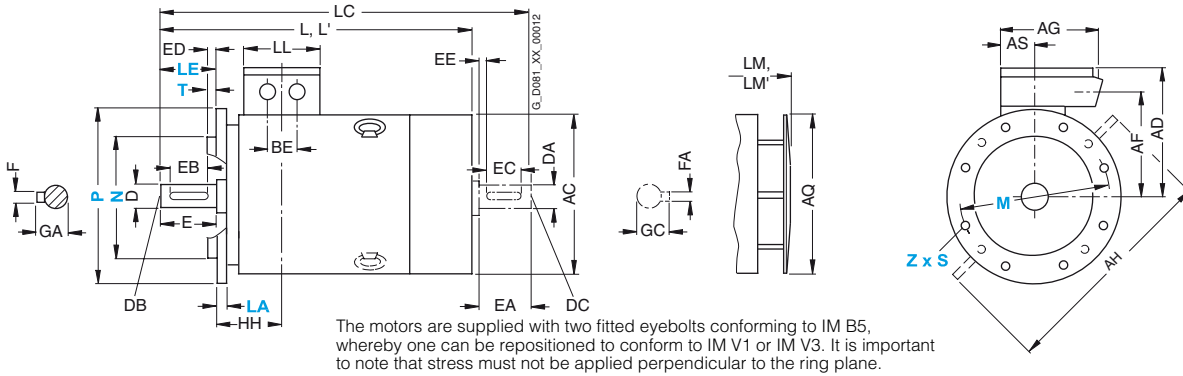

For motor	Frame size	Type	Number of poles	Dimension designation acc. to IEC																					
				A	AA	AB	AC <sup>1)</sup>	AD	AD'	AF	AF'	AG	AH	AQ	AS	B*	BA	BA'	BB	BC	BE	C	CA*	H	HA
	280 S	1LG6 280	2	457	100	540	555	432	432	348	348	300	672	525	118	368	100	151	479	62	110	190	267	280	40
	280 M	1LG6 283	2	457	100	540	555	432	432	348	348	300	672	525	118	419	100	151	479	62	110	190	326	280	40
			4	6, 8	457	100	540	555	432	432	348	348	300	672	525	118	419	100	151	479	62	110	190	326	280
		1LG6 288	2	457	100	540	555	432	432	348	348	300	672	525	118	419	100	151	479	62	110	190	326	280	40
			4, 6																			216	280	40	
	315 S	1LG6 310	2	508	120	610	610	500	500	400	400	380	780	590	154	406	125	176	527	69	110	216	315	315	50
		1LG6 310	4, 6, 8	508	120	610	610	500	500	400	400	380	780	590	154	457	125	176	527	69	110	216	264	315	50
	315 M <sup>2)</sup>	1LG6 313	8	508	120	610	610	500	500	400	400	380	780	590	154	457	125	176	578	69	110	216	424	315	50
			2	508	120	610	610	500	500	400	400	380	780	590	154	457	125	176	578	69	110	216	424	315	50
	315 L <sup>2)</sup>	1LG6 313	4, 6	508	120	610	610	500	500	400	400	380	780	590	154	508	125	176	578	69	110	216	373	315	50
			2	508	120	610	610	500	500	400	400	380	780	590	154	508	125	176	578	69	110	216	373	315	50
		1LG6 316	4, 6	508	120	610	610	500	500	400	400	380	780	590	154	508	155	206	648	69	110	216	513	315	50
		1LG6 316	8	508	120	610	610	500	500	400	400	380	780	590	154	508	155	206	648	69	110	216	513	315	50
		1LG6 317	2	508	120	610	610	500	500	400	400	380	780	590	154	508	155	206	648	69	110	216	513	315	50
		1LG6 317	4, 6	508	120	610	610	500	500	400	400	380	780	590	154	508	155	206	648	69	110	216	513	315	50
		1LG6 317	8	508	120	610	610	500	500	400	400	380	780	590	154	508	155	206	648	69	110	216	513	315	50
		1LG6 318	2	508	120	610	610	651	651	524	524	470	780	590	165	508	155	206	648	69	135	216	513	315	50
		1LG6 318	4	508	120	610	610	651	651	524	524	470	780	590	165	508	155	206	648	69	135	216	513	315	50
		1LG6 318	6, 8	508	120	610	610	500	500	400	400	380	780	590	165	508	155	206	648	69	135	216	513	315	50

\* This dimension is assigned in DIN EN 50347 to the frame size listed.

1) Measured across the bolt heads.

2) With order codes for connection box positions (K09, K10, K11) only fitted feet with 3 drilled holes with dimension "B" (406, 457 and 508 mm). BB will then be 666 mm.

### Dimensional drawings

Cast-iron series 1LG6, frame sizes 280 S to 315 L

#### Type of construction IM B35

For flange dimensions, see Page 4/152 (Z = the number of retaining holes)

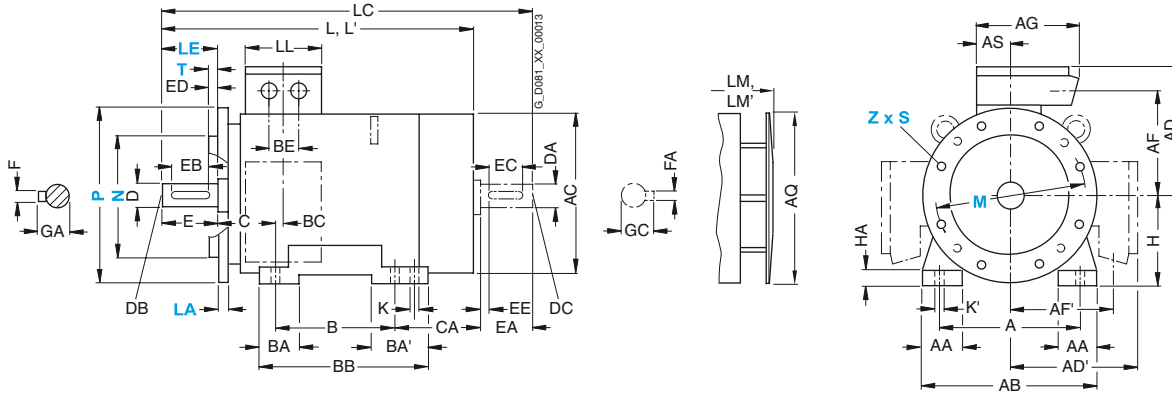

For motor Frame size	Type	Number of poles	Dimension designation acc. to IEC										DE shaft extension				NDE shaft extension						
			HH	K	K'	L	LC	LL	LM	D	DB	E	EB	ED	F	GA	DA	DC	EA	EC	EE	FA	GC
280 S	1LG6 280	2	252	24	30	960	1105	236	1070	65	M20	140	125	10	18	69	60	M20	140	125	10	18	64
		4, 6, 8								75	M20	140	125	10	20	79.5	65	M20	140	125	10	18	69
280 M	1LG6 283	2	252	24	30	1070	1215	236	1180	65	M20	140	125	10	18	69	60	M20	140	125	10	18	64
		4								75	M20	140	125	10	20	79.5	65	M20	140	125	10	18	69
	1LG6 288	6, 8				960	1105		1070	75	M20	140	125	10	20	79.5	65	M20	140	125	10	18	69
		2	252	24	30	1070	1215	236	1180	65	M20	140	125	10	18	69	60	M20	140	125	10	18	64
		4, 6								75	M20	140	125	10	20	79.5	65	M20	140	125	10	18	69
315 S	1LG6 310	2	285	28	35	1072	1217	307	1182	65	M20	140	125	10	18	69	60	M20	140	125	10	18	64
	1LG6 310	4, 6, 8				1102	1247		1212	80	M20	170	140	25	22	85	70	M20	140	125	10	20	74.5
315 M	1LG6 313	8	285	28	35	1102	1247	307	1212	80	M20	170	140	25	22	85	70	M20	140	125	10	20	74.5
	1LG6 313	2	285	28	35	1232	1377	307	1342	65	M20	140	125	10	18	69	60	M20	140	125	10	18	64
	1LG6 313	4, 6				1262	1407		1372	80	M20	170	140	25	22	85	70	M20	140	125	10	20	74.5
315 L	1LG6 316	2	285	28	35	1232	1377	307	1342	65	M20	140	125	10	18	69	60	M20	140	125	10	18	64
	1LG6 316	4, 6				1262	1407		1372	80	M20	170	140	25	22	85	70	M20	140	125	10	20	74.5
	1LG6 316	8							80	M20	170	140	25	22	85	70	M20	140	125	10	20	74.5	
	1LG6 317	2	285	28	35	1372	1517	307	1482	65	M20	140	125	10	18	69	60	M20	140	125	10	18	64
	1LG6 317	4, 6				1402	1547		1512	80	M20	170	140	25	22	85	70	M20	140	125	10	20	74.5
	1LG6 317	8				1262	1407		1372	80	M20	170	140	25	22	85	70	M20	140	125	10	20	74.5
	1LG6 318	2	285	28	35	1372	1517	330	1482	65	M20	140	125	10	18	69	60	M20	140	125	10	18	64
	1LG6 318	4				1402	1547		1512	80 <sup>1)</sup>	M20	170	140	25	22	85	70	M20	140	125	10	20	74.5
	1LG6 318	6, 8						307	80	M20	170	140	25	22	85	70	M20	140	125	10	20	74.5	

<sup>1)</sup> Diameters up to 90 mm are possible.

# IEC Squirrel-Cage Motors

## Explosion-proof motors

### Dimensions

#### Dimensional drawings

##### Flange dimensions

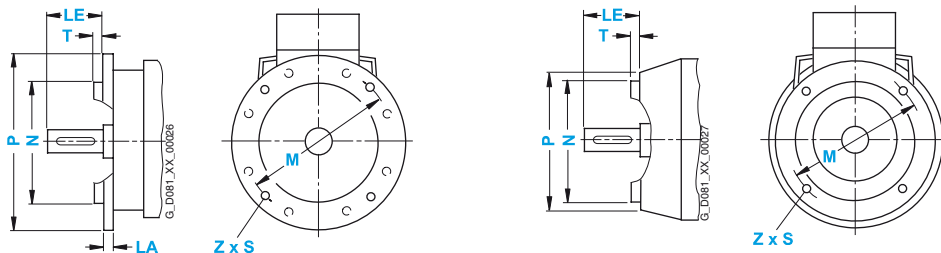

In DIN EN 50347, the frame sizes are allocated flange FF with through holes and flange FT with tapped holes. The designation of flange A and C according to DIN 42948 (invalid since 09/2003) are also listed for information purposes. See the table below. (Z = the number of retaining holes)

Frame size	Type of construction	Flange type	Flange with through holes (FF/A) Tapped holes (FT/C)		Dimension designation acc. to IEC							
			According to DIN EN 50347	Acc. to DIN 42948	LA	LE	M	N	P	S	T	Z
<b>56 M</b>	IM B5, IM B35, IM V1, IM V3	Flange	<b>FF 100</b>	A 120	8	20	100	80	120	7	3	4
	IM B14, IM B34, IM V18, IM V19	Standard flange	<b>FT 65</b>	C 80	–	20	65	50	80	M5	2.5	4
	IM B14, IM B34, IM V18, IM V19	Special flange	<b>FT 85</b>	C 105	–	20	85	70	105	M6	2.5	4
<b>63 M</b>	IM B5, IM B35, IM V1, IM V3	Flange	<b>FF 115</b>	A 140	8	23	115	95	140	10	3	4
	IM B14, IM B34, IM V18, IM V19	Standard flange	<b>FT 75</b>	C 90	–	23	75	60	90	M5	2.5	4
	IM B14, IM B34, IM V18, IM V19	Special flange	<b>FT 100</b>	C 120	–	23	100	80	120	M6	3	4
<b>71 M</b>	IM B5, IM B35, IM V1, IM V3	Flange	<b>FF 130</b>	A 160	9	30	130	110	160	10	3.5	4
	IM B14, IM B34, IM V18, IM V19	Standard flange	<b>FT 85</b>	C 105	–	30	85	70	105	M6	2.5	4
	IM B14, IM B34, IM V18, IM V19	Special flange	<b>FT 115</b>	C 140	–	30	115	95	140	M8	3	4
<b>80 M</b>	IM B5, IM B35, IM V1, IM V3	Flange	<b>FF 165</b>	A 200	10	40	165	130	200	12	3.5	4
	IM B14, IM B34, IM V18, IM V19	Standard flange	<b>FT 100</b>	C 120	–	40	100	80	120	M6	3	4
	IM B14, IM B34, IM V18, IM V19	Special flange	<b>FT 130</b>	C 160	–	40	130	110	160	M8	3.5	4
<b>90 S, 90 L</b>	IM B5, IM B35, IM V1, IM V3	Flange	<b>FF 165</b>	A 200	10	50	165	130	200	12	3.5	4
	IM B14, IM B34, IM V18, IM V19	Standard flange	<b>FT 115</b>	C 140	–	50	115	95	140	M8	3	4
	IM B14, IM B34, IM V18, IM V19	Special flange	<b>FT 130</b>	C 160	–	50	130	110	160	M8	3.5	4
<b>100 L</b>	IM B5, IM B35, IM V1, IM V3	Flange	<b>FF 215</b>	A 250	11	60	215	180	250	14.5	4	4
	IM B14, IM B34, IM V18, IM V19	Standard flange	<b>FT 130</b>	C 160	–	60	130	110	160	M8	3.5	4
	IM B14, IM B34, IM V18, IM V19	Special flange	<b>FT 165</b>	C 200	–	60	165	130	200	M10	3.5	4
<b>112 M</b>	IM B5, IM B35, IM V1, IM V3	Flange	<b>FF 215</b>	A 250	11	60	215	180	250	14.5	4	4
	IM B14, IM B34, IM V18, IM V19	Standard flange	<b>FT 130</b>	C 160	–	60	130	110	160	M8	3.5	4
	IM B14, IM B34, IM V18, IM V19	Special flange	<b>FT 165</b>	C 200	–	60	165	130	200	M10	3.5	4
<b>132 S, 132 M</b>	IM B5, IM B35, IM V1, IM V3	Flange	<b>FF 265</b>	A 300	12	80	265	230	300	14.5	4	4
	IM B14, IM B34, IM V18, IM V19	Standard flange	<b>FT 165</b>	C 200	–	80	165	130	200	M10	3.5	4
	IM B14, IM B34, IM V18, IM V19	Special flange	<b>FT 215</b>	C 250	–	80	215	180	250	M12	4	4
<b>160 M, 160 L</b>	IM B5, IM B35, IM V1, IM V3	Flange	<b>FF 300</b>	A 350	13	110	300	250	350	18.5	5	4
	IM B14, IM B34, IM V18, IM V19	Standard flange	<b>FT 215</b>	C 250	–	110	215	180	250	M12	4	4
	IM B14, IM B34, IM V18, IM V19	Special flange	<b>FT 265</b>	C 300	–	110	265	230	300	M12	4	4
<b>180 M, 180 L</b>	IM B5, IM V1, IM V3	Flange	<b>FF 300</b>	A 350	13	110	300	250	350	18.5	5	4
<b>200 L</b>	IM B5	Flange	<b>FF 350</b>	A 400	15	110	350	300	400	18.5	5	4
<b>225 S, 225 M</b> 2-pole 4-pole to 8-pole	IM B5, IM V1, IM V3	Flange	<b>FF 400</b>	A 450	16	110	400	350	450	18.5	5	8
<b>250 M</b>	IM B5, IM V1, IM V3	Flange	<b>FF 500</b>	A 550	18	140	500	450	550	18.5	5	8
<b>280 S, 280 M</b>	IM B5, IM V1, IM V3	Flange	<b>FF 500</b>	A 550	18	140	500	450	550	18.5	5	8
<b>315 S, 315 M, 315 L</b> 2-pole 4-pole to 8-pole	IM B5, IM V1, IM V3	Flange	<b>FF 600</b>	A 660	22	140	600	550	660	24	6	8

# Motors operating with frequency converters



5/2	<b>Orientation</b>	5/18	<b>Special versions</b>
5/2	Overview	5/18	Overview
5/2	Benefits	5/20	Selection and ordering data
5/2	Application	5/20	• Voltages
5/3	Integration	5/21	• Types of construction
5/5	Technical specifications	5/22	• Options
5/9	Selection and ordering data		
5/9	More information	5/32	<b>Accessories</b>
		5/32	Overview
5/10	<b>Surface-cooled motors with standard insulation for voltages ≤500 V, Aluminum or cast-iron housing</b>	5/32	More information
5/10	Overview		
5/12	<b>Self-ventilated motors with special insulation for voltages up to 690 V, Aluminum series 1LA7 and 1LA5</b>	5/33	<b>Dimensions</b>
5/12	Selection and ordering data	5/33	Overview
		5/34	Dimensional drawings
		5/40	More information
5/14	<b>Self-ventilated motors with special insulation for voltages up to 690 V, Cast-iron series 1LG6</b>		
5/14	Selection and ordering data		
5/17	<b>Self-ventilated motors up to FS 315 with special insulation for voltages up to 690 V, Cast-iron series 1LA8</b>		
5/17	Overview		
5/17	Selection and ordering data		
5/17	<b>Forced ventilated motors from frame size 315 with mounted separately driven fan with special insulation for voltages up to 690 V, Cast-iron series 1PQ8</b>		
5/17	Overview		
5/17	Selection and ordering data		

# IEC Squirrel-Cage Motors

## Motors operating with frequency converters

### Orientation

#### Overview

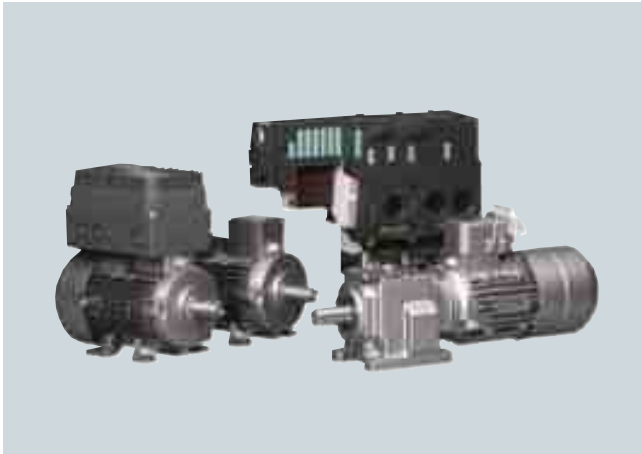

#### Converter-fed operation up to 500 V +10 % mains voltage

The standard insulation of the 1LA and 1LG motors is designed such that operation is possible on the converter at mains voltages up to 460 V +10 % (for motor series 1LA8 to 500 V +10 %). This also applies for operation with a pulse-controlled AC converter with voltage rise times of  $t_{\text{e}} > 0.1 \mu\text{s}$  at the motor terminals (IGBT transistors). At higher voltages, the motors require greater insulation resistance. Please inquire in the case of converter-fed operation with motors with protruding connection cables (order codes **L44**, **L45**, **L47**, **L48**, **L49**, **L51** and **L52**).

The 1LA8 non-standard motors of the types specially identified for converter-fed operation (the 9th and 10th position of the Order No. is filled with “**PB**”, “**PC**” or “**PE**”) have an insulated motor bearing as standard at the non-drive end NDE (BS). The motors are equipped with standard insulation and standard rotors and are suitable for mains-fed and converter-fed operation.

#### Converter-fed operation up to 690 V +10 % mains voltage

1LA5, 1LA7 and 1LG6 standard motors as well as 1LA8 and 1PQ8 non-standard motors are also available with a higher insulation resistance for operation on the converter with supply voltages from 500 V ... 690 V (+10 %), and do not usually require a filter. These motors are identified by an “**M**” in the 10th digit of the Order No. (e.g. 1LA8315-2PM). With the reinforced insulating system, there is less space in the grooves in motor series 1LA8 and 1PQ8 for the same number of windings compared to the normal version, which slightly reduces the rated output of these motors.

#### Converter-fed operation for motors in type of protection “d” up to 460 V +10 % mains voltage

Siemens 1MJ asynchronous motors can be operated on the mains as well as on a converter as explosion-proof motors in type of protection Ex de IIC “Explosion-proof enclosure”. In accordance with the test specifications, 1MJ motors must be equipped with PTC thermistors. When 1MJ motors are connected to converters, like the 1LA motors of the same output, depending on their load characteristics their maximum admissible torque must be reduced. 1MJ motors have a connection box in type of protection Ex e II “Increased safety” as standard.

#### Note:

Special measures are necessary in the case of high-speed motors, especially when separately driven fans are used. Please contact your local Siemens office for advice.

5

#### Benefits

Motors operating with frequency converters from Siemens offer the user numerous advantages:

- The motors feature the future-oriented insulation system DURIGNIT IR 2000 (IR = Inverter Resistant). The DURIGNIT IR 2000 insulating system is made up of high-quality enamel wires and insulating materials in conjunction with a resin impregnation which does not contain any solvents.

The specially developed motors on the frequency converter with special insulation are converter-compatible from 500 V to 690 V (+10 %).

#### Application

The motors can be used in numerous drive applications with variable-speed drives when they are combined with converters from the MICROMASTER and SINAMICS spectrum.

The wide field of implementation includes the following applications:

- Conveyor systems such as cranes, belts and lifting gear
- High-bay warehouses
- Packaging machines
- Automation and Drives

Their large range of mains voltages enables them to be used all over the world.

# IEC Squirrel-Cage Motors

## Motors operating with frequency converters

Orientation

### Integration

#### *MICROMASTER 411/COMBIMASTER 411 distributed drive solutions*

MICROMASTER 411/COMBIMASTER 411 is included in the DA 51.3 Catalog that includes the entire product range with ordering data, technical specifications and explanations.

#### Application

MICROMASTER 411 and COMBIMASTER 411 are the ideal solution for distributed drive applications that require a high degree of protection for the converter. The devices are designed for a wide drive range – for simple individual applications for pumps and fans through to multiple drives for conveyor systems in networked control systems. The ECOFAST versions of the MICROMASTER 411/COMBIMASTER 411 frequency converter series contain plug-in cables for the power supply, communications interface and motor connections. They support fast and problem-free replacement in time-critical applications and are completely compatible with the ECOFAST technology systems. They are based on the universal MICROMASTER 420 converter series and are characterized by customer-oriented performance and ease of use.

#### Structure

The modular structure allows MICROMASTER 411/COMBIMASTER 411 products and their accessories to be individually selected, e.g. electromechanical brake control module or PROFIBUS module.

#### Main features:

- Output range: 0.37 to 3.0 kW, 400 V, 3AC
- IP66 degree of protection (MICROMASTER 411), self-cooling
- Electrical isolation between the electronics and the connection terminals
- Parameter sets for fast startup and cost savings
- Modular structure with numerous accessories
- Operation without operator panel possible (using jumpers and/or control potentiometer)
- Integrated control potentiometer accessible from outside.

#### Accessories (overview):

- Basic Operator Panel (BOP) for parameterizing the converter
- Plain text Advanced Operator Panel (AOP) for MICROMASTER 411 and COMBIMASTER 411 with multiple-language display
- PROFIBUS module
- AS-Interface module
- DeviceNet module
- REM module (dynamic brake and control module for electro-mechanical brake)
- EM module (electromechanical brake control module)
- PC connection kit
- Mounting kits for installing the operator panels
- PC startup programs.

#### Note:

The application guidelines or guidelines for the design and operating performance of induction motors with squirrel-cage rotor defined in standards DIN IEC 60034-17 and DIN IEC 60034-25 must be observed for converter-fed induction motors with squirrel-cage rotor.

# IEC Squirrel-Cage Motors

## Motors operating with frequency converters

### Orientation

### Integration (continued)

#### ECOFAST system

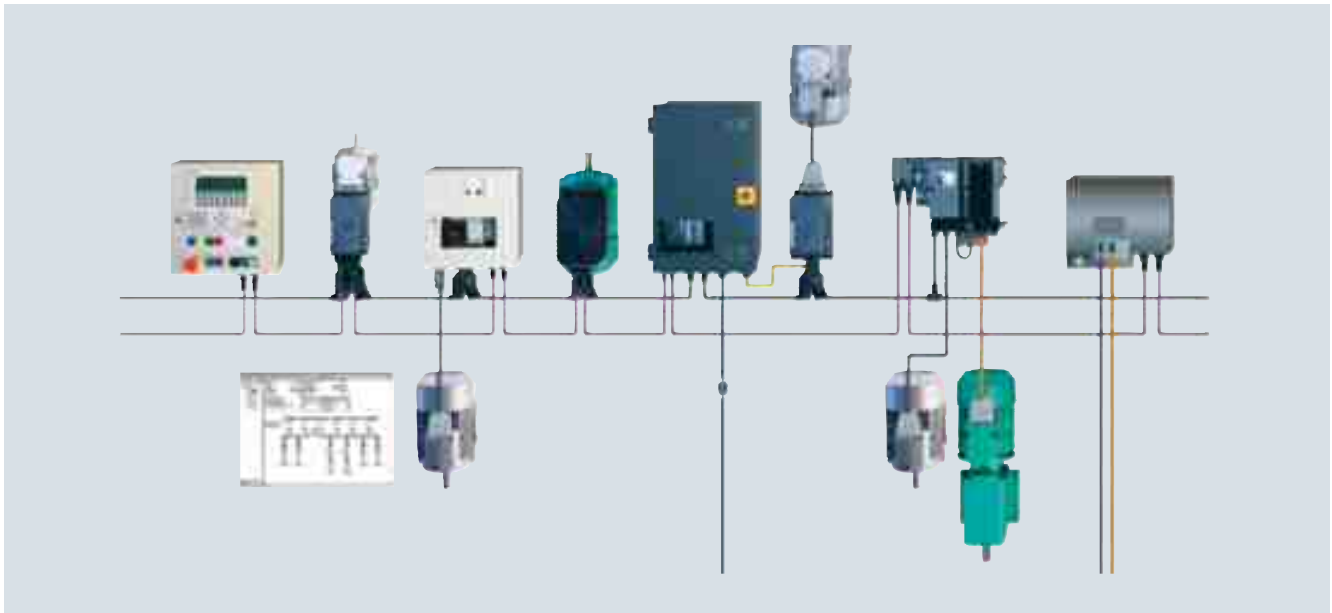

ECOFAST is a system which permits extensive decentralization and a modular structure for installation elements on the component level.

#### Benefits

The main advantages of the ECOFAST motor connector over a terminal strip are as follows:

- Fast assembly of I/O devices (e.g. motor starters) from the ECOFAST system.
- Reduction of assembly and repair times at the end user
- No wiring errors due to connector technology
- Replacement of motor without intervention in the electronics.

#### Main features of the ECOFAST motor connector

The motor connector is mounted in the factory and replaces the connection box with terminal board. The connector is mounted towards the non-drive end (NDE). It comprises an angled motor connection casing that can be rotated by  $4 \times 90^\circ$ . A 10-pole (+ earth) male insert is used in the housing. In the plug-in connector, the winding connections are connected and optionally the power supply for the brake and the signal leads for the temperature sensors.

The ECOFAST motor connector is compatible with the products of the ECOFAST field device system. Further information can be found in Catalog IK PI.

The mounting dimensions of this housing match those of standard industrial connectors, so it is possible to use a complete series of different standard inserts (such as Han E, ES, ESS from Harting). The motor circuit (star or delta connection) is selected in the mating connector for motor connection. The relevant jumpers are inserted by the customer in the mating connector. As a housing for the mating connector, all standard sleeve housing with lengthwise locking, frame size 10B (e.g. from Harting) can be used.

Only one sensor (temperature sensor or PTC thermistor) can be connected.

Maximum admissible mains voltage on motor connector:  $\leq 500$  V

#### Availability of the ECOFAST motor connector

The ECOFAST motor connector can be supplied for the following motor versions with the exception of the explosion-proof motors:

- Frame sizes 56 M to 132 M
- Output range 0.06 to 5.5 kW (7.5 kW on request)
- The rated current of the ECOFAST motor connector is limited to  $\leq 16$  A.
- Direct on-line starting: Voltage code **1** for 230 V $\Delta$ /400 VY, 50 Hz
- Star-delta starting: Voltage code **9** with order code **L1U** for 400 V $\Delta$ , 50 Hz

#### More information

Further information is available in Catalog IK PI and in Catalog DA 51.3 "MICROMASTER 411/COMBIMASTER 411 distributed drive solutions" as well as on the Internet at: <http://www.siemens.com/ecofast>



### Technical specifications

#### General note:

All the data listed in the catalog is applicable for a 50 Hz line supply. With converter-fed operation, the torque reduction factors for constant torque and drives for fans, pumps and compressors must be observed. Higher noise levels must be expected at frequencies other than 50 Hz for motors operating with converters due to the harmonic content of the supply.

#### Implementation of 1LA/1LG motors in areas subject to explosion hazards

##### Type of protection "n" (Zone 2)

II 3G Ex nA II T3  
acc. to IEC/EN 60079-15

IEC/EN 60079-15 specifies that the motor and converter must be tested as a unit (individual test). Individual testing has been performed for motors of type of protection "n" operating with the MICROMASTER, SIMOVERT MASTERDRIVES, SINAMICS G110, SINAMICS S120 and SIMATIC ET 200S FC converters (partially for "Non-standard motors frame size 315" and above). For details, see factory certificate 2.1. Individual testing can be performed for non-Siemens converters on request; the customer may be required to supply the non-Siemens converter.

#### Design for Zone 2 for converter-fed operation, derating Ex nA II T3 acc. to IEC/EN 60079-15 ⇒ Order with order code M73

##### Motors protected against dust explosions (Zone 21/22)

Zone 21: II 2D Ex tD A21 IP65 T 125 °C  
Zone 22: II 3D Ex tD A22 IP55 T 125 °C  
acc. to EN 50281/IEC 61241

The drive system comprising motors protected against dust explosions operating on MICROMASTER, SIMOVERT MASTERDRIVE, SINAMICS G110, SINAMICS S120 and SIMATIC ET 200S FC converters has been tested. For details, see factory certificate 2.1. Please inquire about operation with non-Siemens converters.

#### Design for Zone 21, as well as Zone 22 for conducting dust (IP65) for converter-fed operation, derating ⇒ Order with order code M38

#### Design for Zone 22 for non-conducting dust (IP55) for converter-fed operation, derating ⇒ Order with order code M39

##### Order codes M73, M38 and M39:

The rated operating points at 5, 25, 50 Hz and  $f_{max}$  are stamped on the rating plate; (alternative rated operating points at 6, 30, 60 Hz and  $f_{max}$  when ordered with 60 Hz voltage) for operation on MICROMASTER.

Alternatively, these rated operating points can be ordered for SIMOVERT MASTERDRIVES, SINAMICS G110, SINAMICS S120 or SIMATIC ET 200S FC with order code **Y68** and "Plain text". The type of converter is specified on the rating plate. The motors already have PTC thermistors for tripping in accordance with temperature class 130 (B). The thermistors must be operated by a tripping unit certified by the relevant testing authority.

With some motors it is necessary to reduce the limit speed or to use metal fans.

When 1LA8 motors are ordered, it must be specified in plain text whether "constant torque drive" or "fan/pump/compressor drive" is required.

#### Rated voltage

The tolerance of the motors specially developed for converter-fed operation with special insulation up to 690 V (the 9th and 10th position of the Order No. is marked with "PM") is generally in accordance with DIN EN 60034-1 – A rated voltage range is not specified on the rating plate.

#### Mechanical limit speeds

When the motor is operated at its rated frequency, it is important to note that the maximum speeds are limited by the limits for the roller bearings, critical rotor speed and rigidity of the rotating parts.

#### Motor protection

A motor protection function can be implemented using the  $R^2t$  detection present in the converter software.

If required, more precise motor protection can be afforded by direct temperature measurement using KTY84 sensors or PTC thermistors in the motor winding. Some converters from Siemens determine the motor temperature using the resistance of the temperature sensor. They can be set to a required temperature for alarm and tripping.

#### Insulation

The standard insulation of 1LA and 1LG motors is designed such that converter-fed operation is possible up to 460 V +10 % (for motor serie 1LA8 up to 500 V +10 %). This also applies for operation with a pulse-controlled AC converter with voltage rise times  $t_s > 0.1 \mu s$  at the motor terminals.

All motors with voltage codes 1, 3, 5, and 6 (400 V motors  $\Delta$  connection) operating with a converter must be operated under these conditions. This does not apply to motors with voltages from 500 V to 690 V (+10 %), that must have special insulation for operation on a pulse-controlled AC converter (SIMOVERT MASTERDRIVES and MICROMASTER 440 for voltages between 500 and 600 V), (10th position of the Order No. = "M"). For converter-fed operation with the outputs specified in the catalog, the motors are used according to temperature class 155 (F), i.e. in this case neither a service factor > 1 nor an increased coolant temperature is possible (order codes **C11**, **C12** and **C13** cannot be ordered).

#### Motor connection

When connecting the motors, it is important to consider the restrictions for mains-fed machines as well as the maximum admissible conductor cross-sections for the converter.

#### Ventilation and noise generation

The fan noise can increase at speeds that are higher than the rated speed of self-ventilated motors. To increase motor utilization at low speeds it is recommended that forced ventilated motors are used.

#### Mechanical stress and grease lifetime

Due to the increased speeds above the rated speed and the thereby increased vibrations, the mechanical smooth running is changed and the bearings are used stronger mechanically. Hereby, the grease lifetime and the bearing lifetime are reduced. Further information on request.

#### Utilization (non-standard motors)

When temperature class 155 (F) is used according to 130 (B), derating of 15 % is necessary.

# IEC Squirrel-Cage Motors

## Motors operating with frequency converters

### Orientation

#### Technical specifications (continued)

**Mechanical limit speeds  $n_{\max.}$  at maximum supply frequency  $f_{\max.}$**

Default values

**The values in the following table are valid for all areas of application with the exception of explosion-proof motors (see overleaf).**

The values for motor series 1 LA8, 1PQ8 and 1LL8 are listed in the selection and ordering data in catalog part "Non-standard motors frame size 315 and above".

Motor frame size	Motor type		2-pole <sup>1)</sup>		4-pole		6-pole		8-pole	
			$n_{\max.}$ rpm	$f_{\max.}$ Hz	$n_{\max.}$ rpm	$f_{\max.}$ Hz	$n_{\max.}$ rpm	$f_{\max.}$ Hz	$n_{\max.}$ rpm	$f_{\max.}$ Hz
<b>1LA5, 1LA6, 1LA7, 1LA9, 1LP5, 1LP7, 1PP5, 1PP7</b>										
56 M	<b>1LA7/1LA9</b>	<b>05.</b>	6000	100	4200	140	3600	180	3000	200
63 M	<b>1LA7/1LA9 1LP7/1PP7</b>	<b>06.</b>	6000	100	4200	140	3600	180	3000	200
71 M	<b>1LA7/1LA9 1LP7/1PP7</b>	<b>07.</b>	6000	100	4200	140	3600	180	3000	200
80 M	<b>1LA7/1LA9 1LP7/1PP7</b>	<b>08.</b>	6000	100	4200	140	3600	180	3000	200
90 L	<b>1LA7/1LA9 1LP7/1PP7</b>	<b>09.</b>	6000	100	4200	140	3600	180	3000	200
100 L	<b>1LA6/1LA7/1LA9 1LP7/1PP7/1PP6</b>	<b>10.</b>	6000	100	4200	140	3600	180	3000	200
112 M	<b>1LA6/1LA7/1LA9 1LP7/1PP7/1PP6</b>	<b>11.</b>	6000	100	4200	140	3600	180	3000	200
132 S/M	<b>1LA6/1LA7/1LA9 1LP7/1PP7/1PP6</b>	<b>13.</b>	5600	90	4200	140	3600	180	3000	200
160 M/L	<b>1LA6/1LA7/1LA9 1LP7/1PP7/1PP6</b>	<b>16.</b>	4800	80	4200	140	3600	180	3000	200
180 M/L	<b>1LA5/1LA9 1LP5/1PP5</b>	<b>18.</b>	5100	85	4200	140	3600	180	3000	200
200 L	<b>1LA5/1LA9 1LP5/1PP5</b>	<b>20.</b>	5100	85	4200	140	3600	180	3000	200
225 S/M	<b>1LA5</b>	<b>22.</b>	4500	75	4200	140	3600	180	3000	200
<b>1LG4, 1LG6, 1LP4, 1PP4, 1PP6</b>										
180 M/L	<b>1LG4/1LG6 1LP4/1PP4/1PP6</b>	<b>18.</b>	4600	76	4200	140	3600	180	3000	200
200 L	<b>1LG4/1LG6 1LP4/1PP4/1PP6</b>	<b>20.</b>	4500	75	4200	140	3600	180	3000	200
225 S/M	<b>1LG4/1LG6 1LP4/1PP4/1PP6</b>	<b>22.</b>	4500	75	4500	150	4400	220	4400	293
250 M	<b>1LG4/1LG6 1LP4/1PP4/1PP6</b>	<b>25.</b>	3900	65	3700	123	3700	185	3700	247
280 S/M	<b>1LG4/1LG6 1LP4/1PP4/1PP6</b>	<b>28.</b>	3600	60	3000	100	3000	150	3000	200
315 S	<b>1LG4/1LG6 1LP4/1PP4/1PP6</b>	<b>310</b>	3600	60	2600	87	2600	130	2600	176
315 M	<b>1LG4/1LG6 1LP4/1PP4/1PP6</b>	<b>313</b>	3600	60	2600	87	2600	130	2600	173
315 L	<b>1LG4/1LG6 1LP4/1PP4/1PP6</b>	<b>316 317 318</b>	3600 <sup>2)</sup>	60 <sup>2)</sup>	2600	87	2600	130	2600	173

<sup>1)</sup> Request required for continuous duty in the  $f_{\max.}$  ( $n_{\max.}$ ) range.

<sup>2)</sup> For vertical mounting  $n_{\max.} = 3000$  rpm,  $f_{\max.} = 50$  Hz.

# IEC Squirrel-Cage Motors

## Motors operating with frequency converters

Orientation

### Technical specifications (continued)

#### Explosion-proof motors in Zone 1 with type of protection “de” (motor series 1MJ)

Motor frame size	Motor type	2-pole <sup>1)</sup>		4-pole		6-pole		8-pole		
		$n_{max}$ rpm	$f_{max}$ Hz	$n_{max}$ rpm	$f_{max}$ Hz	$n_{max}$ rpm	$f_{max}$ Hz	$n_{max}$ rpm	$f_{max}$ Hz	
<b>1MJ6</b>										
71 M	<b>1MJ6 07 .</b>	6000	100	3000	100	2000	100	1500	100	
80 M	<b>1MJ6 08 .</b>	6000	100	3000	100	2000	100	1500	100	
90 L	<b>1MJ6 09 .</b>	6000	100	3000	100	2000	100	1500	100	
100 L	<b>1MJ6 10 .</b>	5400	90	3000	100	2000	100	1500	100	
112 M	<b>1MJ6 11 .</b>	5400	90	3000	100	2000	100	1500	100	
132 S/M	<b>1MJ6 13 .</b>	4800	80	3000	100	2000	100	1500	100	
160 M/L	<b>1MJ6 16 .</b>	4500	75	3000	100	2000	100	1500	100	
180 M/L	<b>1MJ6 18 .</b>	5100	85	3000	100	2000	100	1500	100	
200 L	<b>1MJ6 20 .</b>	5100	85	3000	100	2000	100	1500	100	
<b>1MJ7</b>										
225 S/M	<b>1MJ7 22 .</b>	4500	75	3000	100	2000	100	1500	100	
250 M	<b>1MJ7 25 .</b>	3900	65	3700	100	2000	100	1500	100	
280 S	<b>1MJ7 28 .</b>	3600	60	3000	100	2000	100	1500	100	
315 S/M	<b>1MJ7 31 .</b>	3600 <sup>2)</sup>	60 <sup>2)</sup>	2600	87	2000	100	1500	100	

#### Explosion-proof motors in Zone 1 with type of protection “e” (motor series 1MA)

1MA motors cannot be operated with a converter.

#### Explosion-proof motors in Zones 2, 21 and 22 with type of protection “n” or protection against dust explosions (motor series 1LA, 1LG and 1PQ8)

The values for motor series 1LA8 and 1PQ8 in Zones 2 and 22 are listed in the selection and ordering data in catalog part “Non-standard motors frame size 315 and above”.

Motor frame size	Motor type	2-pole <sup>1)</sup>		4-pole		6-pole		8-pole		
		$n_{max}$ rpm	$f_{max}$ Hz	$n_{max}$ rpm	$f_{max}$ Hz	$n_{max}$ rpm	$f_{max}$ Hz	$n_{max}$ rpm	$f_{max}$ Hz	
<b>1LA5, 1LA6, 1LA7, 1LA9</b>										
56 M	<b>1LA7/1LA9 05.</b>	6000	100	3000	100	2000	100	1500	100	
63 M	<b>1LA7/1LA9 06.</b>	6000	100	3000	100	2000	100	1500	100	
71 M	<b>1LA7/1LA9 07.</b>	6000	100	3000	100	2000	100	1500	100	
80 M	<b>1LA7/1LA9 08.</b>	6000	100	3000	100	2000	100	1500	100	
90 L	<b>1LA7/1LA9 09.</b>	6000	100	3000	100	2000	100	1500	100	
100 L	<b>1LA6/1LA7/1LA9 10.</b>	5400	90	3000	100	2000	100	1500	100	
112 M	<b>1LA6/1LA7/1LA9 11.</b>	5400	90	3000	100	2000	100	1500	100	
132 S/M	<b>1LA6/1LA7/1LA9 13.</b>	4800	80	3000	100	2000	100	1500	100	
160 M/L	<b>1LA6/1LA7/1LA9 16.</b>	4500	75	3000	100	2000	100	1500	100	
180 M/L	<b>1LA5/1LA9 18.</b>	5100 <sup>3)</sup>	85 <sup>3)</sup>	3000	100	2000	100	1500	100	
200 L	<b>1LA5/1LA9 20.</b>	5100 <sup>3)</sup>	85 <sup>3)</sup>	3000	100	2000	100	1500	100	
225 S/M	<b>1LA5 22.</b>	5100	85	3000	100	2000	100	1500	100	
<b>1LG4, 1LG6</b>										
180 M/L	<b>1LG4/1LG6 18.</b>	4500	75	3000	100	2000	100	1500	100	
200 L	<b>1LG4/1LG6 20.</b>	4500	75	3000	100	2000	100	1500	100	
225 S/M	<b>1LG4/1LG6 22.</b>	4500	75	3000	100	2000	100	1500	100	
250 M	<b>1LG4/1LG6 25.</b>	3900	65	3000	100	2000	100	1500	100	
280 S/M	<b>1LG4/1LG6 28.</b>	3600	60	3000	100	2000	100	1500	100	
315 S/M/L	<b>1LG4/1LG6 31.</b>	3600 <sup>1)</sup>	60 <sup>1)</sup>	2600	87	2000	100	1500	100	

<sup>1)</sup> Request required for continuous duty in the  $f_{max}$ , ( $n_{max}$ ) range.

<sup>2)</sup> For vertical mounting  $n_{max}$  = 3000 rpm,  $f_{max}$  = 50 Hz.

<sup>3)</sup> For 1LA9 motors frame sizes 180 M/L and 200 L,  $n_{max}$  = 4500 rpm and  $f_{max}$  = 75 Hz.

# IEC Squirrel-Cage Motors

## Motors operating with frequency converters

### Orientation

#### Technical specifications (continued)

##### Bearings and bearing currents

When operating multiphase induction machines on a converter, an electrical bearing stress results from a capacitive induced voltage via the bearing lubricating film, depending on the principle being used. The physical cause of this is the common-mode voltage at the converter output. The sum of the three phase-to-neutral voltages is not zero at all times, unlike with direct on-line operation. The high-frequency, pulse-shaped common-mode voltage brings about a residual current, which closes back to the converter's DC link via the machine's internal capacitances, the machine housing and the earthing circuit. The machine's internal capacitances include the main insulation winding capacitance, the geometric capacitance between the rotor and stator, the lubricating film capacitance and the capacitance of any bearing insulation that may be present. The current level via the internal capacitances is proportional to the common-mode voltage regulation ( $i_{(t)} = C \cdot du/dt$ ).

In order to apply currents to the motor which are sinusoidal as far as possible (smooth running, oscillation torques, stray losses), a high clock frequency is required for the converter's output voltage. The related (very steep) switching edges of the converter output voltage (and also, therefore, of the common-mode voltage) cause correspondingly high capacitive currents and voltages on the machine's internal capacitances.

In the worst-case scenario, the capacitive voltage induced via the bearing can lead to random punctures of the bearing lubricating film, thus damaging the bearing/causing premature wear. The current pulses caused by the puncture in the lubricating film are referred to as EDM (Electrostatic Discharge Machining) currents, although this is not primarily a question of an electrostatic effect, but more of (partial) punctures of insulating material, i.e., of partial discharges.

This physical effect, which occurs in isolated cases, has mostly been observed in connection with larger motors.

EMC-compliant installation of the drive system is a basic prerequisite for preventing premature bearing damage via bearing currents.

The most important measures for reducing bearing currents:

- Insulated motor bearings at the non-drive end NDE  
The insulated bearing is standard for all non-standard 1LA8 motors designated for converter operation. Furthermore it is recommended that an insulated bearing is ordered for NDE for motor series 1LG, 1PP4, 1LP4 and 1MJ7 frame size 225 and above (order code **L27**).
- Hybrid bearings with ceramic bearing elements on drive end (DE) and non-drive end (NDE)
- Earthing brush for converter-fed operation for 1LG motors (order code **M44**)
- Use of cables with a symmetrical cable cross-section:

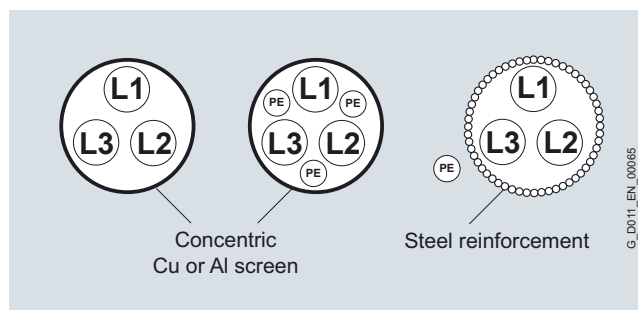

- Use of motor reactors
- Use of earthing cables with low impedance in a large frequency range (0 Hz up to approximately 70 MHz): for example, plaited copper ribbon cables, HF litz wires
- Separate HF equipotential-bonding cable between motor housing and driven machine
- Separate HF equipotential-bonding cable between motor housing and converter PE busbar
- 360° HF contacting of the cable shield on the motor housing and the converter PE busbar. This can be achieved using EMC screwed glands on the motor end and EMC shield clips on the converter end, for example.
- Common-mode filters at the converter output (e.g. nanoperm rings).

The given measures can be required for motor series 1LA5 frame size 225 and 1LG frame size 225 and above depending on the application with converter-fed operation and are therefore recommend.

# IEC Squirrel-Cage Motors

## Motors operating with frequency converters

Orientation

### Selection and ordering data

*Preliminary selection of the motor according to motor type/series, speed or number of poles, frame size, rated output, rated torque, rated speed and rated current*

Surface-cooled motors with standard insulation for voltages ≤500 V – Aluminum or cast-iron housing

See section “Surface-cooled motors with standard insulation for voltages ≤500 V – Aluminum or cast-iron housing” Pages 5/10 and 5/11.

Self-ventilated motors with special insulation for voltages up to 690 V

Speed	Frame size	Rated output	Rated speed	Rated torque	Rated current at 690 V	Detailed selection and ordering data
rpm		kW	rpm	Nm	A	Page
<b>Aluminum series 1LA7 and 1LA5</b>						
<b>3000, 2-pole</b>	<b>100 L ... 225 M</b>	3 ... 45	2890 ... 2960	9.9 ... 145	3.5 ... 45.0	<b>5/12 ... 5/13</b>
<b>1500, 4-pole</b>	<b>100 L ... 225 S</b>	2.2 ... 37	1420 ... 1470	15 ... 240	2.75 ... 38.5	<b>5/12 ... 5/13</b>
<b>1000, 6-pole</b>	<b>100 L ... 225 M</b>	1.5 ... 30	925 ... 978	15 ... 293	2.25 ... 35.5	<b>5/12 ... 5/13</b>
<b>Cast-iron series 1LG6</b>						
<b>3000, 2-pole</b>	<b>180 M ... 315 L</b>	22 ... 200	2955 ... 2982	71 ... 641	22.5 ... 188	<b>5/14 ... 5/16</b>
<b>1500, 4-pole</b>	<b>180 M ... 315 L</b>	18.5 ... 200	1470 ... 1490	120 ... 1282	20 ... 198	<b>5/14 ... 5/16</b>
<b>1000, 6-pole</b>	<b>180 L ... 315 L</b>	15 ... 160	975 ... 990	147 ... 1543	17.2 ... 164	<b>5/14 ... 5/16</b>
<b>750, 8-pole</b>	<b>180 L ... 315 L</b>	11 ... 132	725 ... 740	145 ... 1704	13.8 ... 140	<b>5/14 ... 5/16</b>
<b>Cast-iron series 1LA8</b>						
<b>3000, 2-pole</b>	<b>315 ... 450</b>	240 ... 970	2978 ... 2987	770 ... 3101	730 ... 900	<b>3/18 ... 3/19</b>
<b>1500, 4-pole</b>	<b>315 ... 450</b>	235 ... 980	1485 ... 1492	1511 ... 6273	235 ... 950	<b>3/18 ... 3/19</b>
<b>1000, 6-pole</b>	<b>315 ... 450</b>	190 ... 780	990 ... 993	1833 ... 7502	196 ... 790	<b>3/20 ... 3/21</b>
<b>750, 8-pole</b>	<b>315 ... 450</b>	145 ... 600	740 ... 745	1871 ... 7691	162 ... 660	<b>3/20 ... 3/21</b>

Forced ventilated motors with mounted separately driven fan with special insulation for voltages up to 690 V

Speed	Frame size	Rated output	Rated speed	Rated torque	Rated current at 690 V	Detailed selection and ordering data
rpm		kW	rpm	Nm	A	Page
<b>Cast-iron series 1PQ8</b>						
<b>3000, 2-pole</b>	<b>315 ... 450</b>	240 ... 970	2978 ... 2987	770 ... 3101	730 ... 900	<b>3/26 ... 3/27</b>
<b>1500, 4-pole</b>	<b>315 ... 450</b>	235 ... 980	1485 ... 1492	1511 ... 6273	235 ... 950	<b>3/26 ... 3/27</b>
<b>1000, 6-pole</b>	<b>315 ... 450</b>	190 ... 780	990 ... 993	1833 ... 7502	196 ... 790	<b>3/28 ... 3/29</b>
<b>750, 8-pole</b>	<b>315 ... 450</b>	145 ... 600	740 ... 745	1871 ... 7691	162 ... 660	<b>3/28 ... 3/29</b>

### More information

Planning notes for drives with constant and square-law torque can be found in the following catalogs:

- Frequency converters – MICROMASTER 420/430/440: Catalog DA 51.2
- Frequency converters for distributed drive solutions – MICROMASTER 411/COMBIMASTER 411: Catalog DA 51.3
- SIMOVERT MASTERDRIVES Motion Control/Vector Control: Catalog series DA 65
- SINAMICS G130 and G150 frequency converters: Catalog series D 11
- Frequency converters SINAMICS G110, SINAMICS G120 and SINAMICS G120 D: Catalog D11.1
- SINAMICS S120 and S150 drive systems: Catalog series D 21

These catalogs contain tables that specify the assignment of squirrel-cage motors to converters from Siemens in accordance with the load characteristic of the driven machine.

For further information, please contact your local Siemens contact – see “Siemens Contacts Worldwide” in the Appendix.

# IEC Squirrel-Cage Motors

## Motors operating with frequency converters

Surface-cooled motors with standard insulation  
up to 500 V – Aluminum or cast-iron housing

### Overview

#### Standard motors up to frame size 315 L

The standard motors from Siemens are suitable for converter-fed operation at rated voltages up to 460 V. The following table shows the available motor series:

#### Standard motors up to frame size 315 L for converter-fed operation up to 460 V rated voltage

Motor type	Standard type of protection	Frame design	Motor series	Motor frame sizes	Output range kW
Self-ventilated motors with improved efficiency (energy-saving motors according to efficiency class EFF2 Improved Efficiency for 2-pole and 4-pole motors with outputs from 1.1 to 90 kW)	IP55	Aluminum	<b>1LA7</b>	56 M ... 160 L	0.06 ... 18.5
			<b>1LA5</b>	180 M ... 225 M	11 ... 45
		Cast-iron	<b>1LA6</b>	100 L ... 160 L	0.75 ... 18.5
			<b>1LG4</b>	180 M ... 315 L	11 ... 200
Self-ventilated motors with high efficiency (energy-saving motors according to efficiency class EFF1 High Efficiency for 2-pole and 4-pole motors with outputs from 1.1 to 90 kW)	IP55	Aluminum	<b>1LA9</b>	56 M ... 200 L	0.06 ... 37
		Cast-iron	<b>1LG6</b>	180 M ... 315 L	11 ... 200
Self-ventilated motors with increased output	IP55	Aluminum	<b>1LA9</b>	56 M ... 200 L	0.14 ... 53
		Cast-iron	<b>1LG4</b>	180 M ... 280 M	15 ... 110
Self-cooled motors without external fan	IP55	Aluminum	<b>1LP7</b>	63 M ... 160 L	0.045 ... 7
			<b>1LP5</b>	180 M ... 200 L	5.5 ... 16.5
		Cast-iron	<b>1LP4</b>	180 L ... 315 L	3.7 ... 67
Pole-changing motors	IP55	Aluminum	<b>1LA7</b>	63 M ... 160 L	0.1 ... 17
			<b>1LA5</b>	180 M ... 200 L	11 ... 31

For technical data, selection and ordering data and special versions, see the relevant sections of "Standard motors up to frame size 315 L".

## 5

#### Non-standard motors frame size 315 and above

The non-standard motors from Siemens are suitable for converter-fed operation at rated voltages up to 500 V. The following table shows the available motor series:

#### Non-standard motors up to frame size 315 for converter-fed operation up to 500 V rated voltage

Motor type	Standard type of protection	Frame design	Motor series	Motor frame sizes	Output range kW
Self-ventilated motors for converter-fed operation – Cast-iron series 1LA8	IP55	Cast-iron	<b>1LA8</b>	315 ... 450	145 ... 1000
Forced ventilated motors with mounted separately driven fan for converter-fed operation – Cast-iron series 1PQ8	IP55	Cast-iron	<b>1PQ8</b>	315 ... 450	145 ... 1000
Self-ventilated motors with through ventilation for converter-fed operation – Cast-iron series 1LL8	IP23	Cast-iron	<b>1LL8</b>	315 ... 450	200 ... 1250

For technical data, selection and ordering data and special versions, see the relevant sections of "Non-standard motors up to frame size 315".

# IEC Squirrel-Cage Motors

## Motors operating with frequency converters

Surface-cooled motors with standard insulation  
up to 500 V – Aluminum or cast-iron housing

### Overview (continued)

#### Explosion-proof motors

The explosion-proof motors from Siemens listed below up to frame size 315 L can be operated with a converter at rated voltages up to 460 V (for motor series 1LA8 and 1PQ8 up to 500 V):

Explosion-proof motors up to frame size 315 L for converter-fed operation up to 460 V (for motor series 1LA8 and 1PQ8 up to 500 V) rated voltage

Motor type	Standard type of protection	Frame design	Motor series <sup>1)</sup>	Motor frame sizes	Output range
					kW
Self-ventilated motors in Zone 1 with type of protection "d" (Zone 1 Exde IIC T4)	IP55	Cast-iron	<b>1MJ6</b>	71 M ... 200 L	0.25 ... 37
			<b>1MJ7</b>	225 M ... 315 L	30 ... 132
Self-ventilated motors in Zone 2 with type of protection "n" or protection against dust explosions	IP55	Aluminum	<b>1LA7</b>	63 M ... 160 L	0.09 ... 18.5
		Cast-iron	<b>1LA9</b>	56 M ... 200 L	0.06 ... 37
			<b>1LA6</b>	100 L ... 160 L	0.75 ... 18.5
			<b>1LG4/1LG6</b>	180 M ... 315 L	11 ... 200
Self-ventilated motors in Zone 21 with type of protection "n" or protection against dust explosions	IP55	Aluminum	<b>1LA7</b>	56 M ... 160 L	0.09 ... 18.5
		Cast-iron	<b>1LA5</b>	180 M ... 225 M	11 ... 45
			<b>1LA9</b>	56 M ... 200 L	0.06 ... 37
			<b>1LG4/1LG6</b>	180 M ... 315 L	11 ... 200
Self-ventilated motors in Zone 22 with type of protection "n" or protection against dust explosions	IP55	Aluminum	<b>1LA7</b>	56 M ... 160 L	0.09 ... 18.5
		Cast-iron	<b>1LA5</b>	180 M ... 225 M	11 ... 45
			<b>1LA9</b>	56 M ... 200 L	0.06 ... 37
			<b>1LA6</b>	100 L ... 160 L	0.75 ... 18.5
Self-ventilated motors in Zones 2 and 22 with type of protection "n" or protection against dust explosions	IP55	Cast-iron	<b>1LA8</b>	315 ... 450	145 ... 1000
			<b>1PQ8</b>	315 ... 450	145 ... 1000

For technical data, selection and ordering data and special versions, see the relevant sections of "Explosion-proof motors".

#### Fan motors

The fan motors from Siemens listed below are suitable for converter-fed operation at rated voltages up to 460 V :

Fan motors for converter-fed operation at 460 V rated voltage

Motor type	Standard degree of protection	Frame design	Motor series	Motor frame sizes	Output range
					kW
Self-ventilated motors in pole-changing version	IP55	Aluminum	<b>1LA7</b>	80 M ... 160 L	0.15 ... 17
			<b>1LA5</b>	180 M ... 200 L	18 ... 31
		Cast-iron	<b>1LG4</b>	180 M ... 315 L	11 ... 200
Forced-air cooled motors without external fan and fan cover	IP55	Aluminum	<b>1PP7</b>	63 M ... 160 L	0.09 ... 18.5
			<b>1PP5</b>	180 M ... 200 L	15 ... 37
		Cast-iron	<b>1PP4</b>	180 M ... 315 L	11 ... 200

For technical data, selection and ordering data and special versions, see the relevant sections of "Fan motors".

<sup>1)</sup> For converter-fed operation with frame size 225 and above, it is recommended that an "Insulated bearing cartridge" – order code **L27** – is used. For motor series 1LA8 and 1PQ8, the insulated bearing cartridge is standard.

# IEC Squirrel-Cage Motors

## Motors operating with frequency converters

**Self-ventilated motors with special insulation up to 690 V – Aluminum series 1LA7 and 1LA5**

### Selection and ordering data

Rated output at 50 Hz $P_{rated}$ kW	Frame size FS	Operating values at rated output								Order No. For Order No. supplements for voltage and type of construction, see table below	Price	Weight Type of construction IM B3 approx. $m$ kg
		Rated speed at 50 Hz $n_{rated}$ rpm	Rated torque at 50 Hz $T_{rated}$ Nm	Efficiency at 50 Hz 4/4-load $\eta_{rated}$ %	Efficiency at 50 Hz 3/4-load $\eta_{rated}$ %	Power factor at 50 Hz 4/4-load $\cos\phi_{rated}$	Power factor at 50 Hz 3/4-load $\cos\phi_{rated}$	Rated current at 400 V, 50 Hz $I_{rated}$ A	Rated current at 690 V, 50 Hz $I_{rated}$ A			
<b>2-pole, 3000 rpm at 50 Hz, temperature class 155 (F), IP55 degree of protection, specially for operation on SIMOVERT MASTERDRIVES</b>												
3	100 L	2890	9.9	84	84	0.85	0.81	6.1	3.5	1LA7 106-2PM00	21	
4	112 M	2905	13	86	86	0.86	0.83	7.8	4.55	1LA7 113-2PM00	27	
5.5	132 S	2925	18	86.5	86.5	0.89	0.86	10.4	6	1LA7 130-2PM00	37	
7.5	132 S	2930	24	88	88	0.89	0.86	13.8	8	1LA7 131-2PM00	42	
11	160 M	2930	36	89.5	89.5	0.88	0.85	20	11.6	1LA7 163-2PM00	63	
15	160 M	2940	49	90	90.2	0.9	0.88	26.5	15.4	1LA7 164-2PM00	72	
18.5	160 L	2940	60	91	91.2	0.91	0.89	32	18.6	1LA7 166-2PM00	82	
22	180 M	2940	71	91.7	91.7	0.88	0.85	31.5	23	1LA5 183-2PM00	113	
30	200 L	2945	97	92.3	92.3	0.89	0.86	53	30.5	1LA5 206-2PM00	159	
37	200 L	2945	120	92.8	92.8	0.89	0.86	65	37.5	1LA5 207-2PM00	179	
45	225 M	2960	145	93.6	93.6	0.89	0.86	78	45	1LA5 223-2PM00	209	
<b>4-pole, 1500 rpm at 50 Hz, temperature class 155 (F), IP55 degree of protection, specially for operation on SIMOVERT MASTERDRIVES</b>												
2.2	100 L	1420	15	82	82.5	0.82	0.77	4.7	2.75	1LA7 106-4PM00	20	
3	100 L	1420	20	82.6	82.6	0.82	0.77	6.4	3.7	1LA7 107-4PM00	23	
4	112 M	1440	27	85	85.5	0.83	0.79	8.2	4.75	1LA7 113-4PM00	29	
5.5	132 S	1455	36	86	86	0.81	0.76	11.4	6.6	1LA7 130-4PM00	39	
7.5	132 M	1455	49	87	87.5	0.82	0.77	15.2	8.8	1LA7 133-4PM00	46	
11	160 M	1460	72	88.5	89	0.84	0.8	21.5	12.4	1LA7 163-4PM00	67	
15	160 L	1460	98	90	90.2	0.84	0.8	28.5	16.6	1LA7 166-4PM00	81	
18.5	180 M	1460	121	90.5	90.5	0.83	0.79	35.5	20.5	1LA5 183-4PM00	113	
22	180 L	1460	144	91.2	91.2	0.84	0.8	41.5	24	1LA5 186-4PM00	123	
30	200 L	1465	196	91.8	91.8	0.86	0.83	55	32	1LA5 207-4PM00	157	
37	225 S	1470	240	92.9	92.9	0.87	0.84	66	38.5	1LA5 220-4PM00	206	
45	225 M	1470	292	93.4	93.4	0.87	0.84	80	46.5	1LA5 223-4PM00	232	
<b>6-pole, 1000 rpm at 50 Hz, temperature class 155 (F), IP55 degree of protection, specially for operation on SIMOVERT MASTERDRIVES</b>												
1.5	100 L	925	15	74	74	0.75	0.69	3.9	2.25	1LA7 106-6PM00	20	
2.2	112 M	940	22	78	78.5	0.78	0.72	5.2	3.05	1LA7 113-6PM00	24	
3	132 S	950	30	79	79.5	0.76	0.7	7.2	4.2	1LA7 130-6PM00	34	
4	132 M	950	40	80.5	80.5	0.76	0.7	9.4	5.5	1LA7 133-6PM00	41	
5.5	132 M	950	55	83	83	0.76	0.7	12.6	7.3	1LA7 134-6PM00	50	
7.5	160 M	960	75	86	86	0.74	0.68	17	9.9	1LA7 163-6PM00	70	
11	160 L	960	109	87.5	87.5	0.74	0.68	24.5	14.2	1LA7 166-6PM00	89	
15	180 L	970	148	89.5	89.5	0.77	0.71	31.5	18.2	1LA5 186-6PM00	126	
18.5	200 L	975	181	90.2	90.2	0.77	0.71	38.5	22.5	1LA5 206-6PM00	161	
22	200 L	975	215	90.8	90.8	0.77	0.71	45.5	26.5	1LA5 207-6PM00	183	
30	225 M	978	293	91.8	91.8	0.77	0.71	61	35.5	1LA5 223-6PM00	214	

### Order No. supplements

Motor type	Penultimate position: Voltage code			Final position: Type of construction code						
	50 Hz			Without flange			With flange		With standard flange	
	500 VY	500 VΔ	690 VY	IM B3/6/7/8, IM V6, IM V5 without protective cover	IM B5, IM V1 without protective cover <sup>1)</sup> , IM V3	IM V1 with protective cover <sup>1) 2)</sup>	IM B35	IM B14, IM V18 without protective cover, IM V19	IM B34	IM B14, IM V18 without protective cover, IM V19
	3	5	8	0	1	4	6	2	7	3
1LA7 10 . . . . . 00	○	○	○	□	✓	✓	✓	✓	✓	✓
1LA7 11 . . . . . 00	○	○	○	□	✓	✓	✓	✓	✓	✓
1LA7 13 . . . . . 00	○	○	○	□	✓	✓	✓	✓	✓	✓
1LA7 16 . . . . . 00	○	○	○	□	✓	✓	✓	✓	✓	✓
1LA5 18 . . . . . 00	○	○	○	□	✓ <sup>3)</sup>	✓	✓	-	-	-
1LA5 20 . . . . . 00	○	○	○	□	✓ <sup>3)</sup>	✓	✓	-	-	-
1LA5 22 . . . . . 00	○	○	○	□	✓ <sup>3)</sup>	✓	✓	-	-	-

Standard version  
 Without additional charge  
 With additional charge  
 Not possible

For additional text and footnotes, see Page 5/13.



# IEC Squirrel-Cage Motors

## Motors operating with frequency converters

Self-ventilated motors with special insulation  
up to 690 V – Aluminum series 1LA7 and 1LA5

### Selection and ordering data (continued)

Order No.	Locked-rotor torque with direct starting torque $T_{LR}/T_{rated}$	Locked-rotor current as multiple of rated current $I_{LR}/I_{rated}$	Breakdown torque torque $T_B/T_{rated}$	Torque class CL	Moment of inertia $J$ kgm <sup>2</sup>	Noise rated output Measuring surface sound pressure level at 50 Hz $L_{p(A)}$ dB(A)	Sound pressure level at 50 Hz $L_{WA}$ dB(A)
<b>2-pole, 3000 rpm at 50 Hz, temperature class 155 (F), IP55 degree of protection, specially for operation on SIMOVERT MASTERDRIVES</b>							
1LA7 106-2PM□□	2.8	6.8	3	16	0.0035	62	74
1LA7 113-2PM□□	2.6	7.2	2.9	16	0.0059	63	75
1LA7 130-2PM□□	2	5.9	2.8	16	0.015	68	80
1LA7 131-2PM□□	2.3	6.9	3	16	0.019	68	80
1LA7 163-2PM□□	2.1	6.5	2.9	16	0.034	70	82
1LA7 164-2PM□□	2.2	6.6	3	16	0.043	70	82
1LA7 166-2PM□□	2.4	7	3.1	16	0.051	70	82
1LA5 183-2PM□□	2.5	6.9	3.2	16	0.077	70	83
1LA5 206-2PM□□	2.4	7.2	2.8	16	0.14	71	84
1LA5 207-2PM□□	2.4	7.7	2.8	16	0.16	71	84
1LA5 223-2PM□□	2.8	7.7	3.4	16	0.2	71	84
<b>4-pole, 1500 rpm at 50 Hz, temperature class 155 (F), IP55 degree of protection, specially for operation on SIMOVERT MASTERDRIVES</b>							
1LA7 106-4PM□□	2.5	5.6	2.8	16	0.0047	53	65
1LA7 107-4PM□□	2.7	5.6	3	16	0.0055	53	65
1LA7 113-4PM□□	2.7	6	3	16	0.012	53	65
1LA7 130-4PM□□	2.5	6.3	3.1	16	0.018	62	74
1LA7 133-4PM□□	2.7	6.7	3.2	16	0.023	62	74
1LA7 163-4PM□□	2.2	6.2	2.7	16	0.043	66	78
1LA7 166-4PM□□	2.6	6.5	3	16	0.055	66	78
1LA5 183-4PM□□	2.3	7.5	3	16	0.13	63	76
1LA5 186-4PM□□	2.3	7.5	3	16	0.15	63	76
1LA5 207-4PM□□	2.6	7	3.2	16	0.24	65	78
1LA5 220-4PM□□	2.8	7	3.2	16	0.32	65	78
1LA5 223-4PM□□	2.8	7.7	3.3	16	0.36	65	78
<b>6-pole, 1000 rpm at 50 Hz, temperature class 155 (F), IP55 degree of protection, specially for operation on SIMOVERT MASTERDRIVES</b>							
1LA7 106-6PM□□	2.3	4	2.3	16	0.0047	47	59
1LA7 113-6PM□□	2.2	4.6	2.5	16	0.0091	52	64
1LA7 130-6PM□□	1.9	4.2	2.2	16	0.015	63	75
1LA7 133-6PM□□	2.1	4.5	2.4	16	0.019	63	75
1LA7 134-6PM□□	2.3	5	2.6	16	0.025	63	75
1LA7 163-6PM□□	2.1	4.6	2.5	16	0.044	66	78
1LA7 166-6PM□□	2.3	4.8	2.6	16	0.063	66	78
1LA5 186-6PM□□	2	5.2	2.4	16	0.15	66	78
1LA5 206-6PM□□	2.7	5.5	2.8	16	0.24	66	78
1LA5 207-6PM□□	2.8	5.5	2.9	16	0.28	66	78
1LA5 223-6PM□□	2.8	5.7	2.9	16	0.36	66	78

Order other voltages with voltage code **9** in the penultimate position and the corresponding order code (see "Special versions" in the "Selection and ordering data" under "Voltages").

Order other types of construction with type of construction code **9** in the final position and the corresponding order code (see "Special versions" in the "Selection and ordering data" under "Types of construction").

- For type of construction IM V1 with/without protective cover, motors 1LA5 183-... to 1LA5 223-... (motor series 1LA5 frame sizes 180 M to 225 M) can be supplied with two additional eyebolts. Specify order supplement **"Z"** and order code **K32**.
- The "Second shaft extension" option, order code **K16** is not possible.
- Type of construction IM V3 can only be ordered using type of construction code **9** and order code **M1G**.

# IEC Squirrel-Cage Motors

## Motors operating with frequency converters

Self-ventilated motors with special insulation  
up to 690 V – Cast-iron series 1LG6

### Selection and ordering data

Rated output at 50 Hz	Frame size	Operating values at rated output								Order No.	Price	Weight
		Rated speed at 50 Hz	Rated torque at 50 Hz	Efficiency at 50 Hz 4/4-load	Efficiency at 50 Hz 3/4-load	Power factor at 50 Hz 4/4-load	Power factor at 50 Hz 3/4-load	Rated current at 400 V, 50 Hz	Rated current at 690 V, 50 Hz			
$P_{\text{rated}}$ kW	FS	$n_{\text{rated}}$ rpm	$T_{\text{rated}}$ Nm	$\eta_{\text{rated}}$ %	$\eta_{\text{rated}}$ %	$\cos\phi_{\text{rated}}$	$\cos\phi_{\text{rated}}$	$I_{\text{rated}}$ A	$I_{\text{rated}}$ A			Type of construction IM B3 approx. m kg
<b>2-pole, 3000 rpm at 50 Hz, temperature class 155 (F), IP55 degree of protection, specially for operation on SIMOVERT MASTERDRIVES</b>												
22	180 M	2955	71	93.7	94.1	0.88	0.85	38.5	22.5	1LG6 183-2PM00		180
30	200 L	2960	97	93.1	93	0.89	0.85	53	30.5	1LG6 206-2PM00		225
37	200 L	2960	119	93.6	93.5	0.89	0.86	64	37	1LG6 207-2PM00		255
45	225 M	2965	145	94.4	94.6	0.89	0.87	77	45	1LG6 223-2PM00 <sup>1)</sup>		330
55	250 M	2975	177	95	95	0.9	0.88	93	54	1LG6 253-2PM00 <sup>1)</sup>		420
75	280 S	2975	241	95	95	0.89	0.87	128	74	1LG6 280-2PM00 <sup>1)</sup>		530
90	280 M	2978	289	95.3	95.4	0.9	0.88	150	88	1LG6 283-2PM00 <sup>1)</sup>		615
110	315 S	2982	352	95.5	95.4	0.91	0.89	182	106	1LG6 310-2PM00 <sup>1)</sup>		790
132	315 M	2982	423	95.8	95.7	0.91	0.91	220	126	1LG6 313-2PM00 <sup>1)</sup>		915
160	315 L	2982	512	96.2	96.2	0.92	0.91	260	152	1LG6 316-2PM00 <sup>1)</sup>		1055
200	315 L	2982	641	96.2	96.2	0.93	0.92	320	188	1LG6 317-2PM00 <sup>1)</sup>		1245
<b>4-pole, 1500 rpm at 50 Hz, temperature class 155 (F), IP55 degree of protection, specially for operation on SIMOVERT MASTERDRIVES</b>												
18.5	180 M	1470	120	92.1	92.7	0.83	0.78	34.5	20	1LG6 183-4PM00		155
22	180 L	1470	143	92.7	93	0.84	0.79	40.5	23.5	1LG6 186-4PM00		180
30	200 L	1470	195	92.7	92.8	0.85	0.8	55	32	1LG6 207-4PM00		225
37	225 S	1480	239	93.6	94	0.85	0.81	67	39	1LG6 220-4PM00 <sup>1)</sup>		290
45	225 M	1480	290	94.1	94.3	0.85	0.82	81	47	1LG6 223-4PM00 <sup>1)</sup>		330
55	250 M	1485	354	94.8	95	0.87	0.83	96	56	1LG6 253-4PM00 <sup>1)</sup>		460
75	280 S	1485	482	94.7	94.8	0.87	0.84	130	76	1LG6 280-4PM00 <sup>1)</sup>		575
90	280 M	1486	578	95.1	95.2	0.86	0.83	158	92	1LG6 283-4PM00 <sup>1)</sup>		675
110	315 S	1488	706	95.6	95.7	0.87	0.84	190	110	1LG6 310-4PM00 <sup>1)</sup>		810
132	315 M	1488	847	95.9	96	0.88	0.85	225	130	1LG6 313-4PM00 <sup>1)</sup>		965
160	315 L	1490	1026	96.1	96.2	0.88	0.85	275	158	1LG6 316-4PM00 <sup>1)</sup>		1105
200	315 L	1490	1282	96.1	96.2	0.88	0.86	340	198	1LG6 317-4PM00 <sup>1)</sup>		1305
<b>6-pole, 1000 rpm at 50 Hz, temperature class 155 (F), IP55 degree of protection, specially for operation on SIMOVERT MASTERDRIVES</b>												
15	180 L	975	147	90	90.8	0.81	0.77	29.5	17.2	1LG6 186-6PM00		175
18.5	200 L	978	181	90.5	91.1	0.81	0.76	36	21	1LG6 206-6PM00		210
22	200 L	978	215	91.4	92	0.82	0.78	42	24.5	1LG6 207-6PM00		240
30	225 M	980	292	92.6	93.1	0.83	0.8	56	32.5	1LG6 223-6PM00 <sup>1)</sup>		325
37	250 M	985	359	93.1	93.5	0.83	0.79	69	40	1LG6 253-6PM00 <sup>1)</sup>		405
45	280 S	988	435	93.9	94.1	0.85	0.81	81	47	1LG6 280-6PM00 <sup>1)</sup>		520
55	280 M	988	532	93.9	94.1	0.85	0.81	99	58	1LG6 283-6PM00 <sup>1)</sup>		570
75	315 S	990	723	94.6	94.6	0.83	0.79	138	80	1LG6 310-6PM00 <sup>1)</sup>		760
90	315 M	990	868	94.9	95	0.85	0.81	160	93	1LG6 313-6PM00 <sup>1)</sup>		935
110	315 L	990	1061	95.2	95.3	0.85	0.82	196	114	1LG6 316-6PM00 <sup>1)</sup>		1010
132	315 L	990	1273	95.4	95.4	0.85	0.82	235	136	1LG6 317-6PM00 <sup>1)</sup>		1180
160	315 L	990	1543	95.3	95.4	0.86	0.82	280	164	1LG6 318-6PM00 <sup>1)</sup>		1245
<b>8-pole, 750 rpm at 50 Hz, temperature class 155 (F), IP55 degree of protection, specially for operation on SIMOVERT MASTERDRIVES</b>												
11	180 L	725	145	88.1	89	0.76	0.69	23.5	13.8	1LG6 186-8PM00		165
15	200 L	725	198	88.2	88.7	0.8	0.73	30.5	17.8	1LG6 207-8PM00		235
18.5	225 S	730	242	89.9	90.6	0.81	0.75	36	21.5	1LG6 220-8PM00 <sup>1)</sup>		295
22	225 M	730	288	90.6	91.1	0.81	0.75	43	25	1LG6 223-8PM00 <sup>1)</sup>		335
30	250 M	735	390	91.9	92.4	0.82	0.77	57	33.5	1LG6 253-8PM00 <sup>1)</sup>		435
37	280 S	738	479	92.6	92.8	0.81	0.76	71	41.5	1LG6 280-8PM00 <sup>1)</sup>		510
45	280 M	738	582	93.3	93.6	0.81	0.77	86	50	1LG6 283-8PM00 <sup>1)</sup>		560
55	315 S	740	710	93.8	93.9	0.82	0.77	102	60	1LG6 310-8PM00 <sup>1)</sup>		750
75	315 M	740	968	93.9	94.1	0.83	0.78	138	81	1LG6 313-8PM00 <sup>1)</sup>		840
90	315 L	740	1161	94.2	94.6	0.84	0.8	164	95	1LG6 316-8PM00 <sup>1)</sup>		1005
110	315 L	740	1420	94.3	94.6	0.84	0.79	200	116	1LG6 317-8PM00 <sup>1)</sup>		1100
132	315 L	740	1704	94.4	94.7	0.84	0.8	240	140	1LG6 318-8PM00 <sup>1)</sup>		1270

For Order No. supplement, see Page 5/16.

<sup>1)</sup> Insulated bearing cartridge at non-drive-end NDE is recommended (order code L27).

# IEC Squirrel-Cage Motors

## Motors operating with frequency converters

Self-ventilated motors with special insulation  
up to 690 V – Cast-iron series 1LG6

### Selection and ordering data (continued)

Order No.	Locked-rotor torque with direct starting torque	Locked-rotor current as multiple of rated current	Breakdown torque torque	Torque class	Moment of inertia	Noise at rated output Measuring surface sound pressure level at 50 Hz	Sound pressure level at 50 Hz
	$T_{LR}/T_{rated}$	$I_{LR}/I_{rated}$	$T_B/T_{rated}$	CL	$J$ kgm <sup>2</sup>	$L_{p(A)}$ dB(A)	$L_{WA}$ DB(A)
<b>2-pole, 3000 rpm at 50 Hz, temperature class 155 (F), IP55 degree of protection, specially for operation on SIMOVERT MASTERDRIVES</b>							
1LG6 183-2PM□□	2.5	7.2	3.4	16	0.086	67	80
1LG6 206-2PM□□	2.4	7	3.3	16	0.15	71	84
1LG6 207-2PM□□	2.5	7.2	3.3	16	0.18	71	84
1LG6 223-2PM□□	2.5	7.3	3.2	16	0.27	71	84
1LG6 253-2PM□□	2.4	6.8	3	16	0.47	71	84
1LG6 280-2PM□□	2.5	7	3	13	0.83	73	86
1LG6 283-2PM□□	2.6	7.6	3.1	13	1	73	86
1LG6 310-2PM□□	2.4	6.9	2.8	13	1.4	76	89
1LG6 313-2PM□□	2.6	7.1	2.9	13	1.6	76	89
1LG6 316-2PM□□	2.5	7.1	2.9	13	2.1	76	89
1LG6 317-2PM□□	2.5	6.9	2.8	13	2.5	76	89
<b>4-pole, 1500 rpm at 50 Hz, temperature class 155 (F), IP55 degree of protection, specially for operation on SIMOVERT MASTERDRIVES</b>							
1LG6 183-4PM□□	2.5	6.4	3	16	0.12	60	73
1LG6 186-4PM□□	2.5	6.7	3.1	16	0.14	60	73
1LG6 207-4PM□□	2.6	6.7	3.3	16	0.23	62	75
1LG6 220-4PM□□	2.7	6.8	3	16	0.4	60	73
1LG6 223-4PM□□	2.8	6.9	3	16	0.49	60	73
1LG6 253-4PM□□	2.6	7.5	3	16	0.86	65	78
1LG6 280-4PM□□	2.5	6.8	2.9	16	1.4	67	80
1LG6 283-4PM□□	2.7	7.5	3.1	16	1.7	68	82
1LG6 310-4PM□□	2.7	7.1	2.9	16	2.3	68	82
1LG6 313-4PM□□	2.7	7.3	2.9	16	2.9	69	83
1LG6 316-4PM□□	3	7.4	3	16	3.5	69	83
1LG6 317-4PM□□	3.2	7.6	3	16	4.2	69	83
<b>6-pole, 1000 rpm at 50 Hz, temperature class 155 (F), IP55 degree of protection, specially for operation on SIMOVERT MASTERDRIVES</b>							
1LG6 186-6PM□□	2.4	5.5	2.5	16	0.2	56	69
1LG6 206-6PM□□	2.4	5.6	2.4	16	0.29	59	72
1LG6 207-6PM□□	2.4	5.6	2.4	16	0.36	59	72
1LG6 223-6PM□□	2.8	6.5	2.9	16	0.63	59	72
1LG6 253-6PM□□	2.9	6.8	2.5	16	0.93	59	72
1LG6 280-6PM□□	3	6.8	2.7	16	1.4	58	71
1LG6 283-6PM□□	3.3	7.3	2.9	16	1.6	58	71
1LG6 310-6PM□□	2.8	7.3	3	16	2.5	61	74
1LG6 313-6PM□□	2.7	7.3	2.9	16	3.2	61	74
1LG6 316-6PM□□	2.9	7.4	2.9	16	4	61	74
1LG6 317-6PM□□	3.1	7.8	3.1	16	4.7	61	74
1LG6 318-6PM□□	3.2	7.8	3.1	16	5.4	64	77
<b>8-pole, 750 rpm at 50 Hz, temperature class 155 (F), IP55 degree of protection, specially for operation on SIMOVERT MASTERDRIVES</b>							
1LG6 186-8PM□□	1.7	4.6	2.2	13	0.21	62	75
1LG6 207-8PM□□	2.3	5.3	2.6	13	0.37	62	75
1LG6 220-8PM□□	2.3	5.6	2.6	13	0.55	54	67
1LG6 223-8PM□□	2.4	5.8	2.8	13	0.66	58	71
1LG6 253-8PM□□	2.5	6	2.8	13	1.1	57	70
1LG6 280-8PM□□	2.3	5.7	2.3	13	1.4	58	71
1LG6 283-8PM□□	2.6	6.1	2.4	13	1.6	58	71
1LG6 310-8PM□□	2.5	6.3	2.9	13	2.5	61	75
1LG6 313-8PM□□	2.5	6.7	2.9	13	3.1	60	74
1LG6 316-8PM□□	2.4	6.3	2.8	13	3.9	64	77
1LG6 317-8PM□□	2.4	6.4	2.6	13	4.5	64	77
1LG6 318-8PM□□	2.5	6.7	2.9	13	5.3	64	77

For Order No. supplement, see Page 5/16.

# IEC Squirrel-Cage Motors

## Motors operating with frequency converters

Self-ventilated motors with special insulation  
up to 690 V – Cast-iron series 1LG6

### Selection and ordering data (continued)

#### Order No. supplements

Motor type	Penultimate position: Voltage code			Final position: Type of construction code								
	50 Hz	500 VY	500 VΔ	690 VY	Without flange	With flange						
	500 VY	500 VΔ	690 VY		IM B3/6/7/8, IM V6, IM V5 without protective cover <sup>1)</sup>	IM B5, IM V1 without protective cover <sup>2)</sup>	IM V1 without protective cover <sup>2)</sup>	IM V1 with protective cover <sup>2) 3)</sup>	IM B35	With standard flange IM B14, IM V18 with- out protec- tive cover, IM V19	IM B34	With special flange IM B14, IM V18 without protective cover, IM V19
	No rated voltage range											
	<b>3</b>	<b>5</b>	<b>8</b>	<b>0</b>	<b>1</b>	<b>8</b>	<b>4</b>	<b>6</b>	<b>2</b>	<b>7</b>	<b>3</b>	
1LG6 18 . . . PM□□	○	○	○	□	✓	–	✓	✓	–	–	–	
1LG6 20 . . . PM□□	○	○	○	□	✓	–	✓	✓	–	–	–	
1LG6 22 . . . PM□□	○	○	○	□	✓	–	✓	✓	–	–	–	
1LG6 25 . . . PM□□	○	○	○	□	✓	–	✓	✓	–	–	–	
1LG6 28 . . . PM□□	○	○	○	□	✓	–	✓	✓	–	–	–	
1LG6 310 . . . PM□□	○	○	○	□	✓	–	✓	✓	–	–	–	
1LG6 313 . . . PM□□	○	○	○	□	✓	–	✓	✓	–	–	–	
1LG6 316 . . . PM□□	○	○	○	□ <sup>4)</sup>	–	✓ <sup>5)</sup>	✓ <sup>5)</sup>	✓	–	–	–	
1LG6 317 . . . PM□□												
1LG6 318 . . . PM□□												

- Standard version
- Without additional charge
- ✓ With additional charge
- Not possible

Order other voltages with voltage code **9** in the penultimate position and the corresponding order code (see “Special versions” in the “Selection and ordering data” under “Voltages”).

Order other types of construction with type of construction code **9** in the final position and the corresponding order code (see “Special versions” in the “Selection and ordering data” under “Types of construction”).

5

<sup>1)</sup> If motors 1LG6 183-... to 1LG6 318-... (motor series 1LG6 frame sizes 180 M to 315 L) in types of construction with feet IM B6, IM B7, IM V6 or IM V5 without protective cover are fixed to the wall, it is recommended that the motor feet are supported.

<sup>2)</sup> 1LG6 220-... to 1LG6 318-... motors (motor series 1LG6 frame sizes 225 S to 315 L) are supplied with two screw-in eyebolts in accordance with IM B5, whereby one can be relocated in accordance with IM V1 or IM V3. It is important to note that stress must not be applied perpendicular to the ring plane.

<sup>3)</sup> The “Second shaft extension” option, order code **K16** is not possible.

<sup>4)</sup> Type of construction IM V6/IM V5 without protective cover is only possible using type of construction code **9** and order code **M1E** and **M1D**.

<sup>5)</sup> 2-pole motors in 60 Hz version available on request.

# IEC Squirrel-Cage Motors

## Motors operating with frequency converters

Self-ventilated motors FS 315 a. above, w. special insulation up to 690 V – Cast-iron series 1LA8

### Overview

#### Recommended types:

- 1LA8 in output range from 145 to 980 kW (at 50 Hz).

### Selection and ordering data

The data for motor series 1LA8 with special insulation for voltages up to 690 V for converter-fed operation can be found in the "Technical specifications" and "Selection and ordering data" in catalog part 3 "Non-standard motors frame size 315 and above". They are ordered using additional order options (special versions). These special versions for voltages, construction types or options are listed in catalog part 3 "Non-standard motors frame size 315 and above".

Forced-air cooled motors FS 315 a. above, w. fan, with special insulation up to 690 V – Cast-iron series 1PQ8

### Overview

#### Recommended types:

- 1PQ8 in output range from 145 to 980 kW (at 50 Hz)

### Selection and ordering data

The data for motor series 1PQ8 with special insulation for voltages up to 690 V for converter-fed operation can be found in the "Technical specifications" and "Selection and ordering data" in catalog part 3 "Non-standard motors frame size 315 and above". They are ordered using additional order options (special versions). These special versions for voltages, construction types or options are listed in catalog part 3 "Non-standard motors frame size 315 and above". Please inquire about 1PQ8 motors.

# IEC Squirrel-Cage Motors

## Motors operating with frequency converters

### Special versions

#### Overview

##### Motor protection

KTY 84 temperature sensor

Order code

**A23**: 1 x KTY 84-130

**A25**: 2 x KTY 84-130

This sensor is a semi-conductor that changes its resistance depending on temperature in accordance with a defined curve.

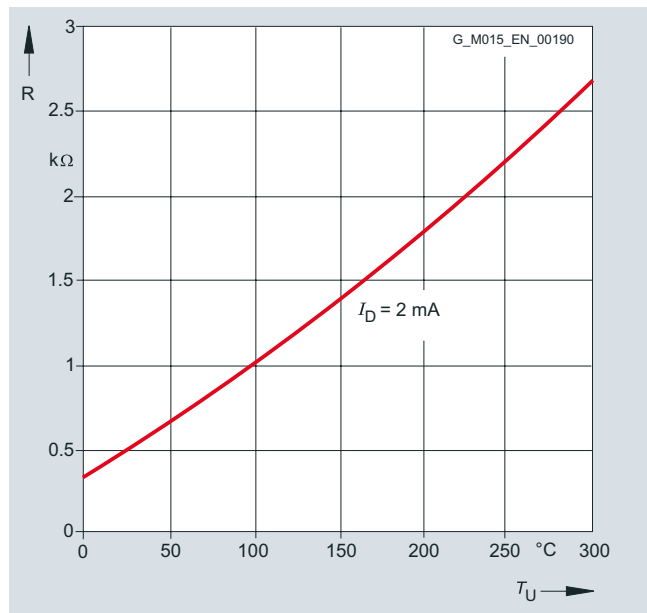

KTY 84 temperature sensor

For 1LA8 motors, the PTC thermistors supplied as standard are omitted when ordering with order code **A23**.

For mains-fed operation, the temperature monitoring device 3RS10 that is part of the protection equipment can be ordered separately. For further details, see Catalog LV1.

##### Motor protection for explosion-proof motors

The explosion-proof motors for Zones 2, 21 and 22 for converter-fed operation (ordered with order codes **M73**, **M38**, **M39**, **M75** or **M77**) already have PTC thermistors for tripping as standard. For converter-fed operation, thermistors can be additionally ordered for alarm (order code **A10**).

For the explosion-proof motor series of Zone 1 with type of protection "d", order codes **A15** and **A16** are available specially for converter-fed operation:

Order code **A15**: Motor protection with PTC thermistors for converter-fed operation with 3 or 4 embedded temperature sensors for tripping.

Order code **A16**: Motor protection with PTC thermistors for converter-fed operation with 6 or 8 embedded temperature sensors for alarm and tripping.

Order code **M77** (incl. order code **A15**): Design for Zones 1 and 21, as well as Zone 22 for conducting dust (IP65) for converter-fed operation, derating.

##### Rating plate data for motors operating with frequency converters for Zones 2, 21 and 22

"MICROMASTER DUTY S9" is stamped on the rating plate as standard, i.e. the rating data for the MICROMASTER converter series from Siemens are indicated. For other converter types (SIMOVERT MASTERDRIVES, SINAMICS G110, SINAMICS S120 or SIMATIC ET 200S FC), the converter type required must be specified in the order in plain text following the order code **Y68**. This is due to the different degree of utilization of the converter and the resulting derating of the motor.

##### Bearing

For converter-fed operation with frame size 225 and above, it is recommended that an "Insulated bearing cartridge" – Order code **L27** is used.

##### Ventilation/noise generation

The fan noise can increase at speeds that are higher than the rated speed of self-ventilated motors.

To increase motor utilization at low speeds, it is recommended that forced ventilated motors are used, in particular motor series 1LA5, 1LA7, 1LG4 and 1LG6 with order code **G17** or motor series 1PQ8.

##### Insulation

For converter-fed operation with the outputs specified in the catalog, the motors are used according to temperature class 155 (F), i.e. in this case neither a service factor >1 nor an increased coolant temperature is possible, that is order codes **C11**, **C12** and **C13** cannot be ordered. Explosion-proof motors for Zones 2, 21 and 22 are utilised in accordance with temperature class 130 (B).

##### Supply frequencies larger than 60 Hz

For converter-fed operation with frequencies greater than 60 Hz, special balancing is required for compliance with the specified limit values (plain text: Max. speed).

# IEC Squirrel-Cage Motors

## Motors operating with frequency converters

Special versions

**Overview** (continued)**ECOFAST motor connectors**

In combination with the ECOFAST versions of the MICROMASTER 411 distributed drive solutions, the following motor connectors can be ordered separately:

- ECOFAST motor connector, standard (unshielded connection): Order code **G55**.
- ECOFAST motor connector, EMC (shielded connection): Order code **G56**.  
Shielded motor connection cables must be used for frequency converters and soft starters.

Maximum admissible mains voltage on motor connector: ≤500 V

**Ordering example:**

Selection criteria	Requirement	Structure of the Order No.
Motor type	Standard motor with high efficiency (EFF1), IP55 degree of protection, aluminum housing	<b>1LA9 000-00000</b>
No. of poles/speed	4-pole/1500 rpm	<b>1LA9 090-4KA90 L1U</b>
Rated output	1.1 kW	
Special voltage and frequency	Star/delta starting for a mains voltage 400 VΔ, 50 Hz <sup>1)</sup>	
Type of construction	IM B3	
ECOFAST connector	Shielded connection	<b>1LA9 090-4KA90 – Z L1U + G56</b>

**Converter mounting**

Motor series 1LA7 with standard insulation up to 500 V in catalog parts 2 “Standard motors up to frame size 315 L” and 7 “Fan motors” can be prepared for mounting an MMI (MICROMASTER Integrated). Order code **H15** is required for this purpose.

**Earth brushes for converter-fed operation**

Earth brushes are available for converter-fed operation for 1LG4 and 1LG6 motors with order code **M44**. Please contact your local Siemens office for advice.

**Motor series with special insulation up to 690 V**

**For motor series 1LA7/5 and 1LG6 with special insulation up to 690 V, the following special versions are generally not possible:**

Description	Order code
With PTC thermistors for alarm for converter-fed operation in Zones 2, 21 and 22	<b>A10</b>
Temperature detectors for tripping	<b>A31</b>
Installation of 3PT100 resistance thermometers	<b>A60</b>
Installation of 6PT100 resistance thermometers in stator winding	<b>A61</b>
Temperature class 155 (F), used acc. to 155 (F), with service factor (SF)	<b>C11</b>
Temperature class 155 (F), used acc. to 155 (F), with increased output	<b>C12</b>
Temperature class 155 (F), used acc. to 155 (F), with increased coolant temperature	<b>C13</b>
Temperature class 180 (H) at rated output and max. CT 60 °C	<b>C18</b>
Increased air humidity/temperature with 30 to 60 g water per m <sup>3</sup> of air	<b>C19</b>
Increased air humidity/temperature with 60 to 100 g water per m <sup>3</sup> of air	<b>C26</b>
Stamping of Ex nA II on VIK rating plate	<b>C27</b>
Coolant temperature –40 °C to +40 °C for EX motor	<b>D19</b>
Design according to UL with “Recognition Mark”	<b>D31</b>
Canadian regulations (CSA)	<b>D40</b>
ECOFAST motor connector Han-Drive 10e for 230 VΔ/400 VY	<b>G55</b>
ECOFAST motor connector EMC Han-Drive 10e for 230 VΔ/400 VY	<b>G56</b>
Prepared for mounting the MICROMASTER Integrated frequency converter	<b>H15</b>
Mounting of explosion-proof rotary pulse encoder for use in Zones 2, 21, 22	<b>H86</b>
VIK design (comprises Zone 2 for mains-fed operation, without Ex nA II marking on rating plate)	<b>K30</b>
Anti-condensation heater, Ex. 115 V	<b>M14</b>
Anti-condensation heater, Ex. 230 V	<b>M15</b>
Design for Zone 21, as well as Zone 22 for conducting dust (IP65) for mains-fed operation	<b>M34</b>
Design for Zone 22 for non-conducting dust (IP55) for mains-fed operation	<b>M35</b>
Design for Zone 21, as well as Zone 22 for conducting dust (IP65) for converter-fed operation, derating	<b>M38</b>
Design for Zone 22 for non-conducting dust (IP55) for converter-fed operation, derating	<b>M39</b>
Design for Zone 2 for mains-fed operation Ex nA II T3 acc. to IEC/EN 60079-15	<b>M72</b>
Design for Zone 2 for converter-fed operation, derating acc. to IEC/EN 60079-15	<b>M73</b>
Design for Zones 2 and 22, for non-conducting dust (IP55), for mains-fed operation	<b>M74</b>
Design for Zones 2 and 22, for non-conducting dust (IP55), for converter-fed operation, derating	<b>M75</b>
Mounting of explosion-proof separately driven fan Ex nA for use in Zone 2	<b>M95</b>
Mounting of explosion-proof separately driven fan II 2D for use in Zone 21	<b>M96</b>
Mounting of explosion-proof separately driven fan II 3D for use in Zone 22	<b>M97</b>
Temperature class 155 (F), used acc. to 155 (F), other requirements	<b>Y52</b>
Alternative converter (SIMOVERT MASTERDRIVES, SINAMICS G110, SINAMICS S120 or ET 200S FC)	<b>Y68</b>

<sup>1)</sup> Note: Voltage code **9** with order code **L1U** must be selected due to the 400 V voltage. With voltage code 6 (= 400 VΔ/690 VY, 50 Hz), temporary voltage peaks of 690 V can arise which can cause faults on the ECOFAST connectors.

# IEC Squirrel-Cage Motors

## Motors operating with frequency converters

### Special versions

#### Selection and ordering data

##### Voltages

Additional order codes for other voltages or voltage codes  
(without **-Z** supplement)

For some non-standard voltages at 50 or 60 Hz, order codes are specified. They are ordered by specifying the code **9** for voltage in the 11th position of the Order No. and the appropriate order code.

Special versions	Voltage code 11th position of the Order No.	Additional identification code with order code and, if required, with plain text	Motor type frame size													
			56	63	71	80	90	100	112	132	160	180	200	225	250	280
<b>Self-ventilated motors with special insulation for voltages up to 690 V – Aluminum series 1LA7 and 1LA5</b>																
										<b>1LA7 (aluminum)</b>		<b>1LA5 (aluminum)</b>				
<b>Non-standard voltage and/or frequencies</b>																
Non-standard winding for voltages between 200 and 690 V (voltages outside this range are available on request) <sup>1)</sup>	<b>9</b>	<b>L1Y •</b>								✓	✓	✓	✓	✓	✓	✓
<b>Self-ventilated motors with special insulation for voltages up to 690 V – Cast-iron series 1LG6</b>																
																<b>1LG6 (cast-iron)</b>
<b>Non-standard voltage and/or frequencies</b>																
Non-standard winding for voltages between 200 and 690 V (voltages outside this range are available on request) <sup>1)</sup>	<b>9</b>	<b>L1Y •</b>														✓ ✓ ✓ ✓ ✓ ✓ <sup>2)</sup>

- ✓ With additional charge
- This order code only determines the price of the version – Additional plain text is required.

<sup>1)</sup> Plain text must be specified in the order: Voltage, frequency, circuit, required rated output in kW.

<sup>2)</sup> For voltages in the 200 V range, please contact your local Siemens representative.



# IEC Squirrel-Cage Motors

## Motors operating with frequency converters

### Special versions

#### Types of construction

Additional order codes for other types of construction or type of construction codes (without **-Z** supplement)

Order codes have been defined for some special types of construction. They are ordered by specifying the code **9** for the type of construction in the 12th position of the Order No. and the appropriate order code.

Special versions	Type of construction code 12th position of the Order No.	Additional identification code with order code and, if required, with plain text	Motor type frame size													2-pole	4-, 6-, 8-pole	
			56	63	71	80	90	100	112	132	160	180	200	225	250			280
<b>Self-ventilated motors with special insulation for voltages up to 690 V – Aluminum series 1LA7 and 1LA5</b>																		
			<b>1LA7 (aluminum)</b>						<b>1LA5 (aluminum)</b>									
<b>Without flange</b>																		
IM V5 with protective cover <sup>1)</sup>	<b>9</b>	<b>M1F</b>	✓	✓	✓	✓	✓	✓	✓	✓								
<b>With flange</b>																		
IM V3 <sup>2)</sup>	<b>9</b>	<b>M1G</b>	–	–	–	–	–	✓	✓	✓								
<b>With standard flange</b>																		
IM V18 with protective cover <sup>1)</sup>	<b>9</b>	<b>M2A</b>	✓	✓	✓	✓	✓	–	–	–								
<b>With special flange</b>																		
IM V18 with protective cover <sup>1)</sup>	<b>9</b>	<b>M2B</b>	✓	✓	✓	✓	✓	–	–	–								
IM B34	<b>9</b>	<b>M2C</b>	✓	✓	✓	✓	✓	–	–	–								
<b>Self-ventilated motors with special insulation for voltages up to 690 V – Cast-iron series 1LG6</b>																		
			<b>1LG6 (cast-iron)</b>															
<b>Without flange</b>																		
IM V5 without protective cover <sup>4)</sup>	<b>9</b>	<b>M1D</b>	–	–	–	–	–	–	–	–	–	–	–	–	–	–	✓ <sup>3)</sup>	○
IM V6 <sup>4)</sup>	<b>9</b>	<b>M1E</b>	–	–	–	–	–	–	–	–	–	–	–	–	–	–	✓ <sup>3)</sup>	○
IM V5 with protective cover <sup>1) 4)</sup>	<b>9</b>	<b>M1F</b>	✓	✓	✓	✓	✓	✓	✓	✓	✓	✓	✓	✓	✓	✓	✓ <sup>3)</sup>	✓
<b>With flange</b>																		
IM V3 <sup>5)</sup>	<b>9</b>	<b>M1G</b>	✓	✓	✓	✓	✓	✓	✓	✓	✓	✓	✓	✓	✓	–	–	–

- Without additional charge
- ✓ With additional charge
- Not possible

<sup>1)</sup> The "Second shaft extension" option, order code **K16** is not possible.  
<sup>2)</sup> For frame sizes 180 M to 225 M, the 1LA5 motors can be supplied with two additional eyebolts; state Order No. suffix **"Z"** and order code **K32**.  
<sup>3)</sup> 60 Hz version is possible on request

<sup>4)</sup> If motors of frame sizes 180 M to 315 L are mounted on the wall, it is recommended that the motor feet are supported.  
<sup>5)</sup> 1LG6 motors of frame sizes 225 S to 315 M are supplied with two screw-in eyebolts in accordance with IM B5, whereby one can be relocated in accordance with IM V1 or IM V3. It is important to note that stress must not be applied perpendicular to the ring plane.

# IEC Squirrel-Cage Motors

## Motors operating with frequency converters

### Special versions

#### Options

Options or order codes (supplement **-Z** is required)

Special versions	Additional identification code <b>-Z</b> with order code and plain text if required	Motor type frame size														
		56	63	71	80	90	100	112	132	160	180	200	225	250	280	315
<b>Self-ventilated motors with special insulation for voltages up to 690 V – Aluminum series 1LA7 and 1LA5</b>																
											<b>1LA7 (aluminum)</b>		<b>1LA5 (aluminum)</b>			
<b>Motor protection</b>																
Motor protection with PTC thermistors with 3 embedded temperature sensors for tripping <sup>1)</sup>	<b>A11</b>										✓	✓	✓	✓	✓	✓
Motor protection with PTC thermistors with 6 embedded temperature sensors for tripping and alarm <sup>1)</sup>	<b>A12</b>										✓	✓	✓	✓	✓	✓
Motor temperature detection with embedded temperature sensor KTY 84-130 <sup>1)</sup>	<b>A23</b>										✓	✓	✓	✓	✓	✓
Motor temperature detection with embedded temperature sensors 2 x KTY 84-130 <sup>1)</sup>	<b>A25</b>										✓	✓	✓	✓	✓	✓
<b>Motor connection and connection box</b>																
Connection box on RHS	<b>K09</b>										✓	✓	✓	✓	✓	✓
Connection box on LHS	<b>K10</b>										✓	✓	✓	✓	✓	✓
One cable gland, metal	<b>K54</b>										✓	✓	✓	✓	✓	✓
Cable gland, maximum configuration	<b>K55</b>										✓	✓	✓	✓	✓	✓
Rotation of the connection box through 90°, entry from DE (AS)	<b>K83</b>										✓	✓	✓	✓	✓	✓
Rotation of the connection box through 90°, entry from NDE (BS)	<b>K84</b>										✓	✓	✓	✓	✓	✓
Rotation of connection box through 180°	<b>K85</b>										○	○	○	○	✓	✓
Next larger connection box	<b>L00</b>										–	–	–	–	✓	✓
External earthing	<b>L13</b>										✓	✓	✓	✓	✓	✓
3 cables protruding, 0.5 m long <sup>2)</sup>	<b>L44</b>										O. R.	O. R.	O. R.	O. R.	O. R.	O. R.
3 cables protruding, 1.5 m long <sup>2)</sup>	<b>L45</b>										O. R.	O. R.	O. R.	O. R.	O. R.	O. R.
6 cables protruding, 0.5 m long <sup>2)</sup>	<b>L47</b>										O. R.	O. R.	O. R.	O. R.	O. R.	O. R.
6 cables protruding, 1.5 m long <sup>2)</sup>	<b>L48</b>										O. R.	O. R.	O. R.	O. R.	O. R.	O. R.
6 cables protruding, 3 m long <sup>2)</sup>	<b>L49</b>										–	–	–	–	O. R.	O. R.
Connection box on NDE (BS)	<b>M64</b>										✓	✓	✓	✓	✓	✓
<b>Windings and insulation</b>																
Temperature class 155 (F), used acc. to 130 (B), coolant temperature 45 °C, derating approx. 4 %	<b>C22</b>										✓	✓	✓	✓	✓	✓
Temperature class 155 (F), used acc. to 130 (B), coolant temperature 50 °C, derating approx. 8 %	<b>C23</b>										✓	✓	✓	✓	✓	✓
Temperature class 155 (F), used acc. to 130 (B), coolant temperature 55 °C, derating approx. 13 %	<b>C24</b>										✓	✓	✓	✓	✓	✓
Temperature class 155 (F), used acc. to 130 (B), coolant temperature 60 °C, derating approx. 18 %	<b>C25</b>										✓	✓	✓	✓	✓	✓

For legend and footnotes, see Page 5/26.

# IEC Squirrel-Cage Motors

## Motors operating with frequency converters

### Special versions

Special versions	Additional identification code <b>-Z</b> with order code and plain text if required	Motor type frame size														
		56	63	71	80	90	100	112	132	160	180	200	225	250	280	315
<b>Self-ventilated motors with special insulation for voltages up to 690 V – Aluminum series 1LA7 and 1LA5</b>																
							<b>1LA7 (aluminum)</b>				<b>1LA5 (aluminum)</b>					
<b>Colors and paint finish</b>																
Special finish in RAL 7030 stone gray							☐	☐	☐	☐	☐	☐	☐	☐	☐	☐
Special finish in other standard RAL colors: RAL 1002, 1013, 1015, 1019, 2003, 2004, 3000, 3007, 5007, 5009, 5010, 5012, 5015, 5017, 5018, 5019, 6011, 6019, 6021, 7000, 7001, 7004, 7011, 7016, 7022, 7031, 7032, 7033, 7035, 9001, 9002, 9005 Page 0/18	<b>Y54•</b> and special finish RAL ....						✓	✓	✓	✓	✓	✓	✓	✓	✓	✓
Special finish in special RAL colors: For RAL colors, see "Special finish in special RAL colors" on Page 0/19	<b>Y51•</b> and special finish RAL ....						✓	✓	✓	✓	✓	✓	✓	✓	✓	✓
Sea air resistant special finish	<b>M94</b>						O. R.	O. R.	O. R.	O. R.	O. R.	O. R.	O. R.	O. R.	O. R.	O. R.
Unpainted (only cast iron parts primed)	<b>K23</b>						○	○	○	○	○	○	○	○	○	○
Unpainted, only primed	<b>K24</b>						✓	✓	✓	✓	✓	✓	✓	✓	✓	✓
<b>Modular technology – Basic versions <sup>3)</sup></b>																
Mounting of separately driven fan	<b>G17</b>						✓	✓	✓	✓	✓	✓	✓	✓	✓	✓
Mounting of brake <sup>4)</sup>	<b>G26</b>						✓	✓	✓	✓	✓	✓	✓	✓	✓	✓
Mounting of 1XP8 001-1 (HTL) rotary pulse encoder	<b>H57</b>						✓	✓	✓	✓	✓	✓	✓	✓	✓	✓
Mounting of 1XP8 001-2 (TTL) rotary pulse encoder	<b>H58</b>						✓	✓	✓	✓	✓	✓	✓	✓	✓	✓
<b>Modular technology – Combinations of basic versions <sup>3)</sup></b>																
Mounting of separately driven fan and 1XP8 001-1 rotary pulse encoder	<b>H61</b>						✓	✓	✓	✓	✓	✓	✓	✓	✓	✓
Mounting of brake and 1XP8 001-1 rotary pulse encoder <sup>4)</sup>	<b>H62</b>						✓	✓	✓	✓	✓	✓	✓	✓	✓	✓
Mounting of brake and separately driven fan <sup>4)</sup>	<b>H63</b>						✓	✓	✓	✓	✓	✓	✓	✓	✓	✓
Mounting of brake, separately driven fan and 1XP8 001-1 rotary pulse encoder <sup>4)</sup>	<b>H64</b>						✓	✓	✓	✓	✓	✓	✓	✓	✓	✓
Mounting of separately driven fan and 1XP8 001-2 rotary pulse encoder	<b>H97</b>						✓	✓	✓	✓	✓	✓	✓	✓	✓	✓
Mounting of brake and 1XP8 001-2 rotary pulse encoder <sup>4)</sup>	<b>H98</b>						✓	✓	✓	✓	✓	✓	✓	✓	✓	✓
Mounting of brake, separately driven fan and 1XP8 001-2 rotary pulse encoder <sup>4)</sup>	<b>H99</b>						✓	✓	✓	✓	✓	✓	✓	✓	✓	✓

# IEC Squirrel-Cage Motors

## Motors operating with frequency converters

### Special versions

Special versions	Additional identification code <b>-Z</b> with order code and plain text if required	Motor type frame size														
		56	63	71	80	90	100	112	132	160	180	200	225	250	280	315
<b>Self-ventilated motors with special insulation for voltages up to 690 V – Aluminum series 1LA7 and 1LA5</b>																
											<b>1LA7 (aluminum)</b>		<b>1LA5 (aluminum)</b>			
<b>Modular technology – Additional versions</b>																
Brake supply voltage 24 V DC	<b>C00</b>										✓	✓	✓	✓	✓	✓
Brake supply voltage 400 V AC	<b>C01</b>										✓	✓	✓	✓	✓	✓
Brake supply voltage 180 V DC, for operation on MM411-ECOFAST	<b>C02</b>										✓	✓	✓	–	–	–
Mechanical manual brake release with lever (no locking)	<b>K82</b>										✓	✓	✓	✓	✓	✓
<b>Special technology <sup>3)</sup></b>																
Mounting of LL 861 900 220 rotary pulse encoder	<b>H70</b>										✓	✓	✓	✓	✓	✓
Mounting of HOG 9 D 1024 I rotary pulse encoder	<b>H72</b>										✓	✓	✓	✓	✓	✓
Mounting of HOG 10 D 1024 I rotary pulse encoder	<b>H73</b>										✓	✓	✓	✓	✓	✓
Prepared for mounting LL 861 900 220	<b>H78</b>										✓	✓	✓	✓	✓	✓
Prepared for mounting HOG 9 D 1024 I	<b>H79</b>										✓	✓	✓	✓	✓	✓
Prepared for mounting HOG 10 D 1024 I	<b>H80</b>										✓	✓	✓	✓	✓	✓
<b>Mechanical design and degrees of protection</b>																
Drive-end seal for flange-mounting motors with oil resistance up to 0.1 bar Not possible for IM V3 type of construction.	<b>K17</b>										✓	✓	✓	✓	✓	✓
With two additional eyebolts for IM V1/IM V3	<b>K32</b>										–	–	–	–	✓	✓
Low-noise version for 2-pole motors with clockwise direction of rotation	<b>K37</b>										–	–	✓	✓	✓	✓
Low-noise version for 2-pole motors with counter-clockwise direction of rotation	<b>K38</b>										–	–	✓	✓	✓	✓
IP65 degree of protection <sup>5)</sup>	<b>K50</b>										✓	✓	✓	✓	✓	✓
IP56 degree of protection (non-heavy-sea) <sup>6)</sup>	<b>K52</b>										✓	✓	✓	✓	✓	✓
Vibration-proof version	<b>L03</b>										✓	✓	✓	✓	✓	✓
Condensation drainage holes <sup>7)</sup>	<b>L12</b>										✓	✓	✓	✓	✓	✓
Non-rusting screws (externally)	<b>M27</b>										✓	✓	✓	✓	✓	✓
Mechanical protection for encoder <sup>8)</sup>	<b>M68</b>										✓	✓	✓	✓	✓	✓
<b>Coolant temperature and site altitude</b>																
Coolant temperature –40 to +40 °C <sup>9)</sup>	<b>D03</b>										✓	✓	✓	✓	✓	✓
Coolant temperature –30 to +40 °C <sup>9)</sup>	<b>D04</b>										✓	✓	✓	✓	✓	✓

5

For legend and footnotes, see Page 5/26.

# IEC Squirrel-Cage Motors

## Motors operating with frequency converters

### Special versions

Special versions	Additional identification code <b>-Z</b> with order code and plain text if required	Motor type frame size														
		56	63	71	80	90	100	112	132	160	180	200	225	250	280	315
<b>Self-ventilated motors with special insulation for voltages up to 690 V – Aluminum series 1LA7 and 1LA5</b>																
<b>Designs in accordance with standards and specifications</b>																
CCC China Compulsory Certification <sup>10)</sup>	<b>D01</b>						✓	✓	–	–	–	–	–	–	–	–
Electrical according to NEMA MG1-12	<b>D30</b>						✓	✓	✓	✓	✓	✓	✓	✓	✓	✓
<b>Bearings and lubrication</b>																
Measuring nipple for SPM shock pulse measurement for bearing inspection <sup>11)</sup>	<b>G50</b>						✓	✓	✓	✓	✓	✓	✓	✓	✓	✓
Bearing design for increased cantilever forces	<b>K20</b>						✓	✓	✓	✓	✓	✓	✓	✓	✓	✓
Regreasing device <sup>11)</sup>	<b>K40</b>						✓	✓	✓	✓	✓	✓	✓	✓	✓	✓
Located bearing DE (AS)	<b>K94</b>						✓	✓	✓	✓	✓	✓	✓	✓	✓	✓
Located bearing NDE (BS)	<b>L04</b>						✓	✓	✓	✓	□	□	□	□	□	□
<b>Balance and vibration quantity</b>																
Vibration quantity level A							□	□	□	□	□	□	□	□	□	□
Vibration quantity level B	<b>K02</b>						✓	✓	✓	✓	✓	✓	✓	✓	✓	✓
Full key balancing	<b>L68</b>						✓	✓	✓	✓	✓	✓	✓	✓	✓	✓
Balancing without key	<b>M37</b>						✓	✓	✓	✓	✓	✓	✓	✓	✓	✓
<b>Shaft and rotor</b>																
Concentricity of shaft extension, coaxiality and linear movement in accordance with DIN 42955 Tolerance R for flange-mounting motors <sup>12)</sup>	<b>K04</b>						✓	✓	✓	✓	✓	✓	✓	✓	✓	✓
Second standard shaft extension	<b>K16</b>						✓	✓	✓	✓	✓	✓	✓	✓	✓	✓
Shaft extension with normal dimensions without feather key	<b>K42</b>						✓	✓	✓	✓	✓	✓	✓	✓	✓	✓
Concentricity of shaft extension in accordance with DIN 42955 Tolerance R	<b>L39</b>						✓	✓	✓	✓	✓	✓	✓	✓	✓	✓
Standard shaft made of non-rusting steel	<b>M65</b>						✓	✓	✓	✓	✓	✓	✓	✓	✓	✓
Non-standard cylindrical shaft extension <sup>13)</sup>	<b>Y55 •</b> and identification code						✓	✓	✓	✓	✓	✓	✓	✓	✓	✓
<b>Heating and ventilation</b>																
Fan cover for textile industry	<b>H17</b>						✓	✓	✓	✓	✓	✓	✓	✓	✓	✓
Metal external fan <sup>14)</sup>	<b>K35</b>						✓	✓	✓	✓	✓	✓	✓	✓	✓	✓
Anti-condensation heaters for 230 V	<b>K45</b>						O. R.	O. R.	O. R.	O. R.	O. R.	O. R.	O. R.	O. R.	O. R.	O. R.
Anti-condensation heaters for 115 V	<b>K46</b>						O. R.	O. R.	O. R.	O. R.	O. R.	O. R.	O. R.	O. R.	O. R.	O. R.
<b>Rating plate and extra rating plates</b>																
Second lubricating plate, supplied loose	<b>B06</b>						✓	✓	✓	✓	✓	✓	✓	✓	✓	✓
Second rating plate, loose	<b>K31</b>						✓	✓	✓	✓	✓	✓	✓	✓	✓	✓
Extra rating plate or rating plate with deviating rating plate data	<b>Y80 •</b> and identification code						✓	✓	✓	✓	✓	✓	✓	✓	✓	✓
Extra rating plate with identification code	<b>Y82 •</b> and identification code						✓	✓	✓	✓	✓	✓	✓	✓	✓	✓
Additional information on rating plate and on package label (maximum of 20 characters)	<b>Y84 •</b> and identification code						✓	✓	✓	✓	✓	✓	✓	✓	✓	✓

# IEC Squirrel-Cage Motors

## Motors operating with frequency converters

### Special versions

Special versions	Additional identification code <b>-Z</b> with order code and plain text if required	Motor type frame size														
		56	63	71	80	90	100	112	132	160	180	200	225	250	280	315
<b>Self-ventilated motors with special insulation for voltages up to 690 V – Aluminum series 1LA7 and 1LA5</b>																
<b>Packaging, safety notes, documentation and test certificates</b>																
Without safety and commissioning note. Customer's declaration of renouncement required.	<b>B00</b>															
With one safety and startup guide per box pallet	<b>B01</b>															
Acceptance test certificate 3.1 according to EN 10204	<b>B02</b>															
Operating instructions German/English enclosed in print	<b>B23</b>															
Wire-lattice pallet	<b>L99</b>															
Connected in star for dispatch	<b>M32</b>															
Connected in delta for dispatch	<b>M33</b>															

- Standard version
- Without additional charge
- This order code only determines the price of the version – Additional plain text is required.
- O.R. Possible on request
- ✓ With additional charge
- Not possible

5

- 1) Evaluation with appropriate tripping unit (see Catalog LV 1) is recommended.
- 2) In combination with the PTC thermistor option or anti-condensation heating option, please inquire before ordering.
- 3) A second shaft extension is not possible. Please inquire for mounted brakes. The order codes listed cannot be combined within the various technologies nor with each other within the same technology system. This applies for:
  - Modular technology – Basic versions
  - Modular technology – Combination of basic versions
  - Special technology
- 4) The standard brake supply voltage is 230 V AC, 50/60 Hz. Other brake supply voltages are possible with order codes **C00**, **C01** and **C02**.
- 5) Not possible in combination with rotary pulse encoder HOG 9 D 1024I (order code **H72**, **H79**) and/or brake 2LM8 (used for motors up to and including frame size 225, order code **G26**).
- 6) Not possible in combination with brake 2LM8 (used for motors up to and including frame size 225, order code **G26**).
- 7) Supplied with the condensation drainage holes sealed at the drive end DE and non-drive end NDE for IP55, IP56 and IP65 degrees of protection. If condensation drainage holes are required in motors of the IM B6, IM B7 or IM B8 type of construction (feet located on side or top), it is necessary to relocate the bearing plates at the drive end (DE) and non-drive end (NDE) so that the condensation drainage holes situated between the feet on delivery are underneath.
- 8) Not necessary when a rotary pulse encoder is combined with a separately driven fan, because in this case the rotary pulse encoder is installed under the fan cover.
- 9) In connection with mountings, the respective technical data must be observed; request required.
- 10) CCC certification is required for
  - 2-pole motors  $\leq 2.2$  kW
  - 4-pole motors  $\leq 1.1$  kW
  - 6-pole motors  $\leq 0.75$  kW
  - 8-pole motors  $\leq 0.55$  kW
- 11) Not possible when brake is mounted.
- 12) Can be combined with deep-groove bearings of series 60.., 62.. and 63.. . Not possible with parallel roller bearings (e.g. bearings for increased cantilever forces, order code **K20**) brake or encoder fitting.
- 13) When motors are ordered that have a longer or shorter shaft extension than normal, the required position and length of the featherkey way must be specified in a sketch. It must be ensured that only featherkeys in accordance with DIN 6885, Form A are permitted to be used. The featherkey way is positioned centrally on the shaft extension. The length is defined by the manufacturer normatively.
 

Not applicable for: Conical shafts, non-standard threaded journals, non-standard shaft tolerances, friction welded journals, extremely "thin" shafts, special geometry dimensions (e.g. square journals), hollow shafts. Valid for non-standard shaft extensions DE or NDE. The featherkeys are supplied in every case.

The add-on prices also apply for "Shaft extension DE without featherkey way".

For order codes **Y55** and **K16**:

  - Dimensions D and DA  $\leq$  Inner diameter of roller bearing (see tables under "Dimensions")
  - Dimensions E and EA  $\leq 2 \times$  Length E (normal) of the shaft extension

For explanation of the order codes, see catalog part 0 "Introduction".
- 14) For 1LA5, 1LA6, 1LA7, 1LA9 motors and 1LG with metal external fan, converter-fed operation is permitted. The metal external fan is not possible in combination with the low-noise version – order code **K37** or **K38**.

# IEC Squirrel-Cage Motors

## Motors operating with frequency converters

### Special versions

Special versions	Additional identification code -Z with order code and plain text if required	Motor type frame size															
		56	63	71	80	90	100	112	132	160	180	200	225	250	280	315	
<b>Self-ventilated motors with special insulation for voltages up to 690 V – Cast-iron series 1LG6</b>																	
<b>1LG6 (cast-iron)</b>																	
<b>Motor protection</b>																	
Motor protection with PTC thermistors with 3 embedded temperature sensors for tripping <sup>1)</sup>	<b>A11</b>											✓	✓	✓	✓	✓	✓
Motor protection with PTC thermistors with 6 embedded temperature sensors for tripping and alarm <sup>1)</sup>	<b>A12</b>											✓	✓	✓	✓	✓	✓
Motor temperature detection with embedded temperature sensor KTY 84-130 <sup>1)</sup>	<b>A23</b>											✓	✓	✓	✓	✓	✓
Motor temperature detection with embedded temperature sensors 2 x KTY 84-130 <sup>1)</sup>	<b>A25</b>											✓	✓	✓	✓	✓	✓
Temperature detectors for tripping <sup>1)</sup>	<b>A31</b>											✓	✓	✓	✓	✓	✓
Installation of 2 PT 100 screw-in resistance thermometers (basic circuit) for rolling-contact bearings <sup>1) 2)</sup>	<b>A72</b>											✓	✓	✓	✓	✓	✓
Installation of 2 PT 100 screw-in resistance thermometers (3-wire circuit) for rolling-contact bearings <sup>1)</sup>	<b>A78</b>											✓	✓	✓	✓	✓	✓
Installation of 2 PT 100 double screw-in resistance thermometers (3-wire circuit) for rolling-contact bearings <sup>1)</sup>	<b>A80</b>											✓	✓	✓	✓	✓	✓
<b>Motor connection and connection box</b>																	
Two-part plate on connection box	<b>K06</b>											–	✓	✓	✓	✓	✓
Connection box on RHS	<b>K09</b>											✓	✓	✓	✓	✓	✓
Connection box on LHS	<b>K10</b>											✓	✓	✓	✓	✓	✓
Connection box on top, feet screwed on	<b>K11</b>											✓	✓	✓	✓	✓	✓
Connection box in cast-iron version	<b>K15</b>											✓	✓	✓	–	–	–
One cable gland, metal	<b>K54</b>											✓	✓	✓	✓	✓	✓
Cable gland, maximum configuration	<b>K55</b>											✓	✓	✓	✓	✓	✓
Rotation of the connection box through 90°, entry from DE	<b>K83</b>											✓	✓	✓	✓	✓	✓
Rotation of the connection box through 90°, entry from NDE	<b>K84</b>											✓	✓	✓	✓	✓	✓
Rotation of connection box through 180°	<b>K85</b>											✓	✓	✓	✓	✓	✓
Next larger connection box	<b>L00</b>											✓	✓	✓	✓	✓	✓
6 cables protruding, 1.5 m long <sup>3)</sup>	<b>L48</b>											O. R.	O. R.	O. R.	O. R.	O. R.	O. R.
6 cables protruding, 3 m long <sup>3)</sup>	<b>L49</b>											O. R.	O. R.	O. R.	O. R.	O. R.	O. R.
Protruding cable ends – right side <sup>3) 4)</sup>	<b>L51</b>											O. R.	O. R.	O. R.	O. R.	O. R.	O. R.
Protruding cable ends – left side <sup>3) 4)</sup>	<b>L52</b>											O. R.	O. R.	O. R.	O. R.	O. R.	O. R.
Auxiliary connection box 1XB3 020	<b>L97</b>											✓	✓	✓	✓	✓	✓
Stud terminal for cable connection, accessories pack (3 items)	<b>M46</b>											–	–	–	✓	✓	✓
Saddle terminal for connection without cable lug, accessories pack (6 items)	<b>M47</b>											–	–	–	✓	✓	✓

# IEC Squirrel-Cage Motors

## Motors operating with frequency converters

### Special versions

Special versions	Additional identification code <b>-Z</b> with order code and plain text if required	Motor type frame size															
		56	63	71	80	90	100	112	132	160	180	200	225	250	280	315	
<b>Self-ventilated motors with special insulation for voltages up to 690 V – Cast-iron series 1LG6</b>																	
<b>1LG6 (cast-iron)</b>																	
<b>Windings and insulation</b>																	
Temperature class 155 (F), used acc. to 130 (B), coolant temperature 45 °C, derating approx. 4 %	<b>C22</b>											✓	✓	✓	✓	✓	✓
Temperature class 155 (F), used acc. to 130 (B), coolant temperature 50 °C, derating approx. 8 %	<b>C23</b>											✓	✓	✓	✓	✓	✓
Temperature class 155 (F), used acc. to 130 (B), coolant temperature 55 °C, derating approx. 13 %	<b>C24</b>											✓	✓	✓	✓	✓	✓
Temperature class 155 (F), used acc. to 130 (B), coolant temperature 60 °C, derating approx. 18 %	<b>C25</b>											✓	✓	✓	✓	✓	✓
<b>Colors and paint finish</b>																	
Standard finish in RAL 7030 stone gray												□	□	□	□	□	□
Standard finish in other standard RAL colors: RAL 1002, 1013, 1015, 1019, 2003, 2004, 3000, 3007, 5007, 5009, 5010, 5012, 5015, 5017, 5018, 5019, 6011, 6019, 6021, 7000, 7001, 7004, 7011, 7016, 7022, 7031, 7032, 7033, 7035, 9001, 9002, 9005 Page 0/18	<b>Y53 •</b> and standard finish RAL ....											✓	✓	✓	✓	✓	✓
Special finish in RAL 7030 stone gray	<b>K26</b>											✓	✓	✓	✓	✓	✓
Special finish in other standard RAL colors: RAL 1002, 1013, 1015, 1019, 2003, 2004, 3000, 3007, 5007, 5009, 5010, 5012, 5015, 5017, 5018, 5019, 6011, 6019, 6021, 7000, 7001, 7004, 7011, 7016, 7022, 7031, 7032, 7033, 7035, 9001, 9002, 9005 Page 0/18	<b>Y54 •</b> and special finish RAL ....											✓	✓	✓	✓	✓	✓
Special finish in special RAL colors: For RAL colors, see "Special finish in special RAL colors" Page 0/19	<b>Y51 •</b> and special finish RAL ....											✓	✓	✓	✓	✓	✓
Offshore special finish	<b>M91</b>											✓	✓	✓	✓	✓	✓
Sea air resistant special finish	<b>M94</b>											O. R.	O. R.	O. R.	O. R.	O. R.	O. R.
Unpainted (only cast iron parts primed)	<b>K23</b>											○	○	○	○	○	○
Unpainted, only primed	<b>K24</b>											✓	✓	✓	✓	✓	✓
<b>Modular technology – Basic versions <sup>5)</sup></b>																	
Mounting of separately driven fan <sup>6)</sup>	<b>G17</b>											✓	✓	✓	✓	✓	✓
Mounting of brake <sup>6) 7)</sup>	<b>G26</b>											✓	✓	✓	✓	✓	✓
Mounting of 1XP8 001-1 (HTL) rotary pulse encoder	<b>H57</b>											✓	✓	✓	✓	✓	✓
Mounting of 1XP8 001-2 (TTL) rotary pulse encoder	<b>H58</b>											✓	✓	✓	✓	✓	✓

For legend and footnotes, see Page 5/31.



# IEC Squirrel-Cage Motors

## Motors operating with frequency converters

### Special versions

Special versions	Additional identification code -Z with order code and plain text if required	Motor type frame size															
		56	63	71	80	90	100	112	132	160	180	200	225	250	280	315	
<b>Self-ventilated motors with special insulation for voltages up to 690 V – Cast-iron series 1LG6</b>																	
<b>1LG6 (cast-iron)</b>																	
<b>Modular technology – Combinations of basic versions <sup>5)</sup></b>																	
Mounting of separately driven fan and 1XP8 001-1 rotary pulse encoder	<b>H61</b>											✓	✓	✓	✓	✓	✓
Mounting of brake and 1XP8 001-1 rotary pulse encoder <sup>7)</sup>	<b>H62</b>											✓	✓	✓	✓	✓	✓
Mounting of brake and separately driven fan <sup>7)</sup>	<b>H63</b>											✓	✓	✓	✓	✓	✓
Mounting of brake, separately driven fan and 1XP8 001-1 rotary pulse encoder <sup>7)</sup>	<b>H64</b>											✓	✓	✓	✓	✓	✓
Mounting of separately driven fan and 1XP8 001-2 rotary pulse encoder	<b>H97</b>											✓	✓	✓	✓	✓	✓
Mounting of brake and 1XP8 001-2 rotary pulse encoder <sup>7)</sup>	<b>H98</b>											✓	✓	✓	✓	✓	✓
Mounting of brake, separately driven fan and 1XP8 001-2 rotary pulse encoder <sup>7)</sup>	<b>H99</b>											✓	✓	✓	✓	✓	✓
<b>Modular technology – Additional versions</b>																	
Brake supply voltage 24 V DC	<b>C00</b>											✓	✓	✓	✓	✓	✓
Brake supply voltage 400 V AC	<b>C01</b>											✓	✓	✓	✓	✓	✓
Mechanical manual brake release with lever (no locking)	<b>K82</b>											✓	✓	✓	✓	✓	✓
<b>Special technology <sup>5)</sup></b>																	
Mounting of LL 861 900 220 rotary pulse encoder	<b>H70</b>											✓	✓	✓	✓	✓	✓
Mounting of HOG 9 D 1024 I rotary pulse encoder	<b>H72</b>											✓	✓	✓	✓	✓	✓
Mounting of HOG 10 D 1024 I rotary pulse encoder	<b>H73</b>											✓	✓	✓	✓	✓	✓
Prepared for mounting LL 861 900 220	<b>H78</b>											✓	✓	✓	✓	✓	✓
Prepared for mounting HOG 9 D 1024 I	<b>H79</b>											✓	✓	✓	✓	✓	✓
Prepared for mounting HOG 10 D 1024 I	<b>H80</b>											✓	✓	✓	✓	✓	✓
<b>Mechanical design and degrees of protection</b>																	
Drive-end seal for flange-mounting motors with oil resistance to 0.1 bar. Not possible for IM V3 type of construction and 2-pole motors.	<b>K17</b>											✓	✓	✓	✓	✓	✓
Low-noise version for 2-pole motors with clockwise direction of rotation <sup>8)</sup>	<b>K37</b>											–	–	–	–	–	–
Low-noise version for 2-pole motors with counter-clockwise direction of rotation <sup>8)</sup>	<b>K38</b>											–	–	–	–	–	–
IP65 degree of protection <sup>9)</sup>	<b>K50</b>											✓	✓	✓	✓	✓	✓
IP56 degree of protection (non-heavy-sea) <sup>10)</sup>	<b>K52</b>											✓	✓	✓	✓	✓	✓
Condensation water holes <sup>11)</sup>	<b>L12</b>											□	□	□	□	□	□
Non-rusting screws (externally)	<b>M27</b>											✓	✓	✓	✓	✓	✓
Earth brushes for converter-fed operation	<b>M44</b>											–	–	–	–	O. R.	O. R.
Mechanical protection for encoder <sup>12)</sup>	<b>M68</b>											✓	✓	✓	✓	✓	✓

# IEC Squirrel-Cage Motors

## Motors operating with frequency converters

### Special versions

Special versions	Additional identification code -Z with order code and plain text if required	Motor type frame size														
		56	63	71	80	90	100	112	132	160	180	200	225	250	280	315
<b>Self-ventilated motors with special insulation for voltages up to 690 V – Cast-iron series 1LG6</b>																
<b>1LG6 (cast-iron)</b>																
<b>Coolant temperature and site altitude</b>																
Coolant temperature –50 to +40 °C <sup>13)</sup>	<b>D02</b>										✓	✓	✓	✓	✓	✓
Coolant temperature –40 to +40 °C <sup>13)</sup>	<b>D03</b>										✓	✓	✓	✓	✓	✓
Coolant temperature –30 to +40 °C <sup>13)</sup>	<b>D04</b>										✓	✓	✓	✓	✓	✓
<b>Bearings and lubrication</b>																
Measuring nipple for SPM shock pulse measurement for bearing inspection	<b>G50</b>										✓	✓	✓	✓	✓	✓
Bearing design for increased cantilever forces <sup>14)</sup>	<b>K20</b>										✓	✓	✓	✓	✓	✓
Special bearing for DE and NDE, bearing size 63	<b>K36</b>										✓	✓	✓	✓	✓ <sup>15)</sup>	✓ <sup>15)</sup>
Regreasing device	<b>K40</b>										✓	✓	✓	✓	□	□
Located bearing DE	<b>K94</b>										✓	✓	✓	✓	✓	✓
Located bearing NDE	<b>L04</b>										□	□	□	□	□	□
Insulated bearing cartridge <sup>16)</sup>	<b>L27</b>										–	–	✓	✓	✓	✓
<b>Balance and vibration quantity</b>																
Vibration quantity level A											□	□	□	□	□	□
Vibration quantity level B	<b>K02</b>										✓	✓	✓	✓	✓	✓
Full key balancing	<b>L68</b>										✓	✓	✓	✓	✓	✓
Balancing without key	<b>M37</b>										✓	✓	✓	✓	✓	✓
<b>Shaft and rotor</b>																
Concentricity of shaft extension, coaxiality and linear movement in accordance with DIN 42955 Tolerance R <sub>1</sub> for flange-mounting motors <sup>17)</sup>	<b>K04</b>										✓	✓	✓	✓	✓	✓
Second standard shaft extension <sup>18)</sup>	<b>K16</b>										✓	✓	✓	✓	✓	✓
Shaft extension with normal dimensions without feather key	<b>K42</b>										✓	✓	✓	✓	✓	✓
Concentricity of shaft extension in accordance with DIN 42955 Tolerance R	<b>L39</b>										✓	✓	✓	✓	✓	✓
Non-standard cylindrical shaft extension <sup>19)</sup>	<b>Y55 •</b> and identification code										✓	✓	✓	✓	✓	✓
<b>Heating and ventilation</b>																
Metal external fan <sup>20)</sup>	<b>K35</b>										✓	✓	✓	✓	✓	✓
Anti-condensation heaters for 230 V	<b>K45</b>										✓	✓	✓	✓	✓	✓
Anti-condensation heaters for 115 V	<b>K46</b>										✓	✓	✓	✓	✓	✓
Sheet metal fan cover	<b>L36</b>										✓	✓	✓	✓	✓	✓
Separately driven fan with non-standard voltage and/or frequency	<b>Y81 •</b> and identification code										–	–	✓	✓	✓	✓

5

For legend and footnotes, see Page 5/31.

# IEC Squirrel-Cage Motors

## Motors operating with frequency converters

### Special versions

Special versions	Additional identification code <b>-Z</b> with order code and plain text if required	Motor type frame size														
		56	63	71	80	90	100	112	132	160	180	200	225	250	280	315
<b>Self-ventilated motors with special insulation for voltages up to 690 V – Cast-iron series 1LG6</b>																
<b>1LG6 (cast-iron)</b>																
<b>Rating plate and extra rating plates</b>																
Second lubricating plate, supplied loose	<b>B06</b>															
Second rating plate, loose	<b>K31</b>															
Extra rating plate or rating plate with deviating rating plate data	<b>Y80 •</b> and identification code															
Extra rating plate with identification code	<b>Y82 •</b> and identification code															
Additional information on rating plate and on package label (max. of 20 characters)	<b>Y84 •</b> and identification code															
<b>Packaging, safety notes; documentation and test certificates</b>																
Acceptance test certificate 3.1 according to EN 10204	<b>B02</b>															
Operating instructions German/English enclosed in print	<b>B23</b>															
Connected in star for dispatch	<b>M32</b>															
Connected in delta for dispatch	<b>M33</b>															

- Standard version
- Without additional charge
- This order code only determines the price of the version – Additional plain text is required.
- O.R. Possible on request
- ✓ With additional charge
- Not possible

- 1) Evaluation with appropriate tripping unit (see Catalog LV 1) is recommended.
- 2) This option is not possible for frame sizes 225 to 315 in combination with the option "Insulated bearing cartridge" – order code **L27**.
- 3) In combination with the PTC thermistor option or anti-condensation heating option, please inquire before ordering.
- 4) Possible in combination with order code **L44** to **L49** or length specification in plain text.
- 5) A second shaft extension is not possible. Please inquire for mounted brakes. The order codes listed cannot be combined within the various technologies nor with each other within the same technology system. This applies for:
  - Modular technology – Basic versions
  - Modular technology – Combination of basic versions
- 6) For 1LG6 motors, order codes **G17**, **G26** and **H63** frame size 225 and above can also be combined with rotary pulse encoders, see the "Special technology" range.
- 7) The standard brake supply voltage is 230 V AC, 50/60 Hz. Other brake supply voltages are possible with order codes **C00** and **C01**.
- 8) Not necessary for 1LG6 motors because these motors are already noise optimized.
- 9) Not possible in combination with rotary pulse encoder HOG 9 D 1024I (order code **H72**, **H79**) and/or brake 2LM8 (used for motors up to and including frame size 225, order code **G26**).
- 10) Not possible in combination with brake 2LM8 (used for motors up to and including frame size 225, order code **G26**).
- 11) Supplied with the condensation drainage holes sealed at the drive end DE and non-drive end NDE (IP55, IP56, IP65). If condensation drainage holes are required in motors of the IM B6, IM B7 or IM B8 type of construction (feet located on side or top), it is necessary to relocate the bearing plates at the drive end (DE) and non-drive end (NDE) so that the condensation drainage holes situated between the feet on delivery are underneath.
- 12) Not necessary when a rotary pulse encoder is combined with a separately driven fan, because in this case the rotary pulse encoder is installed under the fan cover.
- 13) In connection with mountings, the respective technical data must be observed; request required.
- 14) Not possible for 2-pole 1LG6 motors, frame size 315 L in vertical types of construction; bearings for increased cantilever forces at vibration quantity level B available on request for 1LG6 motors. Not possible for 1LG6 motors in the combination "Concentricity of the shaft extension, coaxiality and linear movement in accordance with DIN 42955 Tolerance R for flange-mounting motors" – order code **K04**.
- 15) Additional charge for 2-pole motors. With 4-pole to 8-pole motors, standard version.
- 16) This option is not possible for frame sizes 225 to 315 in combination with the option "Installation of 2 PT 100 screw-in resistance thermometers (basic circuit) for rolling-contact bearings" – order code **A72**.
- 17) Can be combined with deep-groove bearings of series 60... 62... and 63... . Not possible with parallel roller bearings (e.g. bearings for increased cantilever forces, order code **K20**) brake or encoder fitting.
- 18) Possible for motors of frame size 315 and above in vertical types of construction or 2-pole for version with second shaft extension on request. Version with protective cover not possible.
- 19) When motors are ordered that have a longer or shorter shaft extension than normal, the required position and length of the featherkey way must be specified in a sketch. It must be ensured that only featherkeys in accordance with DIN 6885, Form A are permitted to be used. The featherkey way is positioned centrally on the shaft extension. The length is defined by the manufacturer normatively.
  - Not applicable for: Conical shafts, non-standard threaded journals, non-standard shaft tolerances, friction welded journals, extremely "thin" shafts, special geometry dimensions (e.g. square journals), hollow shafts.
  - Valid for non-standard shaft extensions DE or NDE. The featherkeys are supplied in every case.
  - For order codes **Y55** and **K16**:
    - Dimensions D and DA ≤ internal diameter of roller bearing (see dimension tables under "Dimensions")
    - Dimensions E and EA ≤ 2 x length E (normal) of the shaft extension
- 20) For 1LA5/6/7/9 motors and 1LG with metal external fan, converter-fed operation is permitted. The metal external fan is not possible in combination with the low-noise version – order code **K37** or **K38**.

# IEC Squirrel-Cage Motors

## Motors operating with frequency converters

### Accessories

#### Overview

##### *Slide rails with fixing bolts and tensioning screws to DIN 42923*

Slide rails are used to tension the belt of a machine easily and conveniently when a belt tightener is not available. They are fixed to the base using stone bolts or foundation blocks.

The assignment of slide rails to motor size can be found in DIN 42923. For motors of frame sizes 355 to 450, there are no standardized slide rails (please inquire).

Available from:  
Lütgert & Co. GmbH  
Postfach 42 51  
33276 Gütersloh, Germany  
Tel. +49 (0)5241-7407-0  
Fax +49 (0)5241-7407-90

<http://www.luetgert-antriebe.de>  
e-mail: [info@luetgert-antriebe.de](mailto:info@luetgert-antriebe.de)

##### *Foundation block acc. to DIN 799*

The foundation blocks are inserted into the stone foundation and embedded in concrete. They are used for fixing machines of medium size, slide rails, pedestal bearings, baseframes, etc. After the fixing bolts have been unscrewed, the machine can be dragged without it having to be lifted.

When the machine is initially installed, the foundation block that is bolted to the machine (without washers) and fitted with taper pins is not embedded with concrete until the machine has been fully aligned. In this case, the machine is positioned 2 to 3 mm lower. The difference in shaft height is compensated by inserting shims on final installation. The taper pins safeguard the exact position of the machine when it is repeatedly removed and replaced without the need for realignment.

Available from:  
Lütgert & Co. GmbH  
Postfach 42 51  
33276 Gütersloh, Germany  
Tel. +49 (0)5241-7407-0  
Fax +49 (0)5241-7407-90

<http://www.luetgert-antriebe.de>  
e-mail: [info@luetgert-antriebe.de](mailto:info@luetgert-antriebe.de)

##### *Taper pins to DIN 258 with threaded ends and constant taper lengths*

Taper pins are used for components that are repeatedly removed. The drilled hole is ground conical using a conical reamer until the pin can be pushed in by hand until the cone shoulder lies 3 to 4 mm above the rim of the hole.

It can then be driven in using a hammer until it is correctly seated. The pin is removed from the drilled hole by screwing on the nut and tightening it.

Standardized taper pins are available from general engineering suppliers.

Available from:  
Otto Roth GmbH & Co. KG  
Rutesheimer Straße 22  
70499 Stuttgart, Germany  
Tel. +49 (0)7 11-13880  
Fax +49 (0)7 11-1388233

<http://www.ottoroth.de>  
e-mail: [info@ottoroth.de](mailto:info@ottoroth.de)

##### *Couplings*

In most cases, the motor is connected to the driving machine through coupling.

Source of supply:  
Siemens contact partner – ordering from Catalog  
Siemens MD 10.1 "FLENDER Standard Couplings"

or

A. Friedr. Flender AG  
Kupplungswerk Mussum  
Industriepark Bocholt  
Schlavenhorst 100  
46395 Bocholt, Germany  
Tel. +49 (0)2871-922185  
Fax +49 (0)2871-922579

<http://www.flender.com>  
e-mail: [couplings@flender.com](mailto:couplings@flender.com)

##### *Mounting of encoder*

In the case of mounting by the customer.

##### *Options H79, H80*

Baumer Hübner GmbH  
Planufer 92b  
10967 Berlin, Germany  
Tel. +49 (0)30-69003-0  
Fax +49 (0)30-69003-104

<http://www.baumerhuebner.com>  
e-mail: [info@baumerhuebner.com](mailto:info@baumerhuebner.com)

##### *Option H78*

Leine & Linde (Deutschland) GmbH  
Bahnhofstraße 36  
73430 Aalen, Germany  
Tel. +49 (0)7361-78093-0  
Fax +49 (0)7361-78093-11

<http://www.leinelinde.com>  
e-mail: [info@leinelinde.se](mailto:info@leinelinde.se)

#### More information

##### *Spare motors and repair parts*

- Supply commitment for spare motors and repair parts following delivery of the motor
  - For up to 5 years, in the event of total motor failure, Siemens will supply a comparable motor with regard to the mounting dimensions and functions (the type series may vary).
  - Repair parts will be supplied for up to 5 years.
  - For up to 10 years, Siemens will provide information and will, if necessary, supply documentation for repair parts.
- When repair parts are ordered, the following details must be provided:
  - Designation and part number
  - Order No. and factory number of the motor

Example for ordering a fan cover 1LA7, frame size 160 M, 4-pole:

##### **Fan cover No. 7.40, 1LA7 163-4AA60, factory number J783298901018**

- For bearing types, see the "Introduction".
- Repair parts for 1MJ6, 1MJ7, 1MJ8, 1MJ1, 1ME8, 1ML8, 1LG8 motors and smoke-extraction motors are available on request.
- For standard components, a supply commitment does not apply.
- Support – Hotline  
In Germany  
Tel.: 0180/5050448

National telephone numbers can be found on the Internet page:  
<http://www.siemens.com/automation/service&support>

# IEC Squirrel-Cage Motors

## Motors operating with frequency converters

### Dimensions

#### Overview

##### Note

The following overall dimensions and dimension drawings are only applicable for self-ventilated 1LA7/1LA5 and 1LG6 motors with special insulation for voltages up to 690 V. For overall dimensions of 1LA8/1PQ8 motors with special insulation for voltages up to 690 V, see catalog part 3 "Non-standard motors".

For overall dimensions and dimension drawings for surface-cooled motors with standard insulation for voltages up to 500 V, see the relevant catalog part.

#### Overall dimensions

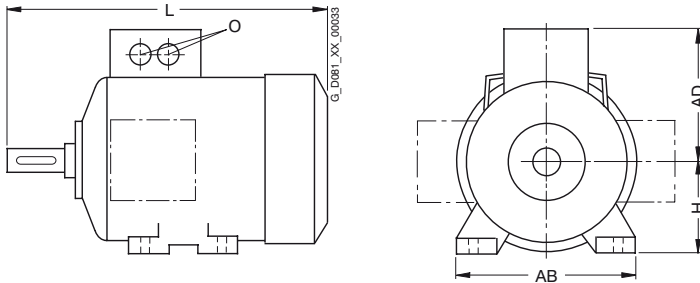

Frame size	Type	Number of poles	Dimensions				
			L	AD	H	AB	O
100 L	1LA7		372	135	100	196	2 x M32 x 1.5
112 M	1LA7		393	148	112	226	2 x M32 x 1.5
132 S/ 132 M	1LA7		452.5	167	132	256	2 x M32 x 1.5
160 M/ 160 L	1LA7		588	197	160	300	2 x M40 x 1.5
180 M/ 180 L	1LA5		712	258	180	339	2 x M40 x 1.5
	1LG6 183	2	720	262	180	339	2 x M40 x 1.5
	1LG6 183	4	669	262	180	339	2 x M40 x 1.5
	1LG6 186	4, 6, 8	720	262	180	339	2 x M40 x 1.5
200 L	1LA5		769.5	305	200	388	2 x M50 x 1.5
	1LG6 206		720	300	200	378	2 x M50 x 1.5
	1LG6 207		777	300	200	378	2 x M50 x 1.5
	1LG6 207	4, 8	720	300	200	378	2 x M50 x 1.5
225 S/ 225 M	1LA5		806	305	225	426	2 x M50 x 1.5
	1LA5	2	776	305	225	426	2 x M50 x 1.5
	1LG6 220	4, 8	789	325	225	436	2 x M50 x 1.5
	1LG6 223	2	819	325	225	436	2 x M50 x 1.5
	1LG6 223	4, 6, 8	849	325	225	436	2 x M50 x 1.5
	1LG6 228	2	869	325	225	436	2 x M50 x 1.5
	1LG6 228	4, 6	899	325	225	436	2 x M50 x 1.5

Frame size	Type	Number of poles	Dimensions				
			L	AD	H	AB	O
250 M	1LG6 253	2, 6, 8	887	392	250	490	2 x M63 x 1.5
	1LG6 253	4	957	392	250	490	2 x M63 x 1.5
	1LG6 258	2, 4, 6	957	392	250	490	2 x M63 x 1.5
280 S/ 280 M	1LG6 280	2, 4, 6, 8	960	432	280	540	2 x M63 x 1.5
	1LG6 283	2, 4	1070	432	280	540	2 x M63 x 1.5
	1LG6 283	6, 8	960	432	280	540	2 x M63 x 1.5
	1LG6 288	2, 4, 6	1070	432	280	540	2 x M63 x 1.5
315 S/ 315 M/ 315 L	1LG6 310	2	1072	500	315	610	2 x M63 x 1.5
	1LG6 310	4, 6, 8	1102	500	315	610	2 x M63 x 1.5
	1LG6 313	8	1102	500	315	610	2 x M63 x 1.5
	1LG6 313	2	1232	500	315	610	2 x M63 x 1.5
	1LG6 313	4, 6	1262	500	315	610	2 x M63 x 1.5
	1LG6 316	2	1232	500	315	610	2 x M63 x 1.5
	1LG6 316	4, 6, 8	1262	500	315	610	2 x M63 x 1.5
	1LG6 317	8	1262	500	315	610	2 x M63 x 1.5
	1LG6 317	2	1372	500	315	610	2 x M63 x 1.5
	1LG6 317	4, 6	1402	500	315	610	2 x M63 x 1.5
	1LG6 318	2	1372	651	315	610	2 x M63 x 1.5
	1LG6 318	4	1402	651	315	610	2 x M63 x 1.5
	1LG6 318	6, 8	1402	500	315	610	2 x M63 x 1.5

#### Notes on the dimensions

■ Dimension designations according to DIN EN 50347 and IEC 60072.

##### ■ Fits

The shaft extensions specified in the dimension tables (DIN 748) and centering spigot diameters (DIN EN 50347) are machined with the following fits:

Dimension designation	ISO fit	DIN ISO 286-2
D, DA	to 30	j6
	over 30 to 50	k6
	over 50	m6
N	to 250	j6
	over 250	h6
F, FA		h9
K		H17
S	Flange (FF)	H17

The drilled holes of couplings and belt pulleys should have an ISO fit of at least H7.

##### ■ Dimension tolerances

For the following dimensions, the admissible deviations are given below:

Dimension designation	Dimension	Admissible deviation
H	to 250	- 0.5
	over 250	- 1.0
E, EA		- 0.5

Keyways and feather keyways (dimensions GA, GC, F and FA) are made in compliance with DIN 6885 Part 1.

■ All dimensions are specified in mm.

# IEC Squirrel-Cage Motors

## Motors operating with frequency converters

### Dimensions

#### Dimensional drawings

Aluminum series 1LA7 and 1LA5, frame sizes 100 L to 225 M · with special insulation for voltages up to 690 V

#### Type of construction IM B3

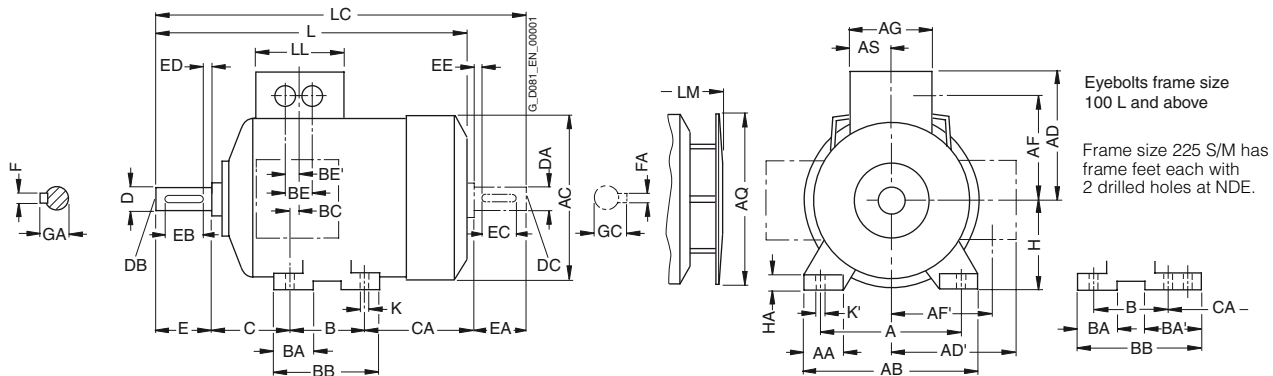

#### Types of construction IM B5 and IM V1

For flange dimensions, see Page 5/40 (Z = the number of retaining holes)

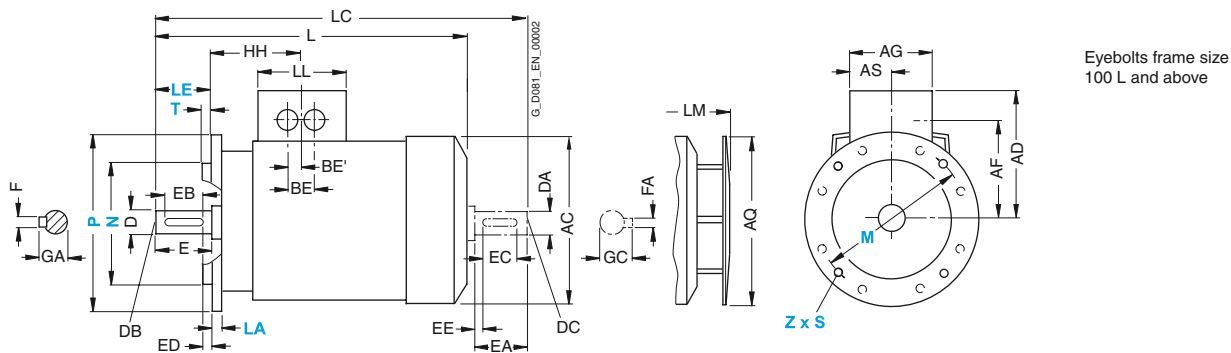

5

For motor		Dimension designation acc. to IEC																						
Frame size	Type	Number of poles	A	AA	AB	AC <sup>1)</sup>	AD <sup>2)</sup>	AD'	AF <sup>2)</sup>	AF'	AG <sup>2)</sup>	AQ	AS	B*	BA	BA'	BB	BC	BE <sup>2)</sup>	BE' <sup>2)</sup>	C	CA*	H	HA
100 L	1LA7 106	2, 4, 6, 8	160	42	196	203	135	163	78	123	120	170	60	140	47	-	176	39	42	21	63	125	100	12
	1LA7 107	4, 8																						
112 M	1LA7 113	2, 4, 6, 8	190	46	226	227	148	176	91	136	120	170	60	140	47	-	176	32	42	21	70	141	112	12
132 S	1LA7 130	2, 4, 6, 8	216	53	256	267	167	194	107	154	140	250	70	140	49	-	180	39	42	21	89	162.5	132	15
	1LA7 131	2																						
132 M	1LA7 133	4, 6, 8	216	53	256	267	167	194	107	154	140	250	70	178	49	-	218	39	42	21	89	124.5	132	15
	1LA7 134	6																						
160 M	1LA7 163	2, 4, 6, 8	254	60	300	320	197	226	127	183	165	250	82.5	210	57	-	256	52.5	54	27	108	183	160	18
	1LA7 164	2, 8																						
160 L	1LA7 166	2, 4, 6, 8	254	60	300	320	197	226	127	183	165	250	82.5	254	57	-	300	52.5	54	27	108	139	160	18
180 M	1LA5 183	2, 4	279	69.5	339	363	258	258	216	216	152	340	71	241	50	-	287	38	54	27	121	259	180	18
	1LA5 186	4, 6, 8	279	69.5	339	363	258	258	216	216	152	340	71	279	50	-	325	38	54	27	121	221	180	18
200 L	1LA5 206	2, 6	318	83	388	402	305	305	252	252	260	340	96	305	58.5	-	355	45	85	42.5	133	239	200	24
	1LA5 207	2, 4, 6, 8																						
225 S	1LA5 220	4, 8	356	103	426	402	305	305	252	252	260	340	96	286	58	83	361	36	85	42.5	149	248.5	225	24
225 M	1LA5 223	2	356	103	426	402	305	305	252	252	260	340	96	311	58	83	361	36	85	42.5	149	223.5	225	24
		4, 6, 8																						

\* This dimension is assigned in DIN EN 50347 to the frame size listed.

1) Measured across the bolt heads.

2) The values increase if the connection box is rotated or if a brake is mounted. Further information is provided by the dimension sheet generator in SD configurator.

# IEC Squirrel-Cage Motors

## Motors operating with frequency converters

**Dimensions**
**Dimensional drawings**
*Aluminum series 1LA7 and 1LA5, frame sizes 100 L to 225 M · with special insulation for voltages up to 690 V*
**Type of construction IM B35**

For flange dimensions, see Page 5/40 (Z = the number of retaining holes)

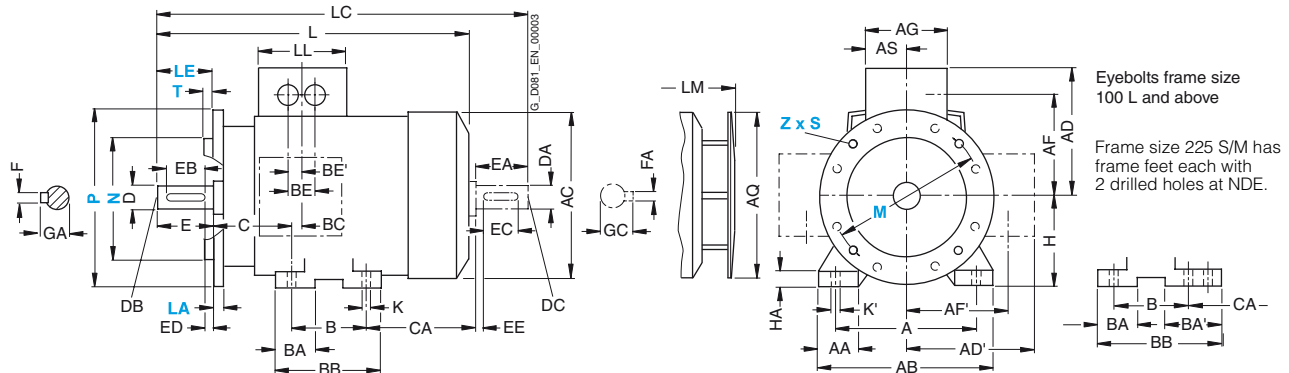
**Type of construction IM B14**

For flange dimensions, see Page 5/40 (Z = the number of retaining holes)

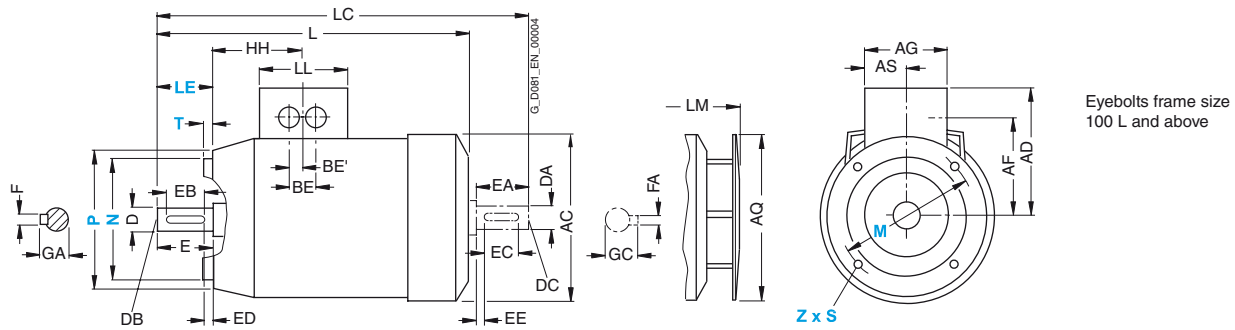

For motor		Dimension designation acc. to IEC										DE shaft extension				NDE shaft extension							
Frame size	Type	Number of poles	HH	K	K'	L	LC	LL	LM	D	DB	E	EB	ED	F	GA	DA	DC	EA	EC	EE	FA	GC
100 L	1LA7 106 1LA7 107	2, 4, 6, 8 4, 8	102	12	16	372	438	120	423.5	28	M10	60	50	5	8	31	24	M8	50	40	5	8	27
112 M	1LA7 113	2, 4, 6, 8	102	12	16	393	461	120	444.5	28	M10	60	50	5	8	31	24	M8	50	40	5	8	27
132 S	1LA7 130 1LA7 131 2	2, 4, 6, 8 2	128	12	16	452.5 <sup>1)</sup>	551.5	140	505 <sup>1)</sup>	38	M12	80	70	5	10	41	38	M12	80	70	5	10	41
132 M	1LA7 133 1LA7 134 6	4, 6, 8 6	128	12	16	452.5 <sup>1)</sup>	551.5	140	505 <sup>1)</sup>	38	M12	80	70	5	10	41	38	M12	80	70	5	10	41
160 M	1LA7 163 1LA7 164 2, 8	2, 4, 6, 8 2, 8	160.5	15	19	588	721	165	640.5	42	M16	110	90	10	12	45	42	M16	110	90	10	12	45
160 L	1LA7 166	2, 4, 6, 8	160.5	15	19	588	721	165	640.5	42	M16	110	90	10	12	45	42	M16	110	90	10	12	45
180 M	1LA5 183	2, 4	159	15	19	712	841	132	793.5	48	M16	110	100	5	14	51.5	48	M16	110	100	5	14	51.5
180 L	1LA5 186	4, 6, 8	159	15	19	712	841	132	793.5	48	M16	110	100	5	14	51.5	48	M16	110	100	5	14	51.5
200 L	1LA5 206 1LA5 207	2, 6 2, 4, 6, 8	178	19	25	769.5	897	192	850	55	M20	110	100	5	16	59	55	M20	110	100	5	16	59
225 S	1LA5 220	4, 8	184.5	19	25	806	933.5	192	887.5	60	M20	140	125	7.5	18	64	55	M20	110	100	5	16	59
225 M	1LA5 223	2 4, 6, 8	184.5	19	25	776 806	903.5 933.5	192	857.5 887.5	55 60	M20	110 140	100 125	5 7.5	16 18	59 64	55	M20	110	100	5	16	59

<sup>1)</sup> In a low-noise version, the dimension L is 8 mm greater and the dimension LM is 11.5 mm greater.

# IEC Squirrel-Cage Motors

## Motors operating with frequency converters

### Dimensions

#### Dimensional drawings

Cast-iron series 1LG6, frame sizes 180 M to 250 M · with special insulation for voltages up to 690 V

#### Type of construction IM B3

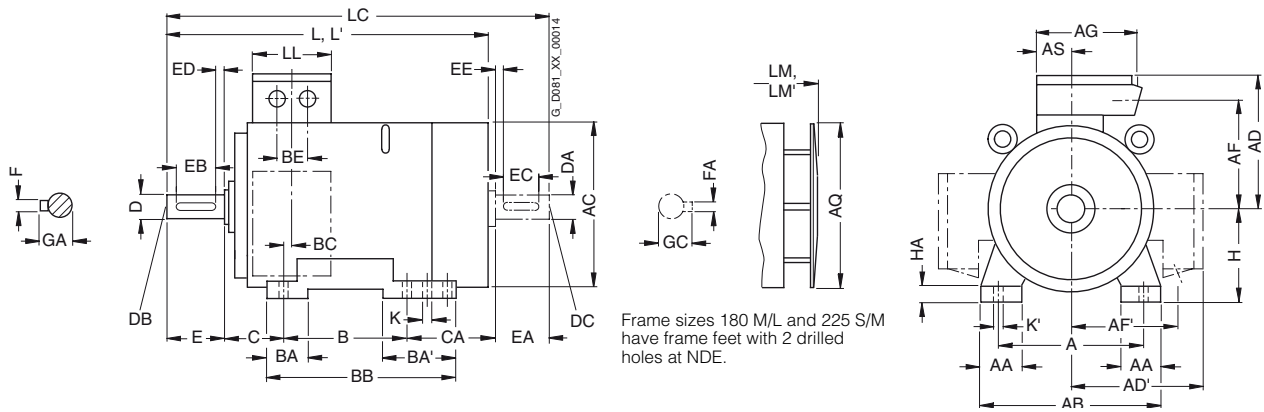

#### Types of construction IM B5 and IM V1

For flange dimensions, see Page 5/40 (Z = the number of retaining holes)

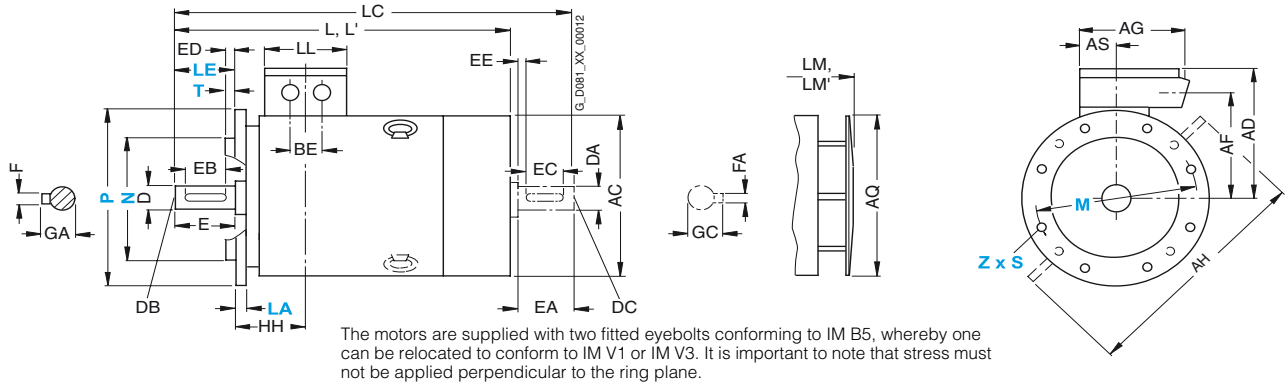

5

For motor			Dimension designation acc. to IEC																					
Frame size	Type	Number of poles	A	AA	AB	AC <sup>1)</sup>	AD	AD'	AF	AF'	AG	AH	AQ	AS	B*	BA	BA'	BB	BC	BE	C	CA*	H	HA
180 M	1LG6 183	2	279	65	339	363	262	262	220	220	152	452	340	71	241	70	111	328	36	54	121	253	180	20
		4																						
180 L	1LG6 186	4, 6, 8	279	65	339	363	262	262	220	220	152	452	340	71	279	70	111	328	36	54	121	215	180	20
200 L	1LG6 206	2, 6	318	70	378	402	300	300	247	247	260	512	340	96	305	80	80	355	63	85	133	177	200	25
		4, 8																						
225 S	1LG6 220	4, 8	356	80	436	442	325	325	272	272	260	556	425	96	286	85	110	361	47	85	149	218	225	34
225 M	1LG6 223	2	356	80	436	442	325	325	272	272	260	556	425	96	311	85	110	361	47	85	149	253	225	34
		4, 6, 8																						
	1LG6 228	2	356	80	436	442	325	325	272	272	260	556	425	96	311	85	110	361	47	85	149	303	225	34
250 M	1LG6 253	2	406	100	490	495	392	392	308	308	300	620	470	118	349	100	100	409	69	110	168	235	250	40
		4																						
	1LG6 258	2	406	100	490	495	392	392	308	308	300	620	470	118	349	100	100	409	69	110	168	305	250	40
		4, 6																			235			

\* This dimension is assigned in DIN EN 50347 to the frame size listed.

<sup>1)</sup> Measured across the bolt heads.



# IEC Squirrel-Cage Motors

## Motors operating with frequency converters

### Dimensions

#### Dimensional drawings

Cast-iron series 1LG6, frame sizes 180 M to 250 M · with special insulation for voltages up to 690 V

#### Type of construction IM B35

For flange dimensions, see Page 5/40 (Z = the number of retaining holes)

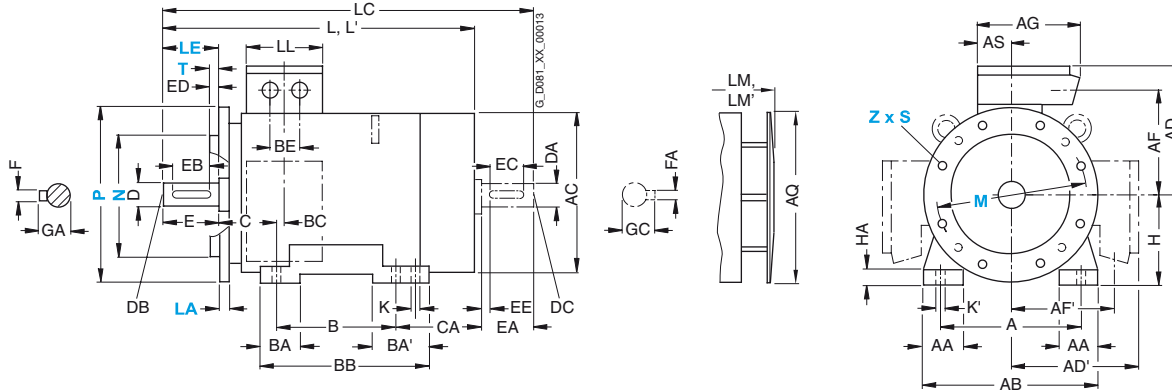

For motor		Number of poles	Dimension designation acc. to IEC							DE shaft extension					NDE shaft extension								
Frame size	Type		HH	K	K'	L	LC	LL	LM	D	DB	E	EB	ED	F	GA	DA	DC	EA	EC	EE	FA	GC
180 M	1LG6 183	2	157	15	19	720	835	132	810	48	M16	110	100	5	14	51.5	48	M16	110	100	5	14	51.5
		4				669	784	759															
180 L	1LG6 186	4, 6, 8	157	15	19	720	835	132	810	48	M16	110	100	5	14	51.5	48	M16	110	100	5	14	51.5
200 L	1LG6 206	2, 6	196	19	25	720	835	192	810	55	M20	110	100	5	16	59	55	M20	110	100	5	16	59
		4, 8				720	835	810															
225 S	1LG6 220	4, 8	196	19	25	789	903	192	889	60	M20	140	125	10	18	64	55	M20	110	100	5	16	59
		2				819	933	919															
225 M	1LG6 223	2	196	19	25	849	963	192	949	60	M20	140	125	10	18	64	55	M20	110	100	5	16	59
		4, 6, 8				869	983	969															
	1LG6 228	2	196	19	25	899	1013	192	999	60	M20	140	125	10	18	64	55	M20	110	100	5	16	59
	4, 6	899				1013	999																
250 M	1LG6 253	2	237	24	30	887	1002	236	987	60	M20	140	125	10	18	64	55	M20	110	100	5	16	59
		4				957	1102	1057															
	1LG6 258	2	237	24	30	887	1032	236	987	65	M20	140	125	10	18	69	60	M20	140	125	10	18	64
	4, 6	957				1102	1057	65	M20														

# IEC Squirrel-Cage Motors

## Motors operating with frequency converters

### Dimensions

#### Dimensional drawings

Cast-iron series 1LG6, frame sizes 280 S to 315 L · with special insulation for voltages up to 690 V

#### Type of construction IM B3

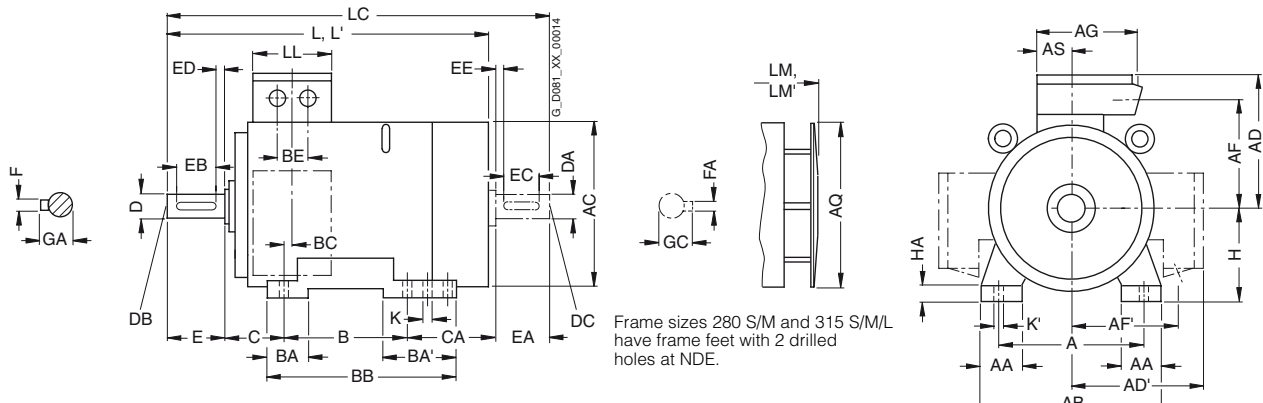

#### Types of construction IM B5 and IM V1

For flange dimensions, see Page 5/40 (Z = the number of retaining holes)

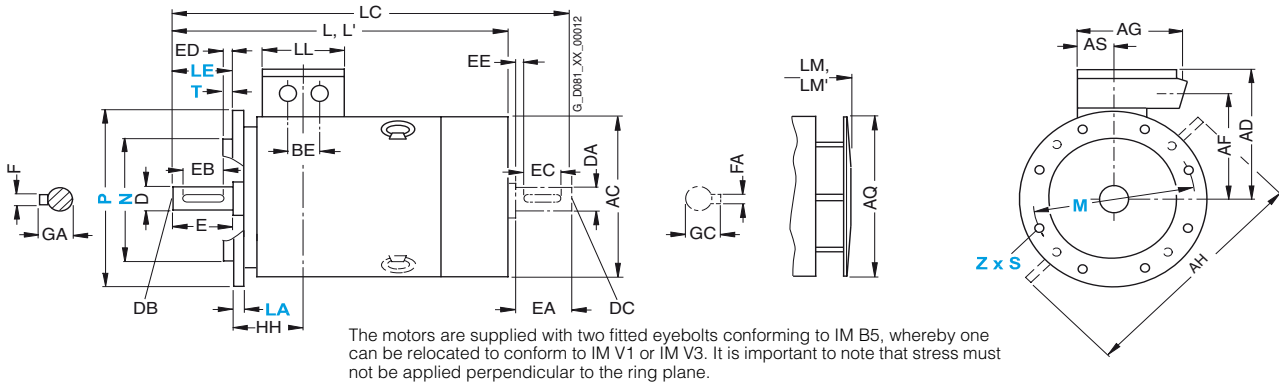

5

For motor	Frame size	Type	Number of poles	Dimension designation acc. to IEC																					
				A	AA	AB	AC <sup>1)</sup>	AD	AD'	AF	AF'	AG	AH	AQ	AS	B*	BA	BA'	BB	BC	BE	C	CA*	H	HA
280 S	1LG6 280	2	2	457	100	540	555	432	432	348	348	300	672	525	118	368	100	151	479	62	110	190	267	280	40
280 M	1LG6 283	2	4, 6, 8	457	100	540	555	432	432	348	348	300	672	525	118	419	100	151	479	62	110	190	326	280	40
			4	457	100	540	555	432	432	348	348	300	672	525	118	419	100	151	479	62	110	190	326	280	40
			6, 8	457	100	540	555	432	432	348	348	300	672	525	118	419	100	151	479	62	110	190	216	326	280
315 S	1LG6 310	2	2	508	120	610	610	500	500	400	400	380	780	590	154	406	125	176	527	69	110	216	315	315	50
	1LG6 310	4, 6, 8	4, 6, 8	508	120	610	610	500	500	400	400	380	780	590	154	457	125	176	527	69	110	216	264	315	50
315 M <sup>2)</sup>	1LG6 313	8	8	508	120	610	610	500	500	400	400	380	780	590	154	457	125	176	578	69	110	216	424	315	50
	1LG6 313	2	2	508	120	610	610	500	500	400	400	380	780	590	154	457	125	176	578	69	110	216	424	315	50
315 L <sup>2)</sup>	1LG6 313	4, 6	4, 6	508	120	610	610	500	500	400	400	380	780	590	154	508	125	176	578	69	110	216	373	315	50
	1LG6 316	2	2	508	120	610	610	500	500	400	400	380	780	590	154	508	125	176	578	69	110	216	373	315	50
	1LG6 316	4, 6	4, 6	508	120	610	610	500	500	400	400	380	780	590	154	508	125	176	578	69	110	216	513	315	50
	1LG6 316	8	8	508	120	610	610	500	500	400	400	380	780	590	154	508	125	176	578	69	110	216	513	315	50
	1LG6 317	2	2	508	120	610	610	500	500	400	400	380	780	590	154	508	125	176	578	69	110	216	513	315	50
	1LG6 317	4, 6	4, 6	508	120	610	610	500	500	400	400	380	780	590	154	508	125	176	578	69	110	216	513	315	50
	1LG6 317	8	8	508	120	610	610	500	500	400	400	380	780	590	154	508	125	176	578	69	110	216	513	315	50
	1LG6 318	2	2	508	120	610	610	651	651	524	524	470	780	590	165	508	125	176	648	69	135	216	513	315	50
1LG6 318	4	4	508	120	610	610	651	651	524	524	470	780	590	165	508	125	176	648	69	135	216	513	315	50	
1LG6 318	6, 8	6, 8	508	120	610	610	500	500	400	400	380	780	590	165	508	125	176	648	69	110	216	513	315	50	

\* This dimension is assigned in DIN EN 50347 to the frame size listed.

1) Measured across the bolt heads.

2) With order codes for connection box positions (K09, K10, K11) only fitted feet with 3 drilled holes with dimension "B" (406, 457 and 508 mm). BB will then be 666 mm.

# IEC Squirrel-Cage Motors

## Motors operating with frequency converters

### Dimensions

#### Dimensional drawings

Cast-iron series 1LG6, frame sizes 280 S to 315 L · with special insulation for voltages up to 690 V

#### Type of construction IM B35

For flange dimensions, see Page 5/40 (Z = the number of retaining holes)

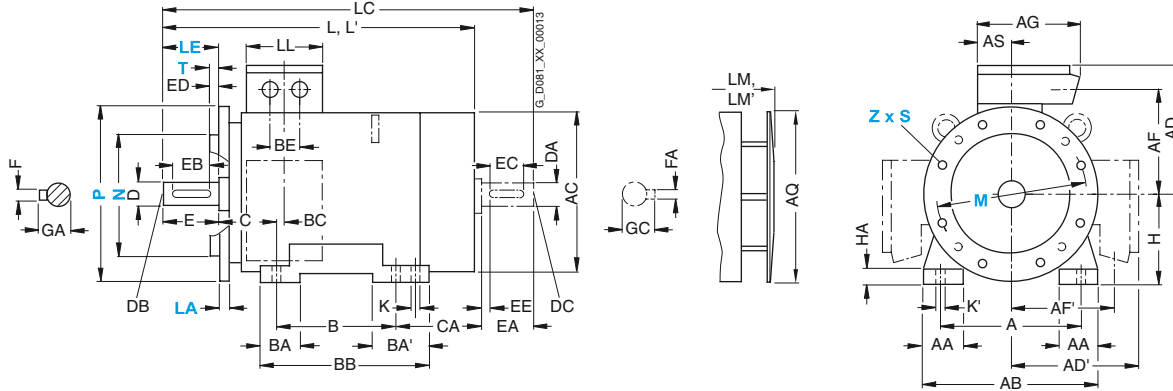

For motor			Dimension designation acc. to IEC							DE shaft extension				NDE shaft extension									
Frame size	Type	Number of poles	HH	K	K'	L	LC	LL	LM	D	DB	E	EB	ED	F	GA	DA	DC	EA	EC	EE	FA	GC
280 S	1LG6 280	2	252	24	30	960	1105	236	1070	65	M20	140	125	10	18	69	60	M20	140	125	10	18	64
		4, 6, 8								75	M20	140	125	10	20	79.5	65	M20	140	125	10	18	69
280 M	1LG6 283	2	252	24	30	1070	1215	236	1180	65	M20	140	125	10	18	69	60	M20	140	125	10	18	64
		4								75	M20	140	125	10	20	79.5	65	M20	140	125	10	18	69
	1LG6 288	6, 8				960	1105		1070	75	M20	140	125	10	20	79.5	65	M20	140	125	10	18	69
		2	252	24	30	1070	1215	236	1180	65	M20	140	125	10	18	69	60	M20	140	125	10	18	64
		4, 6								75	M20	140	125	10	20	79.5	65	M20	140	125	10	18	69
315 S	1LG6 310	2	285	28	35	1072	1217	307	1182	65	M20	140	125	10	18	69	60	M20	140	125	10	18	64
	1LG6 310	4, 6, 8								1102	1247		1212	80	M20	170	140	25	22	85	70	M20	140
315 M	1LG6 313	8	285	28	35	1102	1247	307	1212	80	M20	170	140	25	22	85	70	M20	140	125	10	20	74.5
		2								65	M20	140	125	10	18	69	60	M20	140	125	10	18	64
	1LG6 313	4, 6				1262	1407		1372	80	M20	170	140	25	22	85	70	M20	140	125	10	20	74.5
315 L	1LG6 316	2	285	28	35	1232	1377	307	1342	65	M20	140	125	10	18	69	60	M20	140	125	10	18	64
		4, 6								80	M20	170	140	25	22	85	70	M20	140	125	10	20	74.5
	1LG6 316	8				1262	1407		1372	80	M20	170	140	25	22	85	70	M20	140	125	10	20	74.5
	1LG6 317	2	285	28	35	1372	1517	307	1482	65	M20	140	125	10	18	69	60	M20	140	125	10	18	64
	1LG6 317	4, 6								1402	1547		1512	80	M20	170	140	25	22	85	70	M20	140
	1LG6 317	8				1262	1407		1372	80	M20	170	140	25	22	85	70	M20	140	125	10	20	74.5
	1LG6 318	2	285	28	35	1372	1517	330	1482	65	M20	140	125	10	18	69	60	M20	140	125	10	18	64
	1LG6 318	4								1402	1547		1512	80 <sup>1)</sup>	M20	170	140	25	22	85	70	M20	140
	1LG6 318	6, 8						307	80	M20	170	140	25	22	85	70	M20	140	125	10	20	74.5	

<sup>1)</sup> Diameters up to 90 mm are possible.

# IEC Squirrel-Cage Motors

## Motors operating with frequency converters

### Dimensions

#### Dimensional drawings

##### Flange dimensions

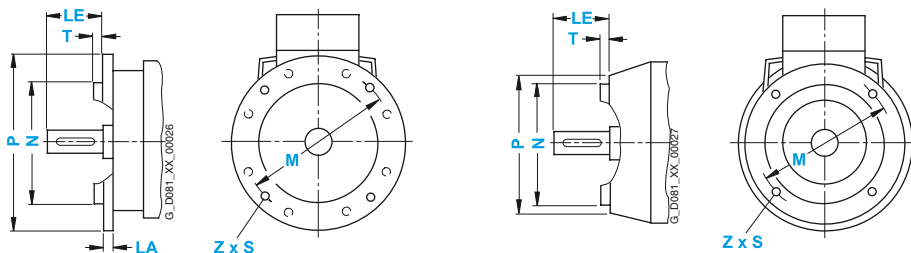

In DIN EN 50347, the frame sizes are allocated flange FF with through holes and flange FT with tapped holes. The designation of flange A and C according to DIN 42948 (invalid since 09/2003) are also listed for information purposes. See the table below. (Z = the number of retaining holes)

Frame size	Type of construction	Flange type	Flange with through holes (FF/A) tapped holes (FT/C)	Acc. to DIN EN 50347	Acc. to DIN 42948	Dimension designation acc. to IEC							
						LA	LE	M	N	P	S	T	Z
<b>100 L</b>	IM B5, IM B35, IM V1, IM V3	Flange	<b>FF 215</b>		A 250	11	60	215	180	250	14.5	4	4
	IM B14, IM B34, IM V18, IM V19	Standard flange	<b>FT 130</b>		C 160	–	60	130	110	160	M8	3.5	4
	IM B14, IM B34, IM V18, IM V19	Special flange	<b>FT 165</b>		C 200	–	60	165	130	200	M10	3.5	4
<b>112 M</b>	IM B5, IM B35, IM V1, IM V3	Flange	<b>FF 215</b>		A 250	11	60	215	180	250	14.5	4	4
	IM B14, IM B34, IM V18, IM V19	Standard flange	<b>FT 130</b>		C 160	–	60	130	110	160	M8	3.5	4
	IM B14, IM B34, IM V18, IM V19	Special flange	<b>FT 165</b>		C 200	–	60	165	130	200	M10	3.5	4
<b>132 S, 132 M</b>	IM B5, IM B35, IM V1, IM V3	Flange	<b>FF 265</b>		A 300	12	80	265	230	300	14.5	4	4
	IM B14, IM B34, IM V18, IM V19	Standard flange	<b>FT 165</b>		C 200	–	80	165	130	200	M10	3.5	4
	IM B14, IM B34, IM V18, IM V19	Special flange	<b>FT 215</b>		C 250	–	80	215	180	250	M12	4	4
<b>160 M, 160 L</b>	IM B5, IM B35, IM V1, IM V3	Flange	<b>FF 300</b>		A 350	13	110	300	250	350	18.5	5	4
	IM B14, IM B34, IM V18, IM V19	Standard flange	<b>FT 215</b>		C 250	–	110	215	180	250	M12	4	4
	IM B14, IM B34, IM V18, IM V19	Special flange	<b>FT 265</b>		C 300	–	110	265	230	300	M12	4	4
<b>180 M, 180 L</b>	IM B5, IM V1, IM V3	Flange	<b>FF 300</b>		A 350	13	110	300	250	350	18.5	5	4
<b>200 L</b>	IM B5	Flange	<b>FF 350</b>		A 400	15	110	350	300	400	18.5	5	4
<b>225 S, 225 M</b> 2-pole 4-pole to 8-pole	IM B5, IM V1, IM V3	Flange	<b>FF 400</b>		A 450	16	110	400	350	450	18.5	5	8
<b>250 M</b>	IM B5, IM V1, IM V3	Flange	<b>FF 500</b>		A 550	18	140	500	450	550	18.5	5	8
<b>280 S, 280 M</b>	IM B5, IM V1, IM V3	Flange	<b>FF 500</b>		A 550	18	140	500	450	550	18.5	5	8
<b>315 S, 315 M, 315 L</b> 2-pole 4-pole to 8-pole	IM B5, IM V1, IM V3	Flange	<b>FF 600</b>		A 660	22	140	600	550	660	24	6	8

#### More information

##### Dimension sheet generator (part of the SD configurator)

A dimensional drawing can be created in the SD configurator for every configurable motor. A dimension drawing can be requested for every other motor.

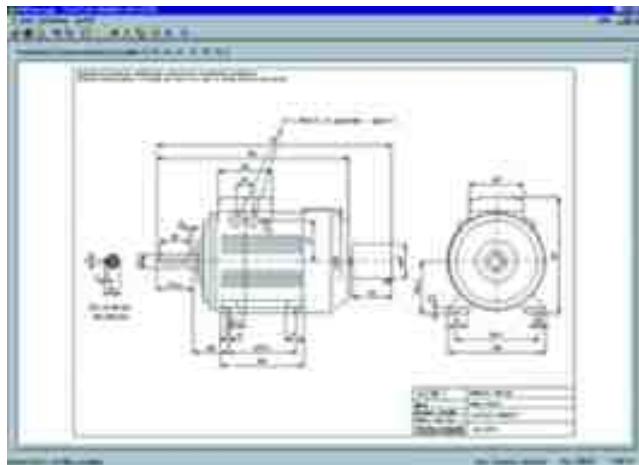

When a complete Order No. is entered with or without order codes, a dimension drawing can be called up under the "Documentation" tab.

These dimensional drawings can be presented in different views and sections and printed.

The corresponding dimension sheets can be exported, saved and processed further in DXF format (interchange/import format for CAD systems) or as bitmap graphics.

The SD configurator has been integrated into the electronic Catalog CA 01 as a selection aid (for more information, see catalog part 11 "Appendix", "Selection tool SD configurator").

The interactive Catalog CA 01 can be ordered from your local Siemens sales representative or on the Internet at

<http://www.siemens.com/automation/CA01>

At this address, you will also find links to Tips & Tricks and to downloads for function or content updates.

Order number for CA 01 10/2008, english international:  
DVD: E86060-D4001-A510-C7-7600

# Pump motors



<b>6/2</b>	<b>Orientation</b>
6/2	Overview
6/2	Benefits
6/2	Application
6/2	More information
<b>6/3</b>	<b>Surface-cooled motors up to frame size 315 L</b>
	<b>Aluminum and cast-iron housing</b>
6/3	Overview
<b>6/3</b>	<b>Surface-cooled motors frame size 315 and above</b>
	<b>Cast-iron housing</b>
6/3	Overview
<b>6/3</b>	<b>Special versions</b>
6/3	Overview
<b>6/4</b>	<b>Accessories</b>
6/4	Overview
<b>6/4</b>	<b>Dimensions</b>
6/4	Overview

# IEC Squirrel-Cage Motors

## Pump motors

### Orientation

### Overview



Pump motors are motors specially designed for use in various pump applications that can either be driven directly or through a belt drive.

The different application areas and types of construction of the pumps demand special technical characteristics of the motors and compactness through

- Using motors with increased output
- Reinforced bearings and use of a located bearing at the drive end (DE) of the motor
- Special materials for shafts, lubricants and seals as well as special flanges and special housings; these are possible on request

For converter-fed operation, winding monitoring through embedded KTY 84-130 temperature sensors is recommended as well as insulated bearings in the case of large output ranges.

### Benefits

The pump motors offer the user a number of advantages and benefits:

- Pump motors with located bearings at the drive end of the motor and with embedded thermistors can, in most cases, be supplied from stock
- Motors with increased efficiency to CEMEP EFF 1 or EPACT lead to significant energy savings under typical continuous duty
- Under converter-fed operation, by setting the precise speed and therefore the operating point, a considerable energy saving can be achieved combined with reduced stress on the plant
- The motors are suitable, in general, for mains-fed operation up to 690 V and converter-fed operation up to 460 V (with motor series 1LA8 to 500 V) (voltage rise times  $t_s > 0.1$  ms)
- Extensive experience is available in customized applications especially with regard to special flanges and special bearings

### Application

Pump motors are particularly suitable for the following pump types:

- Close-coupled pumps
- Industrial pumps
- Submersible pumps

With regard to the ambient conditions of the pump motors, it is important to ensure that the motor is located outside the pumped medium, i.e. the motor must be selected in accordance with the degree of protection. Further requirements are available on request.

### More information

For more information, please contact your local Siemens contact – see “Siemens contacts worldwide” in the Appendix.

# IEC Squirrel-Cage Motors

## Pump motors

Surface-cooled motors up to frame size 315 L  
Aluminum and cast-iron housing

### Overview

Recommended motor types:

- Self-ventilated motors with improved efficiency according to CEMEP EFF 2 – Aluminum series 1LA7 and 1LA5 in the output range from 0.06 to 45 kW
- Self-ventilated motors with improved efficiency according to CEMEP EFF2 – Aluminum series 1LE1 in the output range from 0.3 to 22 kW
- Self-ventilated motors with improved efficiency according to CEMEP EFF 2 – Cast-iron series 1LA6 and 1LG4 in the output range from 0.75 to 200 kW
- Self-ventilated motors with high efficiency according to CEMEP EFF1 – Aluminum series 1LA9 in the output range from 0.06 to 37 kW
- Self-ventilated motors with high efficiency according to CEMEP EFF1 – Aluminum series 1LE1 in the output range from 0.75 to 18.5 kW
- Self-ventilated motors with increased output – Cast-iron series 1LG4 in the output range from 15 to 100 kW
- Self-ventilated motors with improved efficiency according to CEMEP EFF2 with increased output – Aluminum series 1LE1 in the output range from 2.2 to 22 kW
- Self-ventilated motors with increased output – Aluminum series 1LA9 with outputs from 0.14 to 53 kW
- Self-ventilated motors with high efficiency according to CEMEP EFF1 with increased output – Aluminum series 1LE1 in the output range from 2.2 to 22 kW

Recommended specifications:

Most applications require a non-variable speed, i.e. it is sufficient to feed the drive motors with a fixed, unchanging rated frequency. In an ever-increasing number of applications, it is necessary to match the pump to the overall plant accurately (based on the pump characteristic). The pumps must respond quickly to changing conditions in the plant, supplying the drive motors with a variable rated frequency (converter-fed operation) is desirable.

Pole-changing motors can also be used. In this way, coarse adaptation of the pump characteristic can be achieved (in accordance with the possible motor speeds). For information about adapting the drive motors to the requirements of the pump with reference to the type of construction (e.g. flange, feet or special) as well as for a number of other options, see "Special versions".

For technical specifications, selection and ordering data and "Special versions", see catalog parts 1 "New Generation 1LE1/1PC1" and 2 "Standard motors up to frame size 315 L".

Surface-cooled motors frame size 315 and above  
Cast-iron housing

### Overview

Recommended motor types:

- Non-standard motors for mains-fed and converter-fed operation, cast-iron series 1LA8, with outputs from 160 to 1000 kW

For technical specifications and selection and ordering data, see catalog part 3 "Non-standard motors frame size 315 and above".

Special versions

### Overview

#### Recommended special versions for mains-fed and converter-fed operation

- Motor protection with PTC thermistors with 3 embedded temperature sensors for tripping – Order code **A11** for 1LE1 – 15th position of the Order No. letter **B**
- Located bearing at drive-end (DE) of motor – Order code **K94** for 1LE1 – order code **L20**
- Insulated bearing cartridge at non-drive-end (NDE) – Order code **L27**
- Bearings for increased cantilever forces – Order code **K20** for 1LE1 – order code **L22**
- Screwed-on feet for type of construction IM B35 frame size 112 and above in standard version or order code **K11** for 1LE1 – 16th position of the Order No. digit **4**

#### Pump version from stock – Order code X66

The pump version from stock comprises 3 embedded temperature sensors for tripping (order code **A11**), located bearing at drive-end (DE) of the motor (order code **K94**) as well as screwed-on feet (for type of construction IM B35 frame size 112 and above in standard version or order code **K11**) and is defined for the following motors:

- Self-ventilated motors with improved efficiency – Aluminum series 1LA7, 2-pole and 4-pole – Output range 0.25 to 18.5 kW
- Self-ventilated motors with improved efficiency – Cast-iron series 1LG4, 2-pole and 4-pole – Output range 18.5 to 37 kW

If other special versions are required, order codes **A11+K94+K11**, that are included in **X66**, must be specified individually in the order.

# IEC Squirrel-Cage Motors

## Pump motors

### Special versions

#### Overview (continued)

*Pump motors that can be supplied from stock according to CEMEP "Improved Efficiency" EFF 2, IP55 degree of protection, 50/60 Hz and temperature class F for a service factor of 1.1 with order code X66.*

Certified in accordance with	Rated output at 50 Hz	Frame size	Efficiency Class acc. to CEMEP	Pump version for		Voltage:		Voltage:		Voltage:		
				Order No. (additional charge)	Order code	230 VΔ / 400 VY, 50 Hz, 460 VY, 60 Hz	Order No. (additional charge)	Order code	400 VΔ / 690 VY, 50 Hz, 460 VY, 60 Hz	Order No. (additional charge)	Order code	400 VΔ / 690 VY, 50 Hz, 460 VY, 60 Hz
				Type:			Type:			Type:		
				IM B5, IM V1 without protective cover IM V3			IM B5, IM V1 without protective cover IM V3			IM B35		
<b>3000 rpm, 2-pole</b>												
CCC	0.75	80 M		<b>1LA7 080-2AA11-Z</b>	<b>X66</b>	–	–	–	–	–	–	–
CCC	1.1		EFF 2	<b>1LA7 083-2AA11-Z</b>	<b>X66</b>	–	–	–	–	–	–	–
CCC	1.5	90 S	EFF 2	<b>1LA7 090-2AA11-Z</b>	<b>X66</b>	–	–	–	–	–	–	–
CCC	2.2	90 L	EFF 2	<b>1LA7 096-2AA11-Z</b>	<b>X66</b>	–	–	–	–	–	–	–
	<b>3</b>	100 L	EFF 2	–	–	–	<b>1LA7 106-2AA61-Z</b>	<b>X66</b>	–	–	–	–
	<b>4</b>	112 M	EFF 2	–	–	–	<b>1LA7 113-2AA61-Z</b>	<b>X66</b>	–	–	–	–
	<b>5.5</b>	132 S	EFF 2	–	–	–	–	–	–	<b>1LA7 130-2AA66-Z</b>	<b>X66</b>	–
	<b>7.5</b>		EFF 2	–	–	–	–	–	–	<b>1LA7 131-2AA66-Z</b>	<b>X66</b>	–
	<b>11</b>	160 M	EFF 2	–	–	–	–	–	–	<b>1LA7 163-2AA66-Z</b>	<b>X66</b>	–
	<b>15</b>		EFF 2	–	–	–	–	–	–	<b>1LA7 164-2AA66-Z</b>	<b>X66</b>	–
	<b>18.5</b>	160 L	EFF 2	–	–	–	–	–	–	<b>1LA7 166-2AA66-Z</b>	<b>X66</b>	–
	<b>22</b>	180 M	EFF 2	–	–	–	–	–	–	<b>1LG4 183-2AA66-Z</b>	<b>X66</b>	–
	<b>30</b>	200 L	EFF 2	–	–	–	–	–	–	<b>1LG4 206-2AA66-Z</b>	<b>X66</b>	–
	<b>37</b>		EFF 2	–	–	–	–	–	–	<b>1LG4 207-2AA66-Z</b>	<b>X66</b>	–
<b>1500 rpm, 4-pole</b>												
CCC	0.25	71 M		<b>1LA7 070-4AB11-Z</b>	<b>X66</b>	–	–	–	–	–	–	–
CCC	0.37			<b>1LA7 073-4AB11-Z</b>	<b>X66</b>	–	–	–	–	–	–	–
CCC	0.55	80 M		<b>1LA7 080-4AA11-Z</b>	<b>X66</b>	–	–	–	–	–	–	–
CCC	0.75			<b>1LA7 083-4AA11-Z</b>	<b>X66</b>	–	–	–	–	–	–	–
CCC	1.1	90 S	EFF 2	<b>1LA7 090-4AA11-Z</b>	<b>X66</b>	–	–	–	–	–	–	–
	<b>1.5</b>	90 L	EFF 2	<b>1LA7 096-4AA11-Z</b>	<b>X66</b>	–	–	–	–	–	–	–
	<b>2.2</b>	100 L	EFF 2	<b>1LA7 106-4AA11-Z</b>	<b>X66</b>	–	–	–	–	–	–	–
	<b>3</b>		EFF 2	–	–	–	<b>1LA7 107-4AA61-Z</b>	<b>X66</b>	–	–	–	–
	<b>4</b>	112 M	EFF 2	–	–	–	<b>1LA7 113-4AA61-Z</b>	<b>X66</b>	–	–	–	–
	<b>5.5</b>	132 S	EFF 2	–	–	–	–	–	–	<b>1LA7 130-4AA66-Z</b>	<b>X66</b>	–
	<b>7.5</b>	132 M	EFF 2	–	–	–	–	–	–	<b>1LA7 133-4AA66-Z</b>	<b>X66</b>	–
	<b>11</b>	160 M	EFF 2	–	–	–	–	–	–	<b>1LA7 163-4AA66-Z</b>	<b>X66</b>	–
	<b>15</b>		EFF 2	–	–	–	–	–	–	<b>1LA7 166-4AA66-Z</b>	<b>X66</b>	–
	<b>18.5</b>	180 M	EFF 2	–	–	–	–	–	–	<b>1LG4 183-4AA66-Z</b>	<b>X66</b>	–
	<b>22</b>	180 L	EFF 2	–	–	–	–	–	–	<b>1LG4 186-4AA66-Z</b>	<b>X66</b>	–
	<b>30</b>	200 L	EFF 2	–	–	–	–	–	–	<b>1LG4 207-4AA66-Z</b>	<b>X66</b>	–

– Pump version (order code **X66**) not supplied from stock.

CCC (China Compulsory Certification) for export to China:

The motors supplied from stock marked with "CCC" include the order code **D01**; i.e. the "CCC" logo complete with "Factory code" is indicated on the rating plate and on the packaging.

#### Other special versions

For other special versions, see catalog parts 2 "Standard motors up to frame size 315 L" and 3 "Non-standard motors frame size 315 and above".

### Accessories

#### Overview

See catalog parts 1 "New Generation 1LE1/1PC1", 2 "Standard motors frame size 315 L and above" and 3 "Non-standard motors frame size 315 and above".

### Dimensions

#### Overview

See dimensions catalog parts 2 "Standard motors frame size 315 L and above" and 3 "Non-standard motors frame size 315 and above".



# Fan motors



<b>7/2</b>	<b>Orientation</b>
7/2	Overview
7/2	Benefits
7/2	Application
7/3	Technical specifications
7/4	Selection and ordering data
7/5	More information
<b>7/6</b>	<b>Self-ventilated motors in pole-changing version Aluminum series 1LA7 and 1LA5</b>
7/6	Selection and ordering data
<b>7/14</b>	<b>Self-ventilated motors in pole-changing version Cast-iron series 1LG4</b>
7/14	Selection and ordering data
<b>7/20</b>	<b>Forced-air cooled motors without external fan and fan cover with improved degree of efficiency Aluminum series 1PP7 and 1PP5</b>
7/20	Selection and ordering data
<b>7/24</b>	<b>Forced-air cooled motors without external fan and fan cover with improved degree of efficiency Cast-iron series 1PP4</b>
7/24	Selection and ordering data
<b>7/28</b>	<b>Forced-air cooled motors without external fan and fan cover with increased output Cast-iron series 1PP4</b>
7/28	Selection and ordering data
<b>7/30</b>	<b>Special versions</b>
7/30	Overview
7/30	Selection and ordering data
7/30	• Voltages
7/33	• Types of construction
7/34	• Options
<b>7/53</b>	<b>Accessories</b>
7/53	Overview
7/54	More information
<b>7/55</b>	<b>Dimensions</b>
7/55	Overview
7/56	Dimensional drawings
7/65	More information

# IEC Squirrel-Cage Motors

## Fan motors

### Orientation

#### Overview

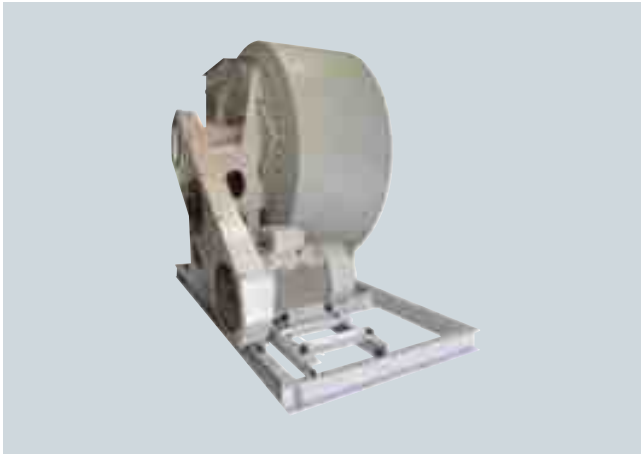

The fan motors are suitable for driving fans. The fan wheel can be located directly on the motor shaft or the fan shaft can be coupled with the motor shaft over a coupling or over a belt drive.

For fans with a belt drive, it is important to note the cantilever forces that are applied to the motor.

The different application areas for the fans demand special technical characteristics of the motors, such as:

- The use of reinforced bearings and a located bearing at the drive-end (DE) of the motor, especially with belt drive
- In confined spaces, it is recommended that the motor is ordered with the connection box located at the non-drive end (NDE) or with protruding cable ends instead of a connection box
- For flange types of construction with the shaft extension pointing upwards (e.g. IM V6) and when condensation is a possibility, a flange drainage hole is recommended
- For converter-fed operation, winding monitoring through embedded KTY 84-130 temperature sensors is recommended as well as insulated bearings in the case of large output ranges.

The resonance of mountings and reactions from driven machines can cause high levels of vibration in the overall equipment unit. This has a significant effect on the expected service life of the bearing.

For evaluation of these vibrations, vibration levels N, R and S are used in accordance with DIN EN 60034-14 (corresponding to evaluation zones A and B according to ISO 10816).

Note:

For information about motors according to EN 12101-3 for driving smoke extraction fans, see "Smoke extraction motors".

#### Benefits

The fan motors offer the user numerous advantages:

- Reduced construction volume and therefore lower weight thanks to motors with increased output
- Uniform forced-air cooled motor series 1PP from 0.09 to 200 kW as well as forced-air cooled motor series 1LE1 with order code F90
- Motors with increased efficiency to CEMEP EFF 1 or EPACT lead to significant energy savings under typical continuous duty; efficiency requirements that exceed this are possible on request
- Under converter-fed operation, by setting the precise speed and therefore the operating point, a considerable energy saving can be achieved combined with reduced stress on the plant
- The motors are suitable, in general, for mains-fed operation up to 690 V and converter-fed operation up to 460 V (voltage rise times  $t_s > 0.1$  ms)
- Extensive experience is available in customized applications especially with regard to special bearing design.

#### Application

The fan motors are mainly used to drive fans:

- Axial-flow fans
- Radial-flow fans
- Side channel compressor

### Technical specifications

Necessary minimum cooling air flow in standard duty

Frame size	1LA7/ 1PP7	1LA5/ 1PP5	Required cooling air flow for number of poles			
			2, 4/2 m <sup>3</sup> /min	4, 6/4, 8/4, 8/6/4 m <sup>3</sup> /min	6 m <sup>3</sup> /min	8 m <sup>3</sup> /min
63	X		0.83	0.41	0.28	–
71	X		1.40	0.70	0.47	0.35
80	X		1.74	0.90	0.60	0.44
90	X		3.12	1.56	1.08	0.78
100	X		3.96	1.86	1.26	0.93
112	X		4.98	3.00	1.98	1.50
132	X		8.04	5.04	3.36	2.52
160	X		12.90	9.54	6.36	4.80
180		X	10.98	10.98	7.27	5.44
200		X	15.12	13.02	8.58	6.36

Frame size	1PP4	Required cooling air flow for number of poles			
		2 m <sup>3</sup> /min	4 m <sup>3</sup> /min	6 m <sup>3</sup> /min	8 m <sup>3</sup> /min
180	X	12.0	13.0	8.5	6.5
200	X	20.5	17.0	11.0	8.0
225	X	20.5	18.5	12.5	9.5
250	X	25.5	22.5	17.0	12.5
280	X	24.5	28.0	21.5	16.0
315	X	47.0	36.0	26.5	19.0

In the motor version without an integrated fan (1PP5, 1PP7 and 1PP4), the motor is located in the air flow of the ventilator to be driven which must drive the minimum cooling air flow over the motor housing. For a faster air flow, the operating temperature of the motor can be reduced.

# IEC Squirrel-Cage Motors

## Fan motors

### Orientation

#### Selection and ordering data

*Preliminary selection of the motor according to motor type/series, speed or number of poles, frame size, rated output, rated torque, rated speed and rated current*

Self-ventilated motors in pole-changing version

Speed	Frame size	Rated output	Rated speed	Rated torque	Rated current at 400 V	Detailed selection and ordering data Page
rpm		kW	rpm	Nm	A	
<b>Aluminum series 1LA7 and 1LA5</b>						
<b>1500/3000, 4/2-pole</b>	<b>80 M ... 200 L</b>	0.15 ... 17	1385 ... 2930	1 ... 55	0.39 ... 31	<b>7/6 ... 7/7</b>
<b>1000/1500, 6/4-pole</b>	<b>80 M ... 200 L</b>	0.1 ... 26	680 ... 1470	1.4 ... 182	0.57 ... 52	<b>7/8 ... 7/9</b>
<b>750/1500, 8/4-pole</b>	<b>80 M ... 200 L</b>	0.12 ... 28	930 ... 1470	1.2 ... 170	0.51 ... 49	<b>7/10 ... 7/11</b>
<b>750/1000/1500, 8/6/4-pole</b>	<b>90 S ... 200 L</b>	0.15 ... 22	700 ... 980	2 ... 143	0.72 ... 42	<b>7/12 ... 7/13</b>
<b>Cast-iron series 1LG4</b>						
<b>1500/3000, 4-/2-pole</b>	<b>180 M ... 315 L</b>	4.8 ... 170	1465 ... 2976	31 ... 546	9.1 ... 280	<b>7/14 ... 7/15</b>
<b>1000/1500, 6-/4-pole</b>	<b>180 M ... 315 L</b>	5.5 ... 170	960 ... 1490	55 ... 1092	12 ... 310	<b>7/16 ... 7/17</b>
<b>750/1500, 8-/4-pole</b>	<b>180 M ... 315 L</b>	4.5 ... 175	725 ... 1490	59 ... 1125	12.6 ... 315	<b>7/18 ... 7/19</b>

Forced-air cooled motors without external fan and fan cover with improved efficiency

Speed	Frame size	Rated output	Rated speed	Rated torque	Rated current at 400 V	Detailed selection and ordering data Page
rpm		kW	rpm	Nm	A	
<b>Aluminum series 1PP7 and 1PP5</b>						
<b>3000, 2-pole</b>	<b>63 M ... 200 L</b>	0.18 ... 37	2820 ... 2945	0.61 ... 120	0.5 ... 65	<b>7/20</b>
<b>1500, 4-pole</b>	<b>63 M ... 200 L</b>	0.12 ... 30	1350 ... 1465	0.85 ... 196	0.42 ... 55	<b>7/21</b>
<b>1000, 6-pole</b>	<b>63 M ... 200 L</b>	0.09 ... 22	850 ... 975	1.0 ... 215	0.44 ... 5	<b>7/22</b>
<b>750, 8-pole</b>	<b>71 M ... 200 L</b>	0.09 ... 15	630 ... 725	1.4 ... 198	0.36 ... 31.5	<b>7/23</b>
<b>Cast-iron series 1PP4</b>						
<b>3000, 2-pole</b>	<b>180 M ... 315 L</b>	22 ... 200	2945 ... 2982	71 ... 641	40.5 ... 325	<b>7/24</b>
<b>1500, 4-pole</b>	<b>180 M ... 315 L</b>	18.5 ... 200	1465 ... 1486	121 ... 1285	35 ... 340	<b>7/25</b>
<b>1000, 6-pole</b>	<b>180 M ... 315 L</b>	15 ... 160	965 ... 988	148 ... 1276	29.5 ... 235	<b>7/26</b>
<b>750, 8-pole</b>	<b>180 M ... 315 L</b>	11 ... 132	725 ... 738	145 ... 1423	25 ... 205	<b>7/27</b>

Forced-air cooled motors without external fan and fan cover with increased output

Speed	Frame size	Rated output	Rated speed	Rated torque	Rated current at 400 V	Detailed selection and ordering data Page
rpm		kW	rpm	Nm	A	
<b>Cast-iron series 1PP4</b>						
<b>3000, 2-pole</b>	<b>180 M ... 280 M</b>	30 ... 110	2950 ... 2975	97 ... 353	54 ... 184	<b>7/28</b>
<b>1500, 4-pole</b>	<b>180 M ... 280 M</b>	30 ... 110	1465 ... 1488	196 ... 706	59 ... 198	<b>7/28</b>
<b>1000, 6-pole</b>	<b>180 M ... 315 L</b>	18.5 ... 160	970 ... 988	182 ... 1547	37.5 ... 285	<b>7/29</b>
<b>750, 8-pole</b>	<b>180 M ... 315 L</b>	15 ... 132	720 ... 738	199 ... 1708	34 ... 245	<b>7/29</b>

### Selection and ordering data (continued)

#### Forced-air cooled motors without external fan and fan cover with improved efficiency (Improved Efficiency EFF2)

Speed	Frame size	Rated output	Rated speed	Rated torque	Rated current at 400 V	Detailed selection and ordering data Page
rpm		kW	rpm	Nm	A	
<b>Aluminum series 1LE1 (Motors without external fan and fan cover)</b>						
<b>3000, 2-pole</b>	<b>100 L ... 160 L</b>	3 ... 18.5	2835 ... 2935	10 ... 60	6 ... 34	<b>1/38 ... 1/39</b>
<b>1500, 4-pole</b>	<b>100 L ... 160 L</b>	2.2 ... 15	1425 ... 1460	14.8 ... 98	4.85 ... 29.5	<b>1/38 ... 1/39</b>
<b>1000, 6-pole</b>	<b>100 L ... 160 L</b>	1.5 ... 11	930 ... 970	15.3 ... 110	3.95 ... 23.5	<b>1/38 ... 1/39</b>
<b>750, 8-pole</b>	<b>100 L ... 160 L</b>	0.75 ... 7.5	700 ... 720	10.4 ... 100	2.65 ... 18.6	<b>1/38 ... 1/39</b>

#### Forced-air cooled motors without external fan and fan cover with high efficiency (High Efficiency EFF1)

Speed	Frame size	Rated output	Rated speed	Rated torque	Rated current at 400 V	Detailed selection and ordering data Page
rpm		kW	rpm	Nm	A	
<b>Aluminum series 1LE1 (Motors without external fan and fan cover)</b>						
<b>3000, 2-pole</b>	<b>100 L ... 160 L</b>	3 ... 18.5	2905 ... 2955	9.9 ... 60	5.9 ... 33	<b>1/42 ... 1/43</b>
<b>1500, 4-pole</b>	<b>100 L ... 160 L</b>	2.2 ... 15	1455 ... 1475	14 ... 97	4.55 ... 27.5	<b>1/42 ... 1/43</b>
<b>1000, 6-pole</b>	<b>100 L ... 160 L</b>	1.5 ... 11	965 ... 975	15 ... 108	3.5 ... 22	<b>1/42 ... 1/43</b>
<b>750, 8-pole</b>	<b>100 L ... 160 L</b>	0.75 ... 7.5	720 ... 735	9.9 ... 98	2.75 ... 17.4	<b>1/42 ... 1/43</b>

### More information

For more information, please contact your local Siemens contact – see “Siemens Contacts Worldwide” in the Appendix.

# IEC Squirrel-Cage Motors

## Fan motors

Self-ventilated, in pole-changing version  
Aluminum series 1LA7/5

### Selection and ordering data

Rated output at 50 Hz,		Frame size	Rated speed at 50 Hz,		Rated torque at 50 Hz,		Efficiency at 50 Hz 4/4-load		Power factor at 50 Hz 4/4-load		Rated current at 400 V, 50 Hz		Order No.	Price	Weight motor
1500 rpm	3000 rpm		1500 rpm	3000 rpm	1500 rpm	3000 rpm	1500 rpm	3000 rpm	1500 rpm	3000 rpm	1500 rpm	3000 rpm			
$P_{rated}$ kW		FS	$n_{rated}$ rpm		$T_{rated}$ Nm		$\eta_{rated}$ %		$\cos\phi_{rated}$		$I_{rated}$ A				$m$ kg
<b>4/2-pole, 1500/3000 rpm at 50 Hz, temperature class 155 (F), IP55 degree of protection</b>															
<b>Double pole-changing for driving fans with a winding in a Dahlander circuit</b>															
0.15	0.7	80 M	1400	2745	1	2.4	67	63	0.83	0.91	0.39	1.76	<b>1LA7 080-0BAQQ</b>		10
0.25	0.95	80 M	1385	2780	1.7	3.3	67	64	0.88	0.89	0.61	2.4	<b>1LA7 083-0BAQQ</b>		11
0.33	1.4	90 S	1420	2835	2.2	4.8	75	70	0.84	0.83	0.76	3.5	<b>1LA7 090-0BAQQ</b>		13
0.5	2	90 L	1420	2835	3.4	6.8	77	70	0.87	0.86	1.08	4.8	<b>1LA7 096-0BAQQ</b>		16
0.65	2.5	100 L	1430	2865	4.4	8.4	73	75	0.89	0.89	1.44	5.4	<b>1LA7 106-0BAQQ</b>		21
0.8	3.1	100 L	1425	2860	5.4	10	79	77	0.86	0.83	1.7	7	<b>1LA7 107-0BAQQ</b>		24
1.1	4.4	112 M	1445	2885	7.3	15	77	74	0.83	0.8	2.5	10.7	<b>1LA7 113-0BAQQ</b>		31
1.45	5.9	132 S	1455	2920	9.5	19	83	80	0.84	0.83	3	12.8	<b>1LA7 130-0BAQQ</b>		41
2	8	132 M	1455	2930	13	26	85	86	0.85	0.84	4	16	<b>1LA7 133-0BAQQ</b>		50
2.9	11.5	160 M	1455	2930	19	37	85.5	85	0.86	0.89	5.7	22	<b>1LA7 163-0BAQQ</b>		74
4.3	17	160 L	1455	2930	28	55	86	86	0.86	0.92	8.4	31	<b>1LA7 166-0BAQQ</b>		92

### Order No. supplements

Motor type	Penultimate position: Voltage code				Final position: Type of construction code						
	50 Hz, direct online starting				Without flange	With flange			With standard flange		With special flange
	230 V	400 V	500 V	690 V	IM B3, IM B6/7/8, IM V6/5 without protective cover	IM B5, IM V1 without protective cover, IM V3 <sup>1)</sup>	IM V1 with protective cover <sup>1) 2)</sup>	IM B35	IM B14, IM V19, IM V18 without protective cover	IM B34	IM B14, IM V19, IM V18 without protective cover
	1	6	5	0	0	1	4	6	2	7	3
<b>1LA7 08</b> .- . . . □□	○	○	○	○	□	✓	✓	✓	✓	✓	✓
<b>1LA7 09</b> .- . . . □□	○	○	○	○	□	✓	✓	✓	✓	✓	✓
<b>1LA7 10</b> .- . . . □□	○	○	○	○	□	✓	✓	✓	✓	✓	✓
<b>1LA7 11</b> .- . . . □□	○	○	○	○	□	✓	✓	✓	✓	✓	✓
<b>1LA7 13</b> .- . . . □□	○	○	○	○	□	✓	✓	✓	✓	✓	✓
<b>1LA7 16</b> .- . . . □□	○	○	○	○	□	✓	✓	✓	✓	✓	✓

- Standard version
- Without additional charge
- ✓ With additional charge
- Not possible

Order other voltages with voltage code **9** in the penultimate position and the corresponding order code (see "Special versions" in the "Selection and ordering data" under "Voltages").

Order other types of construction with type of construction code **9** in the final position and the corresponding order code (see "Special versions" in the "Selection and ordering data" under "Types of construction").

1) For type of construction IM V1 with/without protective cover, motors 1LA5 183-... to 1LA5 223-... (motor series 1LA5 frame sizes 180 M to 225 M) can be supplied with two additional eyebolts; specify order supplement **"Z"** and order code **K32**.

2) The "Second shaft extension" option, order code **K16** is not possible.

# IEC Squirrel-Cage Motors

## Fan motors

Self-ventilated, in pole-changing version  
Aluminum series 1LA7/5

### Selection and ordering data (continued)

Order No.	Locked-rotor torque with direct starting 1500 rpm $T_{LR}/T_{rated}$	Locked-rotor torque as multiple torque 3000 rpm $T_{LR}/T_{rated}$	Locked-rotor current of rated current 1500 rpm $I_{LR}/I_{rated}$	Locked-rotor current 3000 rpm $I_{LR}/I_{rated}$	Breakdown torque 1500 rpm $T_B/T_{rated}$	Breakdown torque 3000 rpm $T_B/T_{rated}$	Torque class CL	Moment of inertia $J$ kgm <sup>2</sup>	Mechanical limit speed at maximum supply frequency $n_{max}$ rpm
<b>4/2-pole, 1500/3000 rpm at 50 Hz, temperature class 155 (F), IP55 degree of protection</b>									
<b>Double pole-changing for driving fans with a winding in a Dahlander circuit</b>									
<b>1LA7 080-0BA□□</b>	1.8	1.6	3.8	4	2	2	10	0.0014	4200
<b>1LA7 083-0BA□□</b>	1.8	1.9	3.8	4.2	2	2	10	0.0017	4200
<b>1LA7 090-0BA□□</b>	1.9	1.8	4.5	4.3	2.1	2	10	0.0024	4200
<b>1LA7 096-0BA□□</b>	2.2	2.2	5.1	5	2.5	2.5	10	0.0033	4200
<b>1LA7 106-0BA□□</b>	1.7	2.2	5	5.5	2.3	2.3	10	0.0048	4200
<b>1LA7 107-0BA□□</b>	1.8	2.3	5.7	6.1	2.6	2.6	10	0.0055	4200
<b>1LA7 113-0BA□□</b>	2.1	2.2	6.2	6.2	2.4	2.4	10	0.011	4200
<b>1LA7 130-0BA□□</b>	2	2.1	6.8	6.5	2.8	2.8	10	0.018	4200
<b>1LA7 133-0BA□□</b>	1.9	2.1	7.6	7.5	2.6	2.6	10	0.023	4200
<b>1LA7 163-0BA□□</b>	1.8	1.8	6.9	7.4	2.5	2.4	10	0.043	4200
<b>1LA7 166-0BA□□</b>	1.9	2.2	7.1	8.5	2.5	2.6	10	0.06	4200

# IEC Squirrel-Cage Motors

## Fan motors

Self-ventilated, in pole-changing version  
Aluminum series 1LA7/5

### Selection and ordering data (continued)

Rated output at 50 Hz,		Frame size	Rated speed at 50 Hz,		Rated torque at 50 Hz,		Efficiency at 50 Hz 4/4-load		Power factor at 50 Hz 4/4-load		Rated current at 400 V, 50 Hz		Order No.	Price	Weight motor
1000 rpm	1500 rpm	FS	1000 rpm	1500 rpm	1000 rpm	1500 rpm	1000 rpm	1500 rpm	1000 rpm	1500 rpm	1000 rpm	1500 rpm			
$P_{rated}$ kW	$P_{rated}$ kW		$n_{rated}$ rpm	$n_{rated}$ rpm	$T_{rated}$ Nm	$T_{rated}$ Nm	$\eta_{rated}$ %	$\eta_{rated}$ %	$\cos\phi_{rated}$	$\cos\phi_{rated}$	$I_{rated}$ A	$I_{rated}$ A			$m$ kg
<b>6/4-pole, 1000/1500 rpm at 50 Hz, temperature class 155 (F), IP55 degree of protection</b>															
<b>Double pole-changing for driving fans with two windings</b>															
0.12	0.4	80 M	940	1430	1.2	2.7	45	55	0.75	0.76	0.51	1.38	<b>1LA7 080-1BDQ□</b>		9
0.18	0.55	80 M	930	1420	1.9	3.7	49	66	0.72	0.74	0.73	1.62	<b>1LA7 083-1BDQ□</b>		10
0.29	0.8	90 S	950	1430	2.9	5.3	55	68	0.71	0.81	1.07	2.1	<b>1LA7 090-1BDQ□</b>		13
0.38	1.1	90 L	950	1430	3.8	7.3	58	74	0.71	0.81	1.33	2.65	<b>1LA7 096-1BDQ□</b>		16
0.6	1.7	100 L	950	1410	6	11	67	75	0.74	0.86	1.75	3.8	<b>1LA7 106-1BDQ□</b>		21
0.75	2.1	100 L	950	1420	7.5	14	63	78	0.75	0.86	2.3	4.55	<b>1LA7 107-1BDQ□</b>		24
0.9	3	112 M	980	1450	8.8	20	71	81	0.61	0.8	3	6.7	<b>1LA7 113-1BDQ□</b>		31
1.2	3.9	132 S	975	1460	12	26	72	81	0.69	0.83	3.5	8.4	<b>1LA7 130-1BDQ□</b>		41
1.7	5.4	132 M	975	1460	17	35	75	82.5	0.72	0.83	4.55	11.4	<b>1LA7 133-1BDQ□</b>		49
2.5	7.2	160 M	980	1470	24	47	78	86	0.72	0.84	6.4	14.4	<b>1LA7 163-1BDQ□</b>		74
3.7	12	160 L	980	1470	36	78	77	89.5	0.75	0.83	9.3	23.3	<b>1LA7 166-1BDQ□</b>		92
5.5	16	180 M	965	1470	54	104	84	90.5	0.8	0.81	11.8	31.5	<b>1LA5 183-1BDQ□</b>		114
6.5	19	180 L	965	1460	64	124	84	88.5	0.81	0.85	13.8	36.5	<b>1LA5 186-1BDQ□</b>		128
9.5	26	200 L	980	1470	93	170	87	92.3	0.79	0.83	20	49	<b>1LA5 207-1BDQ□</b>		157

### Order No. supplements

Motor type	Penultimate position: Voltage code				Final position: Type of construction code				With standard flange		With special flange
	50 Hz, direct online starting				Without flange	With flange			IM B14, IM V19, IM V18 without protective cover	IM B34	IM B14, IM V19, IM V18 without protective cover
	230 V	400 V	500 V	690 V	IM B3, IM B6/7/8, IM V6/5 without protective cover	IM B5, IM V1 without protective cover, IM V3 <sup>1)</sup>	IM V1 with protective cover <sup>1) 2)</sup>	IM B35			
	<b>1</b>	<b>6</b>	<b>5</b>	<b>0</b>	<b>0</b>	<b>1</b>	<b>4</b>	<b>6</b>	<b>2</b>	<b>7</b>	<b>3</b>
<b>1LA7 08</b> . . . . □□	○	○	○	○	□	✓	✓	✓	✓	✓	✓
<b>1LA7 09</b> . . . . □□	○	○	○	○	□	✓	✓	✓	✓	✓	✓
<b>1LA7 10</b> . . . . □□	○	○	○	○	□	✓	✓	✓	✓	✓	✓
<b>1LA7 11</b> . . . . □□	○	○	○	○	□	✓	✓	✓	✓	✓	✓
<b>1LA7 13</b> . . . . □□	○	○	○	○	□	✓	✓	✓	✓	✓	✓
<b>1LA7 16</b> . . . . □□	○	○	○	○	□	✓	✓	✓	✓	✓	✓
<b>1LA5 18</b> . . . . □□	○	○	○	○	□	✓ <sup>3)</sup>	✓	✓	–	–	–
<b>1LA5 20</b> . . . . □□	○	○	○	○	□	✓ <sup>3)</sup>	✓	✓	–	–	–

- Standard version
- Without additional charge
- ✓ With additional charge
- Not possible

Order other voltages with voltage code **9** in the penultimate position and the corresponding order code (see "Special versions" in the "Selection and ordering data" under "Voltages").

Order other types of construction with type of construction code **9** in the final position and the corresponding order code (see "Special versions" in the "Selection and ordering data" under "Types of construction").

<sup>1)</sup> For type of construction IM V1 with/without protective cover, motors 1LA5 183-... to 1LA5 223-... (motor series 1LA5 frame sizes 180 M to 225 M) can be supplied with two additional eyebolts; specify order supplement "**Z**" and order code **K32**.

<sup>2)</sup> The "Second shaft extension" option, order code **K16** is not possible.

<sup>3)</sup> Type of construction IM V3 is only possible using type of construction code **9** and order code **M1G**.



# IEC Squirrel-Cage Motors

## Fan motors

Self-ventilated, in pole-changing version  
Aluminum series 1LA7/5

### Selection and ordering data (continued)

Order No.	Locked-rotor torque with direct starting 1000 rpm $T_{LR}/T_{rated}$	Locked-rotor torque as multiple torque 1500 rpm $T_{LR}/T_{rated}$	Locked-rotor current of rated current 1000 rpm $I_{LR}/I_{rated}$	Locked-rotor current 1500 rpm $I_{LR}/I_{rated}$	Breakdown torque 1000 rpm $T_B/T_{rated}$	Breakdown torque 1500 rpm $T_B/T_{rated}$	Torque class CL	Moment of inertia $J$ kgm <sup>2</sup>	Mechanical limit speed at maximum supply frequency $n_{max}$ rpm
<b>6/4-pole, 1000/1500 rpm at 50 Hz, temperature class 155 (F), IP55 degree of protection</b>									
<b>Double pole-changing for driving fans with two windings</b>									
<b>1LA7 080-1BD□□</b>	1.7	1.7	2.8	4	1.8	2	10	0.0014	4200
<b>1LA7 083-1BD□□</b>	1.5	1.7	2.5	4	1.8	2	10	0.0017	4200
<b>1LA7 090-1BD□□</b>	1.5	1.5	3.4	4.3	2	2	10	0.0027	4200
<b>1LA7 096-1BD□□</b>	1.8	1.8	3.8	4.9	2.3	2.3	10	0.0033	4200
<b>1LA7 106-1BD□□</b>	1.8	1.8	4.2	5.2	2.2	2.2	10	0.0049	4200
<b>1LA7 107-1BD□□</b>	1.6	1.9	3.9	5.2	2	2.2	10	0.0057	4200
<b>1LA7 113-1BD□□</b>	2	2.1	4.5	6.1	2.5	2.5	10	0.012	4200
<b>1LA7 130-1BD□□</b>	1.9	1.7	5.1	6.1	2.5	2.2	10	0.018	4200
<b>1LA7 133-1BD□□</b>	2.1	1.9	5.1	6.6	2.6	2.5	10	0.023	4200
<b>1LA7 163-1BD□□</b>	1.9	2	5.6	7.3	1.9	2	10	0.043	4200
<b>1LA7 166-1BD□□</b>	1.9	2.4	5.7	8.1	2.3	3	10	0.06	4200
<b>1LA5 183-1BD□□</b>	1.8	1.9	4.3	5.9	1.9	2.6	10	0.081	4200
<b>1LA5 186-1BD□□</b>	1.8	1.9	4.3	5.6	2.1	2.6	10	0.094	4200
<b>1LA5 207-1BD□□</b>	1.9	1.5	5.3	5.5	2.1	2.1	10	0.16	4200

# IEC Squirrel-Cage Motors

## Fan motors

Self-ventilated, in pole-changing version  
Aluminum series 1LA7/5

### Selection and ordering data (continued)

Rated output at 50 Hz,		Frame size	Rated speed at 50 Hz,		Rated torque at 50 Hz,		Efficiency at 50 Hz 4/4-load		Power factor at 50 Hz 4/4-load		Rated current at 400 V, 50 Hz		Order No.	Price	Weight motor
750 rpm	1500 rpm		750 rpm	1500 rpm	750 rpm	1500 rpm	750 rpm	1500 rpm	750 rpm	1500 rpm	750 rpm	1500 rpm			
$P_{\text{rated}}$	FS	$n_{\text{rated}}$	$T_{\text{rated}}$	$\eta_{\text{rated}}$	$\cos \phi_{\text{rated}}$	$I_{\text{rated}}$									<i>m</i>
kW	kW	rpm	rpm	Nm	Nm	%	%			A	A			kg	
<b>8/4-pole, 750/1500 rpm at 50 Hz, temperature class 155 (F), IP55 degree of protection</b>															
<b>Double pole-changing for driving fans with a winding in a Dahlander circuit</b>															
0.1	0.5	80 M	680	1375	1.4	3.5	42	69	0.61	0.82	0.57	1.28	<b>1LA7 080-0BBQQ</b>		9
0.15	0.7	80 M	685	1380	2.1	4.8	46	70	0.61	0.82	0.77	1.76	<b>1LA7 083-0BBQQ</b>		10
0.22	1	90 S	695	1370	3	7	41	70	0.62	0.86	1.25	2.4	<b>1LA7 090-0BBQQ</b>		13
0.33	1.5	90 L	700	1375	4.5	10	43	75	0.61	0.88	1.8	3.3	<b>1LA7 096-0BBQQ</b>		16
0.5	2	100 L	710	1415	6.7	13	51	79	0.57	0.85	2.5	4.3	<b>1LA7 106-0BBQQ</b>		21
0.65	2.5	100 L	700	1400	8.9	17	55	77	0.61	0.88	2.8	5.3	<b>1LA7 107-0BBQQ</b>		24
0.9	3.6	112 M	720	1440	12	24	55	78	0.5	0.83	4.7	11	<b>1LA7 113-0BBQQ</b>		31
1.1	4.7	132 S	720	1455	15	31	76	79	0.6	0.78	3.5	10.3	<b>1LA7 130-0BBQQ</b>		41
1.4	6.4	132 M	720	1455	19	42	77	83.5	0.6	0.83	4.4	13.3	<b>1LA7 133-0BBQQ</b>		49
2.2	9.5	160 M	725	1465	29	62	79	84	0.62	0.83	6.5	19.7	<b>1LA7 163-0BBQQ</b>		73
3.3	14	160 L	730	1470	43	91	85.5	88.5	0.6	0.8	9.3	28.6	<b>1LA7 166-0BBQQ</b>		91
4.5	16	180 M	730	1470	59	104	81	86	0.59	0.83	13.1	32.3	<b>1LA5 183-0BBQQ</b>		111
5	18.5	180 L	730	1470	65	120	80	88	0.6	0.83	15	36.5	<b>1LA5 186-0BBQQ</b>		118
7.5	28	200 L	732	1470	98	182	85	90.4	0.62	0.86	20.5	52	<b>1LA5 207-0BBQQ</b>		157

### Order No. supplements

Motor type	Penultimate position: Voltage code				Final position: Type of construction code				With standard flange		With special flange
	50 Hz, direct online starting				Without flange	With flange			IM B14, IM V19	IM B34	IM B14 IM V19
	230 V	400 V	500 V	690 V	IM B3, IM B6/7/8, IM V6/5 without protective cover	IM B5, IM V1 without protective cover, <sup>1)</sup> IM V3 <sup>1)</sup>	IM V1 with protective cover <sup>1) 2)</sup>	IM B35	IM V18 without protective cover	IM V18 without protective cover	IM V18 without protective cover
	1	6	5	0	0	1	4	6	2	7	3
<b>1LA7 08</b> . . . . . <b>QQ</b>	○	○	○	○	□	✓	✓	✓	✓	✓	✓
<b>1LA7 09</b> . . . . . <b>QQ</b>	○	○	○	○	□	✓	✓	✓	✓	✓	✓
<b>1LA7 10</b> . . . . . <b>QQ</b>	○	○	○	○	□	✓	✓	✓	✓	✓	✓
<b>1LA7 11</b> . . . . . <b>QQ</b>	○	○	○	○	□	✓	✓	✓	✓	✓	✓
<b>1LA7 13</b> . . . . . <b>QQ</b>	○	○	○	○	□	✓	✓	✓	✓	✓	✓
<b>1LA7 16</b> . . . . . <b>QQ</b>	○	○	○	○	□	✓	✓	✓	✓	✓	✓
<b>1LA5 18</b> . . . . . <b>QQ</b>	○	○	○	○	□	✓ <sup>3)</sup>	✓	✓	–	–	–
<b>1LA5 20</b> . . . . . <b>QQ</b>	○	○	○	○	□	✓ <sup>3)</sup>	✓	✓	–	–	–

- Standard version
- Without additional charge
- ✓ With additional charge
- Not possible

Order other voltages with voltage code **9** in the penultimate position and the corresponding order code (see "Special versions" in the "Selection and ordering data" under "Voltages").

Order other types of construction with type of construction code **9** in the final position and the corresponding order code (see "Special versions" in the "Selection and ordering data" under "Types of construction").

<sup>1)</sup> For type of construction IM V1 with/without protective cover, motors 1LA5 183-... to 1LA5 223-... (motor series 1LA5 frame sizes 180 M to 225 M) can be supplied with two additional eyebolts; specify order supplement "**Z**" and order code **K32**.

<sup>2)</sup> The "Second shaft extension" option, order code **K16** is not possible.

<sup>3)</sup> Type of construction IM V3 is only possible using type of construction code **9** and order code **M1G**.

# IEC Squirrel-Cage Motors

## Fan motors

Self-ventilated, in pole-changing version  
Aluminum series 1LA7/5

### Selection and ordering data (continued)

Order No.	Locked-rotor torque with direct starting 750 rpm $T_{LR}/T_{rated}$	Locked-rotor torque as multiple torque 1500 rpm $T_{LR}/T_{rated}$	Locked-rotor current of rated current 750 rpm $I_{LR}/I_{rated}$	Locked-rotor current 1500 rpm $I_{LR}/I_{rated}$	Breakdown torque 750 rpm $T_B/T_{rated}$	Breakdown torque 1500 rpm $T_B/T_{rated}$	Torque class CL	Moment of inertia $J$ kgm <sup>2</sup>	Mechanical limit speed at maximum supply frequency $n_{max}$ rpm
<b>8/4-pole, 750/1500 rpm at 50 Hz, temperature class 155 (F), IP55 degree of protection</b>									
<b>Double pole-changing for driving fans with a winding in a Dahlander circuit</b>									
<b>1LA7 080-0BB□□</b>	1.4	1.7	2.3	4.1	1.7	1.8	10	0.0014	4200
<b>1LA7 083-0BB□□</b>	1.4	1.8	2.4	4.2	1.7	1.8	10	0.0017	4200
<b>1LA7 090-0BB□□</b>	1.3	1.5	2.4	3.7	1.8	2	10	0.0024	4200
<b>1LA7 096-0BB□□</b>	1.5	1.8	2.6	4.2	1.8	2	10	0.0033	4200
<b>1LA7 106-0BB□□</b>	1.1	1.9	3.1	5.2	1.8	2.1	10	0.0047	4200
<b>1LA7 107-0BB□□</b>	1.1	1.9	3.1	5.4	1.8	2.1	10	0.0054	4200
<b>1LA7 113-0BB□□</b>	1.6	2.6	3.2	6.5	2.4	2.6	10	0.012	4200
<b>1LA7 130-0BB□□</b>	2	2.3	4.3	6.4	2.5	2.9	10	0.018	4200
<b>1LA7 133-0BB□□</b>	2.2	1.9	4.6	6.8	2.7	2.5	10	0.023	4200
<b>1LA7 163-0BB□□</b>	1.7	2	4.1	7	2	2.6	10	0.043	4200
<b>1LA7 166-0BB□□</b>	2	2.6	4.7	8.1	2.2	3.1	10	0.06	4200
<b>1LA5 183-0BB□□</b>	1.4	2.3	3.8	7	2.1	2.9	10	0.13	4200
<b>1LA5 186-0BB□□</b>	1.5	2.3	3.8	7	2.1	2.7	10	0.15	4200
<b>1LA5 207-0BB□□</b>	1.9	2.5	4.3	7.1	2.2	2.5	10	0.24	4200

# IEC Squirrel-Cage Motors

## Fan motors

Self-ventilated, in pole-changing version  
Aluminum series 1LA7/5

### Selection and ordering data (continued)

Rated output at 50 Hz			Frame size	Rated speed n <sub>rated</sub> at 50 Hz			Rated torque at 50 Hz			Efficiency at 50 Hz 4/4-load			Power factor at 50 Hz 4/4-load			Rated current I <sub>rated</sub> at 50 Hz			Order No.	Price	Weight motor
750 rpm	1000 rpm	1500 rpm	FS	750 rpm	1000 rpm	1500 rpm	750 rpm	1000 rpm	1500 rpm	750 rpm	1000 rpm	1500 rpm	750 rpm	1000 rpm	1500 rpm	750 rpm	1000 rpm	1500 rpm			m
P <sub>rated</sub> kW	kW	kW		n <sub>rated</sub> rpm	rpm	rpm	T <sub>rated</sub> Nm	Nm	Nm	η <sub>rated</sub> %	%	%	cos φ <sub>rated</sub> A	A	A	I <sub>rated</sub> A	A	A			kg
8/6/4-pole, 750/1000/1500 rpm at 50 Hz, temperature class 155 (F), IP55 degree of protection Triple pole-changing for driving fans with two windings, of which 750/1500 rpm in a Dahlander circuit																					
0.15	0.22	0.7	90 S	705	960	1430	2	2.3	4.7	48	56	70	0.63	0.69	0.83	0.72	0.82	1.74	<b>1LA7 090-1BJQQ</b>		12
0.22	0.3	0.95	90 L	705	955	1435	3	3	6.4	50	51	74	0.6	0.75	0.81	1.06	1.13	2.3	<b>1LA7 096-1BJQQ</b>		15
0.37	0.55	1.5	100 L	700	955	1400	5	5.5	10	51	63	76	0.63	0.74	0.88	1.66	1.71	3.25	<b>1LA7 106-1BJQQ</b>		20
0.45	0.7	1.8	100 L	700	970	1400	6.1	7	12	54	63	75	0.65	0.75	0.89	1.85	2.15	3.9	<b>1LA7 107-1BJQQ</b>		22
0.6	0.85	2.4	112 M	715	970	1445	8	8.4	16	53	66	79	0.59	0.66	0.86	2.75	2.8	5.1	<b>1LA7 113-1BJQQ</b>		29
0.75	1.1	3.1	132 S	730	980	1460	9.8	11	20	65	69	77	0.62	0.68	0.81	2.7	3.4	7.2	<b>1LA7 130-1BJQQ</b>		39
1	1.5	4.4	132 M	730	980	1460	13	15	29	68	71	79	0.6	0.68	0.83	3.55	4.5	9.7	<b>1LA7 133-1BJQQ</b>		46
1.6	2.2	6.6	160 M	730	980	1470	21	21	43	78	74	83	0.58	0.66	0.81	5.1	6.5	14.2	<b>1LA7 163-1BJQQ</b>		67
2.4	3.5	10	160 L	730	980	1470	31	34	65	79	78	85	0.58	0.69	0.82	7.6	9.4	20.7	<b>1LA7 166-1BJQQ</b>		85
3	4.5	13	180 M	730	980	1470	40	44	85	84.5	84	87.5	0.61	0.76	0.84	8.4	10.2	25.5	<b>1LA5 183-1BJQQ</b>		114
3.7	5.5	16	180 L	725	975	1465	49	54	104	83.5	86.5	87.5	0.62	0.76	0.85	10.3	12.1	31	<b>1LA5 186-1BJQQ</b>		128
5	8	22	200 L	730	975	1465	65	78	143	84	86	89	0.64	0.81	0.85	13.4	16.6	42	<b>1LA5 207-1BJQQ</b>		157

### Order No. supplements

Motor type	Penultimate position: Voltage code 50 Hz, direct online starting				Final position: Type of construction code			With standard flange		With special flange	
	230 V	400 V	500 V	690 V	Without flange	With flange		IM B14, IM V19 IM V18 without protective cover	IM B34		
	1	6	5	0	0	1	4	6	2	7	3
<b>1LA7 09</b> . . . . . □□	○	○	○	○	□	✓	✓	✓	✓	✓	✓
<b>1LA7 10</b> . . . . . □□	○	○	○	○	□	✓	✓	✓	✓	✓	✓
<b>1LA7 11</b> . . . . . □□	○	○	○	○	□	✓	✓	✓	✓	✓	✓
<b>1LA7 13</b> . . . . . □□	○	○	○	○	□	✓	✓	✓	✓	✓	✓
<b>1LA7 16</b> . . . . . □□	○	○	○	○	□	✓	✓	✓	✓	✓	✓
<b>1LA5 18</b> . . . . . □□	○	○	○	○	□	✓ <sup>3)</sup>	✓	✓	-	-	-
<b>1LA5 20</b> . . . . . □□	○	○	○	○	□	✓ <sup>3)</sup>	✓	✓	-	-	-

- Standard version
- Without additional charge
- ✓ With additional charge
- Not possible

Order other voltages with voltage code **9** in the penultimate position and the corresponding order code (see "Special versions" in the "Selection and ordering data" under "Voltages").

Order other types of construction with type of construction code **9** in the final position and the corresponding order code (see "Special versions" in the "Selection and ordering data" under "Types of construction").

<sup>1)</sup> For type of construction IM V1 with/without protective cover, motors 1LA5 183-... to 1LA5 223-... (motor series 1LA5 frame sizes 180 M to 225 M) can be supplied with two additional eyebolts; specify order supplement "**Z**" and order code **K32**.

<sup>2)</sup> The "Second shaft extension" option, order code **K16** is not possible.

<sup>3)</sup> Type of construction IM V3 is only possible using type of construction code **9** and order code **M1G**.

# IEC Squirrel-Cage Motors

## Fan motors

Self-ventilated, in pole-changing version  
Aluminum series 1LA7/5

### Selection and ordering data (continued)

Order No.	Locked-rotor torque	Locked-rotor torque	Locked-rotor torque	Locked-rotor current	Locked-rotor current	Locked-rotor current	Break-down torque	Break-down torque	Break-down torque	Torque class	Moment of inertia	Mechanical limit speed at maximum supply frequency
	with direct starting torque 750 rpm	starting as torque 1000 rpm	multiple of torque 1500 rpm	rated current 750 rpm	rated current 1000 rpm	rated current 1500 rpm	torque 750 rpm	torque 1000 rpm	torque 1500 rpm			
	$T_{LR}/T_{rated}$	$T_{LR}/T_{rated}$	$T_{LR}/T_{rated}$	$I_{LR}/I_{rated}$	$I_{LR}/I_{rated}$	$I_{LR}/I_{rated}$	$T_B/T_{rated}$	$T_B/T_{rated}$	$T_B/T_{rated}$	CL	J kgm <sup>2</sup>	$n_{max}$ rpm
<b>8/6/4-pole, 750/1000/1500 rpm at 50 Hz, temperature class 155 (F), IP55 degree of protection</b>												
<b>Triple pole-changing for driving fans with two windings, of which 750/1500 rpm in a Dahlander circuit</b>												
<b>1LA7 090-1BJQQ</b>	1.3	1.3	1.3	2.5	2.9	4.3	1.9	1.9	1.9	10	0.0028	4200
<b>1LA7 096-1BJQQ</b>	1.4	1.2	1.4	2.5	3.1	4.6	2.1	1.9	2.2	10	0.0035	4200
<b>1LA7 106-1BJQQ</b>	0.9	1.2	1.5	2.8	3.8	4.7	1.9	1.9	2.1	7	0.0048	4200
<b>1LA7 107-1BJQQ</b>	0.9	1.2	1.7	2.8	3.8	4.7	1.9	2	2.1	7	0.0058	4200
<b>1LA7 113-1BJQQ</b>	1.1	1.3	1.9	3.1	4.4	6	2.1	2.3	2.5	7	0.011	4200
<b>1LA7 130-1BJQQ</b>	1.7	1.7	1.5	3.7	4.5	5.5	2.3	2.3	2.5	10	0.018	4200
<b>1LA7 133-1BJQQ</b>	1.8	1.9	1.6	3.9	4.9	5.8	2.4	2.4	2.5	10	0.024	4200
<b>1LA7 163-1BJQQ</b>	1.4	1.7	1.7	3.9	5.1	7	2.1	2.4	2.7	7	0.04	4200
<b>1LA7 166-1BJQQ</b>	1.6	1.8	2	4.1	5.3	7.7	2.2	2.3	3	7	0.054	4200
<b>1LA5 183-1BJQQ</b>	1.2	1.8	1.3	3.9	5	5.4	1.6	2.2	2.3	7	0.081	4200
<b>1LA5 186-1BJQQ</b>	1.1	1.9	1.3	3.9	5	5.4	1.6	2.2	2.3	7	0.094	4200
<b>1LA5 207-1BJQQ</b>	1.2	1.9	1.3	3.6	5	5.4	1.8	2.2	2.6	7	0.16	4200



# IEC Squirrel-Cage Motors

## Fan motors

Self-ventilated, pole-changing version  
Cast-iron series 1LG4

### Selection and ordering data (continued)

Order No.	Locked-rotor torque	Locked-rotor torque	Locked-rotor current	Locked-rotor current	Break-down torque	Break-down torque	Torque class	Moment of inertia	Mechanical limit speed at maximum supply frequency
	with direct starting as multiple torque 1500 rpm	with direct starting as multiple torque 3000 rpm	of rated current 1500 rpm	of rated current 3000 rpm	torque 1500 rpm	torque 3000 rpm			
	$T_{LR}/T_{rated}$	$T_{LR}/T_{rated}$	$I_{rated}/I_{rated}$	$I_{rated}/I_{rated}$	$T_B/T_{rated}$	$T_B/T_{rated}$	CL	$J$ kgm <sup>2</sup>	$n_{max.}$ rpm
<b>4/2-pole, 1500/3000 rpm at 50 Hz, temperature class 155 (F), IP55 degree of protection</b>									
<b>Double pole-changing for driving fans with a winding in a Dahlander circuit</b>									
<b>1LG4 183-0BA□□</b>	2.3	2.5	7.5	8.1	2.8	3.0	10	0.12	4600
<b>1LG4 186-0BA□□</b>	2.0	2.3	6.8	7.7	2.8	3.3	10	0.14	4600
<b>1LG4 207-0BA□□</b>	2.5	2.8	7.6	8.7	3.1	3.5	10	0.23	4500
<b>1LG4 220-0BA□□</b>	2.3	2.4	6.7	7.5	2.8	3.1	10	0.40	4500
<b>1LG4 223-0BA□□</b>	2.2	2.5	6.2	8.1	2.6	3.5	10	0.49	4500
<b>1LG4 253-0BA□□</b>	2.2	2.3	6.2	6.6	2.0	3.0	10	0.69	3900
<b>1LG4 280-0BA□□</b>	2.5	2.3	7.0	7.6	2.8	3.3	10	1.20	3600
<b>1LG4 283-0BA□□</b>	2.2	2.1	6.1	7.5	2.4	2.9	10	1.40	3600
<b>1LG4 310-0BA□□</b>	2.4	1.9	8.4	8.1	2.9	3.3	10	1.90	3600
<b>1LG4 313-0BA□□</b>	2.3	1.7	7.6	6.7	2.9	2.9	10	2.30	3600
<b>1LG4 316-0BA□□</b>	2.2	1.8	7.6	7.1	2.6	2.6	10	2.90	3600 <sup>1)</sup>
<b>1LG4 317-0BA□□</b>	2.2	1.9	7.5	7.4	2.7	2.8	10	3.50	3600 <sup>1)</sup>

<sup>1)</sup> This is only valid for horizontal installation – reduction to 3000 rpm with vertical installation





# IEC Squirrel-Cage Motors

## Fan motors

Self-ventilated, pole-changing version  
Cast-iron series 1LG4

### Selection and ordering data (continued)

Order No.	Locked-rotor torque with direct starting 1000 rpm $T_{LR}/T_{rated}$	Locked-rotor torque as multiple torque 1500 rpm $T_{LR}/T_{rated}$	Locked-rotor current of rated current 1000 rpm $I_{LR}/I_{rated}$	Locked-rotor current 1500 rpm $I_{LR}/I_{rated}$	Breakdown torque 1000 rpm $T_B/T_{rated}$	Breakdown torque 1500 rpm $T_B/T_{rated}$	Torque class CL	Moment of inertia $J$ kgm <sup>2</sup>	Mechanical limit speed at maximum supply frequency $n_{max}$ rpm
<b>6/4-pole, 1000/1500 rpm at 50 Hz, temperature class 155 (F), IP55 degree of protection</b>									
<b>Double pole-changing for driving fans with two windings</b>									
<b>1LG4 183-1BD□□</b>	1.6	1.7	4	5.3	1.8	2.5	10	0.08	4200
<b>1LG4 186-1BD□□</b>	1.6	1.7	4	5.2	1.8	2.4	10	0.08	4200
<b>1LG4 207-1BD□□</b>	1.9	1.7	5	5.1	2.2	2.4	10	0.15	4200
<b>1LG4 220-1BD□□</b>	2.3	1.7	5.7	5.6	2.1	2.3	10	0.29	4500
<b>1LG4 223-1BD□□</b>	2.2	1.9	5.6	5.8	2.1	2.3	10	0.37	4500
<b>1LG4 253-1BD□□</b>	2	2	4.9	5.9	2	2.7	10	0.44	3700
<b>1LG4 280-1BD□□</b>	2.1	2.2	5	6.2	1.9	2.6	10	1.19	3000
<b>1LG4 283-1BD□□</b>	2.5	2.4	5.5	6.6	2.2	2.8	10	1.39	3000
<b>1LG4 310-1BD□□</b>	2.5	2.4	5.9	6.7	2.5	2.9	10	1.90	2600
<b>1LG4 313-1BD□□</b>	2.4	2.3	5.4	6.4	2.3	2.8	10	2.30	2600
<b>1LG4 316-1BD□□</b>	2.4	2.0	5.2	5.9	2.1	2.3	10	2.50	2600
<b>1LG4 317-1BD□□</b>	2.3	2.7	5.6	7.9	2.1	3.1	10	3.50	2600

# IEC Squirrel-Cage Motors

## Fan motors

### Self-ventilated, pole-changing version Cast-iron series 1LG4

#### Selection and ordering data (continued)

Rated output at 50 Hz,		Frame size	Rated speed at 50 Hz,		Rated torque at 50 Hz,		Efficiency at 50 Hz 4/4-load		Power factor at 50 Hz 4/4-load		Rated current at 400 V, 50 Hz		Order No.	Price	Weight motor
750 rpm	1500 rpm		750 rpm	1500 rpm	750 rpm	1500 rpm	750 rpm	1500 rpm	750 rpm	1500 rpm	750 rpm	1500 rpm			
$P_{rated}$		FS	$n_{rated}$		$T_{rated}$		$\eta_{rated}$		$\cos \phi_{rated}$		$I_{rated}$				$m$
kW	kW		rpm	rpm	Nm	Nm	%	%			A	A			kg
<b>8/4-pole, 750/1500 rpm at 50 Hz, temperature class 155 (F), IP55 degree of protection</b>															
<b>Double pole-changing for driving fans with a winding in a Dahlander circuit</b>															
4.5	16	180 M	725	1465	59	104	81.6	88.6	0.63	0.84	12.6	31	<b>1LG4 183-0BB□□</b>		155
5	18.5	180 L	725	1470	66	120	82.5	91	0.62	0.85	14.2	35	<b>1LG4 186-0BB□□</b>		180
7.5	28	200 L	730	1465	98	183	84.7	91	0.6	0.86	21.5	52	<b>1LG4 207-0BB□□</b>		220
9.5	35	225 S	738	1478	123	226	86	92	0.61	0.86	26	64	<b>1LG4 220-0BB□□</b>		295
11.5	42	225 M	738	1475	149	272	87.8	92.7	0.62	0.87	30.5	75	<b>1LG4 223-0BB□□</b>		330
14.5	52	250 M	740	1480	187	335	88.3	93.2	0.62	0.86	38	94	<b>1LG4 253-0BB□□</b>		430
19	70	280 S	740	1480	245	451	90.7	94	0.62	0.86	49	124	<b>1LG4 280-0BB□□</b>		530
23	83	280 M	740	1485	296	534	91	94.2	0.63	0.87	58	146	<b>1LG4 283-0BB□□</b>		665
26	95	315 S	742	1484	334	610	91.5	94.2	0.62	0.85	66	172	<b>1LG4 310-0BB□□</b>		730
30	115	315 M	744	1488	385	738	91.5	94.0	0.58	0.83	82	215	<b>1LG4 313-0BB□□</b>		810
35	140	315 L	744	1486	449	899	92.5	95.0	0.62	0.86	88	245	<b>1LG4 316-0BB□□</b>		960
45	175	315 L	744	1490	577	1125	92.5	95.0	0.57	0.84	124	315	<b>1LG4 317-0BB□□</b>		1090

#### Order No. supplements

Motor type	Penultimate position: Voltage code 50 Hz, direct online starting				Final position: Type of construction code							
	230 V	400 V	500 V	690 V	Without flange	With flange			With standard flange		With special flange	
					IM B3, IM B6/7/8, IM V6/5 without protective cover <sup>1)</sup>	IM B5, IM V1 without protective cover <sup>2)</sup>	IM V1 without protective cover <sup>2)</sup>	IM V1 with protective cover <sup>2)3)</sup>	IM B35	IM B14, IM V19 IM V18 without protective cover	IM B34	IM B14, IM V19 IM V18 without protective cover
	1	6	5	0	0	1	8	4	6	2	7	3
<b>1LG4 18</b> . . . . . □□	○	○	○	○	□	✓ <sup>4)</sup>	–	✓	✓	–	–	–
<b>1LG4 20</b> . . . . . □□	○	○	○	○	□	✓ <sup>4)</sup>	–	✓	✓	–	–	–
<b>1LG4 22</b> . . . . . □□	○	○	○	○	□	✓ <sup>4)</sup>	–	✓	✓	–	–	–
<b>1LG4 25</b> . . . . . □□	○	○	○	○	□	✓ <sup>4)</sup>	–	✓	✓	–	–	–
<b>1LG4 28</b> . . . . . □□	○	○	○	○	□	✓ <sup>4)</sup>	–	✓	✓	–	–	–
<b>1LG4 310</b> . . . . . □□	○	○	○	○	□	✓ <sup>4)</sup>	–	✓	✓	–	–	–
<b>1LG4 313</b> . . . . . □□	○	○	○	○	□	✓ <sup>4)</sup>	–	✓	✓	–	–	–
<b>1LG4 316</b> . . . . . □□	–	○	○	○	□ <sup>5)</sup>	–	✓	✓	✓	–	–	–
<b>1LG4 317</b> . . . . . □□	–	○	○	○	□ <sup>5)</sup>	–	✓	✓	✓	–	–	–

- Standard version
- Without additional charge
- ✓ With additional charge
- Not possible

Order other voltages with voltage code **9** in the penultimate position and the corresponding order code (see "Special versions" in the "Selection and ordering data" under "Voltages").

Order other types of construction with type of construction code **9** in the final position and the corresponding order code (see "Special versions" in the "Selection and ordering data" under "Types of construction").

- <sup>1)</sup> If motors 1LG4 183-... to 1LG4 318-... (motor series 1LG4 frame sizes 180 M to 315 L) in types of construction with feet IM B6, IM B7, IM V6 or IM V5 without protective cover are fixed to the wall, it is recommended that the motor feet are supported.
- <sup>2)</sup> Motors 1LG4 220-... to 1LG4 318-... (motor series 1LG4 frame sizes 225 S to 315 L) are supplied with two screw-in eyebolts in accordance with IM B5, whereby one can be relocated in accordance with IM V1 or IM V3. It is important to note that stress must not be applied perpendicular to the ring plane.

- <sup>3)</sup> The "Second shaft extension" option, order code **K16** is not possible.
- <sup>4)</sup> Type of construction IM V3 is only possible using type of construction code **9** and order code **M1G**.
- <sup>5)</sup> Type of construction IM V6/IM V5 without protective cover is only possible using type of construction code **9** and order code **M1E** and **M1D**.

# IEC Squirrel-Cage Motors

## Fan motors

Self-ventilated, pole-changing version  
Cast-iron series 1LG4

### Selection and ordering data (continued)

Order No.	Locked-rotor torque with direct starting at 750 rpm $T_{LR}/T_{rated}$	Locked-rotor torque as multiple of rated torque at 1500 rpm $T_{LR}/T_{rated}$	Locked-rotor current of rated current at 750 rpm $I_{LR}/I_{rated}$	Locked-rotor current at 1500 rpm $I_{LR}/I_{rated}$	Breakdown torque at 750 rpm $T_B/T_{rated}$	Breakdown torque at 1500 rpm $T_B/T_{rated}$	Torque class CL	Moment of inertia $J$ kgm <sup>2</sup>	Mechanical limit speed at maximum supply frequency $n_{max}$ rpm
<b>8/4-pole, 750/1500 rpm at 50 Hz, temperature class 155 (F), IP55 degree of protection</b>									
<b>Double pole-changing for driving fans with a winding in a Dahlander circuit</b>									
<b>1LG4 183-0BB□□</b>	1.4	2.2	3.6	6.8	2	3.1	10	0.11	4200
<b>1LG4 186-0BB□□</b>	1.6	2.4	3.7	7.2	2.1	3.3	10	0.14	4200
<b>1LG4 207-0BB□□</b>	2.1	2.7	4.3	7.3	2.5	2.9	10	0.19	4200
<b>1LG4 220-0BB□□</b>	2	1.7	4.4	6.9	2.3	2.9	10	0.44	4500
<b>1LG4 223-0BB□□</b>	1.9	2.4	4.5	6.9	2.2	3	10	0.48	4500
<b>1LG4 253-0BB□□</b>	2	2.5	4	6.8	1.8	2.6	10	0.85	3700
<b>1LG4 280-0BB□□</b>	1.8	2	4	6.3	1.8	2.5	10	1.19	3000
<b>1LG4 283-0BB□□</b>	1.9	2.2	4.2	7.2	1.8	2.7	10	1.71	3000
<b>1LG4 310-0BB□□</b>	1.9	2.3	4.6	6.5	1.9	2.6	10	1.90	2600
<b>1LG4 313-0BB□□</b>	2.1	2.5	5.0	7.4	2.1	2.7	10	2.30	2600
<b>1LG4 316-0BB□□</b>	2.0	2.4	4.7	7.0	2.1	2.6	10	2.90	2600
<b>1LG4 317-0BB□□</b>	2.1	3.1	4.7	7.5	2.2	3.0	10	4.20	2600

# IEC Squirrel-Cage Motors

## Fan motors

Forced-air cooled, without external fan and fan cover with improved efficiency – Aluminum series 1PP7/5

### Selection and ordering data

Rated output at 50 Hz	Frame size	Operating values at rated output						Locked-rotor torque with direct starting as multiple of rated torque	Locked-rotor current	Break-down torque	Torque class	Moment of inertia	Order No. For Order No. supplements for voltage and type of construction, see table below	Price	Weight
		Rated speed at 50 Hz	Rated torque at 50 Hz	Efficiency Class "Improved Efficiency" according to CEMEP	Efficiency at 50 Hz 4/4-load	Power factor at 50 Hz 4/4-load	Rated current at 50 Hz 400 V								
$P_{rated}$	FS	$n_{rated}$	$T_{rated}$	$\eta_{rated}$	$\cos\phi_{rated}$	$I_{rated}$	$T_{LR}/T_{rated}$	$I_{LR}/I_{rated}$	$T_B/T_{rated}$		$J$			Type of construction IM B3 approx. m	
kW		rpm	Nm	(EFF2) %		A					kg m <sup>2</sup>	► Phase-out model		kg	
<b>2-pole, 3000 rpm at 50 Hz, temperature class 155 (F), IP55 degree of protection</b>															
0.18	63 M	2820	0.61	63.0	0.82	0.50	2.0	3.7	2.2	16	0.00018	1PP7 060-2AA□□		4	
0.25	63 M	2830	0.84	65.0	0.82	0.68	2.0	4.0	2.2	16	0.00022	1PP7 063-2AA□□		4	
0.37	71 M	2740	1.3	66.0	0.82	1.00	2.3	3.5	2.3	16	0.00029	1PP7 070-2AA□□		5	
0.55	71 M	2800	1.9	71.0	0.82	1.36	2.5	4.3	2.6	16	0.00041	1PP7 073-2AA□□		6	
0.75	80 M	2855	2.5	73.0	0.86	1.73	2.3	5.6	2.4	16	0.00079	1PP7 080-2AA□□		9	
1.1	80 M	2845	3.7	EFF 2	77.0	0.87	2.40	2.6	6.1	16	0.0010	1PP7 083-2AA□□		11	
1.5	90 S	2860	5.0	EFF 2	79.0	0.85	3.25	2.4	5.5	16	0.0014	1PP7 090-2AA□□		13	
2.2	90 L	2880	7.3	EFF 2	82.0	0.85	4.55	2.8	6.3	16	0.0018	1PP7 096-2AA□□		16	
3	100 L	2890	9.9	EFF 2	84.0	0.85	6.10	2.8	6.8	16	0.0035	► 1PP7 106-2AA□□		22	
4	111 M	2905	13	EFF 2	86.0	0.86	7.80	2.6	7.2	16	0.0059	► 1PP7 113-2AA□□		29	
5.5	132 S	2925	18	EFF 2	86.5	0.89	10.4	2.0	5.9	16	0.015	► 1PP7 130-2AA□□		39	
7.5	132 S	2930	24	EFF 2	88.0	0.89	13.8	2.3	6.9	16	0.019	► 1PP7 131-2AA□□		48	
11	160 M	2940	36	EFF 2	89.5	0.88	20.0	2.1	6.5	16	0.034	► 1PP7 163-2AA□□		68	
15	160 M	2940	49	EFF 2	90.0	0.90	26.5	2.2	6.6	16	0.043	► 1PP7 164-2AA□□		77	
18.5	160 L	2940	60	EFF 2	91.0	0.91	32.0	2.4	7.0	16	0.051	► 1PP7 166-2AA□□		86	
22	180 M	2940	71	EFF 2	91.7	0.88	39.5 <sup>1)</sup>	2.5	6.9	16	0.077	1PP5 183-2AA□□		111	
30	200 L	2945	97	EFF 2	92.3	0.89	53	2.4	7.2	16	0.14	1PP5 206-2AA□□		159	
37	200 L	2945	120	EFF 2	92.8	0.89	65.0 <sup>1)</sup>	2.4	7.7	16	0.16	1PP5 207-2AA□□		179	

### Order No. supplements

Motor type	Penultimate position: Voltage code				Final position: Type of construction code						
	50 Hz				Without flange	With flange		With standard flange		With special flange	
	230 VΔ/400 VY	400 VΔ/690 VY	500 VY	500 VΔ	IM B3/6/7/8, IM V6/5 without protective cover	IM B5, IM V3 <sup>2)</sup>	IM V1 without protective cover <sup>2)3)</sup>	IM B35	IM B14, IM V19, IM V18 without protective cover	IM B34	IM B14, IM V19, IM V18 without protective cover
	1	6	3	5	0	1	1	6	2	7	3
1PP7 06 . . . . □□	○	○	○	-	□	✓	✓	-	✓	-	✓
1PP7 07 . . . . □□	○	○	○	-	□	✓	✓	-	✓	-	✓
1PP7 08 . . . . □□	○	○	○	-	□	✓	✓	-	✓	-	✓
1PP7 09 . . . . □□	○	○	○	-	□	✓	✓	-	✓	-	✓
1PP7 10 . . . . □□	○	○	○	○	□	✓	✓	-	✓	-	✓
1PP7 11 . . . . □□	○	○	○	○	□	✓	✓	-	✓	-	✓
1PP7 13 . . . . □□	○	○	○	○	□	✓	✓	-	✓	-	✓
1PP7 16 . . . . □□	○	○	○	○	□	✓	✓	-	✓	-	✓
1PP5 18 . . . . □□	○	○	○	○	□	✓ <sup>4)</sup>	✓	-	-	-	-
1PP5 20 . . . . □□	○	○	○	○	□	✓ <sup>4)</sup>	✓	-	-	-	-

- Standard version
- Without additional charge
- ✓ With additional charge
- Not possible

► The Order No. for 1PP7 motors marked with this symbol are phase-out models. 1LE1 motors are the successors. For additional information see catalog part 1 "New Generation 1LE1/1PC1" under "Forced-air cooled motors without external fan and fan cover" Pages 1/38 to 1/45.

Order other voltages with voltage code **9** in the penultimate position and the corresponding order code (see "Special versions" in the "Selection and ordering data" under "Voltages").

Order other types of construction with type of construction code **9** in the final position and the corresponding order code (see "Special versions" in the "Selection and ordering data" under "Types of construction").

<sup>1)</sup> For connection to 230 V, parallel feeders are necessary (see the "Technical information" section, "Connection, circuit and connection box" Page 0/38).  
<sup>2)</sup> Motors 1PP5 183-... to 1PP5 223-... (motor series 1PP5, frame size 180 M to 225 M) can be supplied with two additional eyebolts; specify supplement "Z" and order code **K32**.

<sup>3)</sup> The "Second shaft extension" option, order code **K16** is not possible.  
<sup>4)</sup> Type of construction IM V3 is only possible using type of construction code **9** and order code **M1G**.

# IEC Squirrel-Cage Motors

## Fan motors

Forced-air cooled, without external fan and fan cover  
with improved efficiency – Aluminum series 1PP7/5

### Selection and ordering data (continued)

Rated output at 50 Hz	Frame size	Operating values at rated output						Locked-rotor torque with direct starting as multiple of rated torque	Locked-rotor current	Break-down torque	Torque class	Moment of inertia	Order No. For Order No. supplements for voltage and type of construction, see table below	Price	Weight
		Rated speed at 50 Hz	Rated torque at 50 Hz	Efficiency Class "Improved Efficiency" according to CEMEP	Efficiency at 50 Hz 4/4-load	Power factor at 50 Hz 4/4-load	Rated current at 50 Hz 400 V								
$P_{rated}$	FS	$n_{rated}$	$T_{rated}$	$\eta_{rated}$	$\cos\phi_{rated}$	$I_{rated}$	$T_{LR}/T_{rated}$	$I_{LR}/I_{rated}$	$T_B/T_{rated}$		$J$			Type of construction IM B3 approx. m	
kW		rpm	Nm	EFF2 %		A				CL	kg m <sup>2</sup>	► Phase-out model		kg	
<b>4-pole, 1500 rpm at 50 Hz, temperature class 155 (F), IP55 degree of protection</b>															
0.12	63 M	1350	0.85	55.0	75	0.42	1.9	2.8	2.0	13	0.00029	<b>1PP7 060-4AB□□</b>		4	
0.18	63 M	1350	1.3	60.0	77	0.56	1.9	3.0	1.9	13	0.00037	<b>1PP7 063-4AB□□</b>		4	
0.25	71 M	1350	1.8	60.0	78	0.77	1.9	3.0	1.9	13	0.00052	<b>1PP7 070-4AB□□</b>		5	
0.37	71 M	1370	2.6	65.0	78	1.06	1.9	3.3	2.1	13	0.00077	<b>1PP7 073-4AB□□</b>		6	
0.55	80 M	1395	3.8	67.0	82	1.44	2.2	3.9	2.2	16	0.0014	<b>1PP7 080-4AA□□</b>		9	
0.75	80 M	1395	5.1	EFF 2 72.0	81	1.91	2.3	4.2	2.3	16	0.0017	<b>1PP7 083-4AA□□</b>		10	
1.1	90 S	1415	7.4	EFF 2 77.0	81	2.55	2.3	4.6	2.4	16	0.0024	<b>1PP7 090-4AA□□</b>		13	
1.5	90 L	1420	10	EFF 2 79.0	81	3.40	2.4	5.3	2.6	16	0.0033	<b>1PP7 096-4AA□□</b>		16	
2.2	100 L	1420	15	EFF 2 82.0	82	4.70	2.5	5.6	2.8	16	0.0047	► 1PP7 106-4AA□□		21	
3	100 L	1420	20	EFF 2 83.0	82	6.40	2.7	5.6	3.0	16	0.0055	► 1PP7 107-4AA□□		24	
4	112 M	1440	27	EFF 2 85.0	83	8.20	2.7	6.0	3.0	16	0.012	► 1PP7 113-4AA□□		31	
5.5	132 S	1455	36	EFF 2 86.0	81	11.4	2.5	6.3	3.1	16	0.018	► 1PP7 130-4AA□□		41	
7.5	132 M	1455	49	EFF 2 87.0	82	15.2	2.7	6.7	3.2	16	0.023	► 1PP7 133-4AA□□		49	
11	160 M	1460	72	EFF 2 88.5	84	21.5	2.2	6.2	2.7	16	0.043	► 1PP7 163-4AA□□		73	
15	160 L	1460	98	EFF 2 90.0	84	28.5	2.6	6.5	3.0	16	0.055	► 1PP7 166-4AA□□		85	
18.5	180 M	1460	121	EFF 2 90.5	83	35.5 <sup>1)</sup>	2.3	7.5	3.0	16	0.13	<b>1PP5 183-4AA□□</b>		108	
22	180 L	1460	144	EFF 2 91.2	84	41.5 <sup>1)</sup>	2.3	7.5	3.0	16	0.15	<b>1PP5 186-4AA□□</b>		118	
30	200 L	1465	196	EFF 2 91.8	86	55	2.6	7.0	3.2	16	0.24	<b>1PP5 207-4AA□□</b>		157	

### Order No. supplements

Motor type	Penultimate position: Voltage code				Final position: Type of construction code						
	50 Hz				Without flange	With flange		With standard flange			With special flange
	230 VΔ/400 VY	400 VΔ/690 VY	500 VY	500 VΔ	IM B3, IM B6/7/8, IM V6/5 without protective cover	IM B5, IM V3 <sup>2)</sup>	IM V1 without protective cover <sup>2) 3)</sup>	IM B35	IM B14, IM V19, IM V18 without protective cover	IM B34	IM B14, IM V19, IM V18 without protective cover
	1	6	3	5	0	1	1	6	2	7	3
<b>1PP7 06</b> . . . . . □□	○	○	○	–	□	✓	✓	–	✓	–	✓
<b>1PP7 07</b> . . . . . □□	○	○	○	–	□	✓	✓	–	✓	–	✓
<b>1PP7 08</b> . . . . . □□	○	○	○	–	□	✓	✓	–	✓	–	✓
<b>1PP7 09</b> . . . . . □□	○	○	○	–	□	✓	✓	–	✓	–	✓
1PP7 10 . . . . . □□	○	○	○	○	□	✓	✓	–	✓	–	✓
1PP7 11 . . . . . □□	○	○	○	○	□	✓	✓	–	✓	–	✓
1PP7 13 . . . . . □□	○	○	○	○	□	✓	✓	–	✓	–	✓
1PP7 16 . . . . . □□	○	○	○	○	□	✓	✓	–	✓	–	✓
<b>1PP5 18</b> . . . . . □□	○	○	○	○	□	✓ <sup>4)</sup>	✓	–	–	–	–
<b>1PP5 20</b> . . . . . □□	○	○	○	○	□	✓ <sup>4)</sup>	✓	–	–	–	–

- Standard version
- Without additional charge
- ✓ With additional charge
- Not possible

► The Order No. for 1PP7 motors marked with this symbol are phase-out models.  
1LE1 motors are the successors.  
For additional information see catalog part 1 "New Generation 1LE1/1PC1" under "Forced-air cooled motors without external fan and fan cover" Pages 1/38 to 1/45.

Order other voltages with voltage code **9** in the penultimate position and the corresponding order code (see "Special versions" in the "Selection and ordering data" under "Voltages").

Order other types of construction with type of construction code **9** in the final position and the corresponding order code (see "Special versions" in the "Selection and ordering data" under "Types of construction").

<sup>1)</sup> For connection to 230 V, parallel feeders are necessary (see the "Technical information" section, "Connection, circuit and connection box" Page 0/38).  
<sup>2)</sup> Motors 1PP5 183... to 1PP5 223... (motor series 1PP5, frame size 180 M to 225 M) can be supplied with two additional eyebolts; specify supplement "Z" and order code **K32**.

<sup>3)</sup> The "Second shaft extension" option, order code **K16** is not possible.  
<sup>4)</sup> Type of construction IM V3 is only possible using type of construction code **9** and order code **M1G**.

# IEC Squirrel-Cage Motors

## Fan motors

Forced-air cooled, without external fan and fan cover with improved efficiency – Aluminum series 1PP7/5

### Selection and ordering data (continued)

Rated output at 50 Hz	Frame size	Operating values at rated output					Locked-rotor torque with direct starting as multiple of rated torque	Locked-rotor current as multiple of rated current	Break-down torque	Torque class	Moment of inertia	Order No. For Order No. supplements for voltage and type of construction, see table below	Price	Weight
		Rated speed at 50 Hz	Rated torque at 50 Hz	Efficiency at 50 Hz 4/4-load	Power factor at 50 Hz 4/4-load	Rated current at 50 Hz 400 V								
$P_{rated}$ kW	FS	$n_{rated}$ rpm	$T_{rated}$ Nm	$\eta_{rated}$ %	$\cos\phi_{rated}$	$I_{rated}$ A	$T_{LR}/T_{rated}$	$I_{LR}/I_{rated}$	$T_B/T_{rated}$	CL	$J$ kg m <sup>2</sup>	► Phase-out model		
<b>6-pole, 1000 rpm at 50 Hz, temperature class 155 (F), IP55 degree of protection</b>														
0.09	63 M	850	1.0	45.0	0.66	0.44	1.8	2.0	1.9	13	0.00037	<b>1PP7 063-6AA□□</b>	4	
0.18	71 M	850	2.0	53.0	0.73	0.67	2.1	2.3	1.9	16	0.00055	<b>1PP7 070-6AA□□</b>	5	
0.25	71 M	860	2.8	60.0	0.76	0.79	2.2	2.7	2.0	16	0.00080	<b>1PP7 073-6AA□□</b>	6	
0.37	80 M	920	3.8	62.0	0.72	1.20	1.9	3.1	2.1	16	0.0014	<b>1PP7 080-6AA□□</b>	9	
0.55	80 M	910	5.8	67.0	0.74	1.60	2.1	3.4	2.2	16	0.0017	<b>1PP7 083-6AA□□</b>	10	
0.75	90 S	915	7.8	69.0	0.76	2.05	2.2	3.7	2.2	16	0.0024	<b>1PP7 090-6AA□□</b>	13	
1.1	90 L	915	11	72.0	0.77	2.85	2.3	3.8	2.3	16	0.0033	<b>1PP7 096-6AA□□</b>	16	
1.5	100 L	925	15	74.0	0.75	3.90	2.3	4.0	2.3	16	0.0047	► 1PP7 106-6AA□□	21	
2.2	112 M	940	22	78.0	0.78	5.20	2.2	4.6	2.5	16	0.0091	► 1PP7 113-6AA□□	26	
3	132 S	950	30	79.0	0.76	7.20	1.9	4.2	2.2	16	0.015	► 1PP7 130-6AA□□	38	
4	132 M	950	40	80.5	0.76	9.40	2.1	4.5	2.4	15	0.019	► 1PP7 133-6AA□□	44	
5.5	132 M	950	55	83.0	0.76	12.6	2.3	5.0	2.6	16	0.025	► 1PP7 134-6AA□□	52	
7.5	160 M	960	75	86.0	0.74	17.0	2.1	4.6	2.5	16	0.044	► 1PP7 163-6AA□□	74	
11	160 L	960	109	87.5	0.74	24.5	2.3	4.8	2.6	16	0.063	► 1PP7 166-6AA□□	95	
15	180 M	970	148	89.5	0.77	31.5	2.0	5.2	2.4	16	0.15	<b>1PP5 186-6AA□□</b>	124	
18.5	200 L	975	181	90.2	0.77	38.5	2.7	5.5	2.8	16	0.24	<b>1PP5 206-6AA□□</b>	161	
22	200 L	975	215	90.8	0.77	45.5	2.8	5.5	2.9	16	0.28	<b>1PP5 207-6AA□□</b>	183	

### Order No. supplements

Motor type	Penultimate position: Voltage code 50 Hz				Final position: Type of construction code							
	230 VΔ/400 VY	400 VΔ/690 VY	500 VY	500 VΔ	Without flange	With flange			With standard flange		With special flange	
					IM B3, IM B6/7/8, IM V6/5 without protective cover	IM B5, IM V3 <sup>1)</sup>	IM V1 without protective cover <sup>1) 2)</sup>	IM B35	IM B14, IM V19, IM V18 without protective cover	IM B34	IM B14, IM V19, IM V18 without protective cover	
	1	6	3	5	0	1	1	6	2	7	3	
<b>1PP7 06</b> . . . . □□	○	○	○	–	□	✓	✓	–	✓	–	✓	
<b>1PP7 07</b> . . . . □□	○	○	○	–	□	✓	✓	–	✓	–	✓	
<b>1PP7 08</b> . . . . □□	○	○	○	–	□	✓	✓	–	✓	–	✓	
<b>1PP7 09</b> . . . . □□	○	○	○	–	□	✓	✓	–	✓	–	✓	
1PP7 10 . . . . □□	○	○	○	○	□	✓	✓	–	✓	–	✓	
1PP7 11 . . . . □□	○	○	○	○	□	✓	✓	–	✓	–	✓	
1PP7 13 . . . . □□	○	○	○	○	□	✓	✓	–	✓	–	✓	
1PP7 16 . . . . □□	○	○	○	○	□	✓	✓	–	✓	–	✓	
<b>1PP5 18</b> . . . . □□	○	○	○	○	□	✓ <sup>3)</sup>	✓	–	–	–	–	
<b>1PP5 20</b> . . . . □□	○	○	○	○	□	✓ <sup>3)</sup>	✓	–	–	–	–	

- Standard version
- Without additional charge
- ✓ With additional charge
- Not possible

► The Order No. for 1PP7 motors marked with this symbol are phase-out models.  
1LE1 motors are the successors.  
For additional information see catalog part 1 "New Generation 1LE1/1PC1" under "Forced-air cooled motors without external fan and fan cover" Pages 1/38 to 1/45.

Order other voltages with voltage code **9** in the penultimate position and the corresponding order code (see "Special versions" in the "Selection and ordering data" under "Voltages").

Order other types of construction with type of construction code **9** in the final position and the corresponding order code (see "Special versions" in the "Selection and ordering data" under "Types of construction").

- 1) Motors 1PP5 183-... to 1PP5 223-... (motor series 1PP5, frame size 180 M to 225 M) can be supplied with two additional eyebolts; specify supplement "**Z**" and order code **K32**.
- 2) The "Second shaft extension" option, order code **K16** is not possible.
- 3) Type of construction IM V3 is only possible using type of construction code **9** and order code **M1G**.

# IEC Squirrel-Cage Motors

## Fan motors

Forced-air cooled, without external fan and fan cover  
with improved efficiency – Aluminum series 1PP7/5

### Selection and ordering data (continued)

Rated output at 50 Hz	Frame size	Operating values at rated output					Locked-rotor torque with direct starting as multiple of rated torque	Locked-rotor current of rated current	Break-down torque	Torque class	Moment of inertia	Order No. For Order No. supplements for voltage and type of construction, see table below	Price	Weight
		Rated speed at 50 Hz	Rated torque at 50 Hz	Efficiency at 50 Hz 4/4-load	Power factor at 50 Hz 4/4-load	Rated current at 50 Hz 400 V								
$P_{rated}$ kW	FS	$n_{rated}$ rpm	$T_{rated}$ Nm	$\eta_{rated}$ %	$\cos\phi_{rated}$	$I_{rated}$ A	$T_{LR}/T_{rated}$	$I_{LR}/I_{rated}$	$T_B/T_{rated}$	CL	$J$ kg m <sup>2</sup>	► Phase-out model	Type of construction IM B3 approx. m kg	
<b>8-pole, 750 rpm at 50 Hz, temperature class 155 (F), IP55 degree of protection</b>														
0.09	71 M	630	1.4	53.0	0.68	0.36	1.9	2.2	1.7	13	0.0008	<b>1PP7 070-8AB□□</b>	6	
0.12	71 M	645	1.8	53.0	0.64	0.51	2.2	2.2	2.0	13	0.0008	<b>1PP7 073-8AB□□</b>	6	
0.18	80 M	675	2.5	51.0	0.68	0.75	1.7	2.3	1.9	13	0.0014	<b>1PP7 080-8AB□□</b>	9	
0.25	80 M	685	3.5	55.0	0.64	1.02	2.0	2.6	2.2	13	0.0017	<b>1PP7 083-8AB□□</b>	10	
0.37	90 S	675	5.2	63.0	0.75	1.14	1.6	2.9	1.8	13	0.0023	<b>1PP7 090-8AB□□</b>	11	
0.55	90 L	675	7.8	66.0	0.76	1.58	1.7	3.0	1.9	13	0.0031	<b>1PP7 096-8AB□□</b>	13	
0.75	100 L	680	11	66.0	0.76	2.15	1.6	3.0	1.9	13	0.0051	► 1PP7 106-8AB□□	19	
1.1	100 L	680	15	72.0	0.76	2.90	1.8	3.3	2.1	13	0.0063	► 1PP7 107-8AB□□	22	
1.5	112 M	705	20	74.0	0.76	3.85	1.8	3.7	2.1	13	0.013	► 1PP7 113-8AB□□	24	
2.2	132 S	700	30	75.0	0.74	5.70	1.9	3.9	2.3	13	0.014	► 1PP7 130-8AB□□	38	
3	132 M	700	41	77.0	0.74	7.60	2.1	4.1	2.4	13	0.019	► 1PP7 133-8AB□□	44	
4	160 M	715	53	80.0	0.72	10.0	2.2	4.5	2.6	13	0.036	► 1PP7 163-8AB□□	64	
5.5	160 L	710	74	83.5	0.73	13.0	2.3	4.7	2.7	13	0.046	► 1PP7 164-8AB□□	74	
7.5	160 L	715	100	85.5	0.72	17.6	2.7	5.3	3.0	13	0.064	► 1PP7 166-8AB□□	94	
11	180 M	725	145	87.0	0.75	24.5	2.0	5.0	2.2	13	0.21	<b>1PP5 186-8AB□□</b>	126	
15	200 L	725	198	87.5	0.78	31.5	2.1	5.0	2.2	13	0.37	<b>1PP5 207-8AB□□</b>	176	

### Order No. supplements

Motor type	Penultimate position: Voltage code 50 Hz				Final position: Type of construction code							
	230 VΔ/400 VY	400 VΔ/690 VY	500 VY	500 VΔ	Without flange IM B3/6/7/8, IM V6/5 without protective cover	With flange IM B5, IM V3 <sup>1)</sup>	IM V1 without protective cover <sup>1) 2)</sup>	IM B35	With standard flange IM B14, IM V19 IM V18 without protective cover	IM B34	With special flange IM B14, IM V19 IM V18 without protective cover	
	1	6	3	5	0	1	1	6	2	7	3	
<b>1PP7 07</b> . . . . □□	○	○	○	–	□	✓	✓	–	✓	–	✓	
<b>1PP7 08</b> . . . . □□	○	○	○	–	□	✓	✓	–	✓	–	✓	
<b>1PP7 09</b> . . . . □□	○	○	○	–	□	✓	✓	–	✓	–	✓	
1PP7 10 . . . . □□	○	○	○	○	□	✓	✓	–	✓	–	✓	
1PP7 11 . . . . □□	○	○	○	○	□	✓	✓	–	✓	–	✓	
1PP7 13 . . . . □□	○	○	○	○	□	✓	✓	–	✓	–	✓	
1PP7 16 . . . . □□	○	○	○	○	□	✓	✓	–	✓	–	✓	
<b>1PP5 18</b> . . . . □□	○	○	○	○	□	✓ <sup>3)</sup>	✓	–	–	–	–	
<b>1PP5 20</b> . . . . □□	○	○	○	○	□	✓ <sup>3)</sup>	✓	–	–	–	–	

- Standard version
- Without additional charge
- ✓ With additional charge
- Not possible

► The Order No. for 1PP7 motors marked with this symbol are phase-out models.  
1LE1 motors are the successors.  
For additional information see catalog part 1 "New Generation 1LE1/1PC1" under "Forced-air cooled motors without external fan and fan cover" Pages 1/38 to 1/45.

Order other voltages with voltage code **9** in the penultimate position and the corresponding order code (see "Special versions" in the "Selection and ordering data" under "Voltages").

Order other types of construction with type of construction code **9** in the final position and the corresponding order code (see "Special versions" in the "Selection and ordering data" under "Types of construction").

- 1) Motors 1PP5 183-... to 1PP5 223-... (motor series 1PP5, frame size 180 M to 225 M) can be supplied with two additional eyebolts; specify supplement "Z" and order code **K32**.
- 2) The "Second shaft extension" option, order code **K16** is not possible.
- 3) Type of construction IM V3 is only possible using type of construction code **9** and order code **M1G**.

# IEC Squirrel-Cage Motors

## Fan motors

Forced-air cooled, without external fan and fan cover  
with improved efficiency – Cast-iron series 1PP4

### Selection and ordering data

Rated output at 50 Hz	Frame size	Operating values at rated output						Locked-rotor torque with direct starting as multiple of rated torque	Locked-rotor current as multiple of rated current	Break-down torque	Torque class	Moment of inertia	Order No. For Order No. supplements for voltage and type of construction, see table below	Price	Weight
		Rated speed at 50 Hz	Rated torque at 50 Hz	Efficiency Class "Improved Efficiency" according to CEMEP	Efficiency at 50 Hz 4/4-load	Power factor at 50 Hz 4/4-load	Rated current at 50 Hz 400 V								
$P_{rated}$	FS	$n_{rated}$	$T_{rated}$	$\eta_{rated}$	$\cos\phi_{rated}$	$I_{rated}$	$T_{LR}/T_{rated}$	$I_{LR}/I_{rated}$	$T_B/T_{rated}$		$J$			Type of construction IM B3 approx. m	
kW		rpm	Nm	EFF2 %		A					kg m <sup>2</sup>			kg	
<b>2-pole, 3000 rpm at 50 Hz, temperature class 155 (F), IP55 degree of protection</b>															
22	180 M	2945	71	EFF 2	92.1	0.86	40	2.5	6.4	3.4	16	0.068	<b>1PP4 183-2FA□□</b>	140	
30	200 L	2950	97	EFF 2	92.4	0.88	53	2.3	6.5	3.0	16	0.129	<b>1PP4 206-2FA□□</b>	195	
37	200 L	2955	120	EFF 2	93.4	0.89	64	2.5	7.2	3.3	16	0.153	<b>1PP4 207-2FA□□</b>	215	
45	225 M	2960	145	EFF 2	93.9	0.88	79	2.4	6.7	3.1	16	0.217	<b>1PP4 223-2FA□□</b>	275	
55	250 M	2970	177	EFF 2	94.1	0.88	96	2.1	6.7	3.1	13	0.403	<b>1PP4 253-2FB□□</b>	360	
75	280 S	2975	241	EFF 2	94.9	0.88	130	2.5	7.5	3.1	13	0.715	<b>1PP4 280-2FB□□</b>	480	
90	280 M	2975	289	EFF 2	95.4	0.89	152	2.6	7.2	3.1	13	0.832	<b>1PP4 283-2FB□□</b>	520	
110	315 S	2982	352		95.2	0.88	190	2.4	7.2	3.1	13	1.19	<b>1PP4 310-2FB□□</b>	700	
132	315 M	2982	423		95.6	0.90	220	2.4	6.9	3.0	13	1.39	<b>1PP4 313-2FB□□</b>	755	
160	315 L	2982	512		96.0	0.91	265	2.4	7.0	3.0	13	1.62	<b>1PP4 316-2FB□□</b>	880	
200	315 L	2982	641		96.3	0.92	325	2.3	6.7	2.9	13	2.09	<b>1PP4 317-2FB□□</b>	995	

### Order No. supplements

Motor type	Penultimate position: Voltage code				Final position: Type of construction code							
	50 Hz				Without flange	With flange			With standard flange		With special flange	
	230 VΔ/400 VY	400 VΔ/690 VY	500 VY	500 VΔ	IM B3/6/7/8, IM V6/5 without protective cover 1)	IM B5, IM V1 without protective cover 2)	IM V1 without protective cover 2)	IM B35	IM B14, IM V19, IM V18 without protective cover	IM B34	IM B14, IM V19, IM V18 without protective cover	
	1	6	3	5	0	1	8	6	2	7	3	
<b>1PP4 18</b> . . . . □□	○	○	○	○	□	✓	–	✓	–	–	–	
<b>1PP4 20</b> . . . . □□	○	○	○	○	□	✓	–	✓	–	–	–	
<b>1PP4 22</b> . . . . □□	○	○	○	○	□	✓	–	✓	–	–	–	
<b>1PP4 25</b> . . . . □□	○	○	○	○	□	✓	–	✓	–	–	–	
<b>1PP4 28</b> . . . . □□	○	○	○	○	□	✓	–	✓	–	–	–	
<b>1PP4 310</b> . . . . □□	○	○	○	○	□	✓	–	✓	–	–	–	
<b>1PP4 313</b> . . . . □□	○	○	○	○	□	✓	–	✓	–	–	–	
<b>1PP4 316</b> . . . . □□	–	○	–	○	□ <sup>3)</sup>	–	✓	✓	–	–	–	
<b>1PP4 317</b> . . . . □□	–	○	–	○	□ <sup>3)</sup>	–	✓	✓	–	–	–	

- Standard version
- Without additional charge
- ✓ With additional charge
- Not possible

Order other voltages with voltage code **9** in the penultimate position and the corresponding order code (see "Special versions" in the "Selection and ordering data" under "Voltages").

Order other types of construction with type of construction code **9** in the final position and the corresponding order code (see "Special versions" in the "Selection and ordering data" under "Types of construction").

1) If motors 1PP4 183-... to 1PP4 317-... (motor series 1PP4 frame sizes 180 M to 315 L) in types of construction with feet IM B6, IM B7, IM V6 or IM V5 without protective cover are fixed to the wall, it is recommended that the motor feet are supported.

2) Motors 1PP4 220-... to 1PP4 317-... (motor series 1PP4 frame sizes 225 S to 315 L) are supplied with two screw-in eyebolts in accordance with IM B5, whereby one can be relocated in accordance with IM V1 or IM V3. It is important to note that stress must not be applied perpendicular to the ring plane.

3) Type of construction IM V6 and IM V5 without protective cover is only possible using type of construction code **9** and order code **M1E** or **M1D**.



# IEC Squirrel-Cage Motors

## Fan motors

Forced-air cooled, without external fan and fan cover  
with improved efficiency – Cast-iron series 1PP4

### Selection and ordering data (continued)

Rated output at 50 Hz	Frame size	Operating values at rated output						Locked-rotor torque with direct starting as multiple of rated torque	Locked-rotor current	Break-down torque	Torque class	Moment of inertia	Order No. For Order No. supplements for voltage and type of construction, see table below	Price	Weight
		Rated speed at 50 Hz	Rated torque at 50 Hz	Efficiency Class "Improved Efficiency" according to CEMEP	Efficiency at 50 Hz 4/4-load	Power factor at 50 Hz 4/4-load	Rated current at 50 Hz 400 V								
$P_{rated}$	FS	$n_{rated}$	$T_{rated}$	$\eta_{rated}$	$\cos\phi_{rated}$	$I_{rated}$	$T_{LR}/T_{rated}$	$I_{LR}/I_{rated}$	$T_B/T_{rated}$		$J$			Type of construction IM B3 approx. $m$	
kW		rpm	Nm	EFF2 %		A					kg m <sup>2</sup>			kg	
<b>4-pole, 1500 rpm at 50 Hz, temperature class 155 (F), IP55 degree of protection</b>															
18.5	180 M	1465	121	EFF 2	90.8	0.84	35	2.4	6.7	3.1	16	0.099	<b>1PP4 183-4FA□□</b>	135	
22	180 L	1465	143	EFF 2	91.4	0.84	41.5	2.5	6.9	3.2	16	0.117	<b>1PP4 186-4FA□□</b>	150	
30	200 L	1465	196	EFF 2	92.0	0.85	55	2.5	6.7	3.4	16	0.191	<b>1PP4 207-4FA□□</b>	195	
37	225 S	1475	240	EFF 2	92.5	0.85	68	2.5	6.7	3.1	16	0.374	<b>1PP4 220-4FA□□</b>	255	
45	225 M	1475	291	EFF 2	93.4	0.86	81	2.7	7.2	3.2	16	0.447	<b>1PP4 223-4FA□□</b>	290	
55	250 M	1480	355	EFF 2	93.8	0.85	100	2.4	6.1	2.8	16	0.688	<b>1PP4 253-4FA□□</b>	375	
75	280 S	1485	482	EFF 2	94.6	0.85	134	2.5	7.1	3.0	16	1.19	<b>1PP4 280-4FA□□</b>	515	
90	280 M	1485	579	EFF 2	95.0	0.86	160	2.5	7.4	3.0	16	1.39	<b>1PP4 283-4FA□□</b>	560	
110	315 S	1488	706		95.0	0.85	196	2.5	6.4	2.8	16	1.94	<b>1PP4 310-4FA□□</b>	710	
132	315 M	1488	847		95.5	0.85	235	2.7	6.8	2.9	16	2.31	<b>1PP4 313-4FA□□</b>	790	
160	315 L	1486	1028		95.9	0.86	280	2.7	6.8	2.8	16	2.88	<b>1PP4 316-4FA□□</b>	935	
200	315 L	1486	1285		96.1	0.88	340	2.6	6.5	2.8	16	3.46	<b>1PP4 317-4FA□□</b>	1040	

### Order No. supplements

Motor type	Penultimate position: Voltage code				Final position: Type of construction code							
	50 Hz				Without flange	With flange			With standard flange		With special flange	
	230 VΔ/400 VY	400 VΔ/690 VY	500 VY	500 VΔ	IM B3/6/7/8, IM V6/5 without protective cover 1)	IM B5, IM V1 without protective cover 2)	IM V1 without protective cover 2)	IM B35	IM B14, IM V19, IM V18 without protective cover	IM B34	IM B14, IM V19, IM V18 without protective cover	
	1	6	3	5	0	1	8	6	2	7	3	
<b>1PP4 18 . . . . . □□</b>	○	○	○	○	□	✓	–	✓	–	–	–	
<b>1PP4 20 . . . . . □□</b>	○	○	○	○	□	✓	–	✓	–	–	–	
<b>1PP4 22 . . . . . □□</b>	○	○	○	○	□	✓	–	✓	–	–	–	
<b>1PP4 25 . . . . . □□</b>	○	○	○	○	□	✓	–	✓	–	–	–	
<b>1PP4 28 . . . . . □□</b>	○	○	○	○	□	✓	–	✓	–	–	–	
<b>1PP4 310 . . . . . □□</b>	○	○	○	○	□	✓	–	✓	–	–	–	
<b>1PP4 313 . . . . . □□</b>	○	○	○	○	□	✓	–	✓	–	–	–	
<b>1PP4 316 . . . . . □□</b>	–	○	–	○	□ <sup>3)</sup>	–	✓	✓	–	–	–	
<b>1PP4 317 . . . . . □□</b>	–	○	–	○	□ <sup>3)</sup>	–	✓	✓	–	–	–	

- Standard version
- Without additional charge
- ✓ With additional charge
- Not possible

Order other voltages with voltage code **9** in the penultimate position and the corresponding order code (see "Special versions" in the "Selection and ordering data" under "Voltages").

Order other types of construction with type of construction code **9** in the final position and the corresponding order code (see "Special versions" in the "Selection and ordering data" under "Types of construction").

1) If motors 1PP4 183-... to 1PP4 317-... (motor series 1PP4 frame sizes 180 M to 315 L) in types of construction with feet IM B6, IM B7, IM V6 or IM V5 without protective cover are fixed to the wall, it is recommended that the motor feet are supported.

2) Motors 1PP4 220-... to 1PP4 317-... (motor series 1PP4 frame sizes 225 S to 315 L) are supplied with two screw-in eyebolts in accordance with IM B5, whereby one can be relocated in accordance with IM V1 or IM V3. It is important to note that stress must not be applied perpendicular to the ring plane.

3) Type of construction IM V6 and IM V5 without protective cover is only possible using type of construction code **9** and order code **M1E** or **M1D**.

# IEC Squirrel-Cage Motors

## Fan motors

Forced-air cooled, without external fan and fan cover  
with improved efficiency – Cast-iron series 1PP4

### Selection and ordering data (continued)

Rated output at 50 Hz	Frame size	Operating values at rated output					Locked-rotor torque with direct starting as multiple of rated torque	Locked-rotor current	Break-down torque	Torque class	Moment of inertia	Order No. For Order No. supplements for voltage and type of construction, see table below	Price	Weight
		Rated speed at 50 Hz	Rated torque at 50 Hz	Efficiency at 50 Hz 4/4-load	Power factor at 50 Hz 4/4-load	Rated current at 50 Hz 400 V								
$P_{rated}$ kW	FS	$n_{rated}$ rpm	$T_{rated}$ Nm	$\eta_{rated}$ %	$\cos\phi_{rated}$	$I_{rated}$ A	$T_{LR}/T_{rated}$	$I_{LR}/I_{rated}$	$T_B/T_{rated}$	CL	J kg m <sup>2</sup>		Type of construction IM B3 approx. m kg	
<b>6-pole, 1000 rpm at 50 Hz, temperature class 155 (F), IP55 degree of protection</b>														
15	180 L	965	148	89.1	0.83	29.5	2.3	5.3	2.5	16	0.175	<b>1PP4 186-6FA□□</b>	145	
18.5	200 L	975	181	90.2	0.81	36.5	2.5	5.6	2.5	16	0.238	<b>1PP4 206-6FA□□</b>	185	
22	200 L	975	215	90.6	0.81	43.5	2.6	5.7	2.5	16	0.287	<b>1PP4 207-6FA□□</b>	195	
30	225 M	978	293	92.0	0.83	57	2.7	5.6	2.5	16	0.492	<b>1PP4 223-6FA□□</b>	270	
37	250 M	980	361	92.7	0.83	69	2.7	6.0	2.3	16	0.762	<b>1PP4 253-6FA□□</b>	355	
45	280 S	985	436	92.7	0.85	82	2.4	6.1	2.4	16	1.12	<b>1PP4 280-6FA□□</b>	455	
55	280 M	985	533	93.0	0.86	99	2.5	6.3	2.5	16	1.37	<b>1PP4 283-6FA□□</b>	490	
75	315 S	988	725	93.8	0.84	138	2.5	6.5	2.8	16	2.10	<b>1PP4 310-6FA□□</b>	665	
90	315 M	988	870	94.2	0.84	164	2.6	6.8	2.9	16	2.50	<b>1PP4 313-6FA□□</b>	730	
110	315 L	988	1063	94.5	0.86	196	2.5	6.8	2.9	16	3.20	<b>1PP4 316-6FA□□</b>	870	
132	315 L	988	1276	95.0	0.86	235	3.1	7.3	3.0	16	4.02	<b>1PP4 317-6FA□□</b>	960	

### Order No. supplements

Motor type	Penultimate position: Voltage code				Final position: Type of construction code						
	50 Hz				Without flange	With flange		With standard flange		With special flange	
	230 VΔ/400 VY	400 VΔ/690 VY	500 VY	500 VΔ	IM B3/6/7/8, IM V6/5 without protective cover 1)	IM B5, IM V1 without protective cover 2)	IM V1 without protective cover 2)	IM B35	IM B14, IM V19, IM V18 without protective cover	IM B34	IM B14, IM V19, IM V18 without protective cover
	1	6	3	5	0	1	8	6	2	7	3
<b>1PP4 18 - ... □□</b>	○	○	○	○	□	✓	–	✓	–	–	–
<b>1PP4 20 - ... □□</b>	○	○	○	○	□	✓	–	✓	–	–	–
<b>1PP4 22 - ... □□</b>	○	○	○	○	□	✓	–	✓	–	–	–
<b>1PP4 25 - ... □□</b>	○	○	○	○	□	✓	–	✓	–	–	–
<b>1PP4 28 - ... □□</b>	○	○	○	○	□	✓	–	✓	–	–	–
<b>1PP4 310 - ... □□</b>	○	○	○	○	□	✓	–	✓	–	–	–
<b>1PP4 313 - ... □□</b>	○	○	○	○	□	✓	–	✓	–	–	–
<b>1PP4 316 - ... □□</b>	–	○	–	○	□ <sup>3)</sup>	–	✓	✓	–	–	–
<b>1PP4 317 - ... □□</b>	–	○	–	○	□ <sup>3)</sup>	–	✓	✓	–	–	–

- Standard version
- Without additional charge
- ✓ With additional charge
- Not possible

Order other voltages with voltage code **9** in the penultimate position and the corresponding order code (see "Special versions" in the "Selection and ordering data" under "Voltages").

Order other types of construction with type of construction code **9** in the final position and the corresponding order code (see "Special versions" in the "Selection and ordering data" under "Types of construction").

1) If motors 1PP4 183-... to 1PP4 317-... (motor series 1PP4 frame sizes 180 M to 315 L) in types of construction with feet IM B6, IM B7, IM V6 or IM V5 without protective cover are fixed to the wall, it is recommended that the motor feet are supported.

2) Motors 1PP4 220-... to 1PP4 317-... (motor series 1PP4 frame sizes 225 S to 315 L) are supplied with two screw-in eyebolts in accordance with IM B5, whereby one can be relocated in accordance with IM V1 or IM V3. It is important to note that stress must not be applied perpendicular to the ring plane.

3) Type of construction IM V6 and IM V5 without protective cover is only possible using type of construction code **9** and order code **M1E** or **M1D**.

# IEC Squirrel-Cage Motors

## Fan motors

Forced-air cooled, without external fan and fan cover  
with improved efficiency – Cast-iron series 1PP4

### Selection and ordering data (continued)

Rated output at 50 Hz	Frame size	Operating values at rated output					Locked-rotor torque with direct starting as multiple of rated torque	Locked-rotor current	Break-down torque	Torque class	Moment of inertia	Order No. For Order No. supplements for voltage and type of construction, see table below	Price	Weight
		Rated speed at 50 Hz	Rated torque at 50 Hz	Efficiency at 50 Hz 4/4-load	Power factor at 50 Hz 4/4-load	Rated current at 50 Hz 400 V								
$P_{rated}$ kW	FS	$n_{rated}$ rpm	$T_{rated}$ Nm	$\eta_{rated}$ %	$\cos\phi_{rated}$	$I_{rated}$ A	$T_{LR}/T_{rated}$	$I_{LR}/I_{rated}$	$T_B/T_{rated}$	CL	J kg m <sup>2</sup>			
<b>8-pole, 750 rpm at 50 Hz, temperature class 155 (F), IP55 degree of protection</b>														
11	180 L	725	145	87.7	0.73	25	1.7	4.2	2.1	13	0.169	<b>1PP4 186-8FB□□</b>	145	
15	200 L	725	198	87.9	0.76	32.5	2.2	4.9	2.6	13	0.290	<b>1PP4 207-8FB□□</b>	195	
18.5	225 S	730	242	89.5	0.78	38.5	2.3	5.5	2.7	13	0.482	<b>1PP4 220-8FB□□</b>	260	
22	225 M	730	288	89.8	0.79	45	2.3	5.6	2.8	13	0.551	<b>1PP4 223-8FB□□</b>	280	
30	250 M	730	392	91.6	0.81	58	2.3	5.5	2.6	13	0.837	<b>1PP4 253-8FB□□</b>	370	
37	280 S	735	481	92.2	0.81	72	2.2	5.0	2.1	13	1.11	<b>1PP4 280-8FB□□</b>	455	
45	280 M	735	585	92.6	0.81	87	2.2	5.1	2.1	13	1.35	<b>1PP4 283-8FB□□</b>	495	
55	315 S	740	710	93.2	0.81	106	2.2	5.8	2.6	13	2.08	<b>1PP4 310-8FB□□</b>	660	
75	315 M	738	971	93.4	0.83	140	2.2	5.7	2.6	13	2.48	<b>1PP4 313-8FB□□</b>	725	
90	315 L	738	1165	93.5	0.83	168	2.2	5.8	2.7	13	3.14	<b>1PP4 316-8FB□□</b>	845	
110	315 L	738	1423	94.1	0.83	205	2.4	6.1	2.8	13	3.95	<b>1PP4 317-8FB□□</b>	1000	

### Order No. supplements

Motor type	Penultimate position: Voltage code				Final position: Type of construction code						
	50 Hz				Without flange	With flange		With standard flange		With special flange	
	230 VΔ/400 VY	400 VΔ/690 VY	500 VY	500 VΔ	IM B3/6/7/8, IM V6/5 without protective cover <sup>1)</sup>	IM B5, IM V1 without protective cover <sup>2)</sup>	IM V1 without protective cover <sup>2)</sup>	IM B35	IM B14, IM V19, IM V18 without protective cover	IM B34	IM B14, IM V19, IM V18 without protective cover
	1	6	3	5	0	1	8	6	2	7	3
<b>1PP4 18 - ... □□</b>	○	○	○	○	□	✓	–	✓	–	–	–
<b>1PP4 20 - ... □□</b>	○	○	○	○	□	✓	–	✓	–	–	–
<b>1PP4 22 - ... □□</b>	○	○	○	○	□	✓	–	✓	–	–	–
<b>1PP4 25 - ... □□</b>	○	○	○	○	□	✓	–	✓	–	–	–
<b>1PP4 28 - ... □□</b>	○	○	○	○	□	✓	–	✓	–	–	–
<b>1PP4 310 - ... □□</b>	○	○	○	○	□	✓	–	✓	–	–	–
<b>1PP4 313 - ... □□</b>	○	○	○	○	□	✓	–	✓	–	–	–
<b>1PP4 316 - ... □□</b>	–	○	–	○	□ <sup>3)</sup>	–	✓	✓	–	–	–
<b>1PP4 317 - ... □□</b>	–	○	–	○	□ <sup>3)</sup>	–	✓	✓	–	–	–

- Standard version
- Without additional charge
- ✓ With additional charge
- Not possible

Order other voltages with voltage code **9** in the penultimate position and the corresponding order code (see "Special versions" in the "Selection and ordering data" under "Voltages").

Order other types of construction with type of construction code **9** in the final position and the corresponding order code (see "Special versions" in the "Selection and ordering data" under "Types of construction").

<sup>1)</sup> If motors 1PP4 183-... to 1PP4 317-... (motor series 1PP4 frame sizes 180 M to 315 L) in types of construction with feet IM B6, IM B7, IM V6 or IM V5 without protective cover are fixed to the wall, it is recommended that the motor feet are supported.

<sup>2)</sup> Motors 1PP4 220-... to 1PP4 317-... (motor series 1PP4 frame sizes 225 S to 315 L) are supplied with two screw-in eyebolts in accordance with IM B5, whereby one can be relocated in accordance with IM V1 or IM V3. It is important to note that stress must not be applied perpendicular to the ring plane.

<sup>3)</sup> Type of construction IM V6 and IM V5 without protective cover is only possible using type of construction code **9** and order code **M1E** or **M1D**.

# IEC Squirrel-Cage Motors

## Fan motors

Forced-air cooled, without external fan and fan cover  
with increased output – Cast-iron series 1PP4

### Selection and ordering data

Rated output at 50 Hz	Frame size	Operating values at rated output							Locked-rotor torque with direct starting as multiple of rated torque	Locked-rotor current	Break-down torque	Torque class	Moment of inertia	Order No. supplements for voltage and type of construction, see table below	Price	Weight
		Rated speed at 50 Hz	Rated torque at 50 Hz	Efficiency at 50 Hz		Power factor at 50 Hz		Rated current at 50 Hz 400 V								
$P_{rated}$	FS	$n_{rated}$	$T_{rated}$	$\eta_{rated}$	$\eta_{rated}$	$\cos \varphi_{rated}$	$\cos \varphi_{rated}$	$I_{rated}$	$\frac{T_{LR}}{I_{rated}}$	$\frac{I_{LR}}{I_{rated}}$	$\frac{T_B}{I_{rated}}$	J			Type of construction IM B3 approx. m	
kW		rpm	Nm	%	%			A				kg m <sup>2</sup>	CL		kg	
<b>2-pole, 3000 rpm at 50 Hz, temperature class 155 (F), IP55 degree of protection</b>																
30	180 L	2950	97	93.2	93.3	0.86	0.82	54	2.4	7.1	3.4	16	0.086	<b>1PP4 188-2FA□□</b>	170	
45	200 L	2955	145	94.0	94.1	0.89	0.87	78	2.5	6.9	3.2	16	0.182	<b>1PP4 208-2FA□□</b>	245	
55	225 M	2960	177	95.1	95.3	0.89	0.86	94	2.6	7.3	3.2	16	0.266	<b>1PP4 228-2FA□□</b>	325	
75	250 M	2970	241	94.9	94.9	0.88	0.85	130	2.4	7.1	3.1	16	0.483	<b>1PP4 258-2FA□□</b>	405	
110	280 M	2975	353	95.8	95.9	0.90	0.88	184	2.5	7.0	3.0	13	1.00	<b>1PP4 288-2FB□□</b>	610	
<b>4-pole, 1500 rpm at 50 Hz, temperature class 155 (F), IP55 degree of protection</b>																
30	180 L	1465	196	92.0	92.2	0.80	0.76	59	2.6	6.3	2.9	16	0.144	<b>1PP4 188-4FA□□</b>	175	
37	200 L	1465	241	92.8	93.1	0.83	0.78	70	2.6	6.5	3.0	16	0.234	<b>1PP4 208-4FA□□</b>	220	
55	225 M	1475	356	93.6	94.1	0.86	0.83	99	2.5	6.5	2.7	16	0.486	<b>1PP4 228-4FA□□</b>	320	
75	250 M	1482	483	94.5	94.6	0.85	0.81	136	2.5	7.0	3.0	16	0.856	<b>1PP4 258-4FA□□</b>	445	
110	280 M	1488	706	95.5	95.2	0.84	0.78	198	2.8	7.9	3.3	16	1.71	<b>1PP4 288-4FA□□</b>	660	

### Order No. supplements

Motor type	Penultimate position: Voltage code				Final position: Type of construction code						
	50 Hz				Without flange	With flange		With standard flange		With special flange	
	230 VΔ/400 VY	400 VΔ/690 VY	500 VY	500 VΔ	IM B3/6/7/8, IM V6/5 without protective cover <sup>1)</sup>	IM B5, IM V1 without protective cover <sup>2)</sup>	IM B35	IM B14, IM V19, IM V18 without protective cover	IM B34	IM B14, IM V19, IM V18 without protective cover	
	1	6	3	5	0	1	6	2	7	3	
<b>1PP4 188 - ... □□</b>	○	○	○	○	□	✓	✓	-	-	-	
<b>1PP4 208 - ... □□</b>	○	○	○	○	□	✓	✓	-	-	-	
<b>1PP4 228 - ... □□</b>	○	○	○	○	□	✓	✓	-	-	-	
<b>1PP4 258 - ... □□</b>	○	○	○	○	□	✓	✓	-	-	-	
<b>1PP4 288 - ... □□</b>	○	○	○	○	□	✓	✓	-	-	-	

- Standard version
- Without additional charge
- ✓ With additional charge
- Not possible

Order other voltages with voltage code **9** in the penultimate position and the corresponding order code (see "Special versions" in the "Selection and ordering data" under "Voltages").

Order other types of construction with type of construction code **9** in the final position and the corresponding order code (see "Special versions" in the "Selection and ordering data" under "Types of construction").

<sup>1)</sup> If motors 1PP4 188-... to 1PP4 318-... (motor series 1PP4 frame sizes 180 L to 315 L) in types of construction with feet IM B6, IM B7, IM V6 or IM V5 without protective cover are fixed to the wall, it is recommended that the motor feet are supported.

<sup>2)</sup> Motors 1PP4 220-... to 1PP4 318-... (motor series 1PP4 frame sizes 225 S to 315 L) are supplied with two screw-in eyebolts in accordance with IM B5, whereby one can be relocated in accordance with IM V1 or IM V3. It is important to note that stress must not be applied perpendicular to the ring plane.

# IEC Squirrel-Cage Motors

## Fan motors

Forced-air cooled, without external fan and fan cover  
with increased output – Cast-iron series 1PP4

### Selection and ordering data (continued)

Rated output at 50 Hz	Frame size	Operating values at rated output								Locked-rotor torque with direct starting as multiple of rated torque	Locked-rotor current as multiple of rated current	Break-down torque	Torque class	Moment of inertia	Order No. For Order No. supplements for voltage and type of construction, see table below	Price	Weight
		Rated speed at 50 Hz	Rated torque at 50 Hz	Efficiency at 50 Hz		Power factor at 50 Hz		Rated current at 50 Hz	Rated current at 400 V								
$P_{rated}$	FS	$n_{rated}$	$T_{rated}$	$\eta_{rated}$	$\eta_{rated}$	$\cos \phi_{rated}$	$\cos \phi_{rated}$	$I_{rated}$	$I_{LR}/I_{rated}$	$I_{LR}/I_{rated}$	$T_B/I_{rated}$	CL	$J$			Type of construction IM B3 approx. $m$	
kW	rpm	Nm	%	%	%	A							kg m <sup>2</sup>			kg	
<b>6-pole, 1000 rpm at 50 Hz, temperature class 155 (F), IP55 degree of protection</b>																	
18.5	180 L	970	182	89.8	90.5	0.80	0.75	37.5	2.3	4.9	2.4	16	0.203	<b>1PP4 188-6FA□□</b>		170	
30	200 L	975	294	91.1	91.5	0.80	0.75	60	2.6	5.8	2.6	16	0.362	<b>1PP4 208-6FA□□</b>		235	
37	225 M	978	361	92.3	93.1	0.83	0.80	70	2.5	5.9	2.8	16	0.624	<b>1PP4 228-6FA□□</b>		315	
45	250 M	982	438	93.6	94.1	0.83	0.80	84	2.7	6.3	2.3	16	0.934	<b>1PP4 258-6FA□□</b>		390	
75	280 M	985	727	94.0	94.5	0.85	0.80	136	3.0	6.8	2.8	16	1.65	<b>1PP4 288-6FA□□</b>		550	
160	315 L	988	1547	95.2	95.3	0.86	0.82	285	3.0	7.5	3.0	16	4.71	<b>1PP4 318-6FA□□</b>		1160	
<b>8-pole, 750 rpm at 50 Hz, temperature class 155 (F), IP55 degree of protection</b>																	
15	180 L	720	199	88.0	88.7	0.73	0.63	34	2.0	4.5	2.4	13	0.206	<b>1PP4 188-8FB□□</b>		160	
18.5	200 L	725	244	88.4	89.3	0.78	0.72	39	2.4	5.2	2.6	13	0.367	<b>1PP4 208-8FB□□</b>		220	
30	225 M	730	392	90.5	91.3	0.79	0.74	61	2.6	5.6	2.8	13	0.658	<b>1PP4 228-8FB□□</b>		330	
37	25 M	730	484	92.1	93.0	0.82	0.77	71	2.4	5.6	2.6	13	1.06	<b>1PP4 258-8FB□□</b>		415	
55	280 M	735	715	93.1	93.9	0.81	0.77	106	2.4	5.6	2.3	13	1.63	<b>1PP4 288-8FB□□</b>		545	
132	315 L	738	1708	94.3	94.7	0.83	0.79	245	2.5	6.5	2.9	13	4.52	<b>1PP4 318-8FB□□</b>		1080	

### Order No. supplements

Motor type	Penultimate position: Voltage code				Final position: Type of construction code							
	50 Hz				Without flange	With flange			With standard flange		With special flange	
	230 VΔ/400 VY	400 VΔ/690 VY	500 VY	500 VΔ	IM B3/6/7/8, IM V6/5 without protective cover 1)	IM B5, IM V1 without protective cover 2)	IM V1 without protective cover 2)	IM B35	IM B14, IM V19, IM V18 without protective cover	IM B34	IM B14, IM V19, IM V18 without protective cover	
	1	6	3	5	0	1	8	6	2	7	3	
<b>1PP4 188 - ... □□</b>	○	○	○	○	□	✓	–	✓	–	–	–	
<b>1PP4 208 - ... □□</b>	○	○	○	○	□	✓	–	✓	–	–	–	
<b>1PP4 228 - ... □□</b>	○	○	○	○	□	✓	–	✓	–	–	–	
<b>1PP4 258 - ... □□</b>	○	○	○	○	□	✓	–	✓	–	–	–	
<b>1PP4 288 - ... □□</b>	○	○	○	○	□	✓	–	✓	–	–	–	
<b>1PP4 318 - ... □□</b>	–	○	–	○	□ <sup>3)</sup>	–	✓	✓	–	–	–	

- Standard version
- Without additional charge
- ✓ With additional charge
- Not possible

Order other voltages with voltage code **9** in the penultimate position and the corresponding order code (see "Special versions" in the "Selection and ordering data" under "Voltages").

Order other types of construction with type of construction code **9** in the final position and the corresponding order code (see "Special versions" in the "Selection and ordering data" under "Types of construction").

1) If motors 1PP4 188-... to 1PP4 318-... (motor series 1PP4 frame sizes 180 L to 315 L) in types of construction with feet IM B6, IM B7, IM V6 or IM V5 without protective cover are fixed to the wall, it is recommended that the motor feet are supported.

2) Motors 1PP4 220-... to 1PP4 318-... (motor series 1PP4 frame sizes 225 S to 315 L) are supplied with two screw-in eyebolts in accordance with IM B5, whereby one can be relocated in accordance with IM V1 or IM V3. It is important to note that stress must not be applied perpendicular to the ring plane.

3) Type of construction IM V6 and IM V5 without protective cover is only possible using type of construction code **9** and order code **M1E** or **M1D**.

# IEC Squirrel-Cage Motors

## Fan motors

### Special versions

#### Overview

Recommended special versions:

- The connection box is at the non-drive-end (NDE) – Order code **M64**
- 6 protruding cable ends
  - 0.5 m long – Order code **L47**
  - 1.5 m long – Order code **L48**
  - 3.0 m long – Order code **L49**
- Bearings for increased cantilever forces – Order code **K20**

- Special bearing for drive-end (DE) of the motor, reinforced deep-groove bearing (bearing size 63) – Order code **K36**
- Located bearing at drive-end (DE) of motor – Order code **K94**
- Motor protection with PTC thermistors with 3 embedded temperature sensors for tripping – Order code **A11**
- Temperature detectors (bi-metal strip) in motor winding for tripping – Order code **A31**

#### Selection and ordering data

##### Voltages

Additional order codes for other voltages or voltage codes (without “-Z” supplement)

For some non-standard voltages at 50 or 60 Hz, order codes are specified. They are ordered by specifying the code digit **9** for voltage in the 11th position of the Order No. and the appropriate order code.

Special versions	Voltage code 11th position of Order No.	Additional identification code with order code and, if required, with plain text data	Motor type frame size														
			56	63	71	80	90	100	112	132	160	180	200	225	250	280	315 S/M
<b>Self-ventilated motors in pole-changing version</b>																	
<b>Voltage at 60 Hz</b>																	
220 V; 50 Hz output	9	L4A															
220 V; 60 Hz output	9	L4B															
380 V; 50 Hz output	9	L4C															
380 V; 60 Hz output	9	L4D															
440 V; 50 Hz output	9	L4G															
440 V; 60 Hz output	9	L4E															
460 V; 50 Hz output	9	L4J															
460 V; 60 Hz output	9	L4H															
575 V; 50 Hz output	9	L4N															
575 V; 60 Hz output	9	L4M															
<b>Non-standard voltage and/or frequencies</b>																	
Non-standard winding for voltages between 200 and 690 V (voltages outside this range are available on request) <sup>1)</sup>	9	L1Y •															
Non-standard winding for Y/Δ starting at low speed		L3Y •															
<b>1LA7 (aluminum)</b>																	
<b>1LA5 (aluminum)</b>																	
<b>1LG4 (cast-iron)</b>																	
<b>Voltage at 60 Hz</b>																	
220 V; 50 Hz output at 60 Hz	9	L4A															
220 V; 60 Hz output at 60 Hz	9	L4B															
380 V; 50 Hz output	9	L4C															
380 V; 60 Hz output	9	L4D															
440 V; 50 Hz output	9	L4G															
440 V; 60 Hz output	9	L4E															
460 V; 50 Hz output	9	L4J															
460 V; 60 Hz output	9	L4H															
575 V; 50 Hz output	9	L4N															
575 V; 60 Hz output	9	L4M															
<b>Non-standard voltage and/or frequencies</b>																	
Non-standard winding for voltages between 200 and 690 V (voltages outside this range are available on request) <sup>1)</sup>	9	L1Y •															

For legend and footnotes, see Page 7/32.

# IEC Squirrel-Cage Motors

## Fan motors

### Special versions

Special versions	Voltage code	Additional identification code with order code and, if required, with plain text data	Motor type frame size														
			56	63	71	80	90	100	112	132	160	180	200	225	250	280	315 S/M
<b>Forced-air cooled motors without external fan and fan cover</b>																	
			<b>1PP7 (aluminum)</b>										<b>1PP5 (aluminum)</b>				
<b>Voltage at 50 Hz</b>																	
220 VΔ/380 VY (440 VΔ at 60Hz) (210 ... 230 VΔ/360 ... 400 VY); 50 Hz output <sup>2)</sup>	9	L1R	✓	✓	✓	✓	✓	✓	✓	✓	✓	✓	✓	✓	✓	✓	✓
230 VΔ (220 ... 240 VΔ); 50 Hz output <sup>2)</sup>	9	L1E	○	○	○	○	○	○	○	○	○	○	○	○	○	○	○
380 VΔ/660 VY (440 VY at 60 Hz) (360 ... 400 VΔ/625 ... 695 VY); 50 Hz output <sup>2)</sup>	9	L1L	✓	✓	✓	✓	✓	✓	✓	✓	✓	✓	✓	✓	✓	✓	✓
415 VY (395 ... 435 VY); 50 Hz output <sup>2)</sup>	9	L1C	✓	✓	✓	✓	✓	✓	✓	✓	✓	✓	✓	✓	✓	✓	✓
415 VΔ (395 ... 435 VΔ); 50 Hz output <sup>2)</sup>	9	L1D	✓	✓	✓	✓	✓	✓	✓	✓	✓	✓	✓	✓	✓	✓	✓
400 VY (380 ... 420 VY); 50 Hz output <sup>2)</sup>	9	L1A	○	○	○	○	○	○	○	○	○	○	○	○	○	○	○
400 VΔ (380 ... 420 VΔ); 50 Hz output <sup>2)</sup>	9	L1B	○	○	○	○	○	○	○	○	○	○	○	○	○	○	○
400 VΔ (460 VΔ at 60 Hz) (380 ... 420 VΔ); 50 Hz output <sup>2)</sup>	9	L1U	○	○	○	○	○	○	○	○	○	○	○	○	○	○	○
<b>Voltage at 60 Hz</b>																	
220 VΔ/380 VY; 50 Hz output	9	L2A	✓	✓	✓	✓	✓	✓	✓	✓	✓	✓	✓	✓	✓	✓	✓
220 VΔ/380 VY; 60 Hz output	9	L2B	✓	✓	✓	✓	✓	✓	✓	✓	✓	✓	✓	✓	✓	✓	✓
380 VΔ/660 VY; 50 Hz output	9	L2C	✓	✓	✓	✓	✓	✓	✓	✓	✓	✓	✓	✓	✓	✓	✓
380 VΔ/660 VY; 60 Hz output	9	L2D	✓	✓	✓	✓	✓	✓	✓	✓	✓	✓	✓	✓	✓	✓	✓
440 VY; 50 Hz output	9	L2Q	✓	✓	✓	✓	✓	✓	✓	✓	✓	✓	✓	✓	✓	✓	✓
440 VY; 60 Hz output	9	L2W	✓	✓	✓	✓	✓	✓	✓	✓	✓	✓	✓	✓	✓	✓	✓
440 VΔ; 50 Hz output	9	L2R	✓	✓	✓	✓	✓	✓	✓	✓	✓	✓	✓	✓	✓	✓	✓
440 VΔ; 60 Hz output	9	L2X	✓	✓	✓	✓	✓	✓	✓	✓	✓	✓	✓	✓	✓	✓	✓
460 VY; 50 Hz output	9	L2S	✓	✓	✓	✓	✓	✓	✓	✓	✓	✓	✓	✓	✓	✓	✓
460 VY; 60 Hz output	9	L2E	○	○	○	○	○	○	○	○	○	○	○	○	○	○	○
460 VΔ; 50 Hz output	9	L2T	✓	✓	✓	✓	✓	✓	✓	✓	✓	✓	✓	✓	✓	✓	✓
460 VΔ; 60 Hz output	9	L2F	○	○	○	○	○	○	○	○	○	○	○	○	○	○	○
575 VY; 50 Hz output	9	L2U	✓	✓	✓	✓	✓	✓	✓	✓	✓	✓	✓	✓	✓	✓	✓
575 VY; 60 Hz output	9	L2L	✓	✓	✓	✓	✓	✓	✓	✓	✓	✓	✓	✓	✓	✓	✓
575 VΔ; 50 Hz output	9	L2V	✓	✓	✓	✓	✓	✓	✓	✓	✓	✓	✓	✓	✓	✓	✓
575 VΔ; 60 Hz output	9	L2M	✓	✓	✓	✓	✓	✓	✓	✓	✓	✓	✓	✓	✓	✓	✓
<b>Voltage changeover at 60 Hz</b>																	
230 VY/460 VY 60 Hz; 50 Hz output, 9 main terminals and electrical design to NEMA	9	L3E	✓	✓	✓	✓	✓	✓	✓	✓	✓	✓	✓	✓	✓	✓	✓
230 VY/460 VY 60 Hz; 60 Hz output, 9 main terminals and electrical design to NEMA	9	L3F	✓	✓	✓	✓	✓	✓	✓	✓	✓	✓	✓	✓	✓	✓	✓
230 VΔ/460 VΔ 60 Hz; 50 Hz output, 12 main terminals and electrical design to NEMA	9	L3G	-	-	-	-	✓	✓	✓	✓	✓	✓	✓	✓	✓	✓	✓
230 VΔ/460 VΔ 60 Hz; 60 Hz output, 12 main terminals and electrical design to NEMA	9	L3H	-	-	-	-	✓	✓	✓	✓	✓	✓	✓	✓	✓	✓	✓
<b>Non-standard voltage and/or frequencies</b>																	
Non-standard winding for voltages between 200 and 690 V (voltages outside this range are available on request) <sup>1)</sup>	9	L1Y •	✓	✓	✓	✓	✓	✓	✓	✓	✓	✓	✓	✓	✓	✓	✓

# IEC Squirrel-Cage Motors

## Fan motors

### Special versions

Special versions	Voltage code	Additional identification code with order code and, if required, with plain text data	Motor type frame size																	
			56	63	71	80	90	100	112	132	160	180	200	225	250	280	315 S/M	315 L		
<b>1PP4 (cast-iron)</b>																				
<b>Voltage at 50 Hz</b>																				
220 VΔ/380 VY (210 ... 230 VΔ/360 ... 400 VY); 50 Hz output <sup>2)</sup>	9	L1R												✓	✓	✓	✓	✓	✓	–
230 VΔ (220 ... 240 VΔ); 50 Hz output <sup>2)</sup>	9	L1E												○	○	○	○	○	○	–
380 VΔ/660 VY (360 ... 400 VΔ/625 ... 695 VY); 50 Hz output <sup>2)</sup>	9	L1L												✓	✓	✓	✓	✓	✓	✓
415 VY (395 ... 435 VY); 50 Hz output <sup>2)</sup>	9	L1C												✓	✓	✓	✓	✓	✓	–
415 VΔ (395 ... 435 VΔ); 50 Hz output <sup>2)</sup>	9	L1D												✓	✓	✓	✓	✓	✓	✓
400 VY (380 ... 420 VY); 50 Hz output <sup>2)</sup>	9	L1A												○	○	○	○	○	○	–
400 VΔ (380 ... 420 VΔ); 50 Hz output <sup>2)</sup>	9	L1B												○	○	○	○	○	○	○
400 VΔ (460 VΔ at 60Hz) (380 ... 420 VΔ); 50 Hz output <sup>2)</sup>	9	L1U												○	○	○	○	○	○	○
<b>Voltage at 60 Hz</b>																				
220 VΔ/380 VY; 50 Hz output	9	L2A												✓	✓	✓	✓	✓	✓	–
220 VΔ/380 VY; 60 Hz output	9	L2B												✓	✓	✓	✓	✓	✓	–
380 VΔ/660 VY; 50 Hz output	9	L2C												✓	✓	✓	✓	✓	✓	✓
380 VΔ/660 VY; 60 Hz output	9	L2D												✓	✓	✓	✓	✓	✓	✓
440 VY; 50 Hz output	9	L2Q												✓	✓	✓	✓	✓	✓	–
440 VY; 60 Hz output	9	L2W												✓	✓	✓	✓	✓	✓	–
440 VΔ; 50 Hz output	9	L2R												✓	✓	✓	✓	✓	✓	✓
440 VΔ; 60 Hz output	9	L2X												✓	✓	✓	✓	✓	✓	✓
460 VY; 50 Hz output	9	L2S												✓	✓	✓	✓	✓	✓	–
460 VY; 60 Hz output	9	L2E												○	○	○	○	○	○	–
460 VΔ; 50 Hz output	9	L2T												✓	✓	✓	✓	✓	✓	✓
460 VΔ; 60 Hz output	9	L2F												○	○	○	○	○	○	○
575 VY; 50 Hz output	9	L2U												✓	✓	✓	✓	✓	✓	–
575 VY; 60 Hz output	9	L2L												✓	✓	✓	✓	✓	✓	–
575 VΔ; 50 Hz output	9	L2V												✓	✓	✓	✓	✓	✓	✓
575 VΔ; 60 Hz output	9	L2M												○	○	○	○	○	○	○
<b>Non-standard voltage and/or frequencies</b>																				
Non-standard winding for voltages between 200 and 690 V (voltages outside this range are available on request) <sup>1)</sup>	9	L1Y •												✓	✓	✓	✓	✓	✓	✓

- Without additional charge
- ✓ With additional charge
- Not possible
- This order code only determines the price of the version – Additional plain text is required.

1) Plain text must be specified in the order: Voltage, frequency, circuit, required rated output in kW.

2) With order codes **L1A, L1B, L1C, L1D, L1E, L1L, L1R** and **L1U**, a rated voltage range is also specified on the rating plate.



# IEC Squirrel-Cage Motors

## Fan motors

### Special versions

#### Types of construction

Additional order codes for other types of construction or type of construction codes (without "-Z" supplement)

Order codes have been defined for some special types of construction. They are ordered by specifying the code digit **9** for the type of construction in the 12th position of the Order No. and the appropriate order code.

Special versions	Voltage code	Additional identification code with order code and, if required, with plain text data	Motor type frame size														
			56	63	71	80	90	100	112	132	160	180	200	225	250	280	315 S/M
<b>Self-ventilated motors in pole-changing version</b>																	
<b>Without flange</b>																	
IM V5 with protective cover <sup>1)</sup>	9	M1F	✓	✓	✓	✓	✓	✓	✓	✓	✓	✓	✓	✓	✓	✓	✓
<b>With flange (acc. to DIN EN 50347)</b>																	
IM V3 <sup>2)</sup>	9	M1G	-	-	-	-	-	-	-	-	-	-	-	-	✓	✓	-
<b>With standard flange</b>																	
IM V18 with protective cover <sup>1)</sup>	9	M2A	✓	✓	✓	✓	✓	✓	✓	✓	✓	✓	✓	✓	-	-	-
<b>With special flange</b>																	
IM V18 with protective cover <sup>1)</sup>	9	M2B	✓	✓	✓	✓	✓	✓	✓	✓	✓	✓	✓	✓	-	-	-
IM B34	9	M2C	✓	✓	✓	✓	✓	✓	✓	✓	✓	✓	✓	✓	-	-	-
<b>Without flange</b>																	
IM V5 without protective cover <sup>3)</sup>	9	M1D	-	-	-	-	-	-	-	-	-	-	-	-	-	-	○
IM V6 <sup>3)</sup>	9	M1E	-	-	-	-	-	-	-	-	-	-	-	-	-	-	○
IM V5 with protective cover <sup>1) 3)</sup>	9	M1F	✓	✓	✓	✓	✓	✓	✓	✓	✓	✓	✓	✓	✓	✓	✓
<b>With flange (acc. to DIN EN 50347):</b>																	
IM V3 <sup>4)</sup>	9	M1G	-	-	-	-	-	-	-	-	-	-	-	-	✓	✓	-
<b>Forced-air cooled motors without external fan and fan cover</b>																	
<b>Without flange</b>																	
IM V5 with protective cover <sup>1)</sup>	9	M1F	✓	✓	✓	✓	✓	✓	✓	✓	✓	✓	✓	✓	✓	✓	✓
<b>With flange (acc. to DIN EN 50347)</b>																	
IM V3 <sup>2)</sup>	9	M1G	-	-	-	-	-	-	-	-	-	-	-	-	✓	✓	-
<b>With standard flange</b>																	
IM V18 with protective cover <sup>1)</sup>	9	M2A	✓	✓	✓	✓	✓	✓	✓	✓	✓	✓	✓	✓	-	-	-
<b>With special flange</b>																	
IM V18 with protective cover <sup>1)</sup>	9	M2B	✓	✓	✓	✓	✓	✓	✓	✓	✓	✓	✓	✓	-	-	-
IM B34	9	M2C	✓	✓	✓	✓	✓	✓	✓	✓	✓	✓	✓	✓	-	-	-
<b>Without flange</b>																	
IM V5 without protective cover <sup>3)</sup>	9	M1D	-	-	-	-	-	-	-	-	-	-	-	-	-	-	✓ <sup>5)</sup> ○
IM V6 <sup>3)</sup>	9	M1E	-	-	-	-	-	-	-	-	-	-	-	-	-	-	✓ <sup>5)</sup> ○
IM V5 with protective cover <sup>1) 3)</sup>	9	M1F	✓	✓	✓	✓	✓	✓	✓	✓	✓	✓	✓	✓	✓	✓	✓ <sup>5)</sup> ✓
<b>With flange (acc. to DIN EN 50347)</b>																	
IM V3 <sup>4)</sup>	9	M1G	-	-	-	-	-	-	-	-	-	-	-	-	✓	✓	-

- Without additional charge  
 ✓ With additional charge  
 - Not possible

<sup>1)</sup> The "Second shaft extension" option, order code K16 is not possible.

<sup>2)</sup> For frame sizes 180 M to 225 M, motors 1LA5/1PP5 can be supplied with two additional eyebolts; state Order No. suffix "Z" and order code **K32**.

<sup>3)</sup> If motors of frame sizes 180 M to 315 L are mounted on the wall, it is recommended that the motor feet are supported.

<sup>4)</sup> Motors 1LG4 of frame sizes 225 S to 315 L are supplied with two screw-in eyebolts in accordance with IM B5, whereby one can be relocated in accordance with IM V1 or IM V3. It is important to note that stress must not be applied perpendicular to the ring plane.

<sup>5)</sup> 60 Hz version is possible on request.

# IEC Squirrel-Cage Motors

## Fan motors

### Special versions

#### Options

Options or order codes (supplement **-Z** is required)

Special versions	Additional identification code <b>-Z</b> with order code and plain text if required	Motor type frame size														
		56	63	71	80	90	100	112	132	160	180	200	225	250	280	315
<b>Self-ventilated motors in pole-changing version</b>																
					<b>1LA7 (aluminum)</b>					<b>1LA5 (aluminum)</b>						
<b>Motor protection</b>																
Motor protection with PTC thermistors with 3 embedded temperature sensors for tripping <sup>1)</sup>	<b>A11</b>				✓	✓	✓	✓	✓	✓	✓	✓	✓	✓	✓	✓
Motor protection with PTC thermistors with 6 embedded temperature sensors for tripping and alarm <sup>1)</sup>	<b>A12</b>				✓	✓	✓	✓	✓	✓	✓	✓	✓	✓	✓	✓
Motor temperature detection with embedded temperature sensor KTY 84-130 <sup>1)</sup>	<b>A23</b>				✓	✓	✓	✓	✓	✓	✓	✓	✓	✓	✓	✓
Motor temperature detection with embedded temperature sensors 2 x KTY 84-130 <sup>1)</sup>	<b>A25</b>				✓	✓	✓	✓	✓	✓	✓	✓	✓	✓	✓	✓
Temperature detectors for tripping <sup>1)</sup>	<b>A31</b>				✓	✓	✓	✓	✓	✓	✓	✓	✓	✓	✓	✓
Installation of 3 PT 100 resistance thermometers <sup>1)</sup>	<b>A60</b>				–	–	✓	✓	✓	✓	✓	✓	✓	✓	✓	✓
<b>Motor connection and connection box</b>																
Connection box on RHS	<b>K09</b>				✓	✓	✓	✓	✓	✓	✓	✓	✓	✓	✓	✓
Connection box on LHS	<b>K10</b>				✓	✓	✓	✓	✓	✓	✓	✓	✓	✓	✓	✓
One cable gland, metal	<b>K54</b>				✓	✓	✓	✓	✓	✓	✓	✓	✓	✓	✓	✓
Cable gland, maximum configuration	<b>K55</b>				✓	✓	✓	✓	✓	✓	✓	✓	✓	✓	✓	✓
Rotation of the connection box through 90°, entry from DE	<b>K83</b>				✓	✓	✓	✓	✓	✓	✓	✓	✓	✓	✓	✓
Rotation of the connection box through 90°, entry from NDE	<b>K84</b>				✓	✓	✓	✓	✓	✓	✓	✓	✓	✓	✓	✓
Rotation of connection box through 180°	<b>K85</b>				✓	✓	○	○	○	○	✓	✓	✓	✓	✓	✓
Next larger connection box	<b>L00</b>				–	–	–	–	–	–	✓	✓	✓	✓	✓	✓
External earthing	<b>L13</b>				✓	✓	✓	✓	✓	✓	✓	✓	✓	✓	✓	✓
3 cables protruding, 0.5 m long <sup>2)</sup>	<b>L44</b>				✓	✓	✓	✓	✓	✓	✓	✓	✓	O. R.	O. R.	✓
3 cables protruding, 1.5 m long <sup>2)</sup>	<b>L45</b>				✓	✓	✓	✓	✓	✓	✓	✓	✓	O. R.	O. R.	✓
6 cables protruding, 0.5 m long <sup>2)</sup>	<b>L47</b>				✓	✓	✓	✓	✓	✓	✓	✓	✓	O. R.	O. R.	✓
6 cables protruding, 1.5 m long <sup>2)</sup>	<b>L48</b>				✓	✓	✓	✓	✓	✓	✓	✓	✓	✓	✓	✓
6 cables protruding, 3 m long <sup>2)</sup>	<b>L49</b>				✓	✓	✓	✓	✓	✓	✓	✓	✓	✓	✓	✓
Connection box on NDE	<b>M64</b>				✓	✓	✓	✓	✓	✓	✓	✓	✓	✓	✓	✓
Terminal strip for main and auxiliary terminals	<b>M69</b>				✓	✓	–	–	–	–	–	–	–	–	–	–
<b>Windings and insulation</b>																
Temperature class 155 (F), used acc. to 155 (F), with service factor (SF)	<b>C11</b>				✓	✓	✓	✓	✓	✓	✓	✓	✓	✓	✓	✓
Temperature class 155 (F), used acc. to 155 (F), with increased output	<b>C12</b>				✓	✓	✓	✓	✓	✓	✓	✓	✓	✓	✓	✓
Temperature class 155 (F), used acc. to 155 (F), with increased coolant temperature	<b>C13</b>				✓	✓	✓	✓	✓	✓	✓	✓	✓	✓	✓	✓
Temperature class 180 (H) at rated output and max. CT 60 °C <sup>3)</sup>	<b>C18</b>				✓	✓	✓	✓	✓	✓	✓	✓	✓	✓	✓	✓

For legend and footnotes, see Page 7/38.

# IEC Squirrel-Cage Motors

## Fan motors

### Special versions

Special versions	Additional identification code <b>-Z</b> with order code and plain text if required	Motor type frame size														
		56	63	71	80	90	100	112	132	160	180	200	225	250	280	315
<b>Self-ventilated motors in pole-changing version</b>																
					<b>1LA7 (aluminum)</b>						<b>1LA5 (aluminum)</b>					
<b>Windings and insulation (continued)</b>																
Increased air humidity/temperature with 30 to 60 g water per m <sup>3</sup> of air	<b>C19</b>				✓	✓	✓	✓	✓	✓	✓	✓	✓	✓	✓	✓
Temperature class 155 (F), used acc. to 130 (B), coolant temperature 45 °C, derating approx. 4 %	<b>C22</b>				✓	✓	✓	✓	✓	✓	✓	✓	✓	✓	✓	✓
Temperature class 155 (F), used acc. to 130 (B), coolant temperature 50 °C, derating approx. 8 %	<b>C23</b>				✓	✓	✓	✓	✓	✓	✓	✓	✓	✓	✓	✓
Temperature class 155 (F), used acc. to 130 (B), coolant temperature 55 °C, derating approx. 13 %	<b>C24</b>				✓	✓	✓	✓	✓	✓	✓	✓	✓	✓	✓	✓
Temperature class 155 (F), used acc. to 130 (B), coolant temperature 60 °C, derating approx. 18 %	<b>C25</b>				✓	✓	✓	✓	✓	✓	✓	✓	✓	✓	✓	✓
Increased air humidity/temperature with 60 to 100 g water per m <sup>3</sup> of air	<b>C26</b>				✓	✓	✓	✓	✓	✓	✓	✓	✓	✓	✓	✓
Temperature class 155 (F), used acc. to 130 (B), with increased coolant temperature and/or site altitude	<b>Y50 •</b> and specified output, CT... °C or SA .... m above sea level				✓	✓	✓	✓	✓	✓	✓	✓	✓	✓	✓	✓
Temperature class 155 (F), used acc. to 155 (F), other requirements	<b>Y52 •</b> and specify output, CT... °C or SA .... m above sea level				✓	✓	✓	✓	✓	✓	✓	✓	✓	✓	✓	✓
<b>Colors and paint finish</b>																
Special finish in RAL 7030 stone gray					□	□	□	□	□	□	□	□	□	□	□	□
Special finish in other standard RAL colors: RAL 1002, 1013, 1015, 1019, 2003, 2004, 3000, 3007, 5007, 5009, 5010, 5012, 5015, 5017, 5018, 5019, 6011, 6019, 6021, 7000, 7001, 7004, 7011, 7016, 7022, 7031, 7032, 7033, 7035, 9001, 9002, 9005 Page 0/18	<b>Y54 •</b> and special finish RAL ....				✓	✓	✓	✓	✓	✓	✓	✓	✓	✓	✓	✓
Special finish in special RAL colors: For RAL colors, see "Special finish in special RAL colors" on Page 0/19	<b>Y51 •</b> and special finish RAL ....				✓	✓	✓	✓	✓	✓	✓	✓	✓	✓	✓	✓
Sea air resistant special finish	<b>M94</b>				O. R.	O. R.	O. R.	O. R.	O. R.	O. R.	O. R.	O. R.	O. R.	O. R.	O. R.	O. R.
Unpainted (only cast iron parts primed)	<b>K23</b>				○	○	○	○	○	○	○	○	○	○	○	○
Unpainted, only primed	<b>K24</b>				✓	✓	✓	✓	✓	✓	✓	✓	✓	✓	✓	✓

## IEC Squirrel-Cage Motors

## Fan motors

## Special versions

Special versions	Additional identification code <b>-Z</b> with order code and plain text if required	Motor type frame size														
		56	63	71	80	90	100	112	132	160	180	200	225	250	280	315
<b>Self-ventilated motors in pole-changing version</b>																
										1LA7 (aluminum)					1LA5 (aluminum)	
<b>Modular technology – Basic versions <sup>4)</sup></b>																
Mounting of separately driven fan	<b>G17</b>									✓	✓	✓	✓	✓	✓	
Mounting of brake <sup>5)</sup>	<b>G26</b>									✓	✓	✓	✓	✓	✓	
Mounting of 1XP8 001-1 (HTL) rotary pulse encoder	<b>H57</b>									✓	✓	✓	✓	✓	✓	
Mounting of 1XP8 001-2 (TTL) rotary pulse encoder	<b>H58</b>									✓	✓	✓	✓	✓	✓	
<b>Modular technology – Combinations of basic versions <sup>4)</sup></b>																
Mounting of separately driven fan and 1XP8 001-1 rotary pulse encoder	<b>H61</b>									✓	✓	✓	✓	✓	✓	
Mounting of brake and 1XP8 001-1 rotary pulse encoder <sup>5)</sup>	<b>H62</b>									✓	✓	✓	✓	✓	✓	
Mounting of brake and separately driven fan	<b>H63</b>									✓	✓	✓	✓	✓	✓	
Mounting of brake, separately driven fan and 1XP8 001-1 rotary pulse encoder <sup>5)</sup>	<b>H64</b>									✓	✓	✓	✓	✓	✓	
Mounting of separately driven fan and 1XP8 001-2 rotary pulse encoder	<b>H97</b>									✓	✓	✓	✓	✓	✓	
Mounting of brake and 1XP8 001-2 rotary pulse encoder <sup>5)</sup>	<b>H98</b>									✓	✓	✓	✓	✓	✓	
Mounting of brake, separately driven fan and 1XP8 001-2 rotary pulse encoder <sup>5)</sup>	<b>H99</b>									✓	✓	✓	✓	✓	✓	
<b>Modular technology – Additional versions</b>																
Brake supply voltage 24 V DC	<b>C00</b>									✓	✓	✓	✓	✓	✓	
Brake supply voltage 400 V AC	<b>C01</b>									✓	✓	✓	✓	✓	✓	
Mechanical manual release of the brake with operating lever	<b>K82</b>									✓	✓	✓	✓	✓	✓	
<b>Special technology <sup>4)</sup></b>																
Prepared for mounting MMI <sup>6)</sup>	<b>H15</b>									✓	✓	✓	✓	✓	-	-
Mounting of LL 861 900 220 rotary pulse encoder	<b>H70</b>									-	-	✓	✓	✓	✓	
Mounting of HOG 9 D 1024 I rotary pulse encoder	<b>H72</b>									-	-	✓	✓	✓	✓	
Mounting of HOG 10 D 1024 I rotary pulse encoder	<b>H73</b>									-	-	✓	✓	✓	✓	
Prepared for mounting LL 861 900 220	<b>H78</b>									-	-	✓	✓	✓	✓	
Prepared for mounting HOG 9 D 1024 I	<b>H79</b>									-	-	✓	✓	✓	✓	
Prepared for mounting HOG 10 D 1024 I	<b>H80</b>									-	-	✓	✓	✓	✓	
<b>Mechanical design and degrees of protection</b>																
Drive-end (DE) seal for flange-mounting motors with oil resistance to 0.1 bar Not possible for IM V3 type of construction	<b>K17</b>									✓	✓	✓	✓	✓	✓	
With two additional eyebolts for IM V1/IM V3	<b>K32</b>									-	-	-	-	-	✓	✓
IP65 degree of protection <sup>7)</sup>	<b>K50</b>									✓	✓	✓	✓	✓	✓	
IP56 degree of protection (non-heavy-sea) <sup>8)</sup>	<b>K52</b>									✓	✓	✓	✓	✓	✓	
Vibration-proof version	<b>L03</b>									✓	✓	✓	✓	✓	✓	
Condensation drainage holes <sup>9)</sup>	<b>L12</b>									✓	✓	✓	✓	✓	✓	
Non-rusting screws (externally)	<b>M27</b>									✓	✓	✓	✓	✓	✓	
Mechanical protection for encoder <sup>10)</sup>	<b>M68</b>									✓	✓	✓	✓	✓	✓	

For legend and footnotes, see Page 7/38.

# IEC Squirrel-Cage Motors

## Fan motors

### Special versions

Special versions	Additional identification code -Z with order code and plain text if required	Motor type frame size														
		56	63	71	80	90	100	112	132	160	180	200	225	250	280	315
<b>Self-ventilated motors in pole-changing version</b>																
					1LA7 (aluminum)						1LA5 (aluminum)					
<b>Coolant temperature and site altitude</b>																
Coolant temperature -40 to +40 °C	D03				✓	✓	✓	✓	✓	✓	✓	✓	✓	✓	✓	✓
Coolant temperature -30 to +40 °C	D04				✓	✓	✓	✓	✓	✓	✓	✓	✓	✓	✓	✓
<b>Designs in accordance with standards and specifications</b>																
CCC China Compulsory Certification <sup>11)</sup>	D01				✓	✓	✓	✓	–	–	–	–	–	–	–	–
Electrical according to NEMA MG1-12	D30				✓	✓	✓	✓	✓	✓	✓	✓	✓	✓	✓	✓
Design according to IUL with "Recognition Mark" <sup>12)</sup>	D31				✓	✓	✓	✓	✓	✓	✓	✓	✓	✓	✓	✓
Canadian regulations (CSA) <sup>13)</sup>	D40				✓	✓	✓	✓	✓	✓	✓	✓	✓	✓	✓	✓
PSE Mark Japan <sup>14)</sup>	D46				✓	✓	✓	✓	✓	–	–	–	–	–	–	–
<b>Bearings and lubrication</b>																
Measuring nipple for SPM shock pulse measurement for bearing inspection <sup>15)</sup>	G50				–	–	✓	✓	✓	✓	✓	✓	✓	✓	✓	✓
Bearing design for increased cantilever forces	K20				–	–	✓	✓	✓	✓	✓	✓	✓	✓	✓	✓
Regreasing device <sup>15)</sup>	K40				–	–	✓	✓	✓	✓	✓	✓	✓	✓	✓	✓
Located bearing DE	K94				✓	✓	✓	✓	✓	✓	✓	✓	✓	✓	✓	✓
Located bearing NDE	L04				✓	✓	✓	✓	✓	✓	□	□	□	□	□	
<b>Balance and vibration quantity</b>																
Vibration quantity A					□	□	□	□	□	□	□	□	□	□	□	□
Vibration quantity B	K02				✓	✓	✓	✓	✓	✓	✓	✓	✓	✓	✓	✓
Full key balancing	L68				✓	✓	✓	✓	✓	✓	✓	✓	✓	✓	✓	✓
Balancing without key	M37				✓	✓	✓	✓	✓	✓	✓	✓	✓	✓	✓	✓
<b>Shaft and rotor</b>																
Concentricity of shaft extension, coaxiality and linear movement in accordance with DIN 42955 Tolerance R for flange-mounting motors <sup>16)</sup>	K04				✓	✓	✓	✓	✓	✓	✓	✓	✓	✓	✓	✓
Second standard shaft extension	K16				✓	✓	✓	✓	✓	✓	✓	✓	✓	✓	✓	✓
Shaft extension with normal dimensions without featherkey way	K42				✓	✓	✓	✓	✓	✓	✓	✓	✓	✓	✓	✓
Concentricity of shaft extension in accordance with DIN 42955 Tolerance R	L39				✓	✓	✓	✓	✓	✓	✓	✓	✓	✓	✓	✓
Standard shaft made of non-rusting steel	M65				✓	✓	✓	✓	✓	✓	✓	✓	✓	✓	✓	✓
Non-standard cylindrical shaft extension <sup>17)</sup>	Y55 • and identification code				✓	✓	✓	✓	✓	✓	✓	✓	✓	✓	✓	✓
<b>Heating and ventilation</b>																
Fan cover for textile industry	H17				✓	✓	✓	✓	✓	✓	✓	✓	✓	✓	✓	✓
Metal external fan <sup>18)</sup>	K35				✓	✓	✓	✓	✓	✓	✓	✓	✓	✓	✓	✓
Anti-condensation heaters for 230 V	K45				✓	✓	✓	✓	✓	✓	✓	✓	✓	✓	✓	✓
Anti-condensation heaters for 115 V	K46				✓	✓	✓	✓	✓	✓	✓	✓	✓	✓	✓	✓
<b>Rating plate and extra rating plates</b>																
Second lubricating plate, supplied loose	B06				–	–	✓	✓	✓	✓	✓	✓	✓	✓	✓	✓
Second rating plate, loose	K31				✓	✓	✓	✓	✓	✓	✓	✓	✓	✓	✓	✓
Extra rating plate or rating plate with deviating rating plate data	Y80 • and identification code				✓	✓	✓	✓	✓	✓	✓	✓	✓	✓	✓	✓
Extra rating plate with identification code	Y82 • and identification code				✓	✓	✓	✓	✓	✓	✓	✓	✓	✓	✓	✓
Additional information on rating plate and on package label (maximum of 20 characters)	Y84 • and identification code				✓	✓	✓	✓	✓	✓	✓	✓	✓	✓	✓	✓

For legend and footnotes, see Page 7/38.

# IEC Squirrel-Cage Motors

## Fan motors

### Special versions

Special versions	Additional identification code <b>-Z</b> with order code and plain text if required	Motor type frame size														
		56	63	71	80	90	100	112	132	160	180	200	225	250	280	315
<b>Self-ventilated motors in pole-changing version</b>																
<b>Packaging, safety notes, documentation and test certificates</b>																
Without safety and commissioning note. Customer's declaration of renouncement required.	<b>B00</b>															
With one safety and startup guide per box pallet	<b>B01</b>															
Acceptance test certificate 3.1 according to EN 10204	<b>B02</b>															
Operating instructions German/English enclosed in print	<b>B23</b>															
Type test with heat run for horizontal motors, with acceptance	<b>F83</b>															
Wire-lattice pallet	<b>L99</b>															
Connected in star for dispatch	<b>M32</b>															
Connected in delta for dispatch	<b>M33</b>															

- Standard version
- Without additional charge
- This order code only determines the price of the version – Additional plain text is required.
- , R. Possible on request
- ✓ With additional charge
- Not possible

7

- 1) Evaluation with appropriate tripping unit (see Catalog LV 1) is recommended. For pole-changing motors with separate windings, the number of temperature sensors must be doubled (order code **A11**, price of **A12** or order code **A12**, price available on request).
- 2) In combination with the PTC thermistor option or anti-condensation heating option, please inquire before ordering.
- 3) Cannot be used for motors in UL version (order code **D31**). Cannot be used for motors according to CSA approval (order code **D40**) for motor series 1LA5 frame size 180 to 200. The grease lifetime specified in catalog part 0 "Introduction" refers to CT 40 °C. When the coolant temperature rises by 10 K, the grease lifetime or relubrication interval is halved.
- 4) A second shaft extension is not possible. Please inquire for mounted brakes. The order codes listed cannot be combined within the various technologies nor with each other within the same technology system. This applies for:
  - Modular technology
  - Basic versions of "Modular technology"
  - Combination of special versions "Special technology"
- 5) The standard brake supply voltage is 230 V AC, 50/60 Hz. Other brake supply voltages are possible with order codes **C00** and **C01**.
- 6) Converter mounting is possible for 230 VΔ/400 VY, please also specify Order No. of the MICROMASTER 411 according to Catalog DA 51.3.
- 7) Not possible in combination with rotary pulse encoder HOG 9 D 1024I (order code **H72**, **H79**) and / or brake 2LM8 (used for motors up to and including frame size 225, order code **G26**).
- 8) Not possible in combination with brake 2LM8 (used for motors up to and including frame size 225, order code **G26**).
- 9) Supplied with the condensation drainage holes sealed at the drive end DE and non-drive end NDE for IP55, IP56 and IP65 degrees of protection. If condensation drainage holes are required in motors of the IM B6, IM B7 or IM B8 type of construction (feet located on side or top), it is necessary to relocate the bearing plates at the drive end (DE) and non-drive end (NDE) so that the condensation drainage holes situated between the feet on delivery are underneath.
- 10) Not necessary when a rotary pulse encoder is combined with a separately driven fan, because in this case the rotary pulse encoder is installed under the fan cover.
- 11) CCC certification is required for
  - 2-pole motors ≤2.2 kW
  - 4-pole motors ≤1.1 kW
  - 6-pole motors ≤0.75 kW
  - 8-pole motors ≤0.55 kW
- 12) Possible up to 600 V max. Order with voltage code **9** and order code for voltage and frequency. The rated voltage is indicated on the rating plate.
- 13) Order with voltage code **9** and order code for voltage and frequency. The rated voltage is indicated on the rating plate.
- 14) "Small power motors" with a rated output of up to 3 kW which are exported to Japan must bear the marking.
- 15) Not possible when brake is mounted.
- 16) Can be combined with deep-groove bearings of series 60... 62.. and 63... Not possible with parallel roller bearings (e.g. bearings for increased cantilever forces, order code **K20**), brake or encoder mounting.
- 17) When motors are ordered that have a longer or shorter shaft extension than normal, the required position and length of the featherkey way must be specified in a sketch. It must be ensured that only featherkeys in accordance with DIN 6885, Form A are permitted to be used. The featherkey way is positioned centrally on the shaft extension. The length is defined by the manufacturer normatively. Not valid for: Conical shafts, non-standard threaded journals, non-standard shaft tolerances, friction welded journals, extremely "thin" shafts, special geometry dimensions (e.g. square journals), hollow shafts. Valid for non-standard shaft extensions DE or NDE. The featherkeys are supplied in every case. For order codes **Y55** and **K16**:
  - Dimensions D and DA ≤ internal diameter of roller bearing (see dimension tables under "Dimensions")
  - Dimensions E and EA ≤2 x length E (normal) of the shaft extension
 For an explanation of the order codes, see catalog part 0 "Introduction".
- 18) For 1LA5/6/7/9 motors and 1LG with metal external fan, converter-fed operation is permitted.

# IEC Squirrel-Cage Motors

## Fan motors

### Special versions

Options or order codes (supplement **-Z** is required)

Special versions	Additional identification code <b>-Z</b> with order code and plain text if required	Motor type frame size															
		56	63	71	80	90	100	112	132	160	180	200	225	250	280	315	
<b>Self-ventilated motors in pole-changing version</b>																	
<b>1LG4 (cast-iron)</b>																	
<b>Motor protection</b>																	
Motor protection with PTC thermistors with 3 embedded temperature sensors for tripping <sup>1)</sup>	<b>A11</b>											✓	✓	✓	✓	✓	✓
Motor protection with PTC thermistors with 6 embedded temperature sensors for tripping and alarm <sup>1)</sup>	<b>A12</b>											✓	✓	✓	✓	✓	✓
Motor temperature detection with embedded temperature sensor KTY 84-130 <sup>1)</sup>	<b>A23</b>											✓	✓	✓	✓	✓	✓
Motor temperature detection with embedded temperature sensors 2 x KTY 84-130 <sup>1)</sup>	<b>A25</b>											✓	✓	✓	✓	✓	✓
Temperature detectors for tripping <sup>1)</sup>	<b>A31</b>											✓	✓	✓	✓	✓	✓
Installation of 3 PT 100 resistance thermometers <sup>1)</sup>	<b>A60</b>											✓	✓	✓	✓	✓	✓
Installation of 6 PT 100 resistance thermometers in stator winding <sup>1)</sup>	<b>A61</b>											✓	✓	✓	✓	✓	✓
Installation of 2 PT 100 screw-in resistance thermometers (basic circuit) for rolling-contact bearings <sup>1)</sup>	<b>A72</b>											✓	✓ <sup>2)</sup>	✓	✓	✓	✓
Installation of 2 PT 100 screw-in resistance thermometers (3-wire circuit) for rolling-contact bearings <sup>1)</sup>	<b>A78</b>											✓	✓ <sup>2)</sup>	✓	✓	✓	✓
Installation of 2 PT 100 double screw-in resistance thermometers (3-wire circuit) for rolling-contact bearings <sup>1)</sup>	<b>A80</b>											✓	✓ <sup>2)</sup>	✓	✓	✓	✓
<b>Motor connection and connection box</b>																	
Two-part plate on connection box	<b>K06</b>											–	✓	✓	✓	✓	✓
Connection box on RHS	<b>K09</b>											✓	✓	✓	✓	✓	✓
Connection box on LHS	<b>K10</b>											✓	✓	✓	✓	✓	✓
Connection box on top, feet screwed on	<b>K11</b>											✓	✓	✓	✓	✓	✓
Connection box in cast-iron version	<b>K15</b>											✓	✓	✓	□	□	□
One cable gland, metal	<b>K54</b>											✓	✓	✓	✓	✓	✓
Cable gland, maximum configuration	<b>K55</b>											✓	✓	✓	✓	✓	✓
Rotation of the connection box through 90°, entry from DE	<b>K83</b>											✓	✓	✓	✓	✓	✓
Rotation of the connection box through 90°, entry from NDE	<b>K84</b>											✓	✓	✓	✓	✓	✓
Rotation of connection box through 180°	<b>K85</b>											✓	✓	✓	✓	✓	✓
Next larger connection box	<b>L00</b>											✓	✓	✓	✓	✓	✓
Undrilled entry plate	<b>L01</b>											○	○	○	○	○	○
External earthing	<b>L13</b>											□	□	□	□	□	□
6 cables protruding, 1.5 m long <sup>3)</sup>	<b>L48</b>											✓	✓	✓	O. R.	O. R.	O. R.
6 cables protruding, 3 m long <sup>3)</sup>	<b>L49</b>											✓	✓	✓	O. R.	O. R.	O. R.
Protruding cable ends – right side <sup>3)4)</sup>	<b>L51</b>											O. R.	O. R.	O. R.	O. R.	O. R.	O. R.
Protruding cable ends – left side <sup>3)4)</sup>	<b>L52</b>											O. R.	O. R.	O. R.	O. R.	O. R.	O. R.
Auxiliary connection box 1XB3 020	<b>L97</b>											✓	✓	✓	✓	✓	✓

For legend, see Page 7/43, for footnotes, see Page 7/44.

# IEC Squirrel-Cage Motors

## Fan motors

### Special versions

Special versions	Additional identification code -Z with order code and plain text if required	Motor type frame size														
		56	63	71	80	90	100	112	132	160	180	200	225	250	280	315
<b>Self-ventilated motors in pole-changing version</b>																
<b>1LG4 (cast-iron)</b>																
<b>Motor connection and connection box (continued)</b>																
Stud terminal for cable connection, accessories pack (3 items)	<b>M46</b>													✓	✓	✓
Saddle terminal for connection without cable lug, accessories pack (6 items)	<b>M47</b>													✓	✓	✓
<b>Windings and insulation</b>																
Temperature class 155 (F), used acc. to 155 (F), with service factor (SF)	<b>C11</b>													✓	✓	✓
Temperature class 155 (F), used acc. to 155 (F), with increased output <sup>5)</sup>	<b>C12</b>													✓	✓	✓
Temperature class 155 (F), used acc. to 155 (F), with increased coolant temperature	<b>C13</b>													✓	✓	✓
Temperature class 180 (H) at rated output and max. CT 60 °C <sup>6)</sup>	<b>C18</b>													✓	✓	✓
Increased air humidity/temperature with 30 to 60 g water per m <sup>3</sup> of air	<b>C19</b>													✓	✓	✓
Temperature class 155 (F), used acc. to 130 (B), coolant temperature 45 °C, derating approx. 4 % <sup>5)</sup>	<b>C22</b>													✓	✓	✓
Temperature class 155 (F), used acc. to 130 (B), coolant temperature 50 °C, derating approx. 8 % <sup>5)</sup>	<b>C23</b>													✓	✓	✓
Temperature class 155 (F), used acc. to 130 (B), coolant temperature 55 °C, derating approx. 13 % <sup>5)</sup>	<b>C24</b>													✓	✓	✓
Temperature class 155 (F), used acc. to 130 (B), coolant temperature 60 °C, derating approx. 18 % <sup>5)</sup>	<b>C25</b>													✓	✓	✓
Increased air humidity/temperature with 60 to 100 g water per m <sup>3</sup> of air	<b>C26</b>													✓	✓	✓
Temperature class 155 (F), used acc. to 130 (B), with a higher coolant temperature and/or site altitude	<b>Y50 •</b> and specified output, CT .. °C or SA .... m above sea level													✓	✓	✓
Temperature class 155 (F), used acc. to 155 (F), other requirements	<b>Y52 •</b> and specify output, CT .. °C or SA .... m above sea level													✓	✓	✓
<b>Colors and paint finish</b>																
Standard finish in RAL 7030 stone gray														□	□	□
Standard finish in other standard RAL colors: RAL 1002, 1013, 1015, 1019, 2003, 2004, 3000, 3007, 5007, 5009, 5010, 5012, 5015, 5017, 5018, 5019, 6011, 6019, 6021, 7000, 7001, 7004, 7011, 7016, 7022, 7031, 7032, 7033, 7035, 9001, 9002, 9005 Page 0/18	<b>Y53 •</b> and standard finish RAL ....													✓	✓	✓
Special finish in RAL 7030 stone gray	<b>K26</b>													✓	✓	✓

For legend, see Page 7/43, for footnotes, see Page 7/44.



# IEC Squirrel-Cage Motors

## Fan motors

### Special versions

Special versions	Additional identification code <b>-Z</b> with order code and plain text if required	Motor type frame size														
		56	63	71	80	90	100	112	132	160	180	200	225	250	280	315
<b>Self-ventilated motors in pole-changing version</b>																
<b>1LG4 (cast-iron)</b>																
<b>Colors and paint finish (continued)</b>																
Special finish in other standard RAL colors: RAL 1002, 1013, 1015, 1019, 2003, 2004, 3000, 3007, 5007, 5009, 5010, 5012, 5017, 5018, 5019, 6011, 6019, 6021, 7000, 7001, 7004, 7011, 7016, 7022, 7031, 7032, 7033, 7035, 9001, 9002, 9005 Page 0/18	<b>Y54 •</b> and special finish RAL .....										✓	✓	✓	✓	✓	✓
Special finish in special RAL colors: For RAL colors, see "Special finish in special RAL colors" on Page 0/19	<b>Y51 •</b> and special finish RAL .....										✓	✓	✓	✓	✓	✓
Offshore special finish	<b>M91</b>										✓	✓	✓	✓	✓	✓
Sea air resistant special finish	<b>M94</b>										O. R.	O. R.	O. R.	O. R.	O. R.	O. R.
Unpainted (only cast iron parts primed)	<b>K23</b>										○	○	○	○	○	○
Unpainted, only primed	<b>K24</b>										✓	✓	✓	✓	✓	✓
<b>Modular technology – Basic versions <sup>7)</sup></b>																
Mounting of separately driven fan <sup>8)</sup>	<b>G17</b>										✓	✓	✓	✓	✓	✓
Mounting of brake <sup>8) 9)</sup>	<b>G26</b>										✓	✓	✓	✓	✓	✓
Mounting of 1XP8 001-1 (HTL) rotary pulse encoder	<b>H57</b>										✓	✓	✓	✓	✓	✓
Mounting of 1XP8 001-2 (TTL) rotary pulse encoder	<b>H58</b>										✓	✓	✓	✓	✓	✓
<b>Modular technology – Combinations of basic versions <sup>7)</sup></b>																
Mounting of separately driven fan and 1XP8 001-1 rotary pulse encoder	<b>H61</b>										✓	✓	✓	✓	✓	✓
Mounting of brake and 1XP8 001-1 rotary pulse encoder <sup>9)</sup>	<b>H62</b>										✓	✓	✓	✓	✓	✓
Mounting of brake and separately driven fan <sup>8) 9)</sup>	<b>H63</b>										✓	✓	✓	✓	✓	✓
Mounting of brake, separately driven fan and 1XP8 001-1 rotary pulse encoder <sup>9)</sup>	<b>H64</b>										✓	✓	✓	✓	✓	✓
Mounting of separately driven fan and 1XP8 001-2 rotary pulse encoder	<b>H97</b>										✓	✓	✓	✓	✓	✓
Mounting of brake and 1XP8 001-2 rotary pulse encoder	<b>H98</b>										✓	✓	✓	✓	✓	✓
Mounting of brake, separately driven fan and 1XP8 001-2 rotary pulse encoder <sup>9)</sup>	<b>H99</b>										✓	✓	✓	✓	✓	✓
<b>Modular technology – Additional versions</b>																
Brake supply voltage 24 V DC	<b>C00</b>										✓	✓	✓	✓	✓	✓
Brake supply voltage 400 V AC	<b>C01</b>										✓	✓	✓	✓	✓	✓
Mechanical manual release of the brake with operating lever	<b>K82</b>										✓	✓	✓	✓	✓	✓
<b>Special technology <sup>7)</sup></b>																
Mounting of LL 861 900 220 rotary pulse encoder	<b>H70</b>										✓	✓	✓	✓	✓	✓
Mounting of HOG 9 D 1024 I rotary pulse encoder	<b>H72</b>										✓	✓	✓	✓	✓	✓
Mounting of HOG 10 D 1024 I rotary pulse encoder	<b>H73</b>										✓	✓	✓	✓	✓	✓
Prepared for mounting LL 861 900 220	<b>H78</b>										✓	✓	✓	✓	✓	✓
Prepared for mounting HOG 9 D 1024 I	<b>H79</b>										✓	✓	✓	✓	✓	✓
Prepared for mounting HOG 10 D 1024 I	<b>H80</b>										✓	✓	✓	✓	✓	✓

For legend, see Page 7/43, for footnotes, see Page 7/44.

# IEC Squirrel-Cage Motors

## Fan motors

### Special versions

Special versions	Additional identification code -Z with order code and plain text if required	Motor type frame size															
		56	63	71	80	90	100	112	132	160	180	200	225	250	280	315	
<b>Self-ventilated motors in pole-changing version</b>																	
<b>1LG4 (cast-iron)</b>																	
<b>Mechanical design and degrees of protection</b>																	
Drive-end seal for flange-mounting motors with oil resistance to 0.1 bar (not possible for IM V3 type of construction)	<b>K17</b>											✓	✓	✓	✓	✓	✓
IP65 degree of protection <sup>10)</sup>	<b>K50</b>											✓	✓	✓	✓	✓	✓
IP56 degree of protection (non-heavy-sea) <sup>11)</sup>	<b>K52</b>											✓	✓	✓	✓	✓	✓
Condensation water holes <sup>12)</sup>	<b>L12</b>											□	□	□	□	□	□
Non-rusting screws (externally)	<b>M27</b>											✓	✓	✓	✓	✓	✓
Earth brushes for converter-fed operation	<b>M44</b>											-	-	-	-	O. R.	O. R.
Mechanical protection for encoder <sup>13)</sup>	<b>M68</b>											✓	✓	✓	✓	✓	✓
<b>Coolant temperature and site altitude</b>																	
Coolant temperature -50 to +40 °C	<b>D02</b>											✓	✓	✓	✓	✓	✓
Coolant temperature -40 to +40 °C	<b>D03</b>											✓	✓	✓	✓	✓	✓
Coolant temperature -30 to +40 °C	<b>D04</b>											✓	✓	✓	✓	✓	✓
<b>Designs in accordance with standards and specifications</b>																	
Electrical according to NEMA MG1-12	<b>D30</b>											✓	✓	✓	✓	✓	✓
Design according to UL with "Recognition Mark" <sup>14)</sup>	<b>D31</b>											✓	✓	✓	✓	✓	✓
Canadian regulations (CSA) <sup>15)</sup>	<b>D40</b>											✓	✓	✓	✓	✓	✓
<b>Bearings and lubrication</b>																	
Measuring nipple for SPM shock pulse measurement for bearing inspection	<b>G50</b>											✓	✓	✓	✓	✓	✓
Bearing design for increased cantilever forces <sup>16)</sup>	<b>K20</b>											✓	✓	✓	✓	✓	✓
Special bearing for DE and NDE, bearing size 63	<b>K36</b>											✓	✓	✓	✓	□	□
Regreasing device	<b>K40</b>											✓	✓	✓	✓	□	□
Located bearing DE	<b>K94</b>											✓	✓	✓	✓	✓	✓
Located bearing NDE	<b>L04</b>											□	□	□	□	□	□
Insulated bearing cartridge	<b>L27</b>											-	-	✓	✓	✓	✓
<b>Balance and vibration quantity</b>																	
Vibration quantity A												□	□	□	□	□	□
Vibration quantity B	<b>K02</b>											✓	✓	✓	✓	✓	✓
Full key balancing	<b>L68</b>											✓	✓	✓	✓	✓	✓
Balancing without key	<b>M37</b>											✓	✓	✓	✓	✓	✓
<b>Shaft and rotor</b>																	
Concentricity of shaft extension, coaxiality and linear movement in accordance with DIN 42955 Tolerance R for flange-mounting motors <sup>17)</sup>	<b>K04</b>											✓	✓	✓	✓	✓	✓
Second standard shaft extension	<b>K16</b>											✓	✓	✓	✓	✓	✓
Shaft extension with standard dimensions without featherkey way	<b>K42</b>											✓	✓	✓	✓	✓	✓
Concentricity of shaft extension in accordance with DIN 42955 Tolerance R	<b>L39</b>											✓	✓	✓	✓	✓	✓
Non-standard cylindrical shaft extension <sup>18)</sup>	<b>Y55 •</b> and identification code											✓	✓	✓	✓	✓	✓

For legend, see Page 7/43, for footnotes, see Page 7/44.

# IEC Squirrel-Cage Motors

## Fan motors

### Special versions

Special versions	Additional identification code -Z with order code and plain text if required	Motor type frame size														
		56	63	71	80	90	100	112	132	160	180	200	225	250	280	315
<b>Self-ventilated motors in pole-changing version</b>																
<b>1LG4 (cast-iron)</b>																
<b>Heating and ventilation</b>																
Metal external fan <sup>19)</sup>	<b>K35</b>										✓	✓	✓	✓	✓	✓
Anti-condensation heaters for 230 V	<b>K45</b>										✓	✓	✓	✓	✓	✓
Anti-condensation heaters for 115 V	<b>K46</b>										✓	✓	✓	✓	✓	✓
Sheet metal fan cover	<b>L36</b>										✓	✓	✓	✓	✓	✓
Separately driven fan with non-standard voltage and/or frequency	<b>Y81</b> • and identification code										–	–	✓	✓	✓	✓
<b>Rating plate and extra rating plates</b>																
Second lubricating plate, supplied loose	<b>B06</b>										✓	✓	✓	✓	✓	✓
Second rating plate, loose	<b>K31</b>										✓	✓	✓	✓	✓	✓
Extra rating plate or rating plate with deviating rating plate data	<b>Y80</b> • and identification code										✓	✓	✓	✓	✓	✓
Extra rating plate with identification code	<b>Y82</b> • and identification code										✓	✓	✓	✓	✓	✓
Additional information on rating plate and on package label (maximum of 20 characters)	<b>Y84</b> • and identification code										✓	✓	✓	✓	✓	✓
<b>Packaging, safety notes, documentation and test certificates</b>																
Acceptance test certificate 3.1 according to EN 10204	<b>B02</b>										✓	✓	✓	✓	✓	✓
Operating instructions German/English enclosed in print	<b>B23</b>										✓	✓	✓	✓	✓	✓
Type test with heat run for horizontal motors, with acceptance	<b>F83</b>										✓	✓	✓	✓	✓	✓
Connected in star for dispatch	<b>M32</b>										✓	✓	✓	✓	✓	✓
Connected in delta for dispatch	<b>M33</b>										✓	✓	□	□	□	□

- Standard version
- Without additional charge
- This order code only determines the price of the version – Additional plain text is required.
- , R. Possible on request
- ✓ With additional charge
- Not possible

# IEC Squirrel-Cage Motors

## Fan motors

### Special versions

7

- 1) Evaluation with appropriate tripping unit (see Catalog LV 1) is recommended. For pole-changing motors with separate windings, the number of temperature sensors must be doubled (order code **A11**, price of **A12** or order code **A12**, price available on request).
- 2) PT 100 bearing monitoring only possible at drive end (DE).
- 3) In combination with the PTC thermistor option or anti-condensation heating option, please inquire before ordering.
- 4) Only possible in combination with order code **L44** to **L49** or length specification in plain text.
- 5) Only the 50 Hz data are specified on the rating plate.
- 6) Cannot be used for motors in UL version (order code **D31**) or CSA approval (order code **D40**). The grease lifetime specified in catalog part 0 "Introduction" refers to CT 40 °C. When the coolant temperature rises by 10 K, the grease lifetime or relubrication interval is halved.
- 7) A second shaft extension is not possible. Please inquire for mounted brakes. The order codes listed cannot be combined within the various technologies nor with each other within the same technology system. This applies for:
  - Modular technology
  - Basic versions of "Modular technology"
  - Combination of special versions "Special technology"
- 8) For 1LG4/1LG6 motors, order codes **G17**, **G26** and **H63** frame size 225 and above can also be combined with all rotary pulse encoders in the "Special technology" range.
- 9) The standard brake supply voltage is 230 V AC, 50/60 Hz. Other brake supply voltages are possible with order codes **C00** and **C01**.
- 10) Not possible in combination with rotary pulse encoder HOG 9 D 10241 (order code **H72**, **H79**) and / or brake 2LM8 (used for motors up to and including frame size 225, order code **G26**).
- 11) Not possible in combination with brake 2LM8 (used for motors up to and including frame size 225, order code **G26**).
- 12) Supplied with the condensation drainage holes sealed at the drive end DE and non-drive end NDE (IP55, IP56, IP65). If condensation drainage holes are required in motors of the IM B6, IM B7 or IM B8 type of construction (feet located on side or top), it is necessary to relocate the bearing plates at the drive end (DE) and non-drive end (NDE) so that the condensation drainage holes situated between the feet on delivery are underneath.
- 13) Not necessary when a rotary pulse encoder is combined with a separately driven fan, because in this case the rotary pulse encoder is installed under the fan cover.
- 14) Possible up to 600 V max. Order with voltage code **9** and order code for voltage and frequency. The rated voltage is indicated on the rating plate.
- 15) Order with voltage code **9** and order code for voltage and frequency. The rated voltage is indicated on the rating plate.
- 16) Bearings for increased cantilever forces at vibration quantity level B on request for 1LG4 motors. Not possible for 1LG4 motors in the combination "Concentricity of the shaft extension, coaxiality and linear movement in accordance with DIN 42955 Tolerance R for flange-mounting motors" – order code **K04**.
- 17) Can be combined with deep-groove bearings of series 60... 62... and 63... . Not possible with parallel roller bearings (e.g. bearings for increased cantilever forces, order code **K20**).
- 18) When motors are ordered that have a longer or shorter shaft extension than normal, the required position and length of the featherkey way must be specified in a sketch. It must be ensured that only featherkeys in accordance with DIN 6885, Form A are permitted to be used. The featherkey way is positioned centrally on the shaft extension. The length is defined by the manufacturer normatively. Not valid for: Conical shafts, non-standard threaded journals, non-standard shaft tolerances, friction welded journals, extremely "thin" shafts, special geometry dimensions (e.g. square journals), hollow shafts. Valid for non-standard shaft extensions DE or NDE. The featherkeys are supplied in every case. For order codes **Y55** and **K16**:
  - Dimensions D and DA ≤ internal diameter of roller bearing (see dimension tables under "Dimensions")
  - Dimensions E and EA ≤ 2 x length E (normal) of the shaft extension
 For an explanation of the order codes, see catalog part 0 "Introduction".
- 19) For 1LA5/6/7/9 motors and 1LG with metal external fan, converter-fed operation is permitted.

# IEC Squirrel-Cage Motors

## Fan motors

### Special versions

Options or order codes (supplement **-Z** is required)

Special versions	Additional identification code <b>-Z</b> with order code and plain text if required	Motor type frame size														
		56	63	71	80	90	100	112	132	160	180	200	225	250	280	315
<b>Forced-air cooled motors without external fan and fan cover</b>																
			<b>1PP7 (aluminum)</b>								<b>1PP5 (aluminum)</b>					
<b>Motor protection</b>																
Motor protection with PTC thermistors with 3 embedded temperature sensors for tripping <sup>1)</sup>	<b>A11</b>		✓	✓	✓	✓	✓	✓	✓	✓	✓	✓	✓	✓	✓	✓
Motor protection with PTC thermistors with 6 embedded temperature sensors for tripping and alarm <sup>1)</sup>	<b>A12</b>		✓	✓	✓	✓	✓	✓	✓	✓	✓	✓	✓	✓	✓	✓
Motor temperature detection with embedded temperature sensor KTY 84-130 <sup>1)</sup>	<b>A23</b>		✓	✓	✓	✓	✓	✓	✓	✓	✓	✓	✓	✓	✓	✓
Motor temperature detection with embedded temperature sensors 2 x KTY 84-130 <sup>1)</sup>	<b>A25</b>		✓	✓	✓	✓	✓	✓	✓	✓	✓	✓	✓	✓	✓	✓
Temperature detectors for tripping <sup>1)</sup>	<b>A31</b>		✓	✓	✓	✓	✓	✓	✓	✓	✓	✓	✓	✓	✓	✓
Installation of 3 PT 100 resistance thermometers <sup>1)</sup>	<b>A60</b>		–	–	–	–	–	✓	✓	✓	✓	✓	✓	✓	✓	✓
<b>Motor connection and connection box</b>																
ECOFAST motor plug Han-Drive 10e for 230 VΔ/400 VY <sup>2)</sup>	<b>G55</b>		✓	✓	✓	✓	✓	✓	✓	–	–	–	–	–	–	–
ECOFAST motor plug EMC Han-Drive 10e for 230 VΔ/400 VY <sup>3)</sup>	<b>G56</b>		✓	✓	✓	✓	✓	✓	✓	–	–	–	–	–	–	–
Connection box on RHS	<b>K09</b>		–	–	✓	✓	✓	✓	✓	✓	✓	✓	✓	✓	✓	✓
Connection box on LHS	<b>K10</b>		–	–	✓	✓	✓	✓	✓	✓	✓	✓	✓	✓	✓	✓
One cable gland, metal	<b>K54</b>		✓	✓	✓	✓	✓	✓	✓	✓	✓	✓	✓	✓	✓	✓
Rotation of the connection box through 90°, entry from DE	<b>K83</b>		✓	✓	✓	✓	✓	✓	✓	✓	✓	✓	✓	✓	✓	✓
Rotation of the connection box through 90°, entry from NDE	<b>K84</b>		✓	✓	✓	✓	✓	✓	✓	✓	✓	✓	✓	✓	✓	✓
Rotation of connection box through 180°	<b>K85</b>		✓	✓	✓	✓	✓	○	○	○	○	✓	✓	✓	✓	✓
Next larger connection box	<b>L00</b>		–	–	–	–	–	–	–	–	–	✓	✓	✓	✓	✓
External earthing	<b>L13</b>		✓	✓	✓	✓	✓	✓	✓	✓	✓	✓	✓	✓	✓	✓
3 cables protruding, 0.5 m long <sup>4)</sup>	<b>L44</b>		✓	✓	✓	✓	✓	✓	✓	✓	✓	✓	✓	O. R.	O. R.	O. R.
3 cables protruding, 1.5 m long <sup>4)</sup>	<b>L45</b>		✓	✓	✓	✓	✓	✓	✓	✓	✓	✓	✓	O. R.	O. R.	O. R.
6 cables protruding, 0.5 m long <sup>4)</sup>	<b>L47</b>		✓	✓	✓	✓	✓	✓	✓	✓	✓	✓	✓	O. R.	O. R.	O. R.
6 cables protruding, 1.5 m long <sup>4)</sup>	<b>L48</b>		✓	✓	✓	✓	✓	✓	✓	✓	✓	✓	✓	✓	✓	✓
Connection box on NDE	<b>M64</b>		✓	✓	✓	✓	✓	✓	✓	✓	✓	✓	✓	✓	✓	✓
Terminal strip for main and auxiliary terminals	<b>M69</b>		✓	✓	✓	✓	–	–	–	–	–	–	–	–	–	–
<b>Windings and insulation</b>																
Temperature class 155 (F), used acc. to 155 (F), with service factor (SF)	<b>C11</b>		✓	✓	✓	✓	✓	✓	✓	✓	✓	✓	✓	✓	✓	✓
Temperature class 155 (F), used acc. to 155 (F), with increased output	<b>C12</b>		✓	✓	✓	✓	✓	✓	✓	✓	✓	✓	✓	✓	✓	✓
Temperature class 155 (F), used acc. to 155 (F), with increased coolant temperature	<b>C13</b>		✓	✓	✓	✓	✓	✓	✓	✓	✓	✓	✓	✓	✓	✓
Temperature class 180 (H) at rated output and max. CT 60 °C <sup>5)</sup>	<b>C18</b>		✓	✓	✓	✓	✓	✓	✓	✓	✓	✓	✓	✓	✓	✓

For legend and footnotes, see Page 7/48.

# IEC Squirrel-Cage Motors

## Fan motors

### Special versions

Special versions	Additional identification code <b>-Z</b> with order code and plain text if required	Motor type frame size														
		56	63	71	80	90	100	112	132	160	180	200	225	250	280	315
<b>Forced-air cooled motors without external fan and fan cover</b>																
			<b>1PP7 (aluminum)</b>						<b>1PP5 (aluminum)</b>							
<b>Windings and insulation (continued)</b>																
Increased air humidity/temperature with 30 to 60 g water per m <sup>3</sup> of air	<b>C19</b>		✓	✓	✓	✓	✓	✓	✓	✓	✓	✓	✓	✓	✓	✓
Temperature class 155 (F), used acc. to 130 (B), coolant temperature 45 °C, derating approx. 4 %	<b>C22</b>		✓	✓	✓	✓	✓	✓	✓	✓	✓	✓	✓	✓	✓	✓
Temperature class 155 (F), used acc. to 130 (B), coolant temperature 50 °C, derating approx. 8 %	<b>C23</b>		✓	✓	✓	✓	✓	✓	✓	✓	✓	✓	✓	✓	✓	✓
Temperature class 155 (F), used acc. to 130 (B), coolant temperature 55 °C, derating approx. 13 %	<b>C24</b>		✓	✓	✓	✓	✓	✓	✓	✓	✓	✓	✓	✓	✓	✓
Temperature class 155 (F), used acc. to 130 (B), coolant temperature 60 °C, derating approx. 18 %	<b>C25</b>		✓	✓	✓	✓	✓	✓	✓	✓	✓	✓	✓	✓	✓	✓
Increased air humidity/temperature with 60 to 100 g water per m <sup>3</sup> of air	<b>C26</b>		✓	✓	✓	✓	✓	✓	✓	✓	✓	✓	✓	✓	✓	✓
Temperature class 155 (F), used acc. to 130 (B), with a higher coolant temperature and/or site altitude	<b>Y50 •</b> and specified output, CT... °C or SA .... m above sea level		✓	✓	✓	✓	✓	✓	✓	✓	✓	✓	✓	✓	✓	✓
Temperature class 155 (F), used acc. to 155 (F), other requirements	<b>Y52 •</b> and specified output, CT... °C or SA .... m above sea level		✓	✓	✓	✓	✓	✓	✓	✓	✓	✓	✓	✓	✓	✓
<b>Colors and paint finish</b>																
Special finish in RAL 7030 stone gray			□	□	□	□	□	□	□	□	□	□	□	□	□	□
Special finish in other standard RAL colors: RAL 1002, 1013, 1015, 1019, 2003, 2004, 3000, 3007, 5007, 5009, 5010, 5012, 5017, 5018, 5019, 6011, 6019, 6021, 7000, 7001, 7004, 7011, 7016, 7022, 7031, 7032, 7033, 7035, 9001, 9002, 9005 Page 0/18	<b>Y54 •</b> and special finish RAL ....		✓	✓	✓	✓	✓	✓	✓	✓	✓	✓	✓	✓	✓	✓
Special finish in special RAL colors: For RAL colors, see "Special finish in special RAL colors" on Page 0/19	<b>Y51 •</b> and special finish RAL ....		✓	✓	✓	✓	✓	✓	✓	✓	✓	✓	✓	✓	✓	✓
Sea air resistant special finish	<b>M94</b>		O. R.	O. R.	O. R.	O. R.	O. R.	O. R.	O. R.	O. R.	O. R.	O. R.	O. R.	O. R.	O. R.	O. R.
Unpainted (only cast iron parts primed)	<b>K23</b>		○	○	○	○	○	○	○	○	○	○	○	○	○	○
Unpainted, only primed	<b>K24</b>		✓	✓	✓	✓	✓	✓	✓	✓	✓	✓	✓	✓	✓	✓
<b>Mechanical design and degrees of protection</b>																
Drive-end seal for flange-mounting motors with oil resistance to 0.1 bar Not possible for IM V3 type of construction	<b>K17</b>		✓	✓	✓	✓	✓	✓	✓	✓	✓	✓	✓	✓	✓	✓
With two additional eyebolts for IM V1/IM V3	<b>K32</b>		–	–	–	–	–	–	–	–	–	–	–	–	✓	✓
IP65 degree of protection	<b>K50</b>		✓	✓	✓	✓	✓	✓	✓	✓	✓	✓	✓	✓	✓	✓
IP56 degree of protection (non-heavy-sea)	<b>K52</b>		✓	✓	✓	✓	✓	✓	✓	✓	✓	✓	✓	✓	✓	✓
Vibration-proof version	<b>L03</b>		✓	✓	✓	✓	✓	✓	✓	✓	✓	✓	✓	✓	✓	✓
Condensation drainage holes <sup>6)</sup>	<b>L12</b>		✓	✓	✓	✓	✓	✓	✓	✓	✓	✓	✓	✓	✓	✓
Non-rusting screws (externally)	<b>M27</b>		✓	✓	✓	✓	✓	✓	✓	✓	✓	✓	✓	✓	✓	✓

For legend and footnotes, see Page 7/48.

# IEC Squirrel-Cage Motors

## Fan motors

### Special versions

Special versions	Additional identification code <b>-Z</b> with order code and plain text if required	Motor type frame size														
		56	63	71	80	90	100	112	132	160	180	200	225	250	280	315
<b>Forced-air cooled motors without external fan and fan cover</b>																
		<b>1PP7 (aluminum)</b>						<b>1PP5 (aluminum)</b>								
<b>Coolant temperature and site altitude</b>																
Coolant temperature -40 to +40 °C	<b>D03</b>	✓	✓	✓	✓	✓	✓	✓	✓	✓	✓	✓	✓	✓	✓	✓
Coolant temperature -30 to +40 °C	<b>D04</b>	✓	✓	✓	✓	✓	✓	✓	✓	✓	✓	✓	✓	✓	✓	✓
<b>Designs in accordance with standards and specifications</b>																
Design according to UL with "Recognition Mark" <sup>7)</sup>	<b>D31</b>	✓	✓	✓	✓	✓	✓	✓	✓	✓	✓	✓	✓	✓	✓	✓
Canadian regulations (CSA) <sup>8)</sup>	<b>D40</b>	✓	✓	✓	✓	✓	✓	✓	✓	✓	✓	✓	✓	✓	✓	✓
PSE Mark Japan <sup>9)</sup>	<b>D46</b>	✓	✓	✓	✓	✓	✓	✓	✓	✓	-	-	-	-	-	-
<b>Bearings and lubrication</b>																
Measuring nipple for SPM shock pulse measurement for bearing inspection	<b>G50</b>	-	-	-	-	✓	✓	✓	✓	✓	✓	✓	✓	✓	✓	✓
Bearing design for increased cantilever forces	<b>K20</b>	-	-	-	-	✓	✓	✓	✓	✓	✓	✓	✓	✓	✓	✓
Regreasing device	<b>K40</b>	-	-	-	-	✓	✓	✓	✓	✓	✓	✓	✓	✓	✓	✓
Located bearing DE	<b>K94</b>	✓	✓	✓	✓	✓	✓	✓	✓	✓	✓	✓	✓	✓	✓	✓
Located bearing NDE	<b>L04</b>	✓	✓	✓	✓	✓	✓	✓	✓	✓	-	-	-	-	-	-
<b>Balance and vibration quantity</b>																
Vibration quantity A		□	□	□	□	□	□	□	□	□	□	□	□	□	□	□
Vibration quantity B	<b>K02</b>	✓	✓	✓	✓	✓	✓	✓	✓	✓	✓	✓	✓	✓	✓	✓
Full key balancing	<b>L68</b>	✓	✓	✓	✓	✓	✓	✓	✓	✓	✓	✓	✓	✓	✓	✓
Balancing without key	<b>M37</b>	✓	✓	✓	✓	✓	✓	✓	✓	✓	✓	✓	✓	✓	✓	✓
<b>Shaft and rotor</b>																
Concentricity of shaft extension, coaxiality and linear movement in accordance with DIN 42955 Tolerance R for flange-mounting motors <sup>10)</sup>	<b>K04</b>	✓	✓	✓	✓	✓	✓	✓	✓	✓	✓	✓	✓	✓	✓	✓
Second standard shaft extension	<b>K16</b>	✓	✓	✓	✓	✓	✓	✓	✓	✓	✓	✓	✓	✓	✓	✓
Shaft extension with standard dimensions without featherkey way	<b>K42</b>	✓	✓	✓	✓	✓	✓	✓	✓	✓	✓	✓	✓	✓	✓	✓
Concentricity of shaft extension in accordance with DIN 42955 Tolerance R	<b>L39</b>	✓	✓	✓	✓	✓	✓	✓	✓	✓	✓	✓	✓	✓	✓	✓
Standard shaft made of non-rusting steel	<b>M65</b>	-	-	✓	✓	✓	✓	✓	✓	✓	✓	✓	✓	✓	✓	✓
Non-standard cylindrical shaft extension <sup>11)</sup>	<b>Y55 •</b> and identification code	✓	✓	✓	✓	✓	✓	✓	✓	✓	✓	✓	✓	✓	✓	✓
<b>Heating and ventilation</b>																
Anti-condensation heaters for 230 V	<b>K45</b>	✓	✓	✓	✓	✓	✓	✓	✓	✓	✓	✓	✓	✓	✓	✓
Anti-condensation heaters for 115 V	<b>K46</b>	✓	✓	✓	✓	✓	✓	✓	✓	✓	✓	✓	✓	✓	✓	✓
<b>Rating plate and extra rating plates</b>																
Second lubricating plate, supplied loose	<b>B06</b>	-	-	-	-	✓	✓	✓	✓	✓	✓	✓	✓	✓	✓	✓
Second rating plate, loose	<b>K31</b>	✓	✓	✓	✓	✓	✓	✓	✓	✓	✓	✓	✓	✓	✓	✓
Extra rating plate or rating plate with deviating rating plate data	<b>Y80 •</b> and identification code	✓	✓	✓	✓	✓	✓	✓	✓	✓	✓	✓	✓	✓	✓	✓
Extra rating plate with identification code	<b>Y82 •</b> and identification code	✓	✓	✓	✓	✓	✓	✓	✓	✓	✓	✓	✓	✓	✓	✓
Additional information on rating plate and on package label (maximum of 20 characters)	<b>Y84 •</b> and identification code	✓	✓	✓	✓	✓	✓	✓	✓	✓	✓	✓	✓	✓	✓	✓

For legend and footnotes, see Page 7/48.

# IEC Squirrel-Cage Motors

## Fan motors

### Special versions

Special versions	Additional identification code <b>-Z</b> with order code and plain text if required	Motor type frame size															
		56	63	71	80	90	100	112	132	160	180	200	225	250	280	315	
<b>Forced-air cooled motors without external fan and fan cover</b>																	
		<b>1PP7 (aluminum)</b>										<b>1PP5 (aluminum)</b>					
<b>Packaging, safety notes, documentation and test certificates</b>																	
Without safety and commissioning note. Customer's declaration of renouncement required.	<b>B00</b>	–	○	○	○	○	○	○	○	○	○	○	○	○	○	○	○
With one safety and startup guide per box pallet	<b>B01</b>	–	○	○	○	○	○	○	○	○	○	○	○	○	○	○	○
Acceptance test certificate 3.1 according to EN 10204	<b>B02</b>	✓	✓	✓	✓	✓	✓	✓	✓	✓	✓	✓	✓	✓	✓	✓	✓
Operating instructions German/English enclosed in print	<b>B23</b>	✓	✓	✓	✓	✓	✓	✓	✓	✓	✓	✓	✓	✓	✓	✓	✓
Type test with heat run for vertical motors, with acceptance	<b>F83</b>	✓	✓	✓	✓	✓	✓	✓	✓	✓	✓	✓	✓	✓	✓	✓	✓
Wire-lattice pallet	<b>L99</b>	○	○	○	○	○	○	○	○	○	○	○	○	○	○	○	○
Connected in star for dispatch	<b>M32</b>	✓	✓	✓	✓	✓	✓	✓	✓	✓	✓	✓	✓	✓	✓	✓	✓
Connected in delta for dispatch	<b>M33</b>	✓	✓	✓	✓	✓	✓	✓	✓	✓	✓	✓	✓	✓	✓	✓	✓

- Standard version
- Without additional charge
- This order code only determines the price of the version – Additional plain text is required.
- , R. Possible on request
- ✓ With additional charge
- Not possible

7

- 1) Evaluation with appropriate tripping unit (see Catalog LV 1) is recommended.
- 2) Only one sensor (temperature sensor or PTC thermistor) can be connected. Only possibilities are voltage code **1** with voltage of 230 VΔ/400 VY and special voltage with voltage code **9** and order code **L1U** (400 VΔ). The following order codes cannot be used in combination with the ECOFAST plugs, order code **G55: A12, C02, C18, D31, D40, G50, H15, H17, H62, H63, H64, H90, H91, H92, H93, H94, H95, H98, H99, K04, K15, K16, K34, K35, K40, K45, K46, K52, K54, K82, L03, L44, L45, L47, L48, L49, L51, L52**.
- 3) Not possible for pole-changing motors. Only one sensor (temperature sensor or PTC thermistor) can be connected. Only possibilities are voltage code **1** with voltage of 230 VΔ/400 VY and special voltage with voltage code **9** and order code **L1U** (400 VΔ). The following order codes cannot be used in combination with the ECOFAST plugs, order code **G56: A12, A23, A31, C00, C18, D31, D40, G50, H15, H17, H90, H91, H92, H93, H94, H95, K04, K15, K16, K34, K35, K40, K45, K46, K52, K54, K82, L03, L44, L45, L47, L48, L49, L51, L52**.
- 4) In combination with the PTC thermistor option or anti-condensation heating option, please inquire before ordering.
- 5) Cannot be used for motors in UL version (order code **D31**). Cannot be used for motors according to CSA approval (order code **D40**) for motor series 1PP7 frame size 180 to 200. The grease lifetime specified in catalog part 0 "Introduction" refers to CT 40 °C. When the coolant temperature rises by 10 K, the grease lifetime or relubrication interval is halved.
- 6) Supplied with the condensation drainage holes sealed at the drive end DE and non-drive end NDE for IP55, IP56 and IP65 degrees of protection. If condensation drainage holes are required in motors of the IM B6, IM B7 or IM B8 type of construction (feet located on side or top), it is necessary to relocate the bearing plates at the drive end (DE) and non-drive end (NDE) so that the condensation drainage holes situated between the feet on delivery are underneath.
- 7) Possible up to 600 V max. The rated voltage is indicated on the rating plate without voltage range.
- 8) The rated voltage is indicated on the rating plate without voltage range.
- 9) "Small power motors" with a rated output of up to 3 kW which are exported to Japan must bear the marking.
- 10) Can be combined with deep-groove bearings of series 60... 62... and 63... Not possible with parallel roller bearings (e.g. bearings for increased cantilever forces, order code **K20**) brake or encoder mounting.
- 11) When motors are ordered that have a longer or shorter shaft extension than normal, the required position and length of the featherkey way must be specified in a sketch. It must be ensured that only featherkeys in accordance with DIN 6885, Form A are permitted to be used. The featherkey way is positioned centrally on the shaft extension. The length is defined by the manufacturer normatively. Not valid for: Conical shafts, non-standard threaded journals, non-standard shaft tolerances, friction welded journals, extremely "thin" shafts, special geometry dimensions (e.g. square journals), hollow shafts. Valid for non-standard shaft extensions DE or NDE. The featherkeys are supplied in every case. For order codes **Y55** and **K16**:
  - Dimensions D and DA ≤ internal diameter of roller bearing (see dimension tables under "Dimensions")
  - Dimensions E and EA ≤ 2 x length E (normal) of the shaft extension
 For an explanation of the order codes, see catalog part 0 "Introduction".



# IEC Squirrel-Cage Motors

## Fan motors

### Special versions

Options or order codes (supplement **-Z** is required)

Special versions	Additional identification code <b>-Z</b> with order code and plain text if required	Motor type frame size															
		56	63	71	80	90	100	112	132	160	180	200	225	250	280	315	
<b>Forced-air cooled motors without external fan and fan cover</b>																	
<b>1PP4 (cast-iron)</b>																	
<b>Motor protection</b>																	
Motor protection with PTC thermistors with 3 embedded temperature sensors for tripping <sup>1)</sup>	<b>A11</b>											✓	✓	✓	✓	✓	✓
Motor protection with PTC thermistors with 6 embedded temperature sensors for tripping and alarm <sup>1)</sup>	<b>A12</b>											✓	✓	✓	✓	✓	✓
Motor temperature detection with embedded temperature sensor KTY 84-130 <sup>1)</sup>	<b>A23</b>											✓	✓	✓	✓	✓	✓
Motor temperature detection with embedded temperature sensors 2 x KTY 84-130 <sup>1)</sup>	<b>A25</b>											✓	✓	✓	✓	✓	✓
Temperature detectors for tripping	<b>A31</b>											✓	✓	✓	✓	✓	✓
Installation of 3 PT 100 resistance thermometers <sup>1)</sup>	<b>A60</b>											✓	✓	✓	✓	✓	✓
Installation of 6 PT 100 resistance thermometers in stator winding <sup>1)</sup>	<b>A61</b>											✓	✓	✓	✓	✓	✓
Installation of 2 PT 100 screw-in resistance thermometers (basic circuit) for rolling-contact bearings <sup>1)</sup>	<b>A72</b>											✓	✓	✓	✓	✓	✓
Installation of 2 PT 100 screw-in resistance thermometers (3-wire circuit) for rolling-contact bearings <sup>1)</sup>	<b>A78</b>											✓	✓	✓	✓	✓	✓
Installation of 2 PT 100 double screw-in resistance thermometers (3-wire circuit) for rolling-contact bearings <sup>1)</sup>	<b>A80</b>											✓	✓	✓	✓	✓	✓
<b>Motor connection and connection box</b>																	
Two-part plate on connection box	<b>K06</b>											–	✓	✓	✓	✓	✓
Connection box on RHS	<b>K09</b>											✓	✓	✓	✓	✓	✓
Connection box on LHS	<b>K10</b>											✓	✓	✓	✓	✓	✓
Connection box on top, feet screwed on	<b>K11</b>											✓	✓	✓	✓	✓	✓
One cable gland, metal	<b>K54</b>											✓	✓	✓	✓	✓	✓
Cable gland, maximum configuration	<b>K55</b>											✓	✓	✓	✓	✓	✓
Rotation of the connection box through 90°, entry from DE	<b>K83</b>											✓	✓	✓	✓	✓	✓
Rotation of the connection box through 90°, entry from NDE	<b>K84</b>											✓	✓	✓	✓	✓	✓
Rotation of connection box through 180°	<b>K85</b>											✓	✓	✓	✓	✓	✓
Next larger connection box	<b>L00</b>											✓	✓	✓	✓	✓	✓
External earthing	<b>L13</b>											□	□	□	□	□	□
6 cables protruding, 1.5 m long <sup>2)</sup>	<b>L48</b>											✓	✓	✓	O. R.	O. R.	O. R.
6 cables protruding, 3 m long <sup>2)</sup>	<b>L49</b>											✓	✓	✓	O. R.	O. R.	O. R.
Protruding cable ends – right side <sup>2) 3)</sup>	<b>L51</b>											O. R.	O. R.	O. R.	O. R.	O. R.	O. R.
Protruding cable ends – left side <sup>2) 3)</sup>	<b>L52</b>											O. R.	O. R.	O. R.	O. R.	O. R.	O. R.
Auxiliary connection box 1XB3 020	<b>L97</b>											✓	✓	✓	✓	✓	✓
Stud terminal for cable connection, accessories pack (3 items)	<b>M46</b>											–	–	–	✓	✓	✓
Saddle terminal for connection without cable lug, accessories pack (6 items)	<b>M47</b>											–	–	–	✓	✓	✓

For legend and footnotes, see Page 7/52.

# IEC Squirrel-Cage Motors

## Fan motors

### Special versions

Special versions	Additional identification code <b>-Z</b> with order code and plain text if required	Motor type frame size														
		56	63	71	80	90	100	112	132	160	180	200	225	250	280	315
<b>Forced-air cooled motors without external fan and fan cover</b>																
<b>Windings and insulation</b>																
<b>1PP4 (cast-iron)</b>																
Temperature class 155 (F), used acc. to 155 (F), with service factor (SF)	<b>C11</b>										✓	✓	✓	✓	✓	✓
Temperature class 155 (F), used acc. to 155 (F), with increased output <sup>4)</sup>	<b>C12</b>										✓	✓	✓	✓	✓	✓
Temperature class 155 (F), used acc. to 155 (F), with increased coolant temperature	<b>C13</b>										✓	✓	✓	✓	✓	✓
Temperature class 180 (H) at rated output and max. CT 60 °C <sup>5)</sup>	<b>C18</b>										✓	✓	✓	✓	✓	✓
Increased air humidity/temperature with 30 to 60 g water per m <sup>3</sup> of air	<b>C19</b>										✓	✓	✓	✓	✓	✓
Temperature class 155 (F), used acc. to 130 (B), coolant temperature 45 °C, derating approx. 4 %	<b>C22</b>										✓	✓	✓	✓	✓	✓
Temperature class 155 (F), used acc. to 130 (B), coolant temperature 50 °C, derating approx. 8 %	<b>C23</b>										✓	✓	✓	✓	✓	✓
Temperature class 155 (F), used acc. to 130 (B), coolant temperature 55 °C, derating approx. 13 %	<b>C24</b>										✓	✓	✓	✓	✓	✓
Temperature class 155 (F), used acc. to 130 (B), coolant temperature 60 °C, derating approx. 18 %	<b>C25</b>										✓	✓	✓	✓	✓	✓
Increased air humidity/temperature with 60 to 100 g water per m <sup>3</sup> of air	<b>C26</b>										✓	✓	✓	✓	✓	✓
Temperature class 155 (F), used acc. to 130 (B), with a higher coolant temperature and/or site altitude	<b>Y50 •</b> and specified output, CT ... °C or SA ... m above sea level										✓	✓	✓	✓	✓	✓
Temperature class 155 (F), used acc. to 155 (F), other requirements	<b>Y52 •</b> and specified output, CT ... °C or SA ... m above sea level										✓	✓	✓	✓	✓	✓
<b>Colors and paint finish</b>																
Standard finish in RAL 7030 stone gray											□	□	□	□	□	□
Standard finish in other standard RAL colors: RAL 1002, 1013, 1015, 1019, 2003, 2004, 3000, 3007, 5007, 5009, 5010, 5012, 5015, 5017, 5018, 5019, 6011, 6019, 6021, 7000, 7001, 7004, 7011, 7016, 7022, 7031, 7032, 7033, 7035, 9001, 9002, 9005 Page 0/18	<b>Y53 •</b> and standard finish RAL ....										✓	✓	✓	✓	✓	✓
Special finish in RAL 7030 stone gray	<b>K26</b>										✓	✓	✓	✓	✓	✓
Special finish in other standard RAL colors: RAL 1002, 1013, 1015, 1019, 2003, 2004, 3000, 3007, 5007, 5009, 5010, 5012, 5015, 5017, 5018, 5019, 6011, 6019, 6021, 7000, 7001, 7004, 7011, 7016, 7022, 7031, 7032, 7033, 7035, 9001, 9002, 9005 Page 0/18	<b>Y54 •</b> and special finish RAL ....										✓	✓	✓	✓	✓	✓

For legend and footnotes, see Page 7/52.

# IEC Squirrel-Cage Motors

## Fan motors

### Special versions

Special versions	Additional identification code <b>-Z</b> with order code and plain text if required	Motor type frame size															
		56	63	71	80	90	100	112	132	160	180	200	225	250	280	315	
<b>Forced-air cooled motors without external fan and fan cover</b>																	
<b>Colors and paint finish (continued)</b>																	
Special finish in special RAL colors: For RAL colors, see "Special finish in special RAL colors" on Page 0/19	<b>Y51 •</b> and special finish RAL ....											✓	✓	✓	✓	✓	✓
Offshore special finish	<b>M91</b>											✓	✓	✓	✓	✓	✓
Sea air resistant special finish	<b>M94</b>											O. R.	O. R.	O. R.	O. R.	O. R.	O. R.
Unpainted (only cast iron parts primed)	<b>K23</b>											○	○	○	○	○	○
Unpainted, only primed	<b>K24</b>											✓	✓	✓	✓	✓	✓
<b>Mechanical design and degrees of protection</b>																	
Drive-end seal for flange-mounting motors with oil resistance to 0.1 bar (Not possible for type of construction IM V3) <sup>6)</sup>	<b>K17</b>											✓	✓	✓	✓	✓	✓
IP65 degree of protection	<b>K50</b>											✓	✓	✓	✓	✓	✓
IP56 degree of protection (non-heavy-sea)	<b>K52</b>											✓	✓	✓	✓	✓	✓
Non-rusting screws (externally)	<b>M27</b>											✓	✓	✓	✓	✓	✓
<b>Coolant temperature and site altitude</b>																	
Coolant temperature -50 to +40 °C	<b>D02</b>											✓	✓	✓	✓	✓	✓
Coolant temperature -40 to +40 °C	<b>D03</b>											✓	✓	✓	✓	✓	✓
Coolant temperature -30 to +40 °C	<b>D04</b>											✓	✓	✓	✓	✓	✓
<b>Designs in accordance with standards and specifications</b>																	
Design according to UL with "Recognition Mark" <sup>7)</sup>	<b>D31</b>											✓	✓	✓	✓	✓	✓
Canadian regulations (CSA) <sup>8)</sup>	<b>D40</b>											✓	✓	✓	✓	✓	✓
<b>Bearings and lubrication</b>																	
Measuring nipple for SPM shock pulse measurement for bearing inspection	<b>G50</b>											✓	✓	✓	✓	✓	✓
Bearing design for increased cantilever forces <sup>9)</sup>	<b>K20</b>											✓	✓	✓	✓	✓	✓
Special bearing for DE and NDE, bearing size 63	<b>K36</b>											✓	✓	✓	✓	✓ <sup>10)</sup>	✓ <sup>10)</sup>
Regreasing device	<b>K40</b>											✓	✓	✓	✓	–	–
Located bearing DE	<b>K94</b>											✓	✓	✓	✓	✓	✓
Located bearing NDE	<b>L04</b>											□	□	□	□	□	□
Insulated bearing cartridge	<b>L27</b>											–	–	✓	✓	✓	✓
<b>Balance and vibration quantity</b>																	
Vibration quantity A												□	□	□	□	□	□
Vibration quantity B	<b>K02</b>											✓	✓	✓	✓	✓	✓
Full key balancing	<b>L68</b>											✓	✓	✓	✓	✓	✓
Balancing without key	<b>M37</b>											✓	✓	✓	✓	✓	✓
<b>Shaft and rotor</b>																	
Concentricity of shaft extension, coaxiality and linear movement in accordance with DIN 42955 Tolerance R for flange-mounting motors <sup>11)</sup>	<b>K04</b>											✓	✓	✓	✓	✓	✓
Second standard shaft extension <sup>12)</sup>	<b>K16</b>											✓	✓	✓	✓	✓	✓
Shaft extension with standard dimensions without featherkey way	<b>K42</b>											✓	✓	✓	✓	✓	✓
Concentricity of shaft extension in accordance with DIN 42955 Tolerance R	<b>L39</b>											✓	✓	✓	✓	✓	✓
Non-standard cylindrical shaft extension <sup>13)</sup>	<b>Y55 •</b> and identification code											✓	✓	✓	✓	✓	✓

For legend and footnotes, see Page 7/52.

# IEC Squirrel-Cage Motors

## Fan motors

### Special versions

Special versions	Additional identification code <b>-Z</b> with order code and plain text if required	Motor type frame size															
		56	63	71	80	90	100	112	132	160	180	200	225	250	280	315	
<b>Forced-air cooled motors without external fan and fan cover</b>																	
<b>1PP4 (cast-iron)</b>																	
<b>Heating and ventilation</b>																	
Anti-condensation heaters for 230 V	<b>K45</b>											✓	✓	✓	✓	✓	✓
Anti-condensation heaters for 115 V	<b>K46</b>											✓	✓	✓	✓	✓	✓
<b>Rating plate and extra rating plates</b>																	
Second lubricating plate, supplied loose	<b>B06</b>											✓	✓	✓	✓	✓	✓
Second rating plate, loose	<b>K31</b>											✓	✓	✓	✓	✓	✓
Extra rating plate or rating plate with deviating rating plate data	<b>Y80 •</b> and identification code											✓	✓	✓	✓	✓	✓
Extra rating plate with identification code	<b>Y82 •</b> and identification code											✓	✓	✓	✓	✓	✓
Additional information on rating plate and on package label (maximum of 20 characters)	<b>Y84 •</b> and identification code											✓	✓	✓	✓	✓	✓
<b>Packaging, safety notes, documentation and test certificates</b>																	
Acceptance test certificate 3.1 according to EN 10204	<b>B02</b>											✓	✓	✓	✓	✓	✓
Type test with heat run for vertical motors, with acceptance	<b>F83</b>											✓	✓	✓	✓	✓	✓
Connected in star for dispatch	<b>M32</b>											✓	✓	✓	✓	✓	✓
Connected in delta for dispatch	<b>M33</b>											✓	✓	□	□	□	□

- Standard version
- Without additional charge
- This order code only determines the price of the version – Additional plain text is required.
- R. Possible on request
- ✓ With additional charge
- Not possible

7

- 1) Evaluation with appropriate tripping unit (see Catalog LV 1) recommended.
- 2) In combination with the PTC thermistor option or anti-condensation heating option, please inquire before ordering.
- 3) Possible in combination with order code **L44** to **L49** or length specification in plain text.
- 4) Only the 50 Hz data are indicated on the rating plate.
- 5) Cannot be used for motors in UL version (order code **D31**). Cannot be used for motors according to CSA approval (order code **D40**) for motor series 1PP7 frame size 180 to 200. The grease lifetime specified in catalog part 0 "Introduction" refers to CT 40 °C. When the coolant temperature rises by 10 K, the grease lifetime or relubrication interval is halved.
- 6) Not available for 2-pole motors.
- 7) Possible up to 600 V max. Order with voltage code **9** and order code for voltage and frequency. The rated voltage is indicated on the rating plate.
- 8) Order with voltage code **9** and order code for voltage and frequency. The rated voltage is indicated on the rating plate.
- 9) Not possible for 2-pole 1PP4 motors, frame size 315 L in vertical types of construction; bearings for increased cantilever forces at vibration quantity level B available on request for 1PP4 motors. Not possible for 1PP4 motors in the combination "Concentricity of the shaft extension, coaxiality and linear movement in accordance with DIN 42955 Tolerance R for flange-mounting motors" – order code **K04**.
- 10) Additional charge for 2-pole motors. With 4-pole to 8-pole motors, standard version.
- 11) Can be combined with deep-groove bearings of series 60... 62... and 63... Not possible with parallel roller bearings (e.g. bearings for increased cantilever forces, order code **K20**).
- 12) Possible for motors of frame size 315 and above in vertical types of construction or 2-pole for version with second shaft extension on request. Version with protective cover not possible.
- 13) When motors are ordered that have a longer or shorter shaft extension than normal, the required position and length of the featherkey way must be specified in a sketch. It must be ensured that only featherkeys in accordance with DIN 6885, Form A are permitted to be used. The featherkey way is positioned centrally on the shaft extension. The length is defined by the manufacturer normatively. Not valid for: Conical shafts, non-standard threaded journals, non-standard shaft tolerances, friction welded journals, extremely "thin" shafts, special geometry dimensions (e.g. square journals), hollow shafts. Valid for non-standard shaft extensions DE or NDE. The featherkeys are supplied in every case. For order codes **Y55** and **K16**:
  - Dimensions D and DA ≤ internal diameter of roller bearing (see dimension tables under "Dimensions")
  - Dimensions E and EA ≤ 2 x length E (normal) of the shaft extension
 For an explanation of the order codes, see catalog part 0 "Introduction".

### Overview

#### *Slide rails with fixing bolts and tensioning screws to DIN 42923*

Slide rails are used to tension the belt of a machine easily and conveniently when a belt tightener is not available. They are fixed to the base using stone bolts or foundation blocks.

The assignment of slide rails to motor size can be found in DIN 42923. For motors of frame sizes 355 to 450, there are no standardized slide rails (please inquire).

Available from:  
Lütgert & Co. GmbH  
Postfach 42 51  
33276 Gütersloh, Germany  
Tel. +49 (0)5241-7407-0  
Fax +49 (0)5241-7407-90

<http://www.luetgert-antriebe.de>  
e-mail: [info@luetgert-antriebe.de](mailto:info@luetgert-antriebe.de)

#### *Foundation block acc. to DIN 799*

The foundation blocks are inserted into the stone foundation and embedded in concrete. They are used for fixing machines of medium size, slide rails, pedestal bearings, baseframes, etc. After the fixing bolts have been unscrewed, the machine can be dragged without it having to be lifted.

When the machine is initially installed, the foundation block that is bolted to the machine (without washers) and fitted with taper pins is not embedded with concrete until the machine has been fully aligned. In this case, the machine is positioned 2 to 3 mm lower. The difference in shaft height is compensated by inserting shims on final installation. The taper pins safeguard the exact position of the machine when it is repeatedly removed and replaced without the need for realignment.

Available from:  
Lütgert & Co. GmbH  
Postfach 42 51  
33276 Gütersloh, Germany  
Tel. +49 (0)5241-7407-0  
Fax +49 (0)5241-7407-90

<http://www.luetgert-antriebe.de>  
e-mail: [info@luetgert-antriebe.de](mailto:info@luetgert-antriebe.de)

#### *Taper pins to DIN 258 with threaded ends and constant taper lengths*

Taper pins are used for components that are repeatedly removed. The drilled hole is ground conical using a conical reamer until the pin can be pushed in by hand until the cone shoulder lies 3 to 4 mm above the rim of the hole.

It can then be driven in using a hammer until it is correctly seated. The pin is removed from the drilled hole by screwing on the nut and tightening it.

Standardized taper pins are available from general engineering suppliers.

Available from:  
Otto Roth GmbH & Co. KG  
Rutesheimer Straße 22  
70499 Stuttgart, Germany  
Tel. +49 (0)7 11-1388-0  
Fax +49 (0)7 11-1388-233

<http://www.ottoroth.de>  
e-mail: [info@ottoroth.de](mailto:info@ottoroth.de)

#### *Couplings*

The motor from Siemens is connected to the machine or gear unit through a coupling. Flender is an important coupling manufacturer with a wide range of products. For standard applications, Siemens recommends that elastic couplings of Flender types N-Eupex and Rupex or torsionally rigid couplings of types Arpex and Zapex are used. For special applications, Fludex and Elpex couplings are recommended.

Source of supply:  
Siemens contact partner – ordering from Catalog  
Siemens MD 10.1 "FLENDER Standard Couplings"

or

A. Friedr. Flender AG  
Kupplungswerk Mussum  
Industriepark Bocholt  
Schlavenhorst 100  
46395 Bocholt, Germany  
Tel. +49 (0)2871-922185  
Fax +49 (0)2871-922579

<http://www.flender.com>  
e-mail: [couplings@flender.com](mailto:couplings@flender.com)

# IEC Squirrel-Cage Motors

## Fan motors

### Accessories

#### More information

##### *Spare motors and repair parts*

- Supply commitment for spare motors and repair parts following delivery of the motor
  - For up to 5 years, in the event of total motor failure, Siemens will supply a comparable motor with regard to the mounting dimensions and functions (the type series may vary).
  - Repair parts will be supplied for up to 5 years.
  - For up to 10 years, Siemens will provide information and will, if necessary, supply documentation for repair parts.
- When repair parts are ordered, the following details must be provided:
  - Designation and part number
  - Order No. and factory number of the motor

Example for ordering a fan cover 1LA7,  
frame size 160 M, 4-pole:

**Fan cover No. 7.40,  
1LA7 163-4AA60, factory number J783298901018**

- For bearing types, see the "Introduction".
- Repair parts for 1MJ6, 1MJ7, 1MJ8, 1MJ1, 1ME8, 1ML8, 1LG8 motors and smoke-extraction motors are available on request.
- For standard components, a supply commitment does not apply.
- Support – Hotline  
In Germany  
Tel.: 0180/5050448

National telephone numbers can be found on the Internet page:  
<http://www.siemens.com/automation/service&support>

# IEC Squirrel-Cage Motors

## Fan motors

### Dimensions

#### Overview

#### Overall dimensions

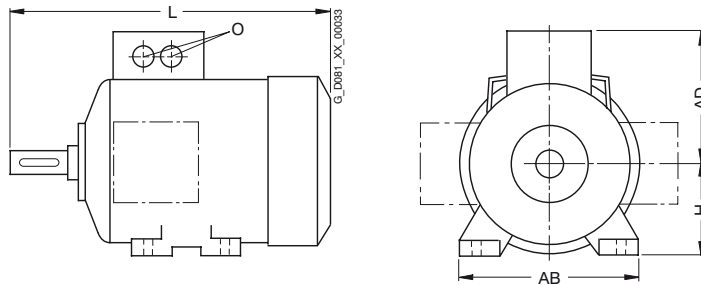

Frame size	Type	Number of poles	Dimensions				
			L	AD	H	AB	O
63 M	1PP7		172	101	63	120	1 x M16 x 1.5
							1 x M25 x 1.5
71 M	1PP7		207	111	71	132	1 x M16 x 1.5 1 x M25 x 1.5
80 M	1LA7		273.5	120	80	150	1 x M16 x 1.5 1 x M25 x 1.5
	1PP7		237	120	80	150	1 x M16 x 1.5 1 x M25 x 1.5
90 S/ 90 L	1LA7		331	128	90	165	1 x M16 x 1.5 1 x M25 x 1.5
	1PP7		286	128	90	165	1 x M16 x 1.5 1 x M25 x 1.5
100 L	1LA7		372	135	100	196	2 x M32 x 1.5
	1PP7		331	135	100	196	2 x M32 x 1.5
112 M	1LA7		393	148	112	226	2 x M32 x 1.5
	1PP7		349	148	112	226	2 x M32 x 1.5
132 S/ 132 M	1LA7		452.5	167	132	256	2 x M32 x 1.5
	1PP7		397	167	132	256	2 x M32 x 1.5
160 M/ 160 L	1LA7		588	197	160	300	2 x M40 x 1.5
	1PP7		529	197	160	300	2 x M40 x 1.5
180 M/ 180 L	1LA5		712	258	180	339	2 x M40 x 1.5
	1LG4		669	262	180	339	2 x M40 x 1.5
	1PP4		562	262	180	339	2 x M40 x 1.5
	1PP4 188		613	262	180	339	2 x M40 x 1.5
	1PP5		611	258	180	339	2 x M40 x 1.5

Frame size	Type	Number of poles	Dimensions				
			L	AD	H	AB	O
200 L	1LA5		769.5	305	200	388	2 x M50 x 1.5
	1LG4		720	300	200	378	2 x M50 x 1.5
	1PP4		617	300	200	378	2 x M50 x 1.5
	1PP4 208	2, 6	674	300	200	378	2 x M50 x 1.5
	1PP5		675	305	200	388	2 x M50 x 1.5
225 S/ 225 M	1LG4		789	325	225	436	2 x M50 x 1.5
	1PP4		670	325	225	436	2 x M50 x 1.5
	1PP4 223	2	640	325	225	436	2 x M50 x 1.5
	1PP4 228	2	700	325	225	436	2 x M50 x 1.5
	1PP4 228	4, 6, 8	730	325	225	436	2 x M50 x 1.5
250 M	1LG4		887	392	250	490	2 x M63 x 1.5
	1PP4		764	392	250	490	2 x M63 x 1.5
	1PP4 258	4	834	392	250	490	2 x M63 x 1.5
280 S/ 280 M	1LG4		960	432	280	540	2 x M63 x 1.5
	1PP4		830	432	280	540	2 x M63 x 1.5
	1PP4 288	2, 4	940	432	280	540	2 x M63 x 1.5
315 S/ 315 M/ 315 L	1LG4 310		1102	500	315	610	2 x M63 x 1.5
	1PP4 310	2	925	500	315	610	2 x M63 x 1.5
	1PP4 310	4, 6, 8	955	500	315	610	2 x M63 x 1.5
	1LG4 313		1102	500	315	610	2 x M63 x 1.5
	1PP4 313	2	925	500	315	610	2 x M63 x 1.5
	1PP4 313	4, 6, 8	955	500	315	610	2 x M63 x 1.5
	1LG4 316		1262	500	315	610	2 x M63 x 1.5
	1PP4 316	2	1085	500	315	610	2 x M63 x 1.5
	1PP4 316	4, 6, 8	1115	500	315	610	2 x M63 x 1.5
	1LG4 317		1262	500	315	610	2 x M63 x 1.5
	1PP4 317	2	1085	500	315	610	2 x M63 x 1.5
	1PP4 317	4, 6, 8	1115	500	315	610	2 x M63 x 1.5
1PP4 318	6	1255	500	315	610	2 x M63 x 1.5	
1PP4 318	8	1115	500	315	610	2 x M63 x 1.5	

#### Notes on the dimensions

■ Dimension designations according to DIN EN 50347 and IEC 60072.

#### ■ Fits

The shaft extensions specified in the dimension tables (DIN 748) and centering spigot diameters (DIN EN 50347) are machined with the following fits:

Dimension designation	ISO fit DIN ISO 286-2	
D, DA	to 30	j6
	over 30 to 50	k6
	over 50	m6
N	to 250	j6
	over 250	h6
F, FA		h9
K		H17
S	Flange (FF)	H17

The drilled holes of couplings and belt pulleys should have an ISO fit of at least H7.

#### ■ Dimension tolerances

For the following dimension designations, the permissible deviations are given below:

Dimension designation	Dimension	Permitted deviation
H	to 250	- 0.5
	over 250	- 1.0
E, EA		- 0.5

Keyways and feather keyways (dimensions GA, GC, F and FA) are made in compliance with DIN 6885 Part 1.

■ All dimensions are specified in mm.



# IEC Squirrel-Cage Motors

## Fan motors

### Dimensions

#### Dimensional drawings

Aluminum series 1LA7 and 1LA5, frame sizes 80 M to 200 L · pole-changing version

#### Type of construction IM B3

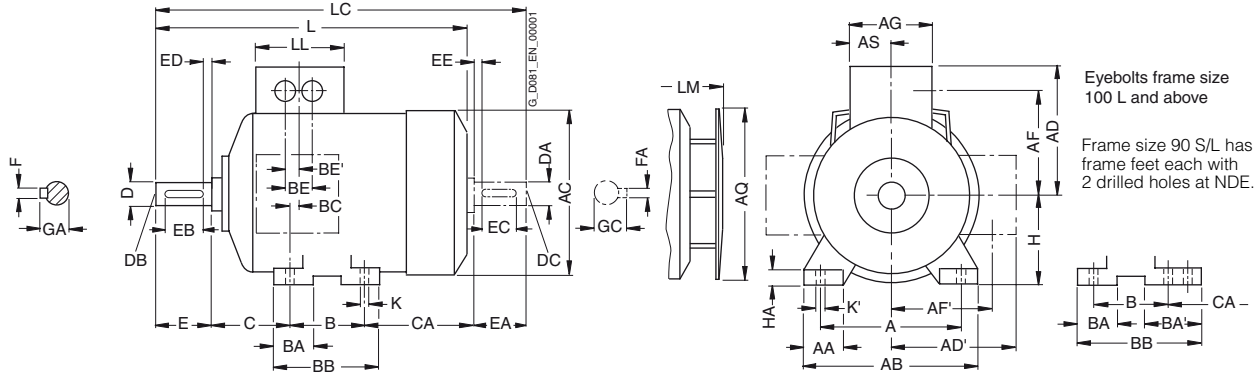

#### Types of construction IM B5 and IM V1

For flange dimensions, see Page 7/64 (Z = the number of retaining holes)

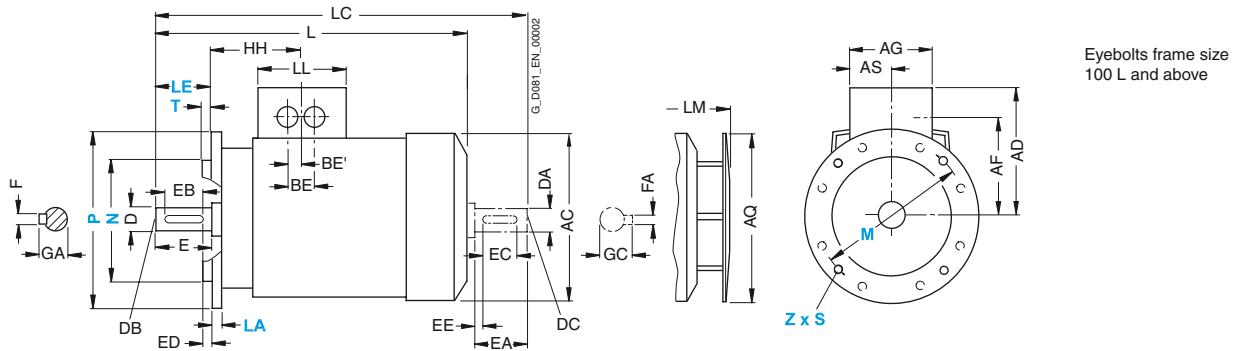

7

For motor	Frame size	Type	Dimension designation acc. to IEC																					
			A	AA	AB	AC <sup>1)</sup>	AD <sup>2)</sup>	AD'	AF <sup>2)</sup>	AF'	AG <sup>2)</sup>	AQ	AS	B*	BA	BA'	BB	BC	BE <sup>2)</sup>	BE' <sup>2)</sup>	C	CA*	H	HA
	80 M	1LA7 080 1LA7 083	125	30.5	150	163	120	120	97	97	75	124	37.5	100	32	-	118	14	32	18	50	94	80	8
	90 S 90 L	1LA7 090 1LA7 096	140	30.5	165	180	128	128	105	105	75	170	37.5	100 125	33	54	143	23	32	18	56	143 118	90	10
	100 L	1LA7 106 1LA7 107	160	42	196	203	135	163	78	123	120	170	60	140	47	-	176	39	42	21	63	125	100	12
	112 M	1LA7 113	190	46	226	227	148	176	91	136	120	170	60	140	47	-	176	32	42	21	70	141	112	12
	132 S	1LA7 130 1LA7 131	216	53	256	267	167	194	107	154	140	250	70	140	49	-	180	39	42	21	89	162.5	132	15
	132 M	1LA7 133 1LA7 134	216	53	256	267	167	194	107	154	140	250	70	178	49	-	218	39	42	21	89	124.5	132	15
	160 M	1LA7 163 1LA7 164	254	60	300	320	197	226	127	183	165	250	82.5	210	57	-	256	52.5	54	27	108	183	160	18
	160 L	1LA7 166	254	60	300	320	197	226	127	183	165	250	82.5	254	57	-	300	52.5	54	27	108	139	160	18
	180 M	1LA5 183	279	69.5	339	363	258	258	216	216	152	340	71	241	50	-	287	38	54	27	121	259	180	18
	180 L	1LA5 186	279	69.5	339	363	258	258	216	216	152	340	71	279	50	-	325	38	54	27	121	221	180	18
	200 L	1LA5 206 1LA5 207	318	83	388	402	305	305	252	252	260	340	96	305	58.5	-	355	45	85	42.5	133	239	200	24

\* This dimension is assigned in DIN EN 50347 to the frame size listed.

1) Measured across the bolt heads.

2) The values increase if the connection box is rotated or if a brake is mounted. Further information is provided by the dimension sheet generator in SD configurator.



#### Dimensional drawings

Aluminum series 1LA7 and 1LA5, frame sizes 80 M to 200 L · pole-changing version

#### Type of construction IM B35

For flange dimensions, see Page 7/64 (Z = the number of retaining holes)

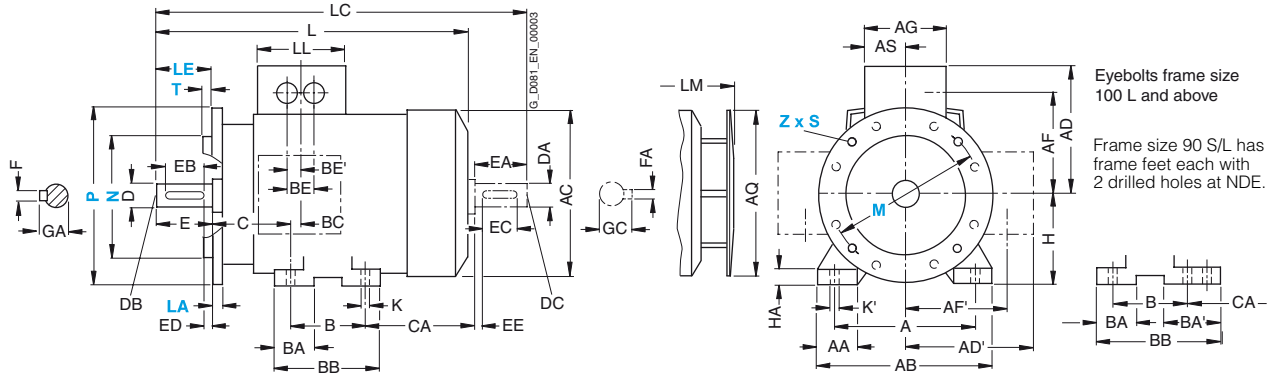

#### Type of construction IM B14

Type of construction IM B14 not possible for 1LA5 motors, frame sizes 180 M to 200 L

For flange dimensions, see Page 7/64 (Z = the number of retaining holes)

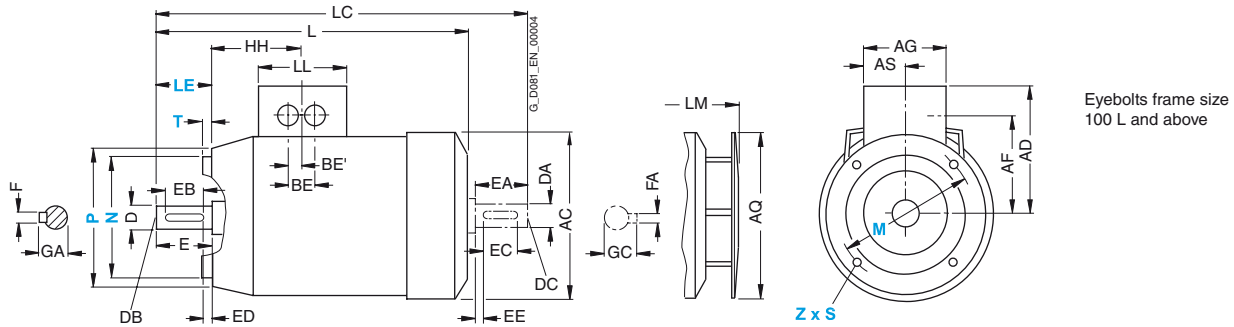

For motor Frame size	Type	Dimension designation acc. to IEC						DE shaft extension						NDE shaft extension								
		HH	K	K'	L	LC	LL	LM	D	DB	E	EB	ED	F	GA	DA	DC	EA	EC	EE	FA	GC
80 M	1LA7 080	63.5	9.5	13.5	273.5	324	75	299.5	19	M6	40	32	4	6	21.5	19	M6	40	32	4	6	21.5
	1LA7 083					364																
90 S 90 L	1LA7 090	79	10	14	331	389	75	382.5	24	M8	50	40	5	8	27	19	M6	40	32	4	6	21.5
	1LA7 096																					
100 L	1LA7 106	102	12	16	372	438	120	423.5	28	M10	60	50	5	8	31	24	M8	50	40	5	8	27
	1LA7 107																					
112 M	1LA7 113	102	12	16	393	461	120	444.5	28	M10	60	50	5	8	31	24	M8	50	40	5	8	27
132 S	1LA7 130	128	12	16	452.5	551.5	140	505	38	M12	80	70	5	10	41	38	M12	80	70	5	10	41
	1LA7 131																					
132 M	1LA7 133	128	12	16	452.5	551.5	140	505	38	M12	80	70	5	10	41	38	M12	80	70	5	10	41
	1LA7 134																					
160 M	1LA7 163	160.5	15	19	588	721	165	640.5	42	M16	110	90	10	12	45	42	M16	110	90	10	12	45
	1LA7 164																					
160 L	1LA7 166	160.5	15	19	588	721	165	640.5	42	M16	110	90	10	12	45	42	M16	110	90	10	12	45
180 M	1LA5 183	159	15	19	712	841	132	793.5	48	M16	110	100	5	14	51.5	48	M16	110	100	5	14	51.5
	1LA5 186	159	15	19	712	841	132	793.5	48	M16	110	100	5	14	51.5	48	M16	110	100	5	14	51.5
200 L	1LA5 206	178	19	25	769.5	897	192	850	55	M20	110	100	5	16	59	55	M20	110	100	5	16	59
	1LA5 207																					

# IEC Squirrel-Cage Motors

## Fan motors

### Dimensions

#### Dimensional drawings

Cast-iron series 1LG4, frame sizes 180 M to 315 L · pole-changing version

#### Type of construction IM B3

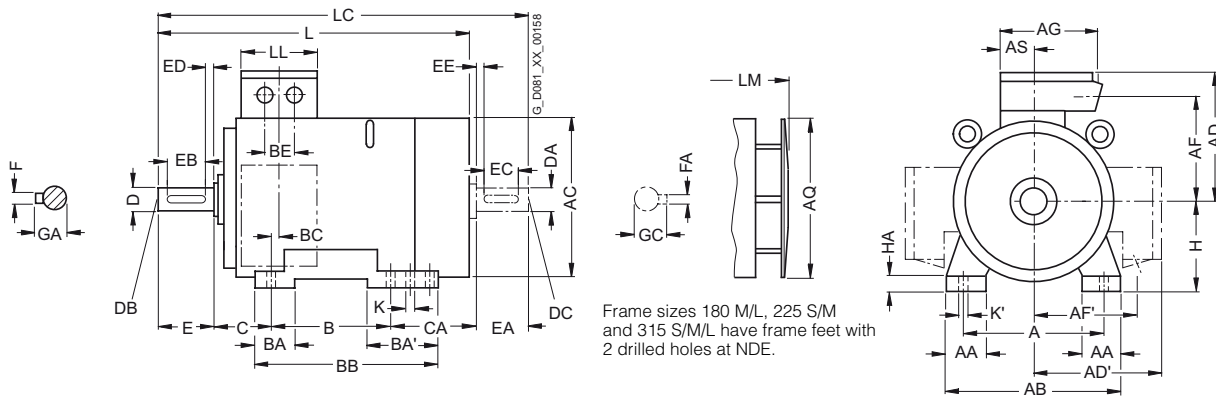

#### Types of construction IM B5 and IM V1

For flange dimensions, see Page 7/64 (Z = the number of retaining holes)

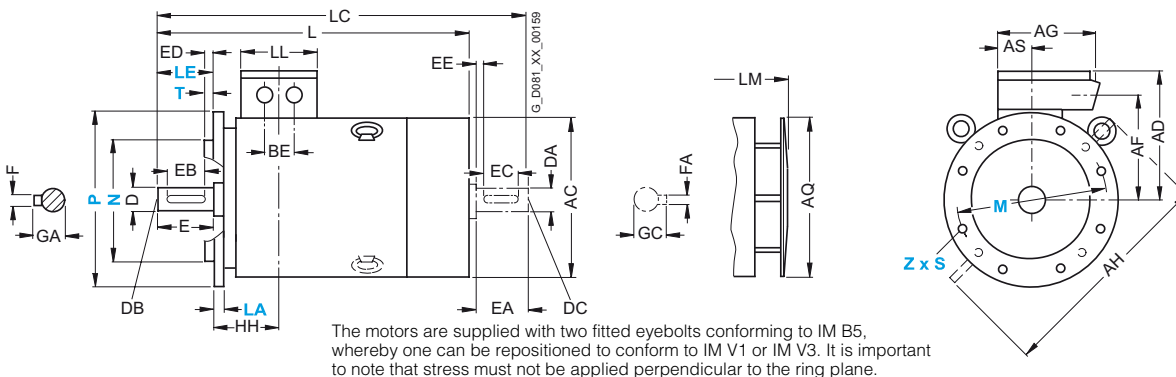

For motor Frame size	Type	Dimension designation acc. to IEC																					
		A	AA	AB	AC <sup>1)</sup>	AD	AD'	AF	AF'	AG	AH	AQ	AS	B*	BA	BA'	BB	BC	BE	C	CA*	H	HA
180 M	1LG4 183	279	65	339	363	262	262	220	220	152	452	340	71	241	70	111	328	36	54	121	202	180	20
180 L	1LG4 186	279	65	339	363	262	262	220	220	152	452	340	71	279	70	111	328	36	54	121	164	180	20
200 L	1LG4 207	318	70	378	402	300	300	247	247	260	512	340	96	305	80	80	355	63	85	133	177	200	25
225 S	1LG4 220	356	80	436	442	325	325	272	272	260	556	425	96	286	85	110	361	47	85	149	218	225	34
225 M	1LG4 223	356	80	436	442	325	325	272	272	260	556	425	96	311	85	110	361	47	85	149	193	225	34
250 M	1LG4 253	406	100	490	495	392	392	308	308	300	620	470	118	349	100	100	409	69	110	168	235	250	40
280 S	1LG4 280	457	100	540	555	432	432	348	348	300	672	525	118	368	100	151	479	62	110	190	267	280	40
280 M	1LG4 283	457	100	540	555	432	432	348	348	300	672	525	118	419	100	151	479	62	110	190	216	280	40
315 S	1LG4310	508	120	610	610	500	500	400	400	380	780	590	154	406	125	176	527	69	110	216	315	315	50
315 M <sup>2)</sup>	1LG4313	508	120	610	610	500	500	400	400	380	780	590	154	457	125	176	527	69	110	216	264	315	50
315 L <sup>2)</sup>	1LG4316	508	120	610	610	500	500	400	400	380	780	590	154	508	125	176	578	69	110	216	373	315	50
	1LG4317	508	120	610	610	500	500	400	400	380	780	590	154	508	155	206	648	69	110	216	513	315	50

\* This dimension is assigned in DIN EN 50347 to the frame size listed.

1) Measured across the bolt heads.

2) With order codes for connection box positions (K09, K10, K11) only fitted feet with 3 drilled holes with dimension "B" (406, 457 and 508 mm). BB will then be 666 mm.

#### Dimensional drawings

Cast-iron series 1LG4, frame sizes 180 M to 315 L · pole-changing version

#### Type of construction IM B35

For flange dimensions, see Page 7/64 (Z = the number of retaining holes)

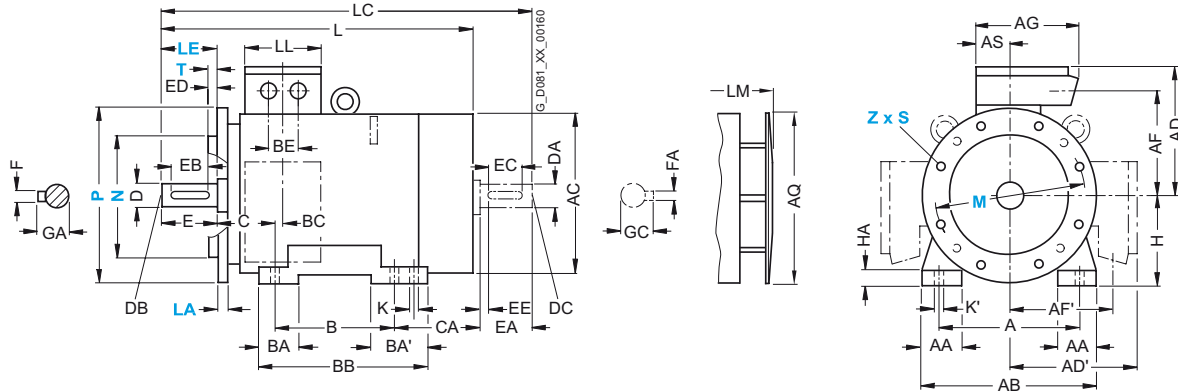

For motor		Dimension designation acc. to IEC							DE shaft extension					NDE shaft extension								
Frame size	Type	HH	K	K'	L	LC	LL	LM	D	DB	E	EB	ED	F	GA	DA	DC	EA	EC	EE	FA	GC
180 M	1LG4 183	157	15	19	669	784	132	759	48	M16	110	100	5	14	51.5	48	M16	110	100	5	14	51.5
180 L	1LG4 186	157	15	19	669	784	132	759	48	M16	110	100	5	14	51.5	48	M16	110	100	5	14	51.5
200 L	1LG4 207	196	19	25	720	835	192	810	55	M20	110	100	5	16	59	55	M20	110	100	5	16	59
225 S	1LG4 220	196	19	25	789	903	192	889	60	M20	140	125	10	18	64	55	M20	110	100	5	16	59
225 M	1LG4 223	196	19	25	789	903	192	889	60	M20	140	125	10	18	64	55	M20	110	100	5	16	59
250 M	1LG4 253	237	24	30	887	1032	236	987	65	M20	140	125	10	18	69	60	M20	140	125	10	18	64
280 S	1LG4 280	252	24	30	960	1105	236	1070	75	M20	140	125	10	20	79.5	65	M20	140	125	10	18	69
280 M	1LG4 283	252	24	30	960	1105	236	1070	75	M20	140	125	10	20	79.5	65	M20	140	125	10	18	69
315 S	1LG4310	285	28	35	1102	1247	307	1212	80	M20	170	140	25	22	85	70	M20	140	125	10	20	74.5
315 M <sup>1)</sup>	1LG4313	285	28	35	1102	1247	307	1212	80	M20	170	140	25	22	85	70	M20	140	125	10	20	74.5
315 L <sup>1)</sup>	1LG4316	285	28	35	1262	1407	307	1372	80	M20	170	140	25	22	85	70	M20	140	125	10	20	74.5
	1LG4317	285	28	35	1262	1407	307	1372	80	M20	170	140	25	22	85	70	M20	140	125	10	20	74.5

<sup>1)</sup> With order codes for connection box positions (K09, K10, K11) only fitted feet with 3 drilled holes with dimension "B" (406, 457 and 508 mm). BB will then be 666 mm.

# IEC Squirrel-Cage Motors

## Fan motors

### Dimensions

#### Dimensional drawings

Aluminum series 1PP7 and 1PP5, frame sizes 63 M to 200 L

#### Type of construction IM B3

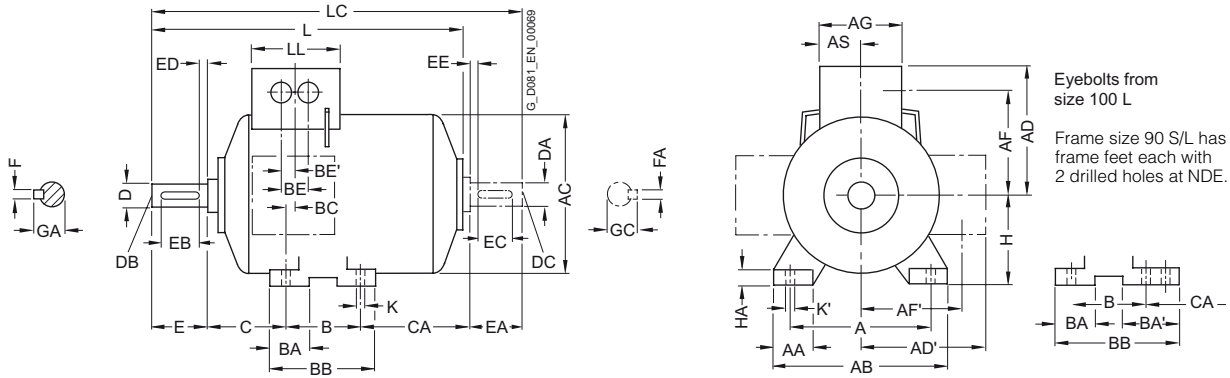

#### Types of construction IM B5 and IM V1

For flange dimensions, see Page 7/64 (Z = the number of retaining holes)

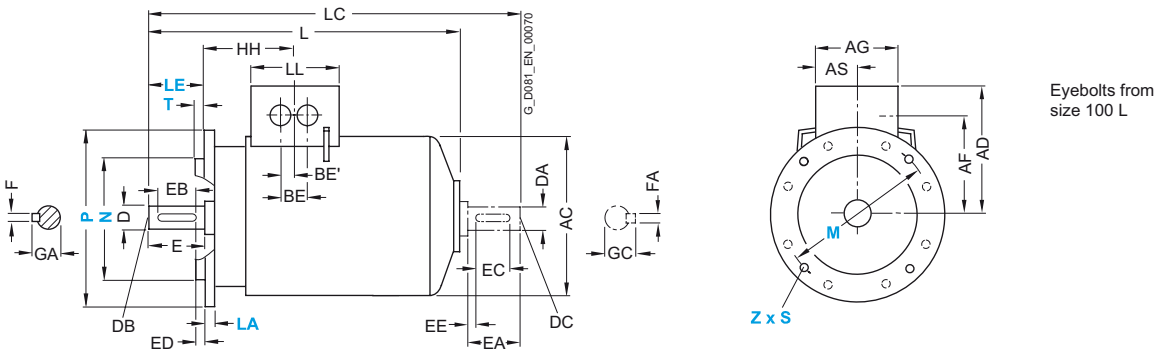

7

For motor			Dimension designation acc. to IEC																				
Frame size	Type	Number of poles	A	AA	AB	AC	AD	AD'	AF	AF'	AG	AS	B*	BA	BA'	BB	BC	BE	BE'	C	CA*	H	HA
63 M	1PP7 060 1PP7 063	2, 4, 6	100	27	120	124	101	101	78	78	75	37.5	80	28	-	96	30	32	18	40	40	63	7
71 M	1PP7 070 1PP7 073	2, 4, 6, 8	112	27	132	145	111	111	88	88	75	37.5	90	27	-	106	18	32	18	45	42	71	7
80 M	1PP7 080 1PP7 083	2, 4, 6, 8	125	30.5	150	163	120	120	97	97	75	37.5	100	32	-	118	14	32	18	50	47	80	8
90 S 90 L	1PP7 090 1PP7 096	2, 4, 6, 8	140	30.5	165	180	128	128	105	105	75	37.5	100 125	33	54	143	23	32	18	56	80 55	90	10
100 L	1PP7 106 1PP7 107	2, 4, 6, 8 4, 8	160	42	196	203	135	163	78	123	120	60	140	47	-	176	39	42	21	63	68	100	12
112 M	1PP7 113	2, 4, 6, 8	190	46	226	227	148	176	91	136	120	60	140	47	-	176	32	42	21	70	79	112	12
132 S	1PP7 130 1PP7 131	2, 4, 6, 8 2	216	53	256	267	167	194	107	154	140	70	140	49	-	180	39	42	21	89	96	132	15
132 M	1PP7 133 1PP7 134	4, 6, 8 6	216	53	256	267	167	194	107	154	140	70	178	49	-	218	39	42	21	89	58	132	15
160 M	1PP7 163 1PP7 164	2, 4, 6, 8 2, 8	254	60	300	320	197	226	127	183	165	82.5	210	57	-	256	52.5	54	27	108	107	160	18
160 L	1PP7 166	2, 4, 6, 8	254	60	300	320	197	226	127	183	165	82.5	254	57	-	300	52.5	54	27	108	63	160	18
180 M	1PP5 183	2, 4	279	69.5	339	363	258	258	216	216	152	71	241	50	-	287	38	54	27	121	145	180	18
180 L	1PP5 186	4, 6, 8	279	69.5	339	363	258	258	216	216	152	71	279	50	-	325	38	54	27	121	107	180	18
200 L	1PP5 206 1PP5 207	2, 6 2, 4, 6, 8	318	83	388	402	305	305	252	252	260	96	305	58.5	-	355	45	85	42.5	133	133	200	24

\* This dimension is assigned in DIN EN 50347 to the frame size listed.

## Dimensional drawings

## Aluminum series 1PP7 and 1PP5, frame sizes 63 M to 200 L

## Type of construction IM B14

Type of construction IM B14 not possible for 1PP5 motors, frame sizes 180 M to 200 L  
For flange dimensions, see Page 7/64 (Z = the number of retaining holes)

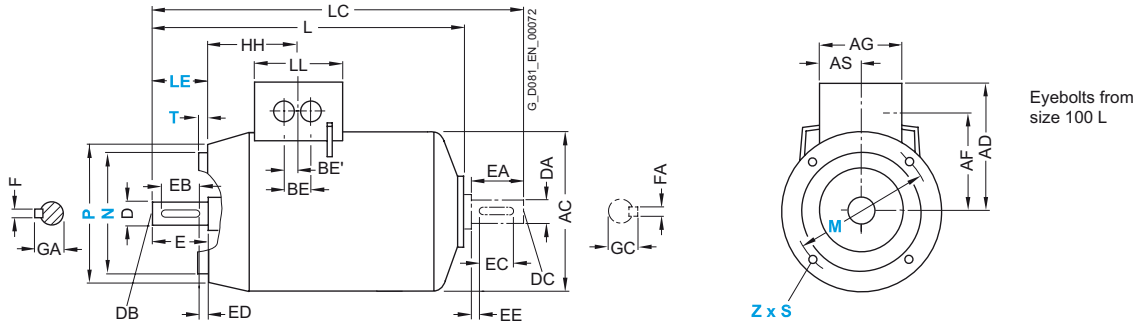

For motor		Number of poles	Dimension designation acc. to IEC						DE shaft extension					NDE shaft extension								
Frame size	Type		HH	K	K'	L	LC	LL	D	DB	E	EB	ED	F	GA	DA	DC	EA	EC	EE	FA	GC
63 M	1PP7 060 1PP7 063	2, 4, 6	69.5	7	10	172 <sup>1)</sup>	206 <sup>1)</sup>	75	11	M4	23	16	3.5	4	12.5	11	M4	23	16	3.5	4	12.5
71 M	1PP7 070 1PP7 073	2, 4, 6, 8	63.5	7	10	207	240	75	14	M5	30	22	4	5	16	14	M5	30	22	4	5	16
80 M	1PP7 080 1PP7 083	2, 4, 6, 8	63.5	9.5	13.5	237	280	75	19	M6	40	32	4	6	21.5	19	M6	40	32	4	6	21.5
90 S 90 L	1PP7 090 1PP7 096	2, 4, 6, 8	79	10	14	286	333	75	24	M8	50	40	5	8	27	19	M6	40	32	4	6	21.5
100 L	1PP7 106 1PP7 107	2, 4, 6, 8 4, 8	102	12	16	331	385 <sup>2)</sup>	120	28	M10	60	50	5	8	31	24	M8	50	40	5	8	27
112 M	1PP7 113	2, 4, 6, 8	102	12	16	349 <sup>3)</sup>	403 <sup>4)</sup>	120	28	M10	60	50	5	8	31	24	M8	50	40	5	8	27
132 S	1PP7 130 1PP7 131	2, 4, 6, 8 2	128	12	16	397	485	140	38	M12	80	70	5	10	41	38	M12	80	70	5	10	41
132 M	1PP7 133 1PP7 134	4, 6, 8 6	128	12	16	397	485	140	38	M12	80	70	5	10	41	38	M12	80	70	5	10	41
160 M	1PP7 163 1PP7 164	2, 4, 6, 8 2, 8	160.5	15	19	529	645	165	42	M16	110	90	10	12	45	42	M16	110	90	10	12	45
160 L	1PP7 166	2, 4, 6, 8	160.5	15	19	529	645	165	42	M16	110	90	10	12	45	42	M16	110	90	10	12	45
180 M	1PP5 183	2, 4	159	15	19	611	727	132	48	M16	110	100	5	14	51.5	48	M16	110	100	5	14	51.5
180 L	1PP5 186	4, 6, 8	159	15	19	611	727	132	48	M16	110	100	5	14	51.5	48	M16	110	100	5	14	51.5
200 L	1PP5 206 1PP5 207	2, 6 2, 4, 6, 8	178	19	25	675	791	192	55	M20	110	100	5	16	59	55	M20	110	100	5	16	59

<sup>1)</sup> For 1PP7 063 with type of construction code 1 (B5, IM V1 without protective cover, IM V3) the dimensions L and LC are 26 mm longer.

<sup>2)</sup> 381 mm for IM B14 type of construction.

<sup>3)</sup> 345 mm for IM B5 type of construction.

<sup>4)</sup> 399 mm for IM B5 type of construction.





# IEC Squirrel-Cage Motors

## Fan motors

### Dimensions

#### Dimensional drawings

##### Flange dimensions

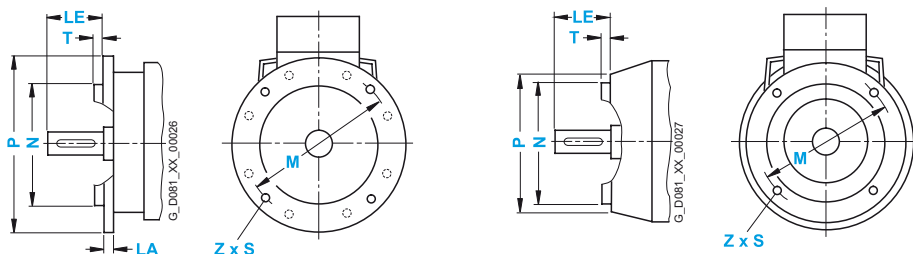

In DIN EN 50347, the frame sizes are allocated flange FF with through holes and flange FT with tapped holes.

The designation of flange A and C according to DIN 42948 (invalid since 09/2003) are also listed for information purposes. See the table below. (Z = the number of retaining holes)

Frame size	Type of construction	Flange type	Flange with through holes (FF/A) Tapped holes (FT/C)	Dimension designation acc. to IEC	Dimension designation acc. to IEC							
					LA	LE	M	N	P	S	T	Z
<b>63 M</b>	IM B5, IM B35, IM V1, IM V3	Flange	<b>FF 115</b>	A 140	8	23	115	95	140	10	3	4
	IM B14, IM B34, IM V18, IM V19	Standard flange	<b>FT 75</b>	C 90	–	23	75	60	90	M5	2.5	4
	IM B14, IM B34, IM V18, IM V19	Special flange	<b>FT 100</b>	C 120	–	23	100	80	120	M6	3	4
<b>71 M</b>	IM B5, IM B35, IM V1, IM V3	Flange	<b>FF 130</b>	A 160	9	30	130	110	160	10	3.5	4
	IM B14, IM B34, IM V18, IM V19	Standard flange	<b>FT 85</b>	C 105	–	30	85	70	105	M6	2.5	4
	IM B14, IM B34, IM V18, IM V19	Special flange	<b>FT 115</b>	C 140	–	30	115	95	140	M8	3	4
<b>80 M</b>	IM B5, IM B35, IM V1, IM V3	Flange	<b>FF 165</b>	A 200	10	40	165	130	200	12	3.5	4
	IM B14, IM B34, IM V18, IM V19	Standard flange	<b>FT 100</b>	C 120	–	40	100	80	120	M6	3	4
	IM B14, IM B34, IM V18, IM V19	Special flange	<b>FT 130</b>	C 160	–	40	130	110	160	M8	3.5	4
<b>90 S, 90 L</b>	IM B5, IM B35, IM V1, IM V3	Flange	<b>FF 165</b>	A 200	10	50	165	130	200	12	3.5	4
	IM B14, IM B34, IM V18, IM V19	Standard flange	<b>FT 115</b>	C 140	–	50	115	95	140	M8	3	4
	IM B14, IM B34, IM V18, IM V19	Special flange	<b>FT 130</b>	C 160	–	50	130	110	160	M8	3.5	4
<b>100 L</b>	IM B5, IM B35, IM V1, IM V3	Flange	<b>FF 215</b>	A 250	11	60	215	180	250	14.5	4	4
	IM B14, IM B34, IM V18, IM V19	Standard flange	<b>FT 130</b>	C 160	–	60	130	110	160	M8	3.5	4
	IM B14, IM B34, IM V18, IM V19	Special flange	<b>FT 165</b>	C 200	–	60	165	130	200	M10	3.5	4
<b>112 M</b>	IM B5, IM B35, IM V1, IM V3	Flange	<b>FF 215</b>	A 250	11	60	215	180	250	14.5	4	4
	IM B14, IM B34, IM V18, IM V19	Standard flange	<b>FT 130</b>	C 160	–	60	130	110	160	M8	3.5	4
	IM B14, IM B34, IM V18, IM V19	Special flange	<b>FT 165</b>	C 200	–	60	165	130	200	M10	3.5	4
<b>132 S, 132 M</b>	IM B5, IM B35, IM V1, IM V3	Flange	<b>FF 265</b>	A 300	12	80	265	230	300	14.5	4	4
	IM B14, IM B34, IM V18, IM V19	Standard flange	<b>FT 165</b>	C 200	–	80	165	130	200	M10	3.5	4
	IM B14, IM B34, IM V18, IM V19	Special flange	<b>FT 215</b>	C 250	–	80	215	180	250	M12	4	4
<b>160 M, 160 L</b>	IM B5, IM B35, IM V1, IM V3	Flange	<b>FF 300</b>	A 350	13	110	300	250	350	18.5	5	4
	IM B14, IM B34, IM V18, IM V19	Standard flange	<b>FT 215</b>	C 250	–	110	215	180	250	M12	4	4
	IM B14, IM B34, IM V18, IM V19	Special flange	<b>FT 265</b>	C 300	–	110	265	230	300	M12	4	4
<b>180 M, 180 L</b>	IM B5, IM V1, IM V3	Flange	<b>FF 300</b>	A 350	13	110	300	250	350	18.5	5	4
<b>200 L</b>	IM B5	Flange	<b>FF 350</b>	A 400	15	110	350	300	400	18.5	5	4
<b>225 S, 225 M</b> 2-pole 4-pole to 8-pole	IM B5, IM V1, IM V3	Flange	<b>FF 400</b>	A 450	16	110	400	350	450	18.5	5	8
<b>250 M</b>	IM B5, IM V1, IM V3	Flange	<b>FF 500</b>	A 550	18	140	500	450	550	18.5	5	8
<b>280 S, 280 M</b>	IM B5, IM V1, IM V3	Flange	<b>FF 500</b>	A 550	18	140	500	450	550	18.5	5	8
<b>315 S, 315 M, 315 L</b> 2-pole 4-pole to 8-pole	IM B5, IM V1, IM V3	Flange	<b>FF 600</b>	A 660	22	140	600	550	660	24	6	8



#### More information

##### *Dimension sheet generator*

(part of the SD configurator)

A dimension drawing can be created in the SD configurator for every configurable motor. A dimension drawing can be requested for every other motor.

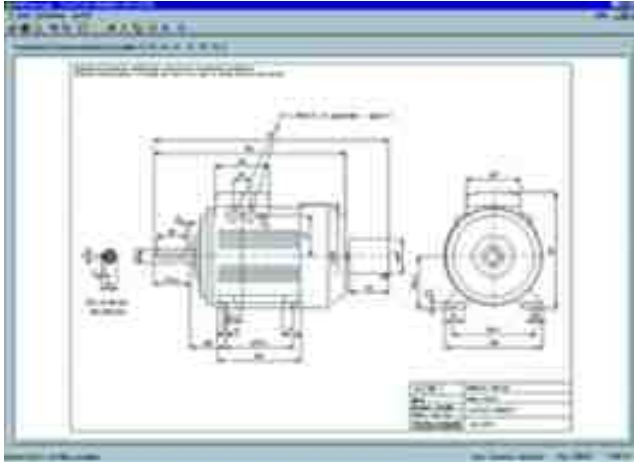

When a complete Order No. is entered with or without order codes, a dimension drawing can be called up under the "Documentation" tab.

These dimension drawings can be presented in different views and sections and printed.

The corresponding dimension sheets can be exported, saved and processed further in DXF format (interchange/import format for CAD systems) or as bitmap graphics.

The SD configurator has been integrated into the electronic Catalog CA 01 as a selection aid (for further information, see catalog part 11 "Appendix", "Selection tool SD configurator").

The interactive Catalog CA 01 can be ordered from your local Siemens sales representative or on the Internet at

<http://www.siemens.com/automation/CA01>

At this address, you will also find links to Tips & Tricks and to downloads for function or content updates.

Order number for CA 01 10/2008, English International:

DVD: E86060-D4001-A510-C7-7600

# IEC Squirrel-Cage Motors

## Fan motors

Notes

7

# Compressor motors



<b>8/2</b>	<b>Orientation</b>
8/2	Overview
8/2	Benefits
8/2	Application
8/2	More information
<b>8/3</b>	<b>Surface-cooled motors up to frame size 315 L Aluminum and cast-iron housing</b>
8/3	Overview
<b>8/3</b>	<b>Surface-cooled motors frame size 315 and above Cast-iron housing</b>
8/3	Overview
<b>8/4</b>	<b>Special versions</b>
8/4	Overview
<b>8/4</b>	<b>Accessories</b>
8/4	Overview
<b>8/4</b>	<b>Dimensions</b>
8/4	Overview

# IEC Squirrel-Cage Motors

## Compressor motors

### Orientation

#### Overview



The compressor motors are used preferentially in compressors for direct drive. In compressors with belt drive, the cantilever forces must be taken into account.

Due to the necessary compactness and confined space within the compressor, it is recommended that the following are used:

- Motors with increased output
- If required, versions with protruding cables instead of a connection box
- Special versions for high-speed applications – possible on request
- With converter-fed operation, winding monitoring with embedded KTY 84-130 temperature sensors or bimetal temperature sensors and additional insulated bearings for wide output ranges.

#### Benefits

The implemented motors offer the user the following advantages:

- Depending on the motor type used, service factors of up to 1.25 are possible, i.e. the motor can be continuously overloaded with 25 % of the rated output.
- Motors with increased efficiency to CEMEP EFF 1 or EPACT lead to significant energy savings under typical continuous duty. Please inquire regarding any efficiency requirements that exceed this.
- Noise-optimized versions.
- Under converter-fed operation, by setting the precise speed and therefore the operating point, a considerable energy saving can be achieved combined with reduced stress on the plant.
- The motors are suitable, in general, for mains-fed operation up to 690 V and converter-fed operation up to 460 V (with motor series 1LA8 to 500 V) (voltage rise times  $t_{\text{v}} > 0.1$  ms).
- Extensive experience is available in customized applications especially with regard to special flanges and special bearings.

#### Application

The motors can be used for the following compressor types:

- Screw compressors
- Reciprocating compressors
- Rotary blowers

#### More information

For more information, please contact your local Siemens AG contact – see “Siemens contacts worldwide” in the Appendix.

# IEC Squirrel-Cage Motors

## Compressor motors

Surface-cooled motors up to frame size 315 L  
Aluminum and cast-iron housing

### Overview

Recommended motor types:

- Self-ventilated motors with high efficiency according to CEMEP EFF1 – Aluminum series 1LA9 in the output range from 0.06 to 37 kW, 50 and 60 Hz
- Self-ventilated motors with high efficiency according to CEMEP EFF1 – Cast-iron series 1LG6 in the output range from 11 to 200 kW, 50 and 60 Hz
- Self-ventilated motors with high efficiency according to CEMEP EFF1 – Aluminum series 1LE1 in the output range from 0.75 to 18.5 kW, 50 and 60 Hz
- Self-ventilated motors with increased output – Aluminum series 1LA9 and cast-iron series 1LG4 in output range from 3 to 110 kW, 50 and 60 Hz
- Self-ventilated motors with high efficiency and increased output are available on request
- Self-ventilated motors with improved efficiency according to CEMEP EFF2 with increased output – Aluminum series 1LE1 in the output range from 2.2 to 22 kW, 50 and 60 Hz
- Self-ventilated motors with high efficiency according to CEMEP EFF1 with increased output – Aluminum series 1LE1 in the output range from 2.2 to 22 kW, 50 and 60 Hz

For technical specifications and selection and ordering data, see catalog parts 1 “New Generation 1LE1/1PC1” and 2 “Standard motors up to frame size 315 L”.

Surface-cooled motors frame size 315 and above  
Cast-iron housing

### Overview

Recommended motor types:

- Non-standard motor for mains-fed and converter-fed operation – cast-iron housing 1LA8

For technical specifications and selection and ordering data, see catalog part 3 “Non-standard motors frame size 315 and above”.

# IEC Squirrel-Cage Motors

## Compressor motors

### Special versions

#### Overview

##### *Recommended special versions for mains-fed and converter-fed operation*

- Motor temperature sensing using built-in temperature sensor KTY 84-130 – order code **A23** for 1LE1 – 15th position of the Order No. letter **F**
- Insulated bearing cartridge at non-drive-end (NDE) – order code **L27**
- External earthing – order code **L13** for 1LE1 – order code **H04**
- 6 protruding cable ends
  - 0.5 m long – order code **L47** for 1LE1 – order code **R22**
  - 1.5 m long – order code **L48** for 1LE1 – order code **R23**
  - 3.0 m long – order code **L49** for 1LE1 – order code **R24**

##### *Other special versions*

For other special versions, see catalog parts 2 “Standard motors up to frame size 315 L” and 3 “Non-standard motors frame size 315 and above”.

### Accessories

#### Overview

See catalog parts 1 “New Generation 1LE1/1PC1”, 2 “Standard motors up to frame size 315 L” and 3 “Non-standard motors frame size 315 and above”.

### Dimensions

#### Overview

See dimensions under catalog parts 1 “New Generation 1LE1/1PC1”, 2 “Standard motors up to frame size 315 L” and 3 “Non-standard motors frame size 315 and above”.

# Smoke-extraction motors



<b>9/2</b>	<b>Orientation</b>
9/2	Overview
9/3	Benefits
9/3	Application
9/4	Technical specifications
9/7	Selection and ordering data
9/7	More information
<b>9/8</b>	<b>Self-ventilated motors for temperature/time classes F200 and F300</b>
	<b>Aluminum series 1LA7 and 1LA5, cast-iron series 1LG6</b>
9/8	Selection and ordering data
<b>9/14</b>	<b>Forced-air cooled motors for temperature/time classes F200 and F300</b>
	<b>Aluminum series 1PP7 and 1PP5, cast-iron series 1PP6</b>
9/14	Selection and ordering data
<b>9/20</b>	<b>Self-ventilated motors for temperature/time class F400</b>
	<b>Cast-iron series 1LA6 and 1LG6</b>
9/20	Selection and ordering data
<b>9/26</b>	<b>Forced-air cooled motors for temperature/time class F400</b>
	<b>Cast-iron series 1PP6</b>
9/26	Selection and ordering data
<b>9/32</b>	<b>Special versions</b>
9/32	Selection and ordering data
9/32	• Voltages
9/33	• Types of construction
9/34	• Options
<b>9/42</b>	<b>Accessories</b>
9/42	Overview
9/42	More information
<b>9/43</b>	<b>Dimensions</b>
9/43	Overview

# IEC Squirrel-Cage Motors

## Smoke-extraction motors

### Orientation

### Overview



The low-voltage motors with squirrel-cage rotors for implementation in automatic smoke and heat extraction units to EN 12101-3 are mainly designed for driving smoke extraction fans. For this reason, they are known as smoke-extraction motors. They are mainly used in buildings or structures in which smoke control is necessary due to their shape and arrangement.

#### Temperature/time classification according to EN 12101-3

- F200 corresponds to 200 °C for 120 min.
- F300 corresponds to 300 °C for 60 min.
- F400 corresponds to 400 °C for 120 min.

#### Testing and test certificates

The smoke-extraction motors are tested by the Research and Testing Laboratory of the Department of Air-Conditioning Systems and Building Services Installations of the Technical University of Munich in accordance with EN 12101-3.

Test conditions for F200/F300:

- Temperature **300 °C**
- Time **120 min.**

The test certificates are available.



The motors are manufactured with aluminum or cast-iron housings in accordance with the smoke classes. The smoke-extraction motors are based on the standard motors and comprise the following motor types:

- Temperature/time classes F200 and F300
  - Self-ventilated motors – Aluminum series 1LA7 and 1LA5, cast-iron series 1LG6 – Version with integrated fan (metal)
  - Self-ventilated motors – Aluminum series 1LA7 and 1LA5 **double pole-changing with square-law load torque** – Version with integrated fan (metal)
  - Forced-air cooled motors – Aluminum series 1PP7 and 1PP5, cast-iron series 1PP6 – Version without integrated fan, located in air flow of fan to be driven
  - Forced-air cooled motors – Aluminum series 1PP7 and 1PP5 **double pole-changing with square-law load torque** – Version without integrated fan, located in air flow of fan to be driven
- Temperature/time classes F400
  - Self-ventilated motors – Cast-iron series 1LA6 and 1LG6 – Version with integrated fan (metal)
  - Self-ventilated motors – Cast-iron series 1LA6 **double pole-changing with square-law load torque** – Version with integrated fan (metal)
  - Forced-air cooled motors – Cast-iron series 1PP6 – Version without integrated fan, located in air flow of fan to be driven
  - Forced-air cooled motors – Cast-iron series 1PP6 **double pole-changing with square-law load torque** – Version without integrated fan, located in air flow of fan to be driven.

The resonance of mountings and reactions from driven machines can cause high levels of vibration in the overall equipment unit. This has a significant effect on the expected service life of the bearing.

These vibrations are evaluated in accordance with Zones A and B according to ISO 10816.



### Benefits

The smoke-extraction motors operate as so-called "Dual-function motors":

- Normal operation (no instance of fire):  
Incoming/outgoing air flow
- Fault operation (in case of fire):
  - Removal of smoke from escape and access routes
  - Supporting fire fighting by creating a smoke-free zone
  - Protecting devices and equipment
  - Reducing the heat stress of components during a fire
  - Reducing secondary damage due to thermal bi-products and hot gases

The smoke-extraction motors offer the user a number of advantages:

- The assignment of standard outputs is unchanged. This means that a larger construction size is not required for smoke-extraction motors.
- Smoke-extraction motors are generally equipped with located bearings at the drive-end (DE) of the motor.
- A rating plate for conditions of fire is screwed onto the motor.
- Cables protruding from the non-drive-end (NDE) are included in the scope of supply.
- Radial-flow and axial-flow fan drive are possible.
  - Self-ventilated motors of series 1LA/1LG with a metal fan impeller can be used as radial-flow fan drives.
  - Forced-air cooled motors of series 1PP can be used as axial-flow fan drives taking into account the required volumetric flow for motor cooling. In this case the driven fan performs the ventilation.

### Application

The smoke-extraction motors are designed for use in automatic smoke and heat extraction units to EN 12101-3.

Typical application examples include:

- Tunnels
- Single and multi-storey shopping centers
- Industrial buildings and warehouses
- Building complexes and atriums
- Theatres
- Indoor car parks
- Staircases

# IEC Squirrel-Cage Motors

## Smoke-extraction motors

### Orientation

#### Technical specifications

##### Standards and specifications

In addition to the relevant standards and regulations, EN 12101-3 applies for non-portable fire-fighting systems:

Systems for controlling smoke and heat flows, part 3, specifications for smoke and heat extraction units.

##### Voltage and frequency

###### Rated voltages according to IEC 60034-1

- 230 VΔ 50 Hz
- 400 VΔ 50 Hz and 400 VY 50 Hz
- 500 VΔ 50 Hz and 500 VY 50 Hz
- 690 VY 50 Hz

Non-standard voltages (voltage code **9** and order code **L1Y**) as well as 60 Hz are available on request, only for 4, 6, 8-pole motors as well as 6/4 and 8/4-pole motors with  $n_{max.} = 3000$  rpm)

The following rating plates are available for the smoke-extraction motors:

- Rating plate  
For the listed rated voltages with 50 Hz output data.
- Fire event plate  
Complete with number and year of issue of the European standard, temperature/time class and minimum duration of function.

All plates are resistant to corrosion. A second set of plates is included with the motor, loose.

##### Rated output, duty type, number of poles

The rated output applied for continuous duty (normal duty) according to IEC 60034-1, for a frequency of 50 Hz, coolant temperatures of up to 40 °C, site altitude of up to 1000 m above sea level.

Derating is necessary at higher coolant temperatures and site altitudes (reduction factor  $k_{HT}$ ), see table below.

##### Reduction factor $k_{HT}$ for different site altitudes and/or coolant temperatures

Site altitude above sea level	Coolant temperature in °C					
in m	<30	30-40	45	50	55	60
1000	1.07	1.00	0.96	0.92	0.87	0.82
1500	1.04	0.97	0.93	0.89	0.84	0.79
2000	1.00	0.94	0.9	0.86	0.82	0.77
2500	0.96	0.90	0.86	0.83	0.78	0.74
3000	0.92	0.86	0.82	0.79	0.75	0.70
3500	0.88	0.82	0.79	0.75	0.71	0.67
4000	0.82	0.77	0.74	0.71	0.67	0.63

Coolant temperature and site altitude are rounded up to 5 °C or 500 m.

##### Operation in the event of fire

In addition to normal duty, operation in the event of a fire as specified in EN 12101-3 is available.

At the end of the fire incident, the motor may be unfit for normal duty. **It is therefore specified that the motor is removed and overhauled or replaced with a new motor.**

In the event of a fire, any "thermal motor protection" must be deactivated.

##### Standard number of poles

- 2, 4 and 6
- For more poles and pole-changing motors, please inquire.

##### Insulation system

The special insulation systems are adapted to the respective temperature/time classes.

The insulation of the smoke extraction motors is designed such that converter-fed operation is possible without limitation at voltages  $\leq 460$  V. This also applies for operation with a pulse-controlled AC converter with voltage rise times  $t_s > 0.1 \mu s$  at the motor terminals.

**In the event of fire, the motors must be switched over from converter-fed operation to mains-fed operation. If converter-fed operation is also required in the event of fire, system testing and acceptance testing must be performed in accordance with this (please inquire).**

##### Drainage holes

Generally available, but closed if ordered according to IP55 degree of protection.

##### Bearing plates

All bearing plates are in cast-iron.

##### Termination system

Protruding cable with casing, without connection box with cover plate or "Nozzle cap". Cable length depends on the shaft height.

- Frame sizes 80 to 112: 1.0 m
- Frame sizes 132 to 200: 1.5 m
- Frame sizes 225 to 315: 2.5 m

Special versions of connecting cables are available on request.

##### Position of the connecting cable

- Frame sizes 80 to 160:
  - On the top at non-drive-end (NDE) as standard. Optionally left or right at non-drive-end (NDE) (for type of construction with screwed-on feet).
- Frame sizes 180 to 315:
  - Flange types of construction without feet:
    - On the top at non-drive-end (NDE) as standard. Optionally on left or right at non-drive-end (NDE).
  - All types of construction with feet:
    - On the top at drive-end (DE) as standard with connection cable routed towards the non-drive end (NDE). Optionally on left or right at drive-end (DE) with connection cable routed towards the non-drive-end (NDE) (for types of construction with screwed-on feet).

The equipment is earthed with a protruding cable.

### Technical specifications (continued)

#### Bearings, grease

Special bearing systems are used that are matched to the respective temperature classes.

Deep-groove bearings of series 60, 62 or 63 without play are used depending on the fire classes F200/F300, F400 and the frame sizes.

The located bearing is generally at the drive-end (DE).

The nominal bearing lifetime  $L_{10h}$  (fan drive) is at least 20,000 hours at full rated load.

The motors of frame sizes 80 to 250 generally have bearings that are greased for life.

#### Paint finish

The motors have a two-component finish (worldwide) as standard in the color RAL 7030.

#### Required minimum cooling air flow in standard duty

Frame size	1LA7/1PP7	1LA5/1PP5	1LA6/1PP6	Required cooling air flow for number of poles		
				2 m <sup>3</sup> /min.	4 m <sup>3</sup> /min.	6 m <sup>3</sup> /min.
80	X			1.74	0.90	0.60
90	X			3.12	1.56	1.08
100	X		X	3.96	1.86	1.26
112	X		X	4.98	3.00	1.98
132	X		X	8.04	5.04	3.36
160	X		X	12.90	9.54	6.36
180		X		10.98	10.98	7.27
200		X		15.12	13.02	8.58
225		X		12.12	13.02	8.58

Frame size	1LG6/1PP6	Required cooling air flow for number of poles		
		2 m <sup>3</sup> /min.	4 m <sup>3</sup> /min.	6 m <sup>3</sup> /min.
180	X	12.0	13.0	8.5
200	X	20.5	17.0	11.0
225	X	20.5	18.5	12.5
250	X	25.5	22.5	17.0
280	X	24.5	28.0	21.5
315	X	47	36.0	26.5

In the motor version without an integrated fan (1PP5, 1PP6 and 1PP7), the motor is located in the air flow of the ventilator to be driven which must drive the minimum cooling air flow over the motor housing. For a faster air flow, the operating temperature of the motor can be reduced.

#### Admissible loading on the shaft extension

The values specified in the table "Admissible loading on shaft extension" are the tested and approved maximum values (test duration two hours, temperature in case of fire 300 or 400 °C).

In standard duty at coolant temperatures of up to 40 °C, a bearing lifetime  $L_{10h} > 20000$  hours was achieved.

The values apply to all horizontal mounting positions and to all vertical mounting positions with shaft pointing downwards.

Please inquire in the case of :

- Higher force pairings
- Motors with more poles or pole-changing motors
- Vertical arrangement, depending on the rotor mass and mounting location (shaft pointing downwards or shaft pointing upwards) of the smoke-extraction motor. If necessary, higher forces can be approved.

# IEC Squirrel-Cage Motors

## Smoke-extraction motors

### Orientation

#### Technical specifications (continued)

##### Admissible loading in the event of a fault (fire) on the shaft extension (continued)

Frame size	Bearings	Type of loading on shaft	Horizontal shaft						Shaft pointing vertically downwards					
			2-pole		4-pole		6-pole		2-pole		4-pole		6-pole	
	DE	No.	$F_R$ N	$F_{A \text{ tens}}$ N	$F_R$ N	$F_{A \text{ tens}}$ N	$F_R$ N	$F_{A \text{ tens}}$ N	$F_R$ N	$F_{A \text{ tens}}$ N	$F_R$ N	$F_{A \text{ tens}}$ N	$F_R$ N	$F_{A \text{ tens}}$ N
80	6004	1 Radial force	400	0	490	0	540	0	360	0	450	0	540	0
		2 Radial force + axial tensile force	150	130	170	170	190	200	40	172	40	225	40	275
		3 Axial tensile force	0	215	0	265	0	320	0	197	0	250	0	300
90	6205	1 Radial force	650	0	730	0	795	0	590	0	730	0	795	0
		2 Radial force + axial tensile force	250	205	280	260	310	305	100	259	100	330	100	390
		3 Axial tensile force	0	343	0	415	0	480	0	310	0	384	0	450
100	6206	1 Radial force	890	0	1000	0	1080	0	820	0	1000	0	1080	0
		2 Radial force + axial tensile force	400	265	500	325	600	345	300	265	300	385	300	455
		3 Axial tensile force	0	490	0	600	0	675	0	432	0	540	0	625
112	6206	1 Radial force	870	0	980	0	1055	0	760	0	970	0	1055	0
		2 Radial force + axial tensile force	400	252	500	310	600	330	250	260	250	380	250	450
		3 Axial tensile force	0	478	0	595	0	675	0	403	0	510	0	590
132	6208	1 Radial force	1070	0	1415	0	1530	0	810	0	1060	0	1220	0
		2 Radial force + axial tensile force	450	315	550	450	650	480	250	300	250	520	250	585
		3 Axial tensile force	0	580	0	775	0	850	0	450	0	640	0	820
160	6209	1 Radial force	1440	0	1630	0	1760	0	1210	0	1580	0	1780	0
		2 Radial force + axial tensile force	700	450	800	570	900	650	500	335	500	525	500	665
		3 Axial tensile force	0	824	0	1015	0	1140	0	620	0	790	0	920
180	6210	1 Radial force	1540	0	1750	0	1900	0	1020	0	1400	0	1670	0
		2 Radial force + axial tensile force	770	430	900	545	1000	630	550	218	550	420	550	575
		3 Axial tensile force	0	815	0	1040	0	1183	0	453	0	733	0	875
200	6212	1 Radial force	2050	0	2380	0	2620	0	1450	0	1700	0	2090	0
		2 Radial force + axial tensile force	1200	770	1350	970	1500	1075	500	460	500	750	500	1600
		3 Axial tensile force	0	1350	0	1650	0	1875	0	720	0	1040	0	1905
225	6213	1 Radial force	2460	0	2720	0	2970	0	1910	0	2450	0	2900	0
		2 Radial force + axial tensile force	1370	900	1500	1095	1700	1200	500	660	500	1000	500	1250
		3 Axial tensile force	0	1560	0	1910	0	2170	0	920	0	1290	0	1520
250	6215	1 Radial force	2770	0	3230	0	3500	0	1490	0	2230	0	2700	0
		2 Radial force + axial tensile force	1400	840	1600	1095	1800	1340	500	460	500	815	500	1080
		3 Axial tensile force	0	1500	0	1865	0	2130	0	710	0	1090	0	1375
280	6217 (2-pole), 6317 (4-, 6-pole)	1 Radial force	3180	0	5000	0	5500	0	3000	0	5600	0	6100	0
		2 Radial force + axial tensile force	1700	1820	2000	2000	2300	2200	600	1085	600	2300	600	2750
		3 Axial tensile force	0	2630	0	3050	0	3500	0	1380	0	2600	0	3100
315	6219 (2-pole), 6319 (4-, 6-pole)	1 Radial force	3470	0	5300	0	5900	0	1000	0	3600	0	3850	0
		2 Radial force + axial tensile force	1750	2200	2000	2170	2300	2530	200	363	1000	1150	1000	1610
		3 Axial tensile force	0	3000	0	3080	0	3560	0	463	0	1690	0	2100

**Note:** In the event of a fault (fire), the reduced loads provided above must be observed and ensured by appropriate measures in the ventilation system. The permitted loads in catalog part 0 from Page 0/66 must be observed for operation under standard condition (CT 40 °C).

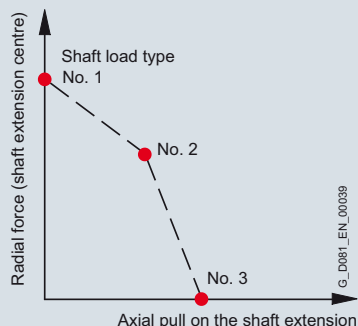

Load types

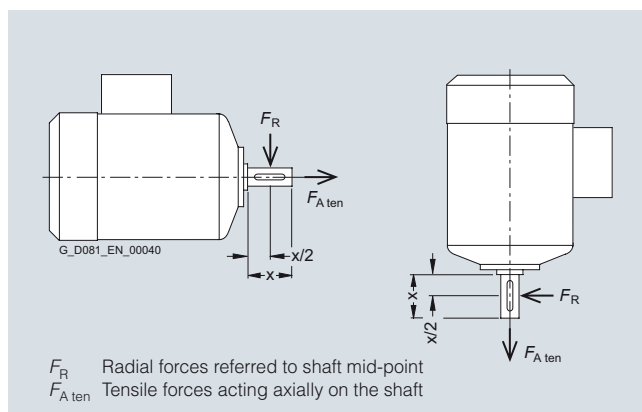

Forces on shaft extension

### Selection and ordering data

*Preliminary selection of the motor according to motor type/series, speed or number of poles, frame size, rated output, rated torque, rated speed and rated current*

Self-ventilated motors for temperature/time classes F200 and F300

Speed (No. of poles)	Frame size	Rated output	Rated speed	Rated torque	Rated current at 400 V	Detailed selection and ordering data Page
rpm		kW	rpm	Nm	A	
<b>Aluminum series 1LA7 and 1LA5, cast-iron series 1LG6 (motors with external fan)</b>						
<b>3000, 2-pole</b>	<b>80 M ... 315 L</b>	0.75 ... 200	2830 ... 2985	2.5 ... 640	2.1 ... 325	<b>9/8</b>
<b>1500, 4-pole</b>	<b>80 M ... 315 L</b>	0.55 ... 200	1395 ... 1488	3.7 ... 1284	1.86 ... 345	<b>9/8</b>
<b>1000, 6-pole</b>	<b>80 M ... 315 L</b>	0.37 ... 160	910 ... 990	3.9 ... 1543	1.2 ... 285	<b>9/10</b>
<b>1500/3000, 4/2-pole</b>	<b>80 M ... 160 L</b>	The electrical data can be calculated and supplied on receipt of order.				<b>9/12</b>
<b>1000/1500, 6/4-pole</b>	<b>80 M ... 200 L</b>					<b>9/12</b>
<b>750/1500, 8/4-pole</b>	<b>80 M ... 200 L</b>					<b>9/12</b>

Forced-air cooled motors for temperature/time classes F200 and F300

Speed (No. of poles)	Frame size	Rated output	Rated speed	Rated torque	Rated current at 400 V	Detailed selection and ordering data Page
rpm		kW	rpm	Nm	A	
<b>Aluminum series 1PP7 and 1PP5, cast-iron series 1PP6 (motors without an external fan)</b>						
<b>3000, 2-pole</b>	<b>80 M ... 315 L</b>	0.75 ... 200	2830 ... 2985	2.5 ... 640	2.1 ... 325	<b>9/14</b>
<b>1500, 4-pole</b>	<b>80 M ... 315 L</b>	0.55 ... 200	1395 ... 1488	3.7 ... 1284	1.86 ... 345	<b>9/14</b>
<b>1000, 6-pole</b>	<b>80 M ... 315 L</b>	0.37 ... 160	910 ... 990	3.9 ... 1543	1.2 ... 285	<b>9/16</b>
<b>1500/3000, 4/2-pole</b>	<b>80 M ... 160 L</b>	The electrical data can be calculated and supplied on receipt of order.				<b>9/18</b>
<b>1000/1500, 6/4-pole</b>	<b>80 M ... 200 L</b>					<b>9/18</b>
<b>750/1500, 8/4-pole</b>	<b>80 M ... 200 L</b>					<b>9/18</b>

Self-ventilated motors for temperature/time class F400

Speed (No. of poles)	Frame size	Rated output	Rated speed	Rated torque	Rated current at 400 V	Detailed selection and ordering data Page
rpm		kW	rpm	Nm	A	
<b>Cast-iron series 1LA6 and 1LG6 (motors with external fan)</b>						
<b>3000, 2-pole</b>	<b>100 L ... 315 L</b>	3 ... 190	2875 ... 2982	10 ... 608	6.5 ... 325	<b>9/20</b>
<b>1500, 4-pole</b>	<b>100 L ... 315 L</b>	2.2 ... 200	1410 ... 1490	15 ... 1284	5.5 ... 345	<b>9/20</b>
<b>1000, 6-pole</b>	<b>100 L ... 315 L</b>	1.5 ... 160	925 ... 990	15 ... 1546	4.5 ... 285	<b>9/22</b>
<b>1500/3000, 4/2-pole</b>	<b>100 L ... 160 L</b>	The electrical data can be calculated and supplied on receipt of order.				<b>9/24</b>
<b>1000/1500, 6/4-pole</b>	<b>100 L ... 160 L</b>					<b>9/24</b>
<b>750/1500, 8/4-pole</b>	<b>100 L ... 160 L</b>					<b>9/24</b>

Forced-air cooled motors for temperature/time class F400

Speed (No. of poles)	Frame size	Rated output	Rated speed	Rated torque	Rated current at 400 V	Detailed selection and ordering data Page
rpm		kW	rpm	Nm	A	
<b>Cast-iron series 1PP6 (motors without external fan)</b>						
<b>3000, 2-pole</b>	<b>100 L ... 315 L</b>	3 ... 190	2875 ... 2982	10 ... 608	6.5 ... 325	<b>9/26</b>
<b>1500, 4-pole</b>	<b>100 L ... 315 L</b>	2.2 ... 200	1410 ... 1490	15 ... 1284	5.5 ... 345	<b>9/26</b>
<b>1000, 6-pole</b>	<b>100 L ... 315 L</b>	1.5 ... 160	925 ... 990	15 ... 1546	4.5 ... 285	<b>9/28</b>
<b>1500/3000, 4/2-pole</b>	<b>100 L ... 160 M</b>	The electrical data can be calculated and supplied on receipt of order.				<b>9/30</b>
<b>1000/1500, 6/4-pole</b>	<b>100 L ... 160 L</b>					<b>9/30</b>
<b>750/1500, 8/4-pole</b>	<b>100 L ... 160 L</b>					<b>9/30</b>

### More information

For more information, please contact your local Siemens contact – see “Siemens Contacts Worldwide” in the Appendix.

# IEC Squirrel-Cage Motors

## Smoke-extraction motors

Self-ventilated, for temperature/time classes F200, F300 – Aluminum series 1LA7/5, cast-iron series 1LG6

### Selection and ordering data

Rated output at 50 Hz	Frame size	Operating values at rated output						Locked-rotor torque with direct starting as multiple of rated torque	Locked-rotor current	Break-down torque	Torque class	Moment of inertia	Order No. For Order No. supplements for voltage and type of construction, see table below	Price	Weight
		Rated speed at 50 Hz	Rated torque at 50 Hz	Efficiency at 50 Hz 4/4-load	Power factor at 50 Hz 4/4-load	Rated current at 50 Hz 400 V	$\cos\phi_{\text{rated}}$								
$P_{\text{rated}}$ kW	FS	$n_{\text{rated}}$ rpm	$T_{\text{rated}}$ Nm	$\eta_{\text{rated}}$ %	$\cos\phi_{\text{rated}}$	$I_{\text{rated}}$ A	$T_{\text{LR}}/T_{\text{rated}}$	$I_{\text{LR}}/I_{\text{rated}}$	$T_{\text{B}}/T_{\text{rated}}$	CL	$J$ kg m <sup>2</sup>				
<b>2-pole, 3000 rpm at 50 Hz, cooling method IC 411, IP55 degree of protection, with test certificate according to EN 12101-3</b>															
0.75	80 M	2830	2.5	63.0	0.83	2.1	2.3	5.6	2.4	16	0.00085	1LA7 080-2TAQQ		10.2	
1.1	80 M	2845	3.7	74.0	0.80	2.7	2.6	6.1	2.7	16	0.0011	1LA7 083-2TAQQ		11.9	
1.5	90 S	2860	5.0	73.0	0.80	3.7	2.4	5.5	2.7	16	0.0015	1LA7 090-2TAQQ		15.2	
2.2	90 L	2880	7.3	78.0	0.80	5.1	2.8	6.3	3.1	16	0.002	1LA7 096-2TAQQ		18	
3	100 L	2890	9.9	77.0	0.83	6.8	2.8	6.8	3.0	16	0.0038	1LA7 106-2TAQQ		24	
4	112 M	2905	13	82.0	0.83	8.5	2.6	7.2	2.9	16	0.0055	1LA7 113-2TAQQ		32	
5.5	132 S	2925	18	85.5	0.87	10.7	2.0	5.9	2.8	16	0.016	1LA7 130-2TAQQ		45	
7.5	132 S	2930	24	88.0	0.89	13.8	2.3	6.9	3.0	16	0.021	1LA7 131-2TAQQ		53	
11	160 M	2940	36	88.0	0.86	21	2.1	6.5	2.9	16	0.034	1LA7 163-2TAQQ		74	
15	160 M	2940	49	90.8	0.90	26.5	2.2	6.6	3.0	16	0.04	1LA7 164-2TAQQ		85	
18.5	160 L	2940	60	90.3	0.91	32.5	2.4	7.0	3.1	16	0.052	1LA7 166-2TAQQ		98	
22	180 M	2940	71	91.1	0.85	41	2.5	6.9	3.2	16	0.077	1LA5 183-2TAQQ		125	
30	200 L	2945	97	91.8	0.89	53	2.4	7.2	2.8	16	0.14	1LA5 206-2TAQQ		176	
37	200 L	2945	120	92.3	0.89	65	2.4	7.7	2.8	16	0.16	1LA5 207-2TAQQ		199	
45	225 M	2960	145	93.6	0.89	78	2.8	7.7	3.4	16	0.2	1LA5 223-2TAQQ		235	
55	250 M	2975	177	94.2	0.90	94	2.5	7.4	3.3	13	0.466	1LG6 253-2TBQQ		420	
75	280 S	2975	241	94.8	0.91	126	2.6	7.5	2.9	13	0.832	1LG6 280-2TBQQ		530	
90	280 M	2975	289	95.2	0.90	152	3.0	7.5	3.0	13	1.00	1LG6 283-2TBQQ		615	
110	315 S	2985	352	95.0	0.90	186	2.6	7.5	3.2	13	1.39	1LG6 310-2TBQQ		790	
132	315 M	2984	422	95.3	0.91	220	2.7	7.4	3.0	13	1.62	1LG6 313-2TBQQ		915	
160	315 L	2984	512	95.7	0.93	260	2.8	7.5	3.1	13	2.09	1LG6 316-2TBQQ		1055	
200	315 L	2984	640	95.9	0.93	325	2.5	7.0	2.8	13	2.46	1LG6 317-2TBQQ		1245	
<b>4-pole, 1500 rpm at 50 Hz, cooling method IC 411, IP55 degree of protection, with test certificate according to EN 12101-3</b>															
0.55	80 M	1395	3.7	57.0	0.75	1.85	2.2	3.9	2.2	16	0.0015	1LA7 080-4TAQQ		10	
0.75	80 M	1405	5.1	63.0	0.73	2.35	2.3	4.2	2.3	16	0.0018	1LA7 083-4TAQQ		11.4	
1.1	90 S	1415	7.4	68.0	0.74	3.15	2.3	4.6	2.4	16	0.0028	1LA7 090-4TAQQ		14.6	
1.5	90 L	1420	10	73.0	0.74	4.0	2.4	5.3	2.6	16	0.0035	1LA7 096-4TAQQ		17.9	
2.2	100 L	1420	15	75.0	0.78	5.4	2.5	5.6	2.8	16	0.0048	1LA7 106-4TAQQ		24	
3	100 L	1415	20	77.0	0.78	7.2	2.7	5.6	3.0	16	0.0058	1LA7 107-4TAQQ		27	
4	112 M	1440	27	78.0	0.78	9.2	2.7	6.5	3.0	16	0.011	1LA7 113-4TAQQ		34	
5.5	132 S	1450	36	88.5	0.78	12	2.5	6.3	3.1	16	0.018	1LA7 130-4TAQQ		47	
7.5	132 M	1455	49	84.0	0.78	16.5	2.7	6.7	3.2	16	0.024	1LA7 133-4TAQQ		53	
11	160 M	1455	72	89.0	0.81	23	2.2	6.2	2.7	16	0.04	1LA7 163-4TAQQ		73	
15	160 L	1460	98	84.5	0.80	32	2.6	6.5	3.0	16	0.052	1LA7 166-4TAQQ		98	
18.5	180 M	1460	121	86.5	0.79	39	2.3	7.5	3.0	16	0.13	1LA5 183-4TAQQ		125	
22	180 L	1475	144	88.0	0.78	46.5	2.3	7.5	3.0	16	0.15	1LA5 186-4TAQQ		139	
30	200 L	1465	196	89.0	0.81	60	2.6	7.0	3.2	16	0.24	1LA5 207-4TAQQ		184	
37	225 S	1470	241	92.1	0.84	69	2.8	7.0	3.2	16	0.32	1LA5 220-4TAQQ		230	
45	225 M	1470	293	92.2	0.87	80	2.8	7.7	3.3	16	0.36	1LA5 223-4TAQQ		256	
55	250 M	1485	354	94.7	0.86	97	2.9	7.5	3.3	16	0.856	1LG6 253-4TAQQ		460	
75	280 S	1486	482	94.6	0.87	132	2.6	7.3	2.8	16	1.40	1LG6 280-4TAQQ		575	
90	280 M	1485	579	94.6	0.88	156	2.5	7.3	2.8	16	1.70	1LG6 283-4TAQQ		675	
110	315 S	1488	706	95.0	0.87	192	2.6	6.9	2.8	16	2.31	1LG6 310-4TAQQ		810	
132	315 M	1488	847	95.3	0.87	230	2.7	7.0	2.7	16	2.88	1LG6 313-4TAQQ		965	
160	315 L	1488	1027	95.7	0.87	275	2.9	7.4	2.9	16	3.46	1LG6 316-4TAQQ		1105	
200	315 L	1488	1284	95.5	0.88	345	3.2	7.3	3.1	16	4.22	1LG6 317-4TAQQ		1305	

# IEC Squirrel-Cage Motors

## Smoke-extraction motors

Self-ventilated, for temperature/time classes F200, F300 – Aluminum series 1LA7/5, cast-iron series 1LG6

### Selection and ordering data (continued)

#### Order No. supplements

Motor type	Penultimate position: Voltage code				Final position: Type of construction code								
	50 Hz				Without flange	With flange				With standard flange		With special flange	
	230 VΔ/400 VY	400 VΔ/690 VY	500 VY	500 VΔ	IM B3/6/7/8, IM V6, IM V5 without protective cover <sup>1)</sup>	IM B5, IM V3 <sup>2)3)</sup>	IM V1 without protective cover <sup>2)3)</sup>	IM V1 with protective cover <sup>3)4)</sup>	IM B35	IM B14, IM V19, IM V18 without protective cover	IM B34	IM B14, IM V19, IM V18 without protective cover	
	1	6	3	5	0	1	1	8	4	6	2	7	3
1LA7 08 . . . . □□	○	○	○	–	□	✓	✓	–	✓	✓	✓	✓	✓
1LA7 09 . . . . □□	○	○	○	–	□	✓	✓	–	✓	✓	✓	✓	✓
1LA7 10 . . . . □□	○	○	○	○	□	✓	✓	–	✓	✓	✓	✓	✓
1LA7 11 . . . . □□	○	○	○	○	□	✓	✓	–	✓	✓	✓	✓	✓
1LA7 13 . . . . □□	○	○	○	○	□	✓	✓	–	✓	✓	✓	✓	✓
1LA7 16 . . . . □□	○	○	○	○	□	✓	✓	–	✓	✓	✓	✓	✓
1LA5 18 . . . . □□	○	○	○	○	□	✓ <sup>5)</sup>	✓	–	✓	✓	–	–	–
1LA5 20 . . . . □□	○	○	○	○	□	✓ <sup>5)</sup>	✓	–	✓	✓	–	–	–
1LA5 22 . . . . □□	○	○	○	○	□	✓ <sup>5)</sup>	✓	–	✓	✓	–	–	–
1LG6 25 . . . . □□	○	○	○	○	□	✓ <sup>5)</sup>	✓	–	✓	✓	–	–	–
1LG6 28 . . . . □□	○	○	○	○	□	✓ <sup>5)</sup>	✓	–	✓	✓	–	–	–
1LG6 310 . . . . □□	○	○	○	○	□	✓ <sup>5)</sup>	✓	–	✓	✓	–	–	–
1LG6 313 . . . . □□	○	○	○	○	□	✓ <sup>5)</sup>	✓	–	✓	✓	–	–	–
1LG6 316 . . . . □□	–	○	–	○	□ <sup>6)</sup>	–	–	✓	✓	✓	–	–	–
1LG6 317 . . . . □□	–	○	–	○	□ <sup>6)</sup>	–	–	✓	✓	✓	–	–	–

- Standard version
- Without additional charge
- ✓ With additional charge
- Not possible

Order other voltages with voltage code **9** in the penultimate position and with order code **L1Y** (see “Special versions” in the “Selection and ordering data” under “Voltages”).

Order other types of construction with type of construction code **9** in the final position and the corresponding order code (see “Special versions” in the “Selection and ordering data” under “Types of construction”).

- 1) If motors frame sizes 180 M to 315 L in types of construction with feet IM B6, IM B7, IM V6 or IM V5 without protective cover are fixed to the wall, it is recommended that the motor feet are supported.
- 2) 1LA5 183... to 1LA5 223... motors (motor series 1LA5, frame size 180 M to 225 M) can be supplied with two additional eyebolts; specify supplement “**Z**” and order code **K32**.
- 3) 1LG6 253... to 1LG6 317... motors (motor series 1LG6 frame sizes 250 M to 315 L) are supplied with two screw-in eyebolts in accordance with IM B5, whereby one can be rotated in accordance with IM V1 or IM V3. It is important to note that stress must not be applied perpendicular to the ring plane.

- 4) The “Second shaft extension” option, order code **K16** is not possible.
- 5) Type of construction IM V3 is only possible using type of construction code **9** and order code **M1G**.
- 6) Not possible for type of construction IM V6 and IM V5 without protective cover.

# IEC Squirrel-Cage Motors

## Smoke-extraction motors

Self-ventilated, for temperature/time classes F200, F300 – Aluminum series 1LA7/5, cast-iron series 1LG6

### Selection and ordering data (continued)

Rated output at 50 Hz	Frame size	Operating values at rated output						Locked-rotor torque with direct starting as multiple of rated torque	Locked-rotor current	Break-down torque	Torque class	Moment of inertia	Order No. For Order No. supplements for voltage and type of construction, see table below	Price	Weight
		Rated speed at 50 Hz	Rated torque at 50 Hz	Efficiency at 50 Hz 4/4-load	Power factor at 50 Hz 4/4-load	Rated current at 50 Hz 400 V	$T_{LR}/T_{rated}$								
$P_{rated}$ kW	FS	$n_{rated}$ rpm	$T_{rated}$ Nm	$\eta_{rated}$ %	$\cos\phi_{rated}$	$I_{rated}$ A				CL	$J$ kg m <sup>2</sup>				
<b>6-pole, 1000 rpm at 50 Hz, cooling method IC 411, IP55 degree of protection, with test certificate according to EN 12101-3</b>															
0.37	80 M	920	3.9	62.0	0.72	1.2	1.9	3.1	2.1	16	0.0015	<b>1LA7 080-6TAQQ</b>		9.5	
0.55	80 M	910	5.8	67.0	0.74	1.9	2.1	3.4	2.2	16	0.0018	<b>1LA7 083-6TAQQ</b>		11.4	
0.75	90 S	920	7.8	68.0	0.76	2.1	2.2	3.7	2.2	16	0.0028	<b>1LA7 090-6TAQQ</b>		14.8	
1.1	90 L	915	11.5	71.0	0.77	2.9	2.3	3.8	2.3	16	0.0035	<b>1LA7 096-6TAQQ</b>		18	
1.5	100 L	925	15	74.0	0.70	4.25	2.3	4	2.3	16	0.0063	<b>1LA7 106-6TAQQ</b>		26	
2.2	112 M	940	22	76.0	0.70	6.0	2.2	4.6	2.5	16	0.011	<b>1LA7 113-6TAQQ</b>		30	
3	132 S	950	30	72.0	0.76	7.2	1.9	4.2	2.2	16	0.015	<b>1LA7 130-6TAQQ</b>		45	
4	132 M	950	40	81.0	0.76	9.4	2.1	4.5	2.4	16	0.019	<b>1LA7 133-6TAQQ</b>		50	
5.5	132 M	950	55	70.0	0.74	15.4	2.3	5	2.6	16	0.025	<b>1LA7 134-6TAQQ</b>		58	
7.5	160 M	960	75	83.5	0.72	18	2.1	4.6	2.5	16	0.041	<b>1LA7 163-6TAQQ</b>		81	
11	160 L	960	109	87.5	0.71	25.5	2.3	4.8	2.6	16	0.049	<b>1LA7 166-6TAQQ</b>		107	
15	180 L	970	148	89.5	0.70	34.5	2.0	5.2	2.4	16	0.15	<b>1LA5 186-6TAQQ</b>		139	
18.5	200 L	975	181	90.1	0.71	42.5	2.7	5.5	2.8	16	0.24	<b>1LA5 206-6TAQQ</b>		184	
22	200 L	975	215	93.5	0.77	45.5	2.8	5.5	2.9	16	0.28	<b>1LA5 207-6TAQQ</b>		204	
30	225 M	978	294	92.2	0.68	71	2.8	5.7	2.9	16	0.36	<b>1LA5 223-6TAQQ</b>		246	
37	250 M	984	359	92.4	0.84	69	2.7	6.4	2.4	16	0.934	<b>1LG6 253-6TAQQ</b>		405	
45	280 S	986	436	92.7	0.86	81	2.5	6.6	2.5	16	1.40	<b>1LG6 280-6TAQQ</b>		520	
55	280 M	986	533	92.6	0.87	99	2.5	6.5	2.5	16	1.60	<b>1LG6 283-6TAQQ</b>		570	
75	315 S	990	723	93.8	0.85	136	2.7	7.0	2.9	16	2.50	<b>1LG6 310-6TAQQ</b>		760	
90	315 M	990	868	94.2	0.86	160	2.7	7.3	3.0	16	3.20	<b>1LG6 313-6TAQQ</b>		935	
110	315 L	990	1061	94.6	0.87	192	2.6	7.4	3.0	16	4.02	<b>1LG6 316-6TAQQ</b>		1010	
132	315 L	988	1276	94.7	0.87	230	3.0	7.2	2.8	16	4.71	<b>1LG6 317-6TAQQ</b>		1180	
160	315 L	990	1543	94.9	0.86	285	3.1	7.5	3.0	16	5.39	<b>1LG6 318-6TAQQ</b>		1245	



# IEC Squirrel-Cage Motors

## Smoke-extraction motors

Self-ventilated, for temperature/time classes F200, F300 – Aluminum series 1LA7/5, cast-iron series 1LG6

### Selection and ordering data (continued)

#### Order No. supplements

Motor type	Penultimate position: Voltage code				Final position: Type of construction code								
	50 Hz				Without flange	With flange					With standard flange	With special flange	
	230 VΔ/400 VY	400 VΔ/690 VY	500 VY	500 VΔ	IM B3/6/7/8, IM V6, IM V5 without protective cover <sup>1)</sup>	IM B5, IM V3 <sup>2)3)</sup>	IM V1 without protective cover <sup>2)3)</sup>	IM V1 with protective cover <sup>3)4)</sup>	IM B35	IM B14, IM V19, IM V18 without protective cover	IM B34	IM B14, IM V19, IM V18 without protective cover	
	1	6	3	5	0	1	1	8	4	6	2	7	3
1LA7 08 . . . . □□	○	○	○	–	□	✓	✓	–	✓	✓	✓	✓	✓
1LA7 09 . . . . □□	○	○	○	–	□	✓	✓	–	✓	✓	✓	✓	✓
1LA7 10 . . . . □□	○	○	○	○	□	✓	✓	–	✓	✓	✓	✓	✓
1LA7 11 . . . . □□	○	○	○	○	□	✓	✓	–	✓	✓	✓	✓	✓
1LA7 13 . . . . □□	○	○	○	○	□	✓	✓	–	✓	✓	✓	✓	✓
1LA7 16 . . . . □□	○	○	○	○	□	✓	✓	–	✓	✓	✓	✓	✓
1LA5 18 . . . . □□	○	○	○	○	□	✓ <sup>5)</sup>	✓	–	✓	✓	–	–	–
1LA5 20 . . . . □□	○	○	○	○	□	✓ <sup>5)</sup>	✓	–	✓	✓	–	–	–
1LA5 22 . . . . □□	○	○	○	○	□	✓ <sup>5)</sup>	✓	–	✓	✓	–	–	–
1LG6 25 . . . . □□	○	○	○	○	□	✓ <sup>5)</sup>	✓	–	✓	✓	–	–	–
1LG6 28 . . . . □□	○	○	○	○	□	✓ <sup>5)</sup>	✓	–	✓	✓	–	–	–
1LG6 310 . . . . □□	○	○	○	○	□	✓ <sup>5)</sup>	✓	–	✓	✓	–	–	–
1LG6 313 . . . . □□	○	○	○	○	□	✓ <sup>5)</sup>	✓	–	✓	✓	–	–	–
1LG6 316 . . . . □□	–	○	–	○	□ <sup>6)</sup>	–	–	✓	✓	✓	–	–	–
1LG6 317 . . . . □□													
1LG6 318 . . . . □□													

- Standard version
- Without additional charge
- ✓ With additional charge
- Not possible

Order other voltages with voltage code **9** in the penultimate position and with order code **L1Y** (see “Special versions” in the “Selection and ordering data” under “Voltages”).

Order other types of construction with type of construction code **9** in the final position and the corresponding order code (see “Special versions” in the “Selection and ordering data” under “Types of construction”).

- 1) If motors frame sizes 180 M to 315 L in types of construction with feet IM B6, IM B7, IM V6 or IM V5 without protective cover are fixed to the wall, it is recommended that the motor feet are supported.
- 2) 1LA5 183-... to 1LA5 223-... motors (motor series 1LA5, frame size 180 M to 225 M) can be supplied with two additional eyebolts; specify supplement “**Z**” and order code **K32**.
- 3) 1LG6 253-... to 1LG6 318-... motors (motor series 1LG6 frame sizes 250 M to 315 L) are supplied with two screw-in eyebolts in accordance with IM B5, whereby one can be rotated in accordance with IM V1 or IM V3. It is important to note that stress must not be applied perpendicular to the ring plane.

- 4) The “Second shaft extension” option, order code **K16** is not possible.
- 5) Type of construction IM V3 is only possible using type of construction code **9** and order code **M1G**.
- 6) Not possible for type of construction IM V6 and IM V5 without protective cover.

# IEC Squirrel-Cage Motors

## Smoke-extraction motors

Self-ventilated, for temperature/time classes F200, F300 – Aluminum series 1LA7/5, cast-iron series 1LG6

### Selection and ordering data (continued)

Rated output at 50 Hz		Frame size	Order No.	Price	Weight for type of construction IM B3 approx.  <i>m</i> kg
1500 rpm	3000 rpm				
$P_{\text{rated}}$ kW	$P_{\text{rated}}$ kW	FS	For Order No. supplements for voltage and type of construction, see table below		
<b>4/2-pole, 1500/3000 rpm at 50 Hz, cooling method IC 411, IP55 degree of protection, double pole-changing for driving smoke-extraction fans with one winding in Dahlander circuit, with test certificate in accordance with EN 12101-3</b>					
0.14	0.63	80 M	<b>1LA7 080-0TAQQ</b>		11.0
0.23	0.86	80 M	<b>1LA7 083-0TAQQ</b>		12.4
0.3	1.26	90 S	<b>1LA7 090-0TAQQ</b>		14.6
0.45	1.8	90 L	<b>1LA7 096-0TAQQ</b>		17.9
0.59	2.25	100 L	<b>1LA7 106-0TAQQ</b>		24.0
0.72	2.8	100 L	<b>1LA7 107-0TAQQ</b>		27.0
0.99	3.95	112 M	<b>1LA7 113-0TAQQ</b>		34.0
1.3	5.3	132 S	<b>1LA7 130-0TAQQ</b>		47.0
1.8	7.2	132 M	<b>1LA7 133-0TAQQ</b>		53.0
2.6	10.4	160 M	<b>1LA7 163-0TAQQ</b>		74.0
3.85	15.3	160 L	<b>1LA7 166-0TAQQ</b>		105.0
Rated output at 50 Hz					
1000 rpm	1500 rpm				
$P_{\text{rated}}$ kW	$P_{\text{rated}}$ kW				
<b>6/4-pole, 1000/1500 rpm at 50 Hz, cooling method IC 411, IP55 degree of protection, double pole-changing for driving smoke-extraction fans with two windings, with test certificate in accordance with EN 12101-3</b>					
0.11	0.36	80 M	<b>1LA7 080-1TDQQ</b>		10.0
0.16	0.5	80 M	<b>1LA7 083-1TDQQ</b>		11.4
0.26	0.72	90 S	<b>1LA7 090-1TDQQ</b>		14.6
0.34	0.99	90 L	<b>1LA7 096-1TDQQ</b>		17.9
0.54	1.53	100 L	<b>1LA7 106-1TDQQ</b>		24.0
0.68	1.89	100 L	<b>1LA7 107-1TDQQ</b>		27.0
0.81	2.7	112 M	<b>1LA7 113-1TDQQ</b>		34.0
1.08	3.5	132 S	<b>1LA7 130-1TDQQ</b>		47.0
1.53	4.85	132 M	<b>1LA7 133-1TDQQ</b>		53.0
2.25	6.5	160 M	<b>1LA7 163-1TDQQ</b>		73.0
3.35	10.8	160 L	<b>1LA7 166-1TDQQ</b>		98.0
4.95	14.4	180 M	<b>1LA5 183-1TDQQ</b>		125.0
5.9	17.1	180 L	<b>1LA5 186-1TDQQ</b>		139.0
8.6	23.5	200 L	<b>1LA5 207-1TDQQ</b>		184.0
Rated output at 50 Hz					
750 rpm	1500 rpm				
$P_{\text{rated}}$ kW	$P_{\text{rated}}$ kW				
<b>8/4-pole, 750/1500 rpm at 50 Hz, cooling method IC 411, IP55 degree of protection, double pole-changing for driving smoke-extraction fans with one winding in Dahlander circuit, with test certificate in accordance with EN 12101-3</b>					
0.09	0.45	80 M	<b>1LA7 080-0TBQQ</b>		10.0
0.14	0.63	80 M	<b>1LA7 083-0TBQQ</b>		11.4
0.2	0.9	90 S	<b>1LA7 090-0TBQQ</b>		14.6
0.3	1.35	90 L	<b>1LA7 096-0TBQQ</b>		17.9
0.45	1.8	100 L	<b>1LA7 106-0TBQQ</b>		24.0
0.59	2.25	100 L	<b>1LA7 107-0TBQQ</b>		27.0
0.81	3.25	112 M	<b>1LA7 113-0TBQQ</b>		34.0
0.99	4.25	132 S	<b>1LA7 130-0TBQQ</b>		47.0
1.26	5.8	132 M	<b>1LA7 133-0TBQQ</b>		53.0
1.98	8.6	160 M	<b>1LA7 163-0TBQQ</b>		73.0
3	12.6	160 L	<b>1LA7 166-0TBQQ</b>		98.0
4.05	14.4	180 M	<b>1LA5 183-0TBQQ</b>		125.0
4.5	16.7	180 L	<b>1LA5 186-0TBQQ</b>		139.0
6.8	25	200 L	<b>1LA5 207-0TBQQ</b>		184.0

The rated outputs and weights may change slightly after they have been checked.

Further electrical data can be calculated and supplied on receipt of order.

# IEC Squirrel-Cage Motors

## Smoke-extraction motors

Self-ventilated, for temperature/time classes F200, F300 – Aluminum series 1LA7/5, cast-iron series 1LG6

### Selection and ordering data (continued)

#### Order No. supplements

Motor type	Penultimate position: Voltage code			Final position: Type of construction code								
	50 Hz, direct online starting			Without flange	With flange				With standard flange			With special flange
	230 V	400 V	500 V	IM B3/6/7/8, IM V6, IM V5 without protective cover	IM B5, IM V3 <sup>1)</sup>	IM V1 without protective cover <sup>1)</sup>	IM V1 with protective cover <sup>1) 2)</sup>	IM B35	IM B14, IM V19/18 without protective cover	IM B34	IM B14 IM V19/18 without protective cover	
	1	6	5	0	1	1	8	4	6	2	7	3
1LA7 08 .-. . . . □□	○	○	○	□	✓	✓	–	✓	✓	✓	✓	✓
1LA7 09 .-. . . . □□	○	○	○	□	✓	✓	–	✓	✓	✓	✓	✓
1LA7 10 .-. . . . □□	○	○	○	□	✓	✓	–	✓	✓	✓	✓	✓
1LA7 11 .-. . . . □□	○	○	○	□	✓	✓	–	✓	✓	✓	✓	✓
1LA7 13 .-. . . . □□	○	○	○	□	✓	✓	–	✓	✓	✓	✓	✓
1LA7 16 .-. . . . □□	○	○	○	□	✓	✓	–	✓	✓	✓	✓	✓
1LA5 18 .-. . . . □□	○	○	○	□	✓ <sup>3)</sup>	✓	–	✓	✓	–	–	–
1LA5 20 .-. . . . □□	○	○	○	□	✓ <sup>3)</sup>	✓	–	✓	✓	–	–	–

- Standard version
- Without additional charge
- ✓ With additional charge
- Not possible

Order other voltages with voltage code **9** in the penultimate position and with order code **L1Y** (see “Special versions” in the “Selection and ordering data” under “Voltages”).

Order other types of construction with type of construction code **9** in the final position and the corresponding order code (see “Special versions” in the “Selection and ordering data” under “Types of construction”).

- <sup>1)</sup> 1LA5 183... to 1LA5 223... motors (motor series 1LA5, frame size 180 M to 225 M) can be supplied with two additional eyebolts; specify supplement “**Z**” and order code **K32**.
- <sup>2)</sup> The “Second shaft extension” option, order code **K16** is not possible.
- <sup>3)</sup> Type of construction IM V3 is only possible using type of construction code **9** and order code **M1G**.

# IEC Squirrel-Cage Motors

## Smoke-extraction motors

Forced-air cooled, for temperature/time classes F200, F300 – Aluminum series 1PP7/5, cast-iron series 1PP6

### Selection and ordering data

Rated output at 50 Hz	Frame size	Operating values at rated output						Locked-rotor torque with direct starting as multiple of rated torque	Locked-rotor current	Break-down torque	Torque class	Moment of inertia	Order No. For Order No. supplements for voltage and type of construction, see table below	Price	Weight
		Rated speed at 50 Hz	Rated torque at 50 Hz	Efficiency at 50 Hz 4/4-load	Power factor at 50 Hz 4/4-load	Rated current at 50 Hz 400 V	$\cos\phi_{\text{rated}}$								
$P_{\text{rated}}$ kW	FS	$n_{\text{rated}}$ rpm	$T_{\text{rated}}$ Nm	$\eta_{\text{rated}}$ %	$\cos\phi_{\text{rated}}$	$I_{\text{rated}}$ A	$T_{\text{LR}}/T_{\text{rated}}$	$I_{\text{LR}}/I_{\text{rated}}$	$T_{\text{B}}/T_{\text{rated}}$	CL	$J$ kg m <sup>2</sup>			$m$ kg	
<b>2-pole, 3000 rpm at 50 Hz, cooling method IC 411, IP55 degree of protection, with test certificate according to EN 12101-3</b>															
0.75	80 M	2830	2.5	63.0	0.83	2.1	2.3	5.6	2.4	16	0.00085	1PP7 080-2TAQQ		9.8	
1.1	80 M	2845	3.7	74.0	0.80	2.7	2.6	6.1	2.7	16	0.0011	1PP7 083-2TAQQ		11.5	
1.5	90 S	2860	5.0	73.0	0.80	3.7	2.4	5.5	2.7	16	0.0015	1PP7 090-2TAQQ		14.6	
2.2	90 L	2880	7.3	78.0	0.80	5.1	2.8	6.3	3.1	16	0.002	1PP7 096-2TAQQ		17.4	
3	100 L	2890	9.9	77.0	0.83	6.8	2.8	6.8	3.0	16	0.0038	1PP7 106-2TAQQ		23	
4	112 M	2905	13	82.0	0.83	8.5	2.6	7.2	2.9	16	0.0055	1PP7 113-2TAQQ		31	
5.5	132 S	2925	18	85.5	0.87	10.7	2.0	5.9	2.8	16	0.016	1PP7 130-2TAQQ		44	
7.5	132 S	2930	24	88.0	0.89	13.8	2.3	6.9	3.0	16	0.021	1PP7 131-2TAQQ		52	
11	160 M	2940	36	88.0	0.86	21	2.1	6.5	2.9	16	0.034	1PP7 163-2TAQQ		71	
15	160 M	2940	49	90.8	0.90	26.5	2.2	6.6	3.0	16	0.04	1PP7 164-2TAQQ		82	
18.5	160 L	2940	60	90.3	0.91	32.5	2.4	7.0	3.1	16	0.052	1PP7 166-2TAQQ		95	
22	180 M	2940	71	91.1	0.85	41	2.5	6.9	3.2	16	0.077	1PP5 183-2TAQQ		119	
30	200 L	2945	97	91.8	0.89	53	2.4	7.2	2.8	16	0.14	1PP5 206-2TAQQ		168	
37	200 L	2945	120	92.3	0.89	65	2.4	7.7	2.8	16	0.16	1PP5 207-2TAQQ		191	
45	225 M	2960	145	93.6	0.89	78	2.8	7.7	3.4	16	0.2	1PP5 223-2TAQQ		226	
55	250 M	2975	177	95.1	0.90	94	2.5	7.4	3.3	13	0.466	1PP6 253-2TBQQ		405	
75	280 S	2975	241	95.3	0.91	126	2.6	7.5	2.9	13	0.832	1PP6 280-2TBQQ		510	
90	280 M	2975	289	95.6	0.90	152	3.0	7.5	3.0	13	1.00	1PP6 283-2TBQQ		595	
110	315 S	2985	352	95.9	0.90	186	2.6	7.5	3.2	13	1.39	1PP6 310-2TBQQ		770	
132	315 M	2984	422	96.1	0.91	220	2.7	7.4	3.0	13	1.62	1PP6 313-2TBQQ		895	
160	315 L	2984	512	96.3	0.93	260	2.8	7.5	3.1	13	2.09	1PP6 316-2TBQQ		1035	
200	315 L	2984	640	96.4	0.93	325	2.5	7.0	2.8	13	2.46	1PP6 317-2TBQQ		1225	
<b>4-pole, 1500 rpm at 50 Hz, cooling method IC 411, IP55 degree of protection, with test certificate according to EN 12101-3</b>															
0.55	80 M	1395	3.7	57.0	0.75	1.85	2.2	3.9	2.2	16	0.0015	1PP7 080-4TAQQ		9.6	
0.75	80 M	1405	5.1	63.0	0.73	2.35	2.3	4.2	2.3	16	0.0018	1PP7 083-4TAQQ		11	
1.1	90 S	1415	7.4	68.0	0.74	3.15	2.3	4.6	2.4	16	0.0028	1PP7 090-4TAQQ		14	
1.5	90 L	1420	10	73.0	0.74	4.0	2.4	5.3	2.6	16	0.0035	1PP7 096-4TAQQ		17.3	
2.2	100 L	1420	15	75.0	0.78	5.4	2.5	5.6	2.8	16	0.0048	1PP7 106-4TAQQ		23	
3	100 L	1415	20	77.0	0.78	7.2	2.7	5.6	3.0	16	0.0058	1PP7 107-4TAQQ		26	
4	112 M	1440	27	78.0	0.78	9.2	2.7	6.5	3.0	16	0.011	1PP7 113-4TAQQ		33	
5.5	132 S	1450	36	88.5	0.78	12	2.5	6.3	3.1	16	0.018	1PP7 130-4TAQQ		46	
7.5	132 M	1455	49	84.0	0.78	16.5	2.7	6.7	3.2	16	0.024	1PP7 133-4TAQQ		52	
11	160 M	1455	72	89.0	0.81	23	2.2	6.2	2.7	16	0.04	1PP7 163-4TAQQ		70	
15	160 L	1460	98	84.5	0.80	32	2.6	6.5	3.0	16	0.052	1PP7 166-4TAQQ		95	
18.5	180 M	1460	121	86.5	0.79	39	2.3	7.5	3.0	16	0.13	1PP5 183-4TAQQ		116	
22	180 L	1475	144	88.0	0.78	46.5	2.3	7.5	3.0	16	0.15	1PP5 186-4TAQQ		130	
30	200 L	1465	196	89.0	0.81	60	2.6	7.0	3.2	16	0.24	1PP5 207-4TAQQ		173	
37	225 S	1470	241	92.1	0.84	69	2.8	7.0	3.2	16	0.32	1PP5 220-4TAQQ		218	
45	225 M	1470	293	92.2	0.87	80	2.8	7.7	3.3	16	0.36	1PP5 223-4TAQQ		244	
55	250 M	1485	354	94.9	0.86	97	2.9	7.5	3.3	16	0.856	1PP6 253-4TAQQ		445	
75	280 S	1486	482	95.0	0.87	132	2.6	7.3	2.8	16	1.39	1PP6 280-4TAQQ		555	
90	280 M	1485	579	94.9	0.88	156	2.5	7.3	2.8	16	1.71	1PP6 283-4TAQQ		655	
110	315 S	1488	706	95.3	0.87	192	2.6	6.9	2.8	16	2.31	1PP6 310-4TAQQ		790	
132	315 M	1488	847	95.5	0.87	230	2.7	7.0	2.7	16	2.88	1PP6 313-4TAQQ		945	
160	315 L	1488	1027	95.9	0.87	275	2.9	7.4	2.9	16	3.46	1PP6 316-4TAQQ		1085	
200	315 L	1488	1284	95.7	0.88	345	3.2	7.3	3.1	16	4.22	1PP6 317-4TAQQ		1285	

# IEC Squirrel-Cage Motors

## Smoke-extraction motors

Forced-air cooled, for temperature/time classes F200, F300 – Aluminum series 1PP7/5, cast-iron series 1PP6

### Selection and ordering data (continued)

#### Order No. supplements

Motor type	Penultimate position: Voltage code				Final position: Type of construction code							
	50 Hz				Without flange	With flange			With standard flange	With special flange		
	230 VΔ/ 400 VY	400 VΔ/ 690 VY	500 VY	500 VΔ	IM B3/6/7/8, IM V6/5 without protective cover <sup>1)</sup>	IM B5, IM V3 <sup>2) 3)</sup>	IM V1 without protective cover <sup>2)</sup>	IM B35	IM B14, IM V19/18 without protective cover	IM B34	IM B14, IM V19/18 without protective cover	
	1	6	3	5	0	1	1	8	6	2	7	3
1PP7 08 . . . . □□	○	○	○	–	□	✓	✓	–	✓	✓	✓	✓
1PP7 09 . . . . □□	○	○	○	–	□	✓	✓	–	✓	✓	✓	✓
1PP7 10 . . . . □□	○	○	○	○	□	✓	✓	–	✓	✓	✓	✓
1PP7 11 . . . . □□	○	○	○	○	□	✓	✓	–	✓	✓	✓	✓
1PP7 13 . . . . □□	○	○	○	○	□	✓	✓	–	✓	✓	✓	✓
1PP7 16 . . . . □□	○	○	○	○	□	✓	✓	–	✓	✓	✓	✓
1PP5 18 . . . . □□	○	○	○	○	□	✓ <sup>4)</sup>	✓	–	✓	–	–	–
1PP5 20 . . . . □□	○	○	○	○	□	✓ <sup>4)</sup>	✓	–	✓	–	–	–
1PP5 22 . . . . □□	○	○	○	○	□	✓ <sup>4)</sup>	✓	–	✓	–	–	–
1PP6 25 . . . . □□	○	○	○	○	□	✓ <sup>4)</sup>	✓	–	✓	–	–	–
1PP6 28 . . . . □□	○	○	○	○	□	✓ <sup>4)</sup>	✓	–	✓	–	–	–
1PP6 310 . . . . □□	○	○	○	○	□	✓ <sup>4)</sup>	✓	–	✓	–	–	–
1PP6 313 . . . . □□	○	○	○	○	□	✓ <sup>4)</sup>	✓	–	✓	–	–	–
1PP6 316 . . . . □□	–	○	–	○	□ <sup>5)</sup>	–	–	✓	✓	–	–	–
1PP6 317 . . . . □□	–	○	–	○	□ <sup>5)</sup>	–	–	✓	✓	–	–	–

- Standard version
- Without additional charge
- ✓ With additional charge
- Not possible

Order other voltages with voltage code **9** in the penultimate position and with order code **L1Y** (see “Special versions” in the “Selection and ordering data” under “Voltages”).

Order other types of construction with type of construction code **9** in the final position and the corresponding order code (see “Special versions” in the “Selection and ordering data” under “Types of construction”).

<sup>1)</sup> If motors frame sizes 180 M to 315 L in types of construction with feet IM B6, IM B7, IM V6 or IM V5 without protective cover are fixed to the wall, it is recommended that the motor feet are supported.

<sup>2)</sup> 1PP5 183-... to 1PP5 223-... motors (motor series 1PP5, frame size 180 M to 225 M) can be supplied with two additional eyebolts; specify supplement “**Z**” and order code **K32**.

<sup>3)</sup> 1PP6 253-... to 1PP6 318-... motors (motor series 1PP6 frame sizes 250 M to 315 L) are supplied with two screw-in eyebolts in accordance with IM B5, whereby one can be rotated in accordance with IM V1 or IM V3. It is important to note that stress must not be applied perpendicular to the ring plane.

<sup>4)</sup> Type of construction IM V3 is only possible using type of construction code **9** and order code **M1G**.

<sup>5)</sup> Not possible for type of construction IM V6 and IM V5 without protective cover.

# IEC Squirrel-Cage Motors

## Smoke-extraction motors

Forced-air cooled, for temperature/time classes F200, F300 – Aluminum series 1PP7/5, cast-iron series 1PP6

### Selection and ordering data (continued)

Rated output at 50 Hz	Frame size	Operating values at rated output						Locked-rotor torque with direct starting as multiple of rated torque	Locked-rotor current	Break-down torque	Torque class	Moment of inertia	Order No. For Order No. supplements for voltage and type of construction, see table below	Price	Weight
		Rated speed at 50 Hz	Rated torque at 50 Hz	Efficiency at 50 Hz 4/4-load	Power factor at 50 Hz 4/4-load	Rated current at 50 Hz 400 V	$T_{LR}/T_{rated}$								
$P_{rated}$ kW	FS	$n_{rated}$ rpm	$T_{rated}$ Nm	$\eta_{rated}$ %	$\cos\phi_{rated}$	$I_{rated}$ A	$T_{LR}/T_{rated}$	$I_{LR}/I_{rated}$	$T_B/T_{rated}$	CL	$J$ kg m <sup>2</sup>			$m$ kg	
<b>6-pole, 1000 rpm at 50 Hz, cooling method IC 411, IP55 degree of protection, with test certificate according to EN 12101-3</b>															
0.37	80 M	920	3.9	62.0	0.72	1.2	1.9	3.1	2.1	16	0.0015	<b>1PP7 080-6TAQQ</b>		9.6	
0.55	80 M	910	5.8	67.0	0.74	1.9	2.1	3.4	2.2	16	0.0018	<b>1PP7 083-6TAQQ</b>		11	
0.75	90 S	920	7.8	68.0	0.76	2.1	2.2	3.7	2.2	16	0.0028	<b>1PP7 090-6TAQQ</b>		14.2	
1.1	90 L	915	11.5	71.0	0.77	2.9	2.3	3.8	2.3	16	0.0035	<b>1PP7 096-6TAQQ</b>		17.4	
1.5	100 L	925	15	74.0	0.70	4.25	2.3	4	2.3	16	0.0063	<b>1PP7 106-6TAQQ</b>		25	
2.2	112 M	940	22	76.0	0.70	6.0	2.2	4.6	2.5	16	0.011	<b>1PP7 113-6TAQQ</b>		29	
3	132 S	950	30	72.0	0.76	7.2	1.9	4.2	2.2	16	0.015	<b>1PP7 130-6TAQQ</b>		44	
4	132 M	950	40	81.0	0.76	9.4	2.1	4.5	2.4	16	0.019	<b>1PP7 133-6TAQQ</b>		49	
5.5	132 M	950	55	70.0	0.74	15.4	2.3	5	2.6	16	0.025	<b>1PP7 134-6TAQQ</b>		57	
7.5	160 M	960	75	83.5	0.72	18	2.1	4.6	2.5	16	0.041	<b>1PP7 163-6TAQQ</b>		78	
11	160 L	960	109	87.5	0.71	25.5	2.3	4.8	2.6	16	0.049	<b>1PP7 166-6TAQQ</b>		104	
15	180 L	970	148	89.5	0.70	34.5	2.0	5.2	2.4	16	0.15	<b>1PP5 186-6TAQQ</b>		130	
18.5	200 L	975	181	90.1	0.71	42.5	2.7	5.5	2.8	16	0.24	<b>1PP5 206-6TAQQ</b>		173	
22	200 L	975	215	93.5	0.77	45.5	2.8	5.5	2.9	16	0.28	<b>1PP5 207-6TAQQ</b>		193	
30	225 M	978	294	92.2	0.68	71	2.8	5.7	2.9	16	0.36	<b>1PP5 223-6TAQQ</b>		234	
37	250 M	984	359	92.6	0.84	69	2.7	6.4	2.4	16	0.934	<b>1PP6 253-6TAQQ</b>		390	
45	280 S	986	436	92.8	0.86	81	2.5	6.6	2.5	16	1.37	<b>1PP6 280-6TAQQ</b>		500	
55	280 M	986	533	92.7	0.87	99	2.5	6.5	2.5	16	1.65	<b>1PP6 283-6TAQQ</b>		550	
75	315 S	990	723	93.9	0.85	136	2.7	7.0	2.9	16	2.50	<b>1PP6 310-6TAQQ</b>		740	
90	315 M	990	868	94.3	0.86	160	2.7	7.3	3.0	16	3.20	<b>1PP6 313-6TAQQ</b>		915	
110	315 L	990	1061	94.7	0.87	192	2.6	7.4	3.0	16	4.02	<b>1PP6 316-6TAQQ</b>		990	
132	315 L	988	1276	94.8	0.87	230	3.0	7.2	2.8	16	4.71	<b>1PP6 317-6TAQQ</b>		1160	
160	315 L	990	1543	95.0	0.86	285	3.1	7.5	3.0	16	5.39	<b>1PP6 318-6TAQQ</b>		1225	

# IEC Squirrel-Cage Motors

## Smoke-extraction motors

Forced-air cooled, for temperature/time classes F200, F300 – Aluminum series 1PP7/5, cast-iron series 1PP6

### Selection and ordering data (continued)

#### Order No. supplements

Motor type	Penultimate position: Voltage code				Final position: Type of construction code							
	50 Hz				Without flange	With flange			With standard flange	With special flange		
	230 VΔ/ 400 VY	400 VΔ/ 690 VY	500 VY	500 VΔ	IM B3/6/7/8, IM V6/5 without protective cover <sup>1)</sup>	IM B5, IM V3 <sup>2) 3)</sup>	IM V1 without protective cover <sup>2)</sup>	IM B35	IM B14, IM V19/18 without protective cover	IM B34	IM B14, IM V19/18 without protective cover	
1	6	3	5	0	1	1	8	6	2	7	3	
1PP7 08 . . . . □□	○	○	○	–	□	✓	✓	–	✓	✓	✓	✓
1PP7 09 . . . . □□	○	○	○	–	□	✓	✓	–	✓	✓	✓	✓
1PP7 10 . . . . □□	○	○	○	○	□	✓	✓	–	✓	✓	✓	✓
1PP7 11 . . . . □□	○	○	○	○	□	✓	✓	–	✓	✓	✓	✓
1PP7 13 . . . . □□	○	○	○	○	□	✓	✓	–	✓	✓	✓	✓
1PP7 16 . . . . □□	○	○	○	○	□	✓	✓	–	✓	✓	✓	✓
1PP5 18 . . . . □□	○	○	○	○	□	✓ <sup>4)</sup>	✓	–	✓	–	–	–
1PP5 20 . . . . □□	○	○	○	○	□	✓ <sup>4)</sup>	✓	–	✓	–	–	–
1PP5 22 . . . . □□	○	○	○	○	□	✓ <sup>4)</sup>	✓	–	✓	–	–	–
1PP6 25 . . . . □□	○	○	○	○	□	✓ <sup>4)</sup>	✓	–	✓	–	–	–
1PP6 28 . . . . □□	○	○	○	○	□	✓ <sup>4)</sup>	✓	–	✓	–	–	–
1PP6 310 . . . . □□	○	○	○	○	□	✓ <sup>4)</sup>	✓	–	✓	–	–	–
1PP6 313 . . . . □□	○	○	○	○	□	✓ <sup>4)</sup>	✓	–	✓	–	–	–
1PP6 316 . . . . □□	–	○	–	○	□ <sup>5)</sup>	–	–	✓	✓	–	–	–
1PP6 317 . . . . □□	–	○	–	○	□ <sup>5)</sup>	–	–	✓	✓	–	–	–
1PP6 318 . . . . □□	–	○	–	○	□ <sup>5)</sup>	–	–	✓	✓	–	–	–

- Standard version
- Without additional charge
- ✓ With additional charge
- Not possible

Order other voltages with voltage code **9** in the penultimate position and with order code **L1Y** (see “Special versions” in the “Selection and ordering data” under “Voltages”).

Order other types of construction with type of construction code **9** in the final position and the corresponding order code (see “Special versions” in the “Selection and ordering data” under “Types of construction”).

<sup>1)</sup> If motors frame sizes 180 M to 315 L in types of construction with feet IM B6, IM B7, IM V6 or IM V5 without protective cover are fixed to the wall, it is recommended that the motor feet are supported.

<sup>2)</sup> 1PP5 183-... to 1PP5 223-... motors (motor series 1PP5, frame size 180 M to 225 M) can be supplied with two additional eyebolts; specify supplement “**Z**” and order code **K32**.

<sup>3)</sup> 1PP6 253-... to 1PP6 318-... motors (motor series 1PP6 frame sizes 250 M to 315 L) are supplied with two screw-in eyebolts in accordance with IM B5, whereby one can be rotated in accordance with IM V1 or IM V3. It is important to note that stress must not be applied perpendicular to the ring plane.

<sup>4)</sup> Type of construction IM V3 is only possible using type of construction code **9** and order code **M1G**.

<sup>5)</sup> Not possible for type of construction IM V6 and IM V5 without protective cover.

# IEC Squirrel-Cage Motors

## Smoke-extraction motors

Forced-air cooled, for temperature/time classes F200, F300 – Aluminum series 1PP7/5, cast-iron series 1PP6

### Selection and ordering data (continued)

Rated output at 50 Hz		Frame size	Order No.	Price	Weight for type of construction IM B3 approx.
1500 rpm	3000 rpm				
$P_{\text{rated}}$ kW	$P_{\text{rated}}$ kW	FS	For Order No. supplements for voltage and type of construction, see table below		
<b>4/2-pole, 1500/3000 rpm at 50 Hz, cooling method IC 411, IP55 degree of protection, double pole-changing for driving smoke-extraction fans with one winding in Dahlander circuit, with test certificate in accordance with EN 12101-3</b>					
0.14	0.63	80 M	<b>1PP7 080-0TAQQ</b>		10.6
0.23	0.86	80 M	<b>1PP7 083-0TAQQ</b>		12.0
0.3	1.26	90 S	<b>1PP7 090-0TAQQ</b>		14.0
0.45	1.8	90 L	<b>1PP7 096-0TAQQ</b>		17.3
0.59	2.25	100 L	<b>1PP7 106-0TAQQ</b>		23.0
0.72	2.8	100 L	<b>1PP7 107-0TAQQ</b>		26.0
0.99	3.95	112 M	<b>1PP7 113-0TAQQ</b>		33.0
1.3	5.3	132 S	<b>1PP7 130-0TAQQ</b>		46.0
1.8	7.2	132 M	<b>1PP7 133-0TAQQ</b>		52.0
2.6	10.4	160 M	<b>1PP7 163-0TAQQ</b>		70.0
3.85	15.3	160 L	<b>1PP7 166-0TAQQ</b>		101.0
Rated output at 50 Hz		Frame size	Order No.	Price	Weight for type of construction IM B3 approx.
1000 rpm	1500 rpm				
$P_{\text{rated}}$ kW	$P_{\text{rated}}$ kW				
<b>6/4-pole, 1000/1500 rpm at 50 Hz, cooling method IC 411, IP55 degree of protection, double pole-changing for driving smoke-extraction fans with two windings, with test certificate in accordance with EN 12101-3</b>					
0.11	0.36	80 M	<b>1PP7 080-1TDQQ</b>		9.6
0.16	0.5	80 M	<b>1PP7 083-1TDQQ</b>		11.0
0.26	0.72	90 S	<b>1PP7 090-1TDQQ</b>		14.0
0.34	0.99	90 L	<b>1PP7 096-1TDQQ</b>		17.3
0.54	1.53	100 L	<b>1PP7 106-1TDQQ</b>		23.0
0.68	1.89	100 L	<b>1PP7 107-1TDQQ</b>		26.0
0.81	2.7	112 M	<b>1PP7 113-1TDQQ</b>		33.0
1.08	3.5	132 S	<b>1PP7 130-1TDQQ</b>		46.0
1.53	4.85	132 M	<b>1PP7 133-1TDQQ</b>		52.0
2.25	6.5	160 M	<b>1PP7 163-1TDQQ</b>		70.0
3.35	10.8	160 L	<b>1PP7 166-1TDQQ</b>		95.0
4.95	14.4	180 M	<b>1PP5 183-1TDQQ</b>		116.0
5.9	17.1	180 L	<b>1PP5 186-1TDQQ</b>		130.0
8.6	23.5	200 L	<b>1PP5 207-1TDQQ</b>		173.0
Rated output at 50 Hz		Frame size	Order No.	Price	Weight for type of construction IM B3 approx.
750 rpm	1500 rpm				
$P_{\text{rated}}$ kW	$P_{\text{rated}}$ kW				
<b>8/4-pole, 750/1500 rpm at 50 Hz, cooling method IC 411, IP55 degree of protection, double pole-changing for driving smoke-extraction fans with one winding in Dahlander circuit, with test certificate in accordance with EN12101-3</b>					
0.09	0.45	80 M	<b>1PP7 080-0TBQQ</b>		9.6
0.14	0.63	80 M	<b>1PP7 083-0TBQQ</b>		11.0
0.2	0.9	90 S	<b>1PP7 090-0TBQQ</b>		14.0
0.3	1.35	90 L	<b>1PP7 096-0TBQQ</b>		17.3
0.45	1.8	100 L	<b>1PP7 106-0TBQQ</b>		23.0
0.59	2.25	100 L	<b>1PP7 107-0TBQQ</b>		26.0
0.81	3.25	112 M	<b>1PP7 113-0TBQQ</b>		33.0
0.99	4.25	132 S	<b>1PP7 130-0TBQQ</b>		46.0
1.26	5.8	132 M	<b>1PP7 133-0TBQQ</b>		52.0
1.98	8.6	160 M	<b>1PP7 163-0TBQQ</b>		70.0
3	12.6	160 L	<b>1PP7 166-0TBQQ</b>		95.0
4.05	14.4	180 M	<b>1PP5 183-0TBQQ</b>		116.0
4.5	16.7	180 L	<b>1PP5 186-0TBQQ</b>		130.0
6.8	25	200 L	<b>1PP5 207-0TBQQ</b>		173.0

The rated outputs and weights may change slightly after they have been checked.

Further electrical data can be calculated and supplied on receipt of order.



# IEC Squirrel-Cage Motors

## Smoke-extraction motors

Forced-air cooled, for temperature/time classes F200, F300 – Aluminum series 1PP7/5, cast-iron series 1PP6

### Selection and ordering data (continued)

#### Order No. supplements

Motor type	Penultimate position: Voltage code			Final position: Type of construction code							
	50 Hz, direct online starting			Without flange	With flange			With standard flange		With special flange	
	230 V	400 V	500 V	IM B3/6/7/8, IM V6, IM V5 without protective cover	IM B5, IM V3 <sup>1)</sup>	IM V 1 without protective cover		IM B35	IM B14, IM V19/18 without protective cover	IM B34	IM B14, IM V19/18 without protective cover
	<b>1</b>	<b>6</b>	<b>5</b>	<b>0</b>	<b>1</b>	<b>1</b>	<b>8</b>	<b>6</b>	<b>2</b>	<b>7</b>	<b>3</b>
1PP7 08 .-. . . . □□	○	○	○	□	✓	✓	-	✓	✓	✓	✓
1PP7 09 .-. . . . □□	○	○	○	□	✓	✓	-	✓	✓	✓	✓
1PP7 10 .-. . . . □□	○	○	○	□	✓	✓	-	✓	✓	✓	✓
1PP7 11 .-. . . . □□	○	○	○	□	✓	✓	-	✓	✓	✓	✓
1PP7 13 .-. . . . □□	○	○	○	□	✓	✓	-	✓	✓	✓	✓
1PP7 16 .-. . . . □□	○	○	○	□	✓	✓	-	✓	✓	✓	✓
1PP5 18 .-. . . . □□	○	○	○	□	✓ <sup>2)</sup>	✓	-	✓	-	-	-
1PP5 20 .-. . . . □□	○	○	○	□	✓ <sup>2)</sup>	✓	-	✓	-	-	-

- Standard version
- Without additional charge
- ✓ With additional charge
- Not possible

Order other voltages with voltage code **9** in the penultimate position and with order code **L1Y** (see "Special versions" in the "Selection and ordering data" under "Voltages").

Order other types of construction with type of construction code **9** in the final position and the corresponding order code (see "Special versions" in the "Selection and ordering data" under "Types of construction").

1) 1PP5 183-... to 1PP5 223-... motors (motor series 1PP5, frame size 180 M to 225 M) can be supplied with two additional eyebolts; specify supplement "Z" and order code **K32**.

2) Type of construction IM V3 is only possible using type of construction code **9** and order code **M1G**.

# IEC Squirrel-Cage Motors

## Smoke-extraction motors

Self-ventilated, for temperature/time class F400  
Cast-iron series 1LA6, 1LG6

### Selection and ordering data

Rated output at 50 Hz	Frame size	Operating values at rated output						Locked-rotor torque with direct starting as multiple of rated torque	Locked-rotor current	Break-down torque	Torque class	Moment of inertia	Order No. For Order No. supplements for voltage and type of construction, see table below	Price	Weight
		Rated speed at 50 Hz	Rated torque at 50 Hz	Efficiency at 50 Hz 4/4-load	Power factor at 50 Hz 4/4-load	Rated current at 50 Hz 400 V	$\cos\phi_{\text{rated}}$								
$P_{\text{rated}}$ kW	FS	$n_{\text{rated}}$ rpm	$T_{\text{rated}}$ Nm	$\eta_{\text{rated}}$ %	$\cos\phi_{\text{rated}}$	$I_{\text{rated}}$ A	$T_{\text{LR}}/T_{\text{rated}}$	$I_{\text{LR}}/I_{\text{rated}}$	$T_{\text{B}}/T_{\text{rated}}$	CL	$J$ kg m <sup>2</sup>				
<b>2-pole, 3000 rpm at 50 Hz, cooling method IC 411, IP55 degree of protection, with test certificate according to EN 12101-3</b>															
3	100 L	2875	10	78.0	0.85	6.5	2.5	6.2	2.8	16	0.0038	<b>1LA6 106-2UAQQ</b>		32	
4	112 M	2900	13	78.0	0.85	8.7	2.5	6.8	2.9	16	0.0055	<b>1LA6 113-2UAQQ</b>		41	
5.5	132 S	2920	18	82.5	0.89	10.8	1.9	5.7	2.7	16	0.016	<b>1LA6 130-2UAQQ</b>		51	
7.5	132 S	2930	24	84.0	0.89	14.5	2.0	6.5	2.8	16	0.021	<b>1LA6 131-2UAQQ</b>		56	
11	160 M	2930	36	88.0	0.85	21	1.8	6.4	2.7	16	0.034	<b>1LA6 163-2UAQQ</b>		93	
15	160 M	2930	49	88.5	0.89	27.5	2.0	6.5	2.80	16	0.04	<b>1LA6 164-2UAQQ</b>		102	
18.5	160 L	2930	60	87.5	0.90	34	2.0	7.0	2.70	16	0.05	<b>1LA6 166-2UAQQ</b>		112	
22	180 M	2955	71	92.6	0.88	39	2.4	7.0	3.2	16	0.086	<b>1LG6 183-2UAQQ</b>		180	
30	200 L	2955	97	92.2	0.88	53	2.3	6.7	3.1	16	0.151	<b>1LG6 206-2UAQQ</b>		225	
37	200 L	2958	119	92.5	0.89	65	2.4	7.1	3.2	16	0.182	<b>1LG6 207-2UAQQ</b>		255	
45	225 M	2962	145	94.6	0.89	77	2.4	7.1	3.1	16	0.266	<b>1LG6 223-2UAQQ</b>		330	
55	250 M	2972	177	94.3	0.90	94	2.3	6.7	2.9	16	0.466	<b>1LG6 253-2UAQQ</b>		420	
75	280 S	2975	241	94.5	0.89	128	2.4	6.8	2.9	13	0.832	<b>1LG6 280-2UBQQ</b>		530	
90	280 M	2976	289	94.9	0.90	152	2.5	7.4	3.0	13	1.00	<b>1LG6 283-2UBQQ</b>		615	
110	315 S	2982	352	94.7	0.91	184	2.4	6.8	2.7	13	1.39	<b>1LG6 310-2UBQQ</b>		790	
132	315 M	2980	423	95.2	0.91	220	2.5	6.9	2.8	13	1.62	<b>1LG6 313-2UBQQ</b>		915	
160	315 L	2982	512	95.6	0.92	265	2.4	7.1	2.8	13	2.09	<b>1LG6 316-2UBQQ</b>		1055	
190	315 L	2982	608	95.9	0.93	325	2.6	7.2	2.9	13	2.46	<b>1LG6 317-2UBQQ</b>		1245	
<b>4-pole, 1500 rpm at 50 Hz, cooling method IC 411, IP55 degree of protection, with test certificate according to EN 12101-3</b>															
2.2	100 L	1410	15	74.0	0.75	5.6	2.2	5.2	2.7	16	0.0048	<b>1LA6 106-4UAQQ</b>		32	
3	100 L	1410	20	76.0	0.80	7.1	2.5	5.0	2.6	16	0.0058	<b>1LA6 107-4UAQQ</b>		34	
4	112 M	1440	27	79.0	0.76	9.8	2.7	5.7	3.0	16	0.011	<b>1LA6 113-4UAQQ</b>		43	
5.5	132 S	1455	36	78.0	0.75	13.5	2.5	6.3	3.0	16	0.018	<b>1LA6 130-4UAQQ</b>		53	
7.5	132 M	1455	49	84.0	0.75	17.2	2.7	6.7	3.1	16	0.024	<b>1LA6 133-4UAQQ</b>		60	
11	160 M	1460	72	82.5	0.80	24	2.2	6.2	2.7	16	0.04	<b>1LA6 163-4UAQQ</b>		97	
15	160 L	1460	98	81.5	0.80	33.5	2.4	6.4	2.8	16	0.052	<b>1LA6 166-4UAQQ</b>		110	
18.5	180 M	1470	120	90.7	0.84	35	2.4	6.1	2.8	16	0.122	<b>1LG6 183-4UAQQ</b>		155	
22	180 L	1472	143	91.7	0.85	40.5	2.4	6.4	2.9	16	0.144	<b>1LG6 186-4UAQQ</b>		180	
30	200 L	1470	195	92.2	0.86	55	2.4	6.4	3.1	16	0.234	<b>1LG6 207-4UAQQ</b>		225	
37	225 S	1480	239	92.6	0.86	67	2.6	6.5	2.8	16	0.398	<b>1LG6 220-4UAQQ</b>		290	
45	225 M	1480	290	93.3	0.86	81	2.7	6.6	2.9	16	0.486	<b>1LG6 223-4UAQQ</b>		330	
55	250 M	1485	354	94.2	0.87	97	2.5	7.4	2.9	16	0.856	<b>1LG6 253-4UAQQ</b>		460	
75	280 S	1484	483	94.2	0.87	132	2.4	6.7	2.8	16	1.39	<b>1LG6 280-4UAQQ</b>		574	
90	280 M	1486	578	94.7	0.86	160	2.6	7.3	3.0	16	1.71	<b>1LG6 283-4UAQQ</b>		675	
110	315 S	1488	706	95.0	0.87	192	2.7	7.0	2.8	16	2.31	<b>1LG6 310-4UAQQ</b>		810	
132	315 M	1488	847	95.3	0.88	225	2.6	7.1	2.8	16	2.88	<b>1LG6 313-4UAQQ</b>		965	
160	315 L	1490	1025	95.6	0.88	275	2.9	7.2	2.9	16	3.46	<b>1LG6 316-4UAQQ</b>		1105	
200	315 L	1488	1284	95.7	0.88	345	3.1	7.5	2.9	16	4.22	<b>1LG6 317-4UAQQ</b>		1305	

# IEC Squirrel-Cage Motors

## Smoke-extraction motors

Self-ventilated, for temperature/time class F400  
Cast-iron series 1LA6, 1LG6

### Selection and ordering data (continued)

#### Order No. supplements

Motor type	Penultimate position: Voltage code				Final position: Type of construction code									
	50 Hz				Without flange	With flange					With standard flange	With special flange		
	230 VΔ/400 VY	400 VΔ/690 VY	500 VY	500 VΔ	IM B3/6/7/8, IM V6, IM V5 without protective cover <sup>1)</sup>	IM B5, IM V3 <sup>2)</sup>	IM V1 without protective cover <sup>2)</sup>	IM V1 with protective cover <sup>2)3)</sup>	IM B35	IM B14, IM V19, IM V18 without protective cover	IM B34	IM B14, IM V19, IM V18 without protective cover		
	1	6	3	5	0	1	1	8	4	6	2	7	3	
1LA6 10 . . . . □□	○	○	○	○	□	✓	✓	–	✓	✓	✓	✓	✓	
1LA6 11 . . . . □□	○	○	○	○	□	✓	✓	–	✓	✓	✓	✓	✓	
1LA6 13 . . . . □□	○	○	○	○	□	✓	✓	–	✓	✓	✓	✓	✓	
1LA6 16 . . . . □□	○	○	○	○	□	✓	✓	–	✓	✓	✓	✓	✓	
1LA6 18 . . . . □□	○	○	○	○	□	✓ <sup>4)</sup>	✓	–	✓	✓	–	–	–	
1LG6 20 . . . . □□	○	○	○	○	□	✓ <sup>4)</sup>	✓	–	✓	✓	–	–	–	
1LG6 22 . . . . □□	○	○	○	○	□	✓ <sup>4)</sup>	✓	–	✓	✓	–	–	–	
1LG6 25 . . . . □□	○	○	○	○	□	✓ <sup>4)</sup>	✓	–	✓	✓	–	–	–	
1LG6 28 . . . . □□	○	○	○	○	□	✓ <sup>4)</sup>	✓	–	✓	✓	–	–	–	
1LG6 310 . . . . □□	○	○	○	○	□	✓ <sup>4)</sup>	✓	–	✓	✓	–	–	–	
1LG6 313 . . . . □□	○	○	○	○	□	✓ <sup>4)</sup>	✓	–	✓	✓	–	–	–	
1LG6 316 . . . . □□	–	○	–	○	□ <sup>5)</sup>	–	–	✓	✓	✓	–	–	–	
1LG6 317 . . . . □□	–	○	–	○	□ <sup>5)</sup>	–	–	✓	✓	✓	–	–	–	

- Standard version
- Without additional charge
- ✓ With additional charge
- Not possible

Order other voltages with voltage code **9** in the penultimate position and with order code **L1Y** (see “Special versions” in the “Selection and ordering data” under “Voltages”).

Order other types of construction with type of construction code **9** in the final position and the corresponding order code (see “Special versions” in the “Selection and ordering data” under “Types of construction”).

<sup>1)</sup> If motors 1LG6 183-... to 1LG6 317-... (motor series 1LG6 frame sizes 180 M to 315 L) in types of construction with feet IM B6, IM B7, IM V6 or IM V5 without protective cover are fixed to the wall, it is recommended that the motor feet are supported.

<sup>2)</sup> 1LG6 220-... to 1LG6 317-... motors (motor series 1LG6 frame sizes 225 S to 315 L) are supplied with two screw-in eyebolts in accordance with IM B5, whereby one can be rotated in accordance with IM V1 or IM V3. It is important to note that stress must not be applied perpendicular to the ring plane.

<sup>3)</sup> The “Second shaft extension” option, order code **K16** is not possible.

<sup>4)</sup> Type of construction IM V3 is only possible using type of construction code **9** and order code **M1G**.

<sup>5)</sup> Not possible for type of construction IM V6 and IM V5 without protective cover.

# IEC Squirrel-Cage Motors

## Smoke-extraction motors

Self-ventilated, for temperature/time class F400  
Cast-iron series 1LA6, 1LG6

### Selection and ordering data (continued)

Rated output at 50 Hz	Frame size	Operating values at rated output						Locked-rotor torque with direct starting as multiple of rated torque	Locked-rotor current	Break-down torque	Torque class	Moment of inertia	Order No. For Order No. supplements for voltage and type of construction, see table below	Price	Weight
		Rated speed at 50 Hz	Rated torque at 50 Hz	Efficiency at 50 Hz 4/4-load	Power factor at 50 Hz 4/4-load	Rated current at 50 Hz 400 V	$\cos\phi_{\text{rated}}$								
$P_{\text{rated}}$ kW	FS	$n_{\text{rated}}$ rpm	$T_{\text{rated}}$ Nm	$\eta_{\text{rated}}$ %	$\cos\phi_{\text{rated}}$	$I_{\text{rated}}$ A	$T_{\text{LR}}/T_{\text{rated}}$	$I_{\text{LR}}/I_{\text{rated}}$	$T_{\text{B}}/T_{\text{rated}}$	CL	$J$ kg m <sup>2</sup>				
<b>6-pole, 1000 rpm at 50 Hz, cooling method IC 411, IP55 degree of protection, with test certificate according to EN 12101-3</b>															
1.5	100 L	925	15	69.0	0.70	4.5	2.3	4.0	2.3	16	0.0063	<b>1LA6 106-6UAQQ</b>		32	
2.2	112 M	940	22	72.0	0.74	6.1	2.1	4.4	2.3	16	0.011	<b>1LA6 113-6UAQQ</b>		43	
3	132 S	950	30	74.0	0.75	7.8	1.6	4.1	1.7	16	0.015	<b>1LA6 130-6UAQQ</b>		54	
4	132 M	950	40	76.0	0.76	10	1.7	4.6	2.1	16	0.019	<b>1LA6 133-6UAQQ</b>		63	
5.5	132 M	950	55	75.0	0.76	14	2.0	5.0	2.3	16	0.025	<b>1LA6 134-6UAQQ</b>		74	
7.5	160 M	970	75	75.0	0.72	20	2.0	5.0	2.4	16	0.041	<b>1LA6 163-6UAQQ</b>		110	
11	160 L	970	109	80.0	0.72	27.5	2.0	5.0	2.5	16	0.049	<b>1LA6 166-6UAQQ</b>		132	
15	180 L	974	147	88.7	0.82	30	2.2	5.2	2.3	16	0.203	<b>1LG6 186-6UAQQ</b>		175	
18.5	200 L	975	181	89.4	0.82	36.5	2.2	5.3	2.3	16	0.285	<b>1LG6 206-6UAQQ</b>		210	
22	200 L	975	215	90.5	0.83	42.5	2.2	5.4	2.3	16	0.362	<b>1LG6 207-6UAQQ</b>		240	
30	225 M	980	292	92.2	0.84	56	2.7	6.3	2.8	16	0.629	<b>1LG6 223-6UAQQ</b>		325	
37	250 M	984	359	92.6	0.84	69	2.8	6.5	2.4	16	0.934	<b>1LG6 253-6UAQQ</b>		405	
45	280 S	986	436	92.3	0.86	82	2.8	6.3	2.5	16	1.37	<b>1LG6 280-6UAQQ</b>		520	
55	280 M	986	533	92.8	0.86	99	3.1	6.8	2.7	16	1.65	<b>1LG6 283-6UAQQ</b>		570	
75	315 S	990	723	93.7	0.84	138	2.7	7.0	2.9	16	2.50	<b>1LG6 310-6UAQQ</b>		760	
90	315 M	988	870	94.2	0.85	162	2.6	7.1	2.8	16	3.20	<b>1LG6 313-6UAQQ</b>		935	
110	315 L	988	1063	94.5	0.85	198	2.8	7.2	2.8	16	4.02	<b>1LG6 316-6UAQQ</b>		1010	
132	315 L	990	1273	94.9	0.85	235	3.0	7.5	3.0	16	4.71	<b>1LG6 317-6UAQQ</b>		1180	
160	315 L	988	1546	94.9	0.86	285	3.1	7.5	3.0	16	5.39	<b>1LG6 318-6UAQQ</b>		1245	

# IEC Squirrel-Cage Motors

## Smoke-extraction motors

Self-ventilated, for temperature/time class F400  
Cast-iron series 1LA6, 1LG6

### Selection and ordering data (continued)

#### Order No. supplements

Motor type	Penultimate position: Voltage code				Final position: Type of construction code								
	50 Hz				Without flange	With flange					With standard flange	With special flange	
	230 VΔ/400 VY	400 VΔ/690 VY	500 VY	500 VΔ	IM B3/6/7/8, IM V6, IM V5 without protective cover <sup>1)</sup>	IM B5, IM V3 <sup>2)</sup>	IM V1 without protective cover <sup>2)</sup>	IM V1 with protective cover <sup>2)3)</sup>	IM B35	IM B14, IM V19, IM V18 without protective cover	IM B34	IM B14, IM V19, IM V18 without protective cover	
	1	6	3	5	0	1	1	8	4	6	2	7	3
1LA6 10 . . . . □□	○	○	○	○	□	✓	✓	–	✓	✓	✓	✓	✓
1LA6 11 . . . . □□	○	○	○	○	□	✓	✓	–	✓	✓	✓	✓	✓
1LA6 13 . . . . □□	○	○	○	○	□	✓	✓	–	✓	✓	✓	✓	✓
1LA6 16 . . . . □□	○	○	○	○	□	✓	✓	–	✓	✓	✓	✓	✓
1LG6 18 . . . . □□	○	○	○	○	□	✓ <sup>4)</sup>	✓	–	✓	✓	–	–	–
1LG6 20 . . . . □□	○	○	○	○	□	✓ <sup>4)</sup>	✓	–	✓	✓	–	–	–
1LG6 22 . . . . □□	○	○	○	○	□	✓ <sup>4)</sup>	✓	–	✓	✓	–	–	–
1LG6 25 . . . . □□	○	○	○	○	□	✓ <sup>4)</sup>	✓	–	✓	✓	–	–	–
1LG6 28 . . . . □□	○	○	○	○	□	✓ <sup>4)</sup>	✓	–	✓	✓	–	–	–
1LG6 310 . . . . □□	○	○	○	○	□	✓ <sup>4)</sup>	✓	–	✓	✓	–	–	–
1LG6 313 . . . . □□	○	○	○	○	□	✓ <sup>4)</sup>	✓	–	✓	✓	–	–	–
1LG6 316 . . . . □□	–	○	–	○	□ <sup>5)</sup>	–	–	✓	✓	✓	–	–	–
1LG6 317 . . . . □□													
1LG6 318 . . . . □□													

- Standard version
- Without additional charge
- ✓ With additional charge
- Not possible

Order other voltages with voltage code **9** in the penultimate position and with order code **L1Y** (see “Special versions” in the “Selection and ordering data” under “Voltages”).

Order other types of construction with type of construction code **9** in the final position and the corresponding order code (see “Special versions” in the “Selection and ordering data” under “Types of construction”).

1) If motors 1LG6 183-... to 1LG6 318-... (motor series 1LG6 frame sizes 180 M to 315 L) in types of construction with feet IM B6, IM B7, IM V6 or IM V5 without protective cover are fixed to the wall, it is recommended that the motor feet are supported.

2) 1LG6 220-... to 1LG6 318-... motors (motor series 1LG6 frame sizes 225 S to 315 L) are supplied with two screw-in eyebolts in accordance with IM B5, whereby one can be rotated in accordance with IM V1 or IM V3. It is important to note that stress must not be applied perpendicular to the ring plane.

3) The “Second shaft extension” option, order code **K16** is not possible.

4) Type of construction IM V3 is only possible using type of construction code **9** and order code **M1G**.

5) Not possible for type of construction IM V6 and IM V5 without protective cover.

# IEC Squirrel-Cage Motors

## Smoke-extraction motors

Self-ventilated, for temperature/time class F400  
Cast-iron series 1LA6, 1LG6

### Selection and ordering data (continued)

Rated output at 50 Hz 1500 rpm	3000 rpm	Frame size	Order No. For Order No. supplements for voltage and type of construction, see table below	Price	Weight for type of construction IM B3 approx. <i>m</i> kg
$P_{\text{rated}}$ kW	$P_{\text{rated}}$ kW	FS			
<b>4/2-pole, 1500/3000 rpm at 50 Hz, cooling method IC 411, IP55 degree of protection, double pole-changing for driving smoke-extraction fans with one winding in Dahlander circuit, with test certificate in accordance with EN 12101-3</b>					
0.52	2	100 L	<b>1LA6 106-0UAQQ</b>		32
0.64	2.5	100 L	<b>1LA6 107-0UAQQ</b>		35
0.88	3.5	112 M	<b>1LA6 113-0UAQQ</b>		43
1.16	4.7	132 S	<b>1LA6 130-0UAQQ</b>		53
1.6	6.4	132 M	<b>1LA6 133-0UAQQ</b>		60
2.3	9.2	160 M	<b>1LA6 163-0UAQQ</b>		97
3.45	13.6	160 L	<b>1LA6 166-0UAQQ</b>		110
Rated output at 50 Hz 1000 rpm	1500 rpm				
$P_{\text{rated}}$ kW	$P_{\text{rated}}$ kW				
<b>6/4-pole, 1000/1500 rpm at 50 Hz, cooling method IC 411, IP55 degree of protection, double pole-changing for driving smoke-extraction fans with two windings, with test certificate in accordance with EN 12101-3</b>					
0.48	1.36	100 L	<b>1LA6 106-1UDQQ</b>		32
0.6	1.68	100 L	<b>1LA6 107-1UDQQ</b>		35
0.72	2.4	112 M	<b>1LA6 113-1UDQQ</b>		43
0.96	3.1	132 S	<b>1LA6 130-1UDQQ</b>		53
1.36	4.3	132 M	<b>1LA6 133-1UDQQ</b>		60
2	5.75	160 M	<b>1LA6 163-1UDQQ</b>		97
2.95	9.6	160 L	<b>1LA6 166-1UDQQ</b>		110
Rated output at 50 Hz 750 rpm	1500 rpm				
$P_{\text{rated}}$ kW	$P_{\text{rated}}$ kW				
<b>8/4-pole, 750/1500 rpm at 50 Hz, cooling method IC 411, IP55 degree of protection, double pole-changing for driving smoke-extraction fans with one winding in Dahlander circuit, with test certificate in accordance with EN 12101-3</b>					
0.3	1.6	100 L	<b>1LA6 106-0UBQQ</b>		32
0.52	2	100 L	<b>1LA6 107-0UBQQ</b>		35
0.72	2.85	112 M	<b>1LA6 113-0UBQQ</b>		43
0.88	3.75	132 S	<b>1LA6 130-0UBQQ</b>		53
1.12	5.1	132 M	<b>1LA6 133-0UBQQ</b>		60
1.76	7.6	160 M	<b>1LA6 163-0UBQQ</b>		97
2.6	11.2	160 L	<b>1LA6 166-0UBQQ</b>		110

The rated outputs and weights may change slightly after they have been checked.

Further electrical data can be calculated and supplied on receipt of order.

# IEC Squirrel-Cage Motors

## Smoke-extraction motors

Self-ventilated, for temperature/time class F400  
Cast-iron series 1LA6, 1LG6

### Selection and ordering data (continued)

#### Order No. supplements

Motor type	Penultimate position: Voltage code			Final position: Type of construction code								
	50 Hz, direct online starting			Without flange	With flange				With standard flange		With special flange	
	230 V	400 V	500 V	IM B3/6/7/8, IM V6, IM V5 without protective cover	IM B5, IM V3	IM V1 without protective cover	IM V1 with protective cover <sup>1)</sup>	IM B35	IM B14, IM V19, IM V18 without protective cover	IM B34	IM B14, IM V19, IM V18 without protective cover	
	1	6	5	0	1	1	8	4	6	2	7	3
1LA6 10 . . . . □□	○	○	○	□	✓	✓	–	✓	✓	✓	✓	✓
1LA6 11 . . . . □□	○	○	○	□	✓	✓	–	✓	✓	✓	✓	✓
1LA6 13 . . . . □□	○	○	○	□	✓	✓	–	✓	✓	✓	✓	✓
1LA6 16 . . . . □□	○	○	○	□	✓	✓	–	✓	✓	✓	✓	✓

- Standard version
- Without additional charge
- ✓ With additional charge
- Not possible

Order other voltages with voltage code **9** in the penultimate position and with order code **L1Y** (see “Special versions” in the “Selection and ordering data” under “Voltages”).

Order other types of construction with type of construction code **9** in the final position and the corresponding order code (see “Special versions” in the “Selection and ordering data” under “Types of construction”).

<sup>1)</sup> The “Second shaft extension” option, order code **K16** is not possible.

# IEC Squirrel-Cage Motors

## Smoke-extraction motors

Forced-air cooled, for temperature/time class F400  
Cast-iron series 1PP6

### Selection and ordering data

Rated output at 50 Hz	Frame size	Operating values at rated output						Locked-rotor torque with direct starting as multiple of rated torque	Locked-rotor current	Break-down torque	Torque class	Moment of inertia	Order No. For Order No. supplements for voltage and type of construction, see table below	Price	Weight
		Rated speed at 50 Hz	Rated torque at 50 Hz	Efficiency at 50 Hz 4/4-load	Power factor at 50 Hz 4/4-load	Rated current at 50 Hz 400 V	$\cos\phi_{\text{rated}}$								
$P_{\text{rated}}$ kW	FS	$n_{\text{rated}}$ rpm	$T_{\text{rated}}$ Nm	$\eta_{\text{rated}}$ %	$\cos\phi_{\text{rated}}$	$I_{\text{rated}}$ A	$T_{\text{LR}}/T_{\text{rated}}$	$I_{\text{LR}}/I_{\text{rated}}$	$T_{\text{B}}/T_{\text{rated}}$	CL	$J$ kg m <sup>2</sup>			$m$ kg	
<b>2-pole, 3000 rpm at 50 Hz, cooling method IC 411, IP55 degree of protection, with test certificate according to EN 12101-3</b>															
3	100 L	2875	10	78.0	0.85	6.5	2.5	6.2	2.8	16	0.0038	<b>1PP6 106-2UAQQ</b>		31	
4	112 M	2900	13	78.0	0.85	8.7	2.5	6.8	2.9	16	0.0055	<b>1PP6 113-2UAQQ</b>		40	
5.5	132 S	2920	18	82.5	0.89	10.8	1.9	5.7	2.7	16	0.016	<b>1PP6 130-2UAQQ</b>		49	
7.5	132 S	2930	24	84.0	0.89	14.5	2.0	6.5	2.8	16	0.021	<b>1PP6 131-2UAQQ</b>		54	
11	160 M	2930	36	88.0	0.85	21	1.8	6.4	2.7	16	0.034	<b>1PP6 163-2UAQQ</b>		91	
15	160 M	2930	49	88.5	0.89	27.5	2.0	6.5	2.80	16	0.04	<b>1PP6 164-2UAQQ</b>		99	
18.5	160 L	2930	60	87.5	0.90	34	2.0	7.0	2.70	16	0.052	<b>1PP6 166-2UAQQ</b>		109	
22	180 M	2955	71	93.1	0.88	39	2.4	7.0	3.2	16	0.086	<b>1PP6 183-2UAQQ</b>		175	
30	200 L	2955	97	92.8	0.88	53	2.3	6.7	3.1	16	0.151	<b>1PP6 206-2UAQQ</b>		215	
37	200 L	2958	119	93.0	0.89	65	2.4	7.1	3.2	16	0.182	<b>1PP6 207-2UAQQ</b>		245	
45	225 M	2962	145	95.0	0.89	77	2.4	7.1	3.1	16	0.266	<b>1PP6 223-2UAQQ</b>		320	
55	250 M	2972	177	94.9	0.90	94	2.3	6.7	2.9	16	0.466	<b>1PP6 253-2UAQQ</b>		405	
75	280 S	2975	241	94.9	0.89	128	2.4	6.8	2.9	13	0.832	<b>1PP6 280-2UBQQ</b>		510	
90	280 M	2976	289	95.2	0.90	152	2.5	7.4	3.0	13	1.00	<b>1PP6 283-2UBQQ</b>		595	
110	315 S	2982	352	95.3	0.91	184	2.4	6.8	2.7	13	1.39	<b>1PP6 310-2UBQQ</b>		770	
132	315 M	2980	423	95.7	0.91	220	2.5	6.9	2.8	13	1.62	<b>1PP6 313-2UBQQ</b>		895	
160	315 L	2982	512	96.0	0.92	265	2.4	7.1	2.8	13	2.09	<b>1PP6 316-2UBQQ</b>		1035	
190	315 L	2982	608	96.3	0.93	325	2.6	7.2	2.9	13	2.46	<b>1PP6 317-2UBQQ</b>		1225	
<b>4-pole, 1500 rpm at 50 Hz, cooling method IC 411, IP55 degree of protection, with test certificate according to EN 12101-3</b>															
2.2	100 L	1410	15	74.0	0.75	5.6	2.2	5.2	2.7	16	0.0048	<b>1PP6 106-4UAQQ</b>		31	
3	100 L	1410	20	76.0	0.80	7.1	2.5	5.0	2.6	16	0.0058	<b>1PP6 107-4UAQQ</b>		34	
4	112 M	1440	27	79.0	0.76	9.8	2.7	5.7	3.0	16	0.011	<b>1PP6 113-4UAQQ</b>		42	
5.5	132 S	1455	36	78.0	0.75	13.5	2.5	6.3	3.0	16	0.018	<b>1PP6 130-4UAQQ</b>		51	
7.5	132 M	1455	49	84.0	0.75	17.2	2.7	6.7	3.1	16	0.024	<b>1PP6 133-4UAQQ</b>		58	
11	160 M	1460	72	82.5	0.80	24	2.2	6.2	2.7	16	0.04	<b>1PP6 163-4UAQQ</b>		95	
15	160 L	1460	98	81.5	0.80	33.5	2.4	6.4	2.8	16	0.052	<b>1PP6 166-4UAQQ</b>		108	
18.5	180 M	1470	120	91.2	0.84	35	2.4	6.1	2.8	16	0.122	<b>1PP6 183-4UAQQ</b>		150	
22	180 L	1472	143	92.1	0.85	40.5	2.4	6.4	2.9	16	0.144	<b>1PP6 186-4UAQQ</b>		175	
30	200 L	1470	195	92.6	0.86	55	2.4	6.4	3.1	16	0.234	<b>1PP6 207-4UAQQ</b>		215	
37	225 S	1480	239	92.9	0.86	67	2.6	6.5	2.8	16	0.398	<b>1PP6 220-4UAQQ</b>		280	
45	225 M	1480	290	93.6	0.86	81	2.7	6.6	2.9	16	0.486	<b>1PP6 223-4UAQQ</b>		320	
55	250 M	1485	354	94.5	0.87	97	2.5	7.4	2.9	16	0.856	<b>1PP6 253-4UAQQ</b>		445	
75	280 S	1484	483	94.6	0.87	132	2.4	6.7	2.8	16	1.39	<b>1PP6 280-4UAQQ</b>		554	
90	280 M	1486	578	95.1	0.86	160	2.6	7.3	3.0	16	1.71	<b>1PP6 283-4UAQQ</b>		655	
110	315 S	1488	706	95.3	0.87	192	2.7	7.0	2.8	16	2.31	<b>1PP6 310-4UAQQ</b>		790	
132	315 M	1488	847	95.6	0.88	225	2.6	7.1	2.8	16	2.88	<b>1PP6 313-4UAQQ</b>		945	
160	315 L	1490	1025	95.8	0.88	275	2.9	7.2	2.9	16	3.46	<b>1PP6 316-4UAQQ</b>		1085	
200	315 L	1488	1284	95.9	0.88	345	3.1	7.5	2.9	16	4.22	<b>1PP6 317-4UAQQ</b>		1285	



# IEC Squirrel-Cage Motors

## Smoke-extraction motors

Forced-air cooled, for temperature/time class F400  
Cast-iron series 1PP6

### Selection and ordering data (continued)

#### Order No. supplements

Motor type	Penultimate position: Voltage code				Final position: Type of construction code							
	50 Hz				Without flange	With flange			With standard flange	With special flange		
	230 VΔ/ 400 VY	400 VΔ/ 690 VY	500 VY	500 VΔ	IM B3/6/7/8, IM V6, IM V5 without protective cover <sup>1)</sup>	IM B5, IM V3 <sup>2)</sup>	IM V1 without protective cover	IM B35	IM B14, IM V19, IM V18 without protective cover	IM B34	IM B14, IM V19, IM V18 without protective cover	
	1	6	3	5	0	1	1	8	6	2	7	3
1PP6 10 .-. . . . □□	○	○	○	○	□	✓	✓	-	✓	✓	✓	✓
1PP6 11 .-. . . . □□	○	○	○	○	□	✓	✓	-	✓	✓	✓	✓
1PP6 13 .-. . . . □□	○	○	○	○	□	✓	✓	-	✓	✓	✓	✓
1PP6 16 .-. . . . □□	○	○	○	○	□	✓	✓	-	✓	✓	✓	✓
1PP6 18 .-. . . . □□	○	○	○	○	□	✓ <sup>3)</sup>	✓	-	✓	-	-	-
1PP6 20 .-. . . . □□	○	○	○	○	□	✓ <sup>3)</sup>	✓	-	✓	-	-	-
1PP6 22 .-. . . . □□	○	○	○	○	□	✓ <sup>3)</sup>	✓	-	✓	-	-	-
1PP6 25 .-. . . . □□	○	○	○	○	□	✓ <sup>3)</sup>	✓	-	✓	-	-	-
1PP6 28 .-. . . . □□	○	○	○	○	□	✓ <sup>3)</sup>	✓	-	✓	-	-	-
1PP6 310 .-. . . . □□	○	○	○	○	□	✓ <sup>3)</sup>	✓	-	✓	-	-	-
1PP6 313 .-. . . . □□	○	○	○	○	□	✓ <sup>3)</sup>	✓	-	✓	-	-	-
1PP6 316 .-. . . . □□	-	○	-	○	□ <sup>4)</sup>	-	-	✓	✓	-	-	-
1PP6 317 .-. . . . □□	-	○	-	○	□ <sup>4)</sup>	-	-	✓	✓	-	-	-

- Standard version
- Without additional charge
- ✓ With additional charge
- Not possible

Order other voltages with voltage code **9** in the penultimate position and with order code **L1Y** (see "Special versions" in the "Selection and ordering data" under "Voltages").

Order other types of construction with type of construction code **9** in the final position and the corresponding order code (see "Special versions" in the "Selection and ordering data" under "Types of construction").

<sup>1)</sup> If motors 1PP6 183-... to 1PP6 318-... (motor series 1PP6 frame sizes 180 M to 315 L) in types of construction with feet IM B6, IM B7, IM V6 or IM V5 without protective cover are fixed to the wall, it is recommended that the motor feet are supported.

<sup>2)</sup> 1PP6 220-... to 1PP6 318-... motors (motor series 1PP6 frame sizes 225 S to 315 L) are supplied with two screw-in eyebolts in accordance with IM B5, whereby one can be rotated in accordance with IM V1 or IM V3. It is important to note that stress must not be applied perpendicular to the ring plane.

<sup>3)</sup> Type of construction IM V3 is only possible using type of construction code **9** and order code **M1G**.

<sup>4)</sup> Not possible for type of construction IM V6 and IM V5 without protective cover.

# IEC Squirrel-Cage Motors

## Smoke-extraction motors

Forced-air cooled, for temperature/time class F400  
Cast-iron series 1PP6

### Selection and ordering data (continued)

Rated output at 50 Hz	Frame size	Operating values at rated output						Locked-rotor torque with direct starting as multiple of rated torque	Locked-rotor current	Break-down torque	Torque class	Moment of inertia	Order No. For Order No. supplements for voltage and type of construction, see table below	Price	Weight
		Rated speed at 50 Hz	Rated torque at 50 Hz	Efficiency at 50 Hz 4/4-load	Power factor at 50 Hz 4/4-load	Rated current at 50 Hz 400 V	$\cos\phi_{\text{rated}}$								
$P_{\text{rated}}$ kW	FS	$n_{\text{rated}}$ rpm	$T_{\text{rated}}$ Nm	$\eta_{\text{rated}}$ %	$\cos\phi_{\text{rated}}$	$I_{\text{rated}}$ A	$T_{\text{LR}}/T_{\text{rated}}$	$I_{\text{LR}}/I_{\text{rated}}$	$T_{\text{B}}/T_{\text{rated}}$	CL	$J$ kg m <sup>2</sup>				
<b>6-pole, 1000 rpm at 50 Hz, cooling method IC 411, IP55 degree of protection, with test certificate according to EN 12101-3</b>															
1.5	100 L	925	15	69.0	0.70	4.5	2.3	4.0	2.3	16	0.0063	<b>1PP6 106-6UAQQ</b>		31	
2.2	112 M	940	22	72.0	0.74	6.0	2.1	4.4	2.3	16	0.011	<b>1PP6 113-6UAQQ</b>		42	
3	132 S	950	30	74.0	0.75	7.8	1.6	4.1	1.7	16	0.015	<b>1PP6 130-6UAQQ</b>		52	
4	132 M	950	40	76.0	0.76	10	1.7	4.6	2.1	16	0.019	<b>1PP6 133-6UAQQ</b>		62	
5.5	132 M	950	55	75.0	0.76	14	2.0	5.0	2.3	16	0.025	<b>1PP6 134-6UAQQ</b>		72	
7.5	160 M	970	75	75.0	0.72	20	2.0	5.0	2.4	16	0.041	<b>1PP6 163-6UAQQ</b>		107	
11	160 L	970	109	80.0	0.72	27.5	2.0	5.0	2.5	16	0.049	<b>1PP6 166-6UAQQ</b>		129	
15	180 L	975	147	88.9	0.82	30	2.2	5.2	2.3	16	0.203	<b>1PP6 186-6UAQQ</b>		170	
18.5	200 L	975	181	89.8	0.82	36.5	2.2	5.3	2.3	16	0.285	<b>1PP6 206-6UAQQ</b>		200	
22	200 L	975	215	90.8	0.83	42.5	2.2	5.4	2.3	16	0.362	<b>1PP6 207-6UAQQ</b>		230	
30	225 M	980	292	92.3	0.84	56	2.7	6.3	2.8	16	0.629	<b>1PP6 223-6UAQQ</b>		315	
37	250 M	984	359	93.0	0.84	69	2.8	6.5	2.4	16	0.934	<b>1PP6 253-6UAQQ</b>		390	
45	280 S	986	436	92.6	0.86	82	2.8	6.3	2.5	16	1.37	<b>1PP6 280-6UAQQ</b>		500	
55	280 M	986	533	93.1	0.86	99	3.1	6.8	2.7	16	1.65	<b>1PP6 283-6UAQQ</b>		550	
75	315 S	990	723	94.0	0.84	138	2.7	7.0	2.9	16	2.50	<b>1PP6 310-6UAQQ</b>		740	
90	315 M	988	870	94.5	0.85	162	2.6	7.1	2.8	16	2.50	<b>1PP6 313-6UAQQ</b>		915	
110	315 L	988	1063	94.7	0.85	198	2.8	7.2	2.8	16	2.50	<b>1PP6 316-6UAQQ</b>		990	
132	315 L	990	1273	95.1	0.85	235	3.0	7.5	3.0	16	2.50	<b>1PP6 317-6UAQQ</b>		1160	
160	315 L	988	1546	95.1	0.86	285	3.1	7.5	3.0	16	2.50	<b>1PP6 318-6UAQQ</b>		1225	

# IEC Squirrel-Cage Motors

## Smoke-extraction motors

Forced-air cooled, for temperature/time class F400  
Cast-iron series 1PP6

### Selection and ordering data (continued)

#### Order No. supplements

Motor type	Penultimate position: Voltage code				Final position: Type of construction code							
	50 Hz				Without flange	With flange			With standard flange		With special flange	
	230 VΔ/ 400 VY	400 VΔ/ 690 VY	500 VY	500 VΔ	IM B3/6/7/8, IM V6, IM V5 without protective cover <sup>1)</sup>	IM B5, IM V3 <sup>2)</sup>	IM V1 without protective cover	IM B35	IM B14, IM V19, IM V18 without protective cover	IM B34	IM B14, IM V19, IM V18 without protective cover	
	<b>1</b>	<b>6</b>	<b>3</b>	<b>5</b>	<b>0</b>	<b>1</b>	<b>1</b>	<b>8</b>	<b>6</b>	<b>2</b>	<b>7</b>	<b>3</b>
1PP6 10 .-. . . . □□	○	○	○	○	□	✓	✓	-	✓	✓	✓	✓
1PP6 11 .-. . . . □□	○	○	○	○	□	✓	✓	-	✓	✓	✓	✓
1PP6 13 .-. . . . □□	○	○	○	○	□	✓	✓	-	✓	✓	✓	✓
1PP6 16 .-. . . . □□	○	○	○	○	□	✓	✓	-	✓	✓	✓	✓
1PP6 18 .-. . . . □□	○	○	○	○	□	✓ <sup>3)</sup>	✓	-	✓	-	-	-
1PP6 20 .-. . . . □□	○	○	○	○	□	✓ <sup>3)</sup>	✓	-	✓	-	-	-
1PP6 22 .-. . . . □□	○	○	○	○	□	✓ <sup>3)</sup>	✓	-	✓	-	-	-
1PP6 25 .-. . . . □□	○	○	○	○	□	✓ <sup>3)</sup>	✓	-	✓	-	-	-
1PP6 28 .-. . . . □□	○	○	○	○	□	✓ <sup>3)</sup>	✓	-	✓	-	-	-
1PP6 310 .-. . . . □□	○	○	○	○	□	✓ <sup>3)</sup>	✓	-	✓	-	-	-
1PP6 313 .-. . . . □□	○	○	○	○	□	✓ <sup>3)</sup>	✓	-	✓	-	-	-
1PP6 316 .-. . . . □□	-	○	-	○	□ <sup>4)</sup>	-	-	✓	✓	-	-	-
1PP6 317 .-. . . . □□												
1PP6 318 .-. . . . □□												

- Standard version
- Without additional charge
- ✓ With additional charge
- Not possible

Order other voltages with voltage code **9** in the penultimate position and with order code **L1Y** (see "Special versions" in the "Selection and ordering data" under "Voltages").

Order other types of construction with type of construction code **9** in the final position and the corresponding order code (see "Special versions" in the "Selection and ordering data" under "Types of construction").

<sup>1)</sup> If motors 1PP6 183-... to 1PP6 318-... (motor series 1PP6 frame sizes 180 M to 315 L) in types of construction with feet IM B6, IM B7, IM V6 or IM V5 without protective cover are fixed to the wall, it is recommended that the motor feet are supported.

<sup>2)</sup> 1PP6 220-... to 1PP6 318-... motors (motor series 1PP6 frame sizes 225 S to 315 L) are supplied with two screw-in eyebolts in accordance with IM B5, whereby one can be rotated in accordance with IM V1 or IM V3. It is important to note that stress must not be applied perpendicular to the ring plane.

<sup>3)</sup> Type of construction IM V3 is only possible using type of construction code **9** and order code **M1G**.

<sup>4)</sup> Not possible for type of construction IM V6 and IM V5 without protective cover.

# IEC Squirrel-Cage Motors

## Smoke-extraction motors

Forced-air cooled, for temperature/time class F400  
Cast-iron series 1PP6

### Selection and ordering data (continued)

Rated output at 50 Hz 1500 rpm	3000 rpm	Frame size	Order No.	Price	Weight for type of construction IM B3 approx.
$P_{\text{rated}}$ kW	$P_{\text{rated}}$ kW	FS	For Order No. supplements for voltage and type of construction, see table below		$m$ kg
<b>4/2-pole, 1500/3000 rpm at 50 Hz, cooling method IC 411, IP55 degree of protection, double pole-changing for driving smoke-extraction fans with one winding in Dahlander circuit, with test certificate in accordance with EN 12101-3</b>					
0.52	2	100 L	<b>1PP6 106-0UAQQ</b>		31
0.64	2.5	100 L	<b>1PP6 107-0UAQQ</b>		34
0.88	3.5	112 M	<b>1PP6 113-0UAQQ</b>		42
1.16	4.7	132 S	<b>1PP6 130-0UAQQ</b>		51
1.6	6.4	132 M	<b>1PP6 133-0UAQQ</b>		58
2.3	9.2	160 M	<b>1PP6 163-0UAQQ</b>		95
3.45	13.6	160 M	<b>1PP6 166-0UAQQ</b>		108
<b>6/4-pole, 1000/1500 rpm at 50 Hz, cooling method IC 411, IP55 degree of protection, double pole-changing for driving smoke-extraction fans with two windings, with test certificate in accordance with EN 12101-3</b>					
0.48	1.36	100 L	<b>1PP6 106-1UDQQ</b>		31
0.6	1.68	100 L	<b>1PP6 107-1UDQQ</b>		34
0.72	2.4	112 M	<b>1PP6 113-1UDQQ</b>		42
0.96	3.1	132 S	<b>1PP6 130-1UDQQ</b>		51
1.36	4.3	132 M	<b>1PP6 133-1UDQQ</b>		58
2	5.75	160 M	<b>1PP6 163-1UDQQ</b>		95
2.95	9.6	160 L	<b>1PP6 166-1UDQQ</b>		108
<b>8/4-pole, 750/1500 rpm at 50 Hz, cooling method IC 411, IP55 degree of protection, double pole-changing for driving smoke-extraction fans with one winding in Dahlander circuit, with test certificate in accordance with EN 12101-3</b>					
0.3	1.6	100 L	<b>1PP6 106-0UBQQ</b>		31
0.52	2	100 L	<b>1PP6 107-0UBQQ</b>		34
0.72	2.85	112 M	<b>1PP6 113-0UBQQ</b>		42
0.88	3.75	132 S	<b>1PP6 130-0UBQQ</b>		51
1.12	5.1	132 M	<b>1PP6 133-0UBQQ</b>		58
1.76	7.6	160 M	<b>1PP6 163-0UBQQ</b>		95
2.6	11.2	160 L	<b>1PP6 166-0UBQQ</b>		108

The rated outputs and weights may change slightly after they have been checked.

Further electrical data can be calculated and supplied on receipt of order.

# IEC Squirrel-Cage Motors

## Smoke-extraction motors

Forced-air cooled, for temperature/time class F400  
Cast-iron series 1PP6

### Selection and ordering data (continued)

#### Order No. supplements

Motor type	Penultimate position: Voltage code			Final position: Type of construction code							
	50 Hz, direct online starting			Without flange	With flange			With standard flange		With special flange	
	230 V	400 V	500 V	IM B3/6/7/8, IM V6, IM V5 without protective cover	IM B5, IM V3	IM V1 without protective cover		IM B35	IM B14, IM V19, IM V18 without protective cover	IM B34	IM B14, IM V19, IM V18 without protective cover
	1	6	5	0	1	1	8	6	2	7	3
1PP6 10 . . . . □□	○	○	○	□	✓	✓	–	✓	✓	✓	✓
1PP6 11 . . . . □□	○	○	○	□	✓	✓	–	✓	✓	✓	✓
1PP6 13 . . . . □□	○	○	○	□	✓	✓	–	✓	✓	✓	✓
1PP6 16 . . . . □□	○	○	○	□	✓	✓	–	✓	✓	✓	✓

- Standard version
- Without additional charge
- ✓ With additional charge
- Not possible

Order other voltages with voltage code **9** in the penultimate position and with order code **L1Y** (see “Special versions” in the “Selection and ordering data” under “Voltages”).

Order other types of construction with type of construction code **9** in the final position and the corresponding order code (see “Special versions” in the “Selection and ordering data” under “Types of construction”).

# IEC Squirrel-Cage Motors

## Smoke-extraction motors

### Special versions

#### Selection and ordering data

##### Voltages

Additional order codes for other voltages or voltage codes  
(without “-Z” supplement)

For some non-standard voltages at 50 or 60 Hz, order codes are specified. They are ordered by specifying the code digit 9 for voltage in the 11th position of the Order No. and the appropriate order code.

Plain text must be specified in the order:

Voltage, frequency, circuit, required rated output in kW.

Special versions	Voltage code 11th position of Order No.	Additional identification code with order code and plain text if required	Motor type frame size														
			56	63	71	80	90	100	112	132	160	180	200	225	250	280	315
<b>Self-ventilated motors</b>																	
Non-standard winding for voltages between 200 V and 690 V, (voltages outside this range are available on request) <sup>1)</sup>	9	L1Y •															
Non-standard winding for voltages between 200 V and 690 V, (voltages outside this range are available on request) <sup>1)</sup>	9	L1Y •															
<b>Forced-air cooled motors</b>																	
Non-standard winding for voltages between 200 V and 690 V, (voltages outside this range are available on request) <sup>1)</sup>	9	L1Y •															
Non-standard winding for voltages between 200 V and 690 V, (voltages outside this range are available on request) <sup>1)</sup>	9	L1Y •															

- ✓ With additional charge
- This order code only determines the price of the version – Additional plain text is required.

<sup>1)</sup> When ordering, specify in plain text: Voltage, frequency, circuit, required rated output in kW

# IEC Squirrel-Cage Motors

## Smoke-extraction motors

### Special versions

#### Types of construction

Additional order codes for other types of construction or type of construction codes (without "-Z" supplement)

Order codes have been defined for some special types of construction. They are ordered by specifying the code digit 9 for the type of construction in the 12th position of the Order No. and the appropriate order code.

Special versions	Type of construction code 12th position of Order No.	Additional identification code with order code and plain text if required	Motor type frame size																	
			56	63	71	80	90	100	112	132	160	180	200	225	250	280	315 S/M	315 L		
<b>Self-ventilated motors</b>																				
									1LA7 (aluminum) temperature/time classes F200 and F300			1LA5 (aluminum) temperature/time classes F200 and F300								
<b>With flange</b>																				
IM V3	9	M1G	-	-	-	-	-	-	-	-	-	-	✓	✓	✓					
<b>With special flange</b>																				
IM B34	9	M2C	✓	✓	✓	✓	✓	✓	✓	✓	✓	✓	-	-	-					
									1LA6 (cast-iron) temperature/time class F400			1LG6 (cast-iron) temperature/time classes F200, F300 and F400								
<b>With flange</b>																				
IM V3 <sup>1)</sup>	9	M1G	-	-	-	-	-	-	-	-	-	-	✓	✓	✓	✓	✓			
<b>With special flange</b>																				
IM B34	9	M2C	✓	✓	✓	✓	✓	✓	✓	✓	✓	✓	-	-	-	-	-			
<b>Forced-air cooled motors</b>																				
									1PP7 (aluminum) temperature/time classes F200 and F300			1PP5 (aluminum) temperature/time classes F200 and F300								
<b>With flange</b>																				
IM V3	9	M1G	-	-	-	-	-	-	-	-	-	-	✓	✓	✓					
<b>With special flange</b>																				
IM B34	9	M2C	✓	✓	✓	✓	✓	✓	✓	✓	✓	✓	-	-	-					
									1PP6 (cast-iron) temperature/time classes F200, F300 and F400											
<b>With flange</b>																				
IM V3 <sup>1)</sup>	9	M1G	-	-	-	-	-	-	-	-	-	-	✓	✓	✓	✓	✓			
<b>With special flange</b>																				
IM B34	9	M2C	✓	✓	✓	✓	✓	✓	✓	✓	✓	✓	-	-	-	-	-			

- ✓ With additional charge
- Not possible

<sup>1)</sup> 1LG6/1PP6 motors of frame sizes 225 S to 315 M are supplied with two screw-in eyebolts in accordance with IM B5, whereby one can be rotated in accordance with IM V1; four eyebolts (instead of two) with frame size 315 L. It is important to note that stress must not be applied perpendicular to the ring plane.

# IEC Squirrel-Cage Motors

## Smoke-extraction motors

### Special versions

#### Options

Options or order codes (supplement **-Z** is required)

Special versions	Additional identification code <b>-Z</b> with order code and plain text if required	Motor type frame size														
		56	63	71	80	90	100	112	132	160	180	200	225	250	280	315
<b>Self-ventilated motors</b>																



# IEC Squirrel-Cage Motors

## Smoke-extraction motors

### Special versions

Special versions	Additional identification code <b>-Z</b> with order code and plain text if required	Motor type frame size														
		56	63	71	80	90	100	112	132	160	180	200	225	250	280	315
<b>Self-ventilated motors</b>																
					<b>1LA7 (aluminum) temperature/time classes F200 and F300</b>						<b>1LA5 (aluminum) temperature/time classes F200 and F300</b>					
<b>Bearings and lubrication</b>																
Measuring nipple for SPM shock pulse measurement for bearing inspection	<b>G50</b>				–	–	✓	✓	✓	✓	✓	✓	✓	✓	✓	✓
Regreasing device	<b>K40</b>				–	–	✓	✓	✓	✓	✓	✓	✓	✓	✓	✓
<b>Balance and vibration quantity</b>																
Vibration quantity A					□	□	□	□	□	□	□	□	□	□	□	□
Vibration quantity B	<b>K02</b>				✓	✓	✓	✓	✓	✓	✓	✓	✓	✓	✓	✓
Full key balancing	<b>L68</b>				✓	✓	✓	✓	✓	✓	✓	✓	✓	✓	✓	✓
Balancing without key	<b>M37</b>				✓	✓	✓	✓	✓	✓	✓	✓	✓	✓	✓	✓
<b>Heating and ventilation</b>																
Anti-condensation heaters for 230 V	<b>K45</b>				✓	✓	✓	✓	✓	✓	✓	✓	✓	✓	✓	✓
Anti-condensation heaters for 115 V	<b>K46</b>				✓	✓	✓	✓	✓	✓	✓	✓	✓	✓	✓	✓
<b>Rating plate and extra rating plates</b>																
Second lubricating plate, supplied loose	<b>B06</b>				–	–	✓	✓	✓	✓	✓	✓	✓	✓	✓	✓
Second rating plate, loose (standard version)					□	□	□	□	□	□	□	□	□	□	□	□
Extra rating plate with identification code	<b>Y82 •</b> and identification code				✓	✓	✓	✓	✓	✓	✓	✓	✓	✓	✓	✓
Additional information on rating plate and on package label (maximum of 20 characters)	<b>Y84 •</b> and identification code				✓	✓	✓	✓	✓	✓	✓	✓	✓	✓	✓	✓
<b>Packaging, safety notes and test certificates</b>																
Acceptance test certificate 3.1 according to EN 10204	<b>B02</b>				✓	✓	✓	✓	✓	✓	✓	✓	✓	✓	✓	✓
Operating instructions German/English enclosed in print	<b>B23</b>				✓	✓	✓	✓	✓	✓	✓	✓	✓	✓	✓	✓
Type test with heat run for horizontal motors, with acceptance	<b>F83</b>				✓	✓	✓	✓	✓	✓	✓	✓	✓	✓	✓	✓
Wire-lattice pallet	<b>L99</b>				○	○	○	○	○	○	○	○	○	–	–	–

- Standard version
- Without additional charge
- ✓ With additional charge
- Not possible
- This order code only determines the price of the version – Additional plain text is required.
- . R. Possible on request

<sup>1)</sup> Evaluation with appropriate tripping unit (see Catalog LV 1) is recommended. Double the number of temperature sensors are required for pole-changing motors with separate windings. (Order code A11, price of A12 or order code A12, prices on request).

<sup>2)</sup> No additional charge with types of construction without feet: IM B5, IM V1, IM V3.

<sup>3)</sup> Supplied with the condensation drainage holes sealed at the drive end DE and non-drive end NDE for IP55, IP56 and IP65 degrees of protection. If condensation drainage holes are required in motors of the IM B6, IM B7 or IM B8 type of construction (feet located on side or top), it is necessary to relocate the bearing plates at the drive end (DE) and non-drive end (NDE) so that the condensation drainage holes situated between the feet on delivery are underneath.

# IEC Squirrel-Cage Motors

## Smoke-extraction motors

### Special versions

Special versions	Additional identification code <b>-Z</b> with order code and plain text if required	Motor type frame size														
		56	63	71	80	90	100	112	132	160	180	200	225	250	280	315
<b>Self-ventilated motors</b>																
<b>Motor protection</b>																
Motor protection with PTC thermistors with 3 embedded temperature sensors for tripping <sup>1)</sup>	<b>A11</b>						✓	✓	✓	✓	✓	✓	✓	✓	✓	✓
Motor protection with PTC thermistors with 6 embedded temperature sensors for tripping and alarm <sup>1)</sup>	<b>A12</b>						✓	✓	✓	✓	✓	✓	✓	✓	✓	✓
Motor temperature detection with embedded temperature sensor KTY 84-130 <sup>1)</sup>	<b>A23</b>						✓	✓	✓	✓	✓	✓	✓	✓	✓	✓
Installation of 3 PT 100 resistance thermometers <sup>1)</sup>	<b>A60</b>						-	-	-	-	✓	✓	✓	✓	✓	✓
Installation of 6 PT 100 resistance thermometers in stator winding <sup>1)</sup>	<b>A61</b>						-	-	-	-	-	-	✓	✓	✓	✓
Installation of 2 PT 100 screw-in resistance thermometers (basic circuit) for rolling-contact bearings <sup>1)</sup>	<b>A72</b>						-	-	-	-	✓	✓	✓	✓	✓	✓
Installation of 2 PT 100 screw-in resistance thermometers (3-wire circuit) for rolling-contact bearings <sup>1)</sup>	<b>A78</b>						-	-	-	-	✓	✓	✓	✓	✓	✓
<b>Motor connection and connection box</b>																
External earthing	<b>L13</b>						✓	✓	✓	✓	□	□	□	□	□	□
Protruding cable ends – right side <sup>2)</sup>	<b>L51</b>						✓	○	○	○	✓	✓	✓	✓	✓	✓
Protruding cable ends – left side <sup>2)</sup>	<b>L52</b>						✓	○	○	○	✓	✓	✓	✓	✓	✓
<b>Colors and paint finish</b>																
Special finish in RAL 7030 stone gray							□	□	□	□	□	□	□	□	□	□
Special finish in other standard RAL colors: RAL 1002, 1013, 1015, 1019, 2003, 2004, 3000, 3007, 5007, 5009, 5010, 5012, 5015, 5017, 5018, 5019, 6011, 6019, 6021, 7000, 7001, 7004, 7011, 7016, 7022, 7031, 7032, 7033, 7035, 9001, 9002, 9005 Page 0/18	<b>Y54 •</b> and special finish RAL ....						✓	✓	✓	✓	✓	✓	✓	✓	✓	✓
Offshore special finish	<b>M91</b>						O. R.	O. R.	O. R.	O. R.	✓	✓	✓	✓	✓	✓
Sea air resistant special finish	<b>M94</b>						O. R.	O. R.	O. R.	O. R.	O. R.	O. R.	O. R.	O. R.	O. R.	O. R.
Unpainted (only cast iron parts primed)	<b>K23</b>						○	○	○	○	○	○	○	○	○	○
Unpainted, only primed	<b>K24</b>						✓	✓	✓	✓	✓	✓	✓	✓	✓	✓
<b>Mechanical design and degrees of protection</b>																
IP65 degree of protection	<b>K50</b>						✓	✓	✓	✓	✓	✓	✓	✓	✓	✓
Condensation drainage holes <sup>3)</sup>	<b>L12</b>						✓	✓	✓	✓	□	□	□	□	□	□
Non-rusting screws (externally)	<b>M27</b>						✓	✓	✓	✓	✓	✓	✓	✓	✓	✓

# IEC Squirrel-Cage Motors

## Smoke-extraction motors

**Special versions**

Special versions	Additional identification code -Z with order code and plain text if required	Motor type frame size																
		56	63	71	80	90	100	112	132	160	180	200	225	250	280	315		
<b>Self-ventilated motors</b>																		
											<b>1LA6 (cast-iron) temperature/time class F400</b>				<b>1LG6 (cast-iron) temperature/time classes F200, F300 and F400</b>			
<b>Bearings and lubrication</b>																		
Measuring nipple for SPM shock pulse measurement for bearing inspection	<b>G50</b>										✓	✓	✓	✓	✓	✓	✓	
Regreasing device	<b>K40</b>										✓	✓	✓	✓	✓	□	□	
<b>Balance and vibration quantity</b>																		
Vibration quantity A											□	□	□	□	□	□	□	
Vibration quantity B	<b>K02</b>										✓	✓	✓	✓	✓	✓	✓	
Full key balancing	<b>L68</b>										✓	✓	✓	✓	✓	✓	✓	
Balancing without key	<b>M37</b>										✓	✓	✓	✓	✓	✓	✓	
<b>Heating and ventilation</b>																		
Anti-condensation heaters for 230 V	<b>K45</b>										✓	✓	✓	✓	✓	✓	✓	
Anti-condensation heaters for 115 V	<b>K46</b>										✓	✓	✓	✓	✓	✓	✓	
<b>Rating plate and extra rating plates</b>																		
Second lubricating plate, supplied loose	<b>B06</b>										✓	✓	✓	✓	✓	✓	✓	
Second rating plate, loose (standard version)											□	□	□	□	□	□	□	
Extra rating plate with identification code	<b>Y82 •</b> and identification code										✓	✓	✓	✓	✓	✓	✓	
Additional information on rating plate and on package label (maximum of 20 characters)	<b>Y84 •</b> and identification code										✓	✓	✓	✓	✓	✓	✓	
<b>Packaging, safety notes and test certificates</b>																		
Acceptance test certificate 3.1 according to EN 10204	<b>B02</b>										✓	✓	✓	✓	✓	✓	✓	
Operating instructions German/English enclosed in print	<b>B23</b>										✓	✓	✓	✓	✓	✓	✓	
Type test with heat run for horizontal motors, with acceptance	<b>F83</b>										✓	✓	✓	✓	✓	✓	✓	
Wire-lattice pallet	<b>L99</b>										○	○	○	○	-	-	-	

- Standard version
- Without additional charge
- ✓ With additional charge
- Not possible
- This order code only determines the price of the version – Additional plain text is required.
- . R. Possible on request

<sup>1)</sup> Evaluation with appropriate tripping unit (see Catalog LV 1) is recommended. For pole-changing motors with separate windings, the number of temperature sensors must be doubled. (order code A11, price of A12 or order code A12, price available on request.)

<sup>2)</sup> No additional charge with types of construction without feet: IM B5, IM V1, IM V3.

<sup>3)</sup> Supplied with the condensation drainage holes sealed at the drive end DE and non-drive end NDE for IP55, IP56 and IP65 degrees of protection. If condensation drainage holes are required in motors of the IM B6, IM B7 or IM B8 type of construction (feet located on side or top), it is necessary to relocate the bearing plates at the drive end (DE) and non-drive end (NDE) so that the condensation drainage holes situated between the feet on delivery are underneath.

# IEC Squirrel-Cage Motors

## Smoke-extraction motors

### Special versions

Special versions	Additional identification code <b>-Z</b> with order code and plain text if required	Motor type frame size														
		56	63	71	80	90	100	112	132	160	180	200	225	250	280	315
<b>Forced-air cooled motors</b>																
<b>Motor protection</b>																
Motor protection with PTC thermistors with 3 embedded temperature sensors for tripping <sup>1)</sup>	<b>A11</b>				✓	✓	✓	✓	✓	✓	✓	✓	✓	✓	✓	✓
Motor protection with PTC thermistors with 6 embedded temperature sensors for tripping and alarm <sup>1)</sup>	<b>A12</b>				✓	✓	✓	✓	✓	✓	✓	✓	✓	✓	✓	✓
Motor temperature detection with embedded temperature sensor KTY 84-130 <sup>1)</sup>	<b>A23</b>				✓	✓	✓	✓	✓	✓	✓	✓	✓	✓	✓	✓
Installation of 3 PT 100 resistance thermometers <sup>1)</sup>	<b>A60</b>				-	-	-	-	-	-	-	-	-	✓		
<b>Motor connection and connection box</b>																
External earthing	<b>L13</b>				✓	✓	✓	✓	✓	✓	✓	✓	✓	✓	✓	✓
Protruding cable ends – right side <sup>2)</sup>	<b>L51</b>				✓	✓	✓	○	○	○	○	○	○	○	○	○
Protruding cable ends – left side <sup>2)</sup>	<b>L52</b>				✓	✓	✓	○	○	○	○	○	○	○	○	○
<b>Colors and paint finish</b>																
Special finish in RAL 7030 stone gray					□	□	□	□	□	□	□	□	□	□	□	□
Special finish in other standard RAL colors: RAL 1002, 1013, 1015, 1019, 2003, 2004, 3000, 3007, 5007, 5009, 5010, 5012, 5015, 5017, 5018, 5019, 6011, 6019, 6021, 7000, 7001, 7004, 7011, 7016, 7022, 7031, 7032, 7033, 7035, 9001, 9002, 9005 Page 0/18	<b>Y54 •</b> and special finish RAL ....				✓	✓	✓	✓	✓	✓	✓	✓	✓	✓	✓	✓
Sea air resistant special finish	<b>M94</b>				O. R.	O. R.	O. R.	O. R.	O. R.	O. R.	O. R.	O. R.	O. R.	O. R.	O. R.	O. R.
Unpainted (only cast iron parts primed)	<b>K23</b>				○	○	○	○	○	○	○	○	○	○	○	○
Unpainted, only primed	<b>K24</b>				✓	✓	✓	✓	✓	✓	✓	✓	✓	✓	✓	✓
<b>Mechanical design and degrees of protection</b>																
With two additional eyebolts for IM V1/IM V3	<b>K32</b>				-	-	-	-	-	-	-	✓	✓	✓		
IP65 degree of protection	<b>K50</b>				✓	✓	✓	✓	✓	✓	✓	✓	✓	✓	✓	✓
Condensation drainage holes <sup>3)</sup>	<b>L12</b>				✓	✓	✓	✓	✓	✓	✓	✓	✓	✓	✓	✓
Non-rusting screws (externally)	<b>M27</b>				✓	✓	✓	✓	✓	✓	✓	✓	✓	✓	✓	✓

# IEC Squirrel-Cage Motors

## Smoke-extraction motors

### Special versions

Special versions	Additional identification code <b>-Z</b> with order code and plain text if required	Motor type frame size															
		56	63	71	80	90	100	112	132	160	180	200	225	250	280	315	
<b>Forced-air cooled motors</b>																	
<b>Bearings and lubrication</b>																	
Measuring nipple for SPM shock pulse measurement for bearing inspection	<b>G50</b>				–	–	✓	✓	✓	✓	✓	✓	✓	✓	✓	✓	✓
Regreasing device	<b>K40</b>				–	–	✓	✓	✓	✓	✓	✓	✓	✓	✓	✓	✓
<b>Balance and vibration quantity</b>																	
Vibration quantity A					□	□	□	□	□	□	□	□	□	□	□	□	□
Vibration quantity B	<b>K02</b>				✓	✓	✓	✓	✓	✓	✓	✓	✓	✓	✓	✓	✓
Full key balancing	<b>L68</b>				✓	✓	✓	✓	✓	✓	✓	✓	✓	✓	✓	✓	✓
Balancing without key	<b>M37</b>				✓	✓	✓	✓	✓	✓	✓	✓	✓	✓	✓	✓	✓
<b>Heating and ventilation</b>																	
Anti-condensation heaters for 230 V	<b>K45</b>				✓	✓	✓	✓	✓	✓	✓	✓	✓	✓	✓	✓	✓
Anti-condensation heaters for 115 V	<b>K46</b>				✓	✓	✓	✓	✓	✓	✓	✓	✓	✓	✓	✓	✓
<b>Rating plate and extra rating plates</b>																	
Second lubricating plate, supplied loose	<b>B06</b>				–	–	✓	✓	✓	✓	✓	✓	✓	✓	✓	✓	✓
Second rating plate, loose (standard version)					□	□	□	□	□	□	□	□	□	□	□	□	□
Extra rating plate with identification code	<b>Y82 •</b> and identification code				✓	✓	✓	✓	✓	✓	✓	✓	✓	✓	✓	✓	✓
Additional information on rating plate and on package label (maximum of 20 characters)	<b>Y84 •</b> and identification code				✓	✓	✓	✓	✓	✓	✓	✓	✓	✓	✓	✓	✓
<b>Packaging, safety notes and test certificates</b>																	
Acceptance test certificate 3.1 according to EN 10204	<b>B02</b>				✓	✓	✓	✓	✓	✓	✓	✓	✓	✓	✓	✓	✓
Operating instructions German/English enclosed in print	<b>B23</b>				✓	✓	✓	✓	✓	✓	✓	✓	✓	✓	✓	✓	✓
Type test with heat run for horizontal motors, with acceptance	<b>F83</b>				✓	✓	✓	✓	✓	✓	✓	✓	✓	✓	✓	✓	✓
Wire-lattice pallet	<b>L99</b>				○	○	○	○	○	○	○	○	○	–	–	–	–

- Standard version
- Without additional charge
- ✓ With additional charge
- Not possible
- This order code only determines the price of the version – Additional plain text is required.
- . R. Possible on request

<sup>1)</sup> Evaluation with appropriate tripping unit (see Catalog LV 1) is recommended. Double the number of temperature sensors are required for pole-changing motors with separate windings. (Order code A11, price of A12 or order code A12, prices on request).

<sup>2)</sup> No additional charge with types of construction without feet: IM B5, IM V1, IM V3.

<sup>3)</sup> Supplied with the condensation drainage holes sealed at the drive end DE and non-drive end NDE for IP55, IP56 and IP65 degrees of protection. If condensation drainage holes are required in motors of the IM B6, IM B7 or IM B8 type of construction (feet located on side or top), it is necessary to relocate the bearing plates at the drive end (DE) and non-drive end (NDE) so that the condensation drainage holes situated between the feet on delivery are underneath.

# IEC Squirrel-Cage Motors

## Smoke-extraction motors

### Special versions

Special versions	Additional identification code <b>-Z</b> with order code and plain text if required	Motor type frame size														
		56	63	71	80	90	100	112	132	160	180	200	225	250	280	315
<b>Forced-air cooled motors</b>																
<b>1PP6 (cast-iron) temperature/time classes F200, F300 and F400</b>																
<b>Motor protection</b>																
Motor protection with PTC thermistors with 3 embedded temperature sensors for tripping <sup>1)</sup>	<b>A11</b>						✓	✓	✓	✓	✓	✓	✓	✓	✓	✓
Motor protection with PTC thermistors with 6 embedded temperature sensors for tripping and alarm <sup>1)</sup>	<b>A12</b>						✓	✓	✓	✓	✓	✓	✓	✓	✓	✓
Motor temperature detection with embedded temperature sensor KTY 84-130 <sup>1)</sup>	<b>A23</b>						✓	✓	✓	✓	✓	✓	✓	✓	✓	✓
Installation of 3 PT 100 resistance thermometers <sup>1)</sup>	<b>A60</b>						-	-	-	-	✓	✓	✓	✓	✓	✓
Installation of 6 PT 100 resistance thermometers in stator winding <sup>1)</sup>	<b>A61</b>						-	-	-	-	-	-	-	✓	✓	✓
Installation of 2 PT 100 screw-in resistance thermometers (basic circuit) for rolling-contact bearings <sup>1)</sup>	<b>A72</b>						-	-	-	-	✓	✓	✓	✓	✓	✓
Installation of 2 PT 100 screw-in resistance thermometers (3-wire circuit) for rolling-contact bearings <sup>1)</sup>	<b>A78</b>						-	-	-	-	✓	✓	✓	✓	✓	✓
<b>Motor connection and connection box</b>																
External earthing	<b>L13</b>						✓	✓	✓	✓	□	□	□	□	□	□
Protruding cable ends – right side <sup>2)</sup>	<b>L51</b>						✓	○	○	○	✓	✓	✓	✓	✓	✓
Protruding cable ends – left side <sup>2)</sup>	<b>L52</b>						✓	○	○	○	✓	✓	✓	✓	✓	✓
<b>Colors and paint finish</b>																
Special finish in RAL 7030 stone gray							□	□	□	□	□	□	□	□	□	□
Special finish in other standard RAL colors: RAL 1002, 1013, 1015, 1019, 2003, 2004, 3000, 3007, 5007, 5009, 5010, 5012, 5015, 5017, 5018, 5019, 6011, 6019, 6021, 7000, 7001, 7004, 7011, 7016, 7022, 7031, 7032, 7033, 7035, 9001, 9002, 9005 Page 0/18	<b>Y54 •</b> and special finish RAL .....						✓	✓	✓	✓	✓	✓	✓	✓	✓	✓
Offshore special finish	<b>M91</b>						O. R.	O. R.	O. R.	O. R.	O. R.	O. R.	O. R.	O. R.	O. R.	O. R.
Sea air resistant special finish	<b>M94</b>						O. R.	O. R.	O. R.	O. R.	O. R.	O. R.	O. R.	O. R.	O. R.	O. R.
Unpainted (only cast iron parts primed)	<b>K23</b>						○	○	○	○	○	○	○	○	○	○
Unpainted, only primed	<b>K24</b>						✓	✓	✓	✓	✓	✓	✓	✓	✓	✓
<b>Mechanical design and degrees of protection</b>																
IP65 degree of protection	<b>K50</b>						✓	✓	✓	✓	✓	✓	✓	✓	✓	✓
Condensation drainage holes <sup>3)</sup>	<b>L12</b>						✓	✓	✓	✓	□	□	□	□	□	□
Non-rusting screws (externally)	<b>M27</b>						✓	✓	✓	✓	✓	✓	✓	✓	✓	✓

# IEC Squirrel-Cage Motors

## Smoke-extraction motors

### Special versions

Special versions	Additional identification code <b>-Z</b> with order code and plain text if required	Motor type frame size															
		56	63	71	80	90	100	112	132	160	180	200	225	250	280	315	
<b>Forced-air cooled motors</b>																	
																	<b>1PP6 (cast-iron) temperature/time classes F200, F300 and F400</b>
<b>Bearings and lubrication</b>																	
Measuring nipple for SPM shock pulse measurement for bearing inspection	<b>G50</b>										✓	✓	✓	✓	✓	✓	✓
Regreasing device	<b>K40</b>										✓	✓	✓	✓	✓	✓	□
<b>Balance and vibration quantity</b>																	
Vibration quantity A											□	□	□	□	□	□	□
Vibration quantity B	<b>K02</b>										✓	✓	✓	✓	✓	✓	✓
Full key balancing	<b>L68</b>										✓	✓	✓	✓	✓	✓	✓
Balancing without key	<b>M37</b>										✓	✓	✓	✓	✓	✓	✓
<b>Heating and ventilation</b>																	
Anti-condensation heaters for 230 V	<b>K45</b>										✓	✓	✓	✓	✓	✓	✓
Anti-condensation heaters for 115 V	<b>K46</b>										✓	✓	✓	✓	✓	✓	✓
<b>Rating plate and extra rating plates</b>																	
Second lubricating plate, supplied loose	<b>B06</b>										✓	✓	✓	✓	✓	✓	✓
Second rating plate, loose (standard version)											□	□	□	□	□	□	□
Extra rating plate with identification code	<b>Y82 •</b> and identification code										✓	✓	✓	✓	✓	✓	✓
Additional information on rating plate and on package label (maximum of 20 characters)	<b>Y84 •</b> and identification code										✓	✓	✓	✓	✓	✓	✓
<b>Packaging, safety notes and test certificates</b>																	
Acceptance test certificate 3.1 according to EN 10204	<b>B02</b>										✓	✓	✓	✓	✓	✓	✓
Operating instructions German/English enclosed in print	<b>B23</b>										✓	✓	✓	✓	–	–	–
Type test with heat run for horizontal motors, with acceptance	<b>F83</b>										✓	✓	✓	✓	✓	✓	✓
Wire-lattice pallet	<b>L99</b>										○	○	○	○	–	–	–

- Standard version
- Without additional charge
- ✓ With additional charge
- Not possible
- This order code only determines the price of the version – Additional plain text is required.
- O. R. Possible on request

<sup>1)</sup> Evaluation with appropriate tripping unit (see Catalog LV 1) is recommended. For pole-changing motors with separate windings, the number of temperature sensors must be doubled. (order code A11, price of A12 or order code A12, price available on request.)

<sup>2)</sup> No additional charge with types of construction without feet: IM B5, IM V1, IM V3.

<sup>3)</sup> Supplied with the condensation drainage holes sealed at the drive end DE and non-drive end NDE for IP55, IP56 and IP65 degrees of protection. If condensation drainage holes are required in motors of the IM B6, IM B7 or IM B8 type of construction (feet located on side or top), it is necessary to relocate the bearing plates at the drive end (DE) and non-drive end (NDE) so that the condensation drainage holes situated between the feet on delivery are underneath.

# IEC Squirrel-Cage Motors

## Smoke-extraction motors

### Accessories

#### Overview

##### *Slide rails with fixing bolts and tensioning screws to DIN 42923*

Slide rails are used to tension the belt of a machine easily and conveniently when a belt tightener is not available. They are fixed to the base using stone bolts or foundation blocks.

The assignment of slide rails to motor size can be found in DIN 42923. For motors of frame sizes 355 to 450, there are no standardized slide rails (please inquire).

Available from:  
Lütgert & Co. GmbH  
Postfach 42 51  
33276 Gütersloh, Germany  
Tel. +49 (0)5241-7407-0  
Fax +49 (0)5241-7407-90

<http://www.luetgert-antriebe.de>  
e-mail: [info@luetgert-antriebe.de](mailto:info@luetgert-antriebe.de)

##### *Foundation block acc. to DIN 799*

The foundation blocks are inserted into the stone foundation and embedded in concrete. They are used for fixing machines of medium size, slide rails, pedestal bearings, baseframes, etc. After the fixing bolts have been unscrewed, the machine can be dragged without it having to be lifted.

When the machine is initially installed, the foundation block that is bolted to the machine (without washers) and fitted with taper pins is not embedded with concrete until the machine has been fully aligned. In this case, the machine is positioned 2 to 3 mm lower. The difference in shaft height is compensated by inserting shims on final installation. The taper pins safeguard the exact position of the machine when it is repeatedly removed and replaced without the need for realignment.

Available from:  
Lütgert & Co. GmbH  
Postfach 42 51  
33276 Gütersloh, Germany  
Tel. +49 (0)5241-7407-0  
Fax +49 (0)5241-7407-90

<http://www.luetgert-antriebe.de>  
e-mail: [info@luetgert-antriebe.de](mailto:info@luetgert-antriebe.de)

##### *Taper pins to DIN 258 with threaded ends and constant taper lengths*

Taper pins are used for components that are repeatedly removed. The drilled hole is ground conical using a conical reamer until the pin can be pushed in by hand until the cone shoulder lies 3 to 4 mm above the rim of the hole.

It can then be driven in using a hammer until it is correctly seated. The pin is removed from the drilled hole by screwing on the nut and tightening it.

Standardized taper pins are available from general engineering suppliers.

Available from:  
Otto Roth GmbH & Co. KG  
Rutesheimer Straße 22  
70499 Stuttgart, Germany  
Tel. +49 (0)7 11-1388-0  
Fax +49 (0)7 11-1388-233

<http://www.ottoroth.de>  
e-mail: [info@ottoroth.de](mailto:info@ottoroth.de)

##### *Couplings*

The motor from Siemens is connected to the machine or gear unit through a coupling. Flender is an important coupling manufacturer with a wide range of products. For standard applications, Siemens recommends that elastic couplings of Flender types N-Eupex and Rupex or torsionally rigid couplings of types Arpex and Zapex are used. For special applications, Fludex and Elpex couplings are recommended.

Source of supply:  
Siemens contact partner – ordering from Catalog  
Siemens MD 10.1 „FLENDER Standard Couplings“

or

A. Friedr. Flender AG  
Kupplungswerk Mussum  
Industriepark Bocholt  
Schlavenhorst 100  
46395 Bocholt, Germany  
Tel. +49 (0)2871-922185  
Fax +49 (0)2871-922579

<http://www.flender.com>  
e-mail: [couplings@flender.com](mailto:couplings@flender.com)

#### More information

##### *Spare motors and repair parts*

- Supply commitment for spare motors and repair parts following delivery of the motor
  - For up to 5 years, in the event of total motor failure, Siemens will supply a comparable motor with regard to the mounting dimensions and functions (the type series may vary).
  - Repair parts will be supplied for up to 5 years.
  - For up to 10 years, Siemens will provide information and will, if necessary, supply documentation for repair parts.
- When repair parts are ordered, the following details must be provided:
  - Designation and part number
  - Order No. and factory number of the motor

Example for ordering a fan cover 1LA7,  
frame size 160 M, 4-pole:

**Fan cover No. 7.40,  
1LA7 163-4AA60, factory number J783298901018**

- For bearing types, see the “Introduction”.
- Repair parts for 1MJ6, 1MJ7, 1MJ8, 1MJ1, 1ME8, 1ML8, 1LG8 motors and smoke-extraction motors are available on request.
- For standard components, a supply commitment does not apply.
- Support – Hotline  
In Germany  
Tel.: 0180/5050448

National telephone numbers can be found on the Internet page:  
<http://www.siemens.com/automation/service&support>



# IEC Squirrel-Cage Motors

## Smoke-extraction motors

### Dimensions

#### Overview

#### Overall dimensions

The overall dimensions of the smoke-extraction motors are listed below. The relevant dimensional drawings can be ordered.

Dimension O is not specified because the motors are connected to the supply by means of protruding multi-core cables.

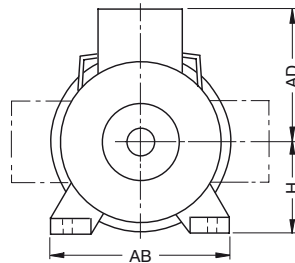
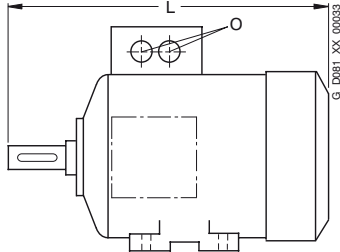

Frame size	Type	Dimensions			
		L	AD <sup>1)</sup>	H	AB
80 M	1LA7 08.-.T...	274	100	80	150
	1PP7 08.-.T...	240	100	80	150
90 S/ 90 L	1LA7 09.-.T...	332	107	90	165
	1PP7 09.-.T...	240	107	90	165
100 L	1LA6 10.-.U...	373	120	100	196
	1LA7 10.-.T...	373	120	100	196
	1PP6 10.-.U...	335	120	100	196
	1PP7 10.-.T...	335	120	100	196
112 M	1LA6 11.-.U...	394	128	112	226
	1LA7 11.-.T...	394	128	112	226
	1PP6 11.-.U...	354	128	112	226
	1PP7 11.-.T...	354	128	112	226
132 S/ 132 M	1LA6 13.-0U...	454	148	132	256
	1LA6 13.-1UD..	454	148	132	256
	1LA6 13.-2UA..	454	148	132	256
	1LA6 13.-4UA..	454	148	132	256
	1LA6 13.-6UA..	492	148	132	256
	1LA7 13.-.T...	454	148	132	256
	1PP6 13.-0U...	403	148	132	256
	1PP6 13.-1UD..	403	148	132	256
	1PP6 13.-2UA..	403	148	132	256
	1PP6 13.-4UA..	403	148	132	256
	1PP6 13.-6UA..	443	148	132	256
	1PP7 13.-.T...	403	148	132	256
160 M/ 160 L	1LA6 16.-0U...	588	170	160	300
	1LA6 16.-1UD..	588	170	160	300
	1LA6 16.-2UA..	588	170	160	300
	1LA6 16.-4UA..	588	170	160	300
	1LA6 16.-6UA..	628	170	160	300
	1LA7 16.-.T...	588	170	160	300
	1PP6 16.-0U...	535	170	160	300
	1PP6 16.-1UD..	535	170	160	300
	1PP6 16.-2UA..	535	170	160	300
	1PP6 16.-4UA..	535	170	160	300
	1PP6 16.-6UA..	575	170	160	300
	1PP7 16.-.T...	535	170	160	300

Frame size	Type	Dimensions			
		L	AD <sup>1)</sup>	H	AB
180 M/ 180 L	1LA5 18.-.T...	712	243	180	339
	1LG6 183-2UA..	720	244	180	339
	1LG6 183-4UA..	669	244	180	339
	1LG6 186-.UA..	720	244	180	339
	1PP5 18.-.T...	611	243	180	339
	1PP6 183-2UA..	613	244	180	339
200 L	1PP6 183-4UA..	562	244	180	339
	1PP6 186-.UA..	613	244	180	339
	1LA5 20.-.T...	770	292	200	388
	1LG6 206-.UA..	720	285	200	378
	1LG6 207-2UA..	777	285	200	378
	1LG6 207-4UA..	720	285	200	378
225 S/ 225 M	1LG6 207-6UA..	777	285	200	378
	1PP5 20.-.T...	675	292	200	388
	1PP6 206-.UA..	617	285	200	378
	1PP6 207-2UA..	674	285	200	378
	1PP6 207-4UA..	617	285	200	378
	1PP6 207-6UA..	674	285	200	378
	1LA5 220-4TA..	807	292	225	426
	1LA5 223-2TA..	777	292	225	426
	1LA5 223-4TA..	807	292	225	426
	1LA5 223-6TA..	807	292	225	426
	1LG6 220-4UA..	789	310	225	436
	1LG6 223-2UA..	819	310	225	436
1LG6 223-4UA..	849	310	225	436	
1LG6 223-6UA..	849	310	225	436	
250 M	1PP5 220-4TA..	711	292	225	426
	1PP5 223-2TA..	681	292	225	426
	1PP5 223-4TA..	711	292	225	426
	1PP5 223-6TA..	711	292	225	426
	1PP6 220-4UA..	670	310	225	436
	1PP6 223-2UA..	700	310	225	436
	1PP6 223-4UA..	730	310	225	436
	1LG6 253-2.B..	887	340	250	490
	1LG6 253-4.A..	957	340	250	490
	1LG6 253-6.A..	887	340	250	490
	1PP6 253-2....	764	340	250	490
	1PP6 253-4....	834	340	250	490
	1PP6 253-6....	764	340	250	490

<sup>1)</sup> Dimension AD without cable gland.

# IEC Squirrel-Cage Motors

## Smoke-extraction motors

### Dimensions

#### Overview (continued)

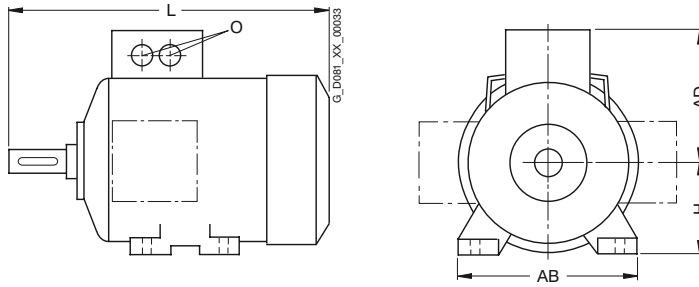

Frame size	Type	Dimensions				
		L	AD <sup>1)</sup>	H	AB	
280 S/ 280 M	1LG6 280-.....	960	378	280	540	
	1LG6 283-2....	1070	378	280	540	
	1LG6 283-4....	1070	378	280	540	
	1LG6 283-6....	960	378	280	540	
	1PP6 280-.....	830	378	280	540	
	1PP6 283-2....	940	378	280	540	
	1PP6 283-4....	940	378	280	540	
	1PP6 283-6....	830	378	280	540	
	315 S/ 315 M/ 315 L	1LG6 310-2.B..	1072	440	315	610
		1LG6 310-4.A..	1102	440	315	610
1LG6 310-6.A..		1102	440	315	610	
1LG6 313-2.B..		1232	440	315	610	
1LG6 313-4.A..		1262	440	315	610	
1LG6 313-6.A..		1262	440	315	610	
1LG6 316-2.B..		1232	440	315	610	
1LG6 316-4.A..		1262	440	315	610	
1LG6 316-4.B..		1262	440	315	610	
1LG6 316-6.A..		1262	440	315	610	
1LG6 317-2.B..		1372	440	315	610	
1LG6 317-4.A..		1402	440	315	610	
1LG6 317-6.A..		1402	440	315	610	
1LG6 318-6.A..		1402	440	315	610	

Frame size	Type	Dimensions			
		L	AD <sup>1)</sup>	H	AB
315 S/ 315 M/ 315 L	1PP6 310-2.B..	925	440	315	610
	1PP6 310-4.A..	955	440	315	610
	1PP6 310-6.A..	955	440	315	610
	1PP6 313-2.B..	1085	440	315	610
	1PP6 313-4.A..	1115	440	315	610
	1PP6 313-6.A..	1115	440	315	610
	1PP6 316-2.B..	1085	440	315	610
	1PP6 316-4.A..	1115	440	315	610
	1PP6 316-6.A..	1115	440	315	610
	1PP6 317-2.B..	1225	440	315	610
	1PP6 317-4.A..	1255	440	315	610
	1PP6 317-6.A..	1255	440	315	610
	1PP6 318-6.A..	1255	440	315	610

<sup>1)</sup> Dimension AD without cable gland.

## Marine motors



<b>10/2</b>	<b>Orientation</b>
10/2	Overview
10/3	Benefits
10/3	Application
10/3	Technical specifications
10/5	More information
<b>10/6</b>	<b>Type approved standard motors up to frame size 315 L</b>
10/6	Overview
<b>10/7</b>	<b>Type approved explosion-proof motors up to frame size 315 L</b>
10/7	Overview
<b>10/7</b>	<b>Type approved fan motors</b>
10/7	Overview
<b>10/8</b>	<b>Standard motors up to frame size 315 L (individual acceptance required)</b>
10/8	Overview
<b>10/8</b>	<b>Smoke-extraction motors (individual acceptance required)</b>
10/8	Overview
<b>10/9</b>	<b>Non-standard motors frame size 315 and above (individual acceptance required)</b>
10/9	Overview
<b>10/9</b>	<b>Explosion-proof motors frame size 315 and above (individual acceptance required)</b>
10/9	Overview
<b>10/10</b>	<b>Special versions</b>
10/10	Overview
10/10	Selection and ordering data
<b>10/25</b>	<b>Accessories</b>
10/25	Overview
<b>10/25</b>	<b>Dimensions</b>
10/25	Overview

# IEC Squirrel-Cage Motors

## Marine motors

### Orientation

### Overview



Low-voltage motors in the marine version can be used as main and auxiliary drives below deck on ships and in the offshore industry. The thermal utilization of the motors is matched to the generally higher ambient temperatures on board ship. If the application demands compliance with additional regulations, e.g. protection against explosion hazards, the appropriate motor series must be chosen.

The classification authorities categorize the drives on board ships into "essential services" and "non-essential services", depending on their field of application. These include the following requirements of the classification authorities:

	Drives for "essential services"	Drives for "non-essential services"
Manufacture in accordance with regulations of the classification authorities	Required	Required
Acceptance test certificate 3.1 according to EN 10204	Required	Only required for motors with certificate
Type test certificate of the classification authority	Required up to a certain limit power	Not required
Individual acceptance test by classification authority	Required above a specific output	Only required for motors with certificate
Supervision of construction and acceptance test certificate 3.2 according to EN 10204	Required by some classification authorities above a specific output	Not required

### Type test

All motors (with the exception of 1LA8, 1PQ8, 1LL8 and 1LH8 motors) are manufactured and type approved in accordance with the regulations of the following leading international classification authorities:

- GL (Germanischer Lloyd, Germany)



Germanischer Lloyd

- DNV (Det Norske Veritas, Norway)



- LR (Lloyds Register, United Kingdom)



- BV (Bureau Veritas, France)

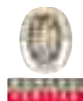

Individual acceptance testing is required in general for motor series 1LA8, 1PQ8, 1LL8 and 1LH8.

As an option, we can manufacture motors in accordance with the following classification authorities:

- ABS (American Bureau of Shipping, USA)
- RINA (Registro Italiano Navale, Italy)
- CCS (Chinese Classification Society, China)

A type test certificate will however only be issued following individual acceptance testing.

Special versions that differ from the range defined in the Catalog are possible on request.

### Individual acceptance and supervision of construction

Individual acceptance testing by a representative of the relevant classification authority is required for motors used in essential auxiliary drives, depending on their output:

- GL  $\geq 50$  kW
- LR  $\geq 100$  kW
- DNV  $\geq 300$  kW
- BV  $\geq 100$  kW

For individual acceptance testing of more than one identical motor in an order, a type test complete with heat run and the corresponding acceptance test must be performed for at least one motor.

In special cases, in addition to the acceptance test, supervision of construction may also be required. Supervision of construction involves monitoring of the separate manufacturing stages of a motor by an inspector from the classification authority.

### Benefits

The marine motors offer the user a number of advantages:

- Cast-iron versions can be supplied for corrosive atmospheres especially for high humidity levels and salty air
- Increased corrosion protection using specially designed paint finishes is available
- Certified marine motors can be supplied for use in areas to be protected against explosion

- Due to the type tests already performed, individual acceptance testing in the low-end output range is not necessary which means shorter delivery times
- Distinctive expertise for customer requirements
- Worldwide service network with 24 h service hotline for motors and converters (Tel.: +49 180 173 7373; e-mail: [shipservice@siemens.com](mailto:shipservice@siemens.com))

### Application

Our type approved marine motors are specially designed for use on board ship below deck and for the offshore industry:

- Applications on board ship as main and auxiliary drives below deck, e.g.:
  - Fans (air conditioning, refrigeration plants)
  - Pumps (for fire-extinguishing water, fuels, oils)
  - Winches (anchor winches, warping winches, lifting gear)
  - Compressors
  - Bow thruster drives
  - Ex motors for areas subject to explosion hazards
- Application in the offshore industry
  - Coastal areas, e.g. production platforms, production ships

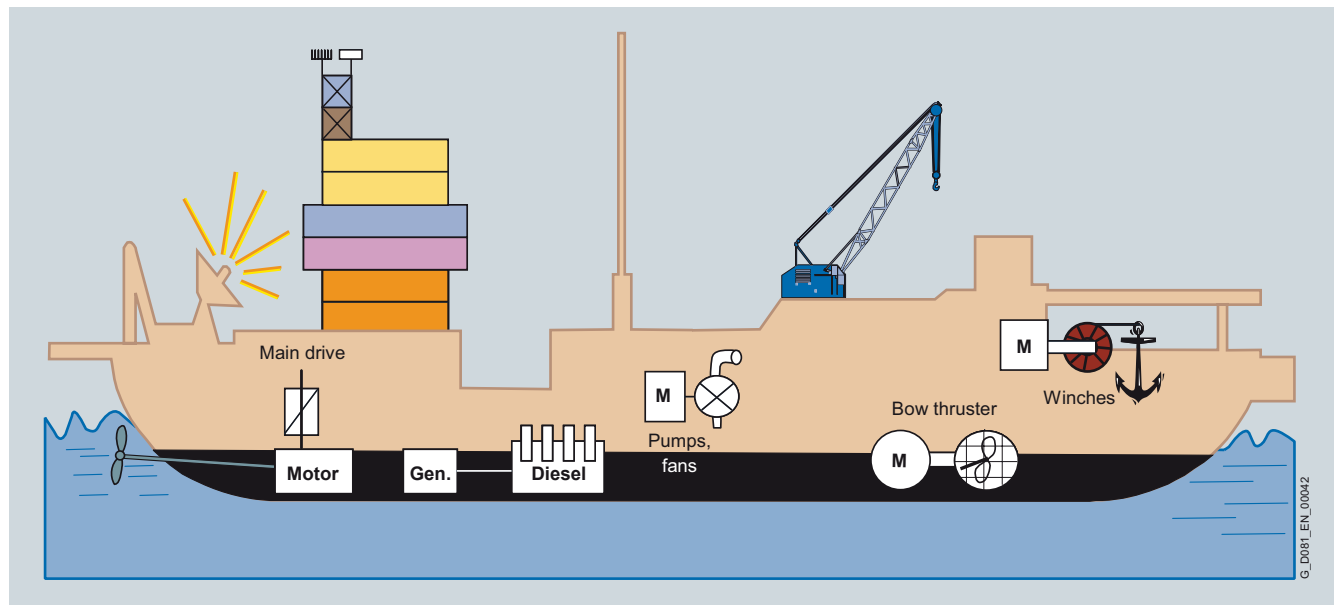

Typical areas of application

### Technical specifications

#### Frame design

Motors can be supplied depending on the motor series in a corrosion-resistant aluminum housing and in a rugged low-vibration cast-iron version.

#### Motor connection

Cable glands are not included in the standard scope of supply with the exception of explosion-proof motors (see "Special versions").

All marine motors generally have an external earthing terminal.

#### Standards and specifications

In addition to the relevant standards and regulations, IEC 92-301 also applies for electrical installation on board ship as well as the regulations of the marine classification authorities.

#### Specifications of the IEC standards

	Coolant temperature CT	Admissible temperature for temperature class	
		130 (B) CI	155 (F) CI
IEC/EN 60034-1	40	80	105
IEC 92-301	50	70	90

# IEC Squirrel-Cage Motors

## Marine motors

### Orientation

#### Technical specifications (continued)

Specifications of the individual classification authorities with order codes for ordering

Classification authorities	Coolant temperature CT	Admissible temperature for relevant classification authorities		Individual acceptance for "essential services" drive	Supervision of construction for "essential services" drive	Order codes for surface-cooled motors up to frame size 315L		Order codes for surface-cooled motors frame size 315 and above		
		Temperature class 130 (B)	155 (F)			Required from a rated output	Required from a rated output	Without type test certificate	Without type test certificate	Without type test certificate
	°C	CI	CI	kW	kW					
<b>GL</b>	45	75	100	≥ 50	–	<b>E11</b>	–	<b>E11</b>	<b>E11+E10</b>	<b>E11+E09</b>
<b>LR</b>	45	70	95	≥100	≥100	<b>E21</b>	–	<b>E21</b>	<b>E21+E10</b>	<b>E21+E09</b>
<b>BV</b>	45	75	100	≥100	–	<b>E31</b>	–	<b>E31</b>	<b>E31+E10</b>	<b>E31+E09</b>
<b>DNV</b>	45	75	100	≥300	–	<b>E51</b>	–	<b>E51</b>	<b>E51+E10</b>	<b>E51+E09</b>
<b>ABS</b>	50	70	95	≥100	≥100	–	<b>E00</b>	<b>E61</b>	<b>E61+E10</b>	<b>E61+E09</b>
<b>RINA</b>	45	75	95	≥100	–	–	<b>E00</b>	–	–	–
<b>CCS</b>	45	75	100	≥100	–	–	<b>E00</b>	<b>E71</b>	<b>E71+E10</b>	<b>E71+E09</b>

#### Type test certificates



### Technical specifications (continued)

#### Temperature class and coolant temperature

Marine motors are designed in general for a coolant temperature CT 45 °C in temperature class 155 (F) – used according to 155 (F) – with thermal reserve. When used according to temperature class 130 (B), order code **C22**, derating of approximately 4 % (for order codes **E00** and **E21** approximately 8 %) necessary.

1MA and 1MJ motors as well as motors in Zones 2, 21 and 22 are designed in temperature class 155 (F) – used according to temperature class 130 (B) – with derating of approximately 4 % (for order code **E00** approximately 8 %). 1MA motors are designed for the maximum possible and certified outputs.

1LA9 motors with increased output in temperature class 155 (F) – used according to temperature class 155 (F) – are also derated by approximately 4 % (for order code **E00/E21** approximately 8 %).

If temperature class 155 (F) is used according to 130 (B), further derating of approximately 10 % (for non-standard motors 1LA8, 1PQ8 15 %) is required.

Please inquire for further details.

Coolant temperatures that exceed 45 °C require appropriate derating as shown in the table below:

Derating factor	Coolant temperature CT (for temperature class 155 (F) used according to 155 (F))			
	45 °C	50	55	60
	1.00	0.96	0.92	0.87

#### Rating plate and acceptance test certificate

The metal rating plate indicates the relevant classification authority and the associated coolant temperature.

<b>SIEMENS</b>		3-Mot. 1LA91662KA60 - Z		IEC / EN 60034		(H)	
D-91056 Erlangen		E 0107 / 471101 02 003		120 kg IM B3		160 L IP55 Th.Cl.155 (F) <b>Amb 45 °C</b> CE	
50 Hz		400 / 690 V Δ/Y		<b>DNV</b>		60 Hz 460 V Δ	
○ 18.5 kW		31.5 / 18.2 A		PF 0.92		18.5 kW 27.7 A ○	
cos φ 0.92		2940 / min		NEMA Nom. Eff 91.0%		25.0 Hp	
380-420 / 660-725 V Δ/Y		Space heater 230 V		Design A Code J CC 032 A		NEMA MG1-12 CONT	
34.0-30.5 / 19.6-17.6 A		Severity R					

Rating plate for a marine motor according to DNV

In addition, an acceptance test certificate 3.1 according to EN 10204 complete with the certificate number of the marine classification authority will be supplied.

### More information

For more information, please contact your local Siemens contact – see “Siemens Contacts Worldwide” in the Appendix.

#### Degree of protection

The standard version is IP55 degree of protection or IP23 for motors with through ventilation (series 1LL8), IP56 (non-heavy sea) – not for 1PQ8 and 1LL8) or IP65 (not possible for “Non-standard motors frame size 315 and above”) are available optionally (see “Special versions”).

#### Winding and motor protection

For monitoring the winding and bearings, the motors can be equipped with thermistors, temperature sensors and resistance thermometers. Anti-condensation heaters can also be fitted to the marine motors to prevent condensation building up on the winding.

#### Paint finish

The standard paint finish is suitable for indoor installations or outdoor installations which are roof-protected against weathering.

When standard motors are installed in sea atmospheres or in rooms that are constantly wet, the special paint finish for the “world wide” climatic group according to DIN IEC 60721-2-1 is suitable because this ensures a higher degree of corrosion protection. Most marine motors are finished in this special paint type as standard (see “Special versions”).

The sea air resistant special finish (order code **M94**) or the Off-shore special finish (order code **M91**) are recommended for excessively aggressive atmospheres.

Special finish with thicker layers are available on request.

#### Converter-fed operation

The standard insulation of the marine motors is implemented such that converter-fed operation is possible without limits for mains voltages of 460 V (for motor series 1LA8, 1PQ8, 1LL8 and 1LH8 up to 500 V) +10 %; exception: 1MA motors are only certified for mains operation.

At higher voltages, the motors require greater insulation resistance.

1LA5, 1LA7 and 1LG6 standard motors as well as 1LA8 and 1PQ8 non-standard motors are also available for converter-fed operation with supply voltages of up to 690 V also with improved insulation in the winding system.

It is important to note the extent to which the converter used must also be acceptance tested by the marine classification authority.

# IEC Squirrel-Cage Motors

## Marine motors

### Type approved standard motors up to frame size 315 L

#### Overview

Most standard motors of Siemens AG can be used as marine motors if the appropriate order codes are used. The following table shows the standard motor series that are available with type testing up to frame size 315 L:

Motor type	Standard degree of protection	Frame design	Motor series <sup>1)</sup>	Motor frame sizes	Output range in kW Output data for mains-fed operation 50 Hz at CT 45 °C in temperature class 155 (F), used according to 155 (F).
Self-ventilated motors with improved efficiency	IP55	Aluminum	1LA7	56 M ... 160 L	0.06 ... 18.5
			1LA5	180 M ... 225 M	11 ... 45
		Cast-iron	1LA6	100 L ... 160 L	0.75 ... 18.5
			1LG4	180 M ... 315 L	11 ... 200
Self-ventilated motors with high efficiency	IP55	Aluminum	1LA9	56 M ... 200 L	0.06 ... 37
		Cast-iron	1LG6	180 M ... 315 L	11 ... 200

The type approved and self-cooled motor series 1LP4, 1LP5, 1LP6 and 1LP7 in frame sizes 63 M to 315 L with derating without external fan and fan cover can be supplied on request.

**For technical specifications and selection and ordering data, see the relevant sections of "Standard motors up to frame size 315 L".**

#### Ordering example:

Selection criteria	Requirement	Structure of the Order No.
Motor type	Standard motor with improved efficiency, IP55 degree of protection, cast-iron version	<b>1LG4</b>
No. of poles/speed	4-pole/1500 rpm	<b>1LG4253-4AA</b>
Rated output	55 kW	
Voltage and frequency	400 VΔ/690 VY, 50 Hz	<b>1LG4253-4AA6</b>
Type of construction	IM B3	<b>1LG4253-4AA60</b>
Paint finish	Special paint finish in RAL 5007	<b>1LG4253-4AA60-Z</b> <b>Y54</b> <b>Plain text: RAL 5007</b>
Marine version	Drive for "essential services" with type test certificate according to Germanischer Lloyd with coolant temperature CT 45 °C	<b>1LG4253-4AA60-Z</b> <b>Y54+E11</b> Plain text: RAL 5007
	Individual acceptance (by marine classification society)	<b>1LG4253-4AA60-Z</b> <b>Y54+E11+E10</b> Plain text: RAL 5007
	Type test with heat run for horizontal motors, with acceptance	<b>1LG4253-4AA60-Z</b> <b>Y54+E11+E10+F83</b> Plain text: RAL 5007

The ordering example is valid for an order quantity of 1 item. For larger order quantities, a type test with heat run (order code **F83**) only has to be ordered for one motor. For all other identical motors, order code F83 is not required. The order must be subdivided into two order items.

#### Example for ordering 5 items:

Order item	Quantity (items)	Order No.
1	1	<b>1LG4253-4AA60-Z</b> <b>Y54+E11+E10+F83</b> Plain text: RAL 5007
2	4	<b>1LG4253-4AA60-Z</b> <b>Y54+E11+E10</b> Plain text: RAL 5007

For further information about ordering codes see "Special versions".

<sup>1)</sup> For 1LA9 motors with increased output, derating is necessary. Please contact your local Siemens office for advice.



# IEC Squirrel-Cage Motors

## Marine motors

Type approved explosion-proof motors  
up to frame size 315 L

### Overview

Most explosion-proof motors up to frame size 315 L from Siemens AG can be used as marine motors if ordered with the relevant order codes. The following table shows the series of explosion-proof motors that are available with type testing up to frame size 315 L:

Motor type	Standard degree of protection	Frame design	Motor series <sup>1)</sup>	Motor frame sizes	Output range in kW Output data for mains-fed operation 50 Hz at CT 45 °C in temperature class 155 (F), used according to 155 (F).
Self-ventilated motors in <b>Zone 1</b> with type of protection "e" (Zone 1 Exe II T3)	IP55	Aluminum	1MA7	63 M ... 160 L	0.12 ... 16
		Cast-iron	1MA6	100 L ... 315 L	1.3 ... 165
Self-ventilated motors in <b>Zone 1</b> with type of protection "d" (Zone 1 Exde IIC T4)	IP55	Cast-iron	1MJ6	71 M ... 200 L	0.25 ... 37
			1MJ7	225 S ... 315 M	30 ... 132
Self-ventilated motors in <b>Zone 2</b> with type of protection "n"	IP55	Aluminum	1LA7	63 M ... 160 L	0.09 ... 18.5
			1LA9	63 M ... 160 L	0.12 ... 18.5
		Cast-iron	1LA6	100 L ... 160 L	0.75 ... 18.5
			1LG4/1LG6	180 M ... 315 L	11 ... 200
Self-ventilated motors in <b>Zone 21</b> with protection against dust explosions	IP55	Aluminum	1LA7	56 M ... 160 L	0.06 ... 18.5
			1LA5	180 M ... 225 M	11 ... 45
			1LA9	56 M ... 200 L	0.06 ... 37
		Cast-iron	1LG4/1LG6	180 M ... 315 L	11 ... 200
Self-ventilated motors in <b>Zone 22</b> with protection against dust explosions	IP55	Aluminum	1LA7	56 M ... 160 L	0.06 ... 18.5
			1LA5	180 M ... 225 M	11 ... 45
			1LA9	56 M ... 200 L	0.06 ... 37
		Cast-iron	1LA6	100 L ... 160 L	0.75 ... 18.5
			1LG4/1LG6	180 M ... 315 L	11 ... 200

**For technical specifications and selection and ordering data, see the relevant sections of "Explosion-proof motors".**

For further information about order codes see "Special versions".

### Type approved fan motors

### Overview

Most fan motors of Siemens AG can be used as marine motors if the appropriate order codes are used. The following table shows the series of fan motors that are available with type testing:

Motor type	Standard degree of protection	Frame design	Motor series	Motor frame sizes	Output range in kW Output data for mains-fed operation 50 Hz at CT 45 °C in temperature class 155 (F), used according to 155 (F).
Self-ventilated motors in pole-changing version	IP55	Aluminum	1LA7	80 M ... 160 L	0.15 ... 17
			1LA5	180 M ... 200 L	3 ... 28
		Cast-iron	1LG4	180 M ... 315 L	4.5 ... 175
Forced-air cooled motors without external fan and fan cover	IP55	Aluminum	1PP7	63 M ... 160 L	0.09 ... 18.5
			1PP5	180 M ... 200 L	11 ... 37
		Cast-iron	1PP4	180 M ... 315 L	11 ... 200

**For technical specifications and selection and ordering data, see the relevant sections of "Fan motors".**

For further information about order codes see "Special versions".

<sup>1)</sup> With explosion-proof motors, derating is necessary. Please contact your local Siemens office for advice.

# IEC Squirrel-Cage Motors

## Marine motors

### Standard motors up to frame size 315 L (individual acceptance required)

#### Overview

Most standard motors of Siemens AG can be used as marine motors if the appropriate order codes are used. The following table shows the series of self-cooled standard motors that are available with derating without an external fan and without a fan cover:

Motor type	Standard degree of protection	Frame design	Motor series	Motor frame sizes	Output range in kW Output data for mains-fed operation 50 Hz at CT 45 °C in temperature class 155 (F), used according to 155 (F).
Self-cooled motors without external fan	IP55	Aluminum	1LP7	63 M ... 160 L	0.045 ... 7
			1LP5	180 M ... 200 L	5.5 ... 16.5
		Cast-iron	1LP4	180 M ... 315 L	3.7 ... 67

**For technical specifications and selection and ordering data, see the relevant sections of “Standard motors up to frame size 315 L”.**

For further information about order codes see “Special versions”.

### Smoke-extraction motors (individual acceptance required)

#### Overview

Most smoke-extraction motors of Siemens AG can be used as marine motors if the appropriate order codes are used. The following table shows the available series of self-ventilated motors and forced-air cooled motors:

Motor type	Standard degree of protection	Frame design	Motor series	Motor frame sizes	Output range in kW Output data for mains-fed operation 50 Hz.
<b>Temperature/time classes F200 and F300</b>					
Self-ventilated motors	IP55	Aluminum	1LA7	80 M ... 160 L	0.09 ... 18.5
			1LA5	180 M ... 225 M	4.05 ... 45
		Cast-iron	1LG6	250 M ... 315 L	37 ... 200
Forced-air cooled motors	IP55	Aluminum	1PP7	80 M ... 160 L	0.09 ... 18.5
			1PP5	180 M ... 225 M	4.05 ... 45
		Cast-iron	1PP6	250 M ... 315 L	37 ... 200
<b>Temperature/time class F400</b>					
Self-ventilated motors	IP55	Cast-iron	1LA6	100 L ... 160 L	0.3 ... 22
			1LG6	180 M ... 315 L	15 ... 200
Forced-air cooled motors	IP55	Cast-iron	1PP6	100 L ... 315 L	0.3 ... 200

**For technical specifications and selection and ordering data, see the relevant sections of “Smoke-extraction motors”.**

For further information about order codes see “Special versions”.

# IEC Squirrel-Cage Motors

## Marine motors

Non-standard motors frame size 315 and above  
(individual acceptance required)

### Overview

Most non-standard motors frame size 315 and above of Siemens AG can be used as marine motors if the appropriate order codes are used. The following table shows the available series of non-standard motors frame size 315 and above (individual acceptance required):

Motor type	Standard degree of protection	Frame design	Motor series	Motor frame sizes	Output range in kW Output data for mains-fed operation 50 Hz at CT 45 °C in temperature class 155 (F), used according to 155 (F).
Self-ventilated motors for mains-fed and converter-fed operation	IP55	Cast-iron	1LA8	315 ... 450	160 ... 1000 <sup>1)</sup>
Forced-air cooled motors with mounted separately driven fan for converter-fed operation	IP55	Cast-iron	1PQ8	315 ... 450	160 ... 1000 <sup>1)</sup>
Self-ventilated motors with through ventilation for mains-fed and converter-fed operation	IP23	Cast-iron	1LL8	315 ... 450	200 ... 1250 <sup>1)</sup>
Water-cooled motors for mains-fed and converter-fed operation	IP55	Steel	1LH8	450	485 ... 1150 <sup>1)</sup>

Motor series 1LH8 (please inquire).

**For technical specifications and selection and ordering data, see the relevant sections of “Non-standard motors frame size 315 and above”.**

For further information about order codes see “Special versions”.

Explosion-proof motors frame size 315 and above  
(individual acceptance required)

### Overview

Most explosion-proof motors frame size 315 and above of Siemens AG can be used as marine motors if the appropriate order codes are used. The following table shows the available series of explosion-proof motors frame size 315 and above (individual acceptance required):

Motor type	Standard degree of protection	Frame design	Motor series	Motor frame sizes	Output range in kW Output data for mains-fed operation 50 Hz at CT 45 °C in temperature class 155 (F)
Self-ventilated motors in <b>Zone 2</b> with type of protection “n”	IP55	Cast-iron	1LA8	315 ... 450	160 ... 1000 <sup>2)</sup>
Self-ventilated motors in <b>Zone 22</b> with protection against dust explosions	IP55	Cast-iron	1LA8	315 ... 450	160 ... 1000 <sup>1)</sup>

**For technical specifications and selection and ordering data, see the relevant sections of “Explosion-proof motors”.**

For further information about order codes see “Special versions”.

<sup>1)</sup> At a coolant temperature of 45 °C when used according to temperature class 155 (F), the output is reduced by 4 %.

<sup>2)</sup> At a coolant temperature of 45 °C, the output is reduced by 4 %. When used according to with temperature class 130 (B), the output is reduced by a further 15 %.

# IEC Squirrel-Cage Motors

## Marine motors

### Special versions

#### Overview

##### Recommended special versions:

- Motor protection with PTC thermistors with 3 embedded temperature sensors for tripping – Order code **A11**
- Mounting of PT 100 resistance thermometers for winding temperature monitoring – Order codes **A60, A61**
- Specially for motor series 1LA8, 1PQ8 and 1LL8: Mounting of 2 screw-in PT 100 resistance thermometers in basic circuit for roller bearings – Order code **A72**
- Anti-condensation heaters for 230 V – Order code **K45**
- Anti-condensation heaters for 115 V – Order code **K46**

- IP56 degree of protection (non-heavy-sea) for protection against harmful dust deposits, protection against water jets from any direction – Order code **K52**
- IP65 degree of protection for complete protection against dust deposits, protection against water jets from any direction – Order code **K50**  
Not possible for non-standard motors 1LA8, 1PQ8 and 1LL8.
- Special bearing for drive-end (DE) and non-drive-end (NDE) bearing size 63 – Order code **K36**, for non-standard motors on request
- Metal external fan for self-ventilated motors – Order code **K35**

#### Selection and ordering data

##### Order information

The fees levied by the classification authorities for individual acceptance testing are included in order code **E09/E10** for motor types 1LG4, 1LG6, 1PP4, 1LA8, 1PQ8, 1LL8 and 1LH8. For the other motor types, 1LA5, 1LA6, 1LA7, 1LA9, 1MA, 1MJ, 1PP5, 1PP7, individual acceptance testing must be ordered in plain text and will be invoiced separately (please inquire).

When ordering, add the supplement “-Z” to the Order No. as well as plain text details. For 1LA8 motors, supplement the Order No. with order code **E80** and plain text.

For other special versions, see the relevant sections under “Standard motors up to frame size 315 L”, “Non-standard motors frame size 315 and above”, “Explosion-proof motors” and “Fan motors”. In addition to this, for marine motors, the following special versions are the Standard version and therefore included in the order codes for the basic marine version.

##### Standard version:

Description	Order code
Acceptance test certificate 3.1 according to EN 10204 (not included in order code E00)	<b>B02</b>
External earthing terminal	<b>L13</b>

#### Type approved standard motors up to frame size 315 L in marine version

Special versions	Additional identification code <b>-Z</b> with order code or plain text	Motor type frame size														
		56	63	71	80	90	100	112	132	160	180	200	225	250	280	315
		<b>1LA7 (aluminum)</b>						<b>1LA5 (aluminum)</b>								
<b>Basic marine version <sup>1)</sup></b>																
Without type test certificate according to ABS 50 °C/CCS 45 °C/RINA 45 °C, temperature class 155 (F) used according to 155 (F) (if acceptance test certificate 3.1 according to EN 10204 is required, this must be ordered with the additional order code <b>B02</b> )	<b>E00</b>	✓	✓	✓	✓	✓	✓	✓	✓	✓	✓	✓	✓	✓	✓	✓
With type test certificate according to GL (Germanischer Lloyd), Germany, CT 45 °C, temperature class 155 (F), used according to 155 (F)	<b>E11</b>	✓	✓	✓	✓	✓	✓	✓	✓	✓	✓	✓	✓	✓	✓	✓
With type test certificate according to LR (Lloyds Register), Great Britain, CT 45 °C, temperature class 155 (F), used according to 155 (F)	<b>E21</b>	✓	✓	✓	✓	✓	✓	✓	✓	✓	✓	✓	✓	✓	✓	✓
With type test certificate according to BV (Bureau Veritas), France, CT 45 °C, temperature class 155 (F), used according to 155 (F)	<b>E31</b>	✓	✓	✓	✓	✓	✓	✓	✓	✓	✓	✓	✓	✓	✓	✓
With type test certificate according to DNV (Det Norske Veritas), Norway, CT 45 °C, temperature class 155 (F), used according to 155 (F)	<b>E51</b>	✓	✓	✓	✓	✓	✓	✓	✓	✓	✓	✓	✓	✓	✓	✓
<b>Acceptance/certification</b>																
Individual acceptance by marine classification society	<b>E10</b>	✓	✓	✓	✓	✓	✓	✓	✓	✓	✓	✓	✓	✓	✓	✓
Type test with heat run for horizontal motors, with acceptance	<b>F83 <sup>2)</sup></b>	✓	✓	✓	✓	✓	✓	✓	✓	✓	✓	✓	✓	✓	✓	✓
Type test with heat run for vertical motors, with acceptance	Details in plain text <sup>2)</sup>	O. R.	O. R.	O. R.	O. R.	O. R.	O. R.	O. R.	O. R.	O. R.	O. R.	O. R.	O. R.	O. R.	O. R.	O. R.

For legend and footnotes, see Page 10/12.

# IEC Squirrel-Cage Motors

## Marine motors

### Special versions

Special versions	Additional identification code <b>-Z</b> with order code or plain text	Motor type frame size														
		56	63	71	80	90	100	112	132	160	180	200	225	250	280	315
<b>Self-ventilated energy-saving motors with improved efficiency</b>																
<b>Basic marine version <sup>1)</sup></b>																
Without type test certificate according to ABS 50 °C/CCS 45 °C/RINA 45 °C, temperature class 155 (F) used according to 155 (F) (if acceptance test certificate 3.1 according to EN 10204 is required, this must be ordered with the additional order code <b>B02</b> )	<b>E00</b>															
With type test certificate according to GL (Germanischer Lloyd), Germany, CT 45 °C, temperature class 155 (F), used according to 155 (F)	<b>E11</b>															
With type test certificate according to LR (Lloyds Register), Great Britain, CT 45 °C, temperature class 155 (F), used according to 155 (F)	<b>E21</b>															
With type test certificate according to BV (Bureau Veritas), France, CT 45 °C, temperature class 155 (F), used according to 155 (F)	<b>E31</b>															
With type test certificate according to DNV (Det Norske Veritas), Norway, CT 45 °C, temperature class 155 (F), used according to 155 (F)	<b>E51</b>															
<b>Acceptance/certification</b>																
Individual acceptance by marine classification society	<b>E10</b>															
	Details in plain text															
Type test with heat run for horizontal motors, with acceptance	<b>F83 <sup>2)</sup></b>															
Type test with heat run for vertical motors, with acceptance	Details in plain text <sup>2)</sup>															
<b>Self-ventilated energy-saving motors with high efficiency</b>																
<b>Basic marine version <sup>1)</sup></b>																
Without type test certificate according to ABS 50 °C/CCS 45 °C/RINA 45 °C, temperature class 155 (F) used according to 155 (F) (if acceptance test certificate 3.1 according to EN 10204 is required, this must be ordered with the additional order code <b>B02</b> )	<b>E00</b>															
With type test certificate according to GL (Germanischer Lloyd), Germany, CT 45 °C, temperature class 155 (F), used according to 155 (F)	<b>E11</b>															
With type test certificate according to LR (Lloyds Register), Great Britain, CT 45 °C, temperature class 155 (F), used according to 155 (F)	<b>E21</b>															
With type test certificate according to BV (Bureau Veritas), France, CT 45 °C, temperature class 155 (F), used according to 155 (F)	<b>E31</b>															
With type test certificate according to DNV (Det Norske Veritas), Norway, CT 45 °C, temperature class 155 (F), used according to 155 (F)	<b>E51</b>															
<b>Acceptance/certification</b>																
Individual acceptance by marine classification society	<b>E10 <sup>2)</sup></b>															
Type test with heat run for horizontal motors, with acceptance	<b>F83 <sup>2)</sup></b>															
Type test with heat run for vertical motors, with acceptance	Details in plain text <sup>2)</sup>															

For legend and footnotes, see Page 10/12.

# IEC Squirrel-Cage Motors

## Marine motors

### Special versions

Special versions	Additional identification code <b>-Z</b> with order code or plain text	Motor type frame size														
		56	63	71	80	90	100	112	132	160	180	200	225	250	280	315
<b>Self-ventilated energy-saving motors with high efficiency</b>																
<b>Basic marine version <sup>1)</sup></b>																
<b>1LG6 (cast-iron)</b>																
Without type test certificate according to ABS 50°C/CCS 45°C/RINA 45°C, temperature class 155 (F) used according to 155 (F) (if acceptance test certificate 3.1 according to EN 10204 is required, this must be ordered with the additional order code <b>B02</b> )	<b>E00</b>															
With type test certificate according to GL (Germanischer Lloyd), Germany, CT 45 °C, temperature class 155 (F), used according to 155 (F)	<b>E11</b>															
With type test certificate according to LR (Lloyds Register), Great Britain, CT 45 °C, temperature class 155 (F), used according to 155 (F)	<b>E21</b>															
With type test certificate according to BV (Bureau Veritas), France, CT 45 °C, temperature class 155 (F), used according to 155 (F)	<b>E31</b>															
With type test certificate according to DNV (Det Norske Veritas), Norway, CT 45 °C, temperature class 155 (F), used according to 155 (F)	<b>E51</b>															
<b>Acceptance/certification</b>																
Individual acceptance by marine classification society	<b>E10</b>															
Type test with heat run for horizontal motors, with acceptance	<b>F83 <sup>2)</sup></b>															
Type test with heat run for vertical motors, with acceptance	Details in plain text <sup>2)</sup>	O. R.	O. R.	O. R.	O. R.	O. R.	O. R.	O. R.	O. R.	O. R.	O. R.	O. R.	O. R.	O. R.	O. R.	O. R.

- ✓ With additional charge
- Not possible
- O. R. Possible on request

<sup>1)</sup> Motor for use in shipping for higher ambient temperature and/or used as 155 (F) according to 130 (B), order with details in plain text. The order codes for the basic marine version (**E00**, **E11**, **E21**, **E31**, **E51**) cannot be combined with each other. For motor series 1LA9 with increased output, the output is reduced by 4 % with order codes **E11**, **E31** and **E51** and by 8 % with order codes **E00** and **E21**.

<sup>2)</sup> Option or details in plain text only necessary for one motor when ordering several motors of the same type.

# IEC Squirrel-Cage Motors

## Marine motors

Special versions

### Type approved explosion-proof motors up to frame size 315 L in marine version

Special versions	Additional identification code <b>-Z</b> with order code or plain text	Motor type frame size														
		56	63	71	80	90	100	112	132	160	180	200	225	250	280	315
<b>Self-ventilated motors in Zone 1 with type of protection "e"</b>																
<b>1MA7 (aluminum)</b>																
<b>Basic marine version <sup>1)</sup></b>																
Without type test certificate according to ABS 50°C/CCS 45 °C/RINA 45 °C, temperature class 155 (F) used according to 155 (F) (if acceptance test certificate 3.1 according to EN 10204 is required, this must be ordered with the additional order code <b>B02</b> )	<b>E00</b>		✓	✓	✓	✓	✓	✓	✓	✓	✓	✓	✓	✓	✓	✓
With type test certificate according to GL (Germanischer Lloyd), Germany, CT 45 °C, temperature class 155 (F), used according to 155 (F)	<b>E11</b>		✓	✓	✓	✓	✓	✓	✓	✓	✓	✓	✓	✓	✓	✓
With type test certificate according to LR (Lloyds Register), Great Britain, CT 45 °C, temperature class 155 (F), used according to 155 (F)	<b>E21</b>		✓	✓	✓	✓	✓	✓	✓	✓	✓	✓	✓	✓	✓	✓
With type test certificate according to BV (Bureau Veritas), France, CT 45 °C, temperature class 155 (F), used according to 155 (F)	<b>E31</b>		✓	✓	✓	✓	✓	✓	✓	✓	✓	✓	✓	✓	✓	✓
With type test certificate according to DNV (Det Norske Veritas), Norway, CT 45 °C, temperature class 155 (F), used according to 155 (F)	<b>E51</b>		✓	✓	✓	✓	✓	✓	✓	✓	✓	✓	✓	✓	✓	✓
<b>Acceptance/certification</b>																
Individual acceptance by marine classification society	Details in plain text		O. R.	O. R.	O. R.	O. R.	O. R.	O. R.	O. R.	O. R.	O. R.	O. R.	O. R.	O. R.	O. R.	O. R.
Type test with heat run for horizontal motors, with acceptance	Details in plain text <sup>2)</sup>		O. R.	O. R.	O. R.	O. R.	O. R.	O. R.	O. R.	O. R.	O. R.	O. R.	O. R.	O. R.	O. R.	O. R.
Type test with heat run for vertical motors, with acceptance	Details in plain text <sup>2)</sup>		O. R.	O. R.	O. R.	O. R.	O. R.	O. R.	O. R.	O. R.	O. R.	O. R.	O. R.	O. R.	O. R.	O. R.
<b>1MA6 (cast-iron)</b>																
<b>Basic marine version <sup>1)</sup></b>																
Without type test certificate according to ABS 50°C/CCS 45 °C/RINA 45 °C, temperature class 155 (F) used according to 155 (F) (if acceptance test certificate 3.1 according to EN 10204 is required, this must be ordered with the additional order code <b>B02</b> )	<b>E00</b>		✓	✓	✓	✓	✓	✓	✓	✓	✓	✓	✓	✓	✓	✓
With type test certificate according to GL (Germanischer Lloyd), Germany, CT 45 °C, temperature class 155 (F), used according to 155 (F)	<b>E11</b>		✓	✓	✓	✓	✓	✓	✓	✓	✓	✓	✓	✓	✓	✓
With type test certificate according to LR (Lloyds Register), Great Britain, CT 45 °C, temperature class 155 (F), used according to 155 (F)	<b>E21</b>		✓	✓	✓	✓	✓	✓	✓	✓	✓	✓	✓	✓	✓	✓
With type test certificate according to BV (Bureau Veritas), France, CT 45 °C, temperature class 155 (F), used according to 155 (F)	<b>E31</b>		✓	✓	✓	✓	✓	✓	✓	✓	✓	✓	✓	✓	✓	✓
With type test certificate according to DNV (Det Norske Veritas), Norway, CT 45 °C, temperature class 155 (F), used according to 155 (F)	<b>E51</b>		✓	✓	✓	✓	✓	✓	✓	✓	✓	✓	✓	✓	✓	✓
<b>Acceptance/certification</b>																
Individual acceptance by marine classification society	Details in plain text		O. R.	O. R.	O. R.	O. R.	O. R.	O. R.	O. R.	O. R.	O. R.	O. R.	O. R.	O. R.	O. R.	O. R.
Type test with heat run for horizontal motors, with acceptance	Details in plain text <sup>2)</sup>		O. R.	O. R.	O. R.	O. R.	O. R.	O. R.	O. R.	O. R.	O. R.	O. R.	O. R.	O. R.	O. R.	O. R.
Type test with heat run for vertical motors, with acceptance	Details in plain text <sup>2)</sup>		O. R.	O. R.	O. R.	O. R.	O. R.	O. R.	O. R.	O. R.	O. R.	O. R.	O. R.	O. R.	O. R.	O. R.

10

For legend and footnotes, see Page 10/14.

# IEC Squirrel-Cage Motors

## Marine motors

### Special versions

Special versions	Additional identification code <b>-Z</b> with order code or plain text	Motor type frame size													
		56	63	71	80	90	100	112	132	160	180	200	225	250	280
<b>Self-ventilated motors in Zone 1 with type of protection “de”</b>															
<b>Basic marine version <sup>1)</sup></b>															
		<b>1MJ6 (cast-iron)</b>							<b>1MJ7 (cast-iron)</b>						
Without type test certificate according to ABS 50 °C/CCS 45 °C/RINA 45 °C, temperature class 155 (F) used according to 155 (F) (if acceptance test certificate 3.1 according to EN 10204 is required, this must be ordered with the additional order code <b>B02</b> )	<b>E00</b>		✓	✓	✓	✓	✓	✓	✓	✓	✓	✓	✓	✓	✓
With type test certificate according to GL (Germanischer Lloyd), Germany, CT 45 °C, temperature class 155 (F), used according to 155 (F)	<b>E11</b>		✓	✓	✓	✓	✓	✓	✓	✓	✓	✓	✓	✓	✓
With type test certificate according to LR (Lloyds Register), Great Britain, CT 45 °C, temperature class 155 (F), used according to 155 (F)	<b>E21</b>		✓	✓	✓	✓	✓	✓	✓	✓	✓	✓	✓	✓	✓
With type test certificate according to BV (Bureau Veritas), France, CT 45 °C, temperature class 155 (F), used according to 155 (F)	<b>E31</b>		✓	✓	✓	✓	✓	✓	✓	✓	✓	✓	✓	✓	✓
With type test certificate according to DNV (Det Norske Veritas), Norway, CT 45 °C, temperature class 155 (F), used according to 155 (F)	<b>E51</b>		✓	✓	✓	✓	✓	✓	✓	✓	✓	✓	✓	✓	✓
<b>Acceptance/certification</b>															
Individual acceptance by marine classification society	Details in plain text		O. R.	O. R.	O. R.	O. R.	O. R.	O. R.	O. R.	O. R.	O. R.	O. R.	O. R.	O. R.	O. R.
Type test with heat run for horizontal motors, with acceptance	Details in plain text <sup>2)</sup>		O. R.	O. R.	O. R.	O. R.	O. R.	O. R.	O. R.	O. R.	O. R.	O. R.	O. R.	O. R.	O. R.
Type test with heat run for vertical motors, with acceptance	Details in plain text <sup>2)</sup>		O. R.	O. R.	O. R.	O. R.	O. R.	O. R.	O. R.	O. R.	O. R.	O. R.	O. R.	O. R.	O. R.

✓ With additional charge  
O. R. Possible on request

<sup>1)</sup> Motor for use in shipping for higher ambient temperature and/or used as 155 (F) according to 130 (B), order with details in plain text. In some cases motor series 1MA is supplied with reduced output, but is designed for the maximum possible and certified output. For motor series 1MJ output is reduced by 4 % for order codes **E11**, **E21**, **E31** and **E51** and by 8 % for order code **E00**. The order codes for the basic marine version (**E00**, **E11**, **E21**, **E31**, **E51**) cannot be combined with each other.

<sup>2)</sup> Option or details in plain text only necessary for one motor when ordering several motors of the same type.



# IEC Squirrel-Cage Motors

## Marine motors

### Special versions

Special versions	Additional identification code <b>-Z</b> with order code or plain text	Motor type frame size														
		56	63	71	80	90	100	112	132	160	180	200	225	250	280	315
<b>Self-ventilated motors in Zones 2, 21 and 22 with type of protection "n" or protection against dust explosions</b>																
<b>1LA7 (aluminum) <sup>1)</sup></b>																
<b>1LA5 (aluminum) <sup>2)</sup></b>																
<b>Basic marine version <sup>3)</sup></b>																
Without type test certificate according to ABS 50°C/CCS 45 °C/RINA 45 °C, temperature class 155 (F) used according to 155 (F) (if acceptance test certificate 3.1 according to EN 10204 is required, this must be ordered with the additional order code <b>B02</b> )	<b>E00</b>	✓	✓	✓	✓	✓	✓	✓	✓	✓	✓	✓	✓	✓	✓	✓
With type test certificate according to GL (Germanischer Lloyd), Germany, CT 45 °C, temperature class 155 (F), used according to 155 (F)	<b>E11</b>	✓	✓	✓	✓	✓	✓	✓	✓	✓	✓	✓	✓	✓	✓	✓
With type test certificate according to LR (Lloyds Register), Great Britain, CT 45 °C, temperature class 155 (F), used according to 155 (F)	<b>E21</b>	✓	✓	✓	✓	✓	✓	✓	✓	✓	✓	✓	✓	✓	✓	✓
With type test certificate according to BV (Bureau Veritas), France, CT 45 °C, temperature class 155 (F), used according to 155 (F)	<b>E31</b>	✓	✓	✓	✓	✓	✓	✓	✓	✓	✓	✓	✓	✓	✓	✓
With type test certificate according to DNV (Det Norske Veritas), Norway, CT 45 °C, temperature class 155 (F), used according to 155 (F)	<b>E51</b>	✓	✓	✓	✓	✓	✓	✓	✓	✓	✓	✓	✓	✓	✓	✓
<b>Acceptance/certification</b>																
Individual acceptance by marine classification society	<b>E10</b>	✓	✓	✓	✓	✓	✓	✓	✓	✓	✓	✓	✓	✓	✓	✓
Type test with heat run for horizontal motors, with acceptance	<b>F83 <sup>4)</sup></b>	✓	✓	✓	✓	✓	✓	✓	✓	✓	✓	✓	✓	✓	✓	✓
Type test with heat run for vertical motors, with acceptance	Details in plain text <sup>4)</sup>	O. R.	O. R.	O. R.	O. R.	O. R.	O. R.	O. R.	O. R.	O. R.	O. R.	O. R.	O. R.	O. R.	O. R.	O. R.
<b>1LA9 (aluminum) <sup>5)</sup></b>																
<b>Basic marine version <sup>3)</sup></b>																
Without type test certificate according to ABS 50°C/CCS 45 °C/RINA 45 °C, temperature class 155 (F) used according to 155 (F) (if acceptance test certificate 3.1 according to EN 10204 is required, this must be ordered with the additional order code <b>B02</b> )	<b>E00</b>	✓	✓	✓	✓	✓	✓	✓	✓	✓	✓	✓	✓	✓	✓	✓
With type test certificate according to GL (Germanischer Lloyd), Germany, CT 45 °C, temperature class 155 (F), used according to 155 (F)	<b>E11</b>	✓	✓	✓	✓	✓	✓	✓	✓	✓	✓	✓	✓	✓	✓	✓
With type test certificate according to LR (Lloyds Register), Great Britain, CT 45 °C, temperature class 155 (F), used according to 155 (F)	<b>E21</b>	✓	✓	✓	✓	✓	✓	✓	✓	✓	✓	✓	✓	✓	✓	✓
With type test certificate according to BV (Bureau Veritas), France, CT 45 °C, temperature class 155 (F), used according to 155 (F)	<b>E31</b>	✓	✓	✓	✓	✓	✓	✓	✓	✓	✓	✓	✓	✓	✓	✓
With type test certificate according to DNV (Det Norske Veritas), Norway, CT 45 °C, temperature class 155 (F), used according to 155 (F)	<b>E51</b>	✓	✓	✓	✓	✓	✓	✓	✓	✓	✓	✓	✓	✓	✓	✓
<b>Acceptance/certification</b>																
Individual acceptance by marine classification society	<b>E10</b>	✓	✓	✓	✓	✓	✓	✓	✓	✓	✓	✓	✓	✓	✓	✓
Type test with heat run for horizontal motors, with acceptance	<b>F83 <sup>4)</sup></b>	✓	✓	✓	✓	✓	✓	✓	✓	✓	✓	✓	✓	✓	✓	✓
Type test with heat run for vertical motors, with acceptance	Details in plain text <sup>4)</sup>	O. R.	O. R.	O. R.	O. R.	O. R.	O. R.	O. R.	O. R.	O. R.	O. R.	O. R.	O. R.	O. R.	O. R.	O. R.

For legend and footnotes, see Page 10/16.

# IEC Squirrel-Cage Motors

## Marine motors

### Special versions

Special versions	Additional identification code <b>-Z</b> with order code or plain text	Motor type frame size														
		56	63	71	80	90	100	112	132	160	180	200	225	250	280	315
<b>Self-ventilated motors in Zones 2, 21 and 22 with type of protection "n" or protection against dust explosions</b>																
<b>Basic marine version <sup>3)</sup></b>																
Without type test certificate according to ABS 50 °C/CCS 45 °C/RINA 45 °C, temperature class 155 (F) used according to 155 (F) (if acceptance test certificate 3.1 according to EN 10204 is required, this must be ordered with the additional order code <b>B02</b> )	<b>E00</b>															
With type test certificate according to GL (Germanischer Lloyd), Germany, CT 45 °C, temperature class 155 (F), used according to 155 (F)	<b>E11</b>															
With type test certificate according to LR (Lloyds Register), Great Britain, CT 45 °C, temperature class 155 (F), used according to 155 (F)	<b>E21</b>															
With type test certificate according to BV (Bureau Veritas), France, CT 45 °C, temperature class 155 (F), used according to 155 (F)	<b>E31</b>															
With type test certificate according to DNV (Det Norske Veritas), Norway, CT 45 °C, temperature class 155 (F), used according to 155 (F)	<b>E51</b>															
<b>Acceptance/certification</b>																
Individual acceptance by marine classification society	<b>E10</b>															
	Details in plain text															
Type test with heat run for horizontal motors, with acceptance	<b>F83 <sup>4)</sup></b>															
Type test with heat run for vertical motors, with acceptance	Details in plain text <sup>4)</sup>															

- ✓ With additional charge  
 – Not possible  
 O. R. Possible on request

<sup>1)</sup> Zone 2 for 1LA7 motors not possible in frame size 56.  
<sup>2)</sup> Zone 2 for 1LA5 motors not possible, for Zone 2 use 1LG4 motors instead of 1LA5 motors.  
<sup>3)</sup> Motor for use in shipping for higher ambient temperature and/or used as 155 (F) according to 130 (B), order with details in plain text. The output of motors is reduced by 4 % for order codes **E11**, **E21**, **E31** and **E51** and by 8 % for order code **E00**. The order codes for the basic marine version (**E00**, **E11**, **E21**, **E31**, **E51**) cannot be combined with each other.

<sup>4)</sup> Option or details in plain text only necessary for one motor when ordering several motors of the same type.  
<sup>5)</sup> Zone 2 not possible for 1LA9 motors in frame sizes 56, 180 and 200.  
<sup>6)</sup> Zone 21 not possible for 1LA6 motors.

# IEC Squirrel-Cage Motors

## Marine motors

### Special versions

#### Type approved fan motors in marine version

Special versions	Additional identification code -Z with order code or plain text	Motor type frame size												
		56	63	71	80	90	100	112	132	160	180	200	225	250

#### Self-ventilated motors in pole-changing version

		1LA7 (aluminum)						1LA5 (aluminum)	
<b>Basic marine version <sup>1)</sup></b>									
Without type test certificate according to ABS 50 °C/CCS 45 °C/RINA 45 °C, temperature class 155 (F) used according to 155 (F) (if acceptance test certificate 3.1 according to EN 10204 is required, this must be ordered with the additional order code <b>B02</b> )	<b>E00</b>	✓	✓	✓	✓	✓	✓	✓	✓
With type test certificate according to GL (Germanischer Lloyd), Germany, CT 45 °C, temperature class 155 (F), used according to 155 (F)	<b>E11</b>	✓	✓	✓	✓	✓	✓	✓	✓
With type test certificate according to LR (Lloyds Register), Great Britain, CT 45 °C, temperature class 155 (F), used according to 155 (F)	<b>E21</b>	✓	✓	✓	✓	✓	✓	✓	✓
With type test certificate according to BV (Bureau Veritas), France, CT 45 °C, temperature class 155 (F), used according to 155 (F)	<b>E31</b>	✓	✓	✓	✓	✓	✓	✓	✓
With type test certificate according to DNV (Det Norske Veritas), Norway, CT 45 °C, temperature class 155 (F), used according to 155 (F)	<b>E51</b>	✓	✓	✓	✓	✓	✓	✓	✓
<b>Acceptance/certification</b>									
Individual acceptance by marine classification society	<b>E10</b>	✓	✓	✓	✓	✓	✓	✓	✓
Type test with heat run for horizontal motors, with acceptance	<b>F83 <sup>2)</sup></b>	✓	✓	✓	✓	✓	✓	✓	✓
Type test with heat run for vertical motors, with acceptance	Details in plain text <sup>2)</sup>	O. R.	O. R.	O. R.	O. R.	O. R.	O. R.	O. R.	O. R.
<b>1LG4 (cast-iron)</b>									
<b>Basic marine version <sup>1)</sup></b>									
Without type test certificate according to ABS 50 °C/CCS 45 °C/RINA 45 °C, temperature class 155 (F) used according to 155 (F) (if acceptance test certificate 3.1 according to EN 10204 is required, this must be ordered with the additional order code <b>B02</b> )	<b>E00</b>	✓	✓	✓	✓	✓	✓	✓	✓
With type test certificate according to GL (Germanischer Lloyd), Germany, CT 45 °C, temperature class 155 (F), used according to 155 (F)	<b>E11</b>	✓	✓	✓	✓	✓	✓	✓	✓
With type test certificate according to LR (Lloyds Register), Great Britain, CT 45 °C, temperature class 155 (F), used according to 155 (F)	<b>E21</b>	✓	✓	✓	✓	✓	✓	✓	✓
With type test certificate according to BV (Bureau Veritas), France, CT 45 °C, temperature class 155 (F), used according to 155 (F)	<b>E31</b>	✓	✓	✓	✓	✓	✓	✓	✓
With type test certificate according to DNV (Det Norske Veritas), Norway, CT 45 °C, temperature class 155 (F), used according to 155 (F)	<b>E51</b>	✓	✓	✓	✓	✓	✓	✓	✓
<b>Acceptance/certification</b>									
Individual acceptance by marine classification society	<b>E10</b>	✓	✓	✓	✓	✓	✓	✓	✓
Type test with heat run for horizontal motors, with acceptance	<b>F83 <sup>2)</sup></b>	✓	✓	✓	✓	✓	✓	✓	✓
Type test with heat run for vertical motors, with acceptance	Details in plain text <sup>2)</sup>	O. R.	O. R.	O. R.	O. R.	O. R.	O. R.	O. R.	O. R.

# IEC Squirrel-Cage Motors

## Marine motors

### Special versions

Special versions	Additional identification code -Z with order code or plain text	Motor type frame size														
		56	63	71	80	90	100	112	132	160	180	200	225	250	280	315
<b>Forced-air cooled motors without external fan and fan cover</b>																
		<b>1PP7 (aluminum)</b>										<b>1PP5 (aluminum)</b>				
<b>Basic marine version <sup>1)</sup></b>																
Without type test certificate according to ABS 50 °C/CCS 45 °C/RINA 45 °C, temperature class 155 (F) used according to 155 (F) (if acceptance test certificate 3.1 according to EN 10204 is required, this must be ordered with the additional order code <b>B02</b> )	<b>E00</b>	✓	✓	✓	✓	✓	✓	✓	✓	✓	✓	✓	✓	✓	✓	✓
With type test certificate according to GL (Germanischer Lloyd), Germany, CT 45 °C, temperature class 155 (F), used according to 155 (F)	<b>E11</b>	✓	✓	✓	✓	✓	✓	✓	✓	✓	✓	✓	✓	✓	✓	✓
With type test certificate according to LR (Lloyds Register), Great Britain, CT 45 °C, temperature class 155 (F), used according to 155 (F)	<b>E21</b>	✓	✓	✓	✓	✓	✓	✓	✓	✓	✓	✓	✓	✓	✓	✓
With type test certificate according to BV (Bureau Veritas), France, CT 45 °C, temperature class 155 (F), used according to 155 (F)	<b>E31</b>	✓	✓	✓	✓	✓	✓	✓	✓	✓	✓	✓	✓	✓	✓	✓
With type test certificate according to DNV (Det Norske Veritas), Norway, CT 45 °C, temperature class 155 (F), used according to 155 (F)	<b>E51</b>	✓	✓	✓	✓	✓	✓	✓	✓	✓	✓	✓	✓	✓	✓	✓
<b>Acceptance/certification</b>																
Individual acceptance by marine classification society	<b>E10</b>	✓	✓	✓	✓	✓	✓	✓	✓	✓	✓	✓	✓	✓	✓	✓
Type test with heat run for horizontal motors, with acceptance	<b>F83 <sup>2)</sup></b>	✓	✓	✓	✓	✓	✓	✓	✓	✓	✓	✓	✓	✓	✓	✓
Type test with heat run for vertical motors, with acceptance	Details in plain text <sup>2)</sup>	O. R.	O. R.	O. R.	O. R.	O. R.	O. R.	O. R.	O. R.	O. R.	O. R.	O. R.	O. R.	O. R.	O. R.	O. R.
		<b>1PP4 (cast-iron)</b>														
<b>Basic marine version <sup>1)</sup></b>																
Without type test certificate according to ABS 50 °C/CCS 45 °C/RINA 45 °C, temperature class 155 (F) used according to 155 (F) (if acceptance test certificate 3.1 according to EN 10204 is required, this must be ordered with the additional order code <b>B02</b> )	<b>E00</b>	✓	✓	✓	✓	✓	✓	✓	✓	✓	✓	✓	✓	✓	✓	✓
With type test certificate according to GL (Germanischer Lloyd), Germany, CT 45 °C, temperature class 155 (F), used according to 155 (F)	<b>E11</b>	✓	✓	✓	✓	✓	✓	✓	✓	✓	✓	✓	✓	✓	✓	✓
With type test certificate according to LR (Lloyds Register), Great Britain, CT 45 °C, temperature class 155 (F), used according to 155 (F)	<b>E21</b>	✓	✓	✓	✓	✓	✓	✓	✓	✓	✓	✓	✓	✓	✓	✓
With type test certificate according to BV (Bureau Veritas), France, CT 45 °C, temperature class 155 (F), used according to 155 (F)	<b>E31</b>	✓	✓	✓	✓	✓	✓	✓	✓	✓	✓	✓	✓	✓	✓	✓
With type test certificate according to DNV (Det Norske Veritas), Norway, CT 45 °C, temperature class 155 (F), used according to 155 (F)	<b>E51</b>	✓	✓	✓	✓	✓	✓	✓	✓	✓	✓	✓	✓	✓	✓	✓
<b>Acceptance/certification</b>																
Individual acceptance by marine classification society	<b>E10</b>	✓	✓	✓	✓	✓	✓	✓	✓	✓	✓	✓	✓	✓	✓	✓
Type test with heat run for horizontal motors, with acceptance	<b>F83 <sup>2)</sup></b>	✓	✓	✓	✓	✓	✓	✓	✓	✓	✓	✓	✓	✓	✓	✓
Type test with heat run for vertical motors, with acceptance	Details in plain text <sup>2)</sup>	O. R.	O. R.	O. R.	O. R.	O. R.	O. R.	O. R.	O. R.	O. R.	O. R.	O. R.	O. R.	O. R.	O. R.	O. R.

✓ With additional charge  
 – Not possible  
 O. R. Possible on request

<sup>1)</sup> Motor for use in shipping for higher ambient temperature and/or used as 155 (F) according to 130 (B), order with details in plain text. The order codes for the basic marine version (**E00**, **E11**, **E21**, **E31**, **E51**) cannot be combined with each other.

<sup>2)</sup> Option or details in plain text only necessary for one motor when ordering several motors of the same type.

# IEC Squirrel-Cage Motors

## Marine motors

### Special versions

#### Standard motors up to frame size 315 L in marine version (individual acceptance required)

Special versions	Additional identification code <b>-Z</b> with order code or plain text	Motor type frame size														
		56	63	71	80	90	100	112	132	160	180	200	225	250	280	315
<b>Self-cooled motors without external fan</b>																
<b>Basic marine version <sup>1) 2)</sup></b>																
Without type test certificate according to ABS 50 °C/CCS 45 °C/RINA 45 °C, temperature class 155 (F) used according to 155 (F) (if acceptance test certificate 3.1 according to EN 10204 is required, this must be ordered with the additional order code <b>B02</b> )	<b>E00</b>			✓	✓	✓	✓	✓	✓	✓	✓	✓	✓	✓	✓	✓
<b>Acceptance/certification</b>																
Individual acceptance by marine classification society	<b>E10</b>			✓	✓	✓	✓	✓	✓	✓	✓	✓	✓	✓	✓	✓
Type test with heat run for horizontal motors, with acceptance	<b>F83 <sup>3)</sup></b>			✓	✓	✓	✓	✓	✓	✓	✓	✓	✓	✓	✓	✓
Type test with heat run for vertical motors, with acceptance	Details in plain text <sup>3)</sup>			O. R.	O. R.	O. R.	O. R.	O. R.	O. R.	O. R.	O. R.	O. R.	O. R.	O. R.	O. R.	O. R.
<b>Basic marine version <sup>1) 2)</sup></b>																
Without type test certificate according to ABS 50 °C/CCS 45 °C/RINA 45 °C, temperature class 155 (F) used according to 155 (F) (if acceptance test certificate 3.1 according to EN 10204 is required, this must be ordered with the additional order code <b>B02</b> )	<b>E00</b>											✓	✓	✓	✓	✓
<b>Acceptance/certification</b>																
Individual acceptance by marine classification society	<b>E10</b>											✓	✓	✓	✓	✓
Type test with heat run for horizontal motors, with acceptance	<b>F83 <sup>3)</sup></b>											✓	✓	✓	✓	✓
Type test with heat run for vertical motors, with acceptance	Details in plain text <sup>3)</sup>											O. R.	O. R.	O. R.	O. R.	O. R.

✓ With additional charge  
O. R. Possible on request

<sup>1)</sup> Motor for use in shipping for higher ambient temperature and/or used as 155 (F) according to 130 (B), order with details in plain text. The output of motors is reduced by 8 % for order code **E00**. The order codes for the basic marine version (**E00**, **E11**, **E21**, **E31**, **E51**) cannot be combined with each other.

<sup>2)</sup> Certification is possible on request according to the marine classification authorities GL, LR, BV and DNV.

<sup>3)</sup> Option or details in plain text only necessary for one motor when ordering several motors of the same type.

# IEC Squirrel-Cage Motors

## Marine motors

### Special versions

#### Smoke-extraction motors as marine version (individual acceptance required)

Special versions	Additional identification code <b>-Z</b> with order code or plain text	Motor type frame size															
		56	63	71	80	90	100	112	132	160	180	200	225	250	280	315	
<b>Self-ventilated motors</b>																	
<b>Basic marine version <sup>1)</sup></b>																	
		<b>1LA7 (aluminum)</b>						<b>1LA5 (aluminum)</b>									
Without type test certificate according to ABS 50 °C/CCS 45 °C/RINA 45 °C, temperature class 155 (F) used according to 155 (F) (if acceptance test certificate 3.1 according to EN 10204 is required, this must be ordered with the additional order code <b>B02</b> )	<b>E00</b>						✓	✓	✓	✓	✓	✓	✓	✓	✓	✓	
With type test certificate according to GL (Germanischer Lloyd), Germany, CT 45 °C, temperature class 155 (F), used according to 155 (F)	<b>E11</b>						✓	✓	✓	✓	✓	✓	✓	✓	✓	✓	
With type test certificate according to LR (Lloyds Register), Great Britain, CT 45 °C, temperature class 155 (F), used according to 155 (F)	<b>E21</b>						✓	✓	✓	✓	✓	✓	✓	✓	✓	✓	
With type test certificate according to BV (Bureau Veritas), France, CT 45 °C, temperature class 155 (F), used according to 155 (F)	<b>E31</b>						✓	✓	✓	✓	✓	✓	✓	✓	✓	✓	
With type test certificate according to DNV (Det Norske Veritas), Norway, CT 45 °C, temperature class 155 (F), used according to 155 (F)	<b>E51</b>						✓	✓	✓	✓	✓	✓	✓	✓	✓	✓	
<b>Acceptance/certification</b>																	
Individual acceptance by marine classification society	<b>E10</b>						✓	✓	✓	✓	✓	✓	✓	✓	✓	✓	
Type test with heat run for horizontal motors, with acceptance	<b>F83 <sup>2)</sup></b>						✓	✓	✓	✓	✓	✓	✓	✓	✓	✓	
Type test with heat run for vertical motors, with acceptance	Details in plain text <sup>2)</sup>						O. R.	O. R.	O. R.	O. R.	O. R.	O. R.	O. R.	O. R.	O. R.	O. R.	
<b>Basic marine version <sup>1)</sup></b>																	
		<b>1LA6 (cast-iron)</b>						<b>1LG6 (cast-iron)</b>									
Without type test certificate according to ABS 50 °C/CCS 45 °C/RINA 45 °C, temperature class 155 (F) used according to 155 (F) (if acceptance test certificate 3.1 according to EN 10204 is required, this must be ordered with the additional order code <b>B02</b> )	<b>E00</b>						✓	✓	✓	✓	✓	✓	✓	✓	✓	✓	
With type test certificate according to GL (Germanischer Lloyd), Germany, CT 45 °C, temperature class 155 (F), used according to 155 (F)	<b>E11</b>						✓	✓	✓	✓	✓	✓	✓	✓	✓	✓	
With type test certificate according to LR (Lloyds Register), Great Britain, CT 45 °C, temperature class 155 (F), used according to 155 (F)	<b>E21</b>						✓	✓	✓	✓	✓	✓	✓	✓	✓	✓	
With type test certificate according to BV (Bureau Veritas), France, CT 45 °C, temperature class 155 (F), used according to 155 (F)	<b>E31</b>						✓	✓	✓	✓	✓	✓	✓	✓	✓	✓	
With type test certificate according to DNV (Det Norske Veritas), Norway, CT 45 °C, temperature class 155 (F), used according to 155 (F)	<b>E51</b>						✓	✓	✓	✓	✓	✓	✓	✓	✓	✓	
<b>Acceptance/certification</b>																	
Individual acceptance by marine classification society	<b>E10</b>						✓	✓	✓	✓	✓	✓	✓	✓	✓	✓	
Type test with heat run for horizontal motors, with acceptance	<b>F83 <sup>2)</sup></b>						✓	✓	✓	✓	✓	✓	✓	✓	✓	✓	
Type test with heat run for vertical motors, with acceptance	Details in plain text <sup>2)</sup>						O. R.	O. R.	O. R.	O. R.	O. R.	O. R.	O. R.	O. R.	O. R.	O. R.	

For legend and footnotes, see Page 10/22.

# IEC Squirrel-Cage Motors

## Marine motors

### Special versions

Special versions	Additional identification code <b>-Z</b> with order code or plain text	Motor type frame size														
		56	63	71	80	90	100	112	132	160	180	200	225	250	280	315
<b>Forced-air ventilated motors</b>																
<b>Basic marine version <sup>1)</sup></b>																
Without type test certificate according to ABS 50°C/CCS 45 °C/RINA 45 °C, temperature class 155 (F) used according to 155 (F) (if acceptance test certificate 3.1 according to EN 10204 is required, this must be ordered with the additional order code <b>B02</b> )	<b>E00</b>					✓	✓	✓	✓	✓	✓	✓	✓	✓	✓	✓
With type test certificate according to GL (Germanischer Lloyd), Germany, CT 45 °C, temperature class 155 (F), used according to 155 (F)	<b>E11</b>					✓	✓	✓	✓	✓	✓	✓	✓	✓	✓	✓
With type test certificate according to LR (Lloyds Register), Great Britain, CT 45 °C, temperature class 155 (F), used according to 155 (F)	<b>E21</b>					✓	✓	✓	✓	✓	✓	✓	✓	✓	✓	✓
With type test certificate according to BV (Bureau Veritas), France, CT 45 °C, temperature class 155 (F), used according to 155 (F)	<b>E31</b>					✓	✓	✓	✓	✓	✓	✓	✓	✓	✓	✓
With type test certificate according to DNV (Det Norske Veritas), Norway, CT 45 °C, temperature class 155 (F), used according to 155 (F)	<b>E51</b>					✓	✓	✓	✓	✓	✓	✓	✓	✓	✓	✓
<b>Acceptance/certification</b>																
Individual acceptance by marine classification society	<b>E10</b>					✓	✓	✓	✓	✓	✓	✓	✓	✓	✓	✓
Type test with heat run for horizontal motors, with acceptance	<b>F83 <sup>2)</sup></b>					✓	✓	✓	✓	✓	✓	✓	✓	✓	✓	✓
Type test with heat run for vertical motors, with acceptance	Details in plain text <sup>2)</sup>					O. R.	O. R.	O. R.	O. R.	O. R.	O. R.	O. R.	O. R.	O. R.	O. R.	O. R.

# IEC Squirrel-Cage Motors

## Marine motors

### Special versions

Special versions	Additional identification code <b>-Z</b> with order code or plain text	Motor type frame size														
		56	63	71	80	90	100	112	132	160	180	200	225	250	280	315
<b>Basic marine version <sup>1)</sup></b>		<b>1PP6 (cast-iron)</b>														
Without type test certificate according to ABS 50°C/CCS 45 °C/RINA 45 °C, temperature class 155 (F) used according to 155 (F) (if acceptance test certificate 3.1 according to EN 10204 is required, this must be ordered with the additional order code <b>B02</b> )	<b>E00</b>						✓	✓	✓	✓	✓	✓	✓	✓	✓	✓
With type test certificate according to GL (Germanischer Lloyd), Germany, CT 45 °C, temperature class 155 (F), used according to 155 (F)	<b>E11</b>						✓	✓	✓	✓	✓	✓	✓	✓	✓	✓
With type test certificate according to LR (Lloyds Register), Great Britain, CT 45 °C, temperature class 155 (F), used according to 155 (F)	<b>E21</b>						✓	✓	✓	✓	✓	✓	✓	✓	✓	✓
With type test certificate according to BV (Bureau Veritas), France, CT 45 °C, temperature class 155 (F), used according to 155 (F)	<b>E31</b>						✓	✓	✓	✓	✓	✓	✓	✓	✓	✓
With type test certificate according to DNV (Det Norske Veritas), Norway, CT 45 °C, temperature class 155 (F), used according to 155 (F)	<b>E51</b>						✓	✓	✓	✓	✓	✓	✓	✓	✓	✓
<b>Acceptance/certification</b>																
Individual acceptance by marine classification society	<b>E10</b>						✓	✓	✓	✓	✓	✓	✓	✓	✓	✓
Type test with heat run for horizontal motors, with acceptance	<b>F83 <sup>2)</sup></b>						✓	✓	✓	✓	✓	✓	✓	✓	✓	✓
Type test with heat run for vertical motors, with acceptance	Details in plain text <sup>2)</sup>						O. R.	O. R.	O. R.	O. R.	O. R.	O. R.	O. R.	O. R.	O. R.	O. R.

- ✓ With additional charge
- Not possible
- O. R. Possible on request

<sup>1)</sup> The order codes for the basic marine version (**E00, E11, E21, E31, E51**) cannot be combined with each other.

<sup>2)</sup> Option or details in plain text only necessary for one motor when ordering several motors of the same type.



# IEC Squirrel-Cage Motors

## Marine motors

### Special versions

#### Non-standard motors frame size 315 and above in marine version (individual acceptance required)

Special versions	Additional identification code <b>-Z</b> with order code or plain text	Motor type frame size			
		315	355	400	450
<b>Self-ventilated motors for mains-fed and converter-fed operation</b>					
		<b>1LA8 (cast-iron)</b>			
<b>Basic marine version <sup>1)</sup></b>					
Without type test certificate according to GL (Germanischer Lloyd), Germany, CT 45 °C, temperature class 155 (F) used according to 155 (F)	<b>E11</b>	✓	✓	✓	✓
Without type test certificate according to LR (Lloyds Register), Great Britain, CT 45 °C, temperature class 155 (F) used according to 155 (F)	<b>E21</b>	✓	✓	✓	✓
Without type test certificate according to BV (Bureau Veritas), France, CT 45 °C, temperature class 155 (F) used according to 155 (F)	<b>E31</b>	✓	✓	✓	✓
Without type test certificate according to DNV (Det Norske Veritas), Norway, CT 45 °C, temperature class 155 (F) used according to 155 (F)	<b>E51</b>	✓	✓	✓	✓
Without type test certificate according to ABS (American Bureau of Shipping), USA, CT 50 °C, temperature class 155 (F), used according to 155 (F)	<b>E61</b>	✓	✓	✓	✓
Without type test certificate according to CCS (Chinese Classification Society), China, CT 45 °C, temperature class 155 (F), used according to 155 (F)	<b>E71</b>	✓	✓	✓	✓
Motor for use in shipping, higher ambient temperature and/or used as temperature class 155 (F) according to 130 (B)	<b>E80 + plain text details</b>	✓	✓	✓	✓
<b>Acceptance/certification</b>					
Individual acceptance by marine classification society	<b>E10</b>	✓	✓	✓	✓
Individual acceptance by marine classification society with supervision of construction and acceptance test certificate 3.2 according to EN 10204	<b>E09</b>	✓	✓	✓	✓
Type test with heat run for horizontal motors, with acceptance	<b>F83 <sup>2)</sup></b>	✓	✓	✓	✓
Type test with heat run for vertical motors, with acceptance	<b>F93 <sup>2)</sup></b>	✓	✓	✓	✓
<b>Forced-air cooled motors with externally mounted fan for converter-fed operation</b>					
		<b>1PQ8 (cast-iron)</b>			
<b>Basic marine version <sup>1)</sup></b>					
Without type test certificate according to GL (Germanischer Lloyd), Germany, CT 45 °C, temperature class 155 (F) used according to 155 (F)	<b>E11</b>	✓	✓	✓	✓
Without type test certificate according to LR (Lloyds Register), Great Britain, CT 45 °C, temperature class 155 (F) used according to 155 (F)	<b>E21</b>	✓	✓	✓	✓
Without type test certificate according to BV (Bureau Veritas), France, CT 45 °C, temperature class 155 (F) used according to 155 (F)	<b>E31</b>	✓	✓	✓	✓
Without type test certificate according to DNV (Det Norske Veritas), Norway, CT 45 °C, temperature class 155 (F) used according to 155 (F)	<b>E51</b>	✓	✓	✓	✓
Without type test certificate according to ABS (American Bureau of Shipping), USA, CT 50 °C, temperature class 155 (F), used according to 155 (F)	<b>E61</b>	✓	✓	✓	✓
Without type test certificate according to CCS (Chinese Classification Society), China, CT 45 °C, temperature class 155 (F), used according to 155 (F)	<b>E71</b>	✓	✓	✓	✓
Motor for use in shipping, higher ambient temperature and/or used as temperature class 155 (F) according to 130 (B)	<b>E80 + plain text details</b>	✓	✓	✓	✓
<b>Acceptance/certification</b>					
Individual acceptance by marine classification society	<b>E10</b>	✓	✓	✓	✓
Individual acceptance by marine classification society with supervision of construction and acceptance test certificate 3.2 according to EN 10204	<b>E09</b>	✓	✓	✓	✓
Type test with heat run for horizontal motors, with acceptance	<b>F83 <sup>2)</sup></b>	✓	✓	✓	✓
Type test with heat run for vertical motors, with acceptance	<b>F93 <sup>2)</sup></b>	✓	✓	✓	✓

# IEC Squirrel-Cage Motors

## Marine motors

### Special versions

Special versions	Additional identification code <b>-Z</b> with order code or plain text	Motor type frame size			
		315	355	400	450
<b>Self-ventilated motors with through ventilation for mains-fed and converter-fed operation</b>					
		<b>1LL8 (cast-iron)</b>			
<b>Basic marine version <sup>1)</sup></b>					
Without type test certificate according to GL (Germanischer Lloyd), Germany, CT 45 °C, temperature class 155 (F) used according to 155 (F)	<b>E11</b>	✓	✓	✓	✓
Without type test certificate according to LR (Lloyds Register), Great Britain, CT 45 °C, temperature class 155 (F) used according to 155 (F)	<b>E21</b>	✓	✓	✓	✓
Without type test certificate according to BV (Bureau Veritas), France, CT 45 °C, temperature class 155 (F) used according to 155 (F)	<b>E31</b>	✓	✓	✓	✓
Without type test certificate according to DNV (Det Norske Veritas), Norway, CT 45 °C, temperature class 155 (F) used according to 155 (F)	<b>E51</b>	✓	✓	✓	✓
Without type test certificate according to ABS (American Bureau of Shipping), USA, CT 50 °C, temperature class 155 (F), used according to 155 (F)	<b>E61</b>	✓	✓	✓	✓
Without type test certificate according to CCS (Chinese Classification Society), China, CT 45 °C, temperature class 155 (F), used according to 155 (F)	<b>E71</b>	✓	✓	✓	✓
Motor for use in shipping, higher ambient temperature and/or used as temperature class 155 (F) according to 130 (B)	<b>E80 + plain text details</b>	✓	✓	✓	✓
<b>Acceptance/certification</b>					
Individual acceptance by marine classification society	<b>E10</b>	✓	✓	✓	✓
Individual acceptance by marine classification society with supervision of construction and acceptance test certificate 3.2 according to EN 10204	<b>E09</b>	✓	✓	✓	✓
Type test with heat run for horizontal motors, with acceptance	<b>F83 <sup>2)</sup></b>	✓	✓	✓	✓
Type test with heat run for vertical motors, with acceptance	<b>F93 <sup>2)</sup></b>	✓	✓	✓	✓

✓ With additional charge

### Explosion-proof motors frame size 315 and above in marine version (individual acceptance required)

Special versions	Order No. supplement <b>-Z</b> with order code and/or plain text details	Motor type frame size			
		315	355	400	450
<b>Self-ventilated motors in Zone 22 with type of protection “n” or protection against dust explosions</b>					
		<b>1LA8 (cast-iron)</b>			
<b>Basic marine version <sup>1)</sup></b>					
Without type test certificate according to GL (Germanischer Lloyd), Germany, CT 45 °C, temperature class 155 (F) used according to 155 (F)	<b>E11</b>	✓	✓	✓	✓
Without type test certificate according to LR (Lloyds Register), Great Britain, CT 45 °C, temperature class 155 (F) used according to 155 (F)	<b>E21</b>	✓	✓	✓	✓
Without type test certificate according to BV (Bureau Veritas), France, CT 45 °C, temperature class 155 (F) used according to 155 (F)	<b>E31</b>	✓	✓	✓	✓
Without type test certificate according to DNV (Det Norske Veritas), Norway, CT 45 °C, temperature class 155 (F) used according to 155 (F)	<b>E51</b>	✓	✓	✓	✓
Without type test certificate according to ABS (American Bureau of Shipping), USA, CT 50 °C, temperature class 155 (F), used according to 155 (F)	<b>E61</b>	✓	✓	✓	✓
Without type test certificate according to CCS (Chinese Classification Society), China, CT 45 °C, temperature class 155 (F), used according to 155 (F)	<b>E71</b>	✓	✓	✓	✓
Motor for use in shipping, higher ambient temperature and/or used as temperature class 155 (F) according to 130 (B)	<b>E80 + plain text details</b>	✓	✓	✓	✓
<b>Acceptance/certification</b>					
Individual acceptance by marine classification society	<b>E10</b>	✓	✓	✓	✓
Individual acceptance by marine classification society with supervision of construction and acceptance test certificate 3.2 according to EN 10204	<b>E09</b>	✓	✓	✓	✓
Type test with heat run for horizontal motors, with acceptance	<b>F83 <sup>2)</sup></b>	✓	✓	✓	✓
Type test with heat run for vertical motors, with acceptance	<b>F93 <sup>2)</sup></b>	✓	✓	✓	✓

✓ With additional charge

<sup>1)</sup> The order codes for the basic marine version (**E11, E21, E31, E51, E61, E71, E80**) cannot be combined with each other.

<sup>2)</sup> Option only necessary for one motor when ordering several motors of the same type. Type testing is also performed for converter-fed operation.

# IEC Squirrel-Cage Motors

## Marine motors

### Accessories

#### Overview

See the relevant sections in catalog parts 2 "Standard motors up to frame size 315 L", 3 "Non-standard motors frame size 315 and above", 4 "Explosion-proof motors", 7 "Fan motors" and 9 "Smoke-extraction motors".

### Dimensions

#### Overview

See dimensions in catalog parts 2 "Standard motors up to frame size 315 L", 3 "Non-standard motors frame size 315 and above", 4 "Explosion-proof motors" and 7 "Fan motors", 9 "Smoke-extraction motors".

# IEC Squirrel-Cage Motors

## Marine motors

Notes

10



# Appendix



<b>11/2</b>	<b>Overview of products</b>
11/2	SIMATIC ET 200S FC/ SIMATIC ET 200pro FC
11/4	SINAMICS G110
11/5	SINAMICS G120
11/7	SINAMICS G120D
11/7	MICROMASTER 410/420/430/440
11/8	MICROMASTER 411/ COMBIMASTER 411
11/9	Customized motors
11/10	Motors acc. to NEMA standard
<b>11/11</b>	<b>SD configurator selection tool</b>
<b>11/13</b>	<b>Energy-saving program SinaSave</b>
<b>11/14</b>	<b>SIZER configuration tool</b>
<b>11/15</b>	<b>STARTER commissioning tool</b>
<b>11/17</b>	<b>Training</b>
11/18	Training courses for drive systems
11/18	The courses at a glance
<b>11/19</b>	<b>SD Manual Collection</b>
<b>11/20</b>	<b>Siemens Contacts Worldwide</b>
<b>11/21</b>	<b>Online Services– Information and Ordering in the Internet and on DVD</b>
11/21	Siemens Industry Automation and Drive Technologies in the WWW
11/21	Product Selection Using the Offline Mall
11/21	Easy Shopping with the A&D Mall
<b>11/22</b>	<b>Customer Support</b>
11/22	Online Support
11/22	Technical Support
11/22	Technical Consulting
11/22	Configuration and Software Engineering
11/22	Service on Site
11/22	Repairs and Spare Parts
11/22	Optimization and Upgrading
11/23	Knowledge Base on CD-ROM
11/23	Automation Value Card
<b>11/24</b>	<b>Subject index</b>
<b>11/30</b>	<b>Index of Order No.</b>
<b>11/33</b>	<b>Overview of order codes</b>
<b>11/44</b>	<b>Metal surcharges</b>
<b>11/46</b>	<b>Conditions of sale and delivery, Export regulations</b>

# IEC Squirrel-Cage Motors

## Appendix

### Overview of products

#### Frequency converters for SIMATIC ET 200 distributed I/O

Frequency converters are available for the SIMATIC ET 200 distributed I/O that are fully system-integrated modules. Converters are available for the finely modular SIMATIC ET 200S FC system to the IP20 degree of protection as well as for the cabinet-free SIMATIC ET 200pro FC system to the IP65 degree of protection. With a broad range of possibilities, the frequency converters expand the functional scope of the modular modules that are available in both systems (e.g. inputs and outputs, technology modules, direct and soft starters). With suitable interface modules, connection to PROFIBUS and PROFINET is possible via the SIMATIC ET 200 system bus as well as integration of PLC functionality into the system. Fail-safe frequency converter functions can be activated locally or via PROFIsafe.

An overview of the features of these frequency converters is given in the tables below. The complete product spectrum including ordering data, technical data and explanations can be found in Catalog IK PI "Industrial Communication" and on the Internet at

<http://www.siemens.com/et200s-fc>

and

<http://www.siemens.com/et200pro-fc>

SIMATIC ET 200S FC	
Main features	<ul style="list-style-type: none"> <li>• Complete embedding of a frequency converter into a distributed I/O system to IP20 degree of protection</li> <li>• Easy assembly and low susceptibility to errors thanks to self-assembling energy and communications bus</li> <li>• Space-saving assembly thanks to compact dimensions and common protection</li> <li>• Fast, tool-free replacement of the frequency converter for a servicing requirement (hot swapping)</li> <li>• Frequency control (<math>V/f</math>), vector control with and without encoders</li> <li>• Line-commutated regenerative feedback by power electronics of the latest generation</li> <li>• Modular structure with Control Unit (closed-loop control module) and Power Module (power section)</li> <li>• Frequency inverter variant with integrated, autonomous, fail-safe functions without the need for complex external wiring</li> </ul>
Rated outputs	0.75 kW, 2.2 kW, 4.0 kW
Input voltage	380 ... 480 V 3 AC $\pm 10$ %
Overall width	Control Unit + Power Module up to 0.75 kW: 80 mm, otherwise 145 mm
Mains frequency	47 ... 63 Hz
Overload capability	<ul style="list-style-type: none"> <li>• Overload current <math>1.5 \times</math> rated output current (i.e. 150 % overload) over 60 s, cycle time 300 s</li> <li>• Overload current <math>2 \times</math> rated output current (i.e. 200 % overload) over 3 s, cycle time 300 s</li> </ul>
Output frequency	0 ... 650 Hz
Pulse frequency	8 kHz (standard), 2 ... 16 kHz (in steps of 2 kHz)
Frequency bands that can be skipped	1, programmable
Efficiency	$\geq 96$ %
Interfaces	<ul style="list-style-type: none"> <li>• Connection to PROFIBUS via IM151 interface module</li> <li>• Connection to PROFINET via IM151-3PN interface module</li> <li>• Integration of PLC functionality through IM151 CPU and IM151-7 F CPU interface modules</li> <li>• RS232 interface with USS protocol for commissioning on the PC with the STARTER commissioning software</li> <li>• Slot for an optional Micro Memory Card for uploading or downloading parameter settings</li> <li>• PTC/KTY84 interface for motor monitoring</li> <li>• Speed sensor interface (Sub-D connector) for unipolar HTL incremental encoder</li> <li>• Activation of the integrated safety functions over PROFIsafe (using the PM-D F PROFIsafe Power Module) or terminals (using the Safety Local Power Module PM-D F X1)</li> </ul>
Standards conformance	UL, cUL, CE and c-tick, Low-Voltage Directive 73/23/EEC, EMC Directive 89/336/EEC
Functional safety	<p>Closed-loop control module with Integral safety functions to Category 3 of EN 954-1 and SIL2 of IEC 61508:</p> <ul style="list-style-type: none"> <li>• Safety torque off</li> <li>• Safely limited speed</li> <li>• Safe stop 1</li> </ul> <p>The safety functions "Safely limited speed" and "Safe stop 1" are certified for encoderless asynchronous motors. These safety functions are not approved for pull-through loads as in the case of lifting gear and winders</p>
Degree of protection	IP20

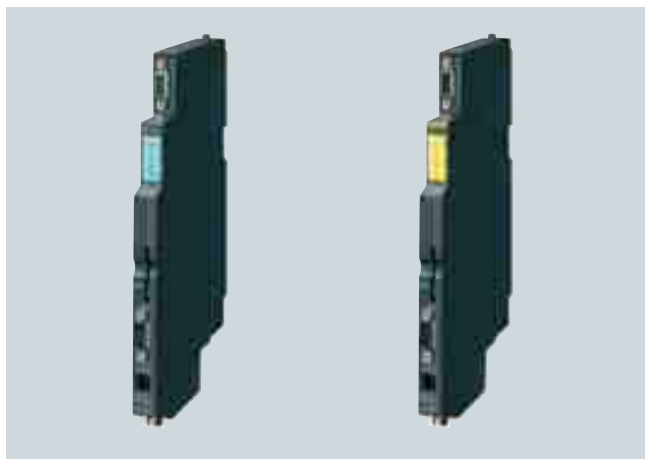

SIMATIC ET 200S FC  
Control Units



SIMATIC ET 200S FC  
Power Modules

SIMATIC ET 200pro FC	
Main features	<ul style="list-style-type: none"> <li>• Complete embedding of a frequency converter into a distributed I/O system to IP65 degree of protection</li> <li>• Easy assembly and low susceptibility to errors thanks to self-assembling energy and communications bus</li> <li>• Fast replacement of the frequency converter during servicing without interruption of the bus communication to other modules within the SIMATIC ET 200pro FC</li> <li>• Frequency control (<math>V/f</math>), vector control without encoders</li> <li>• Line-commutated regenerative feedback by power electronics of the latest generation</li> <li>• Frequency converter variant with integrated, autonomous, fail-safe functions without the need for complex external wiring</li> </ul>
Rated outputs	1.1 kW (at 0 ... 55 °C ambient temperature) 1.5 kW (at 0 ... 45 °C ambient temperature)
Input voltage	380 ... 480 V 3 AC $\pm 10$ %
Overall width	155 mm
Mains frequency	47 ... 63 Hz
Overload capability	<ul style="list-style-type: none"> <li>• Overload current <math>1.5 \times</math> rated output current (i.e. 150 % overload) over 60 s, cycle time 300 s</li> <li>• Overload current <math>2 \times</math> rated output current (i.e. 200 % overload) over 3 s, cycle time 300 s</li> </ul>
Output frequency	0 ... 650 Hz
Pulse frequency	4 kHz (standard) 2 ... 16 kHz (in steps of 2 kHz)
Frequency bands that can be skipped	1, programmable
Efficiency	$\geq 96$ %
Interfaces	<ul style="list-style-type: none"> <li>• Connection to PROFIBUS through IM154-1 and IM154-2 interface modules</li> <li>• Available soon connection to PROFINET over IM154-4PN interface modules and connection to IM154-8 CPU interface modules</li> <li>• Optical interface with USS protocol for fiber-optic RS232 connecting cable</li> <li>• Control signal for 180 V DC electromagnetic motor brake</li> <li>• Slot for an optional memory card (MMC) for uploading or downloading parameter settings</li> <li>• PTC/KTY84 interface for motor temperature monitoring</li> <li>• Activation of the integrated safety functions through the Safety Local Isolator Module F RSM or through F-Switch PROFIsafe</li> </ul>
Standards conformance	UL, cUL, CE, Low-Voltage Directive 73/23/EEC, EMC Directive 89/336/EEC
Functional safety	<p>Variant with Integral safety functions to Category 3 of EN 954-1 and SIL2 of IEC 61508:</p> <ul style="list-style-type: none"> <li>• Safety torque off</li> <li>• Safely limited speed</li> <li>• Safe stop 1</li> </ul> <p>The safety functions "Safely limited speed" and "Safe stop 1" are certified for encoderless asynchronous motors. These safety functions are not approved for pull-through loads as in the case of lifting gear and winders</p>
Degree of protection	IP65



SIMATIC ET 200pro FC  
Standard frequency converter



SIMATIC ET 200pro FC-Failsafe  
Frequency converter with integrated safety functions

# IEC Squirrel-Cage Motors

## Appendix

### Overview of products

#### SINAMICS G110 chassis inverters

The SINAMICS G110 chassis inverter is a flexible drive. The table shows an overview of the features of this product. You will find the complete product spectrum with ordering data, technical specifications and descriptions in Catalog D 11.1

“SINAMICS G110/SINAMICS G120 Inverter Chassis Units and SINAMICS G120D Distributed Frequency Inverters” and on the Internet at <http://www.siemens.com/sinamics-g110>

SINAMICS G110	
Main characteristics	“ <b>The versatile drive in the low power range</b> ” is the frequency inverter for inverter chassis units, SINAMICS G110 which can be used for a wide range of industrial drive applications using variable speeds. The particularly compact SINAMICS G110 inverter uses voltage/frequency control ( $U/f$ ) and is the ideal frequency inverter solution in the lower output and performance ranges of the SINAMICS product family. The inverter is available in three frame sizes for connection to single-phase supply systems.
<b>Electrical Data</b>	
Mains voltages, power range	1 AC 200 V ... 240 V, $\pm 10\%$ ; 0.12 kW ... 3.0 kW
Network types	IT, TN, TT
Power frequency	50/60 Hz
Output frequency	0 Hz ... 650 Hz
Control methods	$U/f$ control, linear ( $M-n$ ) $U/f$ control, quadratic ( $M-r^2$ ) $U/f$ control, programmable
Fixed frequencies	3, programmable
Skipped frequency ranges	1, programmable
Digital inputs	3 programmable 24 V DC digital inputs
Analog input (for analog version)	1 analog input for setpoints from 0 V to 10 V, scaleable or for use as 4th digital input
Digital output	1 digital output 24 V DC
Communication interface (for USS version)	RS 485 serial interface for use with USS protocol
Software functions	<ul style="list-style-type: none"> <li>• Automatic restart following interruptions in operation due to a power failure</li> <li>• Smooth connection of the converter to the rotating motor</li> <li>• Programmable ramp-up/ramp-down times</li> <li>• Ramp smoothing</li> </ul>
<b>Functions</b>	
Protective functions	<ul style="list-style-type: none"> <li>• Undervoltage</li> <li>• Overvoltage</li> <li>• Ground fault</li> <li>• Short-circuit</li> <li>• Stall prevention</li> <li>• Thermal motor protection <math>I^2t</math></li> <li>• Converter overtemperature</li> <li>• Motor overtemperature</li> </ul>
Connectable motors	Asynchronous motors
<b>Mechanical data</b>	
Degree of protection	IP20
Cooling method for	
• Converters $\leq 0.75$ kW	Finned heat dissipater with convection cooling; version with flat heat dissipater also available
• Converters $> 0.75$ kW	Internal air cooling (integral fan)
<b>Norms</b>	
Compliance with standards	CE, UL, cUL, c-tick



SINAMICS G110 Chassis inverters



#### SINAMICS G120 inverter chassis units

The SINAMICS G120 inverter chassis unit is a modular drive. The table provides an overview of the features of this product. The complete range of products together with ordering data, technical data and explanations are indicated in the

Catalog D 11.1 "SINAMICS G110/SINAMICS G120 Inverter Chassis Units and SINAMICS G120D Distributed Frequency Inverters" and on the Internet at:  
<http://www.siemens.com/sinamics-g120>

SINAMICS G120	
Main features	As <b>"a modular single drive for low and medium outputs"</b> , the frequency inverter of the SINAMICS G120 inverter chassis units can be used for a wide range of industrial drive applications. The SINAMICS G120 frequency inverter distinguishes itself through its modular design (Power Module and Control Unit), and the globally unique integration of numerous innovative functions in safety technology and regenerative feedback into the line supply. There are extensive system components available in the range from 0.37 to 132 kW. This means that the drive units are suitable for a multitude of drive applications.
<b>Electrical data</b>	
Mains voltages, output range	3 AC 380 V ... 480 V, $\pm 10\%$ ; 0.37 kW ... 132 kW
Network types	IT, TN, TT
Mains frequency	47 ... 63 Hz
Output frequency	0 Hz ... 650 Hz
Control method	V/f control, linear ( $M \sim n$ ) V/f control, quadratic ( $M \sim n^2$ ) and parameterizable sensorless vector control, vector control with encoder (closed control loop) Torque control
Fixed frequencies	16, programmable
Digital inputs	up to 9 digital inputs, depending on the Control Unit 24 V DC
Analog input (for the analog version)	up to 2 analog inputs (0 V to 10 V)
Digital output	3 digital inputs
Communication interface	RS485/USS; PROFIBUS; PROFINET
<b>Functions</b>	
Software functions	<ul style="list-style-type: none"> <li>• Programmable ramp-up times 0 ... 650 s, ramp rounding</li> <li>• Automatic restart after interruption of operation due to supply failure</li> <li>• Flying restart</li> <li>• Signals are locally pre-processed using free function blocks</li> <li>• 3 selectable motor data sets</li> <li>• High-quality internal PID controller for simple process control</li> <li>• Positioning ramp down</li> <li>• Kinetic buffering</li> </ul>
Protection functions	<ul style="list-style-type: none"> <li>• Motor temperature (PTC/KTY, <math>P_t</math>)</li> <li>• Power unit and load cycle monitoring</li> <li>• Overvoltage and undervoltage</li> <li>• Earth fault</li> <li>• Stall prevention</li> <li>• System protection functions</li> </ul>
Safety Integrated Functions	STO, SS1, SLS, SBC
Connectable motors	Asynchronous motors
<b>Mechanical data</b>	
Degree of protection	IP20
Cooling method	Innovative cooling concept: The power electronics are cooled by means of heat sinks with an external fan; Open-loop and closed-loop control electronics are cooled by convection
<b>Standards</b>	
Standards complied with	CE, UL, cUL, c-tick, Safety Integrated IEC 61508/SIL 2



SINAMICS G120 inverter chassis units

# IEC Squirrel-Cage Motors

## Appendix

### Overview of products

#### SINAMICS G120D distributed frequency inverter

The SINAMICS G120D frequency inverter is a modular drive. The table provides an overview of the features of this product. The complete range of products together with ordering data, technical data and explanations are indicated in the

Catalog D 11.1 "SINAMICS G110/SINAMICS G120 Inverter Chassis Units and SINAMICS G120D Distributed Frequency Inverters" and on the Internet at:

<http://www.siemens.com/sinamics-g120d>

SINAMICS G120D	
Main features	<b>"The modular drive for low and medium outputs"</b> – the SINAMICS G120D distributed frequency inverter can be especially used for sophisticated conveyor applications in industry as for many other high-performance applications. The distributed SINAMICS G120D frequency inverter distinguishes itself through its modular design (Power Module and Control Unit) as well as through its extremely flat type of construction, an identical drilling template for all outputs and a high degree of safety. It offers safety functions that are unique in its class. It helps to save significant amounts of energy as a result of its line-commutated regenerative feedback capability. It goes without saying that the frequency inverter is also capable of communications.
<b>Electrical data</b>	
Mains voltages, output range	3 AC 380 V ... 480 V, $\pm 10\%$ ; 0.75 kW ... 7.5 kW
Network types	IT, TN, TT
Mains frequency	47 ... 63 Hz
Output frequency	0 Hz ... 650 Hz
Control method	V/f control, linear ( $M \sim n$ ) V/f control, quadratic ( $M \sim n^2$ ) and parameterizable sensorless vector control, vector control with encoder (closed control loop) Torque control
Fixed frequencies	16, programmable
Digital inputs	up to 6 digital inputs, depending on the Control Unit 24 V DC
Analog input (for the analog version)	up to 2 analog inputs (0 V to 10 V)
Digital output	3 digital inputs
Communication interface	PROFIBUS; PROFINET
<b>Functions</b>	
Software functions	<ul style="list-style-type: none"> <li>• Programmable ramp-up times 0 ... 650 s, ramp rounding</li> <li>• Automatic restart after interruption of operation due to supply failure</li> <li>• Flying restart</li> <li>• Signals are locally pre-processed using free function blocks</li> <li>• 3 selectable motor data sets</li> <li>• High-quality internal PID controller for simple process control</li> <li>• Positioning ramp down</li> <li>• Kinetic buffering</li> </ul>
Protection functions	<ul style="list-style-type: none"> <li>• Motor temperature (PTC/KTY, <math>Pt</math>)</li> <li>• Power unit and load cycle monitoring</li> <li>• Overvoltage and undervoltage</li> <li>• Earth fault</li> <li>• Stall prevention</li> <li>• System protection functions</li> </ul>
Safety Integrated Functions	STO, SS1, SLS
Connectable motors	Asynchronous motors
<b>Mechanical data</b>	
Degree of protection	IP65
Cooling method	Convection cooling, for higher outputs with fan
<b>Standards</b>	
Standards complied with	CE, UL, cUL, c-tick, Safety Integrated IEC 61508/SIL 2



SINAMICS G120D distributed frequency inverter

#### MICROMASTER 410/420/430/440 frequency converters

MICROMASTER converters from Siemens perfectly complement the motors. The table shows an overview of the features of these converters. For the full range of products complete with ordering data, technical details and explanations, see Catalog DA 51.2.

For up-to-date information on MICROMASTER 420/430/440 frequency converters, visit the Internet at <http://www.siemens.com/micromaster>

	MICROMASTER 410	MICROMASTER 420	MICROMASTER 430	MICROMASTER 440
Main characteristics	<b>"The low-price solution"</b> for variable speeds with three-phase motors on single-phase networks, e.g. with pumps, fans, billboards, barriers, gate drives and automatic machines <b>Discontinued model<sup>1)</sup></b>	<b>"The universal converter"</b> for three-phase networks and optional fieldbus interfacing, e.g. for conveyor belts, material transport, pumps, fans and machine tools	<b>"The specialist for pumps and fans"</b> with optimized OP (manual/automatic changeover), adapted software functionality and optimised output utilization	<b>"The all-rounder"</b> with advanced vector control (with and without encoder feedback) for versatile applications in sectors such as conveyor systems, textiles, lifts, lifting gear and machine construction
Output range	0.12 kW ... 0.75 kW	0.12 kW ... 11 kW	7.5 kW ... 250 kW	0.12 kW ... 250 kW
Voltage ranges	1 AC 100 V ... 120 V 1 AC 200 V ... 240 V	1 AC 200 V ... 240 V 3 AC 200 V ... 240 V 3 AC 380 V ... 480 V	3 AC 380 V ... 480 V	1 AC 200 V ... 240 V 3 AC 200 V ... 240 V 3 AC 380 V ... 480 V 3 AC 500 V ... 600 V
Closed-loop Control	<ul style="list-style-type: none"> <li>V/f characteristic</li> <li>Multipoint characteristic (parameterizable V/f characteristic)</li> <li>FCC (Flux Current Control)</li> </ul>	<ul style="list-style-type: none"> <li>V/f characteristic</li> <li>Multipoint characteristic (parameterizable V/f characteristic)</li> <li>FCC (Flux Current Control)</li> </ul>	<ul style="list-style-type: none"> <li>V/f characteristic</li> <li>Multipoint characteristic (parameterizable V/f characteristic)</li> <li>FCC (Flux Current Control)</li> </ul>	<ul style="list-style-type: none"> <li>V/f characteristic</li> <li>Multipoint characteristic (parameterizable V/f characteristic)</li> <li>FCC (Flux Current Control)</li> <li>Vector control</li> </ul>
Process control	–	Internal PI controller	Internal PID controller	Internal PID controller (autotuning)
Inputs	3 Digital inputs 1 Analog input	3 Digital inputs 1 Analog input	6 Digital inputs 2 Analog inputs 1 PTC/KTY input	6 Digital inputs 2 Analog inputs 1 PTC/KTY input
Outputs	1 Relay output	1 Analog output 1 Relay output	2 Analog outputs 3 Relay outputs	2 Analog outputs 3 Relay outputs
Interfacing to automation system	The PLC partner for LOGO! and SIMATIC S7-200	The ideal partner for your automation tasks, whether with SIMATIC S7-200, SIMATIC S7-300/400 (TIA) or SIMOTION	The ideal partner for your automation tasks, whether with SIMATIC S7-200, SIMATIC S7-300/400 (TIA) or SIMOTION	The ideal partner for your automation tasks, whether with SIMATIC S7-200, SIMATIC S7-300/400 (TIA) or SIMOTION
Additional features	<ul style="list-style-type: none"> <li>Self-ventilated (no fan unit)</li> <li>Position of connections as with conventional switching elements (e.g. contactors)</li> <li>Variant with flat heat sink</li> </ul>	<ul style="list-style-type: none"> <li>BICO technology</li> <li>Compound braking for controlled rapid braking</li> </ul>	<ul style="list-style-type: none"> <li>Energy-saving mode</li> <li>Load torque monitoring (detects dry run of pumps)</li> <li>Motor staging</li> <li>Bypass mode</li> <li>BICO technology</li> </ul>	<ul style="list-style-type: none"> <li>3 selectable drive data records</li> <li>Integrated brake chopper (up to 75 kW)</li> <li>Torque control</li> <li>BICO technology</li> </ul>



Examples of MICROMASTER 410/420/430/440

<sup>1)</sup> The MICROMASTER 410 is a discontinued model since a fairly long time. The type cancellation has been executed as for the 1/10/07 (01.Oct.2007). For this reason, the MICROMASTER is only available as spare part.

# IEC Squirrel-Cage Motors

## Appendix

### Overview of products

#### *Distributed drive solutions – MICROMASTER 411/COMBIMASTER 411 converters and geared motors*

The MICROMASTER 411/COMBIMASTER 411 converters from Siemens are available as a distributed drives solution. The table shows an overview of the features of this product. The complete product spectrum with ordering data, technical details and descriptions can be found in Catalog DA 51.3 MICROMASTER 411/COMBIMASTER 411.

For up-to-date information on MICROMASTER 411 and COMBIMASTER 411 as well as geared motors, visit the Internet at

<http://www.siemens.com/combimaster>

	MICROMASTER 411	COMBIMASTER 411
Main characteristics	"The distributed converter" for a wide drive range, for simple individual applications for pumps and fans through to multiple drives for conveyor systems in networked control systems.	
Output range	0.37 kW ... 3 kW	
Voltage ranges	3 AC 380 V ... 480 V	
Case/ frame sizes	CS B CS C	71 ... 100 90/100
Types of construction		IM B3 IM B5 IM V1 (without protective cover) IM V1 (with protective cover) IM B14 (with standard flange) IM B14 (with special flange) IM B35
Degree of protection	IP65	IP55
Further technical characteristics	<ul style="list-style-type: none"> <li>• V/f characteristic</li> <li>• Multipoint characteristic (parameterisable V/f characteristic)</li> <li>• FCC (Flux Current Control)</li> <li>• Internal PI controller</li> <li>• 3 Digital inputs</li> <li>• 1 Analog input</li> <li>• 1 Relay output</li> <li>• Compound braking for controlled rapid braking</li> <li>• ECOFAST variants with plug connector for power supply, communication interfaces and motor connections to support quick and problem-free replacement. The ECOFAST variants are totally compatible with the ECOFAST technology systems.</li> </ul>	



Examples of MICROMASTER 411



Examples of COMBIMASTER 411

## Overview of products

**Customized motors**

In addition to the products offered in the catalog, our range of motors also includes "Customized motors".

We can develop individual drive solutions for your special requirements, provide samples and supply them in accordance with your logistical requirements.

Our worldwide network of Siemens offices as well as our regional offices in Germany are, of course, at your disposal for advice (see "Siemens Contacts Worldwide").

Please inquire for details.

We have listed below some of the "Customized solutions" already realized:

- High-speed motors for textile machines and compressors
- Motors with increased output/size ratio
- Liquid-cooled motors
- Synchronous generators for standby supply systems
- Motors for wood processing plants
- Built-in motors for refrigerating motors/compressors (freezer proof)
- Rolling motors for harsh conditions (e.g. roller drives)
- Pump motors with special shafts/special materials
- Single-phase motors for industrial applications
- Lifting gear motors



Built-in motor for refrigeration



Pump motor with special shaft/special materials



Roller motor for harsh conditions



Lifting gear motor

# IEC Squirrel-Cage Motors

## Appendix

### Overview of products

#### NEMA motors

For compliance with the local specifications of the NAFTA markets (USA, Canada and Mexico), we manufacture low-voltage motors acc. to the NEMA standard for a wide range of different application areas. This includes motors designed in accordance with the US act, EPACT (specified minimum efficiency levels), as well as motors with NEMA premium efficiency levels: Our NEMA motor series provide the highest operating reliability and maximum service life. Designed and manufactured for rugged oper-

ation, our NEMA motors conquer even the harshest industrial conditions strictly in accordance with the ISO 9001 international quality standard; with maximum performance, reliability and efficiency.

You will find the complete product spectrum with ordering data, technical specifications and information in Catalog D 81.2 U.S./Canada on the Internet at <http://www.sea.siemens.com/motors>

NEMA motors (NEMA = National Electrical Manufacturers Association)	
Frame size	NEMA frame size 56 ... 449
Output range	0.25 HP ... 500 HP
Number of poles	2/4/6/8
Voltages	3 AC 230/460/575 V
Frequency	60 Hz, 50 Hz on request
Type of construction	Foot-mounted, D flange, C flange, P flange
Casing	Cast-iron, aluminum or steel depending on the version
Cooling method	Surface-cooling or internal ventilation depending on the version
Temperature class	F used acc. to B
Type spectrum	<p><b>General purpose motors</b></p> <ul style="list-style-type: none"> <li>• Legally specified minimum efficiency levels or NEMA premium efficiency levels</li> <li>• Standard motors for general industrial use</li> <li>• Aluminum or cast-iron case depending on the version</li> </ul> <p><b>Severe duty motors</b></p> <ul style="list-style-type: none"> <li>• Legally specified minimum efficiency levels or NEMA premium efficiency levels</li> <li>• Cast-iron case</li> <li>• Motors for use under extremely difficult environmental conditions</li> </ul> <p><b>Severe duty IEEE841 motors</b></p> <ul style="list-style-type: none"> <li>• Efficiency levels required by IEEE that exceed the EPACT act</li> <li>• Motors with increased requirements for use in the petrochemical industry (according to IEEE841)</li> <li>• Cast-iron case</li> </ul> <p><b>Explosion-proof motors</b></p> <ul style="list-style-type: none"> <li>• Efficiency levels better than or equal to EPACT</li> <li>• Multi label according to Division 1, Class I, Group D and Class II, Groups F&amp;G</li> <li>• Single label according to Division 1, Class I, Groups C&amp;D</li> </ul>



Example of NEMA motor, Severe Duty SD100, cast-iron case



Example of NEMA motor, General Purpose GP10A, aluminum case

### Overview

#### Product description

The SD configurator has been developed to facilitate the selection of a correct motor and/or converter from the wide spectrum of Standard Drives. It is integrated as an offline "selection tool" in the interactive catalog CA01 (DVD) and is also available online in the Mall. The SD configurator is used to find the correct drive solution and delivers both the correct order number and relevant documentation.



It can display operating instructions, factory test certificates, connection box documentation, etc. and generates data sheets, dimension drawings and a start-up calculation for the relevant products. It can also be used to identify a suitable converter for the selected motor.

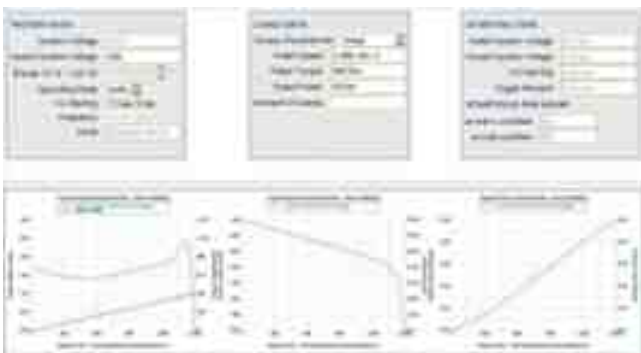

3D models in a wide variety of 3D formats are also available.



The comprehensive help system not only explains the program functions, but also provides access to detailed technical background knowledge.

#### Product range

The SD configurator covers the product range of low-voltage motors (energy-saving and explosion-proof motors) with associated documentation and dimension drawings, low-voltage converters of the MICROMASTER 4 range, SINAMICS G110 and SINAMICS G120 inverter chassis units, SINAMICS G120D distributed frequency inverters and the frequency inverters for the SIMATIC ET 200S FC and SIMATIC ET 200pro distributed I/Os.

#### Hardware and software requirements

- PC with 1.5 GHz CPU or faster
- Operating systems
  - Windows 98/ME
  - Windows 2000
  - Windows XP
  - Windows NT (Service Pack 6 and higher)
  - Windows Vista
- At least 1024 Mbyte RAM user memory
- Screen resolution 1024 × 768, graphics with more than 256 colors/small fonts
- CD-ROM/DVD-drive
- Windows-compatible sound card
- Windows-compatible mouse

# IEC Squirrel-Cage Motors

## Appendix

### SD configurator selection tool

#### Offline access to catalog CA01 – the Offline Mall



The interactive catalog CA 01 on DVD – the offline mall of Siemens Industry Automation and Drive Technologies – contains over 100000 products with approximately 5 million potential drive system product variants.

You can install catalog CA01 on your hard disk or network directly from the DVD as a light or full version. You find the SD configurator in the main menu of catalog CA01 under the tab "Selection tool".

#### Online access in the Siemens Mall

Furthermore, the SD configurator can now be used on the Internet without installation. The SD configurator can be found in the Siemens Mall under the following address:

<http://www.siemens.com/sd-configurator>



### Selection and ordering data

	Order No.
Interactive Catalog CA 01 on DVD including SD configurator selection tool, English	<b>E86060-D4001-A510-C7-7600</b>

### More information

The interactive catalog CA 01 can be ordered from the relevant Siemens sales office or via the Internet:

<http://www.siemens.com/automation/CA01>

Links to hints, tricks and downloads for functional or content updates can also be found at this address.

For technical advice and hotline support, you can also contact our hotline for Catalog CA 01:

Tel.: +49 (0) 180 50 50 22 2

e-mail: [adsupport@siemens.com](mailto:adsupport@siemens.com)



#### Overview

The energy-saving program SinaSave is suitable for applications with motors for mains-fed operation (fixed speed) and converter-fed operation (variable speed). In mains-fed operation, you can calculate the cost savings as well as the amortization time for the additional cost of the Siemens EFF1 energy-saving motors with the three bases of comparison outlined below.

In comparison to:

- Siemens EFF2 energy-saving motors – **Case 1**
- Individually selected known motors – **Case 2**
- Known motors within an overall plant analysis – **Case 3**

The individual applications are:

#### Case 1

Calculation of the savings in energy costs as well as the amortization time for the additional cost of the Siemens EFF1 energy-saving motors as compared to the Siemens EFF2 energy-saving motors.

In this case, the motor data for the Siemens energy-saving motors have already been stored complete with their order numbers. In addition, you are told how long it will take until the additional cost for an energy-saving motor will pay for itself.



#### Case 2

Calculation of the savings in energy costs as well as the amortization time for the additional cost of the Siemens EFF1 energy-saving motors in comparison with other known motors.

The calculation, however, requires exact knowledge of the technical specifications of the motor which is to be used for comparison.

#### Case 3

Calculation of the savings in energy costs as well as the amortization time for the additional cost of Siemens EFF1 energy-saving motors in comparison with any number of other known motors – plant analysis.

In **converter-fed operation**, SinaSave takes into account all the necessary plant-specific parameters. Values required for the process such as pumping flowrate and height for pumps, mass flowrate and total pressure difference for fans as well as the density of the transported medium are taken into account in addition to the efficiency of the fan, pump or compressor, the electrical efficiency and the overall efficiency of the plant. Other basic data for the program include the number of working days and work shifts as well as the medium transport profile that decides the extent of the energy-saving effect throughout the day and the year.

From the entered plant-specific basic data, the program first obtains the drive system with the appropriate output and the price of the corresponding frequency converter. In a further step, the program determines the energy requirements of the variable-speed drive system for the specific application and compares it to the calculated values for all alternative concepts that can be considered for the plant in question; including for example, throttle valves, bypass, pre-forming control or pole-changing motors. The energy-saving is obtained from the difference in kilowatt hours which the program then converts into a cash saving using the currently applicable energy purchasing price for the plant.

The program calculates the amortization time from the price of the frequency converter, the decisive energy-saving and other cost-reducing effects of variable-speed operation that have also been taken into account, such as an improved power factor and smoother running of equipment.

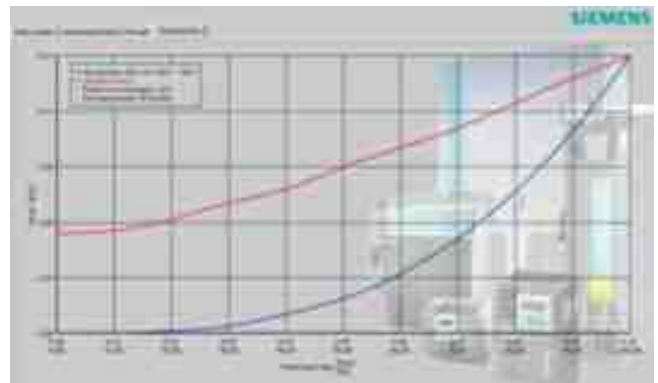

#### Product range

The SinaSave program covers the product range of low-voltage motors/energy-saving motors and low-voltage converters of the MICROMASTER 430 and 440 product range, as well as the SINAMICS G150 drive converter chassis units.

#### More information

The program can be downloaded from the Internet using the following link:

<http://www.siemens.com/energysaving>

# IEC Squirrel-Cage Motors

## Appendix

### SIZER configuration tool

#### Overview



The SIZER configuration tool provides an easy-to-use means for configuring the following drives and controls:

- SINAMICS drive family
- MICROMASTER 4 drive family
- CNC control SINUMERIK solution line
- SIMOTION Motion Control
- SIMATIC technology

It provides support when setting up the technologies involved in the hardware and firmware components required for a drive task. SIZER supports the complete configuration of the drive system, from simple individual drives to complex multi-axis applications.

SIZER supports all of the engineering steps in one workflow:

- Configuring the power supply
- Motor and gearbox design, including calculation of mechanical transmission elements
- Configuring the drive components
- Selecting the required accessories
- Selecting the line-side and motor-side power options, e.g. cables, filters, and reactors

When SIZER was being designed, particular importance was placed on high usability and a universal, function-based approach to the drive task. The extensive user guidance makes using the tool easy. Status information keeps you continually informed of the progress of the configuration process.

The SIZER user interface is available in German, English, French and Italian.

The drive configuration is saved in a project. In the project, the components and functions used are displayed in a hierarchical tree structure.

The project view permits the configuration of drive systems and the copying/inserting/modifying of drives already configured.

The configuration process produces the following results:

- A parts list of the components required (export to Excel, use of the Excel data sheet for import to VSR)
- Technical specifications of the system
- Characteristic curves
- Comments on system reactions
- Location diagram of drive and control components and dimension drawings of motors

These results are displayed in a results tree and can be reused for documentation purposes.

Support is provided by the technological online help menu:

- Detailed technical data
- Information about the drive systems and their components
- Decision-making criteria for the selection of components

Online help in German, English, French, Italian, Chinese and Japanese

#### Minimum system requirements

PG or PC with Pentium II 400 MHz (Windows 2000), Pentium III 500 MHz (Windows XP)

512 MB RAM (1024 MB RAM recommended)

At least 2.7 GB of free hard disk space

An additional 100 MB of free hard disk space on Windows system drive

Screen resolution 1024 × 768 pixels

Windows 2000 SP4 / XP Professional SP2 / XP Home Edition SP2

Microsoft Internet Explorer 5.5 SP2

#### Selection and ordering data

Order No.

SINAMICS MICROMASTER SIZER configuration tool  
German, English, French, Italian

**6SL3070-0AA00-0AG0**

#### Overview

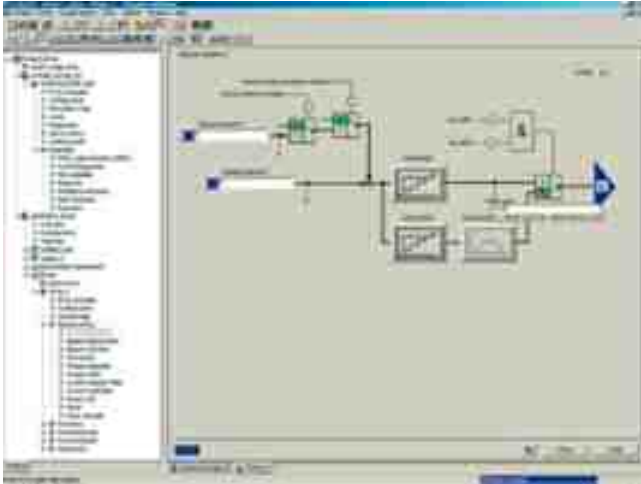

The easy-to-use STARTER commissioning tool can be used to:

- Start up
- Optimize and
- Diagnose

This software can be operated either as a stand-alone PC application or can be integrated into the SCOUT engineering system (on SIMOTION) or STEP 7 (with Drive ES Basic). The basic functions and handling are the same regardless.

In addition to the SINAMICS drives, the current version of STARTER also supports MICROMASTER 4 devices and inverters for the SIMATIC ET 200S FC and SIMATIC ET 200pro FC distributed I/O system.

The project wizards can be used to create the drives within the structure of the project tree.

Beginners are supported by solution-based dialog guidance, whereby a standard graphics-based display maximizes clarity when setting the drive parameters.

First commissioning is guided by wizards, which make all the basic settings in the drive. This ensures that even though only a small number of parameter settings have been made, the drive configuration has already progressed far enough to permit axis movement.

The individual settings required are made using graphics-based parameterization screen forms, which also display the mode of operation.

Examples of individual settings that can be made include:

- Terminals
- Bus interface
- Setpoint channel (e.g. fixed setpoints)
- Closed-loop speed control (e.g. ramp-function generator, limits)
- BICO interconnections
- Diagnostics

Experts can gain rapid access to the individual parameters via the Expert List and do not have to navigate dialogs.

In addition, the following functions are available for optimization purposes:

- Self-optimization (depending on drive)
- Trace (depending on drive)

Diagnostics functions provide information about:

- Control/status Words
- Parameter status
- Operating conditions
- Communication states

#### Performance

- Easy to use: Only a small number of settings need to be made for successful first commissioning: Axis turning
- Solution-oriented dialog-based user guidance simplifies commissioning.
- Self-optimization functions reduce manual effort for optimization.
- The built-in trace function provides optimum support during commissioning, optimization and troubleshooting

#### Minimum hardware and software requirements

PG device or PC with Pentium III 1 GHz (Windows 2000), Pentium III 1 GHz (Windows XP)

512 MB RAM (1 GB RAM recommended)

Screen resolution 1024 × 768 pixels, 16-bit color depth

Free hard disk memory: 1.6 GB, 2.3 GB for SCOUT stand-alone

Windows XP Professional SP2

Microsoft Internet Explorer 6.0

# IEC Squirrel-Cage Motors

## Appendix

### STARTER commissioning tool

#### Integration

Depending on the system configuration, the Control Unit (CU) or the complete converter can communicate with the programming device (PG) or PC by means of a serial interface, via PROFIBUS or PROFINET.

The following accessories are available for this purpose for the respective drive system:

##### *SINAMICS G130/G150/S120*

A PROFIBUS communications board and a connection cable are required for the communication between the PG/PC and a Control Unit.

For example a PROFIBUSCP 5512 communications board (PCMCIA card type 2 + adapter with 9-pole SUB-D socket for connection to PROFIBUS. For MS Windows 2000/XP Professional and PCMCIA 32)

Order No.: 6GK1551-2AA00

and connection cable between CP 5512 and PROFIBUS

Order No.: 6ES7901-4BD00-0XA0

##### *SINAMICS G110/G120 and MICROMASTER 4*

PC inverter connection kits are available for MICROMASTER 4, SINAMICS G110 and SINAMICS G120 for a safe point-to-point connection to the PC.

Order No. for MICROMASTER 4: 6SE6400-1PC00-0AA0 (the scope of supply includes a 9-pin Sub-D connector, an RS232 standard cable (3 m))

Order No. for SINAMICS G110 and SINAMICS G120: 6SL3255-0AA00-2AA1

(the scope of supply includes a 9-pin Sub-D connector, an RS232 standard cable (3 m) and the STARTER commissioning tool on DVD)

#### Selection and ordering data

	Order No.
<b>STARTER commissioning tool for SINAMICS and MICROMASTER</b> German/English/French/Italian/Spanish	<b>6SL3072-0AA00-0AG0</b>
<b>Drive Control Chart (DCC) option package for SINAMICS G130/G150/S120</b> German/English/French/Italian/Spanish, Single license Note: DCC can be used only if Version V4.1 SP1 or higher of the STARTER commissioning tool is installed	<b>6AU1810-1HA20-1XA0</b>
<b>PROFIBUS CP 5512 communications board</b> PCMCIA card type 2 + adapter with 9-pole SUB-D socket for connection to PROFIBUS. For MS Windows 2000/XP Professional and PCMCIA 32	<b>6GK1551-2AA00</b>
<b>Connection cable between CP 5512 and PROFIBUS</b>	<b>6ES7901-4BD00-0XA0</b>
<b>PC inverter connection kit for MICROMASTER 4</b> the scope of supply includes a 9-pin Sub-D connector, an RS232 standard cable (3 m)	<b>6SE6400-1PC00-0AA0</b>
<b>PC inverter connection kit for SINAMICS G110/G120</b> the scope of supply includes a 9-pin Sub-D connector, an RS232 standard cable (3 m) and the STARTER commissioning tool on DVD	<b>6SL3255-0AA00-2AA1</b>

#### Options

##### *DRIVE CONTROL CHART (DCC)*

Drive Control Chart (DCC) is an additional tool for the easy configuration of process-oriented functions for the SINAMICS G130 and SINAMICS G150 drives.

The user-friendly DCC editor enables easy graphics-based configuration, a clear representation of control loop structures as well as a high degree of reusability of existing diagrams.

The open-loop and closed-loop control functionality is defined by using multi-instance-enabled blocks (Drive Control Blocks (DCBs)) from a predefined library (DCB library) that are selected and graphically linked by dragging and dropping. Test and diagnostic functions allow verification of program behavior or the identification of causes in the event of faults.

The block library contains a large selection of control, arithmetic and logic blocks as well as extensive open-loop and closed-loop control functions.

Drive Control Chart also provides a convenient basis for SINAMICS S120 for resolving drive-level open-loop and closed-loop control tasks directly in the converter. This results in further adaptability of SINAMICS to specific tasks. On-site processing in the drive supports modular machine concepts and results in increased overall machine performance.

DCC is an add-on to the STARTER commissioning tool for the aforementioned drives SINAMICS G130, SINAMICS G150 and SINAMICS S120 and available as a supplementary option package.

#### More information

The STARTER commissioning tool can also be downloaded from the Internet at

<http://support.automation.siemens.com/WWW/view/en/10804985/133100>

### Faster and more applicable know-how: Hands-on training from the manufacturer

**SITRAIN®** – the Siemens Training for Automation and Industrial Solutions – provides you with comprehensive support in solving your tasks.

Training by the market leader in automation and plant engineering enables you to make independent decisions with confidence. Especially where the optimum and efficient use of products and plants are concerned. You can eliminate deficiencies in existing plants, and exclude expensive faulty planning right from the beginning.



**First-class know-how directly pays for itself: In shorter start-up times, high-quality end products, faster troubleshooting and reduced downtimes. In other words, increased profits and lower costs.**

#### Achieve more with SITRAIN

- Shorter times for startup, maintenance and servicing
- Optimized production operations
- Reliable configuration and startup
- Minimization of plant downtimes
- Flexible plant adaptation to market requirements
- Compliance with quality standards in production
- Increased employee satisfaction and motivation
- Shorter familiarization times following changes in technology and staff

#### Contact

Visit our site on the Internet at:

[www.siemens.com/sitrain](http://www.siemens.com/sitrain)

or let us advise you personally. You can request our latest training catalog from:

#### SITRAIN Customer Support Germany:

Phone: +49 (0)1805 / 23 56 11  
(0.14 €/min. from the German landline network)

Fax: +49 (0)1805 / 23 56 12

### SITRAIN highlights

#### Top trainers

Our trainers are skilled teachers with direct practical experience. Course developers have close contact with product development, and directly pass on their knowledge to the trainers.

#### Practical experience

The practical experience of our trainers enables them to teach theory effectively. But since theory can be pretty drab, we attach great importance to practical exercises which can comprise up to half of the course time. You can therefore immediately implement your new knowledge in practice. We train you on state-of-the-art methodically/didactically designed training equipment. This training approach will give you all the confidence you need.

#### Wide variety

With a total of about 300 local attendance courses, we train the complete range of A&D products as well as interaction of the products in systems. Telecourses, teach-yourself software and seminars with a presenter on the Web supplement our classic range of courses.

#### Tailor-made training

We are only a short distance away. You can find us at more than 50 locations in Germany, and in 62 countries worldwide. You wish to have individual training instead of one of our 300 courses? Our solution: We will provide a program tailored exactly to your personal requirements. Training can be carried out in our Training Centers or at your company.

#### The right mixture: Blended learning

“Blended learning” means a combination of various training media and sequences. For example, a local attendance course in a Training Center can be optimally supplemented by a teach-yourself program as preparation or follow-up. Additional effect: Reduced traveling costs and periods of absence.



# IEC Squirrel-Cage Motors

## Appendix

### Training

#### Training courses for drive systems

This is intended to give you an overview of the training courses offered for three-phase motors and drive systems.

Our courses are tailored to different target groups as well as to individual customer requirements.

You can select from a range of courses on the fundamentals of drive technology and on the Micromaster drive system (converter/motor).

All courses contain as many practical exercises as possible, in order to enable intensive and direct training on the drive system and with the tools in small groups.



#### The courses at a glance

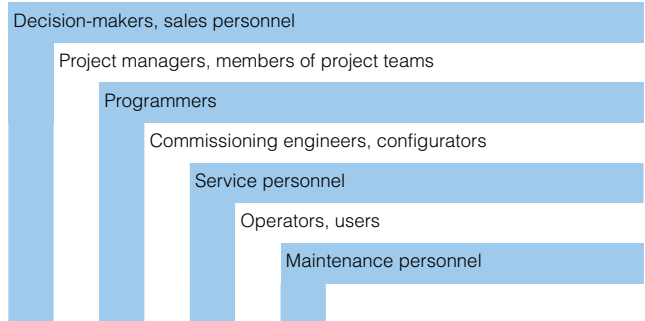

Title	Target group					Duration/ Medium	Course code
	Decision-makers, sales personnel	Project managers, members of project teams	Programmers	Commissioning engineers, configurators	Service personnel		
Motor workshop for service	✓	✓	✓	✓	✓	2 days	SD-MOT-WS
<b>MICROMASTER</b>							
MICROMASTER 4 Advanced Course, Commissioning	✓	✓	✓	✓	✓	3 days	SD-MM4-AUF
MICROMASTER MM4/G110 Compact Course	✓	✓	✓	✓	✓	1 day	SD-WSMM4
Commissioning MICROMASTER 420	✓	✓	✓	✓	✓	CD-ROM	SM-MM4
Commissioning MICROMASTER 420	✓	✓	✓	✓	✓	WBT	WT-MM4
<b>AC converters</b>							
Handling drive faults – AC drives	✓	✓	✓	✓	✓	3 days	SD-IHAC02
Fundamentals of drive technology	✓	✓	✓	✓	✓	5 days	SD-GAT

### Overview

The SD Manual Collection brings together all manuals of low-voltage motors, geared motors and low-voltage converters in the smallest possible package. It is eminently suitable for startup and service, replaces the space-consuming paper version in the office and provides fast access to the information.

- Keyword search within the PDF file
- Full text search in the complete DVD
- Electronic Update Service, free of charge for 1 year
- The DVD is networkable, i. e. storage of the PDFs is on the central server

The SD Manual Collection on DVD in 5 languages (English, French, German, Italian and Spanish) contains manuals of the following motors and converters:

- Low-voltage converters
  - IEC motors
  - NEMA motors
- Geared motors
- Low-Voltage converters
  - MICROMASTER 3
  - MICROMASTER 4
  - SINAMICS G110
  - SINAMICS G120, SINAMICS G120D
  - Frequency converters SIMATIC ET200

#### *Maintenance service for 1 year*

In addition, a maintenance service can be ordered, which includes the delivery of the up-to-date SD Manual Collection as well as the three following updates. This is valid for one year. If the contract isn't canceled, it automatically is renewed for one more year.

### Selection and ordering data

	Order No.
<b>SD Manual Collection on DVD <sup>1)</sup>, 5 languages</b>	<b>6SL3298-0CA00-0MG0</b>

all manuals for low-voltage motors, geared motors and low-voltage converters

<b>SD Manual Collection on DVD <sup>1)</sup>, 5 languages, Update service for 1 year</b>	<b>6SL3298-0CA10-0MG0</b>
--	---------------------------

<sup>1)</sup> Subject to export regulations: AL: N and ECCN: 5D992.

# IEC Squirrel-Cage Motors

## Appendix

### Siemens Contacts Worldwide



At

<http://www.siemens.com/automation/partner>

you can find details of Siemens contact partners worldwide responsible for particular technologies.

You can obtain in most cases a contact partner for

- Technical Support,
- Spare parts/repairs,
- Service,
- Training,
- Sales or
- Consultation/engineering.

You start by selecting a

- Country,
- Product or
- Sector.

By further specifying the remaining criteria you will find exactly the right contact partner with his/her respective expertise.





**Siemens Industry Automation and Drive Technologies in the WWW**

A detailed knowledge of the range of products and services available is essential when planning and configuring automation systems. It goes without saying that this information must always be fully up-to-date.

Siemens Industry Automation and Drive Technologies has therefore built up a comprehensive range of information in the World Wide Web, which offers quick and easy access to all data required.

Under the address

<http://www.siemens.com/automation>

you will find everything you need to know about products, systems and services.

**Product Selection Using the Offline Mall**

Detailed information together with convenient interactive functions:

The Offline Mall CA 01 covers more than 100,000 products and thus provides a full summary of the Siemens Automation and Drives product base.

Here you will find everything that you need to solve tasks in the fields of automation, switchgear, installation and drives. All information is linked into a user interface which is easy to work with and intuitive.

After selecting the product of your choice you can order at the press of a button, by fax or by online link.

Information on the Offline Mall CA 01 can be found in the Internet under

<http://www.siemens.com/automation/ca01>

or on DVD.

**Easy Shopping with the A&D Mall**

The A&D Mall is the virtual department store of Siemens AG in the Internet. Here you have access to a huge range of products presented in electronic catalogs in an informative and attractive way.

Data transfer via EDIFACT allows the whole procedure from selection through ordering to tracking of the order to be carried out online via the Internet.

Numerous functions are available to support you.

For example, powerful search functions make it easy to find the required products, which can be immediately checked for availability. Customer-specific discounts and preparation of quotes can be carried out online as well as order tracking and tracing.

Please visit the A&D Mall on the Internet under:

<http://www.siemens.com/automation/mall>

# IEC Squirrel-Cage Motors

## Appendix

### Customer Support

Our services for every phase of your project



In the face of harsh competition you need optimum conditions to keep ahead all the time:

a strong starting position, a sophisticated strategy and team for the necessary support – in every phase.

Service & Support from Siemens provides this support with a complete range of different services for automation and drives.

In every phase: from planning and commissioning to maintenance and upgrading.

Our specialists know when and where to act to keep the productivity and cost-effectiveness of your system running in top form.

### Online Support



The comprehensive information system available round the clock via Internet ranging from Product Support and Service & Support services to Support Tools in the Shop.

<http://www.siemens.com/automation/service&support>

### Technical Support



Competent consulting in technical questions covering a wide range of customer-oriented services for all our products and systems.

**Phone: +49 (0)180 50 50 222**

**Fax: +49 (0)180 50 50 223**

(0.14 €/min. from the German fixed network)

E-Mail: [adsupport@siemens.com](mailto:adsupport@siemens.com)

In the United States, call toll-free:

**Phone: +1 800 333 7421**

**Fax: +1 423 262 2200**

E-Mail: [solutions.support@sea.siemens.com](mailto:solutions.support@sea.siemens.com)

In Canada, call:

**Phone: +1 888 303 3353**

E-Mail: [cic@siemens.ca](mailto:cic@siemens.ca)

In Asia:

**Phone: +86 10 6475 7575**

**Fax: +86 10 6474 7474**

E-Mail:

[adsupport.asia@siemens.com](mailto:adsupport.asia@siemens.com)

### Technical Consulting

Support in the planning and designing of your project from detailed actual-state analysis, target definition and consulting on product and system questions right to the creation of the automation solution. <sup>1)</sup>

### Configuration and Software Engineering

Support in configuring and developing with customer-oriented services from actual configuration to implementation of the automation project. <sup>1)</sup>

### Service on Site



With service on site we offer services for startup and maintenance, essential for ensuring system availability.

In Germany

**Phone: +49 (0)180 50 50 444 <sup>1)</sup>**

(0.14 €/min. from the German fixed network)

In the United States, call toll-free:

**Phone: +1 800 333 7421**

In Canada, call:

**Phone: +1 888 303 3353**

### Repairs and Spare Parts



In the operating phase of a machine or automation system we provide a comprehensive repair and spare parts service ensuring the highest degree of operating safety and reliability.

In Germany

**Phone: +49 (0)180 50 50 448 <sup>1)</sup>**

(0.14 €/min. from the German fixed network)

In the United States, call toll-free:

**Phone: +1 800 241 4453**

In Canada, call:

**Phone: +1 888 303 3353**

### Optimization and Upgrading



To enhance productivity and save costs in your project we offer high-quality services in optimization and upgrading. <sup>1)</sup>

<sup>1)</sup> For country-specific telephone numbers go to our Internet site at: <http://www.siemens.com/automation/service&support>

### Knowledge Base on CD-ROM



For those applications in which an online link to the Internet is not available, an extract from the information area that can be accessed free of charge is available on CD-ROM (Service & Support Knowledge Base). This CD-ROM contains all the product information (FAQs, downloads, tips and tricks, news) that was available at the time the CD was generated as well as general information about service and technical support.

On the CD-ROM you will also find a full text search and our Knowledge Manager to search for specific solutions. The CD-ROM is updated every 4 months.

As is the case with our online information on the Internet, the Service & Support Knowledge Base CD is available complete with 5 languages (English, German, French, Italian and Spanish).

You can order the CD **Service and Support Knowledge Base** from your Siemens contact.

Order No.: **6ZB5310-0EP30-0BA2**

Ordering via the Internet  
(with the Automation Value Card or credit card) at:

<http://www.siemens.com/automation/service&support>  
in the shop.

### Automation Value Card



#### Small card – lots of support

The Automation Value Card is an integral part of the comprehensive service concept with which Siemens Automation and Drives accompanies you in every phase of your automation project.

Whether you require certain services from our Technical Support or want to buy high-quality support tools in our online shop: You can always pay with the Automation Value Card. No costs for processing invoices, transparent and secure. With the card number that is only known to you and the associated PIN, you can check your current balance at any time as well as all the debits and credits.

Services on the card. This is how it works.

The card number and PIN are printed on the back of the Automation Value Card. When it is supplied, the PIN is covered by a scratch field so the full credit is guaranteed to be on the card.

By specifying the card number and PIN, you have complete access to the current range of Service and Support. The amount for the service obtained is deducted in the form of credits from the balance on your Automation Value Card.

All the offered services are priced in terms of credits independently of national currencies, so you can use the Automation Value Card worldwide.

#### Order Numbers for the Automation Value Card

Credits	Order No.
200	<b>6ES7 997-0BA00-0XA0</b>
500	<b>6ES7 997-0BB00-0XA0</b>
1000	<b>6ES7 997-0BC00-0XA0</b>
10000	<b>6ES7 997-0BG00-0XA0</b>

For detailed information about the offered services, visit our Internet site:

<http://www.siemens.com/automation/service&support>

Service & Support à la Card: Some examples

#### Technical Support

"Priority"	Priority handling for urgent cases
"24 h"	Availability round-the-clock
"Extended"	Technical advice for complex questions

#### Support tools in the Support Shop

"System Utilities"	Ready-to-use tools for design, analysis and checking
"Applications"	Complete topics including fully tested software
"Functions & Samples"	Modifiable function blocks to speed up your developments

# IEC Squirrel-Cage Motors

## Appendix

### Subject index

	Part 0	Part 1	Part 2	Part 3	Part 4	Part 5	Part 6	Part 7	Part 8	Part 9	Part 10	Part 11
	Page 0/	Page 1/	Page 2/	Page 3/	Page 4/	Page 5/	Page 6/	Page 7/	Page 8/	Page 9/	Page 10/	Page 11/
<b>A</b>												
A&D in the WWW												21
Acceptance											10 ... 24	
Acceptance test certificate											5	
<b>Accessories</b>		64	120	62	125	32	4	53	4	42	25	
Admissible loading on the shaft extension – Admissible cantilever forces	66 ..., 125 ...									5		
Appendix												1 ...
<b>Application</b>		4	4	3	3	2	2	2	2	3	3	
Area subject to explosion hazard					13							
Automation Value Card												23
<b>B</b>												
Balance	56, 120	58, 62	81, 86, 89, 96, 102, 109, 114, 118	52, 56, 60	94, 98, 102, 107, 112, 118, 122	25, 30		37, 42, 47, 51		35, 37, 39, 41		
Basic marine version											10 ... 24	
Bearing currents						8						
Bearing plates	36									4		
Bearing selection table	60 ..., 124											
Bearings	58, 122	58, 62	81, 86, 89, 96, 102, 109, 113, 118	5, 52, 56, 60	94, 97, 102, 107, 112, 118, 122	8, 18, 25, 30		30, 37, 42, 47, 51		5, 35, 37, 39, 41		
<b>Benefits</b>		3	4	2	3	2	2	2	2	3	3	
Bimetal switches	34, 110											
Brakes	77 ..., 130 ...											
Bureau Veritas											2	
<b>C</b>												
Cantilever forces	66 ..., 125 ...											
CCC	16, 99											
CEMEP	15, 98	2	2				2	2	2			
Certification											10 ... 24	
Classification of explosion-protected equipment					15							
Colors	17, 100	56, 61	79, 85, 89, 94, 100, 107, 113, 117	51, 55, 59	93, 97, 101, 106, 111, 117, 121	23, 28		35, 40, 46, 50		5, 34, 36, 38, 40	5	
COMBIMASTER 411/ MICROMASTER 411			5			3						8
Combination of basic versions	84											
Compressor motors									1 ...			
Conditions of delivery												46
Configuration												22
Connection box	38 ..., 113 ...	55, 60	78, 84, 88, 92, 99, 105, 112, 116	50, 54, 58	93, 96, 100, 105, 111, 116, 121	22, 27		34, 39, 45, 49		34, 36, 38, 40		
Contact Partner Worldwide												20
Converted-fed operation			7	5	82	2					5	
Converter mounting						19						
Coolant temperature	31, 107	4, 57, 61	7, 81, 86, 89, 96, 102, 109, 113, 118	4, 51, 55, 59	5, 94, 97, 107, 112, 118, 122	24, 30		37, 42, 47, 51		4	5	
Couplings		64	121	62	125	32		53		42		
CSA	16, 99		3									
Currents	22, 103	5 ...	8 ...	11 ...	11 ..., 18 ...	9, 12 ...		4 ...		7 ...		
Customer Support												22
Customized motors												9
Cut-way diagram of a low voltage motor	13, 97											

# IEC Squirrel-Cage Motors

## Appendix

### Subject index

	Part 0 Page 0/	Part 1 Page 1/	Part 2 Page 2/	Part 3 Page 3/	Part 4 Page 4/	Part 5 Page 5/	Part 6 Page 6/	Part 7 Page 7/	Part 8 Page 8/	Part 9 Page 9/	Part 10 Page 10/	Part 11 Page 11/
<b>D</b>												
Degree of protection	54, 118	57, 61	81, 85, 89, 95, 102, 108, 113, 118	51, 55, 59	94, 97, 102, 106, 112, 117, 122	24, 29		36, 42, 46, 51		34, 36, 38, 40	5, 6 ...	
Design				3								
Design for Zones 2 and 22 according to ATEX				56, 60								
Design for Zones 2, 21 and 22 according to ATEX					93, 96, 100, 104, 110, 115, 120							
Designs in accordance with standards and specifications	14, 98	57, 62	81, 86, 89, 96, 102, 109, 113, 118	51, 56, 60	94, 97, 102, 107, 112, 118, 122	25		37, 42, 47, 51				
Det Norske Veritas											2	
Device groups					16							
Diagrams of bearings	64, 65, 124											
<b>Dimension drawings</b>		68 ...	124 ...	64 ...	130 ...	34		56				
Dimension sheet generator		67	123		129	40		65				
<b>Dimensions</b>		65 ...	122 ...	63 ...	127 ...	33 ...	4	55 ...	4	43 ...	25	
Direction of rotation	29, 105											
Distributed drive solutions			5			3						7
Documentation	20, 102	59, 63	87, 90, 97, 103, 119	52, 56, 60	95, 98, 103, 108, 113, 119, 123	26, 31		38, 43, 48, 52				19
Drainage holes										4		
Dual-function motors										3		
Duty type										4		
<b>E</b>												
Earth brushes for converter-fed operation						19						
Easy Shopping with the A&D Mail												21
ECOFAST	51		5			4, 19						
EFF1		2	2				2, 3	2, 3	2, 3			
EFF2		2	2				3	3	3			
EFF3		2	2									
Efficiency and efficiency requirements according to EPACT		2	3									
Encoder mounting		64	121		6	32						
Energy-saving motors		2	2									
Energy-saving program SinaSave												13
EPACT	15, 98	2	3				2	2	2			
Explosion group					17							
Explosion limits					13							
Explosion-proof enclosure					3, 16, 82							
Explosion-proof motors	14				1 ...						7, 9, 13 ... 16, 24	
Export regulations												46
Extra rating plates	30, 106	58, 63	82, 86, 90, 97, 103, 110, 114, 119	52, 56, 60	95, 98, 103, 108, 113, 118, 123	25, 31		37, 43, 47, 52		35, 37, 39, 41		
<b>F</b>												
Fan	36, 111											
Fan motors	25							1 ...				
Feeders	38, 113											
Fixing bolts			120	62	125	32		53		42		
Flange dimensions		76	140	70	152	40		64				
Flash point					13							
Foundation blocks			120	62	125	32		53		42		
Frame design											3	
Frequencies	22, 103											

# IEC Squirrel-Cage Motors

## Appendix

### Subject index

	Part 0 Page 0/	Part 1 Page 1/	Part 2 Page 2/	Part 3 Page 3/	Part 4 Page 4/	Part 5 Page 5/	Part 6 Page 6/	Part 7 Page 7/	Part 8 Page 8/	Part 9 Page 9/	Part 10 Page 10/	Part 11 Page 11/
<b>F (continue)</b>												
Frequency										4		
Frequency converters												2
Frequency converters for distributed I/O												2
Fundamental physical principles and definitions					13							
<b>G</b>												
General technical data	13, 97											
Germanischer Lloyd											2	
Grease										5		
Grease lifetime	58, 122		7	5		5						
Guide to selecting and ordering the motors	2											
<b>H</b>												
Heating	36, 111	58, 62	82, 86, 90, 96, 103, 109, 114, 118	52, 56, 60	95, 98, 102, 107, 113, 118, 123	25, 30		37, 43, 47, 52		35, 37, 39, 41		
High efficiency		2	2, 3									
<b>I</b>												
IEC motors			2									
Implementation in areas subject to explosion hazards						5						
Improved efficiency		2	3									
Increased safety					3							
Index of order numbers												30
Individual acceptance											2	
Insulation	32, 108	4, 55, 60	7, 79, 84, 88, 93, 100, 106, 112, 117	4, 5, 50, 55, 59	93, 96, 101, 105, 111, 116, 121	5, 18, 22, 28		34, 40, 45, 50				
Insulation system										4		
Integrated explosion protection					13							
<b>Integration</b>			5			3						
Internet												21
<b>K</b>												
Knowledge Base on CD-ROM												23
KTY 84 temperature sensor	35, 110	21 ... 53		46		18						
<b>L</b>												
Legislative basis					14							
Lloyds Register											2	
Loading on the shaft extension										5		
Low-voltage motor	13, 97											
Lubrication	58, 59, 122, 123	58, 62	81, 86, 89, 96, 102, 109, 113, 118	52, 56, 60	94, 97, 102, 107, 112, 118, 122	25, 30		37, 42, 47, 51		35, 37, 39, 41		
<b>M</b>												
Mains-fed operation					81							
Marine motors											1 ...	
Axial load	71 ..., 126 ...											
Mechanical design	54, 118	57, 61	81, 85, 89, 95, 102, 108, 113, 118	51, 55, 59	94, 97, 102, 106, 112, 117, 122	24, 29		36, 42, 46, 51		34, 36, 38, 40		
Mechanical limit speeds			7			5, 6						
Mechanical stress			7	5		5						
Metal surcharges												44
MICROMASTER 410/420/430/440												8
MICROMASTER 411/ COMBIMASTER 411			5			3						8
Minimum cooling air flow										5		
Minimum efficiencies	15, 98											
Minimum ignition energy					14							
Modular technology	75, 127	56	80, 94, 95, 101, 107, 108			23, 24, 28		36, 41				

# IEC Squirrel-Cage Motors

## Appendix

### Subject index

	Part 0 Page 0/	Part 1 Page 1/	Part 2 Page 2/	Part 3 Page 3/	Part 4 Page 4/	Part 5 Page 5/	Part 6 Page 6/	Part 7 Page 7/	Part 8 Page 8/	Part 9 Page 9/	Part 10 Page 10/	Part 11 Page 11/
<b>M (continue)</b>												
<b>More information</b>		7	9	13	13	9	2	5	2	7	5	
Motor connection	38, 113	55, 60	78, 84, 88, 92, 99, 105, 112, 116	5, 50, 54, 58	93, 96, 100, 105, 111, 116, 121	5, 22, 27		34, 39, 45, 49		34, 36, 38, 40	3	
Motor protection	34, 110	8 ... 53	78, 84, 88, 92, 99, 105, 112, 116	5, 46, 50, 54, 58	93, 96, 100, 104, 110, 115, 120	5, 18, 22, 27		34, 39, 45, 49		34, 36, 38, 40	5	
Motors operating with frequency converters						1 ...						
<b>N</b>												
N compact				2								
NEMA	15, 99											
NEMA motors			2									10
Noise generation			7	5		5, 18						
Non-standard motors	24, 37			1 ...							9, 23	
Number of poles										4		
<b>O</b>												
Online Services												21
Online Support												22
Optimization												22
Options		55 ...	78 ...	50 ...	93 ...	22		34 ...		34 ...		
Order code	8 ..., 95 ...											
Order information											10	
Order No. supplements		20 ... 53	10 ... 65	14 ... 44	18 ... 79	12, 16		6 ... 29		9 ... 31		
Order No. code	7, 94											
Ordering in the Internet and on DVD												21
<b>Orientation</b>		2	2	2	2	2	2	2	2	2	2	
Outputs	28, 105											
Overall dimensions		65	122	63	127	33		55		43		
<b>Overview</b>	2, 7, 8, 13, 94, 95, 97	2	2	2	2	2	2	2	2	2	2	
Overview of products												2
<b>P</b>												
Packaging	20, 102	59, 63	82, 87, 90, 97, 103, 110, 114, 119	52, 56, 60	95, 98, 103, 108, 113, 119, 123	26, 31		38, 43, 48, 52		35, 37, 39, 41		
Paint finish	17, 100	56, 61	79, 85, 89, 94, 100, 107, 113, 117	51, 55, 59	93, 97, 101, 106, 111, 117, 121	23, 28		35, 40, 46, 50		5, 34, 36, 38, 40	5, 6	
Power factor	29, 105	8 ...	10 ...	10 ...	18 ...	12 ...		6 ...		8 ...		
Preliminary selection of the motor		5, 6	8, 9	11, 12	11, 12	9		4, 5		7		
Primary explosion protection					13							
Product Selection Using the Offline Mall												21
Protection against dust explosions in Zones 21 and 22					4							
PT100 resistance thermometers				46								
PTC thermistors	34, 110											
Pump motors							1 ...					
Pump version from stock							3, 4					
<b>R</b>												
RAL	18 ..., 101 ...											
Rated output		5 ...	7 ...	4 ...	11 ...	9 ...		4 ...		4, 7 ...		
Rated speed	29, 105	5 ...	7 ...	4 ...	11 ...	9 ...		4 ...		7 ...		
Rated torque	29, 105	5 ...	7 ...	4 ...	11 ...	9 ...		4 ...		7 ...		
Rated voltage		20 ...	10 ...	5, 14 ...	18 ...	5, 12 ...		6 ...		8 ...		

# IEC Squirrel-Cage Motors

## Appendix

### Subject index

	Part 0	Part 1	Part 2	Part 3	Part 4	Part 5	Part 6	Part 7	Part 8	Part 9	Part 10	Part 11
	Page 0/	Page 1/	Page 2/	Page 3/	Page 4/	Page 5/	Page 6/	Page 7/	Page 8/	Page 9/	Page 10/	Page 11/
<b>R (continue)</b>												
Rating plate	30, 106	58, 63	3, 82, 86, 90, 97, 103, 110, 114, 119	5, 52, 56, 60	95, 98, 103, 108, 113, 118, 123	18, 25, 31		37, 43, 47, 52		35, 37, 39, 41	5	
Rating plate data for motors operating with frequency converters						18						
Recommended special versions for mains-fed and converted-fed operations							3		4			
Repair parts		64	121	62	126	32		54		42		
Repairs - contact partner												22
Rotary pulse encoder	75 ..., 127 ...				5 ... 7							
Rotary pulse encoder 1XP8 001	75											
Rotary pulse encoder 1XP8 012	127, 128											
Rotor	56, 121	58, 62	82, 86, 90, 96, 103, 109, 114, 118	52, 56, 60	94, 98, 102, 107, 113, 118, 122	25, 30		37, 42, 47, 51				
<b>S</b>												
Safety notes	20, 102	59, 63	82, 87, 90, 97, 103, 110, 114, 119	52, 56, 60	95, 98, 103, 108, 113, 119, 123	26, 31		38, 43, 48, 52		35, 37, 39, 41		
SD configurator		67	123		129	40		65				11
Secondary explosion protection					13							
<b>Selection and ordering data</b>		5, 8 ...	8, 10 ...	11, 14 ...	11, 18 ...	9, 10 ...	3, 4	4, 6 ...	3	7, 8 ...	6 ...	
Separately driven fan	76, 129											
Service on Site												22
Shaft	56, 121	58, 62	82, 86, 90, 96, 103, 109, 114, 118	52, 56, 60	94, 98, 102, 107, 113, 118, 122	25, 30		37, 42, 47, 51				
Siemens Contacts Worldwilde												20
Siemens Industry Automation and Drive Technologies in the WWW												21
SIMATIC ET 200S FC												2
SINAMICS G110												4
SINAMICS G110 chassis inverter												4
SINAMICS G120												5
SINAMICS G120D												6
SinaSave												13
Site altitude	31, 107	57, 61	81, 86, 89, 96, 102, 109, 113, 118	51, 55, 59	5, 94, 97, 107, 112, 118, 122	24, 30		37, 42, 47, 51		4		
SITRAIN												17
SIZER												14
Slide rails			120	62	125	32		53		42		
Smoke-extraction motors										1 ...		
Software Engineering												22
Spare motors		64	121	62	126	32		54		42		
Special finish	18, 101											
Special insulation up to 690 V				11 ...		5, 9, 12 ...						
Special technology	85, 134	57	80, 95, 101, 108	51, 55, 59		24, 29		36, 41				
<b>Special versions</b>	8 ..., 95 ...	54 ...	66 ...	46 ...	81 ...	18 ...	3	30 ...	4	32 ...	10 ...	
Specifications	14, 98	57, 62	81, 86, 89, 96, 102, 109, 113, 118	51, 56, 60	94, 97, 102, 107, 112, 118, 122	25		37, 42, 47, 51				
SPM shock pulse measurement	58, 122											
Standard motors	23, 37		1 ...								6, 8, 10 ...	
<i>Standardline</i>				13, 50, 54, 58								
Standards and specifications	14, 98									4	2	
Supervision of construction												2
Supply frequencies						18						



# IEC Squirrel-Cage Motors

## Appendix

### Subject index

	Part 0 Page 0/	Part 1 Page 1/	Part 2 Page 2/	Part 3 Page 3/	Part 4 Page 4/	Part 5 Page 5/	Part 6 Page 6/	Part 7 Page 7/	Part 8 Page 8/	Part 9 Page 9/	Part 10 Page 10/	Part 11 Page 11/
<b>T</b>												
Taper pins			121	62	125	32		53		42		
Technical Consulting												22
<b>Technical specifications</b>	13, 97	4	7	4 ...	3 ...	5 ...		3		4	3	
Technical Support												22
Technology	75, 127	56, 57	80, 94, 101, 107	51, 55, 59	5, 101, 106, 112, 117, 122	23, 29		36, 41				
Temperature class											5	
Temperature classes					17							
Temperature detectors	34, 110											
Temperature sensor KTY 84	35, 110	21 ... 53		46		18						
Temperature/time classes										2, 7	8	
Tensioning screws			120	62	125	32		53		42		
Terminal connection	49, 115											
Termination system										4		
Terms and Conditions of Sale and Delivery												46
Test certificates	20, 102	59, 63	82, 87, 90, 97, 103, 110, 114, 119	52, 56, 60	95, 98, 103, 108, 113, 119, 123	26, 31		38, 43, 48, 52		2, 35, 37, 39, 41		
Thermal torque limits				6								
Torque limits				6								
Training												17
Training courses at a glance												18
Training courses for drive systems												18
Type approved explosion-proof motors up to frame size 315 L in marine version											13 ...	
Type approved fan motors in marine version											17 ...	
Type approved standard motors up to frame size 315 L in marine motors											10 ...	
Type test											2	
Type test certificate											4	
Types of construction	52, 116	20 ...	76 ...	3, 10 ...	90 ...	21		33		33		
Types of protection					16							
<b>U</b>												
UL approval	15, 99											
Upgrading												22
<b>V</b>												
Ventilation	36, 111	58, 62	7, 82, 86, 90, 96, 103, 109, 114, 118	5, 52, 56, 60	95, 98, 102, 107, 113, 118, 123	5, 18, 25, 30		37, 43, 47, 52		35, 37, 39, 41		
Vibration quantity	56, 120	58, 62	81, 86, 89, 96, 102, 109, 114, 118	52, 56, 60	94, 98, 102, 107, 112, 118, 122	25, 30		37, 42, 47, 51		35, 37, 39, 41		
VIK version					83							
Voltage	22, 103	54	67 ...	47 ...	84 ...	20		30 ...		4, 32		
<b>W</b>												
Windings and insulation	32, 108	55, 60	79, 84, 88, 93, 100, 106, 112, 117	50, 55, 59	93, 96, 101, 105, 111, 116, 121	22, 28		34, 40, 45, 50				
<b>Z</b>												
Zone 1 with type of protection Ex de IIC explosion-proof enclosure "d"					3							
Zone 1 with type of protection Ex e II Increased Safety "e"					3							
Zone 2 with type of protection EX nA (non sparking)					4							
Zones					16							

# IEC Squirrel-Cage Motors

## Appendix

### Index of order numbers

Order No.	Part 1 Page 1/	Part 2 Page 2/	Part 3 Page 3/	Part 4 Page 4/	Part 5 Page 5/	Part 6 Page 6/	Part 7 Page 7/	Part 8 Page 8/	Part 9 Page 9/	Part 10 Page 10/
<b>1LA5</b>										
1LA5 18 ...		10 ... 21		42 ... 49	10 ... 13	3	8 ... 13		8 ... 13	6, 7, 8
1LA5 20 ...		10 ... 21		42 ... 49	10 ... 13	3	8 ... 13		8 ... 13	6, 7, 8
1LA5 22 ...		10 ... 17		42 ... 49	10 ... 13	3			8 ... 11	6, 7, 8
<b>1LA6</b>										
1LA6 1 ...		38 ... 45		62 ... 69	10, 11	3			20 ... 25	6, 7, 8
<b>1LA7</b>										
1LA7 05 ...		10 ... 13		42 ... 45	10, 11	3				6, 7
1LA7 06 ...		10 ... 19		42 ... 45	10, 11	3				6, 7
1LA7 07 ...		10 ... 19		42 ... 49	10, 11	3				6, 7
1LA7 08 ...		10 ... 19		42 ... 49	10, 11	3	6 ... 11		8 ... 12	6, 7
1LA7 09 ...		10 ... 21		42 ... 49	10, 11	3	6 ... 13		8 ... 12	6, 7
1LA7 1 ...		10 ... 21		42 ... 49	10 ... 13	3	6 ... 13		8 ... 12	6, 7
<b>1LA8</b>										
1LA8 ...			14 ... 25	78	10, 11, 17	3		3		9
<b>1LA9</b>										
1LA9 05 ...		22 ... 37		50 ... 53, 56 ... 59	10, 11	3		3		6, 7
1LA9 06 ...		22 ... 37		50 ... 53, 56 ... 59	10, 11	3		3		6, 7
1LA9 07 ...		22 ... 37		50 ... 53, 56 ... 59	10, 11	3		3		6, 7
1LA9 08 ...		22 ... 37		50 ... 53, 56 ... 59	10, 11	3		3		6, 7
1LA9 09 ...		22 ... 37		50 ... 61	10, 11	3		3		6, 7
1LA9 1 ...		22 ... 37		50 ... 61	10, 11	3		3		6, 7
1LA9 20 ...		22 ... 37		50 ... 61	10, 11	3		3		6, 7
<b>1LE1</b>										
1LE1 001 ...	22 ... 27, 34, 42					3		3		
1LE1 002 ...	8 ... 19, 30, 38					3		3		
<b>1LG4</b>										
1LG4 18 ...		38 ... 47		62 ... 69	10, 11	3	14 ... 19	3		6, 7
1LG4 20 ...		38 ... 47		62 ... 69	10, 11	3	14 ... 19	3		6, 7
1LG4 22 ...		38 ... 47		62 ... 69	10, 11	3	14 ... 19	3		6, 7
1LG4 25 ...		38 ... 47		62 ... 69	10, 11	3	14 ... 19	3		6, 7
1LG4 28 ...		38 ... 47		62 ... 69	10, 11	3	14 ... 19	3		6, 7
1LG4 310 ...		38 ... 45		62 ... 69	10, 11	3	14 ... 19	3		6, 7
1LG4 313 ...		38 ... 45		62 ... 69	10, 11	3	14 ... 19	3		6, 7
1LG4 316 ...		38 ... 45		62 ... 69	10, 11	3	14 ... 19	3		6, 7
1LG4 317 ...		38 ... 45		62 ... 69	10, 11	3	14 ... 19	3		6, 7
1LG4 318 ...		42 ... 45		66 ... 69	10, 11	3		3		6, 7
<b>1LG6</b>										
1LG6 18 ...		48 ... 57		70 ... 79	10, 11, 14 ... 16				20 ... 23	6, 7
1LG6 20 ...		48 ... 57		70 ... 79	10, 11, 14 ... 16				20 ... 23	6, 7
1LG6 22 ...		48 ... 57		70 ... 79	10, 11, 14 ... 16				20 ... 23	6, 7
1LG6 25 ...		48 ... 57		70 ... 79	10, 11, 14 ... 16				8 ... 11, 20 ... 23	6, 7
1LG6 28 ...		48 ... 57		70 ... 79	10, 11, 14 ... 16				8 ... 11, 20 ... 23	6, 7
1LG6 310 ...		48 ... 57		70 ... 79	10, 11, 14 ... 16				8 ... 11, 20 ... 23	6, 7
1LG6 313 ...		48 ... 57		70 ... 79	10, 11, 14 ... 16				8 ... 11, 20 ... 23	6, 7
1LG6 316 ...		48 ... 57		70 ... 79	10, 11, 14 ... 16				8 ... 11, 20 ... 23	6, 7
1LG6 317 ...		48 ... 57		70 ... 79	10, 11, 14 ... 16				8 ... 11, 20 ... 23	6, 7
1LG6 318 ...		50 ... 57		72 ... 79	10, 11, 14 ... 16				10, 11, 22, 23	6, 7

# IEC Squirrel-Cage Motors

## Appendix

### Index of order numbers

Order No.	Part 1 Page 1/	Part 2 Page 2/	Part 3 Page 3/	Part 4 Page 4/	Part 5 Page 5/	Part 6 Page 6/	Part 7 Page 7/	Part 8 Page 8/	Part 9 Page 9/	Part 10 Page 10/
<b>1LH8</b>										
1LH8 45 ...										9
<b>1LL8</b>										
1LL8 ...			34 ... 45		10					9
<b>1LP4</b>										
1LP4 18 ...		62 ... 65			10					8
1LP4 20 ...		62 ... 65			10					8
1LP4 22 ...		62 ... 65			10					8
1LP4 25 ...		62 ... 65			10					8
1LP4 28 ...		62 ... 65			10					8
1LP4 3 ...		62 ... 65			10					8
<b>1LP5</b>										
1LP5 ...		58 ... 61			10					8
<b>1LP7</b>										
1LP7 ...		58 ... 61			10					8
<b>1MA6</b>										
1MA6 10 ...				22, 26, 30						7
1MA6 11 ...				22, 26, 30						7
1MA6 13 ...				22 ... 27						7
1MA6 16 ...				22 ... 27						7
1MA6 18 ...				22 ... 31						7
1MA6 20 ...				22 ... 31						7
1MA6 22 ...				22, 26 ... 31						7
1MA6 25 ...				22, 26 ... 31						7
1MA6 28 ...				22, 26 ... 33						7
1MA6 310 ...				22, 26 ... 33						7
1MA6 313 ...				22, 26 ... 33						7
1MA6 316 ...				22, 26 ... 33						7
1MA6 317 ...				22, 26 ... 33						7
1MA6 318 ...				30 ... 33						7
<b>1MA7</b>										
1MA7 ...				18 ... 21						7
<b>1MJ6</b>										
1MJ6 ...				34 ... 41	11					7
<b>1MJ7</b>										
1MJ7 ...				34 ... 41	11					7
<b>1PC1</b>										
1PC1 001	50									
1PC1 002	46									
<b>1PP4</b>										
1PP4 18 ...					11		24 ... 29			7
1PP4 2 ...					11		24 ... 29			7
1PP4 310 ...					11		24 ... 27			7
1PP4 313 ...					11		24 ... 27			7
1PP4 316 ...					11		24 ... 27			7
1PP4 317 ...					11		24 ... 27			7
1PP4 318 ...					11		28 ... 29			7
<b>1PP5</b>										
1PP5 18 ...					11		20 ... 23		14 ... 19	7
1PP5 20 ...					11		20 ... 23		14 ... 19	7
1PP5 22 ...									14 ... 17	7

# IEC Squirrel-Cage Motors

## Appendix

### Index of order numbers

Order No.	Part 1 Page 1/	Part 2 Page 2/	Part 3 Page 3/	Part 4 Page 4/	Part 5 Page 5/	Part 6 Page 6/	Part 7 Page 7/	Part 8 Page 8/	Part 9 Page 9/	Part 10 Page 10/
<b>1PP6</b>										
1PP6 10 ...									26 ... 31	
1PP6 11 ...									26 ... 31	
1PP6 13 ...									26 ... 31	
1PP6 16 ...									26 ... 31	
1PP6 18 ...									26 ... 29	
1PP6 20 ...									26 ... 29	
1PP6 22 ...									26 ... 29	
1PP6 25 ...									14 ... 17, 26 ... 29	
1PP6 28 ...									14 ... 17, 26 ... 29	
1PP6 310 ...									14 ... 17, 26 ... 29	
1PP6 313 ...									14 ... 17, 26 ... 29	
1PP6 316 ...									14 ... 17, 26 ... 29	
1PP6 317 ...									14 ... 17, 26 ... 29	
1PP6 318 ...									16, 17, 28, 29	
<b>1PP7</b>										
1PP7 06 ...					11		20 ... 21			7
1PP7 07 ...					11		20 ... 23			7
1PP7 08 ...					11		20 ... 23		14 ... 19	7
1PP7 09 ...					11		20 ... 23		14 ... 19	7
1PP7 1 ...					11		20 ... 23		14 ... 19	7
<b>1PP9</b>										
1PP9 ...		120								
<b>1PQ8</b>										
1PQ8 ...			26 ... 33	80	10, 11, 17					9
<b>1XP8</b>										
1XP8 001 ...		120								
<b>2CW2</b>										
2CW2 ...		120								

# IEC Squirrel-Cage Motors

## Appendix

Overview of order codes  
1LA, 1LG, 1LL, 1LP, 1MA, 1MJ, 1PP, 1PQ

### Order codes for 1LA, 1LG, 1LL, 1LP, 1MA, 1MJ, 1PP and 1PQ motors

All options are alphanumerically listed according to order codes in the following table.

A list of all available options according to categories can be found in catalog part 0 under "Introduction motors 1LA, 1LG, 1LL, 1LP, 1MA, 1MJ, 1PP, 1PQ", "Special versions".

Order codes	Special versions	Category	For further information, see Page
<b>A10</b>	With PTC thermistors for alarm for converter-fed operation in Zones 2, 21, 22	Motor protection	0/35, 4/82
<b>A11</b>	Motor protection through PTC thermistor with 3 embedded temperature sensors for tripping		0/34, 0/38
<b>A12</b>	Motor protection through PTC thermistor with 6 embedded temperature sensors for tripping and alarm		0/35
<b>A15</b>	Motor protection with PTC thermistors for converter-fed operation with 3 or 4 embedded temperature sensors for		0/35, 4/3, 4/82
<b>A16</b>	Motor protection with PTC thermistors for converter-fed operation with 6 or 8 embedded temperature sensors for		0/35, 4/3, 4/82
<b>A23</b>	Motor temperature detection with embedded temperature sensor KTY 84-130		0/35
<b>A25</b>	Motor temperature detection with embedded temperature sensors 2 x KTY 84-130		0/35
<b>A31</b>	Temperature detectors for tripping		0/34
<b>A60</b>	Installation of 3 PT 100 resistance thermometers in stator winding		0/36
<b>A61</b>	Installation of 6 PT 100 resistance thermometers in stator winding		0/36
<b>A72</b>	Installation of 2 PT 100 screw-in resistance thermometers (basic circuit) for rolling-contact bearings	0/36	
<b>A78</b>	Installation of 2 PT 100 screw-in resistance thermometers (3-wire circuit) for rolling-contact bearings	0/36	
<b>A80</b>	Installation of 2 PT 100 double screw-in resistance thermometers (3-wire circuit) for rolling-contact bearings	0/36	
<b>B00</b>	Without safety and commissioning note. Customer's declaration of renouncement required.	Packaging, safety notes, documentation and test certificates	0/21
<b>B01</b>	Complete with one set of safety and commissioning notes per wire-lattice pallet		0/21
<b>B02</b>	Acceptance test certificate 3.1 according to EN 10204		0/21
<b>B06</b>	Second lubricating plate, supplied loose	Rating plate and extra rating plates	0/30
<b>B20</b>	Standardline version	Standardline (only for motor series 1LA8)	3/13
<b>B23</b>	Operating instructions German/English enclosed in print	Packaging, safety notes, documentation and test certificates	0/21
<b>B31</b>	Document – Electrical data sheet		0/21, 3/52 ...
<b>B32</b>	Document – Order dimension drawing		0/21, 3/52 ...
<b>B37</b>	Document – Load characteristics		0/21, 3/52 ...
<b>C00</b>	Brake supply voltage 24 V DC	Modular technology - Additional versions	0/83
<b>C01</b>	Brake supply voltage 400 V AC		0/83
<b>C02</b>	Brake supply voltage 180 V DC, for operation on MM411-ECOFAST		0/83
<b>C11</b>	Temperature class 155 (F), used acc. to 155 (F), with service factor (SF)	Windings and insulation	0/32
<b>C12</b>	Temperature class 155 (F), used acc. to 155 (F), with increased power rating		0/32
<b>C13</b>	Temperature class 155 (F), used acc. to 155 (F), with increased coolant temperature		0/33
<b>C18</b>	Temperature class 180 (H) at rated output and max. CT 60 °C		0/33
<b>C19</b>	Increased air humidity/temperature with 30 to 60 g water per m <sup>3</sup> of air		0/33
<b>C22</b>	Temperature class 155 (F), used acc. to 130 (B), coolant temperature 45 °C, derating approx. 4 %		0/33
<b>C23</b>	Temperature class 155 (F), used acc. to 130 (B), coolant temperature 50 °C, derating approx. 8 %		0/33
<b>C24</b>	Temperature class 155 (F), used acc. to 130 (B), coolant temperature 55 °C, derating approx. 13 %		0/33
<b>C25</b>	Temperature class 155 (F), used acc. to 130 (B), coolant temperature 60 °C, derating approx. 18 %		0/33
<b>C26</b>	Increased air humidity/temperature with 60 to 100 g water per m <sup>3</sup> of air		0/33
<b>C27</b>	Stamping of Ex nA II on VIK rating plate	Design for Zones 1, 2, 21 and 22 according to ATEX	4/83
<b>C30</b>	Outputs T1/T2 on rating plate		4/81
<b>D01</b>	CCC China Compulsory Certification	Designs in accordance with standards and specifications	0/16
<b>D02</b>	Coolant temperature –50 to +40 °C	Coolant temperature and site altitude	0/32
<b>D03</b>	Coolant temperature –40 to +40 °C		0/32
<b>D04</b>	Coolant temperature –30 to +40 °C		0/32
<b>D11</b>	Coolant temperature 45 °C, derating 4 %		0/32
<b>D12</b>	Coolant temperature 50 °C, derating 8 %		0/32
<b>D13</b>	Coolant temperature 55 °C, derating 13 %		0/32
<b>D14</b>	Coolant temperature 60 °C, derating 18 %		0/32
<b>D19</b>	Coolant temperature –40 °C to + 40 °C for EX motor		4/5

# IEC Squirrel-Cage Motors

## Appendix

### Overview of order codes 1LA, 1LG, 1LL, 1LP, 1MA, 1MJ, 1PP, 1PQ

Order codes	Special versions	Category	For further information, see Page
<b>D30</b>	Electrical according to NEMA MG1-12	Designs in accordance with standards and specifications	0/15
<b>D31</b>	Design according to UL with "Recognition Mark"		0/15
<b>D32</b>	Ex certification for China		4/83
<b>D33</b>	Certified for Korea according to KS C4202		0/16
<b>D40</b>	Canadian regulations (CSA)		0/15, 0/16
<b>D46</b>	PSE Mark Japan		0/16
<b>E00</b>	Without type test certificate according to ABS 50 °C/CCS 45 °C/RINA 45 °C, temperature class 155 (F), used according to 155 (F)	Marine version – Basic marine version	10/4 ...
<b>E09</b>	Individual acceptance by marine classification society with supervision of construction and acceptance test certificate 3.2 according to EN 10204	Marine version – Acceptance/certification	10/4 ...
<b>E10</b>	Individual acceptance by marine classification society		10/4 ...
<b>E11</b>	With/without type test certificate according to GL (Germanischer Lloyd), Germany, CT 45 °C, temperature class 155 (F), used according to 155 (F)	Marine version – Basic marine version	10/4 ...
<b>E21</b>	With/without type test certificate according to LR (Lloyds Register), Great Britain, CT 45 °C, temperature class 155 (F), used according to 155 (F)		10/4 ...
<b>E31</b>	With/without type test certificate according to BV (Bureau Veritas), France, CT 45 °C, temperature class 155 (F), used according to 155 (F)		10/4 ...
<b>E51</b>	With/without type test certificate according to DNV (Det Norske Veritas), Norway, CT 45 °C, temperature class 155 (F), used according to 155 (F)		10/4 ...
<b>E61</b>	With/without type test certificate according to ABS (American Bureau of Shipping), USA, CT 50 °C, temperature class 155 (F), used according to 155 (F)		10/4 ...
<b>E71</b>	With/without type test certificate according to CCS (Chinese Classification Society), China, CT 45 °C, temperature class 155 (F), used according to 155 (F)		10/4 ...
<b>E80</b>	Motor for use in shipping, higher ambient temperature and/or used as 155 (F) according to 130 (B)		10/10 ...
<b>F01</b>	Standard test (routine test) with acceptance	Packaging, safety notes, documentation and test certificates	0/21, 3/52 ...
<b>F03</b>	Visual acceptance and report handover with acceptance		0/21, 3/52 ...
<b>F04</b>	Temperature-rise test, without acceptance		0/21, 3/53 ...
<b>F05</b>	Temperature-rise test, with acceptance		0/21, 3/53 ...
<b>F28</b>	Noise measurement during idling, no noise analysis, no acceptance		0/21, 3/53 ...
<b>F29</b>	Noise measurement during idling, no noise analysis, with acceptance		0/21, 3/53 ...
<b>F34</b>	Recording of current and torque curves with torque metering shaft during starting, without acceptance		0/21, 3/53 ...
<b>F35</b>	Recording of current and torque curves with torque metering shaft during starting, with acceptance		0/21, 3/53 ...
<b>F52</b>	Measurement of the locked-rotor torque and locked-rotor current, without acceptance		0/21, 3/53 ...
<b>F53</b>	Measurement of the locked-rotor torque and locked-rotor current, with acceptance		0/21, 3/53 ...
<b>F62</b>	Noise analysis, without acceptance		0/21, 3/53 ...
<b>F63</b>	Noise analysis, with acceptance		0/21, 3/53 ...
<b>F82</b>	Type test with heat run for horizontal motors, without acceptance		0/21, 3/53 ...
<b>F83</b>	Type test with heat run for horizontal motors, with acceptance		Marine version – Acceptance/certification
<b>F83</b>	Type test with heat run for horizontal motors, with acceptance	Packaging, safety notes, documentation and test certificates	0/21, 3/53 ...
<b>F92</b>	Type test with heat run for vertical motors, without acceptance		0/21, 3/53 ...
<b>F93</b>	Type test with heat run for vertical motors, with acceptance	Marine version – Acceptance/certification	10/23 ...
<b>F93</b>	Type test with heat run for vertical motors, with acceptance	Packaging, safety notes, documentation and test certificates	0/21, 3/53 ...
<b>G17</b>	Mounting of separately driven fan	Modular technology – Basic versions	0/76
<b>G26</b>	Mounting of brake		0/77 ...
<b>G50</b>	Measuring nipple for SPM shock pulse measurement for bearing inspection	Bearings and lubrication	0/58
<b>G55</b>	ECOFAST motor plug Han-Drive 10e for 230 VΔ/400 VY	Motor connection and connection box	0/51
<b>G56</b>	ECOFAST motor plug EMC Han-Drive 10e for 230 VΔ/400 VY		0/51
<b>H15</b>	Prepared for mounting MMI	Special technology	0/15, 0/85
<b>H17</b>	Fan cover for textile industry	Heating and ventilation	0/37
<b>H47</b>	Mounting of brake NFA (Stomag)	Special technology	0/85
<b>H57</b>	Mounting of 1XP8 001-1 (HTL) rotary pulse encoder	Modular technology – Basic versions	0/75
<b>H58</b>	Mounting of 1XP8 001-2 (TTL) rotary pulse encoder		0/75
<b>H61</b>	Mounting of separately driven fan and 1XP8 001-1 rotary pulse encoder	Modular technology – Combinations of basic versions	0/84
<b>H62</b>	Mounting of brake and 1XP8 001-1 rotary pulse encoder		0/84
<b>H63</b>	Mounting of brake and separately driven fan		0/84
<b>H64</b>	Mounting of brake, separately driven fan and 1XP8 001-1 rotary pulse encoder		0/84

**Overview of order codes  
1LA, 1LG, 1LL, 1LP, 1MA, 1MJ, 1PP, 1PQ**

Order codes	Special versions	Category	For further information, see Page
<b>H70</b>	Mounting of LL 861 900 220 rotary pulse encoder	Special technology	0/85
<b>H72</b>	Mounting of HOG 9 D 1024 I rotary pulse encoder		0/86
<b>H73</b>	Mounting of HOG 10 D 1024 I rotary pulse encoder		0/87
<b>H78</b>	Prepared for mounting LL 861 900 220		0/85
<b>H79</b>	Prepared for mounting HOG 9 D 1024 I		0/86
<b>H80</b>	Prepared for mounting HOG 10 D 1024 I		0/87
<b>H86</b>	Mounting of explosion-proof rotary pulse encoder for use in Zones 2, 21, 22		4/5, 4/6
<b>H87</b>	Mounting of explosion-proof rotary pulse encoder for use on Ex d/de motors in Zone 1	4/5, 4/6	
<b>H97</b>	Mounting of separately driven fan and 1XP8 001-2 rotary pulse encoder	Modular technology – Combinations of basic versions	0/84
<b>H98</b>	Mounting of brake and 1XP8 001-2 rotary pulse encoder		0/84
<b>H99</b>	Mounting of brake, separately driven fan and 1XP8 001-2 rotary pulse encoder		0/84
<b>J15</b>	Mounting of explosion-proof rotary pulse encoder HOG 10 DN 1024 I, connection box protection against moisture	Special technology	0/87
<b>J16</b>	Mounting of explosion-proof rotary pulse encoder HOG 10 DN 1024 I, connection box protection against dust		0/88
<b>K02</b>	Vibration quantity level B	Balance and vibration quantity	0/56
<b>K04</b>	Concentricity of shaft extension, coaxiality and linear movement in accordance with DIN 42955 Tolerance R for flange-mounting motors	Shaft and rotor	0/57
<b>K06</b>	Two-part plate on connection box	Motor connection and connection box	0/39
<b>K09</b>	Connection box on RHS		0/38
<b>K10</b>	Connection box on LHS		0/38
<b>K11</b>	Connection box on top, feet screwed on		0/38
<b>K15</b>	Connection box in cast-iron version		0/38, 0/47 ...
<b>K16</b>	Second standard shaft extension	Shaft and rotor	0/56
<b>K17</b>	Drive-end seal for flange-mounting motors with oil resistance to 0.1 bar	Mechanical design and degrees of protection	0/54
<b>K20</b>	Bearing design for increased cantilever forces	Bearings and lubrication	0/58, 0/62 ...
<b>K23</b>	Unpainted (only cast-iron parts primed)	Colors and paint finish	0/17
<b>K24</b>	Unpainted, only primed		0/17
<b>K26</b>	Special finish in RAL 7030 stone gray		0/18
<b>K30</b>	VIK design (comprises Zone 2 for mains-fed operation, without Ex nA II marking on rating plate)	Design for Zones 1, 2, 21 and 22 according to ATEX	4/83
<b>K31</b>	Second rating plate, loose	Rating plate and extra rating plates	0/30
<b>K32</b>	With two additional eyebolts for IM V1/IM V3	Mechanical design and degrees of protection	0/54
<b>K34</b>	Cast-iron fan cover	Heating and ventilation	0/37
<b>K35</b>	Metal external fan		0/37
<b>K36</b>	Special bearing for DE and NDE, bearing size 63	Bearings and lubrication	0/58, 0/63 ...
<b>K37</b>	Low-noise version for 2-pole motors with clockwise direction of rotation	Mechanical design and degrees of protection	0/55
<b>K38</b>	Low-noise version for 2-pole motors with counter-clockwise direction of rotation		0/55
<b>K40</b>	Regreasing device	Bearings and lubrication	0/58
<b>K42</b>	Shaft extension with standard dimensions, without featherkey way	Shaft and rotor	0/57
<b>K45</b>	Anti-condensation heaters for 230 V	Heating and ventilation	0/36
<b>K46</b>	Anti-condensation heaters for 115 V		0/36
<b>K50</b>	IP65 degree of protection	Mechanical design and degrees of protection	0/54
<b>K52</b>	IP56 degree of protection (non-heavy-sea)		0/54
<b>K53</b>	Explosion-proof connection box, Ex d IIC type of protection	Motor connection and connection box	0/38, 0/47 ...
<b>K54</b>	One cable gland, metal		0/39
<b>K55</b>	Cable gland, maximum configuration		0/39
<b>K57</b>	Cable gland DIN 89280, maximum configuration		0/39
<b>K82</b>	Manual brake release with lever	Modular technology - Additional versions	0/83
<b>K83</b>	Rotation of the connection box through 90°, entry from DE	Motor connection and connection box	0/39
<b>K84</b>	Rotation of the connection box through 90°, entry from NDE		0/39
<b>K85</b>	Rotation of connection box through 180°		0/39
<b>K94</b>	Located bearing DE	Bearings and lubrication	0/58
<b>L00</b>	Next larger connection box	Motor connection and connection box	0/38
<b>L01</b>	Undrilled entry plate		0/40
<b>L03</b>	Vibration-proof version	Mechanical design and degrees of protection	0/55
<b>L04</b>	Located bearing NDE	Bearings and lubrication	0/58
<b>L12</b>	Condensation drainage holes	Mechanical design and degrees of protection	0/54
<b>L13</b>	External earthing	Motor connection and connection box	0/38
<b>L27</b>	Insulated bearing cartridge	Bearings and lubrication	0/58
<b>L36</b>	Sheet metal fan cover	Heating and ventilation	0/37
<b>L39</b>	Concentricity of shaft extension in accordance with DIN 42955 Tolerance R	Shaft and rotor	0/57

# IEC Squirrel-Cage Motors

## Appendix

### Overview of order codes 1LA, 1LG, 1LL, 1LP, 1MA, 1MJ, 1PP, 1PQ

Order codes	Special versions	Category	For further information, see Page
<b>L44</b>	3 cables protruding, 0.5 m long	Motor connection and connection box	0/40
<b>L45</b>	3 cables protruding, 1.5 m long		0/40
<b>L47</b>	6 cables protruding, 0.5 m long		0/40
<b>L48</b>	6 cables protruding, 1.5 m long		0/40
<b>L49</b>	6 cables protruding, 3 m long		0/40
<b>L51</b>	Protruding cable ends – right side		0/40
<b>L52</b>	Protruding cable ends – left side		0/40
<b>L68</b>	Full key balancing	Balance and vibration quantity	0/56
<b>L97</b>	Auxiliary connection box 1XB3 020	Motor connection and connection box	0/50
<b>L99</b>	Wire-lattice pallet	Packaging, safety notes, documentation and test certificates	0/20
<b>M14</b>	Anti-condensation heater, Ex. 115 V	Heating and ventilation	0/36
<b>M15</b>	Anti-condensation heater, Ex. 230 V		0/36
<b>M27</b>	Non-rusting screws (externally)	Mechanical design and degrees of protection	0/55
<b>M32</b>	Connected in star for dispatch	Packaging, safety notes, documentation and test certificates	0/20
<b>M33</b>	Connected in delta for dispatch		0/20
<b>M34</b>	Design for Zone 21, as well as Zone 22 for conducting dust (IP65) for mains-fed operation	Design for Zones 1, 2, 21 and 22 according to ATEX	4/4, 4/81
<b>M35</b>	Design for Zone 22 for non-conducting dust (IP55) for mains-fed operation		4/4, 4/81
<b>M37</b>	Balancing without key	Balance and vibration quantity	0/56
<b>M38</b>	Design for Zone 21, as well as Zone 22 for conducting dust (IP65) for converter-fed operation, derating	Design for Zones 1, 2, 21 and 22 according to ATEX	4/4, 4/83
<b>M39</b>	Design for Zone 22 for non-conducting dust (IP55) for converter-fed operation, derating		4/4, 4/83
<b>M44</b>	Earth brushes for converter-fed operation	Mechanical design and degrees of protection	0/55
<b>M46</b>	Stud terminal for cable connection, accessories pack (3 items)	Motor connection and connection box	0/49
<b>M47</b>	Saddle terminal for connection without cable lug, accessories pack		0/49
<b>M50</b>	Auxiliary connection box 1XB9 016		0/50
<b>M58</b>	Next larger connection box 1XB1 621		0/38
<b>M64</b>	Connection box on NDE		0/38
<b>M65</b>	Standard shaft made of non-rusting steel	Shaft and rotor	0/57
<b>M68</b>	Mechanical protection for encoder	Mechanical design and degrees of protection	0/55
<b>M69</b>	Terminal strip for main and auxiliary terminals	Motor connection and connection box	0/49
<b>M72</b>	Design for Zone 2 for mains-fed operation Ex nA II T3 to IEC/EN 60079-15	Design for Zones 1, 2, 21 and 22 according to ATEX	4/4, 4/81
<b>M73</b>	Design for Zone 2 for converter-fed operation, derating Ex nA II T3 to IEC/EN 60079-15		4/4, 4/83
<b>M74</b>	Design for Zones 2 and 22, for non-conducting dust (IP55), for mains-fed operation		4/81
<b>M75</b>	Design for Zones 2 and 22, for non-conducting dust (IP55), for converter-fed operation, derating		4/83
<b>M76</b>	Design for Zones 1 and 21, as well as for Zone 22 for conducting dust (IP65), for mains-fed operation		4/81
<b>M77</b>	Design for Zones 1 and 21, as well as for Zone 22 for conducting dust (IP65), for converter-fed operation, derating		4/82
<b>M88</b>	Auxiliary connection box 1XB9 014 (aluminum)	Motor connection and connection box	0/50
<b>M91</b>	Offshore special finish	Colors and paint finish	0/17
<b>M94</b>	Sea air resistant special finish		0/17
<b>M95</b>	Mounting of explosion-proof separately driven fan Ex nA for use in Zone 2	Special technology	4/5, 4/8
<b>M96</b>	Mounting of explosion-proof separately driven fan II 2D for use in Zone 21		4/5, 4/8
<b>M97</b>	Mounting of explosion-proof separately driven fan II 3D for use in Zone 22		4/5, 4/8
<b>M98</b>	Mounting of explosion-proof separately driven fan Ex de for use in Zone 1		4/5, 4/8
<b>Y50</b>	Temperature class 155 (F), used acc. to 130 (B), with increased coolant temperature and/or site altitude	Windings and insulation	0/33
<b>Y51</b>	Special finish in special RAL colors	Colors and paint finish	0/17, 0/19
<b>Y52</b>	Temperature class 155 (F), used acc. to 155 (F), other requirements	Windings and insulation	0/33
<b>Y53</b>	Standard finish in other standard RAL colors	Colors and paint finish	0/17, 0/18
<b>Y54</b>	Special finish in other standard RAL colors		0/17, 0/18



Order codes	Special versions	Category	For further information, see Page
<b>Y55</b>	Non-standard cylindrical shaft extension	Shaft and rotor	0/57
<b>Y68</b>	Alternative converter (SIMOVERT MASTERDRIVES, SINAMICS G110, SINAMICS S120 or ET 200 S FC)	Design for Zones 1, 2, 21 and 22 according to ATEX	4/82
<b>Y70</b>	Mounting a special type of rotary pulse encoder	Special technology	0/85
<b>Y74</b>	Mounting of rotary pulse encoder HOG 10 DN 1024 I + FSL, (speed .... rpm), connection box protection against moisture		0/88
<b>Y76</b>	Mounting of rotary pulse encoder HOG 10 DN 1024 I + FSL, (speed .... rpm), connection box protection against dust		0/89
<b>Y79</b>	Mounting of rotary pulse encoder HOG 10 DN 1024 I + E SL 93, (speed .... rpm), connection box protection against moisture		0/89
<b>Y80</b>	Extra rating plate or rating plate with deviating rating plate data	Rating plate and extra rating plates	0/30
<b>Y81</b>	Separately driven fan with non-standard voltage and/or frequency	Heating and ventilation	0/37
<b>Y82</b>	Extra rating plate with identification code	Rating plate and extra rating plates	0/30
<b>Y84</b>	Additional information on rating plate and on package label (maximum of 20 characters)		0/30

# IEC Squirrel-Cage Motors

## Appendix

### Overview of order codes 1LE1, 1PC1

#### Order codes for 1LE1 and 1PC1 motors

All options are alphanumerically listed according to order codes in the following table.

A list of all available options according to categories can be found in catalog part 0 under "Introduction motors 1LE1, 1PC1", "Special versions".

Order codes	Special versions	Category	For further information, see Page	
<b>B00</b>	Without safety and commissioning note. Customer's declaration of renouncement required.	Packaging, safety notes, documentation and test certificates	0/102	
<b>B01</b>	Complete with one set of safety and commissioning notes per wire-lattice pallet		0/102	
<b>B02</b>	Acceptance test certificate 3.1 according to EN 10204		0/102	
<b>B04</b>	Printed operating instructions English/German enclosed		0/102	
<b>B83</b>	Type test with heat run for horizontal motors, with acceptance		0/102	
<b>B99</b>	Wire-lattice pallet		0/102	
<b>D03</b>	Coolant temperature -40 to +40 °C	Coolant temperature and site altitude	0/107	
<b>D04</b>	Coolant temperature -30 to +40 °C		0/107	
<b>D30</b>	Electrical according to NEMA MG1-12	Designs in accordance with standards and specifications	0/99	
<b>D31</b>	Design according to UL with "Recognition Mark"		0/99	
<b>D40</b>	Canadian regulations (CSA)		0/98, 0/99	
<b>D46</b>	PSE Mark Japan		0/99	
<b>F01</b>	Mounting of brake	Modular technology - Basic versions	0/130 ...	
<b>F10</b>	Brake supply voltage 24 V DC		0/133	
<b>F11</b>	Brake supply voltage 230 V AC, 50/60 Hz		0/133	
<b>F12</b>	Brake supply voltage 400 V AC		0/133	
<b>F50</b>	Mechanical manual brake release with lever		0/133	
<b>F70</b>	Mounting of separately driven fan		0/129	
<b>F74</b>	Sheet metal fan cover		Heating and ventilation	0/111
<b>F75</b>	Fan cover for textile industry	0/111		
<b>F76</b>	Metal external fan	0/111		
<b>F77</b>	Low-noise version for 2-pole motors with clockwise direction of rotation	Mechanical design and degrees of protection	0/119	
<b>F78</b>	Low-noise version for 2-pole motors with counter-clockwise direction of rotation		0/119	
<b>G01</b>	Mounting of 1XP8012-10 (HTL) rotary pulse encoder	Modular technology - Basic versions	0/128	
<b>G02</b>	Mounting of 1XP8012-20 (TTL) rotary pulse encoder		0/128	
<b>G04</b>	Anbau des Drehimpulsgebers LL 861 900 220		Special technology	0/134
<b>G05</b>	Mounting of LL 861 900 220 rotary pulse encoder			0/135
<b>G06</b>	Mounting of HOG 10 D 1024 I rotary pulse encoder			0/136
<b>G40</b>	Prepared for mountings, only center hole		Mechanical design and degrees of protection	0/118
<b>G41</b>	Prepared for mountings with D12 shaft	0/118		
<b>G42</b>	Prepared for mountings with D16 shaft	0/118		
<b>G43</b>	Protective cover for encoder (loosely enclosed – only for mountings acc. to order codes G40, G41 and G42)	0/118		
<b>H00</b>	Protective cover for types of construction		0/119	
<b>H01</b>	Screwed-on feet (instead of cast)		0/113	
<b>H02</b>	Vibration-proof version		0/119	
<b>H03</b>	Condensation drainage holes		0/119	
<b>H04</b>	External earthing	Motor connection and connection box	0/113	
<b>H07</b>	Non-rusting screws (externally)	Mechanical design and degrees of protection	0/119	
<b>H08</b>	Connection box on NDE	Motor connection and connection box	0/113	
<b>H20</b>	IP65 degree of protection	Mechanical design and degrees of protection	0/119	
<b>H22</b>	IP56 degree of protection (non-heavy-sea)		0/119	
<b>H23</b>	Radial seal on DE for flange-mounting motors with oil resistance to 0.1 bar		0/118	
<b>L00</b>	Vibration quantity level B	Balance and vibration quantity	0/120	
<b>L01</b>	Balancing without fitted key		0/120	
<b>L02</b>	Full-key balancing		0/120	
<b>L04</b>	Shaft extension with standard dimensions, without featherkey way	Shaft and rotor	0/121	
<b>L05</b>	Second standard shaft extension		0/121	
<b>L06</b>	Standard shaft made of non-rusting steel		0/121	
<b>L07</b>	Concentricity of shaft extension in accordance with DIN 42955 Tolerance R		0/121	
<b>L08</b>	Concentricity of shaft extension, coaxiality and linear movement in accordance with DIN 42955 Tolerance R for flange-mounting motors		0/121	
<b>L20</b>	Located bearing at DE	Bearings and lubrication	0/122	
<b>L21</b>	Located bearing at NDE		0/122	
<b>L22</b>	Bearing design for increased cantilever forces		0/122, 0/124 ...	
<b>L23</b>	Regreasing device		0/122	
<b>L25</b>	Special bearing for DE and NDE, bearing size 63		0/122, 0/124 ...	
<b>M01</b>	Connected in star for dispatch		Packaging, safety notes, documentation and test certificates	0/102
<b>M02</b>	Connected in delta for dispatch	0/102		

Order codes	Special versions	Category	For further information, see Page
<b>M10</b>	Second rating plate, loose	Rating plate and extra rating plates	0/106
<b>M11</b>	Nirosta rating plate		0/106
<b>N01</b>	Temperature class 155 (F), used acc. to 155 (F), with service factor (SF)	Windings and insulation	0/108
<b>N02</b>	Temperature class 155 (F), used acc. to 155 (F), with increased output		0/108
<b>N03</b>	Temperature class 155 (F), used acc. to 155 (F), with increased coolant temperature		0/108
<b>N05</b>	Temperature class 155 (F), used acc. to 130 (B), coolant temperature 45 °C, derating approx. 4 %		0/108
<b>N06</b>	Temperature class 155 (F), used acc. to 130 (B), coolant temperature 50 °C, derating approx. 8 %		0/108
<b>N07</b>	Temperature class 155 (F), used acc. to 130 (B), coolant temperature 55 °C, derating approx. 13 %		0/108
<b>N08</b>	Temperature class 155 (F), used acc. to 130 (B), coolant temperature 60 °C, derating approx. 18 %		0/108
<b>N11</b>	Temperature class 180 (H) at rated power and max. CT 60 °C		0/108
<b>N20</b>	Increased air humidity/temperature with 30 to 60 g water per m <sup>3</sup> of air		0/108
<b>N21</b>	Increased air humidity/temperature with 60 to 100 g water per m <sup>3</sup> of air		0/108
<b>Q01</b>	Measuring nipple for SPM shock pulse measurement for bearing inspection	Bearings and lubrication	0/122
<b>Q02</b>	Anti-condensation heaters for 230 V	Heating and ventilation	0/111
<b>Q03</b>	Anti-condensation heaters for 115 V		0/111
<b>R10</b>	Rotation of the connection box through 90°, entry from DE	Motor connection and connection box	0/114
<b>R11</b>	Rotation of the connection box through 90°, entry from NDE		0/114
<b>R12</b>	Rotation of the connection box through 180°		0/114
<b>R15</b>	One cable gland, metal		0/114
<b>R20</b>	3 cables protruding, 0.5 m long		0/114
<b>R21</b>	3 cables protruding, 1.5 m long		0/114
<b>R22</b>	6 cables protruding, 0.5 m long		0/114
<b>R23</b>	6 cables protruding, 1.5 m long		0/114
<b>R24</b>	6 cables protruding, 3 m long		0/114
<b>R30</b>	Reduction piece for M cable gland in accordance with British standard, both cable entries mounted		0/114
<b>R50</b>	Larger connection box		0/113
<b>S00</b>	Unpainted (only cast iron parts primed)	Colors and paint finish	0/100
<b>S01</b>	Unpainted, only primed		0/100
<b>S03</b>	Special finish sea air resistant		0/100
<b>Y51</b>	Special finish in special RAL colors		0/101
<b>Y52</b>	Temperature class 155 (F), used acc. to 155 (F), other requirements	Windings and insulation	0/108
<b>Y54</b>	Special finish in other standard RAL colors	Colors and paint finish	0/101
<b>Y55</b>	Non-standard cylindrical shaft extension	Shaft and rotor	0/121
<b>Y80</b>	Extra rating plate or rating plate with deviating rating plate data	Rating plate and extra rating plates	0/106
<b>Y82</b>	Extra rating plate with identification codes		0/106
<b>Y84</b>	Additional information on rating plate and on package label (max. of 20 characters)		0/106

# IEC Squirrel-Cage Motors

## Appendix

Notes



# IEC Squirrel-Cage Motors

## Appendix

Notes



# IEC Squirrel-Cage Motors

## Appendix

### Metal surcharges

#### Explanation of the metal factor

Surcharges will be added to the prices of products that contain silver, copper, aluminum, lead and/or gold if the respective basic official prices for these metals are exceeded.

The surcharges will be determined based on the following criteria:

- Official price of the metal  
Official price on the day prior to receipt of the order or prior to the release order (=daily price) for
  - silver (sale price of the processed material),
  - gold (sale price of the processed material)
 Source: Umicore, Hanau  
(<http://www.metalsmanagement.umicore.com>)  
and for
  - copper (low DEL notation + 1 %),
  - aluminum (aluminum in cables) and
  - lead (lead in cables)
 Source: German Trade Association for Cables and Conductors  
(<http://www.kabelverband.de>)
- Metal factor of the products  
Certain products are assigned a metal factor. The metal factor determines the official price as of which the metal surcharges are charged and the calculation method used (weight or percentage method). An exact explanation is given below.

#### Structure of the metal factor

The metal factor consists of several digits; the first digit indicates whether the method of calculation refers to the list price or a discounted price (customer net price) (L = list price / N = customer net price).

The remaining digits indicate the method of calculation used for the respective metal. If no surcharge is added, a "-" is used.

1st digit	List or customer net price using the percentage method
2nd digit	for silver (AG)
3rd digit	for copper (CU)
4th digit	for aluminum (AL)
5th digit	for lead (PB)
6th digit	for gold (AU)

#### Weight method

The weight method uses the basic official price, the daily price and the raw material weight. In order to calculate the surcharge, the basic official price must be subtracted from the daily price. The result is then multiplied by the raw material weight.

The basic official price can be found in the table below using the number (2 to 9) of the respective digit of the metal factor. The raw material weight can be found in the respective product descriptions.

#### Percentage method

Use of the percentage method is indicated by the letters A-Z at the respective digit of the metal factor.

The surcharge is increased – dependent on the deviation of the daily price compared with the basic official price – using the percentage method in "steps" and consequently offers surcharges that remain constant within the framework of this "step range". A higher percentage rate is charged for each new step. The respective percentage level can be found in the table below.

#### Metal factor examples

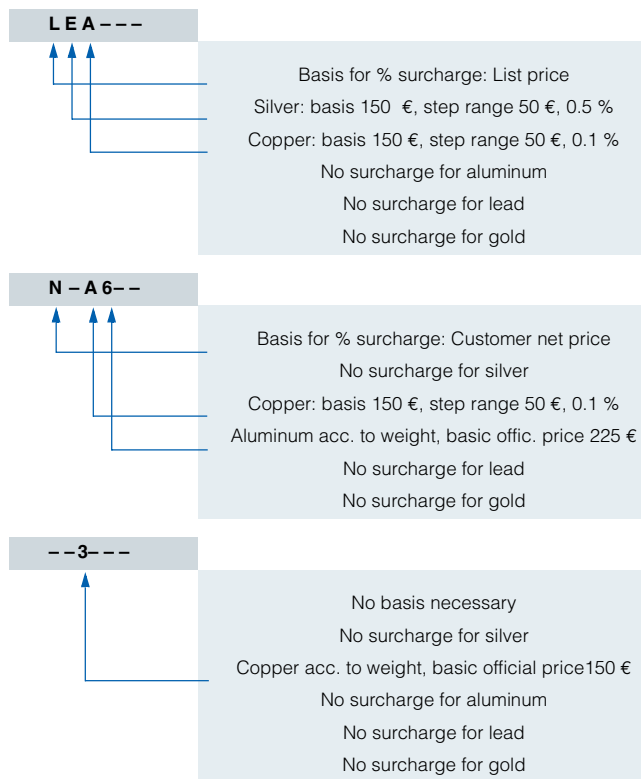

A&amp;D/MZ\_1/En 05.09.06



## Values of the metal factor

Percentage method	Basic official price	Step range	% surcharge	% surcharge	% surcharge	% surcharge	% surcharge per
			1st step	2nd step	3rd step	4th step	additional step
			Official price	Official price	Official price	Official price	
			151 € – 200 €	201 € – 250 €	251 € – 300 €	301 € – 350 €	
A	150	50	0.1	0.2	0.3	0.4	0.1
B	150	50	0.2	0.4	0.6	0.8	0.2
C	150	50	0.3	0.6	0.9	1.2	0.3
D	150	50	0.4	0.8	1.2	1.6	0.4
E	150	50	0.5	1.0	1.5	2.0	0.5
F	150	50	0.6	1.2	1.8	2.4	0.6
G	150	50	0.7	1.4	2.1	2.8	0.7
H	150	50	1.2	2.4	3.6	4.8	1.2
I	150	50	1.6	3.2	4.8	6.4	1.6
J	150	50	1.8	3.6	5.4	7.2	1.8
K	150	50	2.0	3.5	5.0	6.5	1.5
L	150	50	2.2	4.4	6.6	8.8	2.2
M	150	50	2.5	5.0	7.5	10.0	2.5
			176 € – 225 €	226 € – 275 €	276 € – 325 €	326 € – 375 €	
O	175	50	0.1	0.2	0.3	0.4	0.1
P	175	50	0.2	0.4	0.6	0.8	0.2
Q	175	50	0.3	0.6	0.9	1.2	0.3
R	175	50	0.5	1.0	1.5	2.0	0.5
			226 € – 275 €	276 € – 325 €	326 € – 375 €	376 € – 425 €	
S	225	50	0.2	0.4	0.6	0.8	0.2
T	225	50	0.5	1.0	1.5	2.0	0.5
U	225	50	1.0	2.0	3.0	4.0	1.0
V	225	50	1.0	1.5	2.0	3.0	1.0
W	225	50	1.2	2.5	3.5	4.5	1.0
			126 € – 150 €	151 € – 175 €	176 € – 200 €	201 € – 225 €	
X	125	25	1.9	3.8	5.7	7.6	1.9
			151 € – 175 €	176 € – 200 €	201 € – 225 €	226 € – 250 €	
Y	150	25	0.3	0.6	0.9	1.2	0.3
			401 € – 425 €	426 € – 450 €	451 € – 475 €	476 € – 500 €	
Z	400	25	0.1	0.2	0.3	0.4	0.1
<b>Price basis (1st digit)</b>							
L	Charged on the list price						
N	Charged on the customer net price or discounted list price						
<b>Weight method</b>	<b>Basic official price</b>						
2	100						
3	150						
4	175						
5	200						
6	225						
7	300						
8	400						
9	555						
<b>Misc.</b>							
-	No metal surcharge						

Calculation based on raw material weight

# IEC Squirrel-Cage Motors

## Appendix

### Conditions of sale and delivery

#### Terms and Conditions of Sale and Delivery

By using this catalog you can acquire hardware and software products described therein from Siemens AG subject to the following terms. Please note! The scope, the quality and the conditions for supplies and services, including software products, by any Siemens entity having a registered office outside of Germany, shall be subject exclusively to the General Terms and Conditions of the respective Siemens entity. The following terms apply exclusively for orders placed with Siemens AG.

##### *For customers with a seat or registered office in Germany*

The "General Terms of Payment" as well as the "General Conditions for the Supply of Products and Services of the Electrical and Electronics Industry" shall apply.

For software products, the "General License Conditions for Software Products for Automation and Drives for Customers with a Seat or registered Office in Germany" shall apply.

##### *For customers with a seat or registered office outside of Germany*

The "General Terms of Payment" as well as the "General Conditions for Supplies of Siemens Automation and Drives for Customers with a Seat or registered Office outside of Germany" shall apply.

For software products, the "General License Conditions for Software Products for Automation and Drives for Customers with a Seat or registered Office outside of Germany" shall apply.

##### *General*

The dimensions are in mm. In Germany, according to the German law on units in measuring technology, data in inches only apply to devices for export.

Illustrations are not binding.

Insofar as there are no remarks on the corresponding pages, – especially with regard to data, dimensions and weights given – these are subject to change without prior notice.

The prices are in € (Euro) ex works, exclusive packaging.

The sales tax (value added tax) is not included in the prices. It shall be debited separately at the respective rate according to the applicable legal regulations.

Prices are subject to change without prior notice. We will debit the prices valid at the time of delivery.

Surcharges will be added to the prices of products that contain silver, copper, aluminum, lead and/or gold, if the respective basic official prices for these metals are exceeded. These surcharges will be determined based on the official price and the metal factor of the respective product.

The surcharge will be calculated on the basis of the official price on the day prior to receipt of the order or prior to the release order.

The metal factor determines the official price as of which the metal surcharges are charged and the calculation method used. The metal factor, provided it is relevant, is included with the price information of the respective products. An exact explanation of the metal factor can be found on the page entitled "Metal surcharges".

The texts of the Comprehensive Terms and Conditions of Sale and Delivery are available free of charge from your local Siemens business office under the following Order Nos.:

- 6ZB5310-0KR30-0BA1  
(for customers based in Germany)
- 6ZB5310-0KS53-0BA1  
(for customers based outside of Germany)

or download them from the Internet  
<http://www.siemens.com/automation/mall>  
(Germany: A&D Mall Online-Help System)

#### Export regulations

The products listed in this catalog / price list may be subject to European / German and/or US export regulations.

Therefore, any export requiring a license is subject to approval by the competent authorities.

According to current provisions, the following export regulations must be observed with respect to the products featured in this catalog / price list:

AL	<p>Number of the <u>German Export List</u></p> <p>Products marked other than "N" require an export license.</p> <p>In the case of software products, the export designations of the relevant data medium must also be generally adhered to.</p> <p>Goods labeled with an "<u>AL" not equal to "N"</u> are subject to a European or German export authorization when being exported out of the EU.</p>
ECCN	<p><u>Export Control Classification Number</u>.</p> <p>Products marked other than "N" are subject to a reexport license to specific countries.</p> <p>In the case of software products, the export designations of the relevant data medium must also be generally adhered to.</p> <p>Goods labeled with an "<u>ECCN" not equal to "N"</u> are subject to a US re-export authorization.</p>

Even without a label or with an "AL: N" or "ECCN: N", authorization may be required due to the final destination and purpose for which the goods are to be used.

The deciding factors are the AL or ECCN export authorization indicated on order confirmations, delivery notes and invoices.

Errors excepted and subject to change without prior notice.

A&D/VuL\_mit MZ/En 05.09.06

## Industry Automation, Drive Technologies and Electrical Installation Technology

Further information can be obtained from our branch offices listed in the appendix or at [www.siemens.com/automation/partner](http://www.siemens.com/automation/partner)

<b>Automation and Drives</b>	<i>Catalog</i>	<b>Low-Voltage</b>	<i>Catalog</i>
Interactive catalog on DVD	CA 01	Controls and Distribution – SIRIUS, SENTRON, SIVACON	LV 1
<b>Drive Systems</b>		Controls and Distribution – Technical Information SIRIUS, SENTRON, SIVACON	LV 1 T
<u>Variable-Speed Drives</u>		SIDAC Reactors and Filters	LV 60
SINAMICS G110/SINAMICS G120 Inverter Chassis Units	D 11.1	SIVENT Fans	LV 65
SINAMICS G120D		SIVACON 8PS Busbar Trunking Systems	LV 70
Distributed Frequency Inverters			
SINAMICS G130 Drive Converter Chassis Units, SINAMICS G150 Drive Converter Cabinet Units	D 11	<b>Motion Control</b>	
SINAMICS GM150/SINAMICS SM150 Medium-Voltage Converters	D 12	SINUMERIK & SIMODRIVE Automation Systems for Machine Tools	NC 60
SINAMICS S150 Drive Converter Cabinet Units	D 21.3	SINUMERIK & SINAMICS Automation Systems for Machine Tools	NC 61
Asynchronous Motors Standardline	D 86.1	SIMOTION, SINAMICS S120 and Motors for Production Machines	PM 21
Synchronous Motors with Permanent-Magnet Technology, HT-direct	D 86.2		
DC Motors	DA 12	<b>Process Instrumentation and Analytics</b>	
SIMOREG DC MASTER 6RA70 Digital Chassis Converters	DA 21.1	Field Instruments for Process Automation	FI 01
SIMOREG K 6RA22 Analog Chassis Converters	DA 21.2	Measuring Instruments for Pressure, Differential Pressure, Flow, Level and Temperature, Positioners and Liquid Meters	
<i>PDF: SIMOREG DC MASTER 6RM70 Digital Converter Cabinet Units</i>	<i>DA 22</i>	<i>PDF: Indicators for panel mounting</i>	<i>MP 12</i>
SIMOVERT PM Modular Converter Systems	DA 45	SIREC Recorders and Accessories	MP 20
SIEMOSYN Motors	DA 48	SIPART, Controllers and Software	MP 31
MICROMASTER 420/430/440 Inverters	DA 51.2	SIWAREX Weighing Systems	WT 01
MICROMASTER 411/COMBIMASTER 411	DA 51.3	Continuous Weighing and Process Protection	WT 02
SIMOVERT MASTERDRIVES Vector Control	DA 65.10	Process Analytical Instruments	PA 01
SIMOVERT MASTERDRIVES Motion Control	DA 65.11	<i>PDF: Process Analytics, Components for the System Integration</i>	<i>PA 11</i>
Synchronous and asynchronous servomotors for SIMOVERT MASTERDRIVES	DA 65.3		
SIMODRIVE 611 universal and POSMO	DA 65.4	<b>SIMATIC Industrial Automation Systems</b>	
<u>Low-Voltage Three-Phase-Motors</u>		Products for Totally Integrated Automation and Micro Automation	ST 70
IEC Squirrel-Cage Motors	D 81.1	SIMATIC PCS 7 Process Control System	ST PCS 7
MOTOX Geared Motors	D 87.1	Add-ons for the SIMATIC PCS 7 Process Control System	ST PCS 7.1
<u>Automation Systems for Machine Tools SIMODRIVE</u>	NC 60	Migration solutions with the SIMATIC PCS 7 Process Control System	ST PCS 7.2
• Motors		pc-based Automation	ST PC
• Converter Systems SIMODRIVE 611/POSMO		SIMATIC Control Systems	ST DA
<u>Automation Systems for Machine Tools SINAMICS</u>	NC 61		
• Motors		<b>SIMATIC NET</b>	
• Drive System SINAMICS S120		Industrial Communication	IK PI
SIMOTION, SINAMICS S120 and Motors for Production Machines	PM 21		
<u>Drive and Control Components for Hoisting Equipment</u>	HE 1	<b>SIMATIC Sensors</b>	
<u>Mechanical Driving Machines</u>		Sensors for Factory Automation	FS 10
Flender Standard Couplings	MD 10.1		
<b>Electrical Installation Technology</b>		<b>Systems Engineering</b>	
<i>PDF: ALPHA Small Distribution Boards and Distribution Boards, Terminal Blocks</i>	<i>ETA 1</i>	Power supplies SITOP power and LOGO! Power	KT 10.1
<i>PDF: ALPHA 8HP Molded-Plastic Distribution System</i>	<i>ETA 3</i>	System cabling SIMATIC TOP connect	KT 10.2
<i>PDF: BETA Low-Voltage Circuit Protection</i>	<i>ET B1</i>		
<i>PDF: DELTA Switches and Socket Outlets</i>	<i>ET D1</i>	<b>System Solutions</b>	
GAMMA Building Controls	ET G1	Applications and Products for Industry are part of the interactive catalog CA 01	
<b>Human Machine Interface Systems SIMATIC HMI</b>	ST 80	<b>TELEPERM M Process Control System</b>	
		<i>PDF: AS 488/TM automation systems</i>	<i>PLT 112</i>

*PDF: These catalogs are only available as pdf files.*

Siemens AG  
Industry Sector  
Drive Technologies  
Standard Drives  
Postfach 31 80  
91050 ERLANGEN  
GERMANY

[www.siemens.com/motors](http://www.siemens.com/motors)

Subject to change without prior notice  
Order No. E86060-K5581-A111-A3-7600  
Dispo 18404  
KG 1208 15. E 816 En / 3P.8122.67.02  
Printed in Germany  
© Siemens AG 2008

The information provided in this catalog contains descriptions or characteristics of performance which in case of actual use do not always apply as described or which may change as a result of further development of the products. An obligation to provide the respective characteristics shall only exist if expressly agreed in the terms of contract. Availability and technical specifications are subject to change without notice.

All product designations may be trademarks or product names of Siemens AG or supplier companies whose use by third parties for their own purposes could violate the rights of the owners.

# SIEMENS Catalog 81.1 • 2008 IEC Squirel-Cage Motors