

rotork®

Gears

DSIR Gearbox

Dual Speed Input Reducer

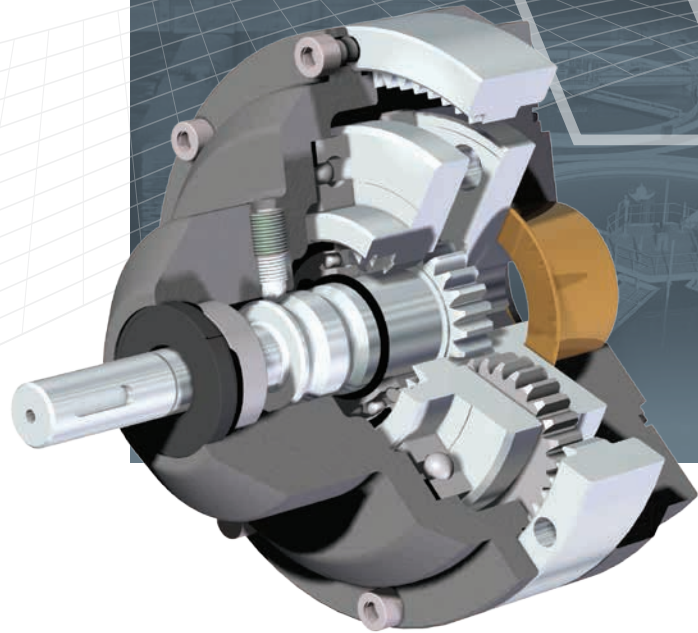

Manual Gearbox Applications - Dual Speed Input Reducer

Rotork Gears has developed a new Dual Speed Input Reducer for reducing the operating time on manual gearbox applications.

The DSIR can be used with any manual gearbox or valve with an input flange of F14 or FA14. It is used to reduce the number of input turns required and therefore the operating time for manually operated valves.

Application

The DSIR has two ratios: 1:1 and 4.25:1. Switching between the two ratios is done by simply pushing or pulling on the input shaft. The high 4.25:1 ratio gearing is used for the portion of the valve stroke where the torque requirement is high to initially open a valve or the last cycles to close it.

During travel the valve torque usually drops considerably and the lower 1:1 ratio can be employed to reduce the number of input turns required. Typically this can provide a 70% reduction in the number of turns required and the operating time.

Environmental Specification

- IP67 Enclosure
- Temperature -40 to 120 °C

Options

- IP68 Enclosure
- Padlocking device
- Flexible extensions
- Output machining to mount direct to valve

Redefining Flow Control

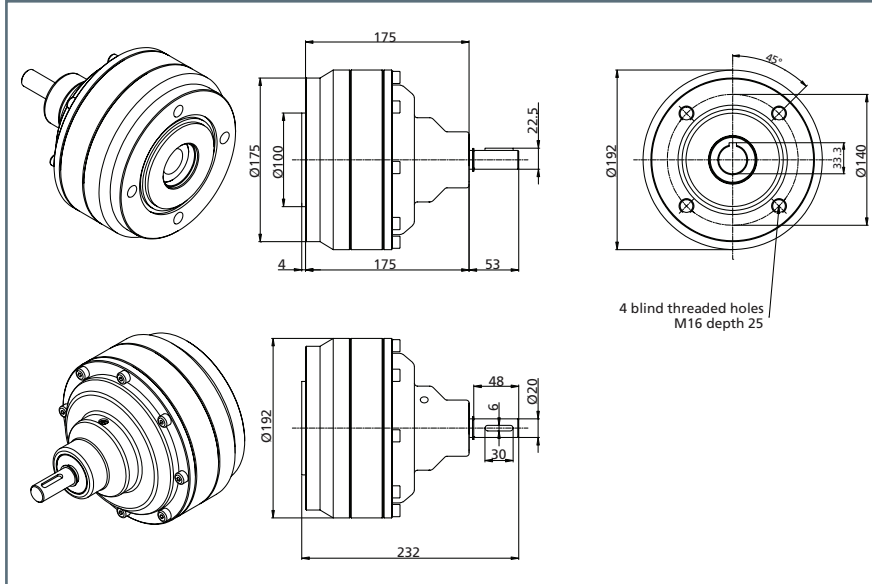

Product Data

Input Nm	180
Input lbf.in	1593
Ratio	1:1 & 4.25:1
MA for Higher ratio	4 ±4%
Output Nm	720
Output lbf.in	6373
Max bore mm	30
Max stem height mm	60
Weight kg	25

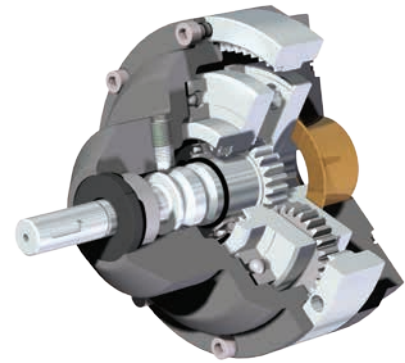

DSIR Manual Gearbox Material Specification

Components	Material	Notes
Body	Cast Iron	EN-GJL-250
Coverplate	Cast Iron	EN-GJL-250
Input Shaft	Alloy Steel	39NiCrMo3
Radial Ball Bearings	Carbon Steel	
O-ring Seal	NBR	
Planets	Alloy Steel	39NiCrMo3
Planetary External Gear Ring	Carbon Steel	ST52.0S
Planet Carrier	Ductile Iron	EN-GJS-700-2

Rotork Gears BV
Nijverheidstraat 25
7581 PV Losser
P.O. Box 98
7580 AB Losser
The Netherlands

tel +31 (0)53-5388677
fax +31 (0)53-5383939
email info@rotorkgears.nl

Rotork Gears UK
9 Brown Lane West
Holbeck
Leeds
West Yorkshire LS12 6BH
England

tel +44 (0)113 2567922
email sales@rotorkgears.com

Rotork Gears Americas
1811 Brittmoore
Houston
Texas 77043
USA

tel +1 713 983 7381
fax +1 713 856 8022
email gears@rotorkgears.com

Rotork Gears S.R.L.
via Olona, 65/67
20015 Parabiago (MI)
Italy

tel +39 0331 552128
fax +39 0331 553147
email info@rotorkgears.it

Rotork Gears Shanghai
No. 260 Lian Cao Road
Xin Mei Urban Industrial Park
Min Hang District
Shang Hai 201108
China

tel 0086-21-33236200
fax 0086-21-64348388
email info@rotorkgears.com.cn

A full listing of our worldwide sales and service network is available on our website at

www.rotork.com

Rotork Gears India
165/166, Bommasandra,
Jigani Link Road,
Kiadb Industrial Area,
Anekal Thaluk, Jigani Hobli,
Bangalore 562106

tel +91 80 3098 1600
fax +91 80 3098 1610
email sales@rotork.co.in

Rotork Valvekits
Brookside Way
Nunn Park
Huthwaite
Nottinghamshire NG17 2NL
England

tel +44 (0)1623 440211
fax +44 (0)1623 440214
email sales@rotorkvalvekits.com

Rotork Valvekits Americas
Renfro Associates Inc
501 South 12th Street
Broken Arrow, OK
74012
USA

tel +1 (918) 259-8100
fax +1 (918) 259-9167
email info@renfroassociates.com