

rotork®

Gears

IW Series AWWA

C504 and C5PV-3 Quarter-turn
Worm Gear Operator

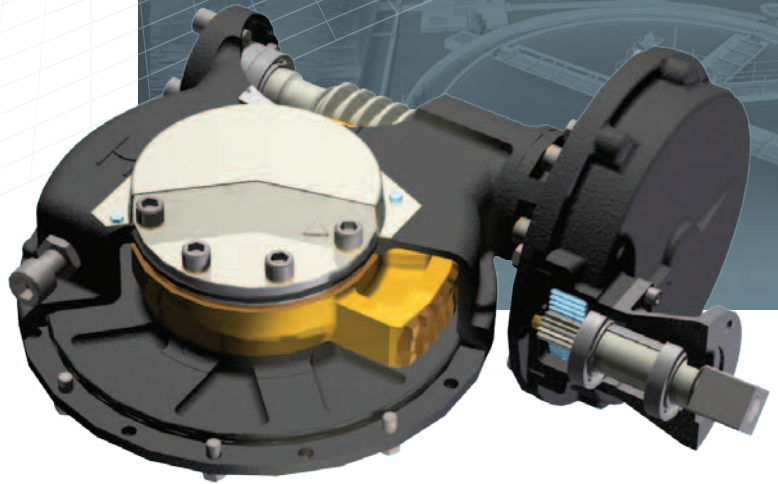

IW Quarter-turn Worm Gear Operator

The IW AWWA C504 & C5PV-3 worm gear operators are suitable for manual actuation of AWWA C504 butterfly valves and C5PV-3 plug valves. They are designed to meet or exceed all aspects of AWWA C504 & C5PV-3 specification and are manufactured from high quality and reliable materials. Overload and life tests reports are available upon request. All Rotork Gears actuators are made to ISO 9001 standards.

Features

- 100% grease filled for life and fully sealed
- Comprehensive gear ratios combined with a selection of input gear reducers
- Angular contact bearings supporting the worm shaft
- Removable and repositionable drive sleeve
- -40 to 250 °F standard temperature range
- Adjustable travel stops +/- 5 degrees
- Maximum rated output torque - 1.47 million in-lbs
- Maximum stem acceptance diameter - 12" bored with ANSI B17.1 square key
- Maximum base - FA40
- Above or Buried Service

Options

- Stem extensions
- Padlock kit
- NAMUR & Westlock Position indicator mounting kit
- High temperature: 0 to 300 °F
- Low temperature down to -60 °F
- Open Right Service
- 450 ft-lbs Service

Established Leaders in Actuation Technology

Material Specification

Component	Material	Specification / Notes
Gearcase	Ductile Iron	ASTM A536 65-45-12
Base plate	Cast Iron	ASTM A48 35B/40B
Worm Shaft	Steel	AISI 4340
Quadrant	Manganese Bronze	ASTM B584 C86300
Position Indicator	Steel	AISI 1023
Drive sleeve	Steel	AISI 1023 or 1040 or 1055
Bearings	Angular Contact	
O-Ring seals	Nitrile	
Fasteners	316 SS	
Grease	Renolit CL-X2	
Input Shaft	431 SS	

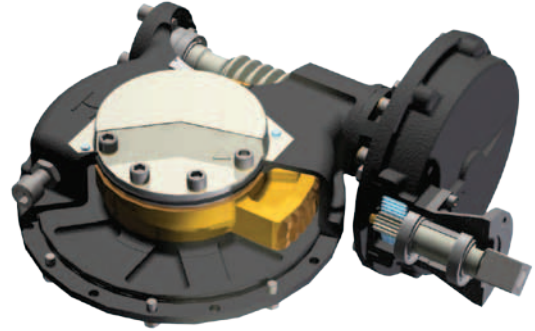

Handwheel Selection Chart

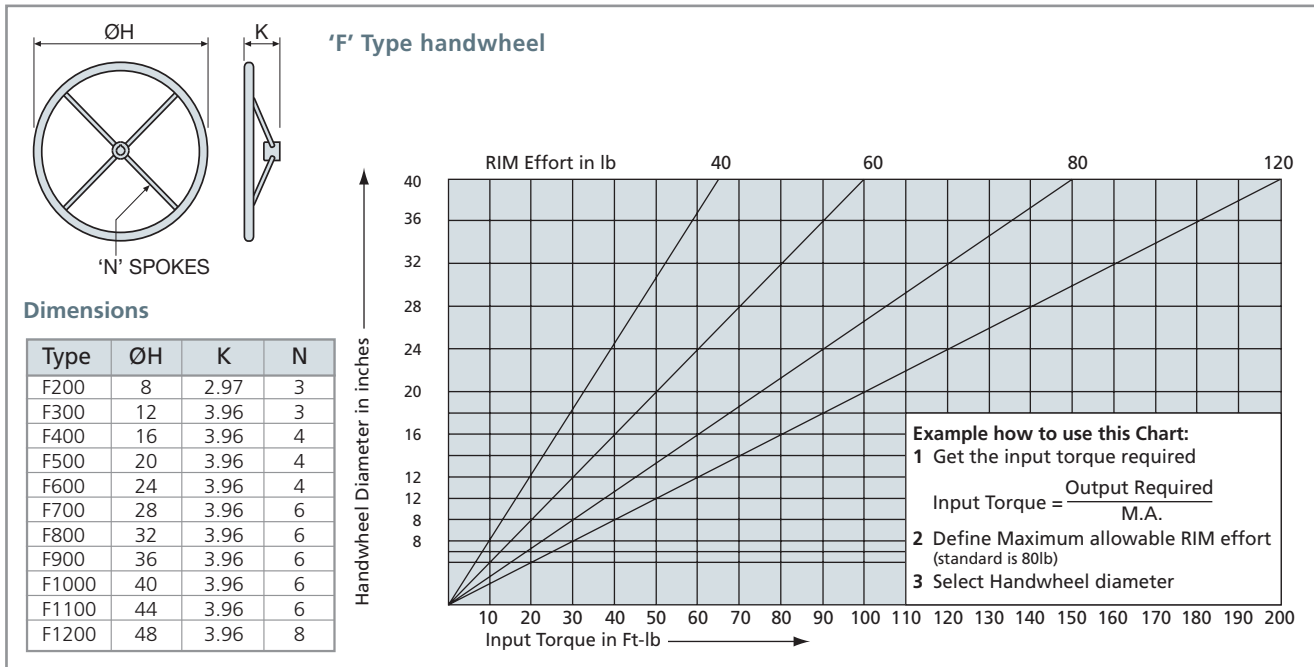

Rotork Gears BV
Nijverheidstraat 25
7581 PV Losser
P.O. Box 98
7580 AB Losser
The Netherlands

tel: +31 (0)53-5388677
fax: +31 (0)53-5383939
email: info@rotorkgears.nl

Rotork Gears UK
Regina House
Ring Road
Bramley, Leeds
West Yorkshire LS13 4ET
England

tel: +44 (0)113 2057276
fax: +44 (0)113 2563556
email: sales@rotorkgears.com

Rotork Gears Americas
1811 Brittmoore
Houston
Texas 77043
USA

tel: +1 713 983 7381
fax: +1 713 856 8022
email: gears@rotorkgears.com

Rotork Gears S.R.L.
via Olona, 65/67
20015 Parabiago (MI)
Italy

tel: +39 0331 552128
fax: +39 0331 553147
email: info@rotorkgears.it

Rotork Gears Shanghai
No. 260 Lian Cao Road
Xin Mei Urban Industrial Park
Min Hang District
Shang Hai 201108
China

tel: 0086-21-64348388
fax: 0086-21-64348366
email: info@rotorkgears.com.cn

A full listing of our worldwide sales and service network is available on our website at

www.rotork.com

Rotork Valvekits
Brookside Way,
Nunn Park,
Huthwaite,
Nottinghamshire, NG17 2NL
England

tel: +44 (0)1623 440211
fax: +44 (0)1623 440214
email: sales@rotorkvalvekits.com

Rotork Gears India
165/166, Bommasandra,
Jigani Link Road,
Kiadb Industrial Area,
Anekal Thaluk, Jigani Hobli,
Bangalore 562106

tel: +91 80 3098 1600
fax: +91 80 3098 1610
email: sales@rotork.co.in

Formerly RGI112E. As part of a process of on-going product development, Rotork reserves the right to amend and change specifications without prior notice. Published data may be subject to change.

For the very latest version release, visit our website at www.rotork.com.

The name Rotork is a registered trademark. Rotork recognizes all registered trademarks. Published and produced in the UK by Rotork Controls Limited. POWTG0411