

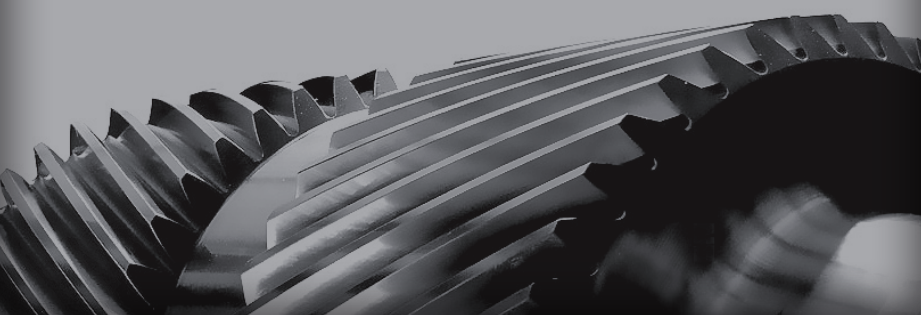

We
move
the
world.

FLENDER
GRAFFENSTADEN



HIGH PERFORMANCE TRANSMISSION FOR ENERGY



Striving for Excellence

Flender-Graffenstaden has developed a tradition in High Performance gear units for the Power Generation and the Oil & Gas industries (speed reducers or increasers, auxiliary and special gearboxes).



”

More than 60 years

“

History

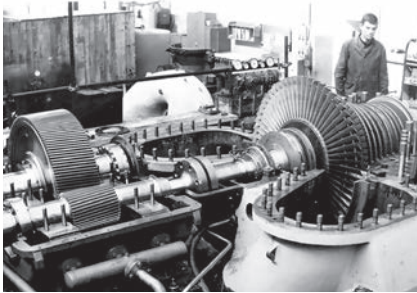

From 1837...

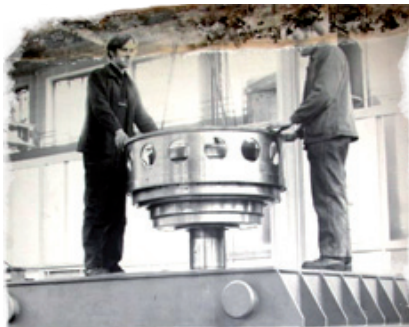

- 1837 > The group "ETABLISSEMENTS DE STRASBOURG" is founded.
- 1841 > Start of machining tools manufacturing.
- 1844 > Production of railway equipment.
- 1872 > The company "SOCIÉTÉ ALSACIENNE DE CONSTRUCTIONS MÉCANIQUES" (SACM) is born.
- 1900 > SACM starts up its own foundry.
- 1904 > Production begins for Ettore Bugatti.
- 1945 > Start up of SACM's own gear division.
- 1949 > Design of the first Turbo Gear.
- 1965 > The Graffenstaden factory becomes CIT-ALCATEL.
- 1984 > Start up of GRAFFENSTADEN ENGRENAGES.
- 1988 > Take-over by the personnel (51 %) and FLENDER (49%).
- 1993 > The FLENDER group takes 100% shares/equity.
- 2005 > SIEMENS AG takes over FLENDER AG including FLENDER-GRAFFENSTADEN S.A.S.



...to the future



”

Story of a Leadership

“

Products



We move, we improve

Based on an experience of more than 13 000 gear units, Flender-Graffenstaden manufactures high efficiency gear units used in all processes in power plants, refineries, offshore and onshore oil and gas installations, petrochemical and industrial process plants around the world.

Flender-Graffenstaden provides turbo parallel shafts and integral gear units with centerline distances ranging from 150 to 1500 mm. Designed to meet specific customer needs, our products can reach rotation speeds up to 40000 rpm and powers up to 100 MW.

In order to transmit these high powers, our case hardened or nitrided teeth are ground with optimized corrections to ensure homogeneous load distribution in operation and provide high reliability during the entire service life of the product. In addition to high precision manufacturing and control standards, each gearbox benefits from a dynamically optimized design of shafts and hydrodynamic bearings. Based on the most modern technologies and latest knowledge in the field of gearboxes, every single gear unit is tested in our facility to demonstrate satisfying operation while highly reliable instrumentation is installed to enable efficient monitoring on-site.



Turbo gear units

Driven by gas turbines, steam turbines or electrical motors, our single or double helical turbo parallel shafts gear units are preferred by professionals in search of high power transmission with very low power losses.

To accommodate the constantly increasing transmitted powers, our R&D experts, manufacturing professionals, quality specialists and design engineers team up to provide qualified design and manufacturing processes, ensuring the production of more powerful but still reliable gear units even at very high powers and high pitchline velocities.

Enclosed in rigid welded steel or cast iron casings, Flender-Graffenstaden gear units can be equipped with a lubricating oil pump or a turning device connected to the free shaft ends of the gear train, according to specific needs.



Integral gear units

For industries looking for high efficiency compression systems, Flender-Graffenstaden provides single or multiple meshing integral gear units using single helical and thrust collar designs. With impellers directly mounted to the high speed shaft, these products form an integral unit with the driven compressors and expanders (integrally geared compressor). These multi-stage gear units can also incorporate other equipment such as electric motors, steam or gas turbines, coolers and turboexpanders. Using the latest knowledge in vibration analysis, journal and thrust bearing technology, sealing systems, FEM calculations for both shafts and casing and the know-how acquired over 60 years of gear manufacturing, Flender-Graffenstaden now provides integral gear units weighting over 50 tons and wheel diameters reaching 3 meters for process plants.

Products

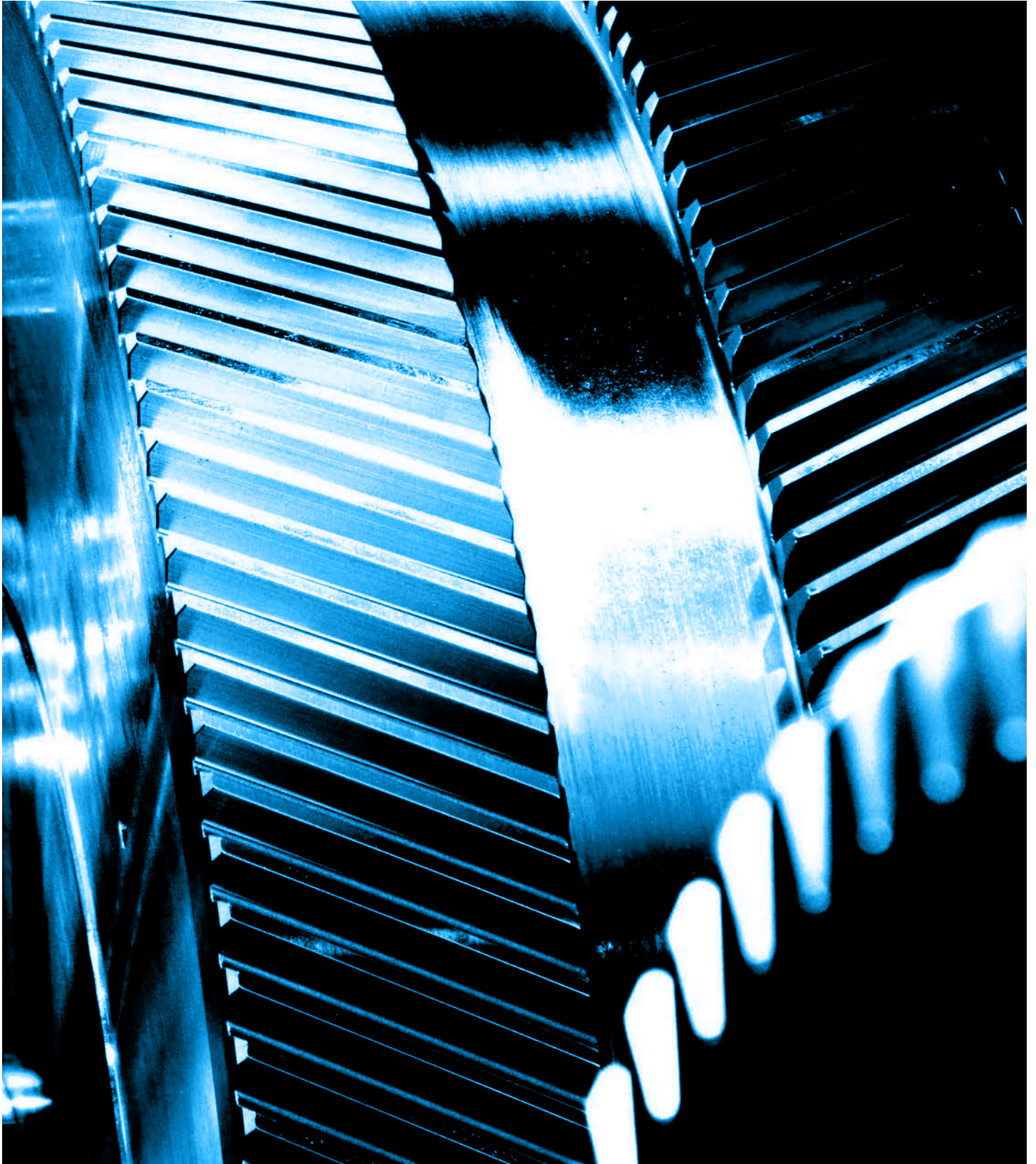

Thousands of References,
a Wealth of Experience !



Oil & Gas

Flender-Graffenstaden High Performance gear units are used in all processes of the Oil & Gas industry throughout the world:

Upstream : FPSO, Platforms, Onshore fields

Midstream : Pipelines, LNG tankers

Downstream : Refineries, LNG plants, GTL plants

Petrochemicals : Fertilisers, PTA plants,

For those applications, gear units are generally designed based on API 613, and are tailored to customer's specifications (end users, engineering contractors and OEM's).

Flender can accommodate mechanical running test at full speed, partial load test or even back to back locked torque test.



Power Generation

Flender-Graffenstaden is recognized as the world leader for Gearboxes used in Industrial Power Generation applications including either gas turbines or steam turbines driving generator.

Load gear units are designed based on API or AGMA standard, and optimized in order to offer the maximum efficiency.



Each product is tested individually on one of our state of the art test bench at full speed condition, partial load test or even back to back locked torque test.

Flender-Graffenstaden also manufactures auxiliary gear units used on some of the most common design of Gas Turbines to start and to drive the auxiliary equipments such as compressors, oil pump etc...

Services



**We serve
a highly
demanding
market**

With an installed fleet of thousands of high speed gearboxes, Flender-Graffenstaden is your alliance partner for the maintenance of your equipment at the highest technological level of performance and durability. With our international presence, we have a team of highly skilled service engineers available when you need them.

Customer support is at the core of Flender-Graffenstaden's philosophy.

Field Service : we support your operations

Our field service team has highly experienced technical engineering Gear Specialists throughout the world and therefore we are available at your site to increase the reliability and performance of your geared equipment. Flender-Graffenstaden will support all installed gearboxes in each country and perform all field services requirements as quickly as possible. Flender-Graffenstaden is unique among full service gear manufacturing companies and provides a global field service support team in partnership with our customers.

Inspection and overhaul

During the lifetime of your gearboxes, field inspections or overhauls are needed as indicated in the Gear Maintenance Manual. To increase the reliability and performance of your equipment we recommend using our

Flender-Graffenstaden gear authorized field service specialists for the following activities:

- Complete disassembling inspection of the gearbox
- Visual check of each part
- Dimensional controls
- Clearance controls
- Re-assembling of the gearbox to Flender-Graffenstaden design standards
- Blue contact tooth pattern check, documented and recorded for future evaluation

Replacement of spare parts

Our field service team is able to install original spare parts and therefore warranty the proper functioning of your equipment to the original internal design specifications of Flender-Graffenstaden.

Emergency service and repair

With many years of experience, the Flender-Graffenstaden authorized field service team can provide the correct solution when emergency field services are needed. This emergency type repair is also fully directed and supported with the backup of all the different gear specialists located at the Flender-Graffenstaden headquarters. This will guarantee:

- High availability and reliability
- High operational safety
- Reactivity and flexibility
- Less stand still time

Technical assistance

The Flender-Graffenstaden field service team can be deputed to site and give you assistance on preventive maintenance, spare parts policy, inventory of spare parts, alignment verification, vibration and noise analysis, oil flow and efficiency documented by our trained specialists



Consulting and Assistance : we deliver the highest quality

We work closely with our customers throughout the entire life cycle of our product, starting from the offer to the after-sales service. In so far as the manufacturer of High Speed Gearing, we are the Best Reference concerning the knowledge of our products: this know-how will consistently represent the best Service Solution to resolve any service issue and to advise our customers.

Services

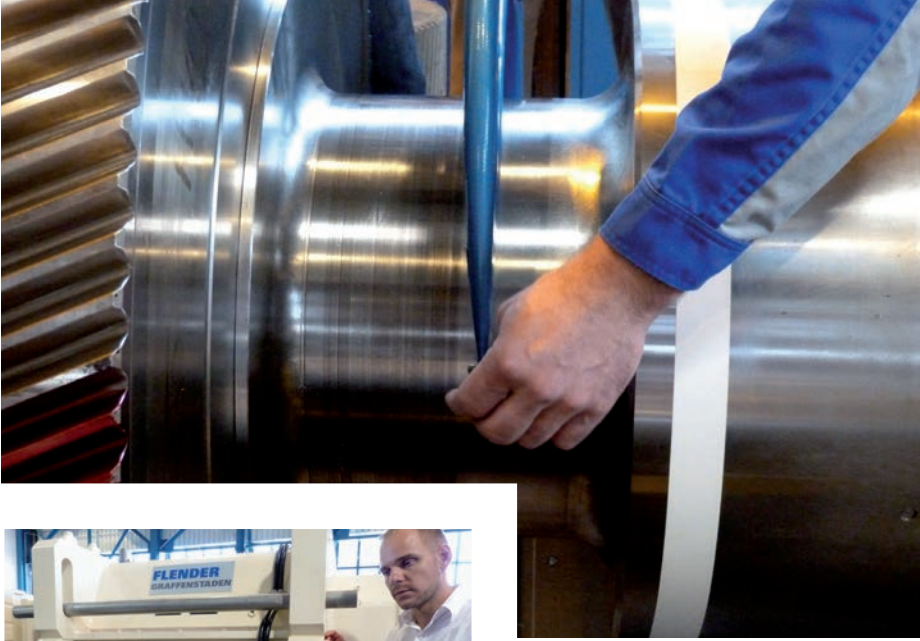

Original spare parts : we inspect, we repair

Flender-Graffenstaden supports the owners of the following brands :
Flender-Graffenstaden,
Graffenstaden Engrenages,
CIT Alcatel,
S.A.C.M. with a complete set of spare parts including :

- Gear set : bull gears and pinion shafts, single helical or double helical gear, pinions teeth are case hardened, bull gear teeth are either, case hardened, nitrided or through hardened, high precision grinding.
- Bearing : oil pressure lubricated 2 or 4 lobes, offset halves, tilting pads bearings, and adjustable bearing for optimized tooth contact pattern.
- Oil seal : labyrinth oil seal
- Accessory : clutch, coupling, oil pump, turning devices...
- Instrumentation : temperature and vibration probes.

Most of those parts are tailor made and not available on the shelf. Only Flender-Graffenstaden genuine parts can guarantee a full interchangeability and trouble free operation.

Retrofit and Revamping : we optimize

As a major piece of rotating equipment, gears are designed for infinite life time and are generally a product with little replacement issues. Flender-Graffenstaden is active in upgrading older gearboxes in order to provide our customers with a best cost /delivery solution and the additional operation time for existing geared equipment.

Our aim is to:

- Provide life cycle extension
- Increase power rating
- Reduce power losses
- Increase the reliability and the availability
- Modernize, improve efficiency and power consumption
- Renovation and upgrading of gearboxes from Flender-Graffenstaden
- Drop in replacement of gearboxes from competitor engineering
- Design replacement gearboxes to fit an existing foundation

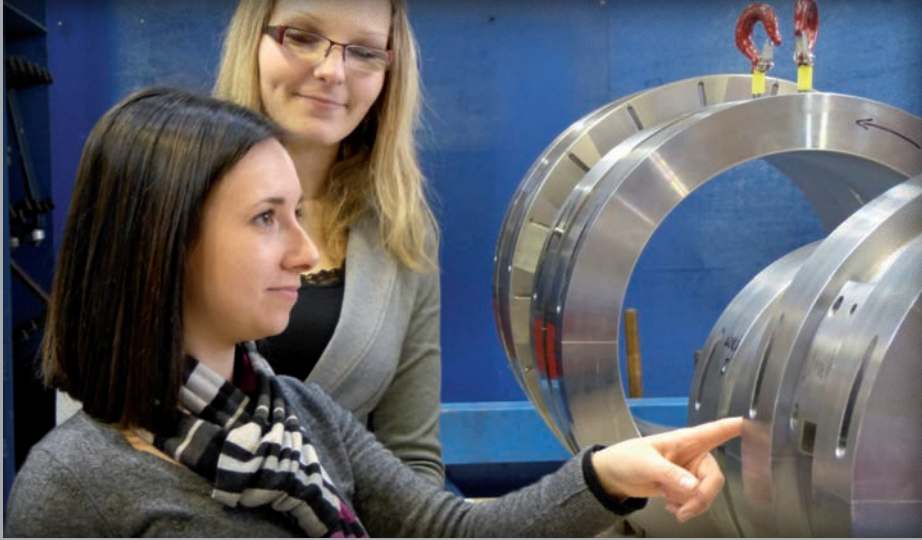

Training : we assist, we train

Another duty of Flender-Graffenstaden consists in supporting and training our customers on our products and their use. For this, we can provide complementary on site trainings: theoretical and practical instructions, aimed at familiarizing our customer with our products. On request from our partners, we welcome their employees within our company.

Training's objectives for our partners are:

- to know and to be able to use products correctly
- to be trained on the products maintenance
- to know what to do in case of a problem
- to understand the manufacturing process

Training's objectives for Flender-Graffenstaden:

- to get closer to our customers
- to get enriched from remarks and experiences from our customers
- ensure a trusting relationship and a total sharing of information
- improve our products

Expertise : we are quick and flexible

Flender-Graffenstaden can offer complete expertise and root cause analysis for failures at site.



Service and Spare parts for non Flender- Graffenstaden gearboxes : we offer a global service

Flender-Graffenstaden can support non Flender-Graffenstaden products with our dedicated engineering team through reverse engineering, drop-in replacement as well as repairs and upgrades to meet current API requirements.



Quality



”

We deliver the highest quality

“



Customer satisfaction and the highest service quality are our top priorities

Flender-Graffenstaden designs, manufactures, markets and maintains speed reducers and increasers for the global energy, oil and chemical industries. Today you, our customer, are looking for optimised technical solutions at competitive prices.

We aim to build and sustain long-term partnership relationships based on trust.

We are committed to improving continuously the quality, costs and timeframes of our processes and



organisation in order to meet your requirements and expectations.

Planning, developing, verifying and acting are the keywords in our ongoing improvement initiative. This is why we grant the highest importance to achieving and maintaining ISO 9001 certification and we encourage all



our staff to develop real "quality awareness".

All Flender-Graffenstaden employees are fully engaged and involved in implementing the company's quality targets to ensure that the quality of our work meets with total customer satisfaction.



Philosophy

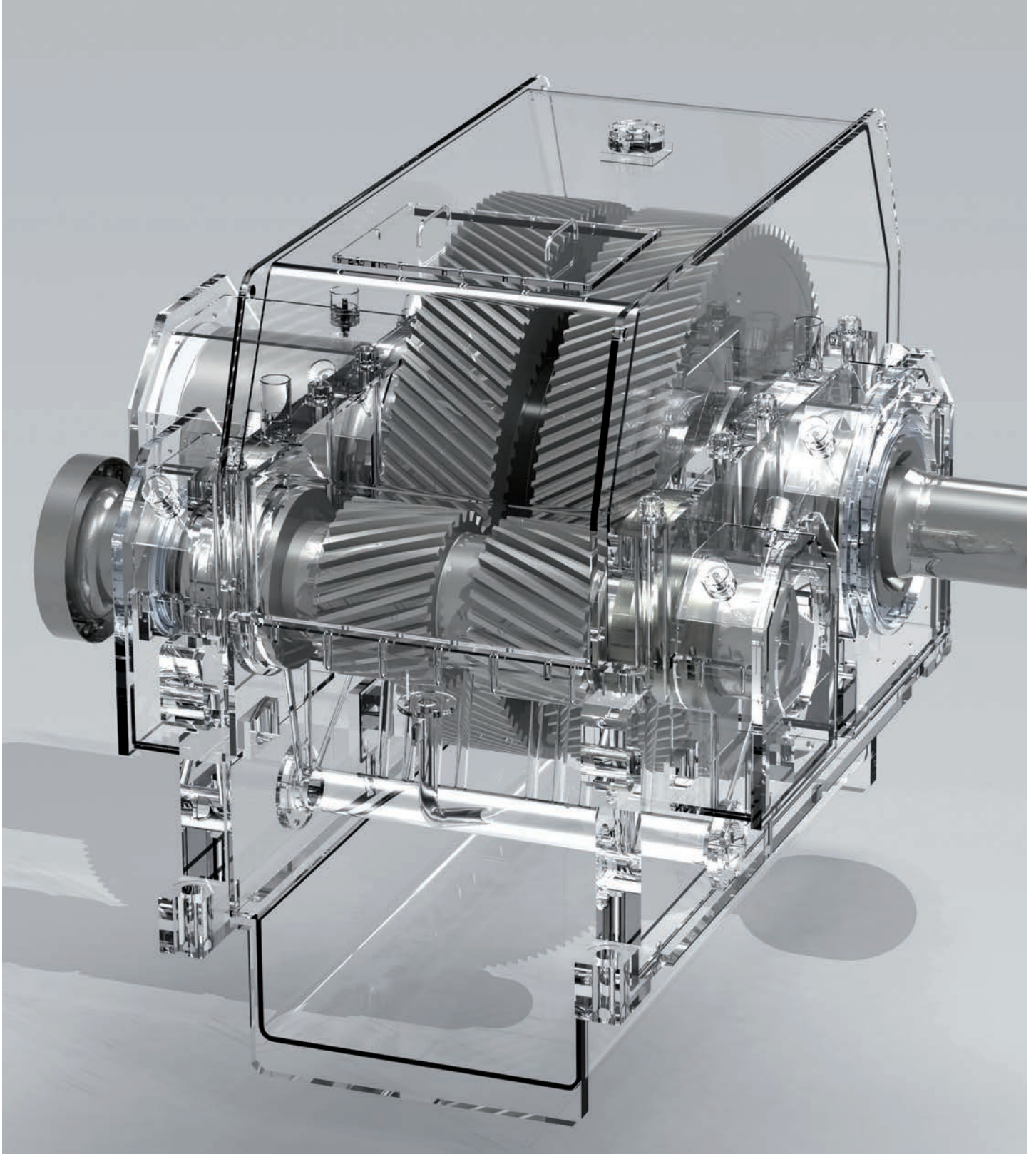

Mission

Our Mission is to develop and manufacture the heart of high performance power transmission to serve energy needs.

Vision

Flender-Graffenstaden, considered as the number One to meet the requirements of its customers (OEM and Final) who are worldwide leaders in the sectors of energy, settled for permanent goal to be always leader in the sector of turbo gears for industry, production of energy and the oil and gas sectors.

By their admitted know-how, their ingenuity, their motivation and their dynamism, all teams are the guarantors of highest quality, of reliability and of continuous innovation and improvement of their products by bringing technological solutions adapted to the specific needs of our clients, as well as distribution and service capacities

Flender-Graffenstaden is a responsible corporate citizen of the world, putting into practice the highest performance and the highest ethical standards, and is recognized by its clients and suppliers as an innovative leader offering superior quality products, customized solutions and progressive customer service.

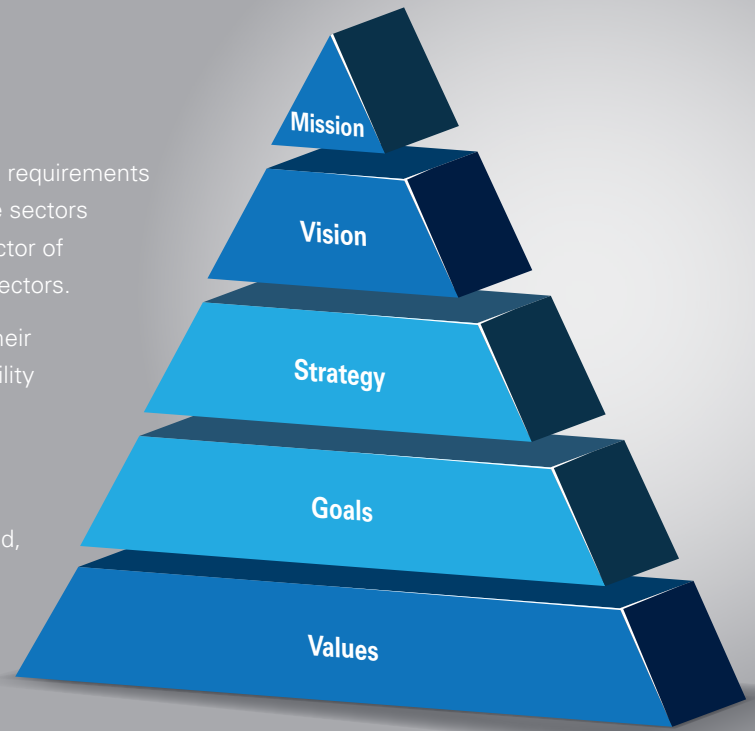

Value

Responsability is the guideline of all our decisions

Flender-Graffenstaden is determined to meet - and wherever possible, exceed – all legal and ethincal requirements. We encourage all our business partners and suppliers to adopt a similar standard of ethical behaviour.

Our principles:

- We obey the law
- We operate with a high level of integrity in our dealings with people, internally and externally, respecting the dignity of all people.
- We conduct business in a truthful and transparent manner
- We are fair in our relationships with competitors and stakeholders
- We honor commitments
- We respect property
- We are committed to good corporate citizenship
- We are fully engaged and empowered to achieve the best results

Our Innovation is to change the world

We are ingenious, visionary and pioneers. We measure the success of our innovations by our customer's success.

Our principles:

- We are creative, ingenious and visionary
- We understand our customers real needs and create innovative products, systems, process, solutions and services which give them a unique competitive edge and allow them to be market leaders
- We keep the key patents and are firmly positioned on established technologies which will transform the world of tomorrow

Excellence at each moment !

We stand beside our customers in the search for perfect quality, coming up with solutions that exceed expectations. Excellence demands we define a path of continuous improvement and constantly challenging existing processes. Excellence also means attracting the best talents in the marketplace and giving them the skills and opportunities they need to become high-achievers.

Our principles:

- We deeply understand our customers needs and challenges
- We interact in an efficient and pragmatic way between R&D and Sales
- We are passionate
- We always strive for improvements and perfect quality
- We embrace change to ensure we are competitive in the future

RESPONSABILITY

INNOVATION

EXCELLENCE

Philosophy

Lean Management

We are one of the market leaders and intend to increase our competitive edge. The Lean Thinking has been adopted a long time ago and is today a program which facilitates continuous improvement in our performance and allows us to maximize our strengths.

The Lean Thinking Program has proven to be successful and uses established methods that can be easily and effectively implemented by every single employee.

The advantages are obvious: Lean Production that is systematically oriented towards the customer - with world-class product quality, flexibility and delivery reliability. It offers a standardized frame to optimize all necessary fields of action.

Everything is in our hands. With the help of the Lean Philosophy, we can become even more efficient and productive, so that every one can say: «I am proud to produce high quality by setting world class standards.»



Innovation

In addition to Responsibility and Product Excellence, Innovation is another driving force of our organization which shows up in the Products and Services we offer to our customers. In all our developments and engineering activities we combine best practices, return of experience and innovation to ensure safety and reliability of our products. This balance allows us to provide our customers with world class gearboxes. Our continuous efforts to make improvements ensure that information received from both the production and service departments is directly fed back into our engineering processes. Our lean approach, contribute to delivering continuously improved products.

The use of state of the art design methodologies such as FEM, dynamic analysis and sophisticated gear and bearing calculations enables us to improve the predictability and the understanding of the behaviour of our machines. It also allows us to transfer improvements in terms of Power density and efficiency to our customers.

Last but not least, Flender-Graffenstaden's involvement in domestic and international symposium associated to our participation in research activities enables us to transfer knowledge to our products. It does reflect our innovative spirit.



Compliance

Flender-Graffenstaden Compliance System : to prevent effectively compliance violations, we have developed a comprehensive set of rules and regulations applicable to all employees and managers. Our compliance rules provide

clear guidance to all employees and managers concerning the behavior that is expected of them. We have developed effective processes and instruments to integrate these rules directly into our business

processes, in order to support appropriate behavior.

Only clean business is our business.



Health and Safety

Our objective regarding health and safety

- Protect the physical integrity of our employees by :
- improving the working conditions
 - reducing the risks of accidents



Environment protection

Our objectives regarding environment

Protect the environment by reducing the impact on :

- natural resources
- energy consumption
- chemicals consumption
- air emissions
- waste production
- rejections (discharges)
- ground water

Industrial risks

Our objectives regarding industrial risk

Protect our neighborhood by :

- eliminating the risks of leakage or pollution
- testing and updating regularly our emergency plan

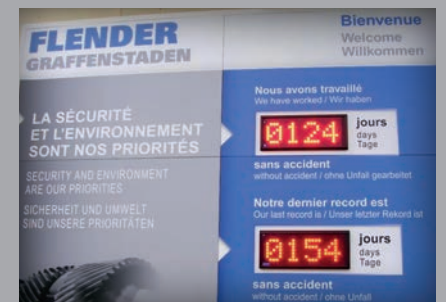

FLENDER **GRAFFENSTADEN**

1, rue du Vieux Moulin
BP 10063 F - 67400
ILLKIRCH GRAFFENSTADEN Cedex
Phone +33 (0) 3 88 67 60 00
Fax +33 (0) 3 88 67 06 17

www.flender-graff.com

