

ISO 9001:2008 by L.R.  
PED DIR. 97/23/EC by L.R.  
ATEX DIR. 94/9/EC by B.V.  
FIRE SAFE EXECUTION by L.R.  
ISO 15848 by TÜV  
ANTISTATIC DEVICE by L.R.  
FIRE SAFE TESTED ISO 10497 by L.R.

TYPE  
**FT6**  
PN 25 ÷ 63

NORME E DIRETTIVE APPLICATE DISPONIBILI AL SEGUENTE LINK:  
STANDARD AND DIRECTIVE APPLIED AVAILABLE AT FOLLOWING LINK:  
[http://www.adlerspa.com/pdf/NORME\\_ADLER.pdf](http://www.adlerspa.com/pdf/NORME_ADLER.pdf)

## VALVOLE A SFERA "3 VIE" PASSAGGIO TOTALE 90°

ISO nbr° LRC 0160281 QMS issued by L.R.Q.A. PED nbr° COV 0212112/01 issued by L.R.V.  
ATEX nbr° 40.2003.4392 issued by B.V. ISO 15848 nbr° I-148466/1-/2 issued by TÜV

On request  
S.I.L. 3  
According to IEC 61508

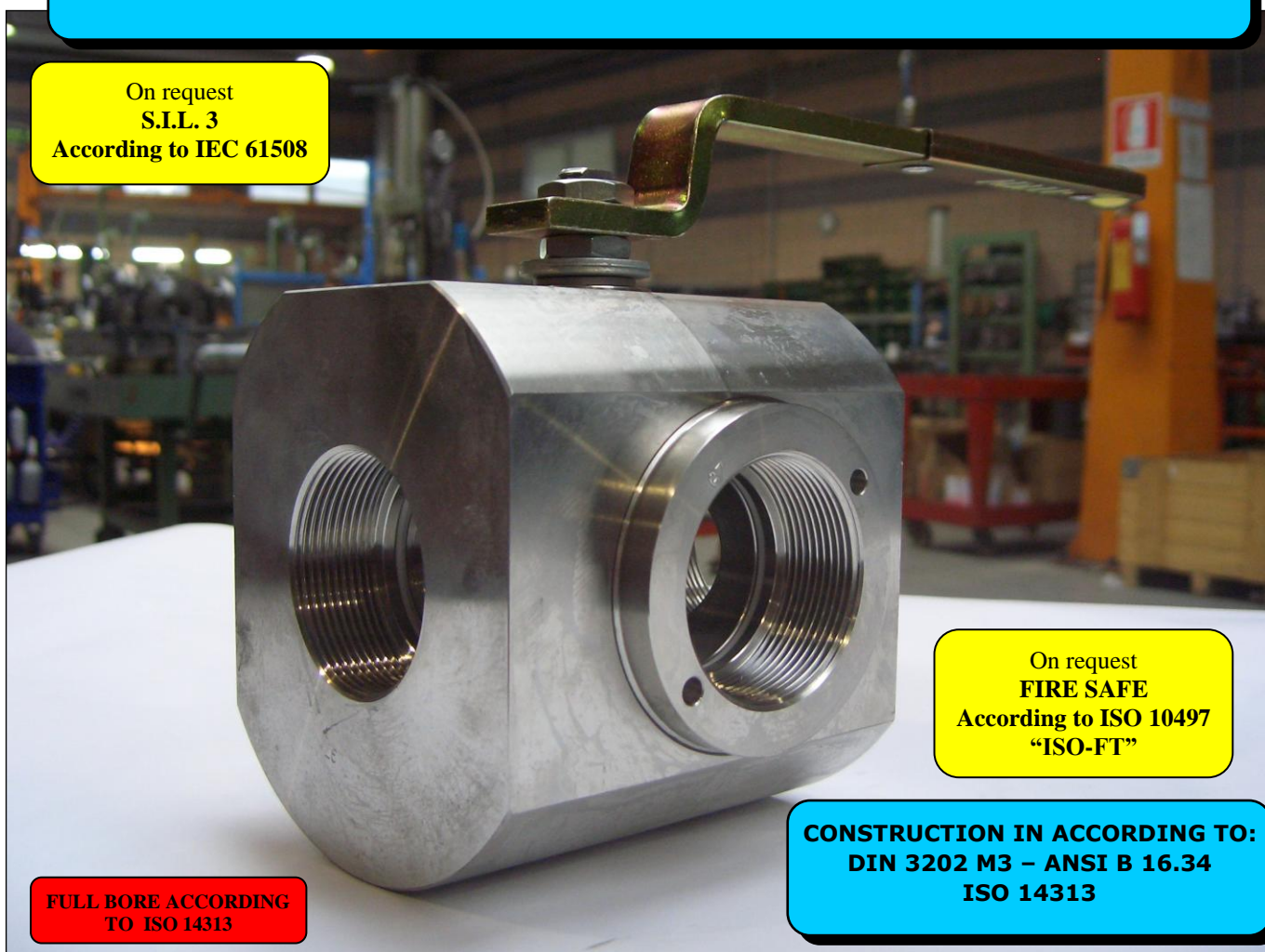

On request  
FIRE SAFE  
According to ISO 10497  
"ISO-FT"

CONSTRUCTION IN ACCORDING TO:  
DIN 3202 M3 - ANSI B 16.34  
ISO 14313

FULL BORE ACCORDING  
TO ISO 14313

**BALL VALVES "3 WAY" FULL BORE 90°**  
**ROBINETS A BOISSEAU SPHERIQUE**  
**"3 VOIES" PASSAGE INTEGRAL 90°**  
**KUGELHÄHNE "3 WEGE"**  
**VOLLER DURCHGANG 90°**

WEB SITE: [WWW.ADLERSPA.COM](http://WWW.ADLERSPA.COM)

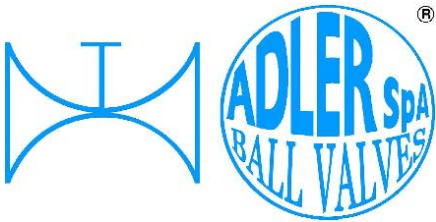

ISO 9001:2008 by L.R.  
 PED DIR. 97/23/EC by L.R.  
 ATEX DIR. 94/9/EC by B.V.  
 FIRE SAFE EXECUTION by L.R.  
 ISO 15848 by TÜV  
 ANTISTATIC DEVICE by L.R.  
 FIRE SAFE TESTED ISO 10497 by L.R.

TYPE  
**FT6**  
 PN 25 ÷ 63

**VALVOLA A SFERA "3 VIE" PASSAGGIO TOTALE 90°**  
**BALL VALVES "3 WAY" FULL BORE 90°**  
**ROBINETS A BOISSEAU SPHERIQUE "3 VOIES" PASSAGE INTEGRAL 90°**  
**KUGELHÄHNE "3 WEGE" VOLLER DURCHGANG 90°**

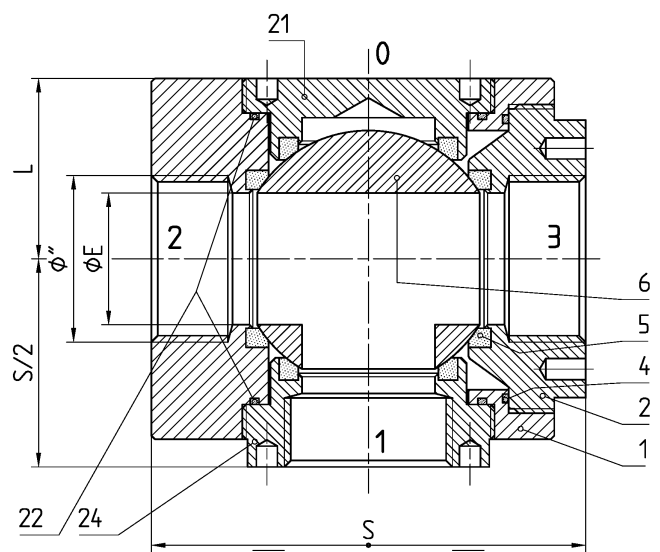
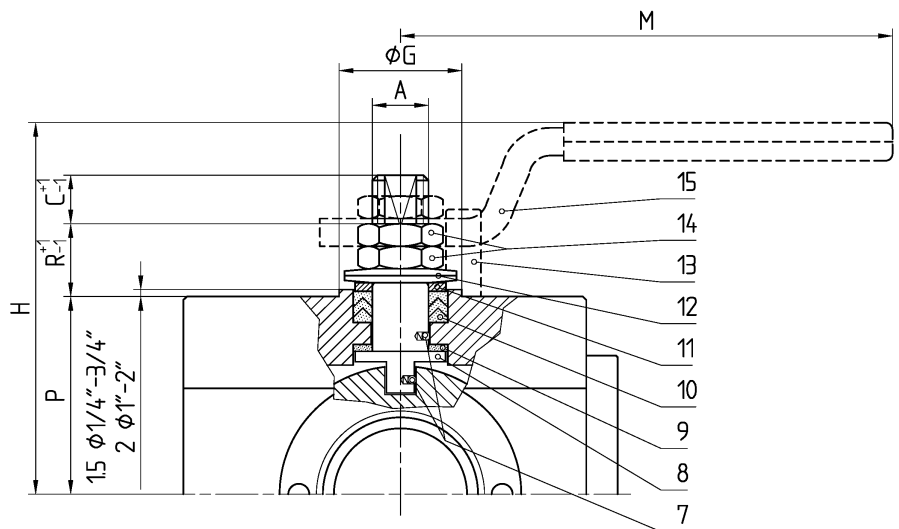

**CONSTRUCTION IN ACCORDING TO:**  
**DIN 3202 M3 - ANSI B16.34**  
**ISO 14313**

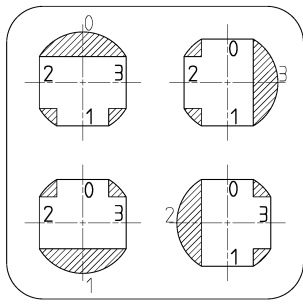
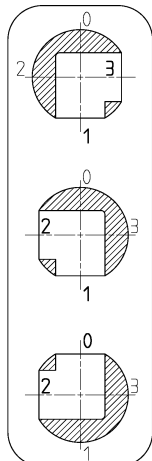

POSIZIONI OTTENIBILI  
 OBTAINABLE POSITIONS  
 POSITIONS OBTENIBLES  
 MÖGLICHE STELLUNGEN

• ACCOPPIAMENTO VALVOLA  
 ATTUATORE  
 • CONNECTION VALVE  
 ACTUATOR  
 • ACCOUPLEMENT ROBINET-  
 ACTIONNEUR  
 • ZUSAMMENBAU KUGELHAHN  
 ANTRIEB  
**ISO-5211**

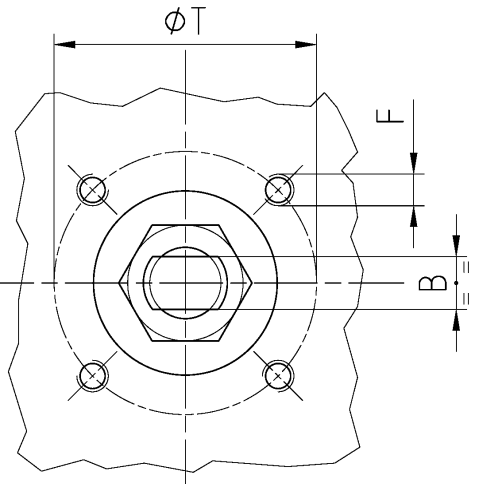

N.	DESCRIZIONE DESCRIPTION BESCHREIBUNG	MATERIALI MATERIALS MATERIAUX WERKSTOFFE
1	CORPO BODY CORPS KÖRPER	ASTM A105 ASTM A 182 F316- A479 S31600
2	GHIERA INSERT EMBOUT GEWINDEDRUCKRING	ASTM A105 ASTM A 182 F316- A479 S31600
4*	ANELLO SEAL ANNEAU DICHTUNGSRING	P.T.F.E.
5*	SEDE SEAT SIEGE SITZRING	P.T.F.E.
6	SFERA BALL BOULE KUGEL	ASTM A182 F304-A479 S30400 ASTM A351 CF8 ≥ Ø 1½"
		ASTM A182 F316-A479 S31600 ASTM A351 CF8M
7	DISPOSITIVO ANTISTATICO ANTISTATIC DEVICE CONTACT ANTISTATIQUE ANTISTATIK VORRICHTUNG	ASTM A479 S31600
8	STELO STEM TIGE SPINDEL	ASTM A182 F304 A479 S30400 ≥ Ø 1½"
		ASTM A182 F316 A479 S31600
9*	BUSSOLA STEM SEAL JOINT TIGE UNTERE SPINDELABDICHTUNG	P.T.F.E.
10*	PACCO A "V" CHEVRON RINGS JOINT A "V" 3 FACHE DACHMANSCHETTE	P.T.F.E. / GRAFITE P.T.F.E. / GRAPHITE P.T.F.E. / GRAPHITE P.T.F.E. / GRAPHIT

N.	DESCRIZIONE DESCRIPTION BESCHREIBUNG	MATERIALI MATERIALS MATERIAUX WERKSTOFFE
11	PREMIBUSSOLA PRESSING BUSH PRESSE RONDELLE STOPFBUCHSDRUCKRING	ASTM A479 S31600
12	MOLLE A TAZZA SPRING WASHERS RONDELLES BELLEVILLE TELLERFEDERN	C72/50Cr V4 ZINCATO - GALVANIZED - ZINGUE - VERZINKT X5CrNi17.7 or X12CrNi17.7 ON REQUEST
13	VITE DI FERMO E FERMO PIN AND STOP PIN PLOT ET PLOT D'ARRET ANSCHLAGBOLZEN	UNI 3740 8.8 ZINCATO - GALVANIZED - ZINGUE - VERZINKT UNI 3951 A2-70 ON REQUEST
14	DADO - CONTRODADO NUT - LOCK NUT ECROU - CONTRE-ECROU MUTTER - KONTERMUTTER	UNI 3740 - 6S ZINCATO - GALVANIZED - ZINGUE - VERZINKT ASTM A479 304 ON REQUEST
15	UNI 5946 Fe 37 ASTM A479 304	UNI 5946 Fe 37 ZINCATO - GALVANIZED - ZINGUE - VERZINKT ASTM A479 304 ON REQUEST
21	GHIERA INSERT EMBOUT GEWINDEDRUCKRING	ASTM A105 ASTM A 182 F316- A479 S31600
22*	ANELLO SEAL ANNEAU DICHTUNGSRING	P.T.F.E.
24	GHIERA INSERT EMBOUT GEWINDEDRUCKRING	ASTM A105 ASTM A 182 F316- A479 S31600

\* RICAMBI CONSIGLIATI - RECOMMENDED SPARE PARTS - PIECES DE RECHANGE CONSEILLEES - ERSATZTEIL EMPFEHLUNG

## DIMENSIONI - DIMENSION - DIMENSIONS - ABMESSUNGEN

Ø"	1/4"	3/8"	1/2"	3/4"	1"	1 1/4"	1 1/2"	2"	2 1/2"	3"	4"	5"	6"	8"
<b>A</b>	8	8	10	10	12	12	16	16						
<b>B</b>	5	5	6	6	8	8	10	12						
<b>C</b>	6	6	7	7	10	10	15	15						
<b>ØE</b>	10	10	15	19	25	30	38	51						
<b>F</b>	M5	M5	M5	M5	M5	M5	M6	M6						
<b>ISO</b>	F03	F03	F03	F03	F03	F03	F05	F05						
<b>G</b>	25	25	25	25	25	25	35	35						
<b>H</b>	50	50	70	74	90	97	113	123						
<b>L</b>	24,5	24,5	30	32,5	39	43,5	51,5	60,5						
<b>M</b>	120	120	145	145	185	185	280	280						
<b>P</b>	21,5	21,5	30	34,5	46	51	57	67						
<b>R</b>	12	12	14	14	17	17	20	20						
<b>S</b>	60	60	75	80	90	110	120	140						
<b>T</b>	36	36	36	36	36	36	50	50						
<b>PN</b>	63	63	63	40	40	40	25	25						
<b>~Kg</b>	1,5	1,5	2,3	3,1	4,4	6,2	9,5	15	CARBON STEEL - STAINLESS STEEL					
<b>~Kg</b>			2		4		8,8		STAINLESS STEEL					

- DATI E CARATTERISTICHE SOGGETTI A VARIAZIONI SENZA PREAVVISO
- SPECIFICATIONS SUBJECT TO MODIFICATION WITHOUT PRIOR NOTICE
- TOUS DROITS DE MODIFICATION RESERVES
- KONSTRUKTIONSÄNDERUNGEN VORBEHALTEN

EXECUTION 17

EXECUTION 18

Ø 1/4"÷3/8" SEAT IN R.P.T.F.E.



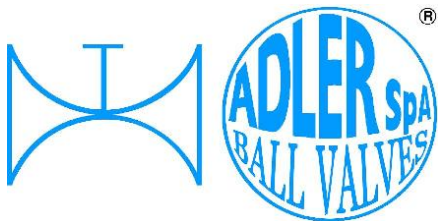

ISO 9001:2008 by L.R.  
 PED DIR. 97/23/EC by L.R.  
 ATEX DIR. 94/9/EC by B.V.  
 FIRE SAFE EXECUTION by L.R.  
 ISO 15848 by TÜV  
 ANTISTATIC DEVICE by L.R.  
 FIRE SAFE TESTED ISO 10497 by L.R.

TYPE  
**FT6**  
 PN 25 ÷ 63

VALVOLE A SFERA "3 VIE" PASSAGGIO TOTALE 90°  
 BALL VALVES "3 VIE" FULL BORE 90°

ROBINETS A BOISSEAU SPHERIQUE "3 VOIES" PASSAGE INTEGRAL 90°  
 KUGELHÄHNE "3 WEGE" VOLLER DURCHGANG 90°

• ESECUZIONI • EXECUTIONS • EXECUTIONS • AUSFÜHRUNGEN



EXECUTION 4 - 12

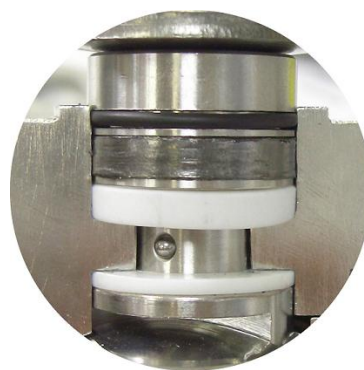
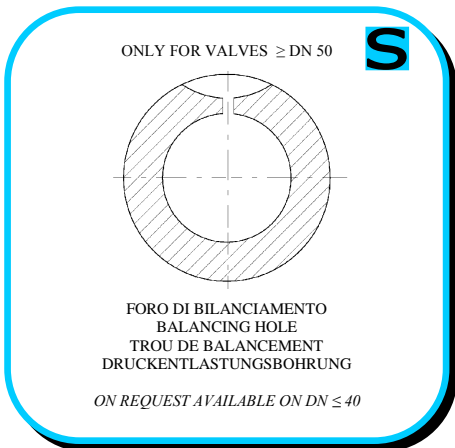

EXECUTION 6 - 16

**S** STANDARD

**O** OPTIONAL

**1** **S**

SEE TABLE 23  
 FOR TYPE  
 OF THREAD

**2** **S** INDICATORE DI FLUSSO  
 FLOW INDICATOR

**ADLER**

UNA GAMMA COMPLETA  
 PRIVILEGIANDO LA QUALITÀ\*

A COMPLETE RANGE PRIVILEGING  
 THE QUALITY

**4** **S**

-STELO ANTI ESPULSIONE -ANTI BLOW OUT STEM  
 -TIGE ANTIEXPULSION -AUSBLASGESICHERTE WELLE

-PACCO A "V" -CHEVRON RINGS  
 -JOINT A "V" -3 FACHE DACHMANSCHETE  
 ANTISTATIC DEVICE ANTISTATIK VORRICHTUNG  
 BS 5146

**5** **O**

103 (1/4" - 3/4")  
 145 (1" - 1 1/4")  
 69 (1/4" - 3/4")  
 79 (1" - 1 1/4")  
 57

-MANIGLIA OVALE - OVAL HANDLE  
 -LEVIER OVAL -HANDHEBEL IN OVALFORM

**6** **O** BREVETTO - PATENTED  
 00219688

FKM (VITON)  
 Ø 1/2" ÷ 2"

-"O" RING STELO "O" RING ON STEM  
 -TIGE AVEC "O" RING  
 -"O" RING IM SPINDELBEREICH

FT6/12 RIPRODUZIONE VIETATA - COPYRIGHT



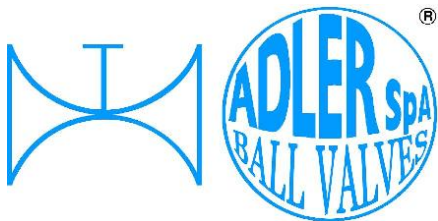

ISO 9001:2008 by L.R.  
 PED DIR. 97/23/EC by L.R.  
 ATEX DIR. 94/9/EC by B.V.  
 FIRE SAFE EXECUTION by L.R.  
 ISO 15848 by TÜV  
 ANTISTATIC DEVICE by L.R.  
 FIRE SAFE TESTED ISO 10497 by L.R.

TYPE  
**FT6**  
 PN 25 ÷ 63

VALVOLE A SFERA "3 VIE" PASSAGGIO TOTALE 90°  
 BALL VALVES "3 VIE" FULL BORE 90°

ROBINETS A BOISSEAU SPHERIQUE "3 VOIES" PASSAGE INTEGRAL 90°  
 KUGELHÄHNE "3 WEGE" VOLLER DURCHGANG 90°

• ESECUZIONI • EXECUTIONS • EXECUTIONS • BESCHREIBUNG

**7** **O**

-PROLUNGA STELO -STEM EXTENSION  
 -TIGE PROLONGEE -SPINDELVERLÄNGERUNG

**8** **O**

-PARTICOLARI INOX  
 -STAINLESS STEEL DETAILS  
 -ACCESSOIRES EN INOX  
 -EDELSTAHLTEILE

**9** **S**

-ATTACCO "ISO" -"ISO" CONNECTIONS  
 -SYSTEM "ISO" -ANSCHLSS "ISO"

**10** **S**

-SFERA CONTENUTA -CONTENTS BALL  
 -BOULE CONTENUE  
 -NICHT RAUSRAGENDE KUGEL

**AQUILA - EAGLE - AIGLE  
 ADLER**

**12** **O**

**FIRE SAFE  
 ISO 10497 "ISO-FT"  
 (BS 6755 / API 607)**

**13** **S**

-ANELLO CONTENUTO -CONTAINED SEAL  
 -ANNEAU CONTENU -DICHRING GEKAMMERT  
 -GHIERA A BATTUTA -METAL BEATING RING  
 -EMBOUT AVEC BATTUE MECANIQUE  
 -METALLISCHER ANSCHLAG DES  
 GEWINDEDRUCKRINGS

**14** **O**

-FORO DI SCARICO NELLA SFERA  
 -OVERPRESSURE HOLE INTO BALL  
 -TROUGH DECOMPRESSION DANS LA BOULE  
 -ENTLASTUNGSBOHRUNG IN DER KUGEL

**15** **O**

-SERVIZIO CRIOGENICO - CRYOGENIC SERVICE  
 -SERVICE CRYOGÉNIQUE  
 -TIEFTEMPERATUR SERVICE

**CERTIFY ISO 9001:2008**

**17** **S**

VALVOLE IN ACCIAIO INOX  
 STAINLESS STEEL BALL VALVES  
 Ø 1/4" - 3/8" - 3/4" - 1 1/4" - 2"

VALVOLE IN ACCIAIO AL CARBONIO  
 CARBON STEEL BALL VALVES

**18** **S**

Ø 1/2" - 1" - 1 1/2"

VALVOLE IN ACCIAIO INOX  
 STAINLESS STEEL BALL VALVES

**IN ACCORDANCE TO  
ISO 7-1 – 1994**

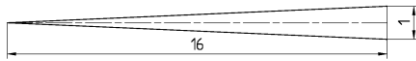

H= 0.960 237 P  
h= 0.640 327 P  
r= 0.137 278 P

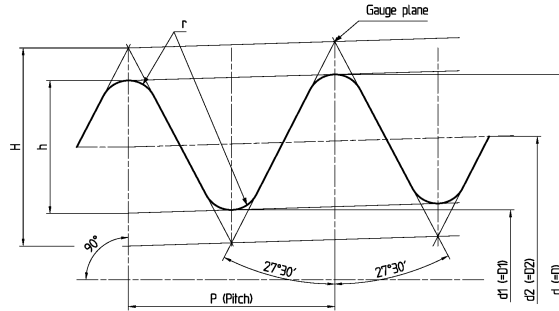

1 Designation of thread size	2 Number of threads in 25.4 mm	3 Pitch P	4 Height of thread h	5 Diameters of gauges plane			6 Gauges length (external threads)					7 Tolerance on position of gauge plan on internal thread		8 Length of useful external thread not less than			9 Fitting allowance		20 Diameter tolerance on parallel internal threads
				Major d	Pitch d <sub>2</sub>	Minor d <sub>1</sub>	Nominal	Tolerance ±t <sub>1</sub> /2		Max.	Min.	Tolerance ±t <sub>2</sub> /2		For nominal gauge length	For maximum gauge length	For minimum gauge length	2)	Turns of thread	
								2)	Turns of thread			2)	Turns of thread						
¼	19	1,337	0,856	13,15	12,30	11,44	6	1,3	1	7,3	4,7	1,7	1 ¼	9,7	11	8,4	3,7	2 ¾	±0,104
3/8	19	1,337	0,856	16,66	15,80	14,95	6,4	1,3	1	7,7	5,1	1,7	1 ¼	10,1	11,4	8,8	3,7	2 ¾	±0,104
½	14	1,814	1,162	20,95	19,79	18,63	8,2	1,8	1	10	6,4	2,3	1 ¼	13,2	15	11,4	5	2 ¾	±0,142
¾	14	1,814	1,162	26,44	25,27	24,11	9,5	1,8	1	11,3	7,7	2,3	1 ¼	14,5	16,3	12,7	5	2 ¾	±0,142
1	11	2,309	1,479	33,24	31,77	30,29	10,4	2,3	1	12,7	8,1	2,9	1 ¼	16,8	19,1	14,5	6,4	2 ¾	±0,180
1 ¼	11	2,309	1,479	41,91	40,43	38,95	12,7	2,3	1	15	10,4	2,9	1 ¼	19,1	21,4	16,8	6,4	2 ¾	±0,180
1 ½	11	2,309	1,479	47,80	46,32	44,84	12,7	2,3	1	15	10,4	2,9	1 ¼	19,1	21,4	16,8	6,4	2 ¾	±0,180
2	11	2,309	1,479	59,61	58,13	56,65	15,9	2,3	1	18,2	13,6	2,9	1 ¼	23,4	25,7	21,1	7,5	3 ¼	±0,180

**IN ACCORDANCE TO  
ANSI B1.20.1 – 1983**

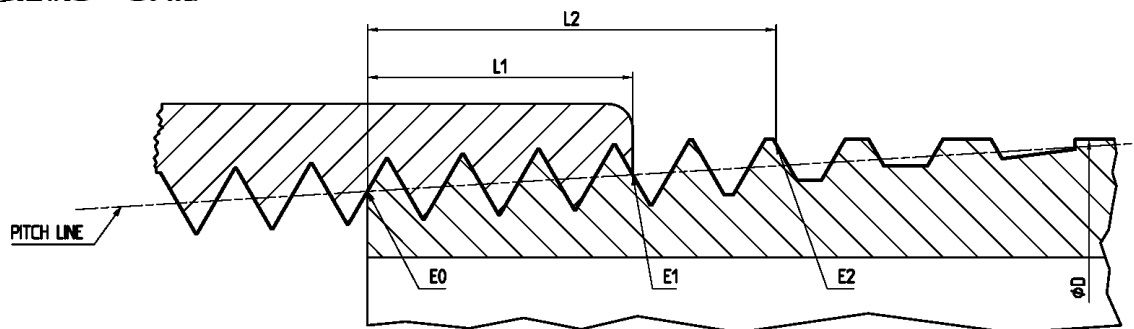

1 Nominal Pipe Size	2 O.D. of Pipe (D)	3 Threads/inch (n)	4 Pitch of threads (P)	5 Pitch diam. at beginning of external thread (E <sub>0</sub> )	6 Handtight engagement			7 Effective thread, external		
					Length <sup>2</sup> (L <sub>1</sub> )		Diam. <sup>3</sup> (E <sub>1</sub> )	Length <sup>4</sup> (L <sub>2</sub> )		Diam. <sup>5</sup> (E <sub>2</sub> )
					inch	threads		inch	threads	
¼	0,540	18	0,05556	0,47739	0,2278	4,1	0,49163	0,4018	723	0,50250
3/8	0,675	18	0,05556	0,61201	0,240	4,32	0,32701	0,4078	734	0,63750
½	0,840	14	0,07143	0,75843	0,320	4,48	0,77843	0,5337	747	0,79179
¾	1,050	14	0,07143	0,96768	0,339	4,75	0,98887	0,5457	764	1,00179
1	1,315	11,5	0,0896	1,21363	0,400	4,6	1,23863	0,6828	785	1,25630
1 ¼	1,660	11,5	0,0896	1,55713	0,420	4,83	1,58338	0,7068	813	1,60130
1 ½	1,900	11,5	0,0896	1,79609	0,420	4,83	1,82237	0,7235	832	1,84130
2	2,375	11,5	0,0896	2,26902	0,436	5,01	2,29627	0,7565	870	2,31630