



# HEIDENHAIN



## Linear Encoders

For Numerically Controlled  
Machine Tools

July 2016



Further information is available on the Internet at [www.heidenhain.de](http://www.heidenhain.de) as well as upon request.

Product brochures:

- Exposed Linear Encoders
- Angle Encoders With Integral Bearing
- Angle encoders without integral bearing
- Rotary Encoders
- HEIDENHAIN Subsequent Electronics
- HEIDENHAIN Controls
- Measuring Devices For Machine Tool Inspection and Acceptance Testing

Technical information brochures:



- Interfaces of HEIDENHAIN Encoders
- Accuracy of Feed Axes
- Safety-Related Position Measuring Systems
- EnDat 2.2—Bidirectional Interface for Position Encoders
- Encoders for Direct Drives

*This catalog supersedes all previous editions, which thereby become invalid. The basis for ordering from HEIDENHAIN is always the catalog edition valid when the contract is made.*

*Standards (ISO, EN, etc.) apply only where explicitly stated in the catalog.*

Comprehensive descriptions of all available interfaces as well as general electrical information are included in the *Interfaces of HEIDENHAIN Encoders* brochure.

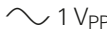
# Contents

<b>Overview</b>		
	<b>Linear encoders</b>	<b>4</b>
	<b>Selection guide</b>	<b>6</b>
<b>Technical features and mounting information</b>		
	<b>Measuring principles</b>	<b>8</b>
	Measuring standard	<b>8</b>
	Absolute measuring method	<b>8</b>
	Incremental measuring method	<b>9</b>
	Photoelectric Scanning Principle	<b>10</b>
	<b>Measuring accuracy</b>	<b>12</b>
	<b>Mechanical design types and mounting guidelines</b>	<b>14</b>
	<b>General mechanical information</b>	<b>18</b>
	<b>Functional safety</b>	<b>20</b>
<b>Specifications</b>		
<i>Linear encoders</i>	<i>Series or model</i>	
For absolute position measurement	<b>LC 400 series</b>	<b>22</b>
	<b>LC 100 series</b>	<b>26</b>
For absolute position measurement over large measuring lengths	<b>LC 200 series</b>	<b>30</b>
For incremental linear measurement with very high repeatability	<b>LF 485</b>	<b>32</b>
	<b>LF 185</b>	<b>34</b>
For incremental linear measurement	<b>LS 400 series</b>	<b>36</b>
	<b>LS 100 series</b>	<b>38</b>
For incremental linear measurement over large measuring lengths	<b>LB 382—single-section</b>	<b>40</b>
	<b>LB 382—multi-section</b>	<b>42</b>
<b>Electrical connection</b>		
	<b>Incremental signals</b>	<b>44</b>
	 1 V <sub>PP</sub>	
		<b>45</b>
	<b>Position values</b>	<b>46</b>
	EnDat	
	Fanuc, Mitsubishi, Siemens	<b>47</b>
	<b>Cables and connecting elements</b>	<b>49</b>
	<b>Diagnostic and testing equipment</b>	<b>56</b>
	<b>Interface electronics</b>	<b>58</b>

# Linear encoders for numerically controlled machine tools

Linear encoders from HEIDENHAIN for numerically controlled machine tools can be used nearly everywhere. They are ideal for machines and other equipment whose feed axes are in a servo loop, such as milling machines, machining centers, boring machines, lathes and grinding machines. The beneficial dynamic behavior of the linear encoders, their high permissible traversing speed, and their acceleration in the direction of measurement predestine them for use on highly-dynamic conventional axes as well as on direct drives.

HEIDENHAIN also supplies linear encoders for other applications, such as

- Manual machine tools
- Presses and bending machines
- Automation and production equipment

Please request further documentation, or inform yourself on the Internet at [www.heidenhain.de](http://www.heidenhain.de).

## Advantages of linear encoders

Linear encoders measure the position of linear axes without additional mechanical transfer elements. The control loop for position control with a linear encoder also includes the entire feed mechanics. Transfer errors from the mechanics can be detected by the linear encoder on the slide, and corrected by the control electronics. This makes it possible to eliminate a number of potential error sources:

- Positioning error due to thermal behavior of the recirculating ball screw
- Reversal error
- Kinematics error through ball-screw pitch error

Therefore, linear encoders are indispensable for machine tools on which high **positioning accuracy** and a high **machining rate** are essential.

## Mechanical design

The linear encoders for numerically controlled machine tools are sealed encoders: An aluminum housing protects the scale, scanning carriage and its guideway from chips, dust, and fluids. Downward-oriented elastic lips seal the housing.

The scanning carriage travels along the scale on a low-friction guide. A coupling connects the scanning carriage with the mounting block and compensates the misalignment between the scale and the machine guideways.

Depending on the encoder model, lateral and axial offsets of  $\pm 0.2$  mm to  $\pm 0.3$  mm between the scale and mounting block are permissible.



### Thermal characteristics

The combination of increasingly rapid machining processes with completely enclosed machines leads to ever-increasing temperatures within the machine's work envelope. Therefore, the thermal behavior of the linear encoders used becomes increasingly important, since it is an essential criterion for the working accuracy of the machine.

As a general rule, the thermal behavior of the linear encoder should match that of the workpiece or measured object. If the temperature changes, the linear encoder must expand or contract in a defined, reproducible manner. Linear encoders from HEIDENHAIN are designed for this.

The graduation carriers of HEIDENHAIN linear encoders have defined coefficients of thermal expansion (see *Specifications*). This makes it possible to select the linear encoder whose thermal behavior is best suited to the application.

### Dynamic behavior

The constant increases in efficiency and performance of machine tools necessitate ever-higher feed rates and accelerations, while at the same time the high level of machining accuracy must be maintained. In order to transfer rapid and yet exact feed motions, very high demands are placed on rigid machine design as well as on the linear encoders used.

Linear encoders from HEIDENHAIN are characterized by their high rigidity in the measuring direction. This is a very important prerequisite for high-quality path accuracies on a machine tool. In addition, the low mass of moving components contributes to their excellent dynamic behavior.

### Availability

The feed axes of machine tools travel quite large distances—a typical value is 10000 km in three years. Therefore, robust encoders with good long-term stability are especially important: They ensure the constant availability of the machine.

Due to the details of their design, linear encoders from HEIDENHAIN function properly even after years of operation. The contact-free principle of photoelectrically scanning the measuring standard, as well as the ball-bearing guidance of the scanning carriage in the scale housing ensure a long lifetime. This encapsulation, the special scanning principles and, if needed, the introduction of compressed air, make the linear encoders very resistant to contamination. The complete shielding design ensures a high degree of electrical noise immunity.

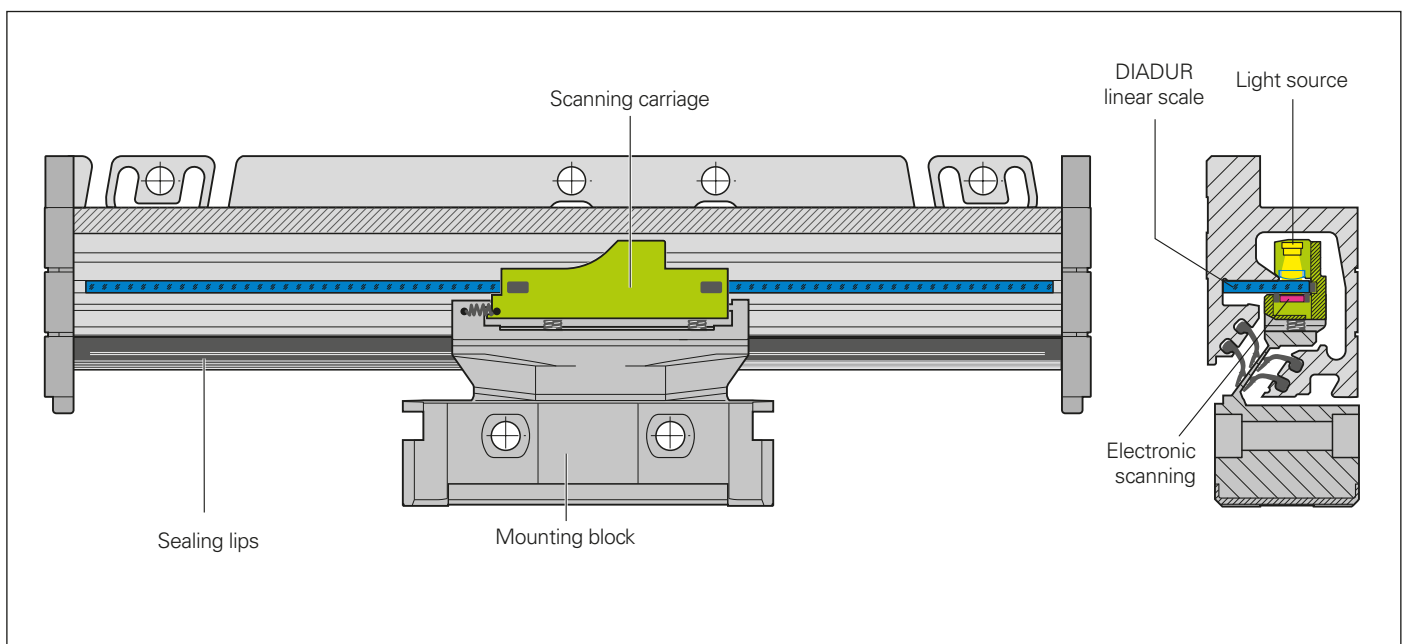

Schematic design of the **LC 115** sealed linear encoder

# Selection guide

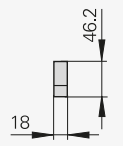
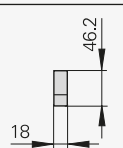
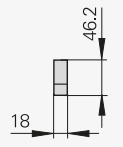

## Linear encoders with slimline scale housing

The linear encoders with **slimline scale housing** are designed for **limited installation space**. Larger measuring lengths and higher acceleration loads are made possible by using mounting spars or clamping elements.

	Cross section	Accuracy grade	Measuring length (ML)	Scanning principle
<b>Absolute position measurement</b> <ul style="list-style-type: none"> <li>Glass scale</li> </ul>		±5 µm ±3 µm	70 mm to 1240 mm <i>With mounting spar or clamping elements:</i> 70 mm to 2040 mm	Single-field scanning
<b>Incremental linear measurement with very high repeatability</b> <ul style="list-style-type: none"> <li>Steel scale</li> <li>Small signal period</li> </ul>		±5 µm ±3 µm	50 mm to 1220 mm	Single-field scanning
<b>Incremental linear measurement</b> <ul style="list-style-type: none"> <li>Glass scale</li> </ul>		±5 µm ±3 µm	70 mm to 1240 mm <i>with mounting spar:</i> 70 mm to 2040 mm	Single-field scanning

## Linear encoders with full-size scale housing

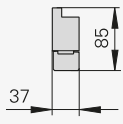
The linear encoders with **full-size scale housing** are characterized by their **sturdy construction, high resistance to vibration** and **large measuring lengths**. The scanning carriage is connected with the mounting block over an oblique blade that permits mounting both in **upright and reclining positions** with the same protection rating.

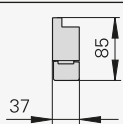
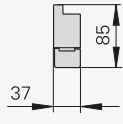
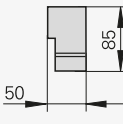
<b>Absolute position measurement</b> <ul style="list-style-type: none"> <li>Glass scale</li> </ul>		±5 µm ±3 µm	140 mm to 4240 mm	Single-field scanning
<b>Absolute position measurement</b> For large measuring lengths <ul style="list-style-type: none"> <li>Steel scale tape</li> </ul>		±5 µm	3240 mm to 28040 mm	Single-field scanning
<b>Incremental linear measurement with very high repeatability</b> <ul style="list-style-type: none"> <li>Steel scale</li> <li>Small signal period</li> </ul>		±3 µm ±2 µm	140 mm to 3040 mm	Single-field scanning
<b>Incremental linear measurement</b> <ul style="list-style-type: none"> <li>Glass scale</li> </ul>		±5 µm ±3 µm	140 mm to 3040 mm	Single-field scanning
<b>Incremental linear measurement for large measuring lengths</b> <ul style="list-style-type: none"> <li>Steel scale tape</li> </ul>		±5 µm	440 mm to 30040 mm Up to 72040 mm upon request	Single-field scanning

	Interface	Signal period	Model	Page
	EnDat 2.2	–	LC 415	22
	EnDat 2.2 with $\sim 1 V_{PP}$	20 $\mu m$	LC 485	
	DRIVE-CLiQ	–	LC 495S	
	Fanuc $\alpha i$		LC 495F	24
	Mitsubishi		LC 495M	
	$\sim 1 V_{PP}$	4 $\mu m$	LF 485	32
	$\sim 1 V_{PP}$	20 $\mu m$	LS 487	36
	$\square$ TTL	–	LS 477	
	EnDat 2.2	–	LC 115	26
	EnDat 2.2 with $\sim 1 V_{PP}$	20 $\mu m$	LC 185	
	DRIVE-CLiQ	–	LC 195S	28
	Fanuc $\alpha i$		LC 195F	
	Mitsubishi		LC 195M	
	EnDat 2.2	–	LC 211	30
	EnDat 2.2 with $\sim 1 V_{PP}$	40 $\mu m$	LC 281	
	Fanuc $\alpha i$	–	LC 291F	
	Mitsubishi		LC 291M	
	$\sim 1 V_{PP}$	4 $\mu m$	LF 185	34
	$\sim 1 V_{PP}$	20 $\mu m$	LS 187	38
	$\square$ TTL	–	LS 177	
	$\sim 1 V_{PP}$	40 $\mu m$	LB 382	40



LC 415



LF 485  
LS 487



LC 115



LF 185



LC 211

# Measuring principles

## Measuring standard

HEIDENHAIN encoders with optical scanning incorporate measuring standards of periodic structures known as graduations.

These graduations are applied to a carrier substrate of glass or steel. The scale substrate for large measuring lengths is a steel tape.

HEIDENHAIN manufactures the precision graduations in specially developed, photolithographic processes.

- AURODUR: matte-etched lines on gold-plated steel tape with typical graduation period of 40  $\mu\text{m}$
- METALLUR: contamination-tolerant graduation of metal lines on gold, with typical graduation period of 20  $\mu\text{m}$
- DIADUR: extremely robust chrome lines on glass (typical graduation period of 20  $\mu\text{m}$ ) or three-dimensional chrome structures (typical graduation period of 8  $\mu\text{m}$ ) on glass
- SUPRADUR phase grating: optically three dimensional, planar structure; particularly tolerant to contamination; typical graduation period of 8  $\mu\text{m}$  and finer
- OPTODUR phase grating: optically three dimensional, planar structure with particularly high reflectance, typical graduation period of 2  $\mu\text{m}$  and finer

Along with these very fine grating periods, these processes permit a high definition and homogeneity of the line edges. Together with the photoelectric scanning method, this high edge definition is a precondition for the high quality of the output signals.

The master graduations are manufactured by HEIDENHAIN on custom-built high-precision dividing engines.

## Absolute measuring method

With the **absolute measuring method**, the position value is available from the encoder immediately upon switch-on and can be called at any time by the subsequent electronics. There is no need to move the axes to find the reference position. The absolute position information is read **from the scale graduation**, which is formed from a serial absolute code structure. A separate incremental track is interpolated for the position value and at the same time is used to generate an optional incremental signal.

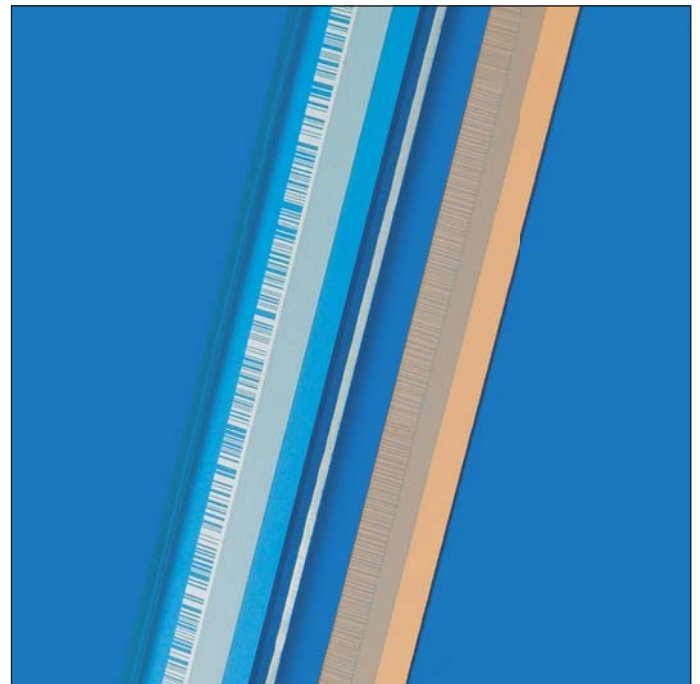

Graduations of absolute linear encoders

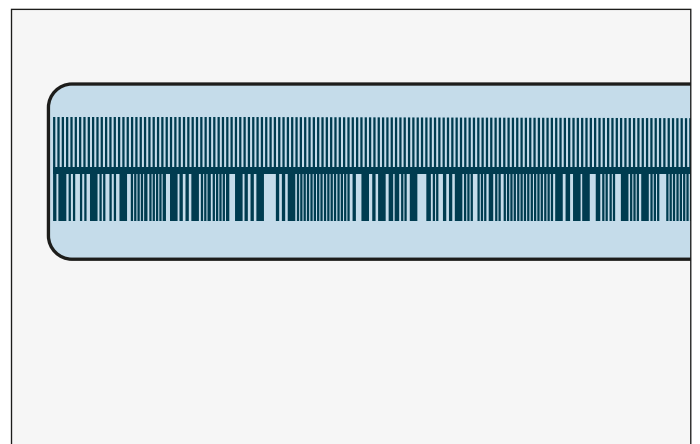

Schematic representation of an absolute code structure with an additional incremental track (LC 485 as example)



# Incremental measuring method

With the **incremental measuring method**, the graduation consists of a periodic grating structure. The position information is obtained **by counting** the individual increments (measuring steps) from some point of origin. Since an absolute reference is required to ascertain positions, the scales or scale tapes are provided with an additional track that bears a **reference mark**. The absolute position on the scale, established by the reference mark, is gated with exactly one signal period.

The reference mark must therefore be scanned to establish an absolute reference or to find the last selected datum.

In the most unfavorable case this may necessitate machine movements over large lengths of the measuring range. To speed and simplify such "reference runs," many HEIDENHAIN encoders feature **distance-coded reference marks**—multiple reference marks that are individually spaced according to a mathematical algorithm. The subsequent electronics find the absolute reference after traversing two successive reference marks—only a few millimeters traverse (see table).

Encoders with distance-coded reference marks are identified with a "C" ending the model designation (e.g. LS 487 C).

With distance-coded reference marks, the **absolute reference** is calculated by counting the signal periods between two reference marks and using the following formula:

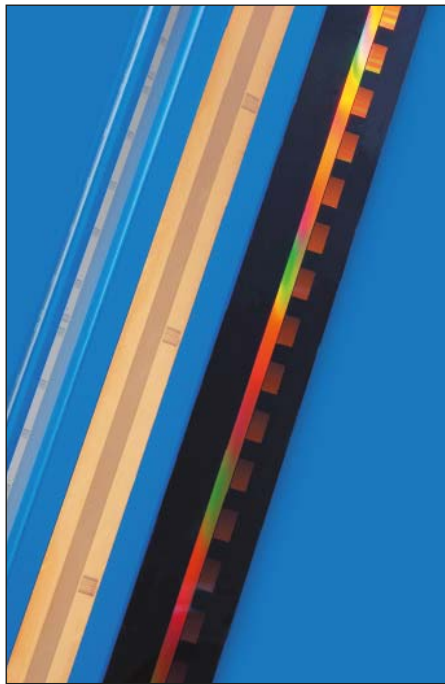

Graduations of incremental linear encoders

$$P_1 = (\text{abs } R - \text{sgn } R - 1) \times \frac{N}{2} + (\text{sgn } R - \text{sgn } D) \times \frac{\text{abs } M_{RR}}{2}$$

and

$$R = 2 \times M_{RR} - N$$

Where:

$P_1$  = Position of the first traversed reference mark in signal periods

abs = Absolute value

sgn = Algebraic sign function (" +1 " or " -1 ")

$M_{RR}$  = Number of signal periods between the traversed reference marks

N = Nominal increment between two fixed reference marks in signal periods (see table below)

D = Direction of traverse (+1 or -1). Traverse of scanning unit to the right (when properly installed) equals +1.

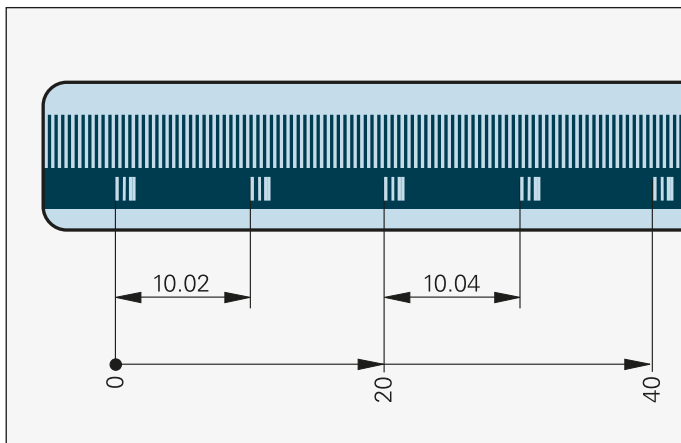

Schematic representation of an incremental graduation with distance-coded reference marks (LS as example)

	Signal period	Nominal increment N in signal periods	Maximum traverse
LF	4 μm	5000	20 mm
LS	20 μm	1000	20 mm
LB	40 μm	2000	80 mm

# Photoelectric scanning

Most HEIDENHAIN encoders operate using the principle of photoelectric scanning. Photoelectric scanning of a measuring standard is contact-free, and as such, free of wear. This method detects even very fine lines, no more than a few micrometers wide, and generates output signals with very small signal periods.

The finer the grating period of a measuring standard is, the greater the effect of diffraction on photoelectric scanning. HEIDENHAIN uses two scanning principles with linear encoders:

- The **imaging scanning principle** for grating periods of 20  $\mu\text{m}$  and 40  $\mu\text{m}$ .
- The **interferential scanning principle** for very fine graduations with grating periods of, for example, 8  $\mu\text{m}$ .

## Imaging principle

To put it simply, the imaging scanning principle functions by means of projected-light signal generation: Two scale gratings with equal or similar grating periods are moved relative to each other—the scale and the scanning reticle. The carrier material of the scanning reticle is transparent, whereas the graduation on the measuring standard may be applied to a transparent or reflective surface.

When parallel light passes through a grating, light and dark surfaces are projected at a certain distance. An index grating is located here. When the two gratings move relative to each other, the incident light is modulated. If the gaps in the gratings are aligned, light passes through. If the lines of one grating coincide with the gaps of the other, no light passes through. An array of photovoltaic cells converts these variations in light intensity into electrical signals. The specially structured grating of the scanning reticle filters the light to generate nearly sinusoidal output signals.

The smaller the period of the grating structure is, the closer and more tightly tolerated the gap must be between the scanning reticle and scale.

The LC, LS and LB linear encoders operate according to the imaging scanning principle.

Imaging principle

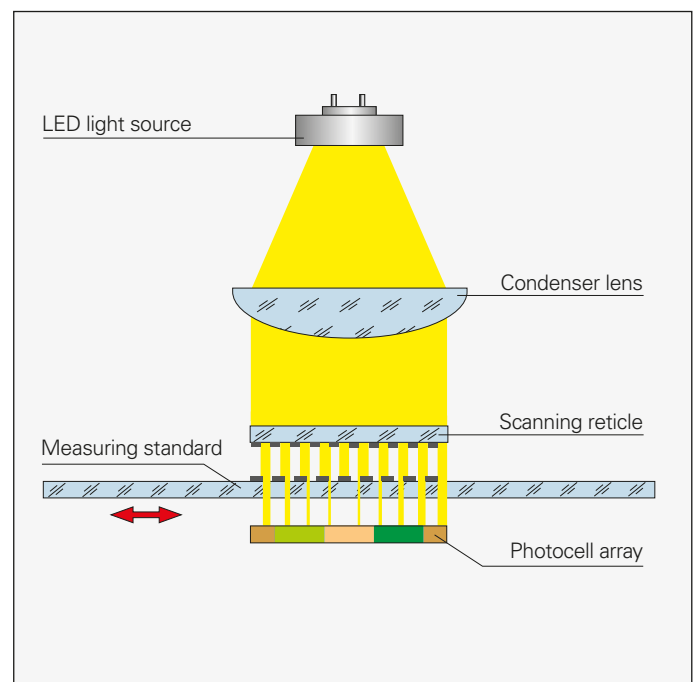

**Interferential scanning principle**

The interferential scanning principle exploits the diffraction and interference of light on a fine graduation to produce signals used to measure displacement.

A step grating is used as the measuring standard: Reflective lines 0.2 μm high are applied to a flat, reflective surface. In front of that is the scanning reticle—a transparent phase grating with the same grating period as the scale.

When a light wave passes through the scanning reticle, it is diffracted into three partial waves of the orders -1, 0, and +1, with approximately equal luminous intensity. The waves are diffracted by the scale such that most of the luminous intensity is found in the reflected diffraction orders +1 and -1. These partial waves meet again at the phase grating of the scanning reticle where they are diffracted again and interfere. This produces essentially three waves that leave the scanning reticle at different angles. Photovoltaic cells convert this alternating light intensity into electrical signals.

A relative motion of the scanning reticle to the scale causes the diffracted wave fronts to undergo a phase shift: When the grating moves by one period, the wave front of the first order is displaced by one wavelength in the positive direction, and the wavelength of diffraction order -1 is displaced by one wavelength in the negative direction. Since the two waves interfere with each other when exiting the grating, the waves are shifted relative to each other by two wavelengths. This results in two signal periods from the relative motion of just one grating period.

Interferential encoders function with grating periods of, for example, 8 μm, 4 μm and finer. Their scanning signals are largely free of harmonics and can be highly interpolated. These encoders are therefore especially suited for small measuring steps and high accuracy.

Sealed linear encoders that operate according to the interferential scanning principle are given the designation LF.

Interferential scanning principle (optics schematics)

- C Grating period
- ψ Phase shift of the light wave when passing through the scanning reticle
- Ω Phase shift of the light wave due to motion X of the scale

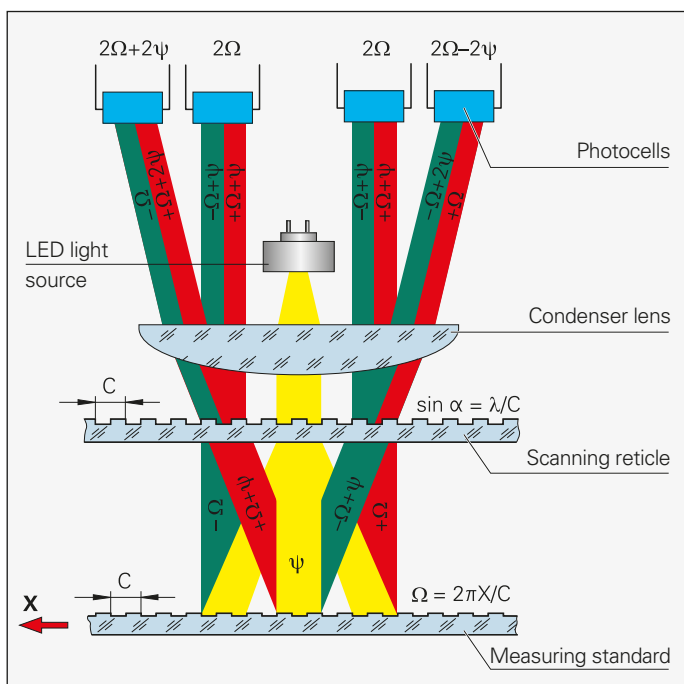

# Measuring accuracy

The accuracy of linear measurement is mainly determined by:

- the quality of the graduation
- the quality of the scanning process,
- the quality of the signal processing electronics,
- the error from the scanning unit guideway to the scale

A distinction is made between position errors over relatively large paths of traverse—for example the entire measuring length—and those within one signal period.

## Position error over the measuring range

The accuracy of sealed linear encoders is specified in grades, which are defined as follows:

*The extreme values  $\pm F$  of the measuring curves over any max. one-meter section of the measuring length lie within the accuracy grade  $\pm a$ . They are measured during the final inspection and documented in the calibration chart.*

With sealed linear encoders, these values apply to the complete encoder system including the scanning unit. It is then referred to as the system accuracy.

## Position error within one signal period

The position error within one signal period is determined by the signal period of the encoder, as well as the quality of the graduation and the scanning thereof. At any measuring position, it typically lies at  $\pm 2\%$  to  $\pm 0.5\%$  of the signal period (see table). The smaller the signal period, the smaller the position error within one signal period. It is of critical importance both for accuracy of a positioning movement as well as for velocity control during the slow, even traverse of an axis, and therefore for surface quality and the quality of the machined part.

	Signal period of the scanning signals	Max. position error $u$ within one signal period
LF	4 $\mu\text{m}$	$\pm 0.04 \mu\text{m}$
LC 100 LC 400	20 $\mu\text{m}$	$\pm 0.1 \mu\text{m}$
LC 200	40 $\mu\text{m}$	$\pm 0.4 \mu\text{m}$
LS	20 $\mu\text{m}$	$\pm 0.2 \mu\text{m}$
LB	40 $\mu\text{m}$	$\pm 0.8 \mu\text{m}$

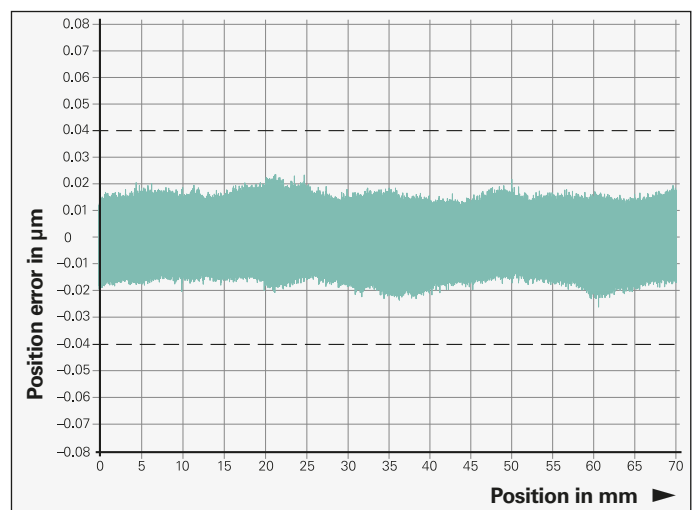
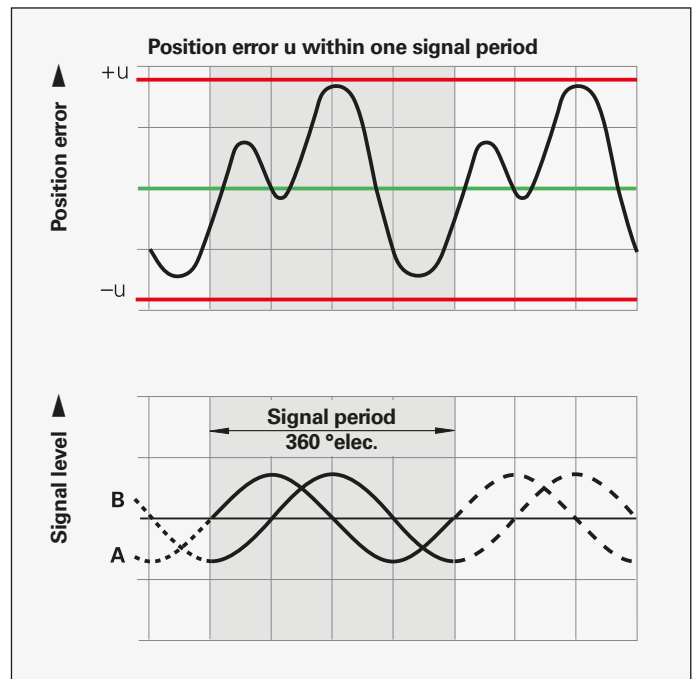
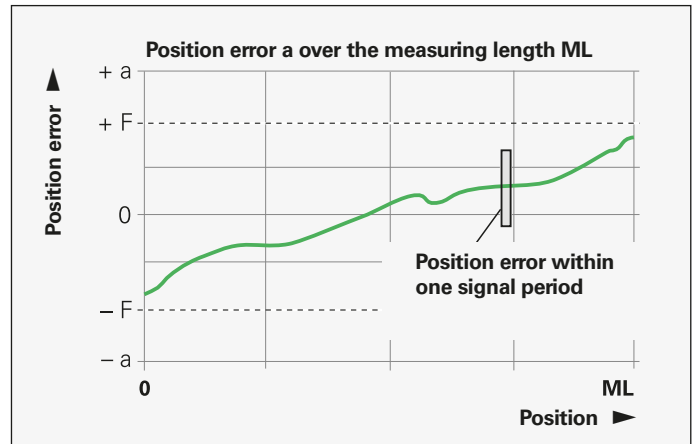

Position error within one signal period for a measuring range of 70 mm for LF encoders

All HEIDENHAIN linear encoders are inspected before shipping for positioning accuracy and proper function.

The position errors are measured by traversing in both directions, and the averaged curve is shown in the calibration chart.

The **Quality Inspection Certificate** confirms the specified system accuracy of each encoder. The **calibration standards** ensure the traceability—as required by EN ISO 9001—to recognized national or international standards.

For the LC, LF and LS series listed in this brochure, a calibration chart documents the **position error** ascertained for the measuring length. It also indicates the measuring parameters and the uncertainty of the calibration measurement.

**Temperature range**

The linear encoders are inspected at a **reference temperature** of 20 °C. The system accuracy given in the calibration chart applies at this temperature.

The **operating temperature range** indicates the ambient temperature limits between which the linear encoders will function properly.

The **storage temperature range** of -20 °C to +70 °C applies for the unit in its packaging. Starting from a measuring length of 3240 mm, the permissible storage temperature range for encoders of the LC 1x5 encoders is limited to -10 °C to +50 °C.



# HEIDENHAIN

**Qualitätsprüf-Zertifikat**  
DIN 55 350-18-4.2.2

**Quality Inspection Certificate**  
DIN 55 350-18-4.2.2

**LC 415**  
**ID 689677-19**  
**SN 37305486 A**

Positionsabweichung F [µm]  
Position error F [µm]

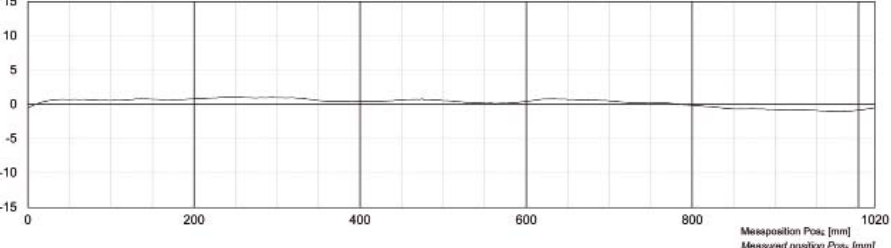

Messposition Pos<sub>M</sub> [mm]  
Measured position Pos<sub>M</sub> [mm]

Die Messkurve zeigt die Mittelwerte der Positionsabweichungen aus Vorwärts- und Rückwärtsmessung.

Positionenabweichung F des Längenmessgerätes:  $F = Pos_M - Pos_E$   
 $Pos_M$  = Messposition der Messmaschine  
 $Pos_E$  = Messposition des Längenmessgerätes

<b>Maximale Positionsabweichung der Messkurve</b>	
innerhalb 1000 mm	± 1,08 µm

<b>Unsicherheit der Messmaschine</b>	
$U_{\text{max}} = 0,2 \mu\text{m} + 0,6 \cdot 10^{-4} \cdot L$ (L=Länge Messintervall)	

<b>Messparameter</b>	
Messschritt	1000 µm
Relative Luftfeuchtigkeit	max. 50%

The error curve shows the mean values of the position errors from measurements in forward and backward direction.

Position error F of the linear encoder:  $F = Pos_M - Pos_E$   
 $Pos_M$  = position measured by the measuring machine  
 $Pos_E$  = position measured by the linear encoder

<b>Maximum position error of the error curve</b>	
within 1000 mm	± 1.08 µm

<b>Uncertainty of the measuring machine</b>	
$U_{\text{max}} = 0.2 \mu\text{m} + 0.6 \cdot 10^{-4} \cdot L$ (L=measurement interval length)	

<b>Measurement parameters</b>	
Measurement step	1000 µm
Relative humidity	max. 50%

Dieses Längenmessgerät wurde unter strengen HEIDENHAIN-Qualitätsnormen hergestellt und geprüft. Die Positionsabweichung liegt bei einer Bezugs-temperatur von 20 °C innerhalb der Genauigkeitsklasse ± 5,0 µm/m.

Kalibriernormale	Kalibrierzylinder
Jod-stabilisierter He-Ne Laser	40151 PTB 11
Wasser-Tripelpunktzelle	61 PTB 10
Galium-Schmelzpunktzelle	62 PTB 10
Barometer	6277 DKD-K-00301 10-06
Luftfeuchtemessgerät	05294 DKD-K-00305 10-06

This linear encoder has been manufactured and inspected in accordance with the stringent quality standards of HEIDENHAIN. The position error at a reference temperature of 20 °C lies within the accuracy grade ± 5.0 µm/m.

Calibration standards	Calibration references
Iodine-stabilized He-Ne Laser	40151 PTB 11
Water triple point cell	61 PTB 10
Galium melting point cell	62 PTB 10
Pressure gauge	6277 DKD-K-00301 10-06
Hygrometer	05294 DKD-K-00305 10-06

DR. JOHANNES HEIDENHAIN GmbH 83301 Traunreut www.heidenhain.de · Telefon: +49 (8669) 31-0 Fax: +49 (8669) 5081

19.03.2012  
 Prüfer/inspected by  V. dos Santos

Example

# Mechanical design types and mounting guidelines

## Linear encoders with small cross section

The LC, LF and LS slimline linear encoders should be fastened to a machined surface over their entire length, especially for highly dynamic requirements. Larger measuring lengths and higher vibration loads are made possible by using mounting spars or clamping elements (only for LC 4x5).

The slimline linear encoders feature identical mounting dimensions. This makes it possible, for example, to exchange an incremental LS or LF against an absolute LC on a specific machine design (please note the 20  $\mu\text{m}$  smaller measuring length of the LF than the LC and LS). In addition, the same mounting spars can also be used regardless of the encoder product family (LC, LF or LS).

The encoder is mounted so that the sealing lips are directed downward or away from splashing water (also see *General Mechanical Information*).

### Thermal characteristics

Because they are rigidly fastened using two M8 screws, the linear encoders largely adapt themselves to the mounting surface. When fastened over the mounting spar, the encoder is fixed at its midpoint to the mounting surface. The flexible fastening elements ensure reproducible thermal behavior.

The **LF 485** with its graduation carrier of steel has the same coefficient of thermal expansion as a mounting surface of gray cast iron or steel.

### Mounting

It is surprisingly simple to mount the sealed linear encoders from HEIDENHAIN: You need only align the scale unit at several points along the machine guideway. Stop surfaces or stop pins can also be used for this. The shipping brace already sets the proper gap between the scale unit and the scanning unit, as well as the lateral tolerance. If the shipping brace needs to be removed before mounting due to a lack of space, then the mounting gauge is used to set the gap between the scale unit and the scanning unit easily and exactly. Lateral tolerances must also be maintained.



LF 485



LC 415



LS 487

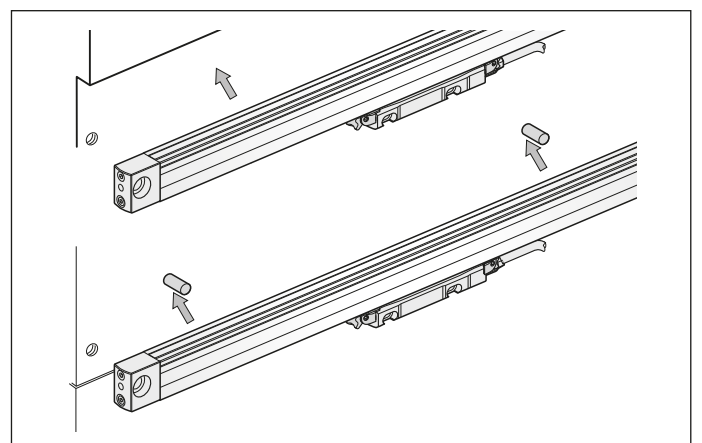
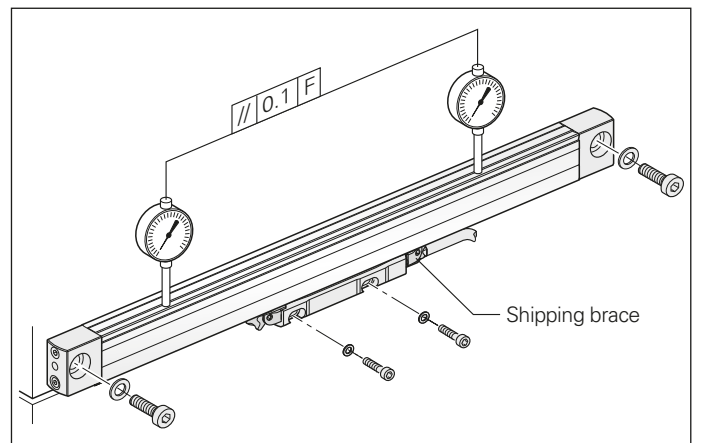
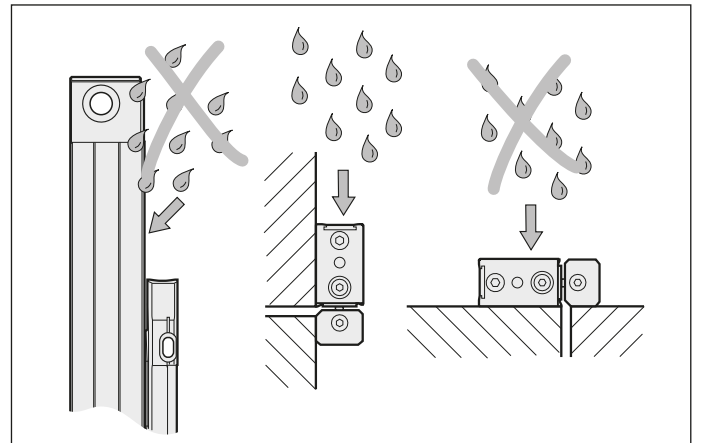

Accessories:

**Mounting and test gauges for slimline linear encoders**

The **mounting gauge** is used to set the gap between the scale unit and the scanning unit if the shipping brace needs to be removed before mounting. The **test gauges** are used to quickly and easily check the gap of the mounted linear encoder.

Along with the standard procedure of using two M8 screws to mount the scale unit on a plane surface, there are also other mounting possibilities:

**Installation with mounting spar**

Mounting the encoder with a mounting spar can be especially beneficial. It can be fastened as part of the machine assembly process. The encoder is then simply clamped on during final mounting. Easy exchange also facilitates servicing. HEIDENHAIN recommends mounting with the mounting spar when measuring lengths are over 620 mm and dynamic requirements are high. For measuring lengths over 1240 it is always required.

For the **MSL 41 mounting spar**, the components necessary for clamping are premounted. It is designed for linear encoders with normal or short end blocks. The LC 4x5, LF 4x5 and LS 4x7 can be mounted by either side to enable a cable outlet at either end. The MSL 41 mounting spar must be ordered separately.

The **mounting aid** is locked onto the mounted spar and therefore simulates an optimally mounted scanning unit. The customer's fastening for the scanning unit can be easily aligned to it. Then the mounting aid is replaced by the linear encoder.

Accessories:

**MSL 41 mounting spar**

ID 770902-xx

**Mounting aid** for scanning unit

ID 753853-01

**Mounting with clamping elements**

If the cable outlet is to the right, the LC 4x5 scanning unit, which is fastened by its end blocks, can additionally be fixed by clamping elements. This eliminates the need of a mounting spar for measuring lengths greater than 620 mm.

Accessory:

**Clamping elements**

With pin and M5x10 screw

ID 556975-01 (10 units per package)

	x	Color	ID
<b>Mounting gauge</b>	1.0 mm	Gray	737748-01
<b>Test gauge max.</b>	1.3 mm	Red	737748-02
<b>Test gauge min.</b>	0.7 mm	Blue	737748-03

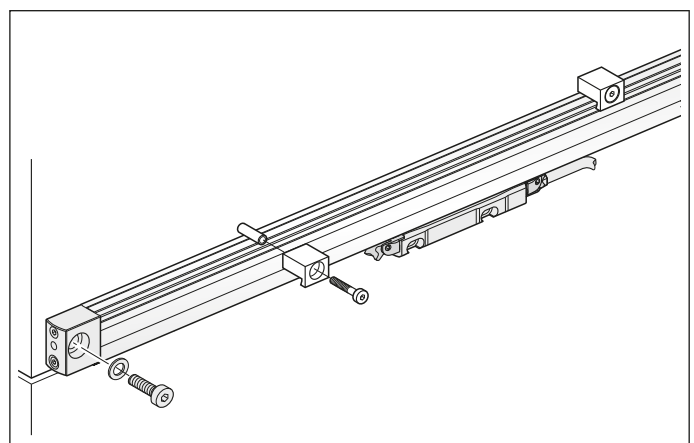
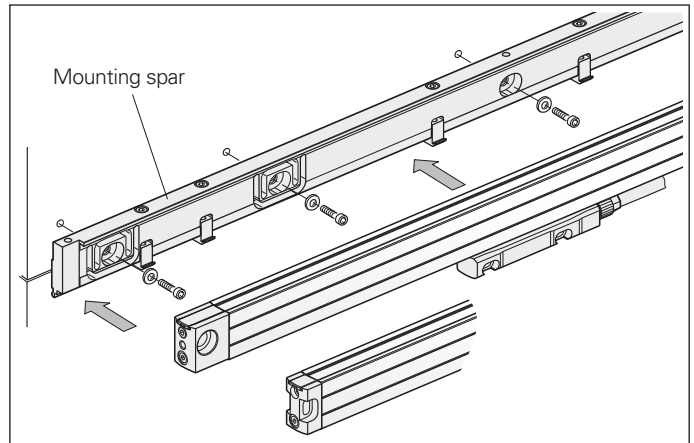
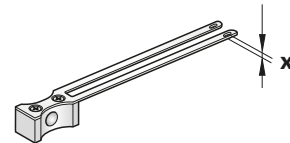

# Linear encoders with large cross section

The LB, LC, LF and LS full-size linear encoders are fastened over their entire length onto a machined surface. This gives them a **high vibration rating**. The oblique arrangement of the sealing lips permits **universal mounting** with vertical or horizontal scale housing with equally high protection rating.

The LC 1x5 features an optimized sealing system with two successive pairs of sealing lips. When cleaned compressed air is introduced into the scale housing, it effectively seals the two pairs of sealing lips against ambient air. This optimally protects the interior of the encoder from contamination.

The flow rate is set through a connecting piece with integrated throttle (see separate accessories under *Protection*, page 18).

## Thermal characteristics

The thermal behavior of the LB, LC, LF and LS 100 linear encoders with large cross section has been optimized:

On the **LF**, the steel scale is cemented to a steel carrier that is fastened directly to the machine element.

On the **LB**, the steel scale tape is clamped directly onto the machine element. The LB therefore takes part in all thermal changes of the mounting surface.

The **LC** and **LS** are fixed to the mounting surface at their midpoint. The flexible fastening elements permit reproducible thermal behavior.

## Mounting

It is surprisingly simple to mount the sealed linear encoders from HEIDENHAIN: You need only align the scale unit at several points along the machine guideway. Stop surfaces or stop pins can also be used for this. The shipping brace already sets the proper gap between the scale unit and the scanning unit. The lateral gap is to be set during mounting. If the shipping brace needs to be removed before mounting due to a lack of space, then the mounting gauge is used to set the gap between the scale unit and the scanning unit easily and exactly. Lateral tolerances must also be maintained.

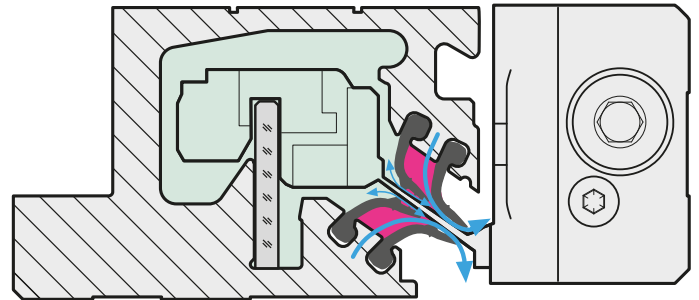

Sealing system of the LC 1x5

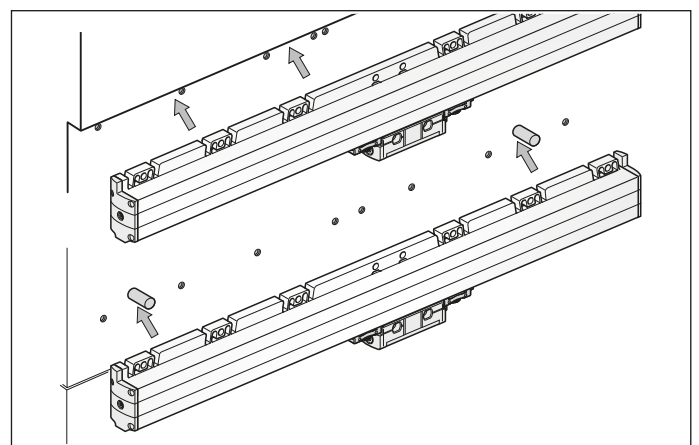
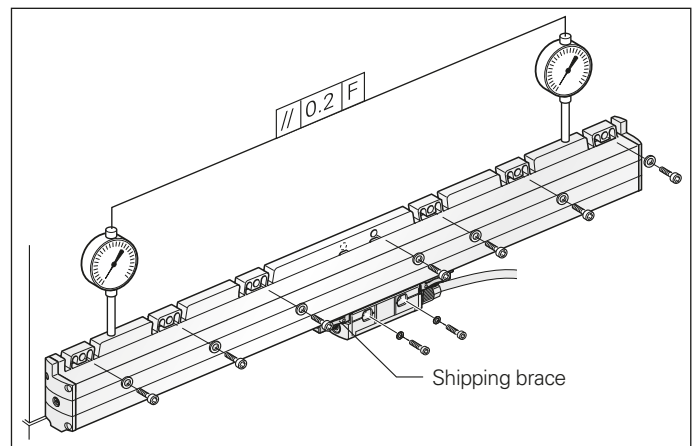
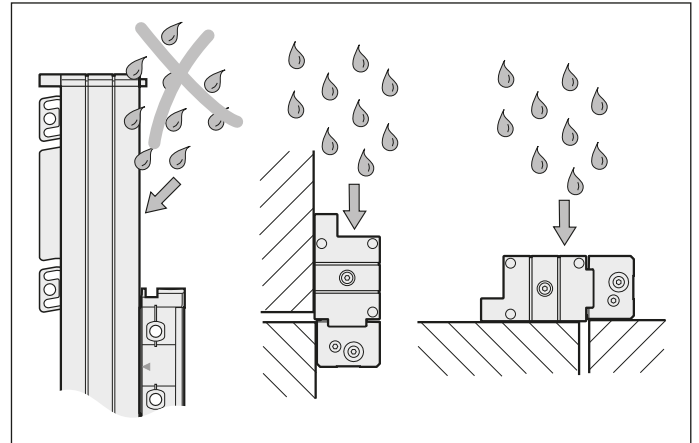



### Mounting the multi-section LC 2x1 and LB 382

The LC 2x1 and LB 382 with measuring lengths over 3240 mm are mounted on the machine in individual sections:

- Mount and align the individual housing sections
- Pull in the scale tape over the entire length and tension it
- Lubricate the sealing lips and pull them in
- Insert the scanning unit

Adjustment of the scale tape tension enables linear machine error compensation up to  $\pm 100 \mu\text{m}/\text{m}$ .

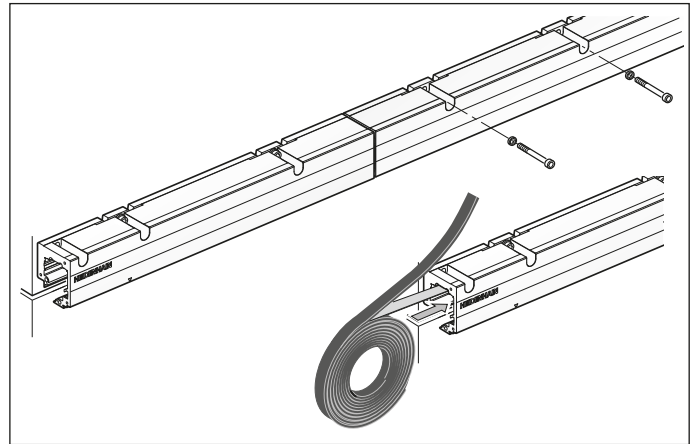

Accessory:

#### Mounting aids

- For LC 1x3, LS 1x7 ID 547793-02
- For LC 1x5 ID 1067589-02
- For LC 2x1, LB 382 ID 824039-01

The mounting aid is locked onto the scale unit, simulating an optimally adjusted scanning unit. The customer's fastening for the scanning unit can be easily aligned to it. The mounting aid is then removed and the scanning unit is attached to the mounting bracket.

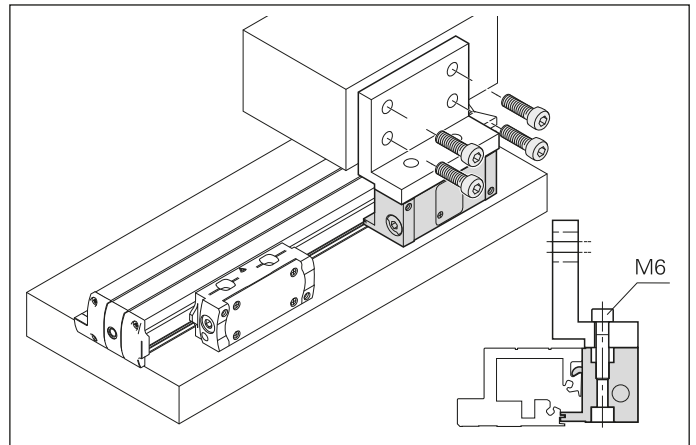

Example

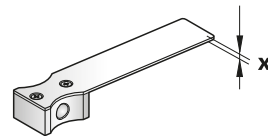

Accessory:

#### Mounting and test gauges for full-size linear encoders

The **mounting gauge** is used to set the gap between the scale unit and the scanning unit if the shipping brace needs to be removed before mounting. The **test gauges** are used to quickly and easily check the gap of the mounted linear encoder.

	LC 1xx, LS 1xx		LB 382/LC 2x1	
	x	ID	x	ID
<b>Mounting gauge (gray)</b>	1.5 mm	575832-01	1.0 mm	772141-01
<b>Test gauge max. (red)</b>	1.8 mm	575832-02	1.3 mm	772141-02
<b>Test gauge min. (blue)</b>	1.2 mm	575832-03	0.7 mm	772141-03

Accessory:

#### Lubricating device

- For LC 2x1, LB 382 sealing lips ID 1104590-04

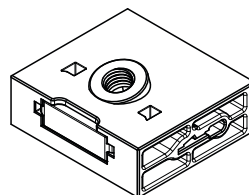

# General mechanical information

## Protection

Sealed **linear encoders** fulfill the requirements for IP53 protection according to **EN 60529** or **IEC 60529** provided that they are mounted with the sealing lips facing away from splash water. If necessary, provide a separate protective cover. If the encoder is exposed to particularly heavy concentrations of coolant and mist, **compressed air** can be used to provide **IP64** protection to more effectively prevent the ingress of contamination. To apply the pressurized air for sealing the housing, the LB, LC, LF and LS sealed linear encoders are therefore equipped with inlets at both end pieces and on the mounting block of the scanning unit.

The compressed air introduced directly onto the encoders must be cleaned by a micro filter, and must comply with the following quality classes as per **ISO 8573-1** (2010 edition):

- Solid contaminants: **Class 1**  
Particle size  
0.1 µm to 0.5 µm ≤ 20000  
0.5 µm to 1.0 µm ≤ 400  
1.0 µm to 5.0 µm ≤ 10
- Max. pressure dew point: **Class 4**  
(pressure dew point at 3 °C)
- Total oil content: **Class 1**  
(max. oil concentration: 0.01 mg/m<sup>3</sup>)

For an optimal supply of sealing air to the sealed linear encoders, the required air flow is 7 l/min to 10 l/min per encoder. Ideally the air flow is regulated by the HEIDENHAIN connecting pieces with integrated throttle (see *Accessories*). At an inlet pressure of approx.  $1 \cdot 10^5$  Pa (1 bar), the throttles ensure the prescribed volume of airflow.

Accessory:

### Connecting piece, straight

With throttle and gasket  
ID 226270-02

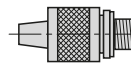

### Connecting piece, straight, short

With throttle and gasket  
ID 275239-01



Also suitable:

### Swiveling screw fitting 90°

With seal  
ID 207834-02

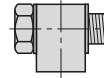

Accessory:

### DA 400 compressed air unit

ID 894602-01

### DA 400

HEIDENHAIN offers the DA 400 compressed-air filter system for purifying the compressed air. It is designed specifically for the introduction of compressed air into encoders.

The DA 400 consists of three filter stages (prefilter, fine filter and activated carbon filter) and a pressure regulator with pressure gauge. The pressure gauge and the pressure switch (which is available as an accessory) effectively monitor the sealing air.

The compressed air introduced into the DA 400 must fulfill the requirements of the following purity classes as per **ISO 8573-1** (2010 edition):

- Solid contaminants: **Class 5**  
Particle size  
0.1 µm to 0.5 µm Not specified  
0.5 µm to 1.0 µm Not specified  
1.0 µm to 5.0 µm ≤ 100000
- Max. pressure dew point: **Class 6**  
(pressure dew point at 10 °C)
- Total oil content: **Class 4**  
(max. oil concentration: 5 mg/m<sup>3</sup>)

For more information, ask for our *DA 400* Product Information Sheet.



DA 400

## Mounting

To simplify cable routing, the mounting block of the scanning unit is usually screwed onto a stationary machine part, and the scale housing on the moving part. The **mounting location** for the linear encoders should be carefully considered in order to ensure both optimum accuracy and the longest possible service life.

- The encoder should be mounted as closely as possible to the working plane to keep the Abbe error low.
- To function properly, linear encoders must not be continuously subjected to strong vibration; the more solid parts of the machine tool provide the best mounting surface in this respect. Encoders should not be mounted on hollow parts or with adapters. A mounting spar is recommended for sealed linear encoders with small cross section
- The linear encoders should be mounted away from sources of heat to avoid temperature influences

## Acceleration

Linear encoders are subjected to various types of acceleration during operation and mounting.

- The indicated maximum values for **vibration** apply for frequencies of 55 Hz to 2000 Hz (**EN 60068-2-6**), except when mechanical resonance arises. **Comprehensive tests of the entire system are therefore required**
- The maximum permissible acceleration values (semi-sinusoidal shock) for **shock and impact** are valid for 11 ms (**EN 60068-2-27**). Under no circumstances should a hammer or similar implement be used to adjust or position the encoder

## Required moving force

The required moving force stated is the maximum force required to move the scale unit relative to the scanning unit.

## RoHS

HEIDENHAIN has tested the products for safety of the materials as per European Directives 2002/95/EC (RoHS) and 2002/96/EC (WEEE). For a Manufacturer's Declaration on RoHS, please refer to your sales agency.

## Expendable parts

HEIDENHAIN encoders contain components that are subject to wear, depending on the application and handling. These include in particular the following parts:

- LED light source
  - Cables with frequent flexing
- Additionally for encoders with integral bearing:
- Bearing
  - Shaft sealing rings for rotary and angular encoders
  - Sealing lips for sealed linear encoders

## System tests

Encoders from HEIDENHAIN are usually integrated as components in larger systems. Such applications require **comprehensive tests of the entire system** regardless of the specifications of the encoder.

The specifications shown in this brochure apply to the specific encoder, and not to the entire system. Any operation of the encoder outside of the specified range or for any applications other than the intended applications is at the user's own risk.

## Mounting

Work steps to be performed and dimensions to be maintained during mounting are specified solely in the mounting instructions supplied with the unit. All data in this catalog regarding mounting are therefore provisional and not binding; they do not become terms of a contract.

DIADUR, AURODUR and METALLUR are registered trademarks of DR. JOHANNES HEIDENHAIN GmbH, Traunreut, Germany. DRIVE-CLiQ is a registered trademark of SIEMENS AG.

# Functional safety

## Safe axes

Driven axes on machine tools usually represent a great hazard for humans. Particularly if the human interacts with the machine (e.g. during workpiece setup), it must be ensured that the machine does not make any uncontrolled movements. Here the position information of axes is needed to conduct a safety function. As an evaluating safety module, the control has the task of detecting faulty position information and reacting to it accordingly.

Various safety strategies can be pursued depending on the topology of the axis and the evaluation capabilities of the control. In a single-encoder system, for example, only one encoder per axis is evaluated for the safety function. However, on axes with two encoders, e.g. linear axis with a rotary and a linear encoder, the two redundant position values can be compared with each other in the control.

Safe fault detection can be ensured only if the two components—control and encoder—are properly adapted to one another. Here it is to be noted that the safety designs of control manufacturers differ from one another. This also means that the requirements on the connected encoders sometimes differ.

## Encoders that have successfully passed type examination

Sealed linear encoders from HEIDENHAIN are used successfully on a variety of controls in widely differing safety designs. This applies particularly to the type-approved encoders LC 1x5/LC 4x5 with EnDat or DRIVE-CLiQ interfaces. The encoders can be operated as single-encoder systems in conjunction with a suitable control in applications with the control category SIL-2 (according to EN 61 508) or performance level “d” (of EN ISO 13849). Unlike incremental encoders, the absolute LC 1x5/LC 4x5 linear encoders always provide a safe absolute position value—including immediately after switch-on or a power failure. Reliable transmission of the position is based on two independently generated absolute position values and on error bits, which are provided to the safe control. The purely serial data transmission also offers other advantages, such as greater reliability, improved accuracy, diagnostic capabilities, and reduced costs through simpler connection technology.

## Standard encoders

In addition to the encoders explicitly qualified for safety applications, standard linear encoders, e.g. with Fanuc interface or 1 V<sub>PP</sub> signals, can also be used in safe axes. In these cases, the properties of the encoders are to be aligned with the requirements of the respective control. HEIDENHAIN can provide additional data on the individual encoders (failure rate, fault model as per EN 61 800-5-2, Table D16).

The safety-related characteristic values are listed in the specifications of the encoders. The Technical Information document *Safety-Related Position Encoders* provides explanations of the characteristic values.

Upon request, HEIDENHAIN can likewise provide additional data about the individual products (failure rate, fault model as per EN 61 800-5-2, D16) for the use of standard encoders in safety-related applications.

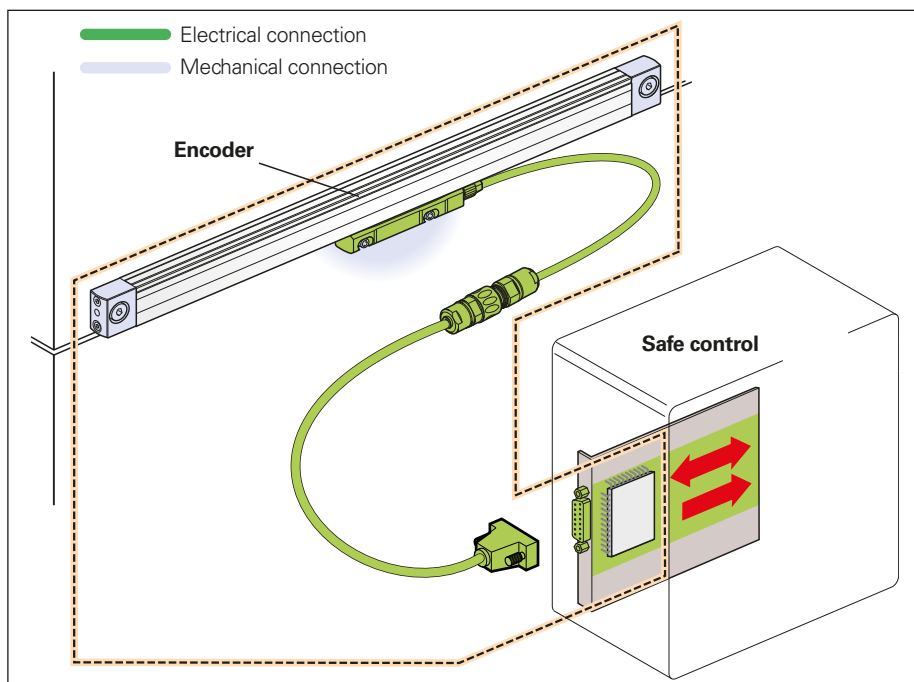

Encoder with mechanical connection and electrical interface

### Fault exclusion for the loosening of the mechanical connection

Regardless of the interface, many safety designs require a safe mechanical connection. Table D16 of the standard for electrical drives, EN 61 800-5-2, defines the loss or loosening of the mechanical connection between the encoder and drive as a fault that requires consideration. Since it cannot be guaranteed that the control will detect such errors, in many cases the possibility

of a fault must be eliminated. The requirements on a fault exclusion can result in additional constraints in the permissible limit values in the specifications. In addition, fault exclusions for the loss or loosening of the mechanical coupling usually require additional measures when mounting the encoders or in the event of servicing, e.g. anti-rotation lock for screws. These factors must be considered for the selection of a suitable encoder or a mounting mode.

### Fault exclusion for LC 1x5 and LC 4x5 series

There are various mounting options for the LC 1x5/LC 4x5 encoders that offer a fault exclusion against the loosening of the mechanical connection. The fault exclusion applies for all LC 4x5 and LC 1x5 encoders, regardless of the interface.

	Safe position for the mechanical coupling <sup>1)</sup>	Mounting	Fastening <sup>2)</sup>	Limitation of Specifications
<b>LC 1x5</b>				
Housing	±0 µm		M6 ISO 4762 8.8/A70	No
Scanning unit	±0 µm	Mounting options I and II	M6 ISO 4762 8.8/A70	No
<b>LC 4x5</b>				
Housing	±0 µm	Mounting option I End blocks 12A for M8	M8 ISO 4762 8.8/A70 M8 DIN 6912 8.8	No
	±0 µm	Mounting option III MSL 41 mounting spar ID 770902-xx	M6 ISO 4762 8.8/A70	For acceleration in measuring direction up to 60 m/s <sup>2</sup>
Scanning unit	±0 µm	All mounting options	M6 ISO 4762 8.8/A70	No

<sup>1)</sup> Fault exclusions are given only for the mounting options explicitly stated

<sup>2)</sup> A suitable anti-rotation lock is to be used for the screw connections (for mounting or service)

#### Please note the following documents:

Adhere to the information in the following documents to ensure the correct and intended operation of the encoder:

- Mounting Instructions
 

<i>LC 115/LC 195 S</i>		743390
<i>LC 415/LC 495 S</i>	(end block 14A)	737907
	(end block 12A)	737908
	(mounting spar MSL 41)	894918
- Technical Information: *Safety-Related Position Measuring Systems* 596632

For implementation in a control:

- Specification for safe control 533095

# LC 400 series

Absolute linear encoders with slimline scale housing  
 • For limited installation space

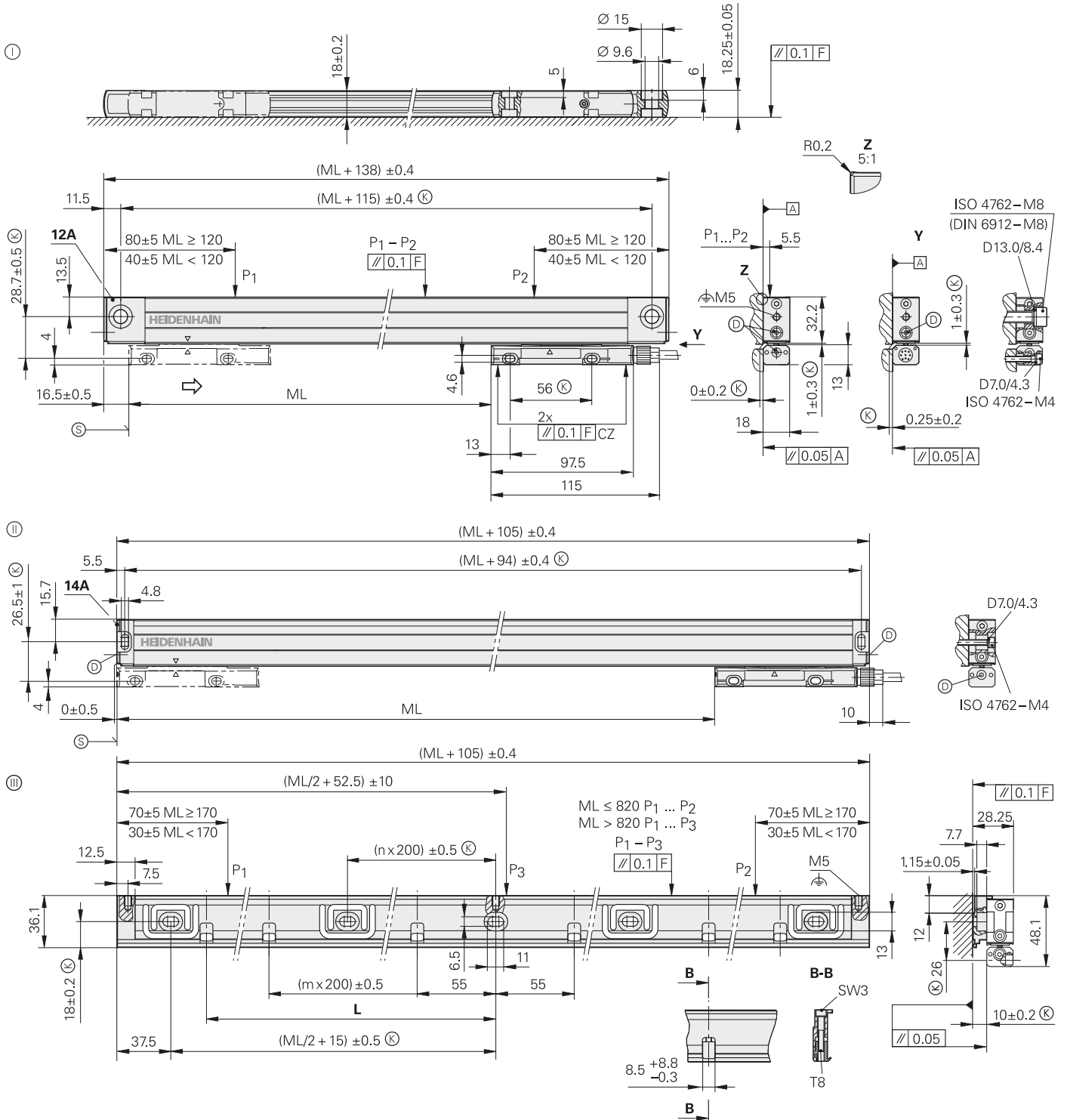

ML	70	120	170	220	270	320	370	420	470	520	570	620	670	720	770	820	920	1020	1140	1240	1340	1440	1540	1640	1740	1840	2040
L	37.5	55	75	100	115	140	175	200	225	250	275	300	325	350	375	400	450	500	555	610	655	710	760	810	855	910	1010

mm  
  
 Tolerancing ISO 8015  
 ISO 2768 - m H  
 < 6 mm: ±0.2 mm

- ⊙ = End block 12A; mounting with and without mounting spar
- ⊙ = End block 14A; for mounting with mounting spar (specifications are restricted if attached directly with M4 screws)
- ⊙ = MSL 41 mounting spar
- F = Machine guideway
- P = Gauging points for alignment
- ⊙ = Required mating dimensions
- ⊙ = Compressed air inlet
- ⊙ = Beginning of measuring length ML (= 20 mm absolute)
- ⇒ = Direction of scanning unit motion for output signals in accordance with interface description



Specifications	LC 415 	LC 415	LC 485
<b>Measuring standard</b> Coefficient of linear expansion	DIADUR glass scale with absolute track and incremental track, grating period 20 µm $\alpha_{\text{therm}} \approx 8 \times 10^{-6} \text{ K}^{-1}$ (mounting type ①/②); <i>with mounting spar</i> : $\alpha_{\text{therm}} \approx 9 \times 10^{-6} \text{ K}^{-1}$ (mounting type ③)		
<b>Accuracy grade*</b>	±3 µm, ±5 µm		
<b>Measuring length ML*</b> in mm	Mounting spar* or clamping elements* up to ML 1240 optional, necessary as of ML 1340 70 120 170 220 270 320 370 420 470 520 570 620 670 720 770 820 920 1020 1140 1240 1340 1440 1540 1640 1740 1840 2040		
<b>Functional safety</b> for applications up to	<ul style="list-style-type: none"> <li>SIL-2 according to EN 61 508</li> <li>Category 3, PL "d" according to EN ISO 13 849-1:2008</li> </ul>	–	
PFH	≤ 15 × 10 <sup>-9</sup> (up to 6000 m above sea level)	–	
Safe position <sup>1)</sup>	<i>Encoder</i> : ±550 µm (safety-related meas. step SM = 220 µm)  <i>Mechanical connection</i> : fault exclusions for loosening of the housing and scanning unit (page 21)	–	
<b>Interface</b>	EnDat 2.2		
Ordering designation	EnDat22		EnDat02
Measuring step At ±3 µm At ±5 µm	0.001 µm 0.010 µm		0.005 µm 0.010 µm
Clock frequency (calculation time $t_{\text{cal}}$ )	≤ 16 MHz (≤ 5 µs)		≤ 2 MHz (≤ 5 µs)
<b>Incremental signals</b>	–		~ 1 V <sub>PP</sub> (20 µm)
Cutoff frequency –3 dB	–		≥ 150 kHz
<b>Electrical connection</b>	Separate adapter cable (1 m/3 m/6 m/9 m) connectible to mounting block		
Cable length	≤ 100 m <sup>2)</sup>		≤ 150 m <sup>2)</sup>
Voltage supply	DC 3.6 V to 14 V		
Power consumption (max.)	3.6 V: ≤ 1.1 W; 14 V: ≤ 1.3 W		
<b>Traversing speed</b>	≤ 180 m/min (max. acceleration in measuring direction ≤ 100 m/s <sup>2</sup> )		
<b>Required moving force</b>	≤ 5 N		
<b>Vibration</b> 55 Hz to 2000 Hz effecting the	<i>Scanning unit</i> : ≤ 200 m/s <sup>2</sup> (EN 60068-2-6) <i>Housing without mounting spar</i> : ≤ 100 m/s <sup>2</sup> (EN 60068-2-6) <i>Housing with mounting spar, and cable outlet at right</i> : ≤ 150 m/s <sup>2</sup> , <i>left</i> : ≤ 100 m/s <sup>2</sup> (EN 60068-2-6)		
<b>Shock</b> 11 ms	≤ 300 m/s <sup>2</sup> (EN 60068-2-27)		
<b>Operating temperature</b>	0 °C to 50 °C		
<b>Protection</b> EN 60529 <sup>3)</sup>	IP53 when installed according to instructions in the brochure, IP64 with sealing air from DA 400		
<b>Mass</b>	<i>Encoder</i> : 0.2 kg + 0.55 kg/m measuring length; <i>mounting spar</i> : 0.9 kg/m		

\* Please select when ordering

<sup>1)</sup> Further tolerances may occur in subsequent electronics after position value comparison (contact manufacturer of subsequent electronics)

<sup>2)</sup> With HEIDENHAIN cable; clock frequency ≤ 8 MHz

<sup>3)</sup> In the application the LC must be protected from the intrusion of particles and liquids

# LC 400 series

Absolute linear encoders with slimline scale housing

- For limited installation space
- Identical dimensions for LC 415/LC 485/LC 495

Specifications	LC 495 S 	LC 495 S
<b>Measuring standard</b> Coefficient of linear expansion	DIADUR glass scale with absolute track and incremental track, grating period 20 µm $\alpha_{\text{therm}} \approx 8 \times 10^{-6} \text{ K}^{-1}$ (mounting type ①/②); <i>with mounting spar</i> : $\alpha_{\text{therm}} \approx 9 \times 10^{-6} \text{ K}^{-1}$ (mounting type ③)	
<b>Accuracy grade*</b>	±3 µm, ±5 µm	
<b>Measuring length ML*</b> in mm	Mounting spar* or clamping elements* up to ML 1240 optional, necessary as of ML 1340 70 120 170 220 270 320 370 420 470 520 570 620 670 720	
<b>Functional safety</b> for applications up to	<ul style="list-style-type: none"> <li>• SIL-2 according to EN 61 508</li> <li>• Category 3, PL "d" as per EN ISO 13 849-1:2008</li> </ul>	–
PFH	$25 \times 10^{-9}$ (up to 1000 m above sea level)	–
Safe position <sup>1)</sup>	Encoder: ±550 µm (safety-related meas. step SM = 220 µm)	–
	<i>Mechanical connection</i> : fault exclusions for loosening of the housing and scanning unit (page 21)	
<b>Interface</b>	DRIVE-CLiQ	
Ordering designation	DQ01	
Measuring step At ±3 µm At ±5 µm	0.001 µm 0.010 µm	
Clock frequency (calculation time $t_{\text{cal}}$ )	–	
<b>Electrical connection</b>	Separate adapter cable (1 m/3 m/6 m/9 m) connectible to mounting block	
Cable length	≤ 30 m <sup>2)</sup>	
Voltage supply	DC 10 V to 28.8 V	
Power consumption (max.)	10 V: ≤ 1.5 W; 28.8 V: ≤ 1.7 W	
<b>Traversing speed</b>	≤ 180 m/min (max. acceleration in measuring direction ≤ 100 m/s <sup>2</sup> )	
<b>Required moving force</b>	≤ 5 N	
<b>Vibration</b> 55 Hz to 2000 Hz affecting the	<i>Scanning unit</i> : ≤ 200 m/s <sup>2</sup> (EN 60068-2-6) <i>Housing without mounting spar</i> : ≤ 100 m/s <sup>2</sup> (EN 60068-2-6) <i>Housing with mounting spar, and cable outlet at right</i> : ≤ 150 m/s <sup>2</sup> , <i>left</i> : ≤ 100 m/s <sup>2</sup> (EN 60068-2-6)	
<b>Shock</b> 11 ms	≤ 300 m/s <sup>2</sup> (EN 60068-2-27)	
<b>Operating temperature</b>	0 °C to 50 °C	
<b>Protection</b> EN 60529 <sup>3)</sup>	IP53 when installed according to instructions in the brochure, IP64 with sealing air from DA 400	
<b>Mass</b>	Encoder: 0.2 kg + 0.55 kg/m measuring length; <i>mounting spar</i> : 0.9 kg/m	

\* Please select when ordering

1) Further tolerances may occur in subsequent electronics after position value comparison (contact manufacturer of subsequent electronics)

2) Larger cable lengths upon request

3) In the application the LC must be protected from the intrusion of particles and liquids





LC 495F		LC 495M
770 820 920 1020 1140 1240 1340 1440 1540 1640 1740 1840 2040		
Fanuc Serial Interface/αi interface		Mitsubishi high speed interface
Fanuc05		Mit03-04
αi interface/α interface 0.00125 μm/0.010 μm 0.0125 μm/0.050 μm		0.001 μm 0.010 μm
≤ 50 m		≤ 30 m
DC 3.6V to 14 V		
3.6 V: ≤ 1.1 W; 14 V: ≤ 1.3 W		

# LC 100 series

Absolute linear encoders with full-size scale housing

- High vibration resistance
- Reclining mounting possible
- High reliability through double sealing lips

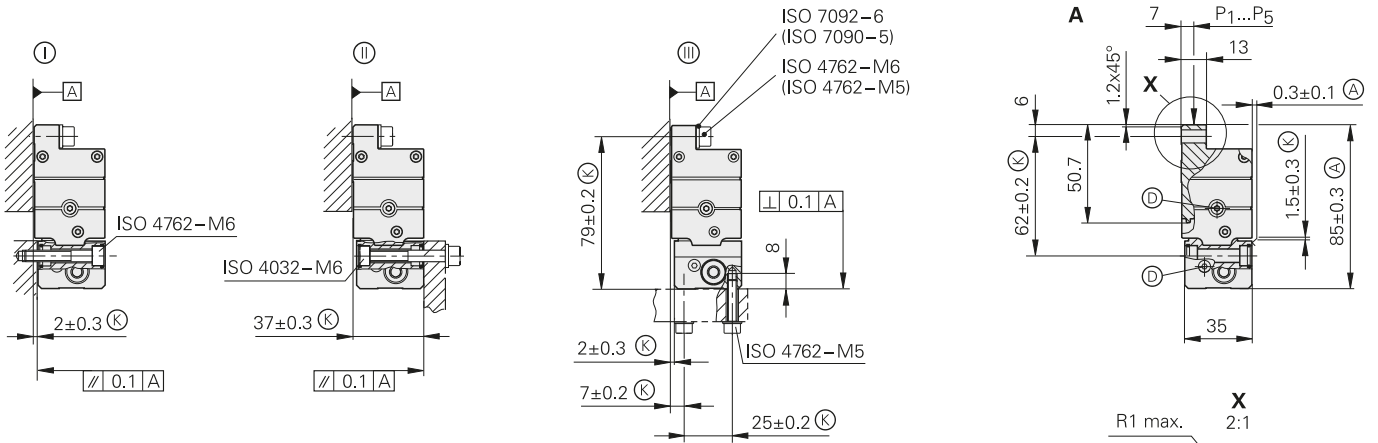
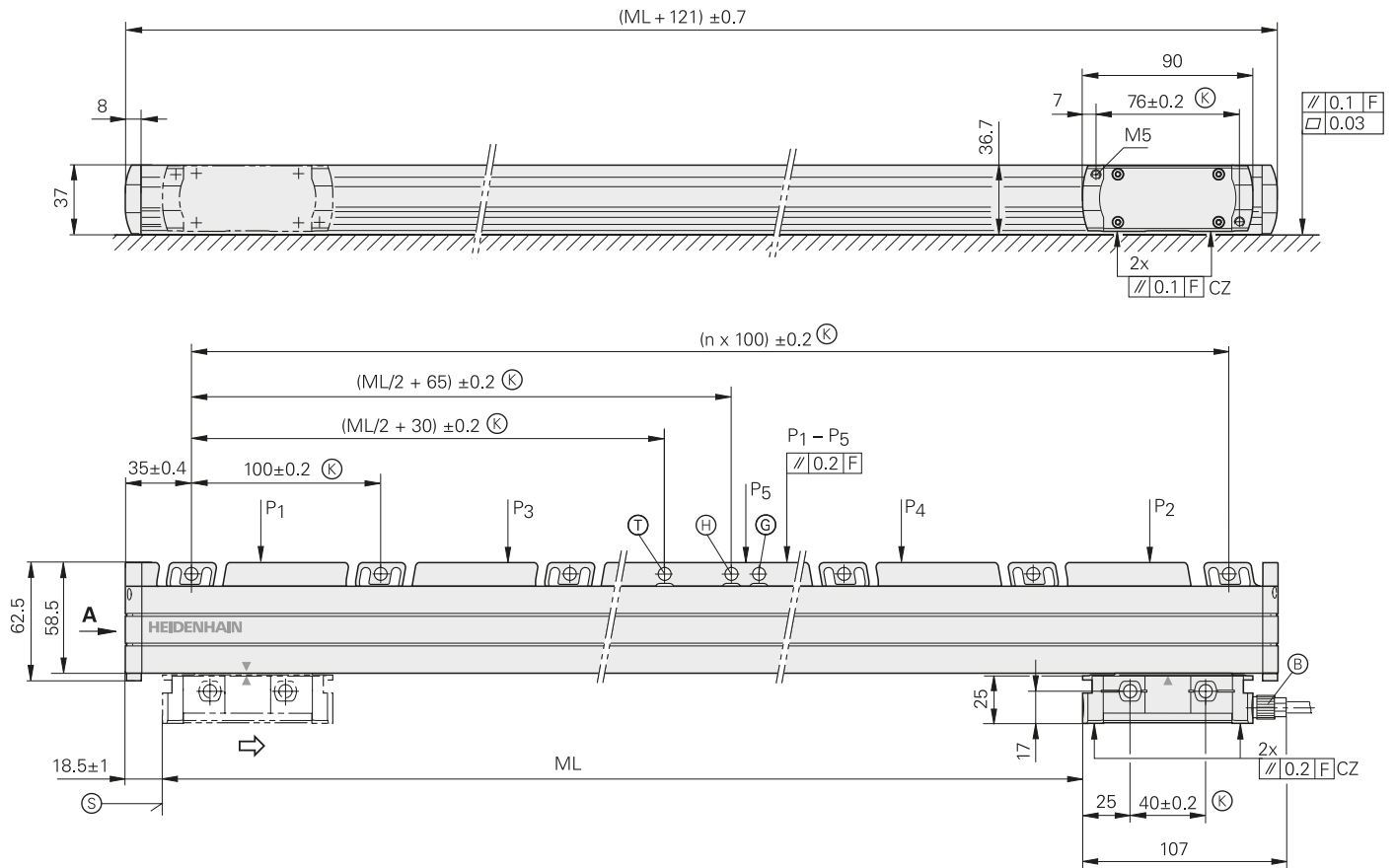

mm  
 Tolerancing ISO 8015  
 ISO 2768 - m H  
 < 6 mm:  $\pm 0.2$  mm

- Ⓚ, Ⓛ, Ⓜ = Mounting options
- F = Machine guideway
- P = Gauging points for alignment
- Ⓜ = Required mating dimensions
- Ⓜ = Alternative mating dimensions
- Ⓜ = Cable connection usable at either end
- Ⓜ = Compressed-air connection usable at either end
- Ⓜ = Mechanical fixed point (to be preferred)
- Ⓜ = Mechanical fixed point, compatible to predecessor model
- Ⓜ = Mechanical fixed point, with spacing interval of 100 mm
- Ⓜ = Beginning of measuring length ML (= 20 mm absolute)
- Ⓜ = Mating surfaces
- ⇒ = Direction of scanning unit motion for output signals in accordance with interface description



Specifications	LC 115 	LC 115	LC 185																																										
<b>Measuring standard</b> Coefficient of linear expansion	DIADUR glass scale with absolute track and incremental track, grating period 20 µm $\alpha_{\text{therm}} \approx 8 \times 10^{-6} \text{ K}^{-1}$																																												
<b>Accuracy grade*</b>	±3 µm up to 3040 mm measuring length; ±5 µm																																												
<b>Measuring length ML*</b> in mm	<table border="1"> <tr> <td>140</td><td>240</td><td>340</td><td>440</td><td>540</td><td>640</td><td>740</td><td>840</td><td>940</td><td>1040</td><td>1140</td><td>1240</td><td>1340</td><td>1440</td> </tr> <tr> <td>1540</td><td>1640</td><td>1740</td><td>1840</td><td>2040</td><td>2240</td><td>2440</td><td>2640</td><td>2840</td><td>3040</td><td>3240</td><td>3440</td><td>3640</td><td>3840</td> </tr> <tr> <td>4040</td><td>4240</td><td></td><td></td><td></td><td></td><td></td><td></td><td></td><td></td><td></td><td></td><td></td><td></td> </tr> </table>			140	240	340	440	540	640	740	840	940	1040	1140	1240	1340	1440	1540	1640	1740	1840	2040	2240	2440	2640	2840	3040	3240	3440	3640	3840	4040	4240												
140	240	340	440	540	640	740	840	940	1040	1140	1240	1340	1440																																
1540	1640	1740	1840	2040	2240	2440	2640	2840	3040	3240	3440	3640	3840																																
4040	4240																																												
<b>Functional safety</b> for applications up to	<ul style="list-style-type: none"> <li>SIL-2 according to EN 61 508</li> <li>Category 3, PL "d" according to EN ISO 13 849-1:2008</li> </ul>	–																																											
PFH	$15 \times 10^{-9}$ ; <i>ML &gt; 3040 mm:</i> $25 \times 10^{-9}$ (up to 6000 m above sea level)	–																																											
Safe position <sup>1)</sup>	<i>Encoder:</i> ±550 µm; <i>ML &gt; 3040 mm:</i> ±2050 µm (safety-related meas. step SM = 220 µm)	–																																											
	<i>Mechanical connection:</i> fault exclusions for loosening of the housing and scanning unit (page 21)																																												
<b>Interface</b>	EnDat 2.2																																												
Ordering designation	EnDat22		EnDat02																																										
Measuring step <i>At ±3 µm</i> <i>At ±5 µm</i>	0.001 µm 0.010 µm		0.005 µm 0.010 µm																																										
Clock freq. (calc. time $t_{\text{cal}}$ )	≤ 16 MHz (≤ 5 µs)		≤ 2 MHz (≤ 5 µs)																																										
<b>Incremental signals</b>	–		$\sim 1 \text{ V}_{\text{PP}}$ (20 µm)																																										
Cutoff frequency –3 dB	–		≥ 150 kHz																																										
<b>Electrical connection</b>	Separate adapter cable (1 m/3 m/6 m/9 m) connectable on both sides to mounting block																																												
Cable length	≤ 100 m <sup>2)</sup>		≤ 150 m <sup>2)</sup>																																										
Voltage supply	DC 3.6 V to 14 V																																												
Power consumption (max.)	3.6 V: ≤ 1.1 W; 14 V: ≤ 1.3 W																																												
<b>Traversing speed</b>	≤ 180 m/min (max. acceleration in measuring direction ≤ 100 m/s <sup>2</sup> )																																												
<b>Required moving force</b>	≤ 4 N																																												
<b>Vibration</b> 55 Hz to 2000 Hz affecting the <b>Shock</b> 11 ms	<i>Housing:</i> ≤ 200 m/s <sup>2</sup> (EN 60068-2-6) <i>Scanning unit:</i> ≤ 200 m/s <sup>2</sup> (EN 60068-2-6) ≤ 300 m/s <sup>2</sup> (EN 60068-2-27)																																												
<b>Operating temperature</b>	0 °C to 50 °C																																												
<b>Protection</b> EN 60529 <sup>3)</sup>	IP53 when installed according to instructions in the brochure, IP64 with sealing air from DA 400																																												
<b>Mass</b>	0.55 kg + 2.9 kg/m measuring length																																												

\* Please select when ordering

<sup>1)</sup> Further tolerances may occur in subsequent electronics after position value comparison (contact manufacturer of subsequent electronics)

<sup>2)</sup> With HEIDENHAIN cable; clock frequency ≤ 8 MHz

<sup>3)</sup> In the application the LC must be protected from the intrusion of particles and liquids

# LC 100 series

Absolute linear encoders with full-size scale housing

- High vibration resistance
- Reclining mounting possible
- High reliability through double sealing lips

Specifications	LC 195S 	LC 195S
<b>Measuring standard</b> Coefficient of linear expansion	DIADUR glass scale with absolute track and incremental track, grating period 20 µm $\alpha_{\text{therm}} \approx 8 \times 10^{-6} \text{ K}^{-1}$	
<b>Accuracy grade*</b>	±3 µm up to 3040 mm measuring length; ±5 µm	
<b>Measuring length ML*</b> in mm	140 240 340 440 540 640 740 840 940 1040 1140 1240 1340	
<b>Functional safety</b> for applications up to	<ul style="list-style-type: none"> <li>• SIL-2 according to EN 61 508</li> <li>• Category 3, PL "d" as per EN ISO 13 849-1:2008</li> </ul>	–
PFH	$25 \times 10^{-9}$ ; <i>ML &gt; 3040 mm</i> : $40 \times 10^{-9}$ (up to 1000 m above sea level)	–
Safe position <sup>1)</sup>	<i>Encoder</i> : ±550 µm; <i>ML &gt; 3040 mm</i> : ±2050 µm (safety-related measuring step SM = 220 µm)	–
	<i>Mechanical connection</i> : fault exclusions for loosening of the housing and scanning unit (page 21)	
<b>Interface</b>	DRIVE-CLiQ	
Ordering designation	DQ01	
Measuring step At ±3 µm At ±5 µm	0.001 µm 0.010 µm	
Clock freq. (calc. time $t_{\text{cal}}$ )	–	
<b>Electrical connection</b>	Separate adapter cable (1 m/3 m/6 m/9 m) connectable on both sides to mounting block	
Cable length	≤ 30 m <sup>2)</sup>	
Voltage supply	DC 10 V to 28.8 V	
Power consumption (max.)	10 V: ≤ 1.5 W; 28.8 V: ≤ 1.7 W	
<b>Traversing speed</b>	≤ 180 m/min (max. acceleration ≤ 100 m/s <sup>2</sup> )	
<b>Required moving force</b>	≤ 4 N	
<b>Vibration</b> 55 Hz to 2000 Hz effecting the <b>Shock</b> 11 ms	<i>Housing</i> : ≤ 200 m/s <sup>2</sup> (EN 60 068-2-6) <i>Scanning unit</i> : ≤ 200 m/s <sup>2</sup> (EN 60 068-2-6) ≤ 300 m/s <sup>2</sup> (EN 60 068-2-27)	
<b>Operating temperature</b>	0 °C to 50 °C	
<b>Protection</b> EN 60 529 <sup>3)</sup>	IP53 when installed according to instructions in the brochure, IP64 with sealing air from DA 400	
<b>Mass</b>	0.55 kg + 2.9 kg/m measuring length	

\* Please select when ordering

<sup>1)</sup> Further tolerances may occur in subsequent electronics after position value comparison (contact manufacturer of subsequent electronics)

<sup>2)</sup> Larger cable lengths upon request

<sup>3)</sup> In the application the LC must be protected from the intrusion of particles and liquids



LC 195F		LC 195M
1440 1540 1640 1740 1840 2040 2240 2440 2640 2840 3040 3240 3440 3640 3840 4040 4240		
Fanuc Serial Interface/αi interface		Mitsubishi high speed interface
Fanuc05		Mit03-04
αi interface/α interface 0.00125 μm/0.010 μm 0.0125 μm/0.050 μm		0.001 μm 0.010 μm
≤ 50 m		≤ 30 m
DC 3.6 V to 14 V		
3.6 V: ≤ 1.1 W; 14 V: ≤ 1.3 W		

# LC 200 series

Absolute linear encoders with full-size scale housing

- Measuring lengths up to 28 m
- Simplified mounting (upright or reclining)
- Also available in mirrored version (mating dimensions upon request)

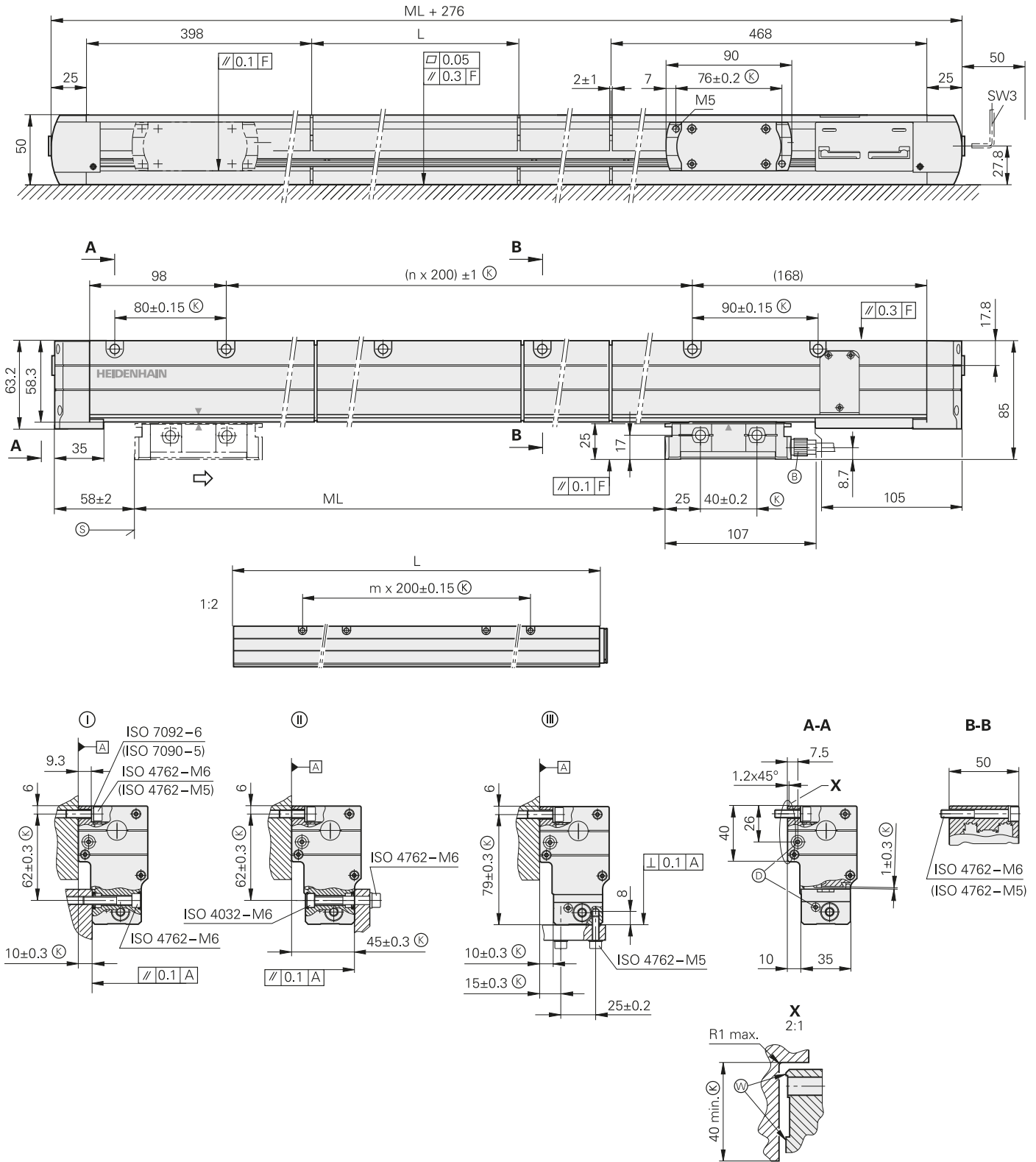

mm  
  
 Tolerancing ISO 8015  
 ISO 2768 - m H  
 < 6 mm: ±0.2 mm

- ⓪, Ⓜ, Ⓝ
- Ⓜ = Mounting options
- F = Machine guideway
- L = Housing section lengths
- Ⓚ = Required mating dimensions
- Ⓟ = Cable connection usable at either end
- Ⓠ = Compressed-air connection usable at either end
- Ⓡ = Beginning of measuring length ML (= 100 mm absolute)
- Ⓢ = Mating surfaces
- ⇨ = Direction of scanning unit motion for output signals in accordance with interface description



Specifications	LC 211	LC 281	LC 291F	LC 291M
<b>Measuring standard</b> Coefficient of linear expansion	METALLUR steel scale tape with absolute track and incremental track, grating period 40 µm Same as machine base (e.g. $\alpha_{\text{therm}} \approx 10 \times 10^{-6} \text{ K}^{-1}$ for gray cast iron)			
<b>Accuracy grade</b>	±5 µm			
<b>Measuring length ML*</b> in mm	3240 mm to 28040 mm in 200 mm steps Kit with single-section METALLUR steel scale tape and housing section lengths			
<b>Interface</b>	EnDat 2.2		Fanuc Serial Interface $\alpha$ interface	Mitsubishi high speed interface
Ordering designation	EnDat22	EnDat02	Fanuc05	Mit03-04
Measuring step	0.010 µm		$\alpha$ interface/ $\alpha$ interface 0.0125 µm/0.050 µm	0.010 µm
Diagnostics interface	Digital			
Clock frequency	≤ 16 MHz	≤ 2 MHz	–	–
Calculation time $t_{\text{cal}}$	≤ 5 µs	≤ 5 µs	–	–
<b>Incremental signals</b>	–	~ 1 V <sub>PP</sub>	–	–
Signal period	–	40 µm	–	–
Cutoff frequency –3 dB	–	≥ 250 kHz	–	–
<b>Electrical connection</b>	Separate adapter cable (1 m/3 m/6 m/9 m) connectable on both sides to mounting block			
Cable length <sup>1)</sup>	≤ 100 m (at clock frequency ≤ 8 MHz)	≤ 150 m	≤ 50 m	≤ 30 m
Voltage supply	DC 3.6 V to 14 V			
Power consumption (max.)	At 14 V: ≤ 1.3 W At 3.6 V: ≤ 1.1 W			
Current consumption (typical)	At 5 V: 225 mA (without load)			
<b>Traversing speed</b>	≤ 180 m/min (max. acceleration in measuring direction ≤ 100 m/s <sup>2</sup> )			
<b>Required moving force</b>	≤ 15 N			
<b>Vibration</b> 55 Hz to 2000 Hz effecting the <b>Shock</b> 11 ms	Housing: 200 m/s <sup>2</sup> (EN 60068-2-6) Scanning unit: 300 m/s <sup>2</sup> (EN 60068-2-6) ≤ 300 m/s <sup>2</sup> (EN 60068-2-27)			
<b>Operating temperature</b>	0 °C to 50 °C			
<b>Protection</b> EN 60529	IP53 when installed according to mounting instructions, IP64 with sealing air from DA 400			
<b>Mass</b>	1.3 kg + 3.6 kg/m measuring length			

\* Please select when ordering

<sup>1)</sup> With HEIDENHAIN cable

# LF 485

## Incremental linear encoders with slimline scale housing

- Very high repeatability
- Thermal behavior similar to steel or gray cast iron
- For limited installation space

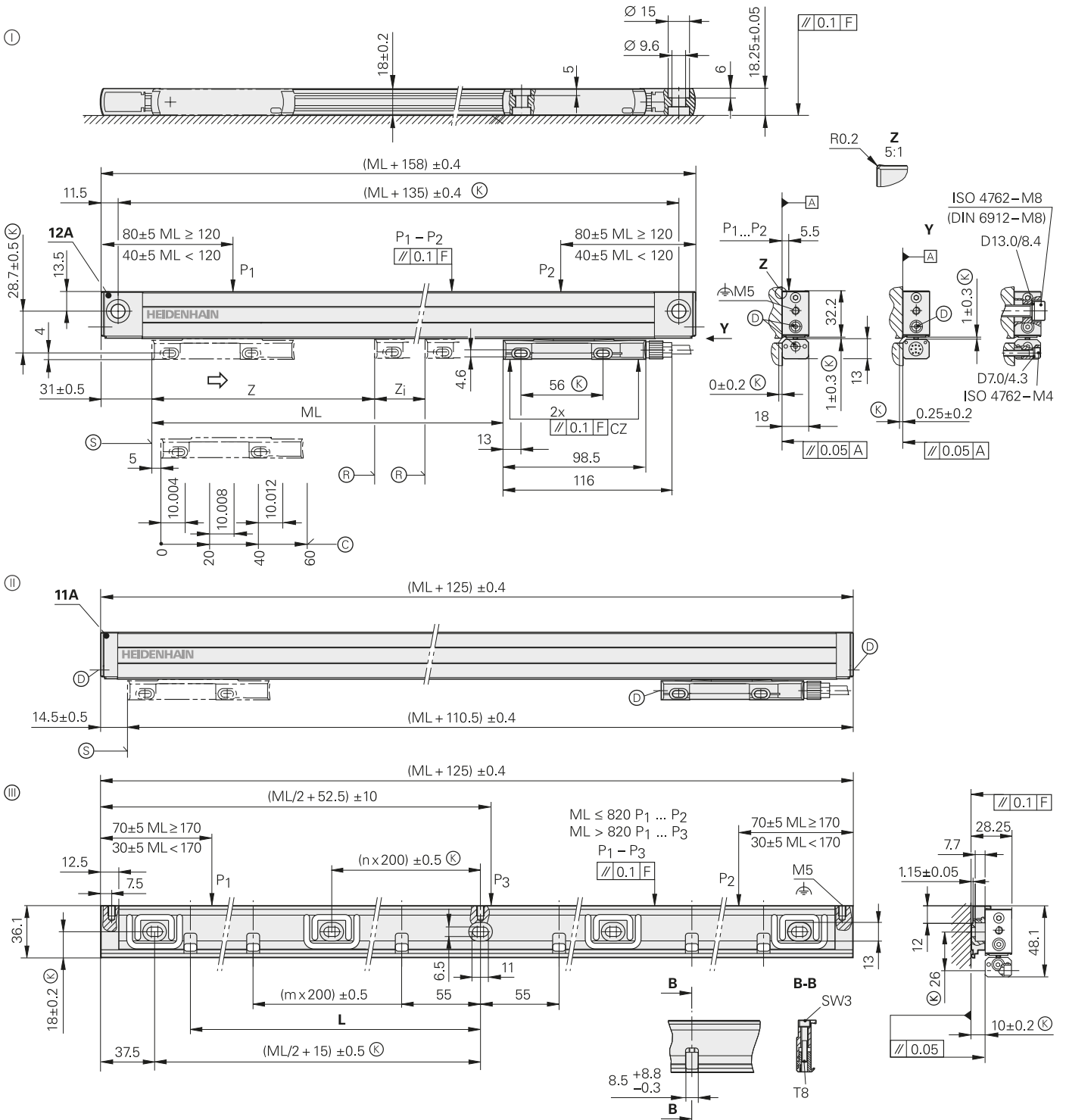

ML	50	100	150	200	250	300	350	400	450	500	550	600	650	700	750	800	850	900	950	1000	1050	1120	1220	1320	1420	1520	1620	1720	1820	2020
L	37.5	55	75	100	115	140	175	200	225	250	275	300	325	350	375	400	425	450	475	500	515	555	610	655	710	760	810	855	910	1010

mm  
  
 Tolerancing ISO 8015  
 ISO 2768 - m H  
 < 6 mm: ±0.2 mm

- ⊙ = End block 12A; mounting with and without mounting spar
- ⊙ = End block 11A; installation with mounting spar
- ⊙ = MSL 41 mounting spar
- F = Machine guideway
- P = Gauging points for alignment
- ⊙ = Required mating dimensions

- ⊙ = Reference mark position on LF 485  
 2 reference marks for measuring lengths  

50 ... 1000	1120 ... 1220
z = 25 mm	z = 35 mm
z <sub>1</sub> = ML - 50 mm	z <sub>1</sub> = ML - 70 mm
- ⊙ = Reference-mark position on LF 485 C
- ⊙ = Compressed air inlet
- ⊙ = Beginning of measuring length ML
- ⇒ = Direction of scanning unit motion for output signals in accordance with interface description



LF 485 without mounting spar



LF 485 with mounting spar

Specifications	LF 485
<b>Measuring standard</b> Coefficient of linear expansion	SUPRADUR phase grating on steel, grating period 8 $\mu\text{m}$ $\alpha_{\text{therm}} \approx 10 \times 10^{-6} \text{ K}^{-1}$
<b>Accuracy grade*</b>	$\pm 5 \mu\text{m}$ ; $\pm 3 \mu\text{m}$
<b>Measuring length ML*</b> in mm	Mounting spar* optional 50 100 150 200 250 300 350 400 450 500 550 600 650 700 750 800 900 1000 1120 1220
<b>Interface</b>	$\sim 1 \text{ V}_{\text{PP}}$
Signal period	4 $\mu\text{s}$
Reference marks* LF 485 LF 485 C	<ul style="list-style-type: none"> <li>• 1 reference mark at midpoint of measuring length</li> <li>• 2 reference marks, each 25 mm (for <math>\text{ML} \leq 1000 \text{ mm}</math>) or 35 mm (for <math>\text{ML} \geq 1120 \text{ mm}</math>) from the beginning and end of the measuring length</li> </ul> Distance-coded
Diagnostics interface	Analog
Cutoff frequency -3 dB	$\geq 250 \text{ kHz}$
<b>Electrical connection</b>	Separate adapter cable (1 m/3 m/6 m/9 m) connectible to mounting block
Cable length	$\leq 150 \text{ m}$ (with HEIDENHAIN cable)
Voltage supply without load	DC 5 V $\pm 0.25 \text{ V}$ / $< 150 \text{ mA}$
<b>Traversing speed</b>	$\leq 60 \text{ m/min}$ (max. acceleration in measuring direction $\leq 100 \text{ m/s}^2$ )
<b>Required moving force</b>	$\leq 4 \text{ N}$
<b>Vibration</b> 55 Hz to 2000 Hz affecting the <b>Shock</b> 11 ms	<i>Housing with mounting spar:</i> $\leq 150 \text{ m/s}^2$ (EN 60068-2-6) <i>Scanning unit:</i> $\leq 200 \text{ m/s}^2$ (EN 60068-2-6) $\leq 300 \text{ m/s}^2$ (EN 60068-2-27)
<b>Operating temperature</b>	0 °C to 50 °C
<b>Protection</b> EN 60529	IP53 when installed according to instructions in the brochure IP64 with sealing air via DA 400
<b>Mass</b>	0.4 kg + 0.6 kg/m measuring length

\* Please select when ordering

# LF 185

## Incremental linear encoders with full-size scale housing

- Very high repeatability
- Thermal behavior similar to steel or gray cast iron
- Reclining mounting possible

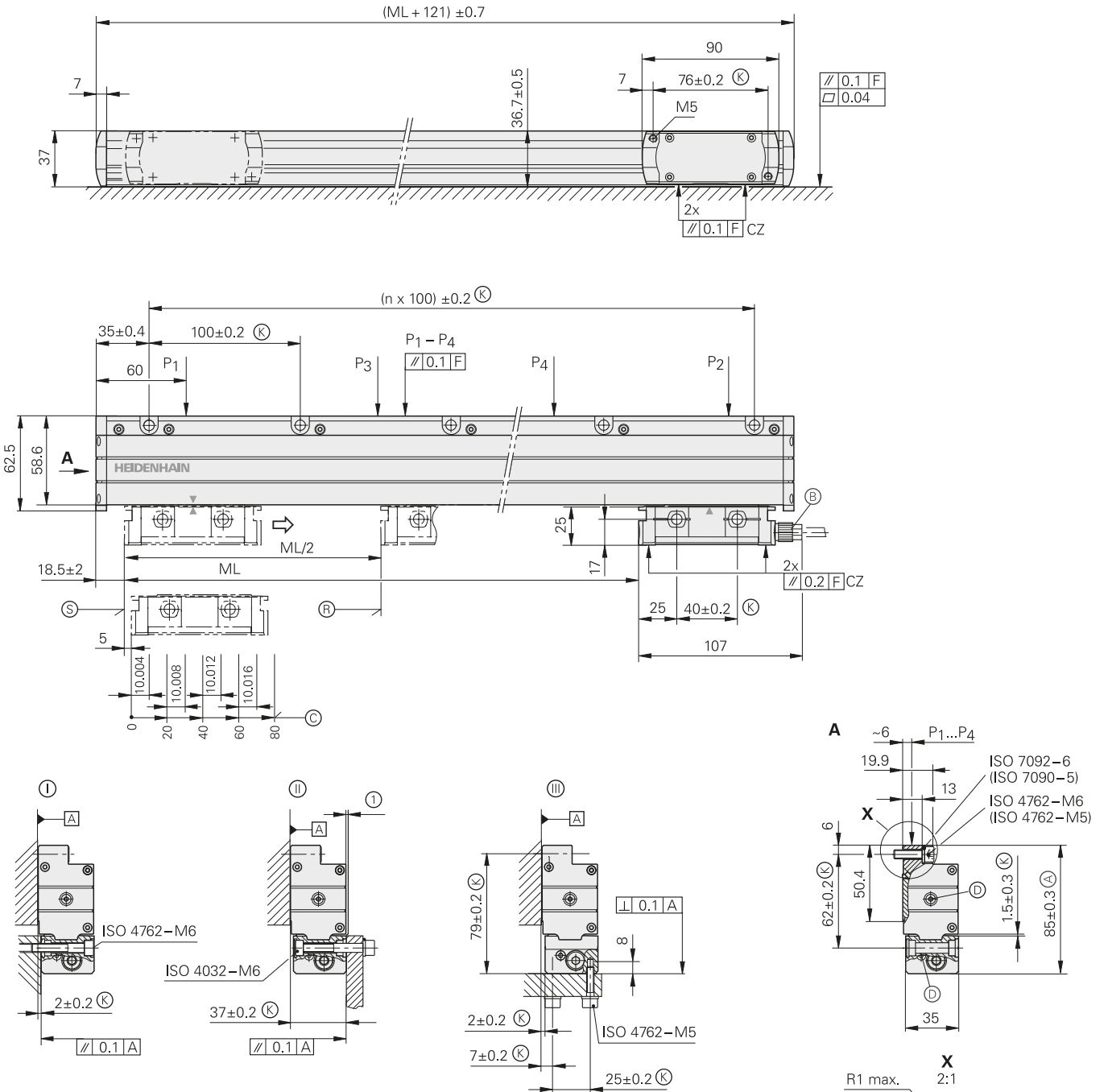

mm  
  
 Tolerancing ISO 8015  
 ISO 2768 - m H  
 < 6 mm:  $\pm 0.2$  mm

- Ⓚ, Ⓛ, Ⓜ, Ⓝ = Mounting options
- F = Machine guideway
- P = Gauging points for alignment
- ML = Measuring length
- Ⓚ = Required mating dimensions
- Ⓛ = Alternative mating dimensions
- Ⓝ = Cable connection usable at either end
- Ⓞ = Compressed air inlet usable at either end
- Ⓢ = Beginning of measuring length ML
- Ⓞ = Reference-mark position on LF 185
- Ⓞ = Reference-mark position on LF 185 C
- Ⓞ = Mating surfaces
- Ⓞ = Not an alternative mating dimension, as opposed to LS/LC 100
- ⇒ = Direction of scanning unit motion for output signals in accordance with interface description



Specifications	LF 185
<b>Measuring standard</b> Coefficient of linear expansion	SUPRADUR phase grating on steel, grating period 8 µm $\alpha_{\text{therm}} \approx 10 \times 10^{-6} \text{ K}^{-1}$
<b>Accuracy grade*</b>	±3 µm; ±2 µm
<b>Measuring length ML*</b> in mm	140 240 340 440 540 640 740 840 940 1040 1140 1240 1340 1440 1540 1640 1740 1840 2040 2240 2440 2640 2840 3040
<b>Interface</b>	~ 1 V <sub>PP</sub>
Signal period	4 µm
Reference marks* <i>LF 185</i> <i>LF 185C</i>	1 reference mark at midpoint; other reference mark positions upon request Distance-coded
Diagnostics interface	Analog
Cutoff frequency -3 dB	≥ 250 kHz
<b>Electrical connection</b>	Separate adapter cable (1 m/3 m/6 m/9 m) connectible to mounting block
Cable length	≤ 150 m (with HEIDENHAIN cable)
Voltage supply without load	DC 5 V ±0.25 V / < 150 mA
<b>Traversing speed</b>	≤ 60 m/min (max. acceleration in measuring direction ≤ 100 m/s <sup>2</sup> )
<b>Required moving force</b>	≤ 4 N
<b>Vibration</b> 55 Hz to 2000 Hz affecting the <b>Shock</b> 11 ms	<i>Housing:</i> ≤ 150 m/s <sup>2</sup> (EN 60068-2-6) <i>Scanning unit:</i> ≤ 200 m/s <sup>2</sup> (EN 60068-2-6) ≤ 300 m/s <sup>2</sup> (EN 60068-2-27)
<b>Operating temperature</b>	0 °C to 50 °C
<b>Protection</b> EN 60529	IP53 when installed according to instructions in the brochure IP64 with sealing air via DA 400
<b>Mass</b>	0.8 kg + 4.6 kg/m measuring length

\* Please select when ordering

# LS 400 series

Incremental linear encoders with slimline scale housing  
 • For limited installation space

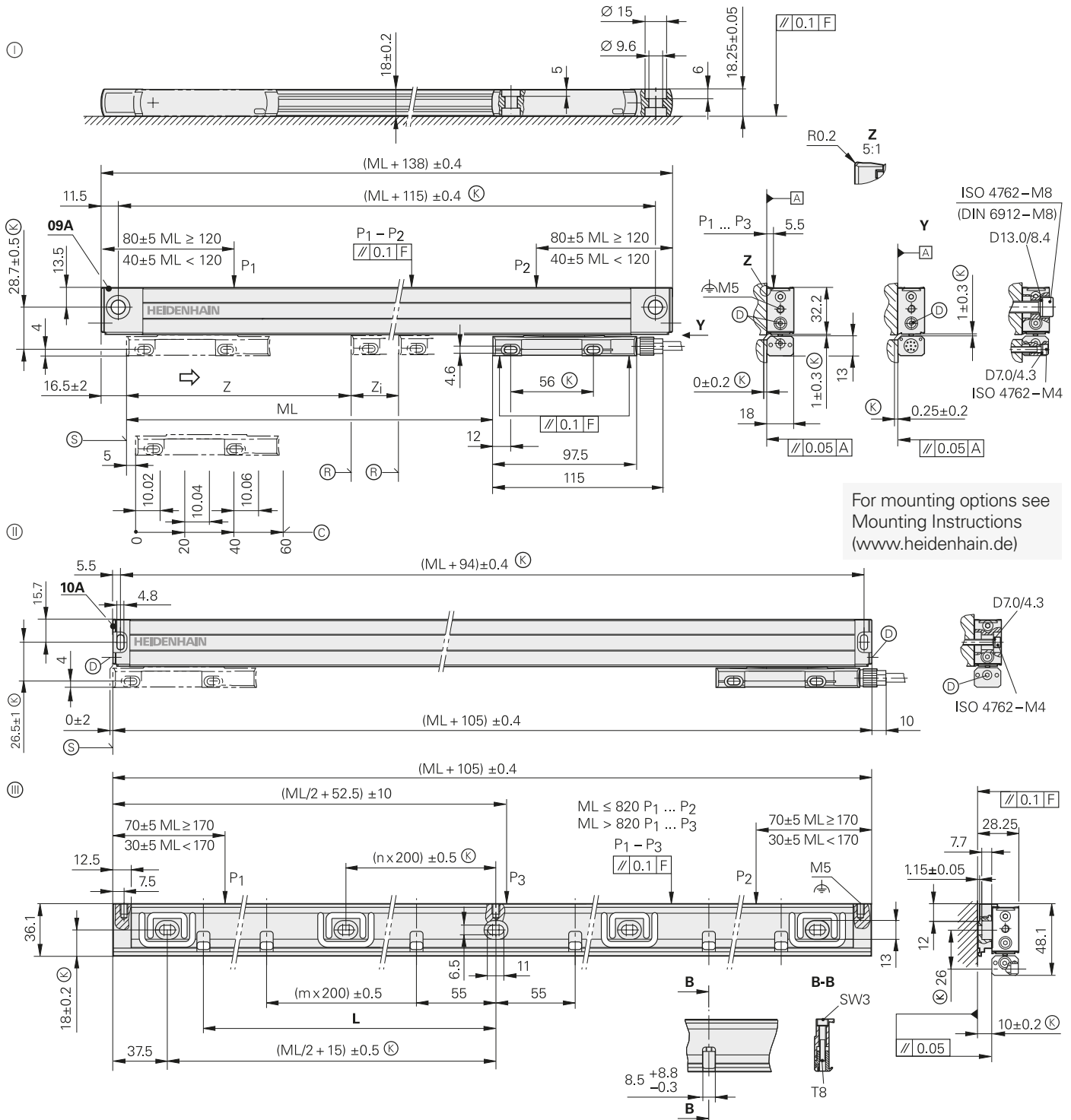

ML	70	120	170	220	270	320	370	420	470	520	570	620	670	720	770	820	870	920	970	1020	1070	1140	1240	1340	1440	1540	1640	1740	1840	2040
L	37.5	55	75	100	115	140	175	200	225	250	275	300	325	350	375	400	425	450	475	500	515	555	610	655	710	760	810	855	910	1010

mm  
  
 Tolerancing ISO 8015  
 ISO 2768 - m H  
 < 6 mm: ±0.2 mm

- ⊖ = End block 09A; mounting with and without mounting spar
- ⊕ = End block 10A; installation with mounting spar
- ⊙ = MSL 41 mounting spar
- F = Machine guideway
- P = Gauging points for alignment
- ⊗ = Required mating dimensions

- ⊖ = Reference mark position on LS 4x7  
 Two reference marks for measuring lengths  

70 ... 1020	1140 ... 2040
z = 35 mm	z = 45 mm
z <sub>1</sub> = ML - 70 mm	z <sub>1</sub> = ML - 90 mm
- ⊙ = Reference-mark position on LS 4x7C
- ⊗ = Compressed air inlet
- ⊕ = Beginning of measuring length ML
- ⇒ = Direction of scanning unit motion for output signals in accordance with interface description

LS 4x7 without mounting spar



LS 4x7 with mounting spar

Specifications	LS 487	LS 477							
<b>Measuring standard</b> Coefficient of linear expansion	Glass scale with DIADUR grating, grating period 20 µm $\alpha_{\text{therm}} \approx 8 \times 10^{-6} \text{ K}^{-1}$ (mounting type ○/⊙); <i>with mounting spar</i> : $\alpha_{\text{therm}} \approx 9 \times 10^{-6} \text{ K}^{-1}$ (mounting type ⊙)								
<b>Accuracy grade*</b>	±5 µm; ±3 µm								
<b>Measuring length ML*</b> in mm	Mounting spar* up to ML 1240 optional, necessary as of ML 1340 70 120 170 220 270 320 370 420 470 520 570 620 670 720 770 820 920 1020 1140 1240 1340 1440 1540 1640 1740 1840 2040								
Reference marks* LS 4x7  LS 4x7C	<ul style="list-style-type: none"> <li>Selectable with magnets every 50 mm</li> <li>One reference mark at midpoint of measuring length</li> <li>Two reference marks, each 35 mm (for ML ≤ 1020 mm) or 45 mm (for ML ≥ 1140 mm) from the beginning and end of the measuring length</li> </ul> Distance-coded								
<b>Interface</b>	~ 1 V <sub>PP</sub>		□ TTL						
Integrated interpolation* Signal period	– 20 µm		5-fold –		10-fold –		20-fold –		
Diagnostics interface	Analog		–						
Cutoff frequency –3 dB	≥ 160 kHz		–		–		–		
Scanning frequency* Edge separation a	–		100 kHz ≥ 0.5 µs	50 kHz ≥ 1 µs	100 kHz ≥ 0.25 µs	50 kHz ≥ 0.5 µs	25 kHz ≥ 1 µs	50 kHz ≥ 0.25 µs	25 kHz ≥ 0.5 µs
<b>Measuring step</b>	Depends on interpolation		1 µm <sup>1)</sup>		0.5 µm <sup>1)</sup>		0.25 µm <sup>1)</sup>		
<b>Electrical connection</b>	Separate adapter cable (1 m/3 m/6 m/9 m) connectible to mounting block								
Cable length <sup>2)</sup>	≤ 150 m		≤ 100 m						
Voltage supply without load	DC 5 V ±0.25 V/< 120 mA		DC 5 V ±0.25 V/< 140 mA						
<b>Traversing speed</b>	≤ 120 m/min		≤ 120 m/min	≤ 60 m/min	≤ 120 m/min	≤ 60 m/min	≤ 30 m/min	≤ 60 m/min	≤ 30 m/min
<b>Required moving force</b>	≤ 5 N								
<b>Vibration</b> 55 Hz to 2000 Hz <b>Shock</b> 11 ms <b>Acceleration</b>	Without mounting spar: ≤ 100 m/s <sup>2</sup> (EN 60068-2-6) With mounting spar, cable outlet at right: ≤ 200 m/s <sup>2</sup> , links: 100 m/s <sup>2</sup> (EN 60068-2-6) ≤ 300 m/s <sup>2</sup> (EN 60068-2-27) ≤ 100 m/s <sup>2</sup> in measuring direction								
<b>Operating temperature</b>	0 °C to 50 °C								
<b>Protection</b> EN 60529	IP53 when installed according to mounting instructions and information; IP64 with compressed air from DA 400								
<b>Mass</b>	0.4 kg + 0.5 kg/m measuring length								

\* Please select when ordering

<sup>1)</sup> After 4-fold evaluation in the subsequent electronics

<sup>2)</sup> With HEIDENHAIN cable

# LS 100 series

Incremental linear encoders with full-size scale housing

- High vibration resistance
- Reclining mounting possible

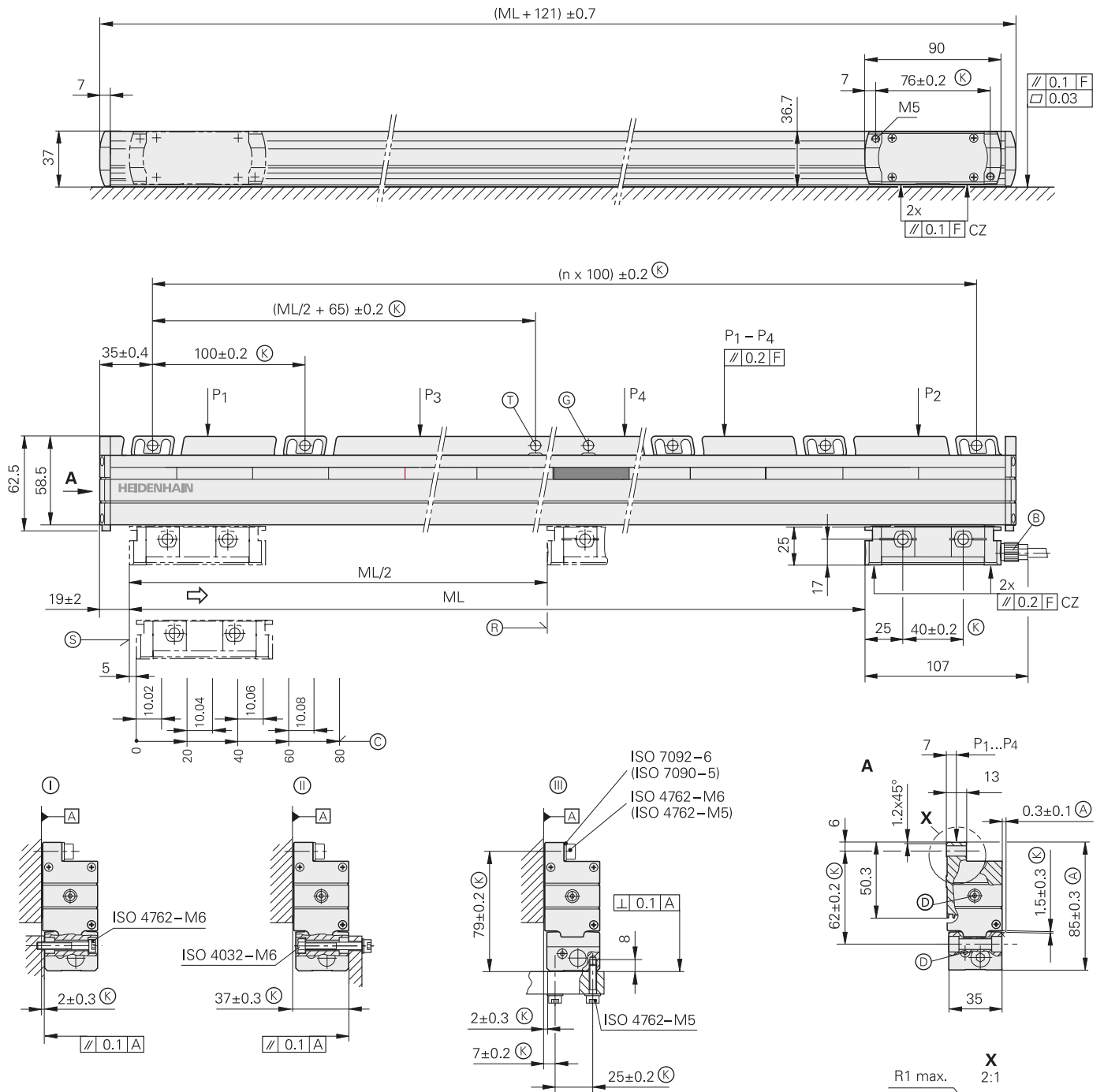

mm  
 Tolerancing ISO 8015  
 ISO 2768 - m H  
 < 6 mm: ±0.2 mm

- Ⓚ, Ⓛ, Ⓜ, Ⓝ = Mounting options
- F = Machine guideway
- P = Gauging points for alignment
- Ⓢ = Required mating dimensions
- ⓐ = Alternative mating dimensions
- Ⓟ = Cable connection usable at either end
- Ⓠ = Compressed air inlet usable at either end
- Ⓡ = Mechanical fixed point (to be preferred)
- Ⓢ = Mechanical fixed point, with spacing interval of 100 mm
- Ⓣ = Reference-mark position on LS 1x7
- Ⓤ = Reference-mark position on LS 1x7C
- Ⓥ = Beginning of measuring length ML
- Ⓦ = Mating surfaces
- ⇒ = Direction of scanning unit motion for output signals in accordance with interface description



Specifications	LS 187	LS 177															
<b>Measuring standard</b> Coefficient of linear expansion	Glass scale with DIADUR grating, grating period 20 µm $\alpha_{\text{therm}} \approx 8 \times 10^{-6} \text{ K}^{-1}$																
<b>Accuracy grade*</b>	±5 µm; ±3 µm																
<b>Measuring length ML*</b> in mm	140 1540	240 1640	340 1740	440 1840	540 2040	640 2240	740 2440	840 2640	940 2840	1040 3040	1140	1240	1340	1440			
Reference marks* LS 1x7 LS 1x7C	Selectable with magnets every 50 mm, standard setting: 1 reference mark in the center Distance-coded																
<b>Interface</b>	~ 1 V <sub>pp</sub>			□ TTL													
Integrated interpolation* Signal period	– 20 µm			5-fold –		10-fold –		20-fold –									
Diagnostics interface	Analog			–													
Cutoff frequency –3 dB	≥ 160 kHz			–		–		–									
Scanning frequency* Edge separation a	–			100 kHz ≥ 0.5 µs		50 kHz ≥ 1 µs		100 kHz ≥ 0.25 µs		50 kHz ≥ 0.5 µs		25 kHz ≥ 1 µs		50 kHz ≥ 0.25 µs		25 kHz ≥ 0.5 µs	
<b>Measuring step</b>	Depends on interpolation			1 µm <sup>1)</sup>		0.5 µm <sup>1)</sup>		0.25 µm <sup>1)</sup>									
<b>Electrical connection</b>	Separate adapter cable (1 m/3 m/6 m/9 m) connectible to mounting block																
Cable length <sup>2)</sup>	≤ 150 m			≤ 100 m													
Voltage supply without load	DC 5 V ±0.25 V/< 120 mA			DC 5 V ±0.25 V/< 140 mA													
<b>Traversing speed</b>	≤ 120 m/min			≤ 120 m/min		≤ 60 m/min		≤ 120 m/min		≤ 60 m/min		≤ 30 m/min		≤ 60 m/min		≤ 30 m/min	
<b>Required moving force</b>	≤ 4 N																
<b>Vibration</b> 55 Hz to 2000 Hz <b>Shock</b> 11 ms <b>Acceleration</b>	≤ 200 m/s <sup>2</sup> (EN 60068-2-6) ≤ 400 m/s <sup>2</sup> (EN 60068-2-27) ≤ 60 m/s <sup>2</sup> in measuring direction																
<b>Operating temperature</b>	0 °C to 50 °C																
<b>Protection</b> EN 60529	IP53 when mounted according to the instructions and mounting information IP64 if compressed air is connected via DA 400																
<b>Mass</b>	0.4 kg + 2.3 kg/m measuring length																

\* Please select when ordering

<sup>1)</sup> After 4-fold evaluation in the subsequent electronics

<sup>2)</sup> With HEIDENHAIN cable

# LB 382 up to 3040 mm measuring length (single-section housing)

Incremental linear encoders with full-size scale housing

- Reclining mounting possible
- Also available in mirrored version (mating dimensions upon request)

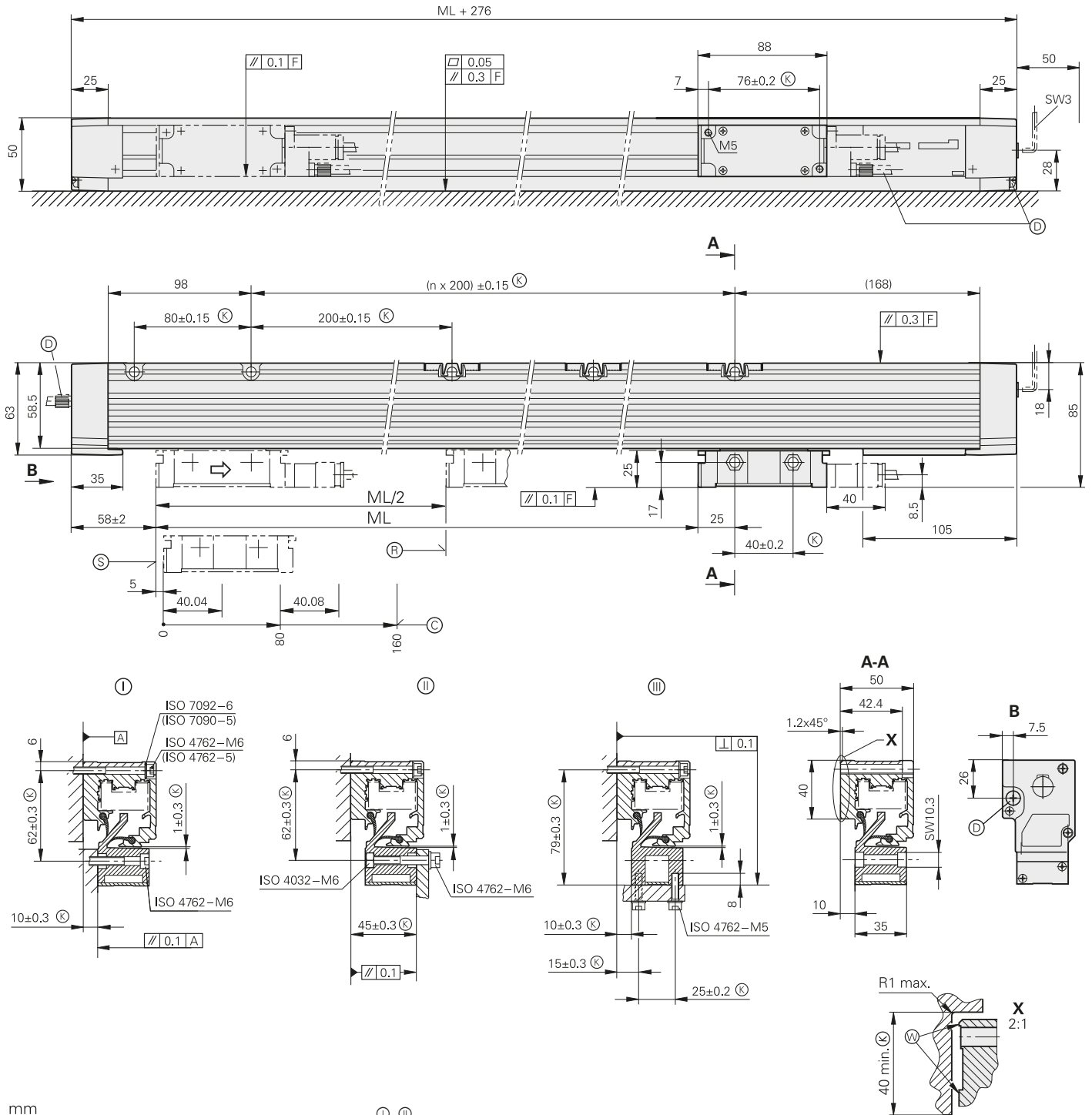

mm  
 Tolerancing ISO 8015  
 ISO 2768 - m H  
 < 6 mm:  $\pm 0.2$  mm

- ①, ②, ③ = Mounting options
- F = Machine guideway
- (K) = Required mating dimensions
- (D) = Compressed air inlet
- (R) = Reference-mark position on LB 3x2
- (C) = Reference-mark position on LB 3x2C
- (S) = Beginning of measuring length ML
- (W) = Mating surfaces
- ⇒ = Direction of scanning unit motion for output signals in accordance with interface description





<b>Specifications</b>	<b>LB 382</b> up to ML 3040 mm
<b>Measuring standard</b> Coefficient of linear expansion	Rustproof steel scale tape with AURODUR graduation, grating period 40 µm $\alpha_{\text{therm}} \approx 10 \times 10^{-6} \text{ K}^{-1}$
<b>Accuracy grade</b>	±5 µm
<b>Measuring length ML*</b> in mm	Single-section housing 440 640 840 1040 1240 1440 1640 1840 2040 2240 2440 2640 2840 3040
Reference mark* <i>LB 382</i> <i>LB 382C</i>	Selectable by selector plate every 50 mm, standard setting: 1 reference mark in the center Distance-coded
<b>Interface</b>	~ 1 V <sub>PP</sub>
Signal period	40 µm
Diagnostics interface	Analog
Cutoff frequency -3 dB	≥ 250 kHz
<b>Electrical connection</b>	Separate adapter cable (1 m/3 m/6 m/9 m) connectible to mounting block
Cable length <sup>1)</sup>	≤ 150 m
Voltage supply without load	DC 5 V ±0.25 V / < 150 mA
<b>Traversing speed</b>	≤ 120 m/min (max. acceleration in measuring direction ≤ 60 m/s <sup>2</sup> )
<b>Required moving force</b>	≤ 15 N
<b>Vibration</b> 55 Hz to 2000 Hz <b>Shock</b> 11 ms	≤ 300 m/s <sup>2</sup> (EN 60068-2-6) ≤ 300 m/s <sup>2</sup> (EN 60068-2-27)
<b>Operating temperature</b>	0 °C to 50 °C
<b>Protection</b> EN 60529	IP53 when mounted according to the instructions and mounting information IP64 if compressed air is connected via DA 400
<b>Mass</b>	1.3 kg + 3.6 kg/m measuring length

\* Please select when ordering

<sup>1)</sup> With HEIDENHAIN cable

# LB 382 up to 30040 mm measuring length (multi-section housing)



Incremental linear encoders with full-size scale housing

- Measuring lengths up to 30 m (to 72 m upon request)
- Reclining mounting possible
- Also available in mirrored version (mating dimensions upon request)

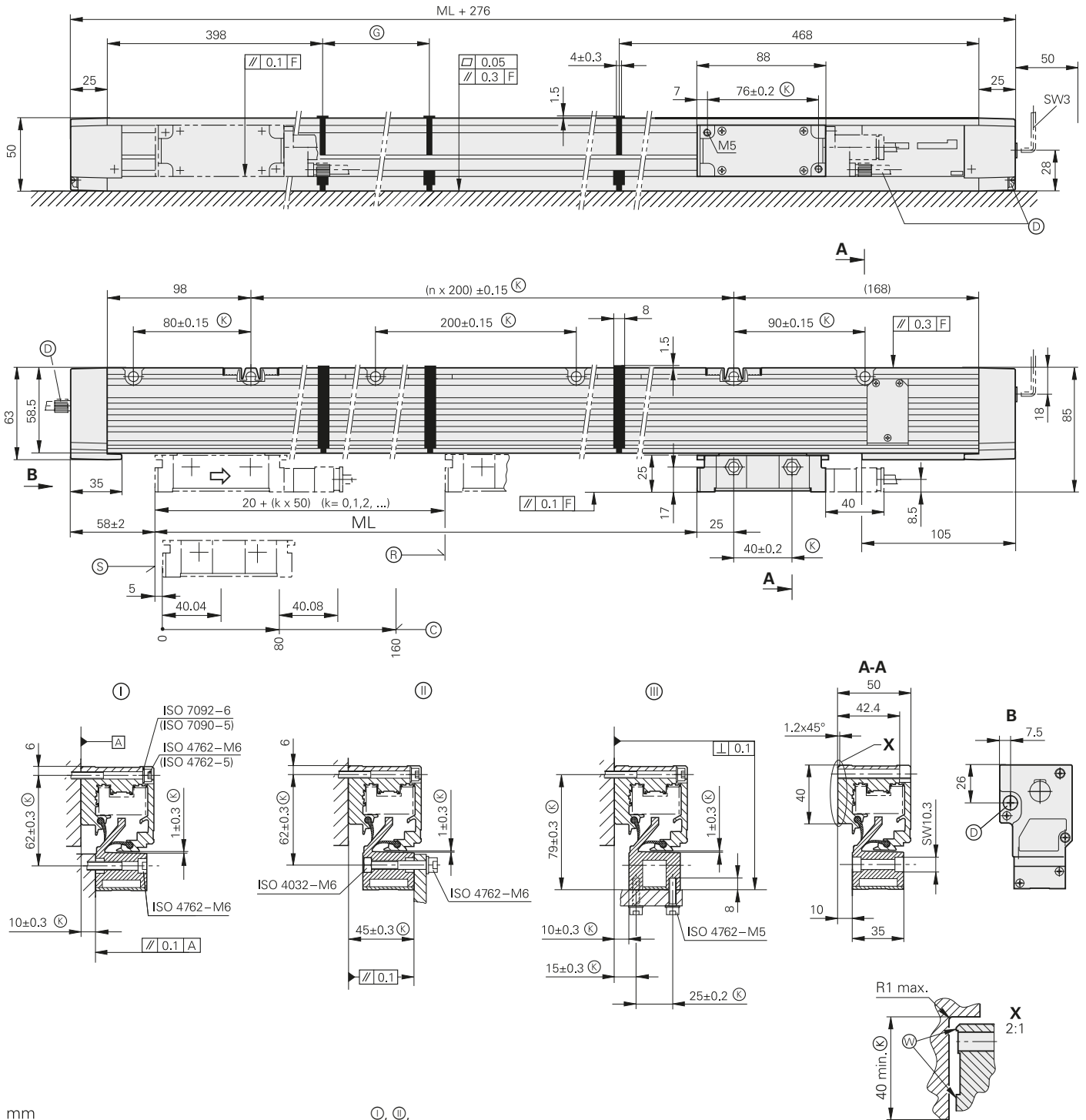

mm  
 Tolerancing ISO 8015  
 ISO 2768 - m H  
 < 6 mm: ±0.2 mm

- ①, ②, ③ = Mounting options
- F = Machine guideway
- (K) = Required mating dimensions
- (D) = Compressed air inlet
- (R) = Reference-mark position on LB 3x2
- (C) = Reference-mark position on LB 3x2C
- (S) = Beginning of measuring length ML
- (A) = Housing section lengths
- (W) = Mating surfaces
- ⇒ = Direction of scanning unit motion for output signals in accordance with interface description



Specifications	LB 382 from ML 3240 mm
<b>Measuring standard</b> Coefficient of linear expansion	Rustproof steel scale tape with AURODUR graduation, grating period 40 µm Same as machine main casting
<b>Accuracy grade</b>	±5 µm
<b>Measuring length ML*</b>	Kit with single-section AURODUR steel tape and housing sections for measuring lengths from 3240 mm to 30040 mm in 200 mm steps (up to 72040 mm upon request) Housing section lengths: 1000 mm, 1200 mm, 1400 mm, 1600 mm, 1800 mm, 2000 mm
Reference mark* <i>LB 382</i> <i>LB 382 C</i>	Selectable by selector plate every 50 mm Distance-coded
<b>Interface</b>	~ 1 V <sub>pp</sub>
Signal period	40 µm
Diagnostics interface	Analog
Cutoff frequency -3 dB	≥ 250 kHz
<b>Electrical connection</b>	Separate adapter cable (1 m/3 m/6 m/9 m) connectible to mounting block
Cable length <sup>1)</sup>	≤ 150 m
Voltage supply without load	DC 5 V ±0.25 V / < 150 mA
<b>Traversing speed</b>	≤ 120 m/min (max. acceleration in measuring direction ≤ 60 m/s <sup>2</sup> )
<b>Required moving force</b>	≤ 15 N
<b>Vibration</b> 55 Hz to 2000 Hz <b>Shock</b> 11 ms	≤ 300 m/s <sup>2</sup> (EN 60068-2-6) ≤ 300 m/s <sup>2</sup> (EN 60068-2-27)
<b>Operating temperature</b>	0 °C to 50 °C
<b>Protection</b> EN 60529	IP53 when mounted according to the instructions and mounting information IP64 if compressed air is connected via DA 400
<b>Mass</b>	1.3 kg + 3.6 kg/m measuring length

\* Please select when ordering

<sup>1)</sup> With HEIDENHAIN cable

# Interfaces

## Incremental signals $\sim 1 V_{PP}$

HEIDENHAIN encoders with  $\sim 1 V_{PP}$  interface provide highly interpolable voltage signals.

The sinusoidal **incremental signals** A and B are phase-shifted by  $90^\circ$  elec. and have amplitudes of typically  $1 V_{PP}$ . The illustrated sequence of output signals—with B lagging A—applies for the direction of motion shown in the dimension drawing.

The **reference mark signal** R has an unambiguous assignment to the incremental signals. The output signal might be somewhat lower next to the reference mark.

Comprehensive descriptions of all available interfaces as well as general electrical information is included in the *Interfaces of HEIDENHAIN Encoders* brochure.

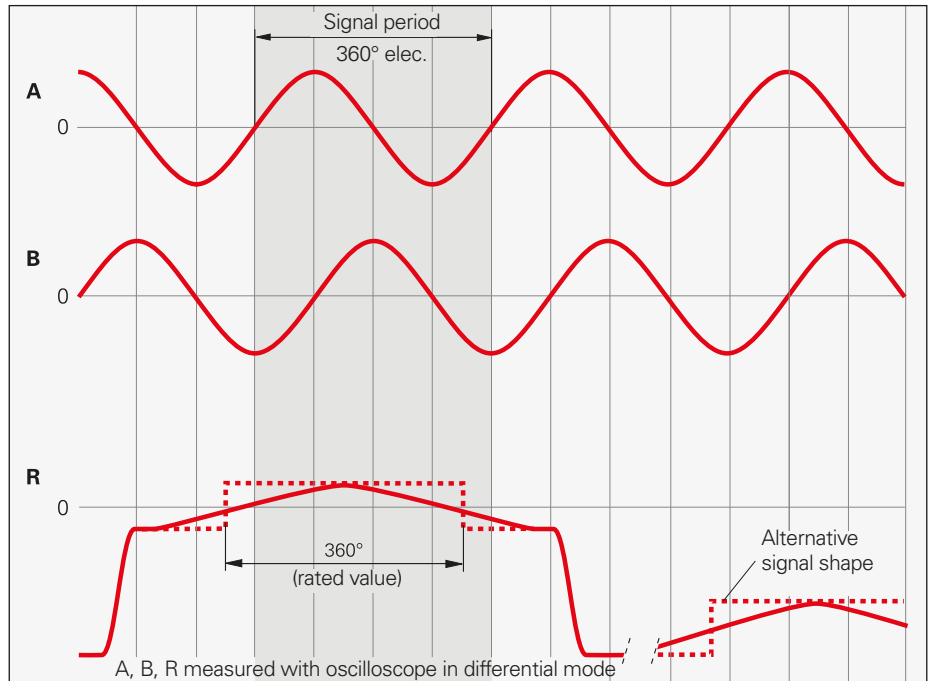

### Pin layout

12-pin coupling M23					12-pin connector M23									
15-pin D-sub connector					15-pin D-sub connector									
For HEIDENHAIN controls and IK 220					For encoders or IK 215									
	Voltage supply				Incremental signals						Other signals			
	12	2	10	11	5	6	8	1	3	4	9	7	/	
	1	9	2	11	3	4	6	7	10	12	5/8/13/15	14	/	
	4	12	2	10	1	9	3	11	14	7	5/6/8/15	13	/	
	$U_P$	Sensor <sup>1)</sup> $U_P$	0V	Sensor <sup>1)</sup> 0V	A+	A-	B+	B-	R+	R-	Vacant	Vacant	Vacant	
	Brown/ Green	Blue	White/ Green	White	Brown	Green	Gray	Pink	Red	Black	/	Violet	Yellow	

**Cable shield** connected to housing;  $U_P$  = power supply voltage

**Sensor:** The sensor line is connected in the encoder with the corresponding power line

Vacant pins or wires must not be used!

<sup>1)</sup> LIDA 2xx: Vacant

# Incremental signals $\square$ TTL

HEIDENHAIN encoders with  $\square$ TTL interface incorporate electronics that digitize sinusoidal scanning signals with or without interpolation.

The **incremental signals** are transmitted as the square-wave pulse trains  $U_{a1}$  and  $U_{a2}$ , phase-shifted by  $90^\circ$  elec. The **reference mark signal** consists of one or more reference pulses  $U_{a0}$ , which are gated with the incremental signals. In addition, the integrated electronics produce their **inverted signals**  $\overline{U_{a1}}$ ,  $\overline{U_{a2}}$  and  $\overline{U_{a0}}$  for noise-proof transmission. The illustrated sequence of output signals—with  $U_{a2}$  lagging  $U_{a1}$ —applies to the direction of motion shown in the dimension drawing.

The **fault detection signal**  $\overline{U_{aS}}$  indicates fault conditions such as an interruption in the supply lines, failure of the light source, etc.

The distance between two successive edges of the incremental signals  $U_{a1}$  and  $U_{a2}$  through 1-fold, 2-fold or 4-fold evaluation is one **measuring step**.

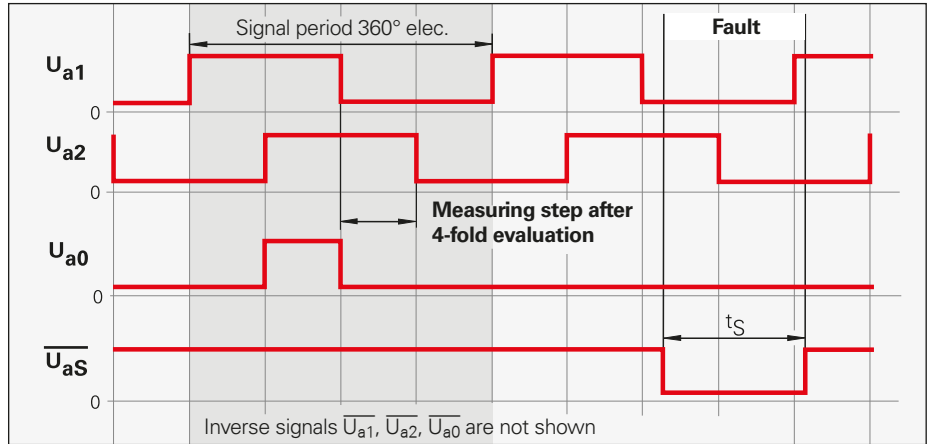

Comprehensive descriptions of all available interfaces as well as general electrical information is included in the *Interfaces of HEIDENHAIN Encoders* brochure.

## Pin layout

12-pin coupling M23				12-pin connector M23									
15-pin D-sub connector For HEIDENHAIN controls and IK 220				15-pin D-sub connector For encoder or PWM 20									
	Voltage supply			Incremental signals						Other signals			
	12	2	10	11	5	6	8	1	3	4	7	/	9 <sup>3)</sup>
	1	9	2	11	3	4	6	7	10	12	14	8/13/15	5
	4	12	2	10	1	9	3	11	14	7	13	5/6/8	15 <sup>3)</sup>
	$U_P$	Sensor <sup>1)</sup> $U_P$	0V	Sensor <sup>1)</sup> 0V	$U_{a1}$	$\overline{U_{a1}}$	$U_{a2}$	$\overline{U_{a2}}$	$U_{a0}$	$\overline{U_{a0}}$	$\overline{U_{aS}}$ <sup>2)</sup>	Vacant	Vacant
	Brown/ Green	Blue	White/ Green	White	Brown	Green	Gray	Pink	Red	Black	Violet	/	Yellow

**Cable shield** connected to housing;  $U_P$  = power supply voltage

**Sensor:** The sensor line is connected in the encoder with the corresponding power line

Vacant pins or wires must not be used!

<sup>1)</sup> LIDA 2xx: Vacant

<sup>2)</sup> ERO 14xx: Vacant

<sup>3)</sup> **Exposed linear encoders:** switchover TTL/11  $\mu A_{PP}$  for PWT, otherwise vacant

# Interfaces

## Position values

The EnDat interface is a digital, **bidirectional** interface for encoders. It is capable both of transmitting **position values** as well as transmitting or updating information stored in the encoder, or saving new information. Thanks to the **serial transmission method**, only **four signal lines** are required. The DATA data is transmitted in **synchronism** with the CLOCK signal from the subsequent electronics. The type of transmission (position values, parameters, diagnostics, etc.) is selected through mode commands that the subsequent electronics send to the encoder. Some functions are available only with EnDat 2.2 mode commands.



Comprehensive descriptions of all available interfaces as well as general electrical information are included in the *Interfaces of HEIDENHAIN Encoders* brochure.

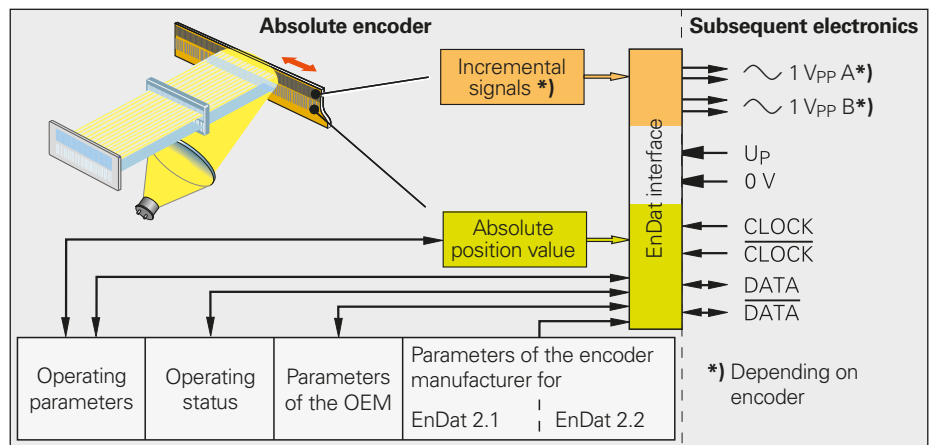

Ordering designation	Command set	Incremental signals
<b>EnDat01</b>	EnDat 2.1 or EnDat 2.2	With
EnDat21		Without
EnDat02	EnDat 2.2	With
<b>EnDat22</b>	EnDat 2.2	Without

Versions of the EnDat interface



### Pin layout

8-pin coupling, M12								
	Voltage supply				Absolute position values			
	8	2	5	1	3	4	7	6
	Up	Sensor Up	0V	Sensor 0V	DATA	DATA	CLOCK	CLOCK
	Brown/Green	Blue	White/Green	White	Gray	Pink	Violet	Yellow

17-pin coupling, M23						15-pin D-sub connector For HEIDENHAIN controls and IK 220							
	Power supply					Incremental signals <sup>1)</sup>				Absolute position values			
	7	1	10	4	11	15	16	12	13	14	17	8	9
	1	9	2	11	13	3	4	6	7	5	8	14	15
	Up	Sensor Up	0V	Sensor 0V	Internal shield	A+	A-	B+	B-	DATA	DATA	CLOCK	CLOCK
	Brown/Green	Blue	White/Green	White	/	Green/Black	Yellow/Black	Blue/Black	Red/Black	Gray	Pink	Violet	Yellow

**Cable shield** connected to housing; **Up** = power supply voltage

**Sensor:** The sensor line is connected in the encoder with the corresponding power line  
Vacant pins or wires must not be used!

<sup>1)</sup> Only with ordering designations EnDat01 and EnDat02

# Fanuc, Mitsubishi and Siemens pin layout

## Fanuc pin layout







HEIDENHAIN encoders with the code letter F after the model designation are suited for connection to Fanuc controls with

### • Fanuc Serial Interface – $\alpha$ Interface

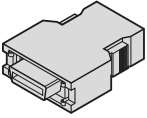
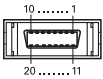
Ordering designation: Fanuc02  
normal and high speed, two-pair transmission

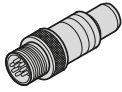
### • Fanuc Serial Interface – $\alpha$ i interface

Ordering designation: Fanuc05  
high speed, one-pair transmission  
Contains  $\alpha$  interface (normal and high speed, two-pair transmission)

20-pin Fanuc connector					8-pin coupling, M12				
									
	Voltage supply					Absolute position values			
	<b>9</b>	<b>18/20</b>	<b>12</b>	<b>14</b>	<b>16</b>	<b>1</b>	<b>2</b>	<b>5</b>	<b>6</b>
	<b>8</b>	<b>2</b>	<b>5</b>	<b>1</b>	–	<b>3</b>	<b>4</b>	<b>7</b>	<b>6</b>
	<b>U<sub>P</sub></b>	<b>Sensor</b> U <sub>P</sub>	<b>0V</b>	<b>Sensor</b> 0V	<b>Shield</b>	<b>Serial Data</b>	<b>Serial Data</b>	<b>Request</b>	<b>Request</b>
	Brown/ Green	Blue	White/ Green	White	–	Gray	Pink	Violet	Yellow

**Cable shield** connected to housing; **U<sub>P</sub>** = power supply voltage

**Sensor:** The sensor line is connected in the encoder with the corresponding power line.

Vacant pins or wires must not be used!









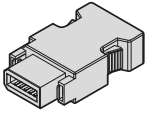
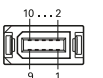

## Mitsubishi pin layout

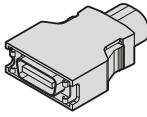
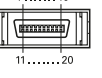
HEIDENHAIN encoders with the code letter M after the model designation are suited for connection to Mitsubishi controls with

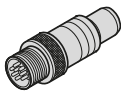
### Mitsubishi high speed interface

- Ordering designation: Mitsu01  
Two-pair transmission

- Ordering designation: Mit02-4  
Generation 1, two-pair transmission
- Ordering designation: Mit02-2  
Generation 1, one-pair transmission
- Ordering designation: Mit03-4  
Generation 2, two-pair transmission

10-pin Mitsubishi connector			20-pin Mitsubishi connector			8-pin coupling, M12			
									
	Voltage supply					Absolute position values			
	<b>10-pin</b>	<b>1</b>	–	<b>2</b>	–	<b>7</b>	<b>8</b>	<b>3</b>	<b>4</b>
	<b>20-pin</b>	<b>20</b>	<b>19</b>	<b>1</b>	<b>11</b>	<b>6</b>	<b>16</b>	<b>7</b>	<b>17</b>
	<b>8</b>	<b>2</b>	<b>5</b>	<b>1</b>		<b>3</b>	<b>4</b>	<b>7</b>	<b>6</b>
	<b>U<sub>P</sub></b>	<b>Sensor</b> U <sub>P</sub>	<b>0V</b>	<b>Sensor</b> 0V	<b>Serial Data</b>	<b>Serial Data</b>	<b>Request Frame</b>	<b>Request Frame</b>	
	Brown/Green	Blue	White/Green	White	Gray	Pink	Violet	Yellow	

**Cable shield** connected to housing; **U<sub>P</sub>** = power supply voltage

**Sensor:** The sensor line is connected in the encoder with the corresponding power line.







Vacant pins or wires must not be used!

**Siemens pin layout**

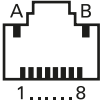
HEIDENHAIN encoders with the code letter S after the model designation are suited for connection to Siemens controls with **DRIVE-CLiQ interface**

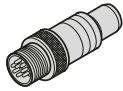
- Ordering designation DQ01

DRIVE-CLiQ is a registered trademark of SIEMENS AG.

RJ45 connector			8-pin coupling, M12			
						
	Voltage supply		Absolute position values			
			Transmit data		Receive data	
	<b>A</b>	<b>B</b>	<b>3</b>	<b>6</b>	<b>1</b>	<b>2</b>
	<b>1</b>	<b>5</b>	<b>7</b>	<b>6</b>	<b>3</b>	<b>4</b>
	<b>U<sub>p</sub></b>	<b>0V</b>	<b>TXP</b>	<b>TXN</b>	<b>RXP</b>	<b>RXN</b>

**Cable shield** connected to housing; **U<sub>p</sub>** = power supply voltage



# Connecting elements and cables

## General information

**Connector (insulated):** Connecting element with coupling ring; available with male or female contacts.

Symbols



**M12**

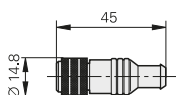

**M23**

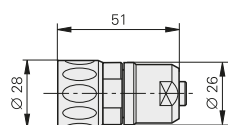

**Flange socket:** Permanently mounted on the encoder or a housing, with external thread (like the coupling), and available with male or female contacts.

Symbols



**M23**

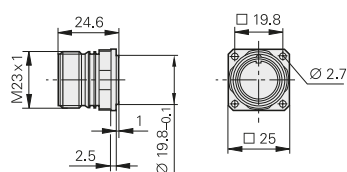

**D-sub connector:** For HEIDENHAIN controls, counters and IK absolute value cards.

Symbols

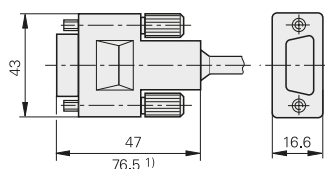

<sup>1)</sup> With integrated interpolation electronics

**Coupling insulated:** Connecting element with external thread. Available with male or female contacts.

Symbols



**On the adapter cable**

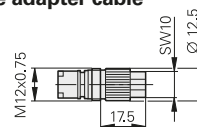

**M12**

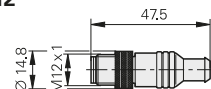

**M23**

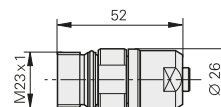

**Mounted coupling with central fastening**

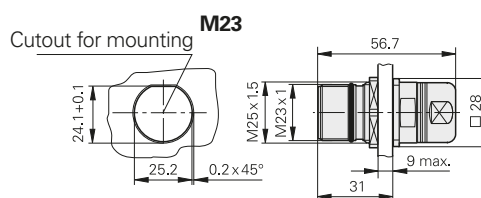

**Mounted coupling with flange**

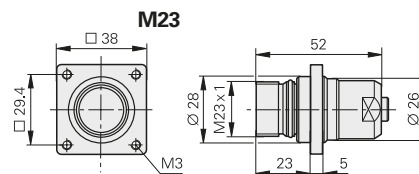

The pins on connectors are **numbered** in the direction opposite to those on couplings or flange sockets, regardless of whether the connecting elements have

male contacts or



female contacts.



When engaged, the connections provide **protection** to IP67 (D-sub connector: IP50; RJ-45: IP20; EN 60529). When not engaged, there is no protection.

**Accessory for flange sockets and M23 mounted couplings**





**Bell seal**

ID 266526-01

**Threaded metal dust cap**



ID 219926-01

# Adapter cables

<b>For incremental linear encoders</b>		<b>Cable Ø</b>	<b>LB 382</b>	<b>LF 185/485 LS 187/177 LS 487/477</b>
<b>PUR</b> [6(2 x 0.19 mm <sup>2</sup> ); A <sub>P</sub> = 0.19 mm <sup>2</sup> ]				
<b>Adapter cables</b> With M23 coupling (male, 12-pin)		6 mm	310128-xx	360645-xx
<b>Adapter cables</b> Without connector		6 mm	310131-xx	354319-xx
<b>Adapter cables</b> With M23 connector (male), 12-pin		6 mm 4.5 mm	310127-xx –	344228-xx 352611-xx <sup>1)</sup>
<b>Armored adapter cable</b> With M23 connector (male), 12-pin		10 mm	310126-xx	344451-xx
<b>Adapter cables</b> With 15-pin D-sub connector (female)		6 mm	298429-xx	360974-xx



A<sub>P</sub> = Cross section of power supply lines

<sup>1)</sup> **PUR** [4(2 x 0.05 mm<sup>2</sup>) + (4 x 0.14 mm<sup>2</sup>); A<sub>P</sub> = 0.14 mm<sup>2</sup>]

<b>For absolute linear encoders – EnDat with incremental signals</b>		<b>Cable Ø</b>	<b>LC 185 LC 485 LC 281</b>
<b>PUR</b> [6(2 x 0.19 mm <sup>2</sup> ); A <sub>P</sub> = 0.19 mm <sup>2</sup> ]			
<b>Adapter cable</b> With M23 coupling (male), 17-pin		6 mm	533631-xx
<b>Armored adapter cable</b> With M23 coupling (male), 17-pin		10 mm	558362-xx
<b>Adapter cable</b> With 15-pin D-sub connector (female)		6 mm	558714-xx

**Available cable lengths:** 1 m/3 m/6 m/9 m



A<sub>P</sub> = Cross section of power supply lines

<b>For absolute linear encoders – EnDat without incremental signals<sup>1)</sup></b>		<b>Cable Ø</b>	<b>LC 115 LC 415 LC 211</b>
<b>PUR</b> [4(2 x 0.14 mm <sup>2</sup> ); A <sub>P</sub> = 0.14 mm <sup>2</sup> ]			
<b>Adapter cable</b> With M12 coupling (male), 8-pin		4.5 mm	533661-xx
<b>Armored adapter cable</b> With M12 coupling (male), 8-pin		10 mm	550678-xx
<b>Adapter cable</b> With 25-pin D-sub connector (female)		6 mm	1083369-xx <sup>2)</sup>





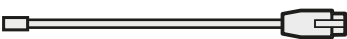

A<sub>P</sub> = Cross section of power supply lines

<sup>1)</sup> **Note for safety-related applications:** Only completely assembled HEIDENHAIN cables are qualified.  
Be sure to exchange connectors or modify cables only after consultation with HEIDENHAIN Traunreut.









<sup>2)</sup> **PUR** [2(2 x 0.9 mm<sup>2</sup>) + (2 x 0.14 mm<sup>2</sup>); A<sub>P</sub> = 0.14 mm<sup>2</sup>]

<b>For absolute linear encoders – Siemens</b> <sup>1)</sup> PUR [2(2 x 0.17 mm <sup>2</sup> ) + (2 x 0.24 mm <sup>2</sup> )]; A <sub>P</sub> = 0.24 mm <sup>2</sup>		<b>Cable Ø</b>	<b>LC 195 S</b> <b>LC 495 S</b>
<b>Adapter cables</b> With M12 coupling (male), 8-pin		6.8 mm	805452-xx
<b>Armored adapter cable</b> With M12 coupling (male), 8-pin		11.1 mm	816675-xx
<b>Adapter cables</b> With Siemens connector, RJ45 (IP20)		6.8 mm	805375-xx

<sup>1)</sup> **Note for safety-related applications:** Only completely assembled HEIDENHAIN cables are qualified.  
Be sure to exchange connectors or modify cables only after consultation with HEIDENHAIN Traunreut.

<b>For absolute linear encoders – Fanuc</b> PUR [4(2 x 0.14 mm <sup>2</sup> )]; A <sub>P</sub> = 0.14 mm <sup>2</sup>		<b>Cable Ø</b>	<b>LC 195 F</b> <b>LC 495 F</b> <b>LC 291 F</b>
<b>Adapter cables</b> With M23 coupling (male), 17-pin		6 mm 4.5 mm	– 547300-xx
<b>Armored adapter cable</b> With M23 coupling (male), 17-pin		10 mm	555541-xx
<b>Adapter cables</b> With M12 coupling (male), 8-pin		4.5 mm	533661-xx
<b>Armored adapter cable</b> With M12 coupling (male), 8-pin		10 mm	550678-xx
<b>Adapter cables</b> With Fanuc connector (female), 20-pin		4.5 mm	545547-xx
<b>Armored adapter cable</b> With Fanuc connector (male), 20-pin		10 mm	551027-xx

**Available cable lengths:** 1 m/3 m/6 m/9 m  
A<sub>P</sub> = Cross section of power supply lines

<b>For absolute linear encoders – Mitsubishi</b> PUR [4(2 x 0.14 mm <sup>2</sup> )]; A <sub>P</sub> = 0.14 mm <sup>2</sup>		<b>Cable Ø</b>	<b>LC 195 M</b> <b>LC 495 M</b> <b>LC 291 M</b>
<b>Adapter cable</b> With M23 coupling (male), 17-pin		6 mm 4.5 mm	– 547300-xx
<b>Armored adapter cable</b> With M23 coupling (male), 17-pin		10 mm	555541-xx
<b>Adapter cable</b> With M12 coupling (male), 8-pin		4.5 mm	533661-xx
<b>Armored adapter cable</b> With M12 coupling (male), 8-pin		10 mm	550678-xx
<b>Adapter cable</b> With Mitsubishi connector (female), 10-pin		4.5 mm	640915-xx
With Mitsubishi connector (male), 20-pin		4.5 mm	599685-xx
<b>Armored adapter cable</b> With Mitsubishi connector (female), 10-pin		10 mm	640916-xx
With Mitsubishi connector (male), 20-pin		10 mm	599688-xx

**Available cable lengths:** 1 m/3 m/6 m/9 m  
A<sub>P</sub> = Cross section of power supply lines

# Connecting cables $\sim 1 V_{PP}$

TTL  
EnDat



12-pin M23    17-pin M23    8-pin M12

		$\sim 1 V_{PP}$ TTL	EnDat with incremental signals SSI	EnDat without incremental signals <sup>1)</sup>
<b>PUR connecting cables</b>		<b>8-pin:</b> $[(4 \times 0.14 \text{ mm}^2) + (4 \times 0.34 \text{ mm}^2)]; A_P = 0.34 \text{ mm}^2$ <b>12-pin:</b> $[4(2 \times 0.14 \text{ mm}^2) + (4 \times 0.5 \text{ mm}^2)]; A_P = 0.5 \text{ mm}^2$ <b>17-pin:</b> $[(4 \times 0.14 \text{ mm}^2) + 4(2 \times 0.14 \text{ mm}^2) + (4 \times 0.5 \text{ mm}^2)]; A_P = 0.5 \text{ mm}^2$		
			$\varnothing 6 \text{ mm}$	$\varnothing 8 \text{ mm}$
			$\varnothing 8 \text{ mm}$	$\varnothing 8 \text{ mm}$
<b>Complete</b> With coupling (female) and connector (male)		298400-xx	–	–
<b>Complete</b> With connector (female) and coupling (male)		298401-xx	323897-xx	368330-xx
<b>Complete</b> With connector (female) and connector (male)		298399-xx	–	–
<b>Complete</b> With connector (female) and D-sub connector (female) for IK 220		310199-xx	332115-xx	533627-xx
<b>Complete</b> With connector (female) and D-sub connector (male) for IK 115/IK 215		310196-xx	324544-xx	524599-xx
<b>With one connector</b> With coupling (female)		298402-xx	–	–
<b>With one connector</b> With connector (female)		309777-xx	309778-xx	634265-xx
<b>Cable only</b>		816317-xx	816322-xx	816329-xx
<b>Mating element on connecting cable to connector on encoder cable</b>	<b>Connector (female)</b> For cable $\varnothing 8 \text{ mm}$ 	291697-05	291697-26	–
<b>Connector on connecting cable</b> For connection to the subsequent electronics	<b>Connector (male)</b> For cable $\varnothing 4.5 \text{ mm}$ $\varnothing 8 \text{ mm}$ $\varnothing 6 \text{ mm}$ 	291697-06 291697-08 291697-07	291697-27	–
<b>Coupling on connecting cable</b>	<b>Coupling (male)</b> For cable $\varnothing 4.5 \text{ mm}$ $\varnothing 6 \text{ mm}$ $\varnothing 8 \text{ mm}$ 	291698-14 291698-03 291698-04	291698-25 291698-26 291698-27	–
<b>Flange socket</b> For mounting on the subsequent electronics	<b>Flange socket (female)</b> 	315892-08	315892-10	–

$A_P$  = Cross section of power supply lines



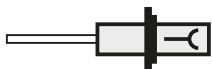
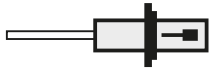

<sup>1)</sup> **Note for safety-related applications:** Only completely assembled HEIDENHAIN cables are qualified. Be sure to exchange connectors or modify cables only after consultation with HEIDENHAIN Traunreut.



12-pin M23    17-pin M23



		$\sim 1V_{PP}$ $\square$ TTL	EnDat with incremental signals <b>SSI</b>	
<b>Mounted couplings</b>	<b>With flange (female)</b> 	$\varnothing$ 6 mm $\varnothing$ 8 mm	291698-17 291698-07	291698-35
	<b>With flange (male)</b> 	$\varnothing$ 6 mm $\varnothing$ 8 mm	291698-08 291698-31	291698-41 291698-29
	<b>With central fastening (male)</b> 	$\varnothing$ 6 mm to 10 mm	741045-01	741045-02
<b>Adapter <math>\sim 1V_{PP}/11\mu A_{PP}</math></b> For converting the $1V_{PP}$ signals to $11\mu A_{PP}$ ; M23 connector (female), 12-pin and M23 connector (male), 9-pin		364914-01	–	

A<sub>P</sub> = Cross section of power supply lines

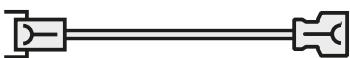
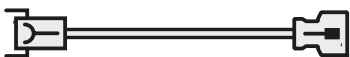
# Connecting cables Fanuc Mitsubishi Siemens

		Cable	Fanuc	Mitsubishi
<b>PUR connecting cable for M23 connecting elements</b>				
<b>Complete</b> With M23 connector (female), 17-pin, and Fanuc connector [[2 x 2 x 0.14 mm <sup>2</sup> ) + (4 x 1 mm <sup>2</sup> )]; A <sub>P</sub> = 1 mm <sup>2</sup>		Ø 8 mm	534855-xx	–
<b>Complete</b> With M23 connector (female), 17-pin, and Mitsubishi connector, 20-pin [[2 x 2 x 0.14 mm <sup>2</sup> ) + (4 x 0.5 mm <sup>2</sup> )]; A <sub>P</sub> = 0.5 mm <sup>2</sup>		Ø 6 mm	–	367958-xx
<b>Complete</b> With M23 connector (female), 17-pin, and Mitsubishi connector, 10-pin [[2 x 2 x 0.14 mm <sup>2</sup> ) + (4 x 1 mm <sup>2</sup> )]; A <sub>P</sub> = 1 mm <sup>2</sup>		Ø 8 mm	–	573661-xx
<b>Cable only</b> [[2 x 2 x 0.14 mm <sup>2</sup> ) + (4 x 1 mm <sup>2</sup> )]; A <sub>P</sub> = 1 mm <sup>2</sup>		Ø 8 mm	816327-xx	

		Cable	Fanuc	Mitsubishi
<b>PUR connecting cable for M12 connecting element</b> [(1 x 4 x 0.14 mm <sup>2</sup> ) + (4 x 0.34 mm <sup>2</sup> )]; A <sub>P</sub> = 0.34 mm <sup>2</sup>				
<b>Complete</b> With M12 connector (female), 8-pin, and Fanuc connector		Ø 6 mm	646807-xx	–
<b>Complete</b> With M12 connector (female), 8-pin, and Mitsubishi connector, 20-pin		Ø 6 mm	–	646806-xx
<b>Complete</b> With M12 connector (female), 8-pin, and Mitsubishi connector, 10-pin		Ø 6 mm	–	647314-xx

		Cable	Siemens <sup>1)</sup>
<b>PUR connecting cable for M12 connecting element</b> [2(2 x 0.17 mm <sup>2</sup> ) + (2 x 0.24 mm <sup>2</sup> )]; A <sub>P</sub> = 0.24 mm <sup>2</sup>			
<b>Complete</b> With M12 connector (female), 8-pin, and M12 coupling (male), 8-pin		Ø 6.8 mm	822504-xx
<b>Complete</b> With 8-pin M12 connector (female) and Siemens RJ45 connector (IP67) Cable length: 1 m		Ø 6.8 mm	1094652-01
<b>Complete</b> With M12 connector (female), 8-pin, and Siemens RJ45 connector (IP20)		Ø 6.8 mm	1093042-xx

A<sub>P</sub> = Cross section of power supply lines

<sup>1)</sup> **Note for safety-related applications:** Only completely assembled HEIDENHAIN cables are qualified.  
Be sure to exchange connectors or modify cables only after consultation with HEIDENHAIN Traunreut.

# Diagnostic and testing equipment

HEIDENHAIN encoders provide all information necessary for commissioning, monitoring and diagnostics. The type of available information depends on whether the encoder is incremental or absolute and which interface is used.

Incremental encoders mainly have 1 V<sub>PP</sub>, TTL or HTL interfaces. TTL and HTL encoders monitor their signal amplitudes internally and generate a simple fault detection signal. With 1 V<sub>PP</sub> signals, the analysis of output signals is possible only in external test devices or through computation in the subsequent electronics (analog diagnostics interface).

Absolute encoders operate with serial data transfer. Depending on the interface, additional 1 V<sub>PP</sub> incremental signals can be output. The signals are monitored comprehensively within the encoder. The monitoring result (especially with valuation numbers) can be transferred along with the position value through the serial interface to the subsequent electronics (digital diagnostics interface). The following information is available:

- Error message: Position value not reliable
- Warning: An internal functional limit of the encoder has been reached
- Valuation numbers:
  - Detailed information on the encoder's functional reserve
  - Identical scaling for all HEIDENHAIN encoders
  - Cyclic output is possible

This enables the subsequent electronics to evaluate the current status of the encoder with little effort even in closed-loop mode.

HEIDENHAIN offers the appropriate PWM inspection devices and PWT test devices for encoder analysis. There are two types of diagnostics, depending on how the devices are integrated:

- Encoder diagnostics: The encoder is connected directly to the test or inspection device. This makes a comprehensive analysis of encoder functions possible.
- Diagnostics in the control loop: The PWM phase meter is looped into the closed control loop (e.g. through a suitable testing adapter). This makes a real-time diagnosis of the machine or system possible during operation. The functions depend on the interface.

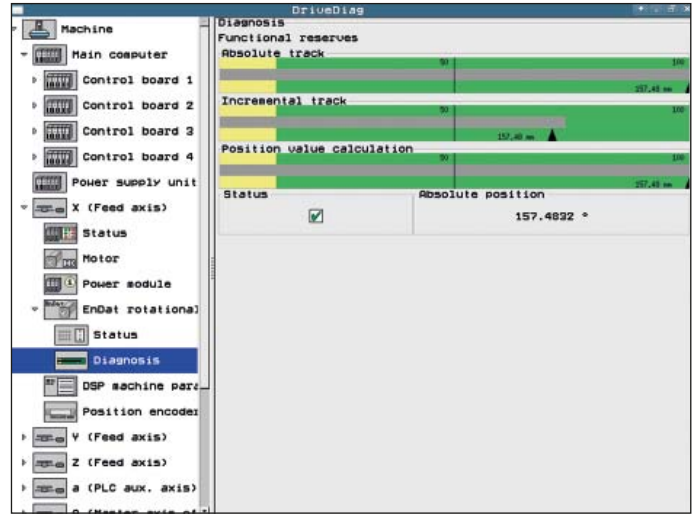

Diagnostics in the control loop on HEIDENHAIN controls with display of the valuation number or the analog encoder signals

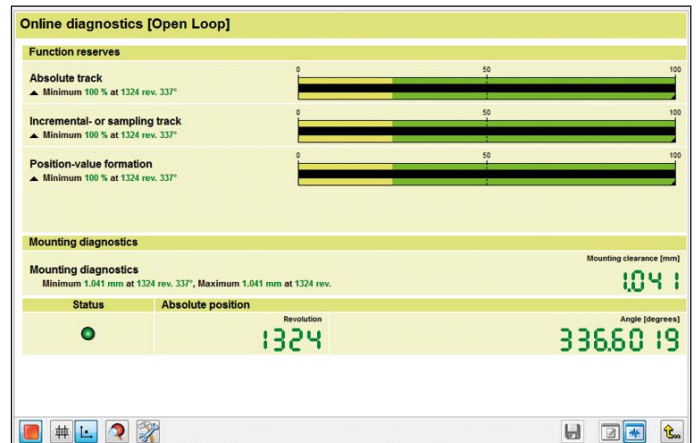

Diagnostics using PWM 20 and ATS software

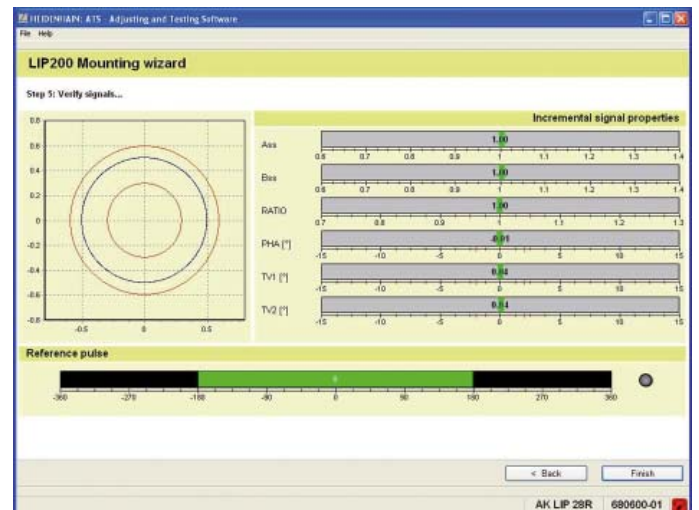

Commissioning using PWM 20 and ATS software



## PWM 20

Together with the ATS adjusting and testing software, the PWM 20 phase angle measuring unit serves for diagnosis and adjustment of HEIDENHAIN encoders.



	PWM 20
<b>Encoder input</b>	<ul style="list-style-type: none"> <li>• EnDat 2.1 or EnDat 2.2 (absolute value with/without incremental signals)</li> <li>• DRIVE-CLiQ</li> <li>• Fanuc Serial Interface</li> <li>• Mitsubishi high speed interface</li> <li>• Yaskawa Serial Interface</li> <li>• SSI</li> <li>• 1 V<sub>PP</sub>/TTL/11 μApp</li> </ul>
<b>Interface</b>	USB 2.0
<b>Voltage supply</b>	AC 100 V to 240 V or DC 24 V
<b>Dimensions</b>	258 mm x 154 mm x 55 mm

	ATS
<b>Languages</b>	Choice between English and German
<b>Functions</b>	<ul style="list-style-type: none"> <li>• Position display</li> <li>• Connection dialog</li> <li>• Diagnostics</li> <li>• Mounting wizard for EBI/ECI/EQI, LIP 200, LIC 4000 and others</li> <li>• Additional functions (if supported by the encoder)</li> <li>• Memory contents</li> </ul>
<b>System requirements and recommendations</b>	PC (dual-core processor, > 2 GHz) RAM > 2 GB Windows operating systems XP, Vista, 7 (32-bit/64-bit), 8 200 MB free space on hard disk

DRIVE-CLiQ is a registered trademark of SIEMENS AG.

The **PWM 9** is a universal measuring device for inspecting and adjusting HEIDENHAIN incremental encoders. Expansion modules are available for checking the various types of encoder signals. The values can be read on an LCD monitor. Soft keys provide ease of operation.



	PWM 9
<b>Inputs</b>	Expansion modules (interface boards) for 11 μApp; 1 V <sub>PP</sub> ; TTL; HTL; EnDat*/SSI*/commutation signals *No display of position values or parameters
<b>Functions</b>	<ul style="list-style-type: none"> <li>• <b>Measures</b> signal amplitudes, current consumption, operating voltage, scanning frequency</li> <li>• <b>Graphic display</b> of incremental signals (amplitudes, phase angle and on-off ratio) and the length and width of the reference signal</li> <li>• <b>Display symbols</b> for the reference mark, fault detection signal, counting direction</li> <li>• <b>Universal counter</b>, interpolation selectable from single to 1024-fold</li> <li>• <b>Adjustment support</b> for exposed linear encoders</li> </ul>
<b>Outputs</b>	<ul style="list-style-type: none"> <li>• Inputs are connected through to the subsequent electronics</li> <li>• BNC sockets for connection to an oscilloscope</li> </ul>
<b>Voltage supply</b>	DC 10 V to 30 V, max. 15 W
<b>Dimensions</b>	150 mm x 205 mm x 96 mm

# Interface electronics

Interface electronics from HEIDENHAIN adapt the encoder signals to the interface of the subsequent electronics. They are used when the subsequent electronics cannot directly process the output signals from HEIDENHAIN encoders, or if additional interpolation of the signals is necessary.

## Input signals of the interface electronics

Interface electronics from HEIDENHAIN can be connected to encoders with sinusoidal signals of 1 V<sub>PP</sub> (voltage signals) or 11 μA<sub>PP</sub> (current signals). Encoders with the serial interfaces EnDat or SSI can also be connected to various interface electronics.

## Output signals of the interface electronics

Interface electronics with the following interfaces to the subsequent electronics are available:

- TTL square-wave pulse trains
- EnDat 2.2
- DRIVE-CLiQ
- Fanuc Serial Interface
- Mitsubishi high speed interface
- Yaskawa Serial Interface
- Profibus

## Interpolation of the sinusoidal input signals

In addition to being converted, the sinusoidal encoder signals are also interpolated in the interface electronics. This permits finer measuring steps and, as a result, higher control quality and better positioning behavior.

## Formation of a position value

Some interface electronics have an integrated counting function. Starting from the last reference point set, an absolute position value is formed when the reference mark is traversed, and is transferred to the subsequent electronics.

## Box design



## Plug design



## Version for integration



## Top-hat rail design



Outputs		Inputs		Design – Protection class	Interpolation <sup>1)</sup> or subdivision	Model	
Interface	Qty.	Interface	Qty.				
□ TTL	1	~ 1 V <sub>PP</sub>	1	Box design – IP65	5/10-fold	<b>IBV 101</b>	
					20/25/50/100-fold	<b>IBV 102</b>	
					Without interpolation	<b>IBV 600</b>	
					25/50/100/200/400-fold	<b>IBV 660B</b>	
				Plug design – IP40	5/10/20/25/50/100-fold	<b>APE 371</b>	
				Version for integration – IP00	5/10-fold	<b>IDP 181</b>	
		20/25/50/100-fold	<b>IDP 182</b>				
		~ 11 μA <sub>PP</sub>	1	Box design – IP65	1	5/10-fold	<b>EXE 101</b>
						20/25/50/100-fold	<b>EXE 102</b>
						Without/5-fold	<b>EXE 602E</b>
25/50/100/200/400-fold	<b>EXE 660B</b>						
Version for integration – IP00	5-fold				<b>IDP 101</b>		
□ TTL/ ~ 1 V <sub>PP</sub> Adjustable	2	~ 1 V <sub>PP</sub>	1	Box design – IP65	2-fold	<b>IBV 6072</b>	
					5/10-fold	<b>IBV 6172</b>	
					5/10-fold and 20/25/50/100-fold	<b>IBV 6272</b>	
EnDat 2.2	1	~ 1 V <sub>PP</sub>	1	Box design – IP65	≤ 16384-fold subdivision	<b>EIB 192</b>	
				Plug design – IP40	≤ 16384-fold subdivision	<b>EIB 392</b>	
			2	Box design – IP65	≤ 16384-fold subdivision	<b>EIB 1512</b>	
DRIVE-CLiQ	1	EnDat 2.2	1	Box design – IP65	–	<b>EIB 2391S</b>	
Fanuc Serial Interface	1	~ 1 V <sub>PP</sub>	1	Box design – IP65	≤ 16384-fold subdivision	<b>EIB 192F</b>	
				Plug design – IP40	≤ 16384-fold subdivision	<b>EIB 392F</b>	
			2	Box design – IP65	≤ 16384-fold subdivision	<b>EIB 1592F</b>	
Mitsubishi high speed interface	1	~ 1 V <sub>PP</sub>	1	Box design – IP65	≤ 16384-fold subdivision	<b>EIB 192M</b>	
				Plug design – IP40	≤ 16384-fold subdivision	<b>EIB 392M</b>	
			2	Box design – IP65	≤ 16384-fold subdivision	<b>EIB 1592M</b>	
Yaskawa Serial Interface	1	EnDat 2.2 <sup>2)</sup>	1	Plug design – IP40	–	<b>EIB 3391Y</b>	
PROFIBUS-DP	1	EnDat 2.1; EnDat 2.2	1	Top-hat rail design	–	<b>PROFIBUS Gateway</b>	

<sup>1)</sup> Switchable

<sup>2)</sup> Only LIC 4100 with 5 nm measuring step, LIC 2100 with 50 nm and 100 nm measuring steps

# HEIDENHAIN

## DR. JOHANNES HEIDENHAIN GmbH

Dr.-Johannes-Heidenhain-Straße 5

83301 Traunreut, Germany

☎ +49 8669 31-0

FAX +49 8669 32-5061

E-mail: info@heidenhain.de

www.heidenhain.de

Vollständige und weitere Adressen siehe [www.heidenhain.de](http://www.heidenhain.de)  
For complete and further addresses see [www.heidenhain.de](http://www.heidenhain.de)

<b>DE</b>	<b>HEIDENHAIN Vertrieb Deutschland</b> 83301 Traunreut, Deutschland ☎ 08669 31-3132 FAX 08669 32-3132 E-Mail: hd@heidenhain.de	<b>ES</b>	<b>FARRESA ELECTRONICA S.A.</b> 08028 Barcelona, Spain www.farresa.es	<b>PL</b>	<b>APS</b> 02-384 Warszawa, Poland www.heidenhain.pl
	<b>HEIDENHAIN Technisches Büro Nord</b> 12681 Berlin, Deutschland ☎ 030 54705-240	<b>FI</b>	<b>HEIDENHAIN Scandinavia AB</b> 01740 Vantaa, Finland www.heidenhain.fi	<b>PT</b>	<b>FARRESA ELECTRÓNICA, LDA.</b> 4470 - 177 Maia, Portugal www.farresa.pt
	<b>HEIDENHAIN Technisches Büro Mitte</b> 07751 Jena, Deutschland ☎ 03641 4728-250	<b>FR</b>	<b>HEIDENHAIN FRANCE sarl</b> 92310 Sèvres, France www.heidenhain.fr	<b>RO</b>	<b>HEIDENHAIN Reprezentantă Romania</b> Braşov, 500407, Romania www.heidenhain.ro
	<b>HEIDENHAIN Technisches Büro West</b> 44379 Dortmund, Deutschland ☎ 0231 618083-0	<b>GB</b>	<b>HEIDENHAIN (G.B.) Limited</b> Burgess Hill RH15 9RD, United Kingdom www.heidenhain.co.uk	<b>RS</b>	Serbia → <b>BG</b>
	<b>HEIDENHAIN Technisches Büro Südwest</b> 70771 Leinfelden-Echterdingen, Deutschland ☎ 0711 993395-0	<b>GR</b>	<b>MB Milionis Vassilis</b> 17341 Athens, Greece www.heidenhain.gr	<b>RU</b>	<b>OOO HEIDENHAIN</b> 115172 Moscow, Russia www.heidenhain.ru
	<b>HEIDENHAIN Technisches Büro Südost</b> 83301 Traunreut, Deutschland ☎ 08669 31-1345	<b>HK</b>	<b>HEIDENHAIN LTD</b> Kowloon, Hong Kong E-mail: sales@heidenhain.com.hk	<b>SE</b>	<b>HEIDENHAIN Scandinavia AB</b> 12739 Skärholmen, Sweden www.heidenhain.se
		<b>HR</b>	Croatia → <b>SL</b>	<b>SG</b>	<b>HEIDENHAIN PACIFIC PTE LTD.</b> Singapore 408593 www.heidenhain.com.sg
<b>AR</b>	<b>NAKASE SRL.</b> B1653AOX Villa Ballester, Argentina www.heidenhain.com.ar	<b>HU</b>	<b>HEIDENHAIN Kereskedelmi Képviselet</b> 1239 Budapest, Hungary www.heidenhain.hu	<b>SK</b>	<b>KOPRETINA TN s.r.o.</b> 91101 Trenčín, Slovakia www.kopretina.sk
<b>AT</b>	<b>HEIDENHAIN Techn. Büro Österreich</b> 83301 Traunreut, Germany www.heidenhain.de	<b>ID</b>	<b>PT Servitama Era Toolsindo</b> Jakarta 13930, Indonesia E-mail: ptset@group.gts.co.id	<b>SL</b>	<b>NAVO d.o.o.</b> 2000 Maribor, Slovenia www.heidenhain.si
<b>AU</b>	<b>FCR Motion Technology Pty. Ltd</b> Laverton North 3026, Australia E-mail: vicsales@fcrmotion.com	<b>IL</b>	<b>NEUMO VARGUS MARKETING LTD.</b> Tel Aviv 61570, Israel E-mail: neumo@neumo-vargus.co.il	<b>TH</b>	<b>HEIDENHAIN (THAILAND) LTD</b> Bangkok 10250, Thailand www.heidenhain.co.th
<b>BE</b>	<b>HEIDENHAIN NV/SA</b> 1760 Roosdaal, Belgium www.heidenhain.be	<b>IN</b>	<b>HEIDENHAIN Optics &amp; Electronics India Private Limited</b> Chetpet, Chennai 600 031, India www.heidenhain.in	<b>TR</b>	<b>T&amp;M Mühendislik San. ve Tic. LTD. ŞTİ.</b> 34775 Y. Dudullu – Ümraniye-Istanbul, Turkey www.heidenhain.com.tr
<b>BG</b>	<b>ESD Bulgaria Ltd.</b> Sofia 1172, Bulgaria www.esd.bg	<b>IT</b>	<b>HEIDENHAIN ITALIANA S.r.l.</b> 20128 Milano, Italy www.heidenhain.it	<b>TW</b>	<b>HEIDENHAIN Co., Ltd.</b> Taichung 40768, Taiwan R.O.C. www.heidenhain.com.tw
<b>BR</b>	<b>DIADUR Indústria e Comércio Ltda.</b> 04763-070 – São Paulo – SP, Brazil www.heidenhain.com.br	<b>JP</b>	<b>HEIDENHAIN K.K.</b> Tokyo 102-0083, Japan www.heidenhain.co.jp	<b>UA</b>	<b>Gertner Service GmbH Büro Kiev</b> 01133 Kiev, Ukraine www.heidenhain.ua
<b>BY</b>	<b>GERTNER Service GmbH</b> 220026 Minsk, Belarus www.heidenhain.by	<b>KR</b>	<b>HEIDENHAIN Korea LTD.</b> Gasan-Dong, Seoul, Korea 153-782 www.heidenhain.co.kr	<b>US</b>	<b>HEIDENHAIN CORPORATION</b> Schaumburg, IL 60173-5337, USA www.heidenhain.com
<b>CA</b>	<b>HEIDENHAIN CORPORATION</b> Mississauga, Ontario L5T2N2, Canada www.heidenhain.com	<b>MX</b>	<b>HEIDENHAIN CORPORATION MEXICO</b> 20290 Aguascalientes, AGS., Mexico E-mail: info@heidenhain.com	<b>VE</b>	<b>Maquinaria Diekmann S.A.</b> Caracas, 1040-A, Venezuela E-mail: purchase@diekmann.com.ve
<b>CH</b>	<b>HEIDENHAIN (SCHWEIZ) AG</b> 8603 Schwerzenbach, Switzerland www.heidenhain.ch	<b>MY</b>	<b>ISOSERVE SDN. BHD.</b> 43200 Balakong, Selangor E-mail: sales@isoserve.com.my	<b>VN</b>	<b>AMS Co. Ltd</b> HCM City, Vietnam E-mail: davidgoh@amsvn.com
<b>CN</b>	<b>DR. JOHANNES HEIDENHAIN (CHINA) Co., Ltd.</b> Beijing 101312, China www.heidenhain.com.cn	<b>NL</b>	<b>HEIDENHAIN NEDERLAND B.V.</b> 6716 BM Ede, Netherlands www.heidenhain.nl	<b>ZA</b>	<b>MAFEMA SALES SERVICES C.C.</b> Midrand 1685, South Africa www.heidenhain.co.za
<b>CZ</b>	<b>HEIDENHAIN s.r.o.</b> 102 00 Praha 10, Czech Republic www.heidenhain.cz	<b>NO</b>	<b>HEIDENHAIN Scandinavia AB</b> 7300 Orkanger, Norway www.heidenhain.no		
<b>DK</b>	<b>TPTEKNIK A/S</b> 2670 Greve, Denmark www.tp-gruppen.dk	<b>PH</b>	<b>Machinebanks Corporation</b> Quezon City, Philippines 1113 E-mail: info@machinebanks.com		

