

# AC motors

Three-phase AC motors

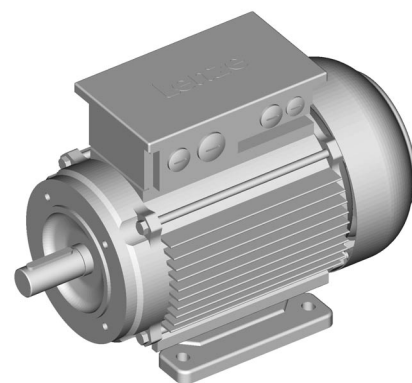

M□□MA; Basic M□ERA...V1  
| 0.12 kW ... 45 kW

Operating Instructions

EN



13496796

**Lenze**



Please read these instructions before you start working!  
Follow the enclosed safety instructions.



**Note!**

For safety-rated built-on accessories, the manufacturer's operating instructions have to be observed!

---

1	About this documentation .....	5
	1.1 Document history .....	5
	1.2 Conventions used .....	6
	1.3 Terminology used .....	6
	1.4 Notes used .....	7
2	Safety instructions .....	8
	2.1 General safety instructions for drive components .....	8
	2.2 Application as directed .....	10
	2.3 Foreseeable misuse .....	11
	2.4 Residual hazards .....	11
	2.5 Disposal .....	12
3	Product description .....	13
	3.1 Identification .....	13
	3.1.1 Motor code .....	14
	3.1.2 Nameplate .....	16
4	Technical data .....	18
	4.1 General data and operating conditions .....	18
5	Mechanical installation .....	19
	5.1 Important notes .....	19
	5.2 Preparation .....	20
	5.3 Installation .....	21
	5.4 Assembly of built-on accessories .....	22
	5.5 Spring-applied brakes .....	22
	5.6 Locking of the manual release .....	24
6	Electrical installation .....	26
	6.1 Important notes .....	26
	6.2 Three-phase AC motor operation on a frequency inverter .....	27
	6.3 EMC-compliant wiring .....	27
	6.3.1 Power connections on the terminal board .....	28
	6.3.2 Brake connection .....	29
	6.3.3 Feedback system .....	30
	6.4 Plug connectors .....	30
	6.4.1 Motor plug connection assignment .....	30
	6.4.2 Power connections .....	31
	6.4.3 Feedback system .....	32
	6.5 Terminal box HAN connectors .....	34

7	Commissioning and operation .....	36
7.1	Important notes .....	36
7.2	Before switching on .....	36
7.3	Functional test .....	37
7.4	During operation .....	38
8	Maintenance/repair .....	39
8.1	Important notes .....	39
8.2	Maintenance intervals .....	39
8.2.1	Motor .....	39
8.2.2	Encoder .....	39
8.2.3	Spring-operated brakes .....	40
8.3	Maintenance operations .....	40
8.3.1	Motor .....	40
8.3.2	Spring-operated brakes .....	41
8.3.3	Checking the component parts .....	42
8.3.4	Checking the rotor thickness .....	43
8.3.5	Checking the air gap .....	43
8.3.6	Release / voltage .....	44
8.3.7	Adjusting the air gap .....	44
8.3.8	Rotor replacement .....	45
8.4	Installation of a spring-applied brake .....	45
8.4.1	Brake characteristics .....	45
8.4.2	Installation of the brake .....	46
8.4.3	Adjusting the air gap .....	47
8.4.4	Assembly of the friction plate, sizes 06 to 16 .....	48
8.4.5	Assembly of the flange .....	48
8.4.6	Assembly of the cover seal .....	49
8.5	Repair .....	49
9	Troubleshooting and fault elimination .....	50
10	Appendix .....	52
10.1	Technical data as specified by ordinances (EU) No. 4/2014 and (EC) No. 640/2009 .....	52

## Contents

- The present documentation serves to safely work on and with the drives. It includes safety instructions which must be observed.
- All persons working on and with the drives must have the documentation available and must observe the information and notes relevant for their work.
- The documentation must always be in a complete and perfectly readable state.

If the information provided in this documentation is not sufficient in your case, please refer to the controller or gearbox documentation.



### Tip!

Information and tools concerning the Lenze products can be found in the download area at [www.lenze.com](http://www.lenze.com)

## Validity

This documentation is valid for three-phase AC motors:

Type	Name
L-force M□□MA Basic M□ERA...V1	Three-phase AC motors (squirrel cage induction motor)

## Target group

This documentation is directed at qualified skilled personnel according to IEC 60364.

Qualified skilled personnel are persons who have the required qualifications to carry out all activities involved in installing, mounting, commissioning, and operating the product.

### 1.1 Document history

Material number	Version			Description
13366623	1.0	12/2010	TD09	First edition of the operating instructions, separated from servo motors
13403644	2.0	03/2012	TD09	Supplement with UL warning Table "Screw-in depth B14 flange" added Nameplates updated
13493764	3.0	06/2015	TD09	Complete revision
13496796	4.0	08/2015	TD09	Supplemented by chapter: Technical data according to EU and EG regulation





# 1 About this documentation

## Conventions used

---

### 1.2 Conventions used

This documentation uses the following conventions to distinguish different types of information:

Type of information	Writing	Example/notes
Spelling of numbers		
Decimal	Normal spelling	Example: 1234
Decimal separator	Point	The decimal point is always used. For example: 1234.56
Icons		
Page reference		Reference to another page with additional information For instance:  16 = see page 16
Documentation reference		Reference to another documentation with additional information Example:  EDKxxx = see EDKxxx documentation
Wildcard		Wildcard for options, selection data

### 1.3 Terminology used

Term	Describes the following
Motor	Three-phase AC motor (squirrel cage induction motor) in versions according to product key,  14 .
Controller	Any servo inverter Any frequency inverter
Drive system	Drive systems including three-phase AC motors and other Lenze drive components



## 1.4 Notes used

The following pictographs and signal words are used in this documentation to indicate dangers and important information:



### Safety instructions

Layout of the safety instructions:

 **Danger!**  
 (characterises the type and severity of danger)  
**Note**  
 (describes the danger and gives information about how to prevent dangerous situations)

Pictograph and signal word	Meaning
 <b>Danger!</b>	<b>Danger of personal injury through dangerous electrical voltage</b> Reference to an imminent danger that may result in death or serious personal injury if the corresponding measures are not taken.
 <b>Danger!</b>	<b>Danger of personal injury through a general source of danger</b> Reference to an imminent danger that may result in death or serious personal injury if the corresponding measures are not taken.
 <b>Stop!</b>	<b>Danger of property damage</b> Reference to a possible danger that may result in property damage if the corresponding measures are not taken.

### Application notes

Pictograph and signal word	Meaning
 <b>Note!</b>	Important note to ensure trouble-free operation
 <b>Tip!</b>	Useful tip for easy handling
	Reference to another document

 **Warnings!**  
**Important installation instructions for flange-mounted motors**  
 The operating instructions indicates that the motor housing has threaded holes or through holes.

- These holes may not be used to install feet.
- Motor mounting is only allowed as fixed installation without feet.

## 2 Safety instructions

### General safety instructions for drive components

---

#### 2.1 General safety instructions for drive components

At the time of dispatch, the drive components are in line with the latest state of the art and can be regarded as operationally safe.

#### Scope

The following general safety instructions apply to all Lenze drive and automation components.

**The product-specific safety and application notes given in this documentation must be observed!**

#### General hazards



#### **Danger!**

Disregarding the following basic safety measures may lead to severe personal injury and damage to material assets!

- Lenze drive and automation components ...
  - ... must only be used for the intended purpose.
  - ... must never be operated if damaged.
  - ... must never be subjected to technical modifications.
  - ... must never be operated unless completely assembled.
  - ... must never be operated without the covers/guards.
  - ... can - depending on their degree of protection - have live, movable or rotating parts during or after operation. Surfaces can be hot.
- All specifications of the corresponding enclosed documentation must be observed.

This is vital for safe and trouble-free operation and for achieving the specified product features.
- Only qualified skilled personnel are permitted to work with or on Lenze drive and automation components.

According to IEC 60364 or CENELEC HD 384, these are persons ...

  - ... who are familiar with the installation, assembly, commissioning and operation of the product,
  - ... possess the appropriate qualifications for their work,
  - ... and are acquainted with and can apply all the accident prevent regulations, directives and laws applicable at the place of use.



### Storage

- In a dry, low-vibration environment without aggressive atmosphere;
- In the original packaging;
- Protect against dust and impacts;
- Observe climatic conditions according to the technical data.

### Storage conditions

- Up to one year:
  - Shafts and uncoated surfaces are delivered in a protected against rust status. Aftertreatment is required where the corrosion protection has been damaged.
- More than one year, up to two years:
  - Apply a long-term corrosion preventive (e.g. Anticorit BW 366 from the Fuchs company) to the shafts and uncoated surfaces before storing the motor away.

### Transport

#### Before transport

- check that all component parts are safely mounted;
- check that all component parts with a loose fastening are secured or removed;
- tighten all transport aids (eye bolts or support plates).

Use an appropriate means of transport and lifting equipment! (📖 19)



#### Stop!

##### Danger by toppling or falling loads!

##### Observe payloads!

- The payload of the hoists and load handling devices must at least correspond to the weight of the load, for weights see the 📖 catalogue.
- Secure the load so that it will not topple or fall down.
- Walk under suspended loads prohibited!



#### Danger!

Completely screw in transport aids (such as eye bolts or bearing plates), they must be flat and applied over their entire surface!

If possible, the transport aids (such as eye bolts or bearing plates) must be stressed vertically in the direction of the screw axis! Angular tension or tension to the sides reduces the payload! Observe the information provided in DIN 580!

Use additional appropriate lifting aids, if required, to achieve a direction of loading which is as vertical as possible (highest payload). Secure lifting aids against shifting!

## 2 Safety instructions

Application as directed

---

### Corrosion protection

Lenze offers paints with different resistance characteristics for drive systems. Since the resistance may be reduced when the paint coat is damaged, defects in paint work (e.g. through transport or assembly) must be removed professionally to reach the required corrosion resistance.

### Mechanical installation

- Provide for careful handling and avoid mechanical overload. During handling neither bend components, nor change the insulation distances.

### Electrical installation

- Carry out the electrical installation according to the relevant regulations (e. g. cable cross-sections, fusing, connection to the PE conductor). Additional notes are included in the documentation.
- Only plug in or remove pluggable terminals in the deenergised state!

### Commissioning

- If required, you have to equip the system with additional monitoring and protective devices in accordance with the respective valid safety regulations (e. g. law on technical equipment, regulations for the prevention of accidents).
- Before commissioning remove transport locking devices and keep them for later transports.

## 2.2 Application as directed

Low-voltage machines are not household appliances but are intended as components that are only applied for re-use for industrial or professional purposes in terms of IEC/EN 61000-3-2. They comply with the requirements of the Low-Voltage Directive and the harmonised standards of the IEC/EN 60034 series.

Low-voltage machines must only be operated under the operating conditions and power limits specified in this documentation.

The integrated brakes must not be used as safety brakes. It cannot be ruled out that interference factors which cannot be influenced cause a brake torque reduction.

Lowvoltage machines with IP23 protection or less are only intended for outdoor use when applying special protective features.

Products included in the scope of application of the EU regulations (EG) 640/2009 and (EU) 4/2014 (and hence ErP Directive 2009/125/EG) and which did not comply with minimum efficiency requirements when first put into circulation, are not CE compliant and will not receive CE marking. The product is for exclusive use outside the European Economic Area (EEA) only.

Motors of efficiency class IE2 with a rated power of 7.5 kW ... 375 kW which are included in the scope of application of the EU regulations (EG) 640/2009 and (EU) 4/2014 and which were put into circulation in the European Economic Area (EEA) after 31 December 2014 may be exclusively used there on a frequency inverter for speed control only. These motors receive the following additional marking.

<b>IE2</b>	EU REGULATION 640/2009 USE WITH VARIABLE SPEED DRIVE ONLY!
------------	--

**Any other use shall be deemed inappropriate!**

### 2.3 Foreseeable misuse

- Do not operate the motors
  - ... in explosion-protected areas
  - ... in aggressive environments (acid, gas, vapour, dust, oil)
  - ... in water
  - ... in radiation environments



#### Note!

Increased surface and corrosion protection can be achieved by using adapted coating systems.

### 2.4 Residual hazards

#### Protection of persons

- The motor surfaces can become very hot. Danger of burns when touching!
  - Provide protection against accidental contact, if necessary.
- Danger of unintentional starting or electrical shocks
  - Connections must only be made when the equipment is deenergised and the motor is at standstill.
  - Installed brakes are no fail-safe brakes.

## 2 Safety instructions

### Disposal

---

#### Motor protection

- Installed thermal detectors are **no full protection** for the machine.
  - Installed overload protection does not prevent an overload under any conditions.
- Installed brakes are **no fail-safe brakes**.
  - The torque may be reduced by disruptive factors that cannot be influenced such as contamination by oil.
- Fuses are no motor protection.
  - Use current-dependent motor protection switches at average operating frequency.
  - Use installed thermal detectors at high operating frequency.
- Too high torques cause a fraction of the motor shaft.
  - The maximum torques according to catalogue must not be exceeded.
- Lateral forces from the motor shaft may occur.
  - Align shafts of motor and driving machine exactly to each other.
- If deviations from normal operation occur, e.g. increased temperature, noise, vibration, determine the cause and, if necessary, contact the manufacturer. If in doubt, switch off the motor.

#### Fire protection

- Fire hazard
  - Prevent contact with flammable substances.

### 2.5 Disposal

Sort individual parts according to their properties. Dispose of them as specified by the current national regulations.

3.1 Identification

Three-phase AC motors ...

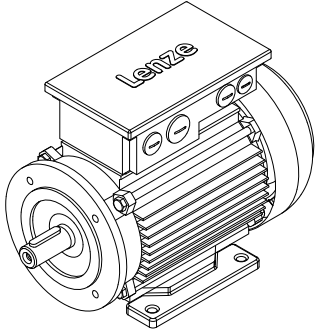
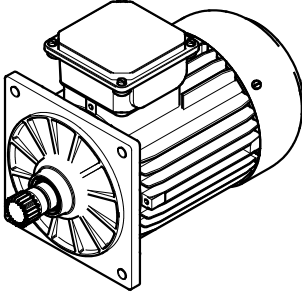
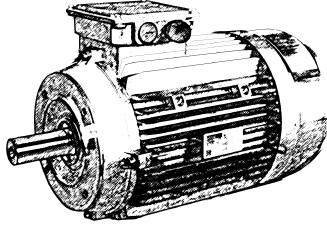
<p><b>M□□MA</b> Motor with standard output flange</p>	<p>Motor with square flange for direct gearbox attachment</p>
 <p style="text-align: right; font-size: small;">MT-MDEMA-005.iso/dms</p>	
<p><b>M□ERA...V1</b> Basic standard motor</p>	
 <p style="text-align: right; font-size: small;">MT-MXERA-001.bmp/dms</p>	

# 3 Product description

Identification  
Motor code

## 3.1.1 Motor code

### Three-phase AC motors M□□MA

Example		M	D	E	MA	XX	063	-	4	2	C1	C
Meaning	Variant	Motor code										
Product family		M										
Efficiency class	IE1		D									
	IE2		H									
Cooling	Natural ventilation			S								
	Integral fan			E								
	Blower			F								
Internal key					MA							
Built-on accessories	Without built-on accessories					XX						
	Brake					BR						
	Brake + resolver					BS						
	Brake + incremental encoder					BI						
	Brake + sin/cos absolute value encoder					BA						
	Brake + 2nd shaft end					BZ						
	Brake + handwheel					BH						
	Brake + grey iron fan					BL						
	Resolver					RS						
	Incremental encoder					IG						
	Sin/cos absolute value encoder					AG						
	2nd shaft end					ZE						
	Handwheel					HA						
	Grey iron fan					LL						
	Grey iron fan + 2nd shaft end					LZ						
Grey iron fan + handwheel					LH							
Size							063					
							071					
							080					
							090					
							100					
							112					
							132					
							160					
							180					
							200					
						225						
Overall length									0			
									1			
									2			
									3			
									4			
Number of pole pairs	2-pole motors									1		
	4-pole motors									2		
	6-pole motors									3		
Design type	Internal key										C1	
Approval	CE											C
	cURus											V
	CCC											3

Encoder code

Example		SFC	1024	-	8V	-	K	2	
Meaning	Type	Encoder code							
Product line	Resolver	RS							
	Resolver for safety function	RV							
	Incremental encoder	IG							
	Incremental encoder with commutation signal	IK							
	Singleturn absolute value encoder	SFC							
	Multiturn absolute value encoder	AM							
Number	2-pole resolver for servo motors		0						
	2-pole resolver for three-phase AC motors		1						
	Number of pole pairs for resolvers		2, 3, 4,...						
	Number of steps / increments per revolution		32, 128, 512, 1024, 2048, ...						
Voltage	Medium supply voltage			-	5V, 8V, 15V, 24V, ...				
Interface or signal level	Standard								
	TTL						T		
	HTL (for incremental encoders)						H		
	Hiperface (for absolute value encoders)						H		
	EnDat						E		
	sin/cos 1 V <sub>SS</sub>						S		
	For safety function								
	TTL							U	
	HTL (for incremental encoders)							K	
	Hiperface (for absolute value encoders)							K	
	EnDat							F	
	sin/cos 1 V <sub>SS</sub>							V	
	Safety integration level (SIL)								1
									2
								3	
								4	



**Note!**

If feedback systems for safety functions are used, the manufacturer's documentation must be observed!





Pos.	Contents
1	Manufacturer / production location
2	Type of motor / standard
3	Gearbox type
4	Motor type
5	Technical data
5.1	Ratio
5.2	Rated torque
5.3	Rated speed
5.4	Rated frequency
5.10	Number of poles
6	Mounting position / position of the system blocks
7	Lubricant details
7.1	Lubricant amount
7.2	Lubricant type
8	Brake data
8.1	Type
8.2	AC/DC brake voltage
8.3	Braking torque, electrical power input
9	For feedback / pulse encoder or resolver data see encoder code  15
10	Production data
10.1	Order number
10.2	Material number
10.3	Serial number
11	Bar code
12	Motor number
13	Information with regard to the operating mode
14	Additional motor specifications
14.1	Temperature class
14.2	Enclosure
14.3	Motor protection
15	Applicable conformities, approvals and certificates
16	Rated data for various frequencies
16.1	Hz = frequency
16.2	kW = motor power
16.3	rpm = motor speed
16.4	V = motor voltage
16.5	A = motor current
16.6	$\cos \varphi$ = motor power factor
16.7	$\eta$ = motor efficiency: at a rated power of 100%
16.8	$\eta$ = motor efficiency: at a rated power of 75%
16.9	$\eta$ = motor efficiency: at a rated power of 50%
17	Application factor (specified if <1.0) / load capacity
18	Year of manufacture / week of manufacture
19	UL file number
20	Customer data
20.1	Additional customer data
20.2	Customer order number
21	UL category (e.g. inverter duty motor)
22	C86 = motor code for controller parameterisation (code 0086)
23	Efficiency class
24	Partial load efficiencies for 50Hz operation at a rated power of 50% and 75%
26	CC number Department of Energy (optional)
27	Permissible ambient temperature (e.g. $T_a \leq 40^\circ\text{C}$ )
29	Standstill current (ampere locked rotor ALR)
31	Plug design (number of poles)

# 4 Technical data

## General data and operating conditions

### 4.1 General data and operating conditions

#### General data

Conformity and approval			
Conformity			
CE	2006/42/EC	Machinery Directive	
	2014/35/EU	Low-Voltage Directive	
	2009/125/EC	ErP Directive	
EAC	TP TC 004/2011 (TR CU 004/2011)	On safety of low voltage equipment	Eurasian Conformity TR CU: Technical Regulation of Customs Union
	TP TC 020/2011 (TR CU 020/2011)	Electromagnetic compatibility of technical means	Eurasian Conformity TR CU: Technical Regulation of Customs Union

The applicable approvals for the product you have ordered are specified on the nameplate.

Protection of persons and devices		
Enclosure		See nameplate Degrees of protection only apply to horizontal installation All unused connectors must be closed with protection covers or blanking plugs.
Temperature class	F (155 °C) IEC/EN 60034-1	Exceedance of the temperature limit weakens or destroys the insulation
Permissible voltage		As specified by limiting curve A of the pulse voltage from IEC / TS 60034-25:2007 (corresponds to IVIC C/B/B@500V)

EMC		
Noise emission	IEC/EN 61800-3	Depending on the controller, see documentation for the controller.
Noise immunity		

#### Operating conditions

Ambient conditions			
Climatic			
Transport	IEC/EN 60721-3-2	2K3 (-20 °C ... +70 °C)	
Storage	IEC/EN 60721-3-1	1K3 (-20 °C ... +60 °C)	< 3 months
		1K3 (-20 °C ... +40 °C)	> 3 months
Operation	IEC/EN 60721-3-3	3K3 (-20 °C ... +40 °C)	Without brake
		3K3 (-10 °C ... +40 °C)	With brake
		3K3 (-15 °C ... +40 °C)	With power reduction
		> +40 °C	With power reduction see, catalogue
Site altitude		< 1000 m amsl - without power reduction > 1000 m amsl < 4000m amsl with power reduction, see catalogue	
Humidity		Average relative humidity 85 %, without condensation	
Electrical			
Motor connection dependent on the controller (☐ 27)			
Length of motor cable		Ⓢ inverter instructions	
Length of cable for speed feedback			
Mechanical			
	IEC/EN60721-3-3	3M6	

### 5.1 Important notes



#### Danger!

Some of the motors mounted to the gearboxes are equipped with transport aids. They are **only** intended for the mounting/dismounting of the motor to the gearbox and must **not** be used for the entire geared motor!

- Only move the drive with means of transport or hoists that have sufficient load-bearing capacity.
- Ensure safe fixing.
- Avoid shocks!



#### Screw-on dimensions B14 flange

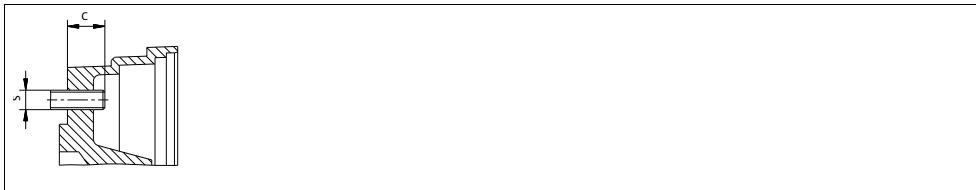

#### Stop!

Observe the maximally permissible screw-in depth for B14 flange!

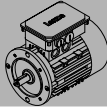

		c max.	s
		[mm]	[mm]
MDERA□□056 V1	FT65	11	M5
MDERA□□063 V1	FT75	14	M5
MDERA□□071 V1	FT85	14	M6
MDERA□□080 V1	FT100	16	M6
MDERA□□090 V1	FT115	14	M8
MDERA□□100 V1	FT130	19	M8
MDERA□□112 V1	FT130	21	M8
MDERA□□132 V1	FT165	22	M10
<hr/>			
M□□MA□N063	FT75	10	M5
M□□MA□N071	FT85	10	M6
M□□MA□N080	FT100	12	M6
M□□MA□N080	FT130	16	M8
M□□MA□N090	FT115	14	M8
M□□MA□N090	FT130	16	M8
M□□MA□N100	FT130	14	M8
M□□MA□N112	FT130	16	M8
<hr/>			
MHERA□□080□	FT100	15	M6
MHERA□□090□	FT115	16	M8
MHERA□□100□	FT130	18	M8
MHERA□□112□	FT130	19	M8
MHERA□□132□	FT165	23	M10

# 5 Mechanical installation

## Preparation

### 5.2 Preparation

Remove the corrosion protection from the shaft ends and flanges. If necessary, remove dirt using standard cleaning solvents.



#### Stop!

Bearings or seals must not come into contact with the solvent - material damages.

After a long storage period (> 1 year) you have to check whether moisture has entered the motor. For this purpose, measure the insulation resistance (measuring voltage 500 V<sub>DC</sub>). In case of values  $\leq 1\text{k}\Omega$  per volt of rated voltage, dry the winding.



#### Stop!

During transport and storage, condensation drain holes (see Fig. 1) are closed with plugs for pollution prevention reasons. Remove the plugs before commissioning!

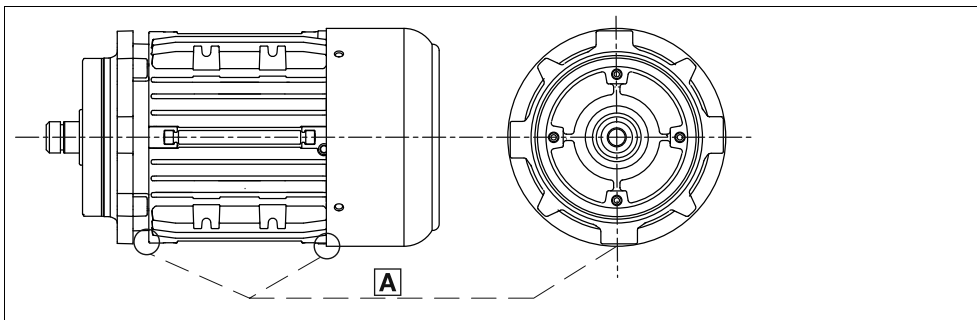

Fig. 1 Motor with condensation drain holes  
A Condensation drain holes

Depending on the mounting position, the condensation drain holes are always at the bottom of the motor!

- For condensate drainage
  - the motor must be deenergised;
  - the plugs (screws) must be removed.



#### Stop!

To restore the enclosure, re-insert the plugs (screws) after condensate drainage. If the condensation drain holes are not sealed again, the IP enclosure of the motor will be reduced. For horizontal motor shafts to IP23 and for vertical motor shafts to IP20.

### 5.3 Installation

- The mounting surface must be dimensioned for the design, the weight, and the torque of the motor.
- The foot and flange faces must rest flat on the mounting surface.
  - An insufficient alignment of the motor shortens the service life of the roller bearings and the transmission elements.

Blows to shafts can cause damage to the bearings.

- Do not exceed the permissible range of ambient operating temperature (📖 18).
- Securely fasten the motor.
- Ensure unobstructed ventilation. The exhaust air, also that of adjacent aggregates, must not be inlet again immediately.
- During operation, surface temperatures of up to 140 °C are possible! Protect against contact!



#### Note!

From the air inlet to other component parts, a minimum distance of 10% of the outer diameter of the fan cover must be complied with!

Ensure an even surface, solid foot or flange mounting and exact alignment if a direct clutch is connected. Avoid resonances with the rotational frequency and double supply frequency which may be caused during assembly.

Only mount or remove transmission elements using appropriate means. In order to facilitate handling, heat them beforehand. Cover belt pulleys and clutches with a touch guard.



#### Stop!

Ensure a correct belt tension!

The machines are halfkey balanced. The clutch must be halfkey balanced, too. The visible jutting out part of the key must be removed.

Designs with shaft end at the bottom must be protected with a cover at the N-end, preventing the ingress of foreign particles into the fan.

# 5 Mechanical installation

## Assembly of built-on accessories

---

### 5.4 Assembly of built-on accessories

Follow these instructions carefully. Please note that the warranty and product liability will become void in the event of impermissible alterations or modifications to the motors.

- Mount the transmission elements:
  - Shocks and impacts must be avoided! They could destroy the motor.
  - For mounting always use the centre bore in the motor shaft as specified by DIN 332-DR-M...
  - Tolerances of the shaft ends:
    - ≤ Ø 50 mm: ISO k6, > Ø 50 mm: ISO m6.
- Only use an extractor for the disassembly.
- When using belts for torque/power transmission:
  - Tension the belts in a controlled manner.
  - Provide protection against accidental contact! During operation, surface temperatures of up to 140°C are possible.

### 5.5 Spring-applied brakes

#### Important notes

As an option, the motors can be fitted with a brake. The installation of brakes (in or on the motor) increases the length of the motor.



#### Note!

The brakes used are not fail-safe because interference factors which cannot be influenced (e.g. oil ingress) may lead to a reduction in torque.

The brakes are used as holding brakes and serve to hold the axes at standstill or in the deenergised state.

Emergency stops at higher speeds are possible but high switching energy increases wear on the friction surfaces and the hub, (▢ 41).

The spring-applied brakes work on the basis of the closed-circuit principle, i.e. the brake is closed in the deenergised state. The brakes for DC supply can be fed with a bridge-rectified DC voltage (bridge rectifier) or with a smoothed DC voltage. The permissible voltage tolerance is ±10 %.

If long motor supply cables are used, pay attention to the ohmic voltage drop along the cable and compensate for it with a higher voltage at the input end of the cable.

The following applies to Lenze system cables:

$U^* = U_B + \left[ \frac{0.08 \Omega}{m} \cdot L \cdot I_B \right]$	$U^*$ [V]	Resulting supply voltage
	$U_B$ [V]	Rated voltage of the brake
	$L$ [m]	Cable length
	$I_B$ [A]	Rated current of the brake



### Stop!

If no suitable voltage (incorrect value, incorrect polarity) is applied to the brake, the brake will be applied and can be overheated and destroyed by the motor continuing to rotate.

The shortest operating times of the brakes are achieved by DC switching of the voltage and an external suppressor circuit (varistor or spark suppressor). Without suppressor circuit, the operating times may increase. A varistor/spark suppressor limits the breaking voltage peaks. It must be ensured that the power limit of the suppressor circuit is not exceeded. This limit depends on the brake current, brake voltage, disengagement time and the switching operations per time unit.

Furthermore the suppressor circuit is necessary for interference suppression and for increasing the service life of the relay contacts (external, not integrated into the motor).

For permissible operating speeds and characteristics, please see the motor catalogue applicable in each case. Emergency stops at higher speeds are possible, but high switching energy increases wear on the friction surfaces and the hub.



### Stop!

The friction surfaces must always be free from oil and grease because even small amounts of grease or oil will considerably reduce the braking torque.

The formula below provides a simplified way to calculate friction energy per switching cycle which must not exceed the limit value for emergency stops that depends on the operating frequency (see motor catalogue; Lenze drive solutions: formulas, dimensioning, and tables).

$Q = \frac{1}{2} \cdot J_{tot} \cdot \Delta\omega^2 \cdot \frac{M_K}{M_K - M_L}$	$Q$ [J]	Friction energy
	$J_{tot}$ [kgm <sup>2</sup> ]	Total mass inertia (motor + load)
	$\Delta\omega$ [1/s]	Angular velocity $\omega=2\pi \cdot n/60$ , $n$ = speed [rpm]
	$M_K$ [Nm]	Characteristic torque
	$M_L$ [Nm]	Load torque

Depending on the operating conditions and possible heat dissipation, surface temperatures can be up to 130 °C.



More detailed information on the used brakes is provided in the corresponding catalogues.

# 5 Mechanical installation

Spring-applied brakes  
Locking of the manual release

## 5.6 Locking of the manual release

### Scope of supply

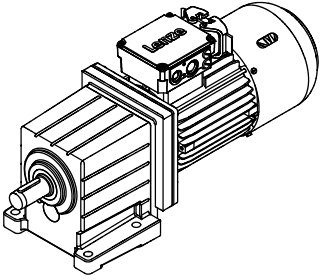
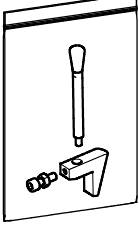
Geared motor	Shipping bag
 <p>GT-GNG-GST-010.iso/dms</p>	 <p>GT-GXX-012.iso/dms GT-GXX-013.iso/dms</p> <ul style="list-style-type: none"><li>• 1 Manual release lever with knob</li><li>• 1 Terminal block</li><li>• 1 Cheese head screw with nut</li></ul>

### Mounting

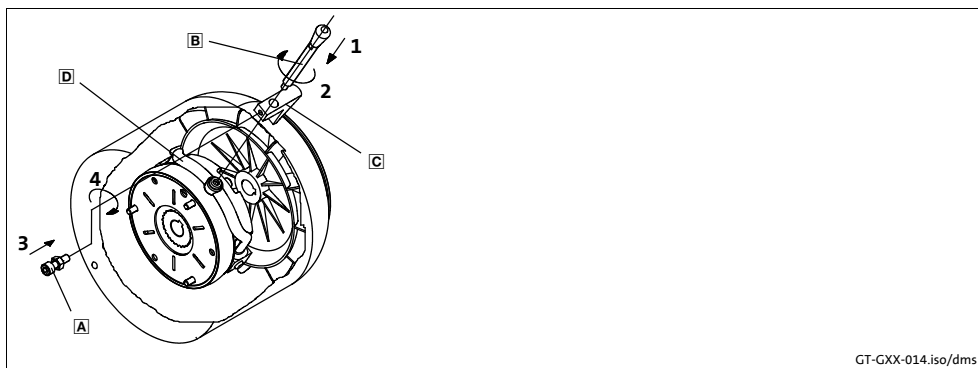

- |   |   |
|---|---|
| <b>A</b> Cheese head screw with nut     | <b>C</b> Terminal block                 |
| <b>B</b> Manual release lever with knob | <b>D</b> Manual release shackle (brake) |

### Handling



#### Stop!

- Lock the manual release only for service work!
- The manual release must not be locked during operation, otherwise the brake could be damaged!
- Always secure the terminal block against loosening in every position with cheese head screw and nut!



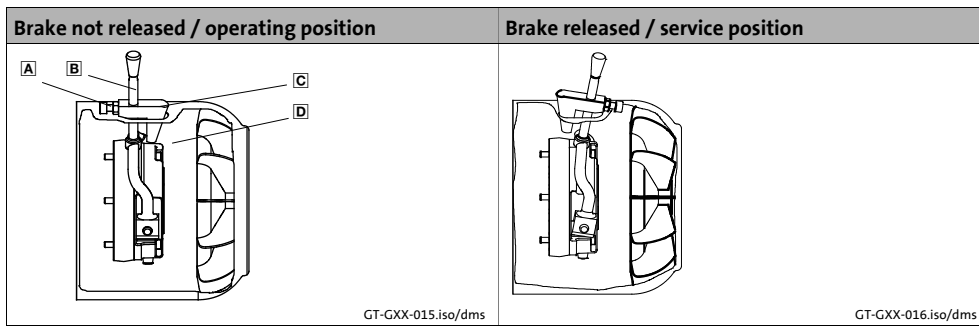

- A** Cheese head screw with nut
- B** Manual release lever with knob

- C** Terminal block
- D** Fan cover

# 6 Electrical installation

## Important notes

---

### 6.1 Important notes



#### Danger!

Hazardous voltage on the power connections even when disconnected from mains: residual voltage >60 V!

Before working on the power connections, always disconnect the drive component from the mains and wait until the motor is at standstill. Verify safe isolation from supply!



#### Stop!

Electrical connections must be carried out in accordance with the national and regional regulations!

- Observe tolerances according to IEC/EN 60034-1:
  - Voltage  $\pm 10\%$
  - Frequency  $\pm 2\%$
  - Wave form, symmetry (increases heating and affects electromagnetic compatibility)
- Observe notes on wiring, information on the nameplate, and the connection scheme in the terminal box.
- The terminal box has to be free of foreign bodies, dirt, and humidity.
- All unused cable entries and the box itself must be sealed against dust and water.
- The connection must ensure a continuous and safe electrical supply, i.e.
  - no loose wire ends,
  - use assigned cable end fittings,
  - ensure good electrical conductivity of the contact (remove residual lacquer) if an (additional) PE connection on the motor housing is used),
  - establish a safe PE conductor connection,
  - tighten the plugin connector to the limit stop.
  - All connections at the terminal board are tightened.
- The smallest air gaps between uncoated, live parts and against earth must not fall below the following values.

Motor diameter	Minimum requirements for basic insulation according to IEC/EN 60664-1 (CE)	Higher requirements for UL design
< 178 mm	3.87 mm	6.4 mm
> 178 mm		9.5 mm

## 6.2 Three-phase AC motor operation on a frequency inverter

The three-phase AC motors described in these instructions are optimised and qualified for the use on Lenze frequency inverters and **can** be combined without restrictions.

If another inverter is used for operation, the voltage peaks ( $U_{pk}$ ) shown in the diagram must not be exceeded with the given rise time ( $t_r$ ).

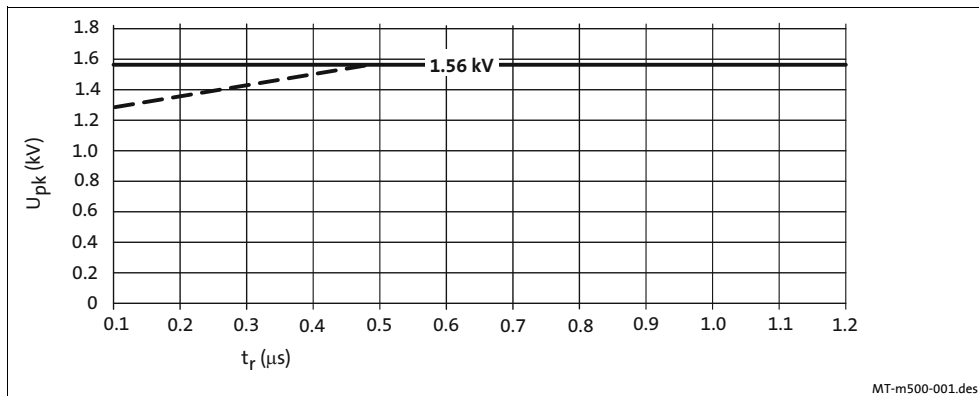

Fig. 2 Permissible voltage peaks for operation on the frequency inverter  
 - - - - IEC/TS 60034-25:2007 (complies with IVIC C/B/B @500 V)  
 ————— Lenze Standard A+

### Possible countermeasures

Appropriate countermeasures must be taken if exceedance of the permissible voltage peaks cannot be ruled out:

- Reduce the DC-bus voltage (brake chopper threshold voltage);
- Use filters, chokes;
- Use of special motor cables.

## 6.3 EMC-compliant wiring

The EMC-compliant wiring of the motors is described in detail in the Operating Instructions for the Lenze controllers.

- Use of metal EMC cable glands with shield connection.
- Connect the shielding to the motor and to the device.

# 6 Electrical installation

## EMC-compliant wiring

### Tightening torques

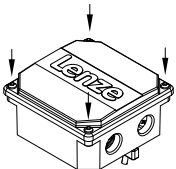
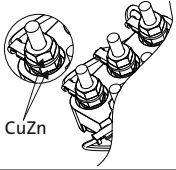
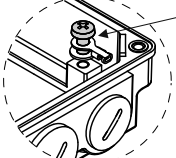
[Nm] +/- 10%	M4	M5	M6	M8
	2.2	3.5	4.5	-----
	1.2	2.0	3.0	6.0
	2.2	3.5	-----	-----

### 6.3.1 Power connections on the terminal board

#### Motor

#### Power connections on the terminal board

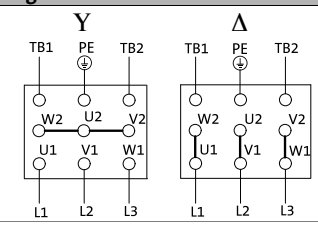
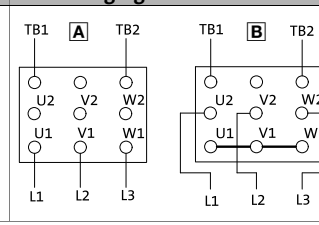
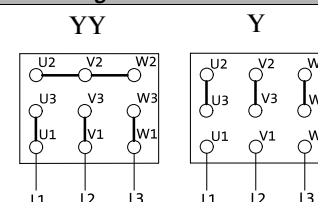
Single-rotation motors	Pole-changing motors														
															
<small>MT_MXXXX_001.iso/dms</small>															
Dual-voltage motors	Legend														
	<table border="1"> <tr> <td>L1/L2/L3</td> <td>Power connection</td> </tr> <tr> <td>TB1/TB2</td> <td>Thermal contact (TKO)</td> </tr> <tr> <td><b>A</b></td> <td>Low speed</td> </tr> <tr> <td><b>B</b></td> <td>High speed</td> </tr> <tr> <td>YY</td> <td>Low voltage</td> </tr> <tr> <td>Y</td> <td>High voltage</td> </tr> <tr> <td>⊕</td> <td>PE connection (optional)</td> </tr> </table>	L1/L2/L3	Power connection	TB1/TB2	Thermal contact (TKO)	<b>A</b>	Low speed	<b>B</b>	High speed	YY	Low voltage	Y	High voltage	⊕	PE connection (optional)
L1/L2/L3	Power connection														
TB1/TB2	Thermal contact (TKO)														
<b>A</b>	Low speed														
<b>B</b>	High speed														
YY	Low voltage														
Y	High voltage														
⊕	PE connection (optional)														

### Temperature monitoring

Terminal strip / terminal board		
Contact	Meaning	Note
TB1	Thermal contact - TCO	Max. 250 V~ Max. 1.6 A ~
TB2		
TP1	PTC thermistor	
TP2		
R1	Thermal sensor +KTY	Observe polarity
R2	Thermal sensor -KTY	

Terminal board or terminal possible for all thermal sensors.

## Blowers via blower terminal box / motor terminal box

### Blower 3~

Terminal board		
Contact	Meaning	Note
U1	Connection to L1 - mains	Observe direction of rotation! In case of wrong direction of rotation, L1 - L2 must be interchanged
V1	Connection to L2 mains	
W1	Connection to L3 mains	

### Separate fan 1~

Terminal board		
Contact	Meaning	Note
U1		Connection to L1 mains
V1 / U2		Connection to N - mains

## 6.3.2 Brake connection

Contact	Meaning	Additional specifications
~		Connection to L1 - mains
~		Connection to N - mains
+		Brake connection
-		Brake connection
		Switching contact, DC switching
BD1	Brake, DC operated	DC connection
BD2	Brake microswitch, release control	Two-way switch
MS2		NC contact
MS4		NO contact
MS1	Brake microswitch, wear control	Two-way switch
MS2		NC contact
MS4		NO contact
MS1	Brake microswitch, manual release	Two-way switch
MS2		NC contact
MS4		NO contact

# 6 Electrical installation

Plug connectors  
Feedback system

## 6.3.3 Feedback system

Resolver		
Contact	Name	Meaning
B1	+ Ref	Transformer windings (reference windings)
B2	- Ref	
B3	Not assigned	
B4	+COS	Stator winding cosine
B5	-COS	
B6	+SIN	Stator winding sine
B7	-SIN	
B8	Not assigned	

Incremental encoder / sin/cos absolute value encoder with Hiperface		
Contact	Name	Meaning
B1	+ U <sub>B</sub>	Supply + Mass
B2	GND	
B3	A / + COS	Track A / process data channel Track A inverse / process data channel
B4	$\bar{A}$ / Ref cos	
B5	B / - SIN	Track B / process data channel Track B inverse / process data channel
B6	$\bar{B}$ / Ref sin	
B7	Z / data +	Zero track / parameter channel + RS485 Zero track inverse / parameter channel - RS485
B8	Z / data -	
B10 <sup>1)</sup>	Shield - housing	Shield - incremental encoder

1) The terminal is not assigned if insulation at N-end shield of the motor has been selected!

## 6.4 Plug connectors



### Stop!

- Tighten the coupling ring of the connector.
- If plugs **without** SpeedTec bayonet nut connectors are used, the connector boxes for the power / encoder / fan connections must be secured by O-rings if loadings by vibration occur:
  - M17 connector box with O-ring 15 x 1.3 mm
  - M23 connector box with O-ring 18 x 1.5 mm

Plug-in connectors (plug/connector box) with SpeedTec bayonet nut connectors are vibration-proof.

- If SpeedTec bayonet nut connectors are used, O-rings must be removed (if any)!
- Never disconnect plugs when voltage is being applied! Otherwise, the plugs could be destroyed! Inhibit the controller before disconnecting the plugs!

### 6.4.1 Motor plug connection assignment



### Note!

When making your selection, the motor data and permissible currents of the cables according to the system cable system manual must be observed.

## 6.4.2 Power connections

### Power / brake / thermal sensor

#### ICN, 6-pole and 8-pole

6-pole (external view of poles)			
Contact	Name	Meaning	M23
1	BD1 / BA1	Brake + / ~	
2	BD2 / BA2	Brake - / ~	
⊕	PE	PE conductor	
4	V	Power phase U	
5	V	Power phase V	
6	W	Power phase W	

8-pole (external view of poles)			
Contact	Name	Name	M23
1	V	Power phase U	
⊕	PE	PE conductor	
3	W	Power phase W	
4	V	Power phase V	
A	TB1 / TP1 / R1	Thermal sensor: TCO / PTC / + KTY	
B	TB2 / TP2 / R2		
C	BD1 / BA1	Brake + / AC <250 V	
D	BD2 / BA2	Brake - / AC <250 V	

8-pole (external view of poles) / connection variant ICN 8B			
Contact	Name	Name	M23
1	V	Power phase U	
⊕	PE	PE conductor	
3	W	Power phase W	
4	V	Power phase V	
A	TB1 / TP1 / R1	Thermal sensor TCO / PTC / + KTY	
B	TB2 / TP2 / R2		
C	BD1 / BA 1	Switching contact of rectifier	
D	BD2 / BA2		

Connection variant **ICN 8B** - switching contact of the rectifier for DC switching. Rectifier supply via motor terminal board. Only possible during mains operation!

# 6 Electrical installation

Plug connectors  
Feedback system

## Fan

### ICN, 7-pole

Single-phase (external view of poles)			
Contact	Name	Meaning	M17
⊕	PE	PE conductor	
1	U1	AC fan	
2	U2		
3	Not assigned		
4	U+	DC fan	
5	U-		
6	Not assigned		

Three-phase (external view of poles)			
Contact	Name	Meaning	M17
⊕	PE	PE conductor	
1	U	Fan	
2	Not assigned		
3	V	Fan	
4	Not assigned		
5	Not assigned		
6	W	Fan	

### 6.4.3 Feedback system

#### Resolver / incremental encoder / absolute value encoder

### ICN, 12-pole

Resolver (external view of poles)			
Contact	Name	Meaning	M23
1	+ Ref	Transformer windings (reference windings)	
2	- Ref		
3	not assigned		
4	+COS	Stator windings cosine	
5	-COS		
6	+SIN	Stator windings Sine	
7	-SIN		
8	not assigned		
9	not assigned		
10	Shield	Encoder housing shield	
11	+ KTY	Thermal detector KTY	
12	- KTY		

Incremental encoder / sin/cos absolute value encoder Hiperface (external view of poles)			
Contact	Name	Meaning	M23
1	B	Track B / + SIN	
2	$\bar{A}$	Track A inverse / - COS	
3	A	Track A / + COS	
4	+ U <sub>B</sub>	Supply + Mass	
5	GND		
6	$\bar{Z}$	Zero track inverse / - RS485 Zero track / + RS485	
7	Z		
8	Not assigned		
9	$\bar{B}$	Track B inverse / - SIN	
10	Shield	Encoder housing shield	
11	+ KTY	Thermal detector KTY	
12	- KTY		

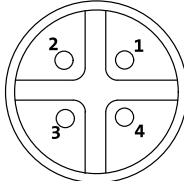

**Circular connector****4-pole**

Incremental encoder (external view of poles)			M12
Contact	Name	Meaning	
1	+ U <sub>B</sub>	Supply +	
2	B	Track B	
3	GND	Mass	
4	A	Track A	

MT plug-in  
connector-001.iso/dms



Further information is provided in the system cables system manual at:

[www.Lenze.de](http://www.Lenze.de) → Download → Technical documentation →  
Finding technical documentation

Filter: Type of contents  
System manual

Filter: Product  
System cable

# 6 Electrical installation

## Terminal box HAN connectors

### 6.5 Terminal box HAN connectors

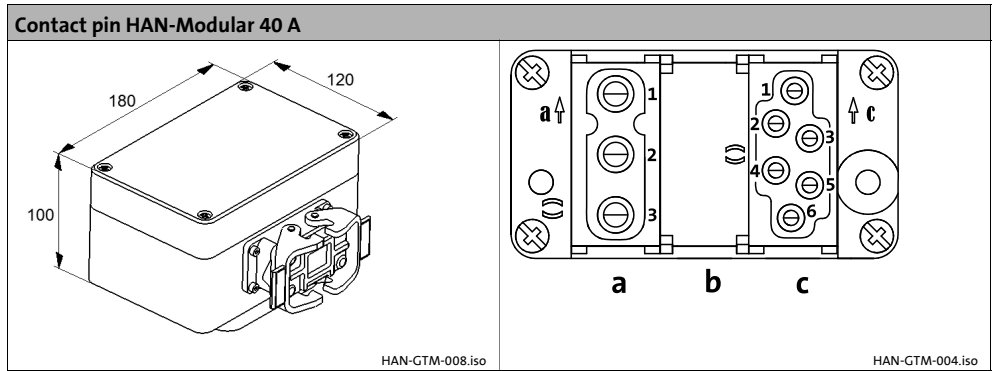
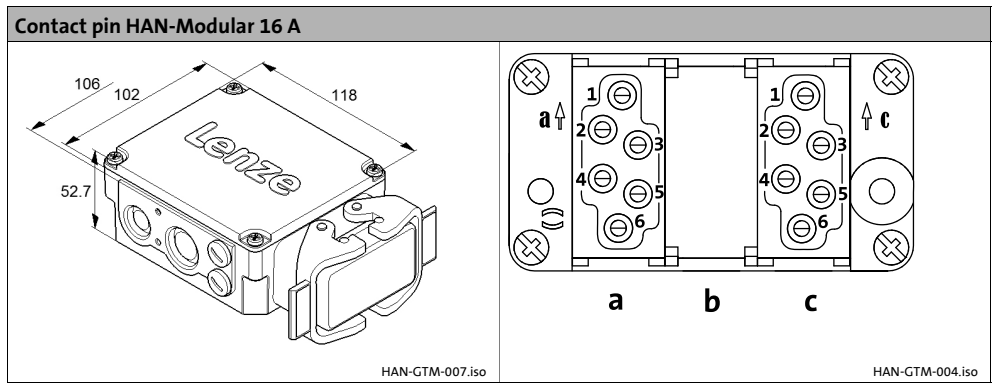

Terminal box			
Module	Contact	Name	Meaning
a	1	U1	Terminal board
	2	V1	Terminal board
	3	W1	Terminal board
b	Blind module		
c	1	+KTY / PTC / TCO	Thermal sensor
	2	+ / AC	Brake
	3	- / AC	Brake
	4	Switching contact	Rectifier
	5		
	6	-KTY / PTC / TCO	Thermal sensor

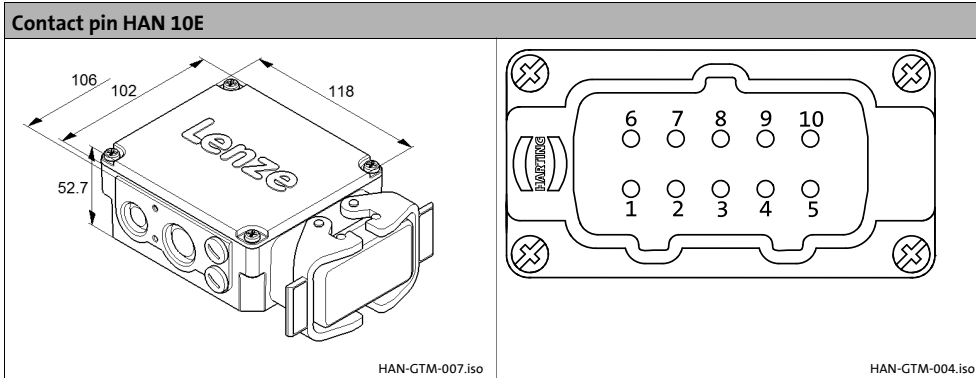

Terminal box		
Contact	Name	Meaning
1	U1	Terminal board
2	V1	
3	W1	
4	+ / AC	Holding brake
5	- / AC	
6	W2	Terminal board
7	U2	
8	V2	
9	+KTY / PTC / TCO	Thermal sensor
10	-KTY / PTC / TCO	



### Note!

Carry out the wiring in  $\Upsilon$  or  $\Delta$  in the counter plug:

- $\Upsilon$  - wiring: 6-7-8
- $\Delta$  - wiring: 1-6/2-7/3-8

# 7 Commissioning and operation

## Important notes

---

### 7.1 Important notes

For trial run without output elements, lock the featherkey. Do not deactivate the protective devices, not even in a trial run.

Check the correct operation of the brake before commissioning motors with brakes.

### 7.2 Before switching on



#### Note!

Before switch-on, you must ensure that the motor starts with the intended direction of rotation.

Lenze motors rotate CW (looking at the driven shaft) if a clockwise three-phase field  $L1 \rightarrow U1$ ,  $L2 \rightarrow V1$ ,  $L3 \rightarrow W1$  is applied.

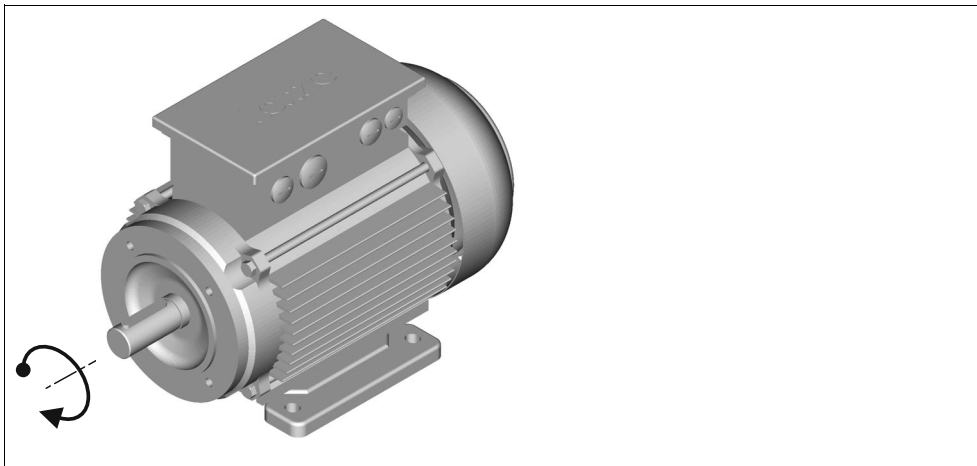

Fig. 3 Direction of rotation of the driven shaft

---

Before initial commissioning, before commissioning after an extended standstill period, or before commissioning after an overhaul of the motor, the following must be checked:

- Measure the insulation resistance, in case of values  $\leq 1 \text{ k}\Omega$  per volt of rated voltage, dry the winding.
- Have all screwed connections of the mechanical and electrical parts been firmly tightened?
- Is the unrestricted supply and removal of cooling air ensured?
- Has the PE conductor been connected correctly?
- Have the protective devices against overheating (temperature sensor evaluation) been activated?
- Is the controller correctly parameterised for the motor?  
(ⓘ Controller operating instructions)
- Are the electrical connections o.k.?
- Does the motor connection have the correct phase sequence?
- Are rotating parts and surfaces which can become very hot protected against accidental contact?
- Is the contact of good electrical conductivity if a PE connection on the motor housing is used?

### 7.3 Functional test

- Check all functions of the drive after commissioning:
- Direction of rotation of the motor
  - Direction of rotation in the disengaged state (see chapter "Electrical connection").
- Torque behaviour and current consumption
- Function of the feedback system

# 7 Commissioning and operation

During operation

---

## 7.4 During operation



### Stop!

- Fire hazard! Do not clean or spray motors with flammable detergents or solvents.
- Avoid overheating! Deposits on the drives impede the heat dissipation required and have to be removed regularly.



### Danger!

During operation, motor surfaces must not be touched. According to the operating status, the surface temperature for motors can be up to 140°C. For the protection against burn injuries, provide protection against contact, if necessary. Observe coolingoff times!

During operation, carry out inspections on a regular basis. Pay special attention to:

- Unusual noises
- Oil spots on drive end or leakages
- Irregular running
- Increased vibration
- Loose fixing elements
- Condition of electrical cables
- Speed variations
- Impeded heat dissipation
  - Deposits on the drive system and in the cooling channels
  - Pollution of the air filter

In case of irregularities or faults, (📖 50).

## 8.1 Important notes



### **Danger!**

Hazardous voltage on the power connections even when disconnected from mains: residual voltage >60 V!

Before working on the power connections, always disconnect the drive component from the mains and wait until the motor is at standstill. Verify safe isolation from supply!

Shaft sealing rings and roller bearings have a limited service life.

Regrease bearings with relubricating devices while the lowvoltage machine is running. Only use the grease recommended by the manufacturer.

If the grease drain holes are sealed with a plug, (IP54 drive end; IP23 drive and nondrive end), remove plug before commissioning. Seal bore holes with grease.

## 8.2 Maintenance intervals

### Inspections

- If the machine is exposed to dirt, clean the air channels regularly.

#### 8.2.1 Motor

- Only the bearings and shaft sealing rings become worn.
  - Check bearings for noise (after approx. 15,000 h at the latest).
- In order to prevent overheating, remove dirt deposits on the drives regularly.
- We recommend carrying out an inspection after the first 50 operating hours. In this way, you can detect and correct any irregularities or faults at an early stage.

#### 8.2.2 Encoder

GB - (Google Test) The guarantor of the engine is a component for use with security features.

### **Danger!**

**If not properly performed work on the guarantor of the motor lead to the loss of safety functions.**

Possible consequence: Property damage and / or personal injury.

Protection measure: Repair or replacement of the collateral provider is allowed only by Lenze Service or its empower people.

After a service life of 10 years, an inspection of the metal elastomer torque plate is required for the AS1024-8V-K, AS1024-8V-K2; AM1024-8V-K, and AM1024-8V-K2 encoders. If no replacement is required, an inspection interval of max. 5 years has to be observed.

# 8 Maintenance/repair

Maintenance operations  
Spring-operated brakes

---

## 8.2.3 Spring-operated brakes

To ensure safe and trouble-free operation, spring-applied brakes must be checked and maintained at regular intervals. Servicing can be made easier if good accessibility of the brakes is provided in the plant. This must be considered when installing the drives in the plant.

Primarily, the necessary maintenance intervals for industrial brakes result from the load during operation. When calculating the maintenance interval, all causes for wear must be taken into account, (☞ 42). For brakes with low loads such as holding brakes with emergency stop, we recommend a regular inspection at a fixed time interval. To reduce the cost, the inspection can be carried out along with other regular maintenance work in the plant if necessary.

If the brakes are not maintained, failures, production losses or damage to the system may occur. Therefore, a maintenance concept adapted to the particular operating conditions and brake loads must be defined for every application. For the spring-applied brakes, the maintenance intervals and maintenance operations listed in the below table must be provided. The maintenance operations must be carried out as described in the detailed descriptions.

Type	Service brake	Holding brake with emergency stop
Spring-applied brake	<ul style="list-style-type: none"><li>• according to service life calculation</li><li>• otherwise every six months</li><li>• after 4,000 operating hours at the latest</li></ul>	<ul style="list-style-type: none"><li>• at least every two years</li><li>• after 1 million cycles at the latest</li><li>• provide shorter intervals in the case of frequent emergency stops</li></ul>

## 8.3 Maintenance operations

### 8.3.1 Motor



#### Stop!

- Make sure that no foreign bodies can enter the inside of the motor!
- Do not remove plugs when voltage is being applied!



### 8.3.2 Spring-operated brakes

The brake is mounted to the N-end shield of the motor. Remove the fan cover or blower unit or the encoder, if available, to check, maintain, or set the brake.



#### Note!

Brakes with defective armature plates, cheese head screws, springs or counter friction faces must always be replaced completely.

Generally observe the following for inspections and maintenance works:

- Remove oil and grease linked impurities using brake cleaning agents, if necessary, replace brake after identifying the cause of the contamination. Dirt deposits in the air gap between stator and armature plate impair the function of the brake and must be removed.
- After replacing the rotor, the original braking torque will not be reached until the run-in operation of the friction surfaces has been completed. After replacing the rotor, run-in armature plates and counter friction faces have an increased initial rate of wear.

#### Wear on spring-applied brakes

The used spring-applied brakes have a low rate of wear and are designed for long maintenance intervals.

However, the friction lining, the teeth between the brake rotor and the hub, and also the braking mechanism are naturally subject to function-related wear which depends on the application case (see table). In order to ensure safe and problem-free operation, the brake must therefore be checked and maintained regularly and, if necessary, replaced (see brake maintenance and inspection).

The following table describes the different causes of wear and their effect on the components of the spring-applied brake. In order to calculate the useful life of the rotor and brake and determine the maintenance intervals to be prescribed, the relevant influencing factors must be quantified. The most important factors are the applied friction energy, the starting speed of braking and the switching frequency. If several of the indicated causes of wear on the friction lining occur in an application, their effects are to be added together.





# 8 Maintenance/repair

## Maintenance operations Checking the component parts

Component	Effect	Influencing factors	Cause
Friction lining	Wear on the friction lining	Applied friction energy	Braking during operation (impermissible, holding brakes!)
			Emergency stops
			Overlapping wear when the drive starts and stops
			Active braking by the drive motor with the help of the brake (quick stop)
		Number of start-stop cycles	Starting wear if motor is mounted in a position with the shaft vertical, even if the brake is open
Armature plate and flange	Running-in of armature plate and flange	Applied friction energy	Friction between the brake lining and the armature plate or flange e.g. during emergency braking or service brake operation
Teeth of the brake rotor	Teeth wear (primarily at the rotor end)	Number of start-stop cycles, Level of the braking torque, Dynamics of the application, Speed fins in operation	Relative movement and impacts between brake rotor and brake hub
Armature plate bracket	Armature plate, cap screws and bolts are deflected	Number of start-stop cycles, Level of braking torque	Load changes and impacts due to reversal error during interaction between armature plate, cap screws and guide bolts
Springs	Fatigue failure of the springs	Number of switching operations of the brake	Axial load cycle and shearing stress on the springs due to radial reversing error of the armature plate

Tab. 1 Causes for wear

### 8.3.3 Checking the component parts

With a mounted brake	<ul style="list-style-type: none"> <li>• Check ventilation function and activation/deactivation  44</li> <li>• Check air gap (if required, re-adjust it)  44</li> <li>• Measure rotor thickness (if required, replace rotor)  43</li> <li>• Thermal damage of the armature plate or flange (tarnished in dark blue)</li> </ul>
With a dismantled brake	<ul style="list-style-type: none"> <li>• Check clearance of the rotor gear teeth (replace rotors that are damaged by vibration)  45</li> <li>• Damage by vibration of the torque support at the sleeve bolts, cylindrical pins, and armature plate</li> <li>• Check springs for damage</li> <li>• Check armature plate and flange or end shield               <ul style="list-style-type: none"> <li>– Evenness for size 06...12 &lt; 0.06 mm</li> <li>– Evenness from size 14 &lt; 0.1 mm</li> <li>– Max. run-in depth = rated air gap of the design size</li> </ul> </li> </ul>

**Check the mounting dimension of the manual release****Stop!**

Dimension "s" must be maintained! Check air gap "s<sub>L</sub>"!  
(📖 operating instructions)

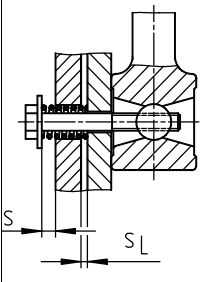

Size	s <sub>L</sub> (mm)	s <sup>+0.1</sup> (mm)	s + s <sub>L</sub> (mm)
06	0.2	1	1.2
08			
10			
12	0.3	1.5	1.8
14			
16			
18	0.4	2	2.4
20			
25	0.5	2.5	3

**8.3.4 Checking the rotor thickness****Danger!**

When the rotor thickness is checked, the motor must not run.

1. Remove fan cover and cover ring if attached.
2. Measure rotor thickness with calliper gauge. If a friction plate is attached, ensure a flanged edge at the outer diameter of the friction plate.
3. Compare measured rotor thickness with minimally permissible rotor thickness (values 📖 45).
4. If required, exchange the entire rotor. Description 📖 45.

**8.3.5 Checking the air gap**

1. Check the air gap "s<sub>L</sub>" near the fixing screws between the armature plate and stator using a feeler gauge (📖 45).
2. Compare air gap measured to maximally permissible air gap "s<sub>L max.</sub>" (📖 45).
3. If required, set air gap to "s<sub>LN</sub>" (📖 44).

## 8 Maintenance/repair

Maintenance operations  
Release / voltage

---

### 8.3.6 Release / voltage



#### **Danger!**

The rotating rotor must not be touched.



#### **Danger!**

Live connections must not be touched.

1. Observe the brake's function while the drive is being operated. The armature plate must be tightened and the rotor must move free of residual torque.
2. Measure the DC voltage on the brake.
  - The DC voltage measured after the overexcitation time (Ⓢ operating instructions, forced voltage rectifier) must equal the voltage for the holding. A deviation of up to  $\pm 10\%$  is permissible.

### 8.3.7 Adjusting the air gap



#### **Danger!**

The brake must be free of residual torque.



#### **Stop!**

For the flange design, please observe the following if the flange is mounted with additional screws:

Clearing holes in the end shield must be provided behind the threaded holes in the flange that are designed for the screws. Without clearing holes, the minimum rotor thickness cannot be utilised fully. In no case must the screws press against the end shield.

1. Loosen screws (10).
2. Screw the sleeve bolts further into the stator using an open-jawed spanner.  $\frac{1}{6}$  revolution reduces the air gap by approx. 0.15 mm.
3. Tighten screws, torques (Ⓢ 45).
4. Check air gap " $s_L$ " near the screws using a feeler gauge, " $s_{Lrated}$ " (Ⓢ 45).
5. If the deviation of " $s_{Lrated}$ " is too great, repeat the adjustment process.

### 8.3.8 Rotor replacement



#### Danger!

The brake must be free of residual torque.

1. Loosen the connecting cable.
2. Evenly release the screws and remove them completely.
3. Completely remove the stator from the end shield. Observe the connecting cables.
4. Completely remove the rotor from the hub.
5. Check the toothed part of the hub.
6. In case of wear, replace the hub, too.
7. Check the friction surface of the end shield. If the flange / friction plate is severely gouged, it must be replaced. If the end shield is severely gouged, the friction surface must be reprocessed.
8. Measure the rotor thickness (new rotor) and the height of head of the sleeve bolts using a caliper gauge.
9. The distance between the stator and the armature plate is calculated as follows:

**Distance = rotor thickness +  $s_{Lrated}$  - height of head**

" $s_{Lrated}$ " (☞ 45)

10. Evenly remove the sleeve bolts until the calculated distance is reached between the stator and the armature plate.
11. Mount and set new complete rotor and stator, (☞ 46).
12. Connect the connecting cable again.

## 8.4 Installation of a spring-applied brake

### 8.4.1 Brake characteristics

Brake size	$s_{LN}$ +0.1 mm -0.05 mm [mm]	$s_{Lmax.}$ service brake [mm]	$s_{Lmax.}$ holding brake [mm]	Max. adjustment, permissible wear path [mm]	Rotor thickness		Tightening torque of the fixing screws [Nm]	
					min. <sup>1)</sup> [mm]	max. [mm]		
06	0.2	0.5	0.3	1.5	4.5	6.0	3.0	
08					5.5	7.0	5.9	
10					7.5	9.0	10.1	
12	0.3	0.75	0.45	2.0	8.0	10.0	10.1	
14					7.5	10.0	24.6	
16					3.5	8.0	11.5	24.6
18	0.4	1.0	0.6	3.0	10.0	13.0	24.6	
20					4.0	12.0	16.0	48.0
25					4.5	15.5	20.0	48.0

Tab. 2 Characteristics of the spring-applied brake

- 1) The dimension of the friction lining allows for adjustment of the brake for at least five times.



1. Check air gap near the screws (10) using a feeler gauge and compare the values to the data for " $s_{Lrated}$ " in the table,  45.

**Note!**

Do not insert feeler gauge further than 10 mm between the armature plate (2) and stator (1)!

If " $s_L$ " ( 45) is not within the tolerance, readjust the air gap.

**8.4.3 Adjusting the air gap****Danger!**

Disconnect voltage. The brake must be free of residual torque.

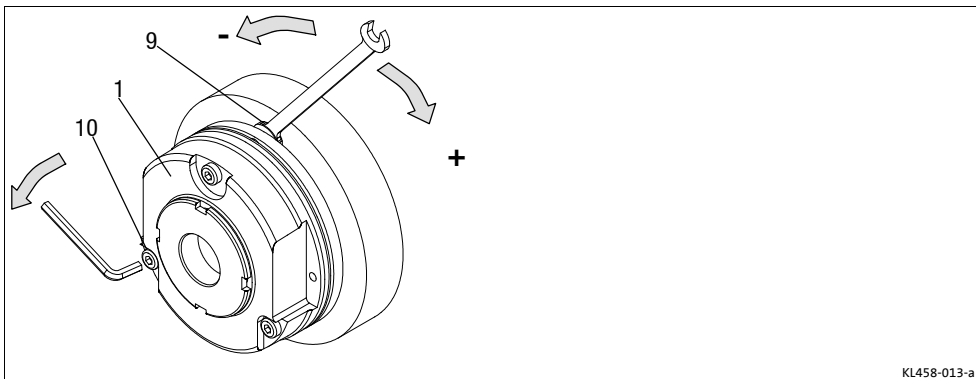

Fig. 6 Re-adjust air gap

- 1 Complete stator
- 9 Sleeve bolt

- 10 Cheese head screw

If the measured value " $s_L$ " is outside the tolerance of " $s_{LN}$ ", set the dimension:

## 8 Maintenance/repair

Installation of a spring-applied brake  
Assembly of the friction plate, sizes 06 to 16

---

### 8.4.4 Assembly of the friction plate, sizes 06 to 16

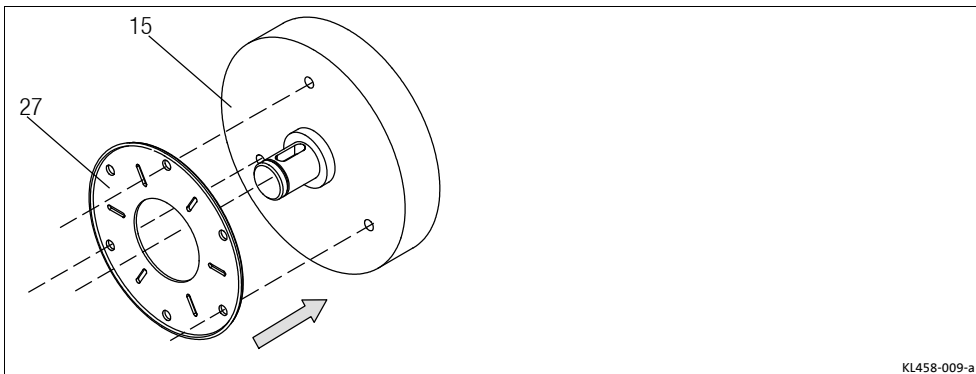

Fig. 7 Friction plate mounting

15 End shield

27 Friction plate

1. Put a friction plate (27) or flange (6) against the end shield (15).



#### Note!

The flanged edge of the friction plate must remain visible!

2. Align pitch circle and fastening bore hole thread.

### 8.4.5 Assembly of the flange

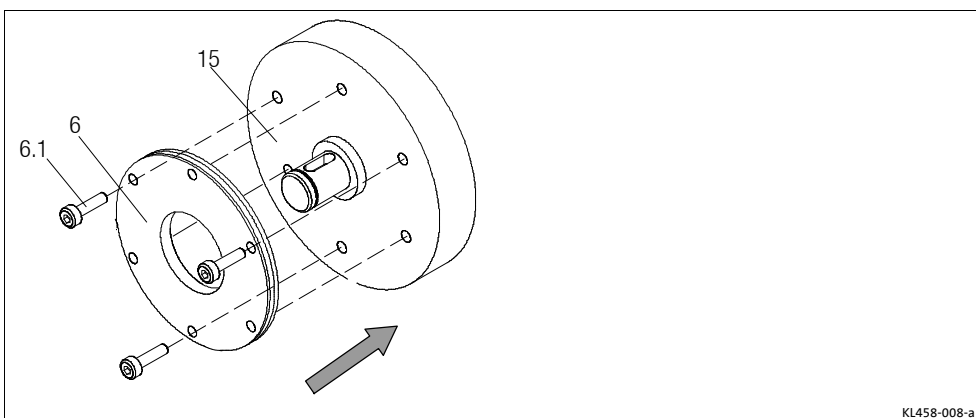

Fig. 8 Flange mounting

6 Flange

15 End shield

6.1 Set of screws

1. Hold the flange (6) against the end shield (15) and check the pitch circle and retaining screw drill hole threading.
2. Fasten the flange (6) on the end shield (15) with the screws (6.1).
3. Tighten the cheese head screws (6.1) evenly, (tightening torques (📖 45).
4. Check the height of the screw heads. The screw heads may not be higher than the minimum rotor thickness. We recommend using screws according to DIN 6912, dimensions (📖 45).



**Mounting the flange without additional screws**

1. Apply the flange (6) to the end shield (15). Check pitch circle and thread of the screw-on bore holes.
2. Mount the brake.

**8.4.6 Assembly of the cover seal**

Fig. 9 Cover ring mounting

1	Complete stator	10	Cheese head screw	15	End shield
2	Armature plate	27	Friction plate		
6	Flange	13	Cover ring		

1. Insert the cable through the cover ring.
2. Push the cover ring over the stator.
3. Press the lips of the cover ring into the groove of rotor and flange.
  - If a friction plate is used, the lip must be pulled over the flanged edge.

**8.5 Repair**

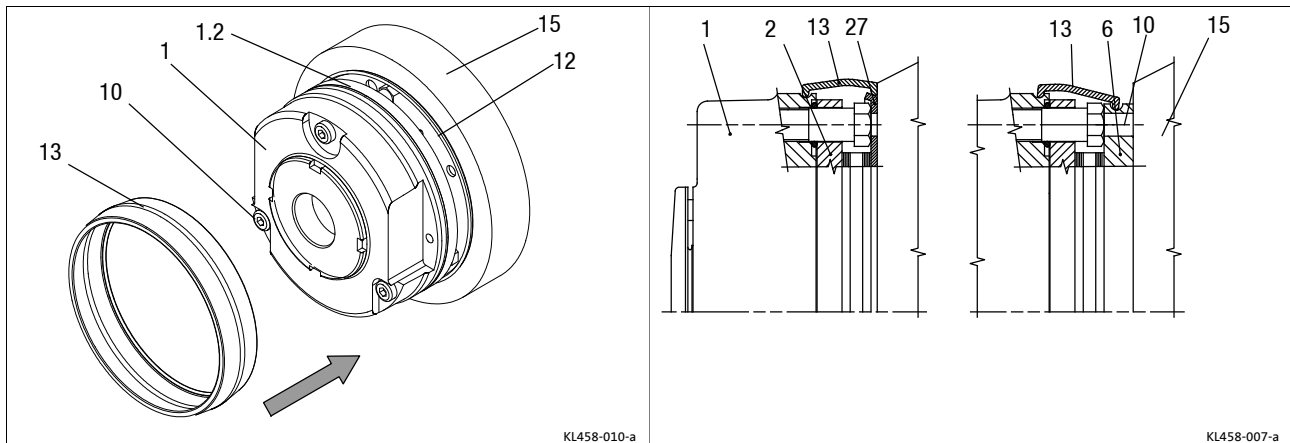
- We recommend having all repairs carried out by the Lenze customer service.

## 9 Troubleshooting and fault elimination

---

If faults occur during operation of the drive system:



- First check the possible causes of malfunction according to the following table.



### **Note!**

Also observe the corresponding chapters in the operating instructions for the other components of the drive system.

If the fault cannot be remedied using one of the listed measures, please contact the Lenze Service.

Fault	Cause	Remedy
Motor too hot  Can only be evaluated by measuring the surface temperature: • Non-ventilated motors > 140 °C • Externally ventilated or self-ventilated motors > 110 °C	Insufficient cooling air, blocked air ducts.	Ensure unimpeded circulation of cooling air
	Preheated cooling air	Ensure a sufficient supply of fresh cooling air
	Overload, with normal mains voltage the current is too high and the speed too low	Use larger drive (determined by power measurement)
	Rated operating mode exceeded (S1 to S8 IEC/EN 60034-1)	Adjust rated operating mode to the specified operating conditions. Determination of correct drive by expert or Lenze customer service
	Loose contact in supply cable (temporary single-phase operation!)	Tighten loose contact
	Fuse has blown (single-phasing!)	Replace fuse
	Overload of the drive	Check load and, if necessary, reduce by means of longer ramp-up times Check winding temperature
Motor does not start	Heat dissipation impeded by deposits	Clean surface and cooling fins of the drives
	Voltage supply interrupted	Check error message on the controller Check electrical connection,  26
	controller inhibited	Check display on the controller Check controller enable
	Fuse has blown	Replace fuse
	Interrupted encoder cable	Check error message on the controller Check encoder cable
	Brake does not release	Check electrical connection,  26 Check air gap,  brake documentation Check continuity of magnetic coil
	Drive blocks	Check components for easy movement, remove foreign particles if necessary
Motor suddenly stops and does not restart	Motor cable with reverse polarity	Check electrical connection,  26
	Overload monitoring of the inverter is activated	Check controller settings Reduce load caused by longer acceleration times
Incorrect direction of rotation of the motor, correct display on the controller	Motor cable polarity is reversed	Check the polarity and correct
	Polarity of encoder cable reversed	
Motor rotates normally but does not reach the expected torque	Motor cable interchanged cyclically Not all motor phases connected	Connect the phases at the motor cable connection correctly
Motor turns in one direction at maximum speed in an uncontrolled manner	Motor cable interchanged cyclically	Check motor connector and, if necessary, correct
	Polarity of encoder cable reversed	Check encoder connection and, if necessary, correct
Motor rotates slowly in one direction and cannot be influenced by the controller	Polarity of motor cable and encoder cable reversed	Check the polarity and correct
Irregular running	Insufficient shielding of motor or resolver cable	Checking shielding and earth connection
	Drive controller gain too large	Adjust the gains of the controllers (see Drive controller operating instructions)
Vibrations	Insufficiently balanced coupling elements or machine	Rebalance
	Inadequate alignment of drive train	Realign machine unit, check foundation if necessary
	Loose fixing screws	Check and tighten screw connections
Running noises	Foreign particles inside the motor	Repair by manufacturer if necessary
	Bearing damage	
Surface temperature > 140 °C	Overload of the drive	Check load and, if necessary, reduce by means of longer ramp-up times Check winding temperature
		Check winding temperature
	Heat dissipation impeded by deposits	Clean surface and cooling fins of the drives

# 10 Appendix

Technical data as specified by ordinances (EU) No. 4/2014 and (EC) No. 640/2009

## 10.1 Technical data as specified by ordinances (EU) No. 4/2014 and (EC) No. 640/2009

This chapter includes the technical data in compliance with the specifications laid down by ordinances (EU) No. 4/2014 and (EC) No. 640/2009.

Annex 1 Clause 2 of ordinance (EC) No. 640/2009 stipulates the publication of the following technical data in the fixed order 1 ... 12:

No.	Meaning
1	Rated efficiency ( $\eta$ ) at 100 %, 75 % and 50 % of the rated load and rated voltage ( $U_{\text{rated}}$ )
2	Efficiency level: "IE2" or "IE3"
3	Year of manufacture
4	Name or trademark, official registration number and manufacturer's place of establishment
5	Model number of the product
6	Number of poles of the motor
7	Rated output power(s) or rated output power interval [kW]
8	Rated input frequency (frequencies) of the motor [Hz]
9	Rated voltage(s) or rated voltage interval [V]
10	Rated speed(s) or rated speed interval [rpm]
11	Relevant information for the disassembly, recycling or disposal after the final decommissioning
12	Information regarding the range of operating conditions for which the motor is specially designed:
	i) Altitudes above sea level
	ii) Ambient air temperatures, also for motors with air cooling
	iii) Cooling fluid temperature at the inlet of the product
	iv) Maximum operating temperature
	v) Hazardous areas

Technical data in compliance with ordinance (EC) No. 640/2009										
No.	MH□MA 080...132 motors									
1	$\eta_{100\%}$	[%]	79.6	82.0	82.8	86.3	85.5	88.3	89.2	88.7
	$\eta_{75\%}$	[%]	79.6	81.6	83.4	86.7	85.6	88.2	89.3	88.9
	$\eta_{50\%}$	[%]	74.9	77.4	82.2	85.4	83.8	86.3	88.2	87.6
2			IE2	IE2	IE2	IE2	IE2	IE2	IE2	IE2
3			For year of manufacture and week of manufacture see nameplate: □ 16							
4			Lenze Drives GmbH, Breslauer Straße 3, D-32699 Extertal, GERMANY, HR Lemgo B 6478							
5	Motor code		MH□MA □□080-32	MH□MA □□090-12	MH□MA □□090-32	MH□MA □□100-12	MH□MA □□100-32	MH□MA □□112-22	MH□MA □□132-12	MH□MA □□132-22
6	Number of poles		4	4	4	4	4	4	4	4
7	$P_{\text{rated}}$	[kW]	0.75	1.1	1.5	2.2	3.0	4.0	5.5	7.5
8	$f_r$	[Hz]	50	50	50	50	50	50	50	50
9	$V_{\text{rated}}$	[V]	400	400	400	400	400	400	400	400
10	$n_r$	[rpm]	1410	1430	1435	1445	1445	1455	1470	1460
11			Information regarding the disposal: □ 12							
12										
	i)		Permissible installation height: □ 18							
	ii)		Permissible ambient air temperatures: □ 18							
	iii)		Not relevant, since motors are not liquid-cooled.							
	iv)		Maximum operating temperature: 155 °C (temperature class F)							
	v)		Operation in hazardous areas prohibited.							

Technical data in compliance with ordinance (EC) No. 640/2009										
No.	MH□MA 160...225 motors									
<b>1</b>	η <sub>100%</sub>	[%]	89.8	90.6	91.2	91.6	92.3	92.3	94.3	94.3
	η <sub>75%</sub>	[%]	90.0	90.8	91.4	92.0	92.5	92.5	94.6	94.5
	η <sub>50%</sub>	[%]	89.4	90.2	90.8	91.4	91.9	91.9	94.0	93.7
<b>2</b>			IE3	IE3	IE3	IE3	IE3	IE3	IE3	IE3
<b>3</b>	Fertigungsjahr und Fertigungswoche siehe Typenschild: □ 16									
<b>4</b>	Lenze Drives GmbH, Breslauer Straße 3, D-32699 Extertal, GERMANY, HR Lemgo B 6478									
<b>5</b>	Motor code		MH□MA □□160-22	MH□MA □□160-32	MH□MA □□180-12	MH□MA □□180-32	MH□MA □□180-42	MH□MA □□200-32	MH□MA □□225-12	MH□MA □□225-22
<b>6</b>	Number of poles		4	4	4	4	4	4	4	4
<b>7</b>	P <sub>rated</sub>	[kW]	11.0	15.0	18.5	22.0	30.0	30.0	37.0	45.0
<b>8</b>	f <sub>r</sub>	[Hz]	50	50	50	50	50	50	50	50
<b>9</b>	V <sub>rated</sub>	[V]	400	400	400	400	400	400	400	400
<b>10</b>	n <sub>r</sub>	[rpm]	1470	1470	1475	1470	1465	1465	1483	1480
<b>11</b>	Information regarding the disposal: □ 12									
<b>12</b>										
i)	Permissible installation height: □ 18									
ii)	Permissible ambient air temperatures: □ 18									
iii)	Not relevant, since motors are not liquid-cooled.									
iv)	Maximum operating temperature: 155 °C (temperature class F)									
v)	Operation in hazardous areas prohibited.									



## Notes

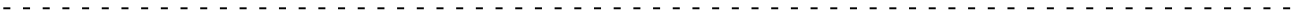

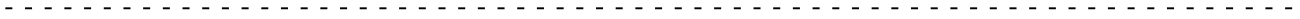



Lenze Drives GmbH  
Postfach 10 13 52, 31763 Hameln  
Breslauer Straße 3, 32699 Extertal  
GERMANY  
HR Lemgo B 6478

☎ +49 5154 82-0

📠 +49 5154 82-2800

@ lenze@lenze.com

🌐 www.lenze.com



Lenze Service GmbH  
Breslauer Straße 3, D-32699 Extertal

Germany

☎ 0080002446877 (24 h helpline)

📠 +49 5154 82-1112

@ service@lenze.com

10 9 8 7 6 5 4 3 2 1