



**ALTA EFFICIENZA - HIGH EFFICIENCY**

I dati tecnici riportati nel presente catalogo non sono impegnativi.  
Felm si riserva il diritto e la facoltà di apportare modifiche in qualsiasi momento senza preavviso.

The technical data listed in this catalogue may not be considered as binding.  
Felm reserves the right to make modifications at any time without notice.

## MOTORI EFF1

Il sistema è stato studiato affinché tutti gli utenti di motori elettrici trattino con la massima importanza l'efficienza del motore. L'obiettivo finale è di arrivare all'uso di motori che rientrino in una "banda" di alta efficienza che dovrebbe, secondo le aspettative della Commissione Europea, tradursi in un risparmio energetico e di conseguenza in una riduzione delle emissioni nocive delle centrali elettriche.



### Vantaggi per l'utente

L'uso di motori a risparmio energetico costituisce un vantaggio economico in quanto:

- un rendimento energetico superiore riduce le perdite ed abbatte i costi
- più si usa il motore, più forte è il risparmio
- riduce il periodo di recupero del capitale

Oltre a semplificare la classificazione, il sistema rispetta l'ambiente in quanto:

- la classificazione dei motori in 3 bande di efficienza ne facilita la selezione e l'acquisto per particolari applicazioni:
  - uso occasionale - motori di classe 3
  - uso continuato - motori di classe 2 o 1
- risparmio energetico di considerazione ambientale documentato
- snellimento della prassi di selezione del motore tenendo conto del rendimento energetico

### Rendimento dei motori elettrici

Il motore elettrico converte l'energia elettrica in potenza meccanica rotativa, direttamente ove richiesta.

Una delle caratteristiche inerenti ai motori ad alto rendimento è che ad un anche minimo incremento del coefficiente di rendimento corrisponde un forte risparmio energetico in termini percentuali.

In un motore di alta potenza - ad esempio da 90kW - ad un miglioramento di rendimento del 1% corrisponde una riduzione di perdite pari al 20%.

### Considerazioni

- i motori ad alto rendimento funzionano a temperatura ridotta ed hanno una durata maggiore
- interventi governativi, quali la carbon tax, sono destinati a far salire i costi energetici oltre il tasso d'inflazione
- i motori della banda EFF3 sono destinati a scomparire nei prossimi anni. Per nuove installazioni è certamente consigliabile passare ai motori di una banda di rendimento superiore

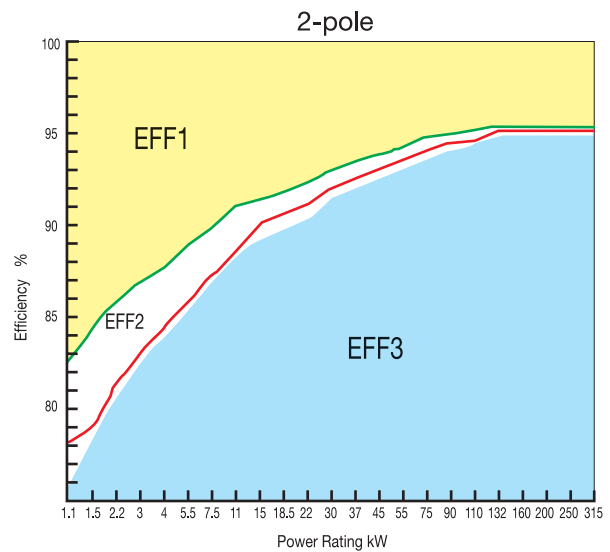
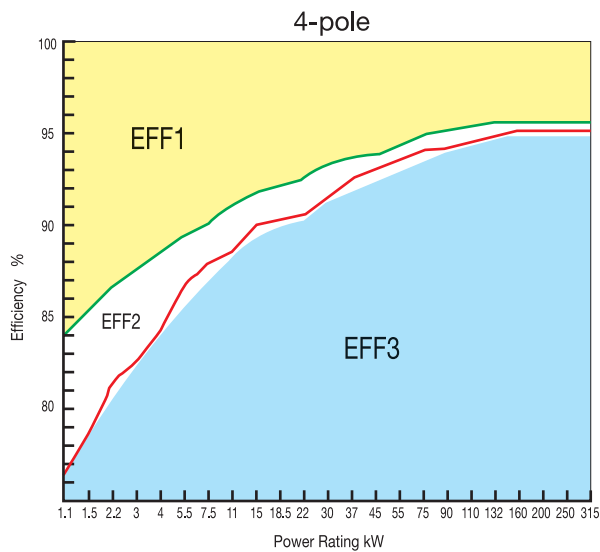

Efficiency of Y2E1

Efficiency of Y2E2

• si applica ai seguenti tipi di motore:

- motori trifase a induzione con gabbia di scoiattolo, carcassa chiusa con raffreddamento a ventola
- solo modelli a 2 e 4 poli
- campo di resa da 1.1 a 90 kW
- tensione nominale 400V , 50 Hz,
- Servizio S1
- configurazione standard, designata Design N, definita in EN 600 34-12 e HD 231

• 2 valori di rendimento a carico massimo SONO

assegnati per ogni potenza resa di motore standard

- potenza resa secondo IEC 34
- rendimento misurato secondo IEC 600034-2 (1972), Emendamento 1 (1995) ed Emendamento 2 (1996)

• sono fissate 3 bande di livello per il rendimento

- bande chiamate EFF1, EFF2 ed EFF3
- vedi tabelle e diagramma in questa pagina

• i dati sono riportati sulla targhetta del motore e sulle tabelle delle schede tecniche pubblicate sui cataloghi

Modelli a 2 poli			
kW	% rendimento		
	EFF1 pari o superiore a	EFF2 pari o superiore a	EFF3 inferiore
1.1	82.8	76.2	
1.5	84.1	78.5	
2.2	85.6	81.0	
3	86.7	82.6	
4	87.6	84.2	
5.5	88.6	85.7	
7.5	89.5	87.5	
11	90.5	88.4	
15	91.3	89.4	
18.5	91.8	90.0	
22	92.2	90.5	
30	92.9	91.4	
37	93.3	92.0	
45	93.7	92.5	
55	94.0	93.0	
75	94.6	93.6	
90	95.0	93.9	

Modelli a 4 poli			
kW	% rendimento		
	EFF1 pari o superiore a	EFF2 pari o superiore a	EFF3 inferiore
1.1	83.8	76.2	
1.5	85.0	78.5	
2.2	86.4	81.0	
3	87.4	82.6	
4	88.3	84.2	
5.5	89.2	85.7	
7.5	90.1	87.0	
11	91.0	88.4	
15	91.8	89.4	
18.5	92.2	90.0	
22	92.6	90.5	
30	93.2	91.4	
37	93.6	92.0	
45	93.9	92.5	
55	94.2	93.0	
75	94.7	93.6	
90	95.0	93.9	

## SPECIFICHE TECNICHE 2 POLI TECHNICAL SPECIFICATION 2 POLE

Motor Type	Rated output		Full load						Locked Current	Locked Torque	Break-down Torque	moment of inertia J	weight
			Current A		Speed r/min	Power factor COSØ	Efficiency η%	Rated Current					
	kW	HP	380V	400V					kgm²	kg			
HJN 80M <sub>1</sub> -2	0.75	1.0	1.78	1.69	2860	0.811	79.03	7.01	3.08	3.38	0.0009	17.0	
EFF1 HJN 80M <sub>2</sub> -2	1.1	1.5	2.42	2.30	2865	0.832	84.07	7.54	3.22	3.55	0.0010	18.0	
EFF1 HJN 90S-2	1.5	2.0	3.16	3.00	2875	0.832	85.26	7.95	3.09	3.40	0.0012	23.0	
EFF1 HJN 90L-2	2.2	3.0	4.52	4.29	2865	0.867	85.66	8.19	3.76	3.62	0.0014	26.0	
EFF1 HJN 100L-2	3.0	4.0	5.89	5.60	2860	0.890	86.70	7.09	2.77	3.12	0.0030	34.0	
EFF1 HJN 112M-2	4.0	5.5	7.47	7.10	2880	0.923	88.00	6.90	2.04	3.14	0.0056	41.0	
EFF1 HJN 132S <sub>1</sub> -2	5.5	7.5	10.4	9.90	2925	0.893	89.70	7.98	2.14	3.58	0.0104	60.0	
EFF1 HJN 132S <sub>2</sub> -2	7.5	10	14.4	13.7	2925	0.876	90.00	8.60	2.07	3.91	0.0125	63.0	
EFF1 HJN 160M <sub>1</sub> -2	11	15	20.4	19.4	2945	0.901	90.96	7.50	2.18	3.49	0.0372	109	
EFF1 HJN 160M <sub>2</sub> -2	15	20	27.5	26.1	2940	0.903	91.74	7.39	2.08	3.40	0.0435	119	
EFF1 HJN 160L-2	18.5	25	33.4	31.7	2935	0.919	91.73	7.10	2.15	3.27	0.0527	136	
EFF1 HJN 180M-2	22	30	39.8	37.8	2950	0.909	92.33	7.99	2.60	3.73	0.0712	172	
EFF1 HJN 200L <sub>1</sub> -2	30	40	53.4	50.7	2950	0.917	93.11	7.50	2.26	3.31	0.1192	223	
EFF1 HJN 200L <sub>2</sub> -2	37	55	65.7	62.4	2950	0.918	93.33	7.55	2.24	3.30	0.1333	242	
EFF1 HJN 225M-2	45	60	79.9	75.9	2965	0.913	93.76	7.35	3.35	3.42	0.2214	302	
EFF1 HJN 250M-2	55	75	96.8	92.0	2970	0.912	94.58	7.99	2.05	3.62	0.3055	382	
EFF1 HJN 280S-2	75	100	134	127	2975	0.904	94.67	6.33	2.11	3.19	0.5845	515	
EFF1 HJN 280M-2	90	125	160	152	2980	0.897	95.32	8.06	2.80	4.08	0.6655	545	
HJN 315S-2	110	150	195	185	2975	0.904	95.09	6.30	1.97	3.15	1.1310	930	
HJN 315M-2	132	180	234	222	2975	0.902	95.45	5.67	1.73	2.77	1.7470	980	
HJN 315L <sub>1</sub> -2	160	215	280	266	2980	0.905	95.83	6.70	2.02	3.28	2.0070	1090	
HJN 315L <sub>2</sub> -2	200	270	350	333	2985	0.903	96.11	5.88	1.84	3.05	2.2690	1190	
HJN 355M-2	250	340	441	419	2985	0.897	96.09	6.49	1.90	3.17	3.2960	1710	
HJN 355L <sub>1</sub> -2	280	375	490	465	2985	0.902	96.34	6.97	1.97	3.22	3.8470	1870	
HJN 355L <sub>2</sub> -2	315	420	532	505	2985	0.933	96.45	7.46	1.93	3.64	3.8470	1870	
HJN 355L <sub>2</sub> -2	355	475	603	573	2985	0.927	96.47	6.38	1.83	2.87	3.9570	2030	
HJN 400M <sub>1</sub> -2	355	475	617	586	2985	0.906	96.51	6.81	1.90	3.22	/	2880	
HJN 400M <sub>2</sub> -2	400	530	693	658	2985	0.907	96.69	6.94	1.94	3.28	/	2980	
HJN 400M <sub>3</sub> -2	450	600	779	740	2985	0.908	96.72	6.88	1.91	3.20	/	3230	
HJN 400L <sub>1</sub> -2	500	665	859	816	2985	0.913	96.84	7.17	1.95	3.31	/	3280	
HJN 400L <sub>2</sub> -2	560	745	958	910	2985	0.917	96.87	7.08	1.99	3.35	/	3330	

## SPECIFICHE TECNICHE 4 POLI TECHNICAL SPECIFICATION 4 POLE

Motor Type	Rated output		Full load					Locked Current	Locked Torque	Break-down Torque	moment of inertia J	weight
			Current A		Speed r/min	Power factor COSØ	Efficiency η%					
	kW	HP	380V	400V				Rated Current	Rated Torque	Rated Torque	kgm <sup>2</sup>	kg
HJN 80M <sub>1</sub> -4	0.55	0.75	1.38	1.31	1405	0.745	81.11	5.35	2.83	3.57	0.0019	18.0
HJN 80M <sub>2</sub> -4	0.75	1.0	1.79	1.70	1410	0.767	82.85	5.87	2.94	3.42	0.0021	19.0
 HJN 90S-4	1.1	1.5	2.63	2.50	1420	0.764	84.03	7.25	3.58	3.45	0.0022	23.0
 HJN 90L-4	1.5	2.0	3.37	3.20	1420	0.786	85.07	6.98	3.65	3.35	0.0028	29.0
 HJN 100L <sub>1</sub> -4	2.2	3.0	4.84	4.60	1440	0.793	86.45	7.93	2.99	3.53	0.0056	35.0
 HJN 100L <sub>2</sub> -4	3.0	4.0	6.42	6.10	1460	0.811	88.00	6.21	2.19	2.79	0.0070	39.0
 HJN 112M-4	4.0	5.5	8.10	7.70	1445	0.842	88.52	7.31	2.47	3.44	0.0091	45.0
 HJN 132S-4	5.5	7.5	11.5	10.9	1455	0.808	89.40	7.18	2.40	3.31	0.0210	62.0
 HJN 132M-4	7.5	10	15.3	14.5	1460	0.826	90.32	7.81	2.50	3.80	0.0311	74.0
 HJN 160M-4	11	15	21.8	20.7	1465	0.843	91.04	6.95	2.08	2.81	0.0732	115
 HJN 160L-4	15	20	29.5	28.0	1470	0.842	91.85	7.48	2.26	3.09	0.0942	135
 HJN 180M-4	18.5	25	35.2	33.4	1470	0.865	92.41	7.34	2.24	3.48	0.1355	170
 HJN 180L-4	22	30	42.0	39.9	1470	0.858	92.70	7.07	2.14	3.25	0.1365	184
 HJN 200L-4	30	40	53.6	50.9	1470	0.912	93.21	6.46	2.29	2.81	0.2455	235
 HJN 225S-4	37	55	69.4	65.9	1475	0.865	93.62	6.39	2.10	2.89	0.3910	290
 HJN 225M-4	45	60	83.6	79.4	1475	0.870	93.94	6.62	2.01	2.99	0.4510	326
 HJN 250M-4	55	75	100	95.3	1480	0.881	94.44	7.44	2.25	3.28	0.6410	385
 HJN 280S-4	75	100	133	126	1485	0.901	95.02	6.75	2.05	3.35	1.0450	515
 HJN 280M-4	90	125	160	152	1485	0.896	95.15	6.88	2.08	3.37	1.3970	605
HJN 315S-4	110	150	199	189	1485	0.881	95.60	6.10	2.21	3.16	2.9810	931
HJN 315M-4	132	180	240	228	1485	0.876	95.67	5.80	2.16	3.05	3.4810	1017
HJN 315L <sub>1</sub> -4	160	215	285	271	1486	0.890	95.75	6.05	2.01	3.00	3.9620	1085
HJN 315L <sub>2</sub> -4	200	270	358	340	1485	0.885	95.92	6.00	2.20	2.98	4.4720	1200
HJN 355M-4	250	340	443	420	1490	0.893	96.11	5.84	1.98	2.92	7.1660	1740
HJN 355L <sub>1</sub> -4	280	375	493	468	1490	0.895	96.45	6.37	2.47	3.04	7.9100	1870
HJN 355L <sub>2</sub> -4	315	420	556	528	1490	0.892	96.51	6.73	2.14	3.23	8.7100	1975
HJN 355L <sub>3</sub> -4	355	475	622	591	1490	0.897	96.62	6.08	2.01	2.74	11.190	2025
HJN 400M <sub>1</sub> -4	355	475	624	593	1490	0.894	96.65	6.69	1.44	2.92	14.680	2980
HJN 400M <sub>2</sub> -4	400	535	705	670	1490	0.892	96.67	6.37	1.35	2.87	14.890	3030
HJN 400M <sub>3</sub> -4	450	600	783	744	1490	0.901	96.84	6.61	1.43	3.03	15.100	3080
HJN 400L <sub>1</sub> -4	500	670	868	824	1490	0.903	96.93	6.21	1.30	2.88	18.450	3290
HJN 400L <sub>2</sub> -4	560	750	984	935	1490	0.892	96.94	7.11	1.70	3.50	19.550	3390
HJN 400L <sub>3</sub> -4	630	840	1103	1048	1490	0.894	97.10	6.57	1.53	2.95	21.150	3460

SPECIFICHE TECNICHE 6 POLI  
TECHNICAL SPECIFICATION 6 POLE

Motor Type	Rated output		Full load					Locked Current	Locked Torque	Break-down Torque	moment of inertia J	weight
			Current A		Speed r/min	Power factor COSØ	Efficiency η%					
	kW	HP	380V	400V				Rated Current	Rated Torque	Rated Torque	kgm <sup>2</sup>	kg
HJN 80M <sub>2</sub> -6	0.55	0.75	1.54	1.46	910	0.716	75.94	3.59	2.37	2.71	0.0022	20.0
HJN 90S-6	0.75	1.0	2.02	1.92	920	0.722	78.11	4.31	2.32	2.64	0.0030	24.0
HJN 90L-6	1.1	1.5	2.87	2.72	920	0.727	80.21	4.41	2.21	2.83	0.0036	26.0
HJN 100L-6	1.5	2.0	3.52	3.34	930	0.789	82.14	6.10	2.38	3.34	0.0070	34.0
HJN 112M-6	2.2	3.0	4.95	4.70	945	0.807	83.76	6.32	2.20	3.31	0.0130	40.0
HJN 132S-6	3.0	4.0	6.63	6.29	965	0.785	87.63	5.98	1.94	3.07	0.0275	57.0
HJN 132M <sub>1</sub> -6	4.0	5.5	8.87	8.42	965	0.794	86.33	5.73	1.92	2.78	0.0345	73.0
HJN 132M <sub>2</sub> -6	5.5	7.5	11.9	11.3	965	0.801	87.67	5.82	1.98	2.89	0.0434	77.0
HJN 160M-6	7.5	10	15.9	15.1	965	0.801	89.30	6.01	2.23	2.94	0.0802	110
HJN 160L-6	11	15	23.3	22.1	965	0.796	90.27	6.27	2.24	2.72	0.1085	133
HJN 180L-6	15	20	30.3	28.8	975	0.826	91.13	6.37	2.47	3.04	0.1672	174
HJN 200L <sub>1</sub> -6	18.5	25	36.1	34.3	975	0.849	91.75	6.47	2.14	3.08	0.3020	219
HJN 200L <sub>2</sub> -6	22	30	42.9	40.8	975	0.846	92.07	6.76	2.15	3.09	0.3420	228
HJN 225M-6	30	40	58.7	55.7	980	0.838	92.73	6.02	2.09	2.91	0.5250	296
HJN 250M-6	37	55	69.5	66.0	980	0.867	93.35	5.62	1.90	2.92	0.8080	412
HJN 280S-6	45	60	84.2	80.0	985	0.867	93.67	6.48	1.98	2.99	1.3340	470
HJN 280M-6	55	75	102	96.5	985	0.876	93.94	6.87	2.11	3.00	1.5980	545
HJN 315S-6	75	100	143	136	990	0.844	94.52	6.06	1.80	2.92	3.9390	866
HJN 315M-6	90	125	172	164	990	0.837	94.78	6.14	1.99	2.90	4.5790	948
HJN 315L <sub>1</sub> -6	110	150	205	195	990	0.855	95.21	5.98	1.89	2.86	5.2280	1120
HJN 315L <sub>2</sub> -6	132	180	242	230	990	0.868	95.30	6.09	1.97	2.90	5.5390	1185
HJN 355M <sub>1</sub> -6	160	215	280	266	990	0.908	95.64	7.01	1.87	3.40	9.2650	1705
HJN 355M <sub>2</sub> -6	180	240	317	301	990	0.903	95.67	6.89	1.70	3.03	9.5180	1785
HJN 355M <sub>3</sub> -6	200	270	350	332	990	0.908	95.62	6.75	1.89	3.35	10.760	1890
HJN 355L <sub>2</sub> -6	250	340	446	424	990	0.885	96.13	6.67	1.88	3.25	12.855	2000
HJN 355L <sub>3</sub> -6	280	375	498	474	990	0.887	96.22	7.07	1.87	3.30	14.885	2080
HJN 400M <sub>1</sub> -6	315	420	565	537	990	0.881	96.17	6.53	1.37	2.87	18.013	3530
HJN 400M <sub>2</sub> -6	355	475	639	607	995	0.875	96.43	6.67	1.27	2.98	19.050	3410
HJN 400L <sub>1</sub> -6	400	535	720	684	995	0.874	96.57	7.08	1.46	3.18	21.700	3830
HJN 400L <sub>2</sub> -6	450	600	798	758	995	0.887	96.60	6.53	1.22	2.92	22.020	3900
HJN 400L <sub>3</sub> -6	500	670	902	857	995	0.871	96.67	7.11	1.52	3.42	23.420	3995

**SPECIFICHE TECNICHE 8 POLI**  
**TECHNICAL SPECIFICATION 8 POLE**

Motor Type	Rated output		Full load					Locked Current	Locked Torque	Break-down Torque	moment of inertia J	weight
			Current A		Speed r/min	Power factor COSØ	Efficiency η%					
	kW	HP	380V	400V				Rated Current	Rated Torque	Rated Torque	kgm <sup>2</sup>	kg
HJN 160M <sub>2</sub> -8	5.5	7.5	13.1	12.5	720	0.738	86.22	6.17	2.38	3.27	0.0820	109
HJN 160L-8	7.5	10	16.7	15.9	720	0.765	89.17	5.93	2.13	3.02	0.1142	131
HJN 180M-8	11	15	24.6	23.3	725	0.762	89.30	6.33	2.27	2.89	0.1675	173
HJN 200L-8	15	20	33.4	31.7	730	0.757	90.21	6.28	2.25	2.83	0.3255	234
HJN 225S-8	18.5	25	40.9	38.9	730	0.760	90.34	6.57	2.20	2.85	0.4825	276
HJN 225M-8	22	30	46.2	43.8	735	0.790	91.67	6.77	2.11	2.87	0.5325	298
HJN 250M-8	30	40	61.7	58.6	735	0.802	92.18	5.95	2.05	2.81	0.8100	375
HJN 280S-8	37	55	74.5	70.7	735	0.810	93.20	5.63	2.08	2.67	1.3830	480
HJN 280M-8	45	60	92.2	87.6	740	0.793	93.54	5.80	2.10	2.71	1.7230	560
HJN 315S-8	55	75	111	105	740	0.801	93.96	5.07	1.67	2.63	4.5910	915
HJN 315M-8	75	100	149	141	740	0.812	94.44	6.01	2.04	2.65	5.3600	991
HJN 315L <sub>1</sub> -8	90	125	178	169	740	0.813	94.66	6.13	2.05	2.71	6.1110	1083
HJN 315L <sub>2</sub> -8	110	150	215	204	740	0.819	95.04	5.92	2.01	2.62	6.5500	1174
HJN 355M <sub>1</sub> -8	132	180	251	239	745	0.838	95.21	6.55	1.83	3.04	12.840	1815
HJN 355M <sub>2</sub> -8	160	215	300	285	745	0.847	95.68	5.72	1.67	2.75	14.320	1905
HJN 355L <sub>1</sub> -8	180	240	339	322	745	0.841	95.82	6.11	1.75	2.95	14.950	1985
HJN 355L <sub>2</sub> -8	200	270	378	359	745	0.840	95.71	5.84	1.73	2.91	15.800	2060
HJN 400M <sub>1</sub> -8	250	335	487	462	745	0.812	96.12	6.72	1.42	3.32	25.400	3145
HJN 400M <sub>2</sub> -8	280	375	535	508	745	0.826	96.27	6.49	1.35	3.25	26.300	3165
HJN 400L <sub>1</sub> -8	315	425	590	561	745	0.842	96.33	6.57	1.30	3.14	27.500	3175
HJN 400L <sub>2</sub> -8	355	475	665	632	745	0.841	96.40	5.93	1.16	2.88	29.120	3205
HJN 400L <sub>3</sub> -8	400	535	746	709	745	0.844	96.47	5.81	1.14	2.92	31.020	3235



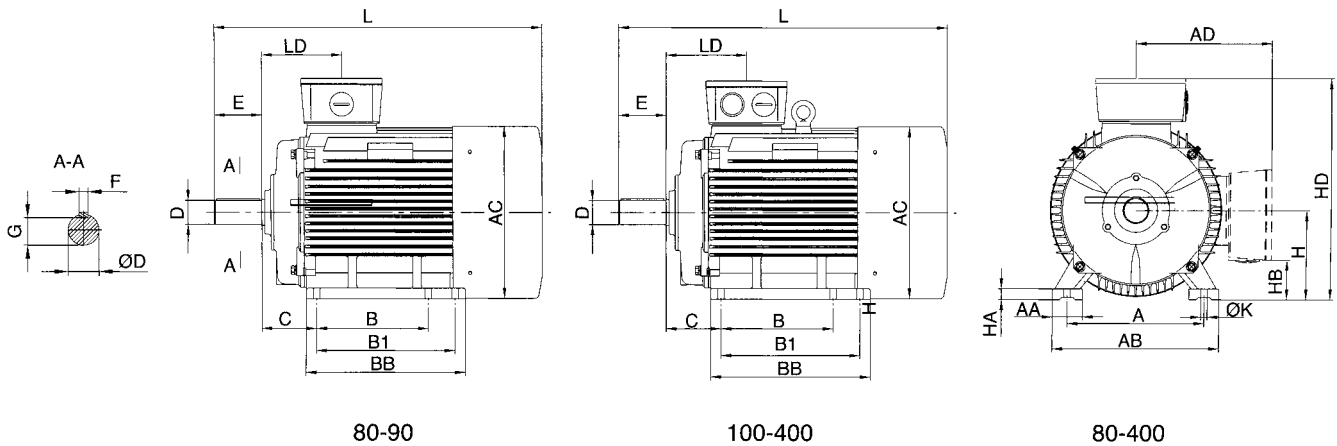

◆ B3

Frame size	Pole	Mounting dimensions (mm)											Overall dimensions (mm)										
		A	B	B1	B2	B3	C	D	E	F	G	H	K	AB	AC	AD	HD	BB	LD	HA	HB	AA	L
80M	2-6	125	100	/	/	/	50	19	40	6	15.5	80	10	160	160	145	225	130	100	12	35	35	280
90S	2-6	140	100	/	/	/	56	24	50	8	20	90	10	180	175	155	245	140	105	12	50	35	315
90L	2-6	140	125	/	/	/	56	24	50	8	20	90	10	180	175	155	245	165	120	12	50	35	340
100L	2-6	160	140	/	/	/	63	28	60	8	24	100	12	200	200	180	270	175	130	14	55	40	375
112M	2-6	190	140	/	/	/	70	28	60	8	24	112	12	230	225	190	305	180	145	17	60	45	400
132S	2-6	216	140	/	/	/	89	38	80	10	33	132	12	265	260	210	345	190	165	18	65	55	465
132M	2-6	216	178	/	/	/	89	38	80	10	33	132	12	265	260	210	345	230	185	18	65	55	505
160M	2-8	254	210	/	/	/	108	42	110	12	37	160	15	315	315	260	415	260	212	20	80	65	600
160L	2-8	254	254	/	/	/	108	42	110	12	37	160	15	315	315	260	415	300	212	20	80	65	640
180M	2-4	279	241	/	/	/	121	48	110	14	42.5	180	15	350	360	280	455	310	240	22	105	70	690
180L	4-8	279	279	/	/	/	121	48	110	14	42.5	180	15	350	360	280	455	350	240	22	105	70	730
200L	2-8	318	305	/	/	/	133	55	110	16	49	200	19	390	400	305	505	370	185	25	85	70	760
225S	4-8	356	286	/	/	/	149	60	140	18	53	225	19	435	450	335	550	370	195	28	110	75	810
225M	2	356	311	/	/	/	149	55	110	16	49	225	19	435	450	335	550	395	195	28	110	75	805
	4-8	356	311	/	/	/	149	60	140	18	53	225	19	435	450	335	550	395	195	28	110	75	835
250M	2	406	349	/	/	/	168	60	140	18	53	250	24	485	490	365	620	445	215	30	120	80	910
	4-8	406	349	/	/	/	168	65	140	18	58	250	24	485	490	365	620	445	215	30	120	80	910
280S	2	457	368	/	/	/	190	65	140	18	58	280	24	545	550	400	675	490	215	35	140	85	985
	4-8	457	368	/	/	/	190	75	140	20	67.5	280	24	545	550	400	675	490	215	35	140	85	985
280M	2	457	419	/	/	/	190	65	140	18	58	280	24	545	550	400	675	540	215	35	140	85	1035
	4-8	457	419	/	/	/	190	75	140	20	67.5	280	24	545	550	400	675	540	215	35	140	85	1035
315S	2	508	406	/	/	/	216	65	140	18	58	315	28	630	625	555	865	570	250	49	110	120	1190
	4-8	508	406	/	/	/	216	80	170	22	71	315	28	630	625	555	865	570	250	49	110	120	1220
315M/L	2	508	457	508	/	/	216	65	140	18	58	315	28	630	625	555	865	680	250	49	110	120	1300
	4-8	508	457	508	/	/	216	80	170	22	71	315	28	630	625	555	865	680	250	49	110	120	1330
355M/L	2	610	500	560	630	/	254	100	210	20	67.5	355	28	730	710	/	1010	750	330	52	/	120	1525
	4-8	610	500	560	630	/	254	95	170	25	86	355	28	730	710	/	1010	750	330	52	/	120	1565
400M/L	2	686	710	800	900	/	280	80	170	22	71	400	35	810	810	/	1075	1250	360	45	/	120	2050
	4-8	686	710	800	900	/	280	110	210	28	71	400	35	810	810	/	1075	1250	360	45	/	120	2090

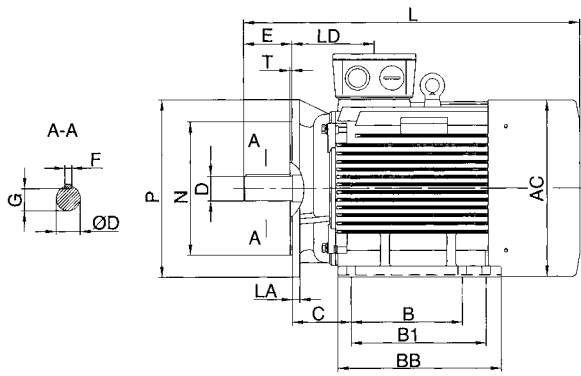

80-400

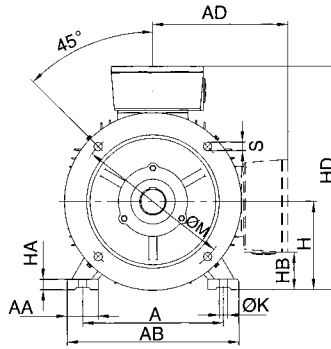

80-200

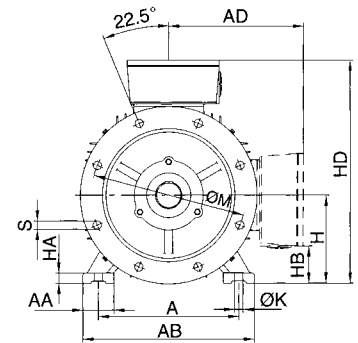

225-400

◆ B35

Frame size	Pole	Mounting dimensions (mm)																		Overall dimensions (mm)				
		A	B	B1	B2	B3	C	D	E	F	G	H	K	M	N	P	R	S	T	AB	AC	AD	HD	L
80M	2-6	125	100	/	/	/	50	19	40	6	15.5	80	10	165	130	200	0	4-ø12	4	160	160	145	225	280
90S	2-6	140	100	/	/	/	56	24	50	8	20	90	10	165	130	200	0	4-ø12	4	180	175	155	245	315
90L	2-6	140	125	/	/	/	56	24	50	8	20	90	10	165	130	250	0	4-ø12	4	180	175	155	245	340
100L	2-6	160	140	/	/	/	63	28	60	8	24	100	12	215	180	250	0	4-ø15	4	200	200	180	270	375
112M	2-6	190	140	/	/	/	70	28	60	8	24	112	12	215	180	250	0	4-ø15	4	230	225	190	305	400
132S	2-6	216	140	/	/	/	89	38	80	10	33	132	12	265	230	300	0	4-ø15	4	265	260	210	345	465
132M	2-6	216	178	/	/	/	89	38	80	10	33	132	12	265	230	300	0	4-ø15	4	265	260	210	345	505
160M	2-8	254	210	/	/	/	108	42	110	12	37	160	15	300	250	350	0	4-ø19	5	315	315	260	415	600
160L	2-8	254	254	/	/	/	108	42	110	12	37	160	15	300	250	350	0	4-ø19	5	315	315	260	415	640
180M	2-4	279	241	/	/	/	121	48	110	14	42.5	180	15	300	250	350	0	4-ø19	5	350	360	280	455	690
180L	4-8	279	279	/	/	/	121	48	110	14	42.5	180	15	300	250	350	0	4-ø19	5	350	360	280	455	730
200L	2-8	318	305	/	/	/	133	55	110	16	49	200	19	350	300	400	0	4-ø19	5	390	400	305	505	760
225S	4-8	356	286	/	/	/	149	60	140	18	53	225	19	400	350	450	0	8-ø19	5	435	450	335	550	810
225M	2	356	311	/	/	/	149	55	110	16	49	225	19	400	350	450	0	8-ø19	5	435	450	335	550	805
	4-8	356	311	/	/	/	149	60	140	18	53	225	19	400	350	450	0	8-ø19	5	435	450	335	550	835
250M	2	406	349	/	/	/	168	60	140	18	53	250	24	500	450	550	0	8-ø19	5	485	490	365	620	910
	4-8	406	349	/	/	/	168	65	140	18	58	250	24	500	450	550	0	8-ø19	5	485	490	365	620	910
280S	2	457	368	/	/	/	190	65	140	18	58	280	24	500	450	550	0	8-ø19	5	545	550	400	675	985
	4-8	457	368	/	/	/	190	75	140	20	67.5	280	24	500	450	550	0	8-ø19	5	545	550	400	675	985
280M	2	457	419	/	/	/	190	65	140	18	58	280	24	500	450	550	0	8-ø19	5	545	550	400	675	1035
	4-8	457	419	/	/	/	190	75	140	20	67.5	280	24	500	450	550	0	8-ø19	5	545	550	400	675	1035
315S	2	508	406	/	/	/	216	65	140	18	58	315	28	600	550	660	0	8-ø24	6	630	625	555	865	1190
	4-8	508	406	/	/	/	216	80	170	22	71	315	28	600	550	660	0	8-ø24	6	630	625	555	865	1220
315M/L	2	508	457	508	/	/	216	65	140	18	58	315	28	600	550	660	0	8-ø24	6	630	625	555	865	1300
	4-8	508	457	508	/	/	216	80	170	22	71	315	28	600	550	660	0	8-ø24	6	630	625	555	865	1330
355M/L	2	610	500	560	/	/	254	75	140	20	67.5	355	28	740	680	800	0	8-ø24	6	730	710	/	1010	1525
	4-8	610	500	560	/	/	254	100	210	25	86	355	28	740	680	800	0	8-ø24	6	730	710	/	1010	1565
400M/L	2	686	710	800	900	/	280	80	170	22	71	400	35	940	880	1000	0	8-ø28	6	810	810	/	1075	2050
	4-8	686	710	800	900	/	280	110	210	28	100	400	35	940	880	1000	0	8-ø28	6	810	810	/	1075	2090

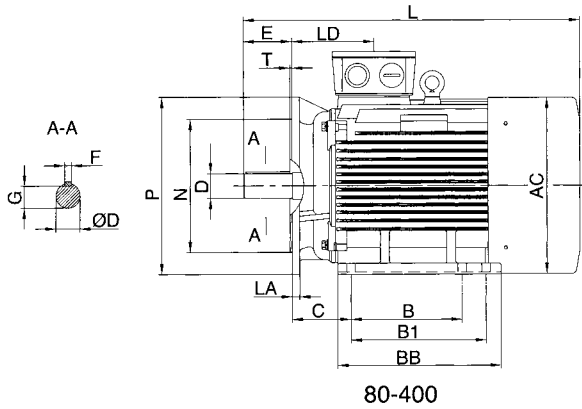

80-400

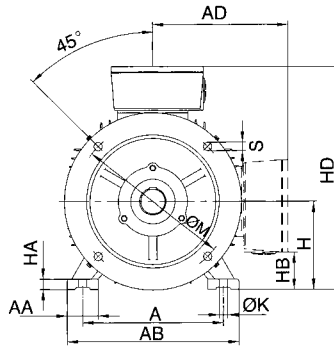

80-200

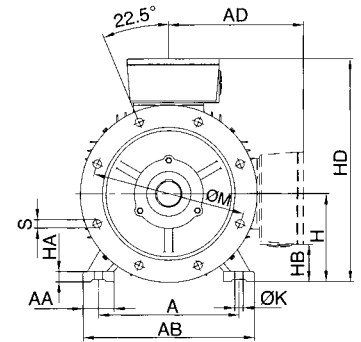

225-400

◆ B5

Frame size	Pole	Mounting dimensions (mm)											Overall dimensions (mm)		
		D	E	F	G	H	M	N	P	R	S	T	AC	HD	L
80M	2-6	19	40	6	15.5	80	165	130	200	0	4-Ø12	4	160	245	280
90S	2-6	24	50	8	20	90	165	130	200	0	4-Ø12	4	175	255	315
90L	2-6	24	50	8	20	90	165	130	200	0	4-Ø12	4	175	255	340
100L	2-6	28	60	8	24	100	215	180	250	0	4-Ø15	4	200	290	375
112M	2-6	28	60	8	24	112	215	180	250	0	4-Ø15	4	225	310	400
132S	2-6	38	80	10	33	132	265	230	300	0	4-Ø15	4	260	365	465
132M	2-6	38	80	10	33	132	265	230	300	0	4-Ø15	4	260	365	505
160M	2-8	42	110	12	37	160	300	250	350	0	4-Ø19	5	315	425	600
160L	2-8	42	110	12	37	160	300	250	350	0	4-Ø19	5	315	425	640
180M	2-4	48	110	14	42.5	180	300	250	350	0	4-Ø19	5	360	450	690
180L	4-8	48	110	14	42.5	180	300	250	350	0	4-Ø19	5	360	450	730
200L	2-8	55	110	16	49	200	350	300	400	0	4-Ø19	5	400	505	760
225S	4-8	60	140	18	53	225	400	350	450	0	8-Ø19	5	450	550	810
225M	2	55	110	16	49	225	400	350	450	0	8-Ø19	5	450	550	805
	4-8	60	140	18	53	225	400	350	450	0	8-Ø19	5	450	550	835
250M	2	60	140	18	53	250	500	450	550	0	8-Ø19	5	490	645	910
	4-8	65	140	18	58	250	500	450	550	0	8-Ø19	5	490	645	910
280S	2	65	140	18	58	280	500	450	550	0	8-Ø19	5	550	665	985
	4-8	65	140	20	67.5	280	500	450	550	0	8-Ø19	5	550	665	985
280M	2	65	140	18	58	280	500	450	550	0	8-Ø19	5	550	665	1035
	4-8	75	140	20	67.5	280	500	450	550	0	8-Ø19	5	550	665	1035

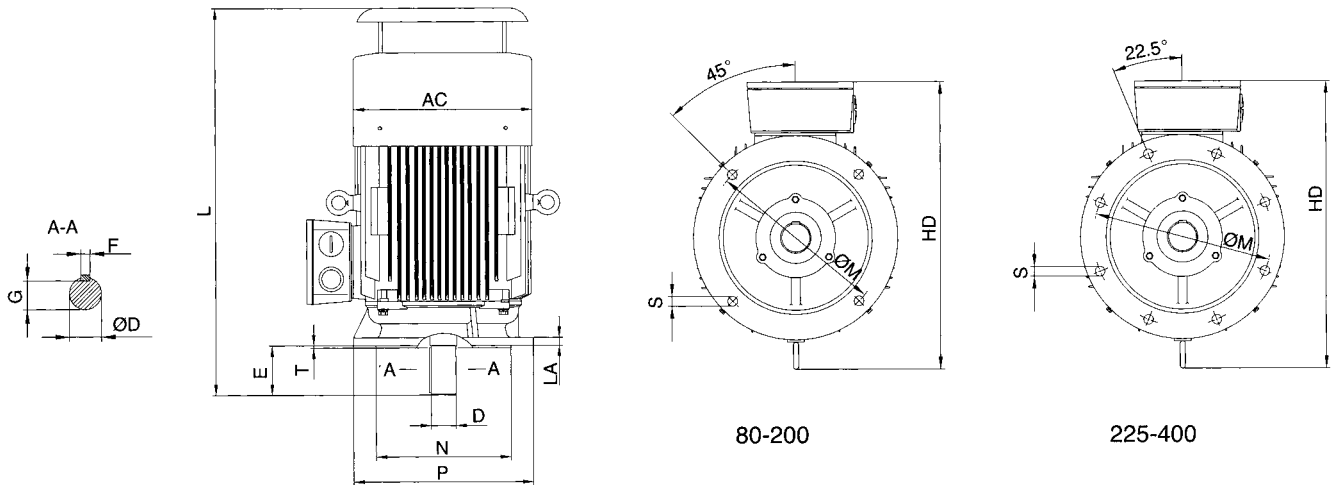

◆ V1

Frame size	Pole	Mounting dimensions (mm)											Overall dimensions (mm)		
		D	E	F	G	H	M	N	P	R	S	T	AC	HD	L
80M	2-6	19	40	6	15.5	80	165	130	200	0	4-ø12	4	160	245	305
90S	2-6	24	50	8	20	90	165	130	200	0	4-ø12	4	175	255	345
90L	2-6	24	50	8	20	90	165	130	200	0	4-ø12	4	175	255	370
100L	2-6	28	60	8	24	100	215	180	250	0	4-ø15	4	200	290	410
112M	2-6	28	60	8	24	112	215	180	250	0	4-ø15	4	225	310	450
132S	2-6	38	80	10	33	132	265	230	300	0	4-ø15	4	260	365	510
132M	2-6	38	80	10	33	132	265	230	300	0	4-ø15	4	260	365	550
160M	2-8	42	110	12	37	160	300	250	350	0	4-ø19	5	315	435	650
160L	2-8	42	110	12	37	160	300	250	350	0	4-ø19	5	315	435	690
180M	2-4	48	110	14	42.5	180	300	250	350	0	4-ø19	5	360	515	750
180L	4-8	48	110	14	42.5	180	300	250	350	0	4-ø19	5	360	515	790
200L	2-8	55	110	16	49	200	350	300	400	0	4-ø19	5	400	560	840
225S	4-8	60	140	18	53	225	400	350	450	0	8-ø19	5	450	610	905
225M	2	55	110	16	49	225	400	350	450	0	8-ø19	5	450	610	910
	4-8	60	140	18	53	225	400	350	450	0	8-ø19	5	450	610	935
250M	2	60	140	18	53	250	500	450	550	0	8-ø19	5	490	690	995
	4-8	65	140	18	53	250	500	450	550	0	8-ø19	5	490	690	995
280S	2	65	140	18	53	280	500	450	550	0	8-ø19	5	550	750	1070
	4-8	75	140	20	67.5	280	500	450	550	0	8-ø19	5	550	750	1070
280M	2	65	140	18	58	280	500	450	550	0	8-ø19	5	550	750	1120
	4-8	75	140	20	67.5	280	500	450	550	0	8-ø19	5	550	750	1120
315S	2	65	140	18	58	315	600	550	660	0	8-ø24	6	625	985	1340
	4-8	80	170	22	71	315	600	550	660	0	8-ø24	6	625	985	1370
315M/L	2	65	140	18	58	315	600	550	660	0	8-ø24	6	625	985	1450
	4-8	80	170	22	71	315	600	550	660	0	8-ø24	6	625	985	1480
355M/L	2	75	140	20	67.5	355	740	680	800	0	8-ø24	6	710	1145	1665
	4-8	100	210	25	86	355	740	680	800	0	8-ø24	6	710	1145	1700
400M/L	2	80	170	22	71	400	940	880	1000	0	8-ø28	6	810	1245	2150
	4-8	110	210	28	100	400	940	880	1000	0	8-ø28	6	810	1245	2180

## CUSCINETTI BEARINGS

B3 B35 B5				
Frame size	Driving End		Non-driving End	
	2 (pole)	4/6/8 (pole)	2 (pole)	4/6/8 (pole)
80	6204ZZ	6204ZZ	6204ZZ	6204ZZ
90	6205ZZ/C3	6205ZZ/C3	6205ZZ/C3	6205ZZ/C3
100	6206ZZ/C3	6206ZZ/C3	6206ZZ/C3	6206ZZ/C3
112	6306ZZ/C3	6306ZZ/C3	6306ZZ/C3	6306ZZ/C3
132	6308ZZ/C3	6308ZZ/C3	6308ZZ/C3	6308ZZ/C3
160	6309ZZ/C3	6309ZZ/C3	6309ZZ/C3	6309ZZ/C3
180	6311ZZ/C3	6311ZZ/C3	6311ZZ/C3	6311ZZ/C3
200	6312ZZ/C3	6312ZZ/C3	6312ZZ/C3	6312ZZ/C3
225	6313ZZ/C3	6313ZZ/C3	6313ZZ/C3	6313ZZ/C3
250	6314ZZ/C3	6314ZZ/C3	6314ZZ/C3	6314ZZ/C3
280	6314C3	6317C3	6314C3	6317C3
315	6317C3	6319C3(NU319)	6317C3	6319C3
355	6319C3	6322C3(NU322)	6319C3	6320C3
400	6317C3	6326C3(NU326)	6317C3	6326C3

V1				
Frame size	Driving End		Non-driving End	
	2 (pole)	4/6/8 (pole)	2 (pole)	4/6/8 (pole)
315	6317C3	6319C3(NU319)	7317	7319
355	6319C3	6322C3(NU322)	7317	7320
400	6317C3	6326C3(NU326)	7317	7326

## VIBRAZIONI VIBRATION

Frame size	≤132		>132~225		>225~400	
	600~1800	>1800~3600	600~1800	>1800~3600	500~1800	>1800~3600
Synchronous Speed r/min						
Vibration Class	Effective Value of speed mm/s					
N	1.8		2.8		3.5	
R	0.71	1.12	1.12	1.80	1.80	2.80
S	0.45	0.71	0.71	1.12	1.12	1.80

RUMOROSITÀ  
NOISE

Output (kW)	Synchronous Speed r/min			
	3000	1500	1000	750
	Lp dB(A) Sound perssure level in dB(A)			
	no load	no load	no load	no load
0.55	/	46	44	/
0.75	52	46	45	/
1.1	52	47	45	/
1.5	54	47	47	/
2.2	54	49	48	/
3	56	49	52	/
4	58	51	53	/
5.5	62	52	53	52
7.5	62	52	58	52
11	73	56	58	54
15	73	56	59	56
18.5	73	57	62	58
22	77	59	62	58
30	78	62	63	60
37	78	65	64	62
45	79	65	66	62
55	80	68	66	63
75	81	72	68	63
90	81	72	68	63
110	82	74	68	63
132	82	74	68	67
160	83	75	69	67
200	83	75	70	67
250	85	78	70	67
315	85	78	73	70
355	85	78	73	70
400	88	80	73	71
450	88	80	73	71
500	88	82	73	/
560	88	82	/	/
630	88	82	/	/