

cemp

Flameproof
Motors

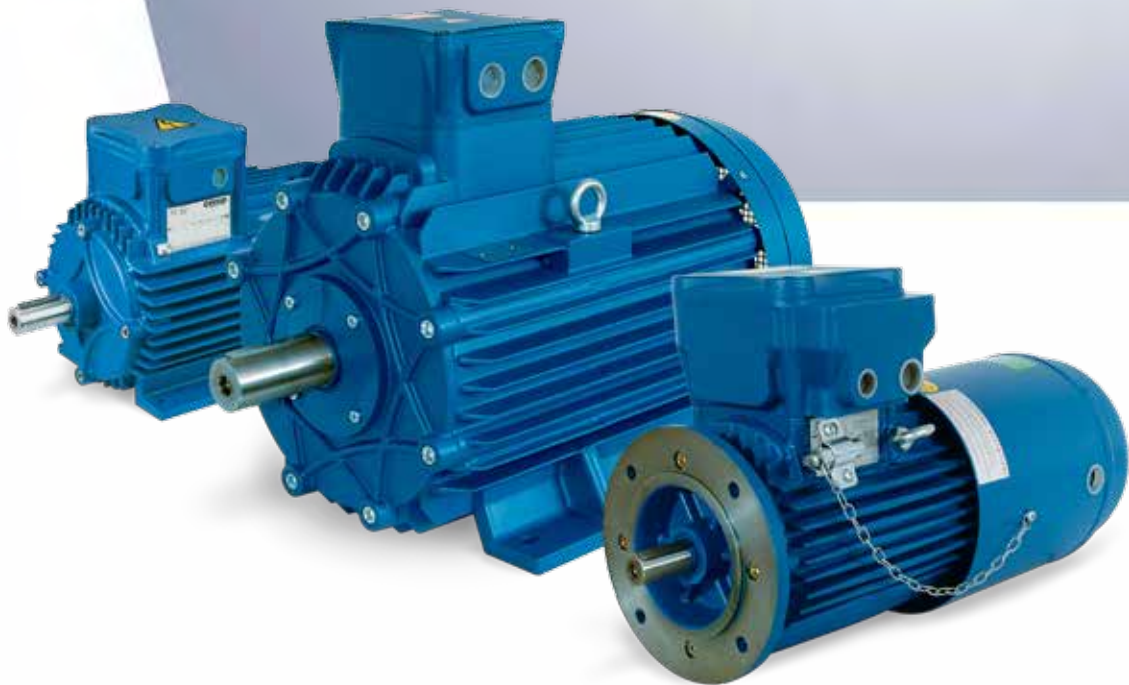

Electric Motors

A Regal Brand

REGAL

cemp

Flameproof
Motors

A Regal Brand

REGAL

Electric motors

Flameproof
Flameproof with brake
Flameproof for mines
Non sparking
Dust proof
Gas + Dust

Frame size 63 ÷ 315

	Pagina
0. Introduzione	8
0.1 Unità di misura del SI ed equivalenze	8
0.2 Formule di comune utilizzo	9
0.3 Norme e specifiche	10
0.4 Protezione contro le esplosioni nelle zone pericolose	11
1. Informazioni generali	16
1.1 Gamma motori	16
1.2 Caratteristiche principali comuni	18
1.3 Principali opzioni	18
1.4 Identificazione della sigla	19
2. Caratteristiche meccaniche	20
2.1 Installazione ed applicazioni	20
2.2 Versione per le basse temperature e per la prevenzione della condensa	20
2.3 Materiali, verniciatura e targa	21
2.4 Sporgenze d'albero, bilanciatura, vibrazioni, rumorosità e accoppiamento	23
2.5 Freno dei motori	23
2.6 Cuscinetti	25
2.7 Carichi radiali ammissibili sull'albero con cuscinetti standard	27
2.8 Carico assiale limite sull'albero con cuscinetti standard	28
2.9 Scatola morsettieria	29
2.10 Posizione della scatola morsettieria e morsetti	30
2.11 Entrate cavi	30

	Pagina
3. Caratteristiche elettriche	31
3.1 Condizioni nominali di esercizio	31
3.2 Rendimento e fattore di potenza a carico parziale	32
3.3 Isolamento e sovratemperatura	32
3.4 Tipo di servizio	33
3.5 Schemi di collegamento	35
3.6 Schemi di collegamento freno	36
3.7 Avviamenti orari consentiti (Frenate per ora)	36
3.8 Marcatura dei morsetti ausiliari	37
3.9 Sistemi di protezione	37
3.10 Motori azionati da variatore elettronico di frequenza	38
4. Dati nominali	167
4.1 Motori trifase, 1 velocità	168
4.2 Motori trifase, 1 velocità IE2	172
4.3 Motori trifase, 2 velocità, (coppia costante)	175
4.4 Motori trifase, 2 velocità, (coppia quadratica)	179
4.5 Motori monofase, 1 velocità	183
4.6 Motori trifase con freno, 1 o 2 velocità	184
4.7 Motori alimentati da inverter	188
5. Dimensioni d'ingombro e forme costruttive	195
5.1 Forme costruttive	196
5.2 Dimensioni d'ingombro motori standard e per miniera	198
5.3 Dimensioni d'ingombro motori con freno	202
6. Parti di ricambio	209

ENGLISH **CONTENTS**

	Page
0. Introduction	40
0.1 SI units and conversion equations	40
0.2 Engineering formulae for motor drives	41
0.3 Standards and specifications	42
0.4 Protection against explosions in dangerous areas	43
1. General informations	48
1.1 Range of motors	48
1.2 Common main characteristics	50
1.3 Main options	50
1.4 Nomenclature	51
2. Design features	52
2.1 Installation and applications	52
2.2 Low temperature version and anti-condensation heating	52
2.3 Materials, painting and nameplate	53
2.4 Shaft ends, balancing, vibrations, noise level coupling and belt drives	55
2.5 Brake motors	55
2.6 Bearing system	57
2.7 Permissible radial loads on the shaft with standard bearings	59
2.8 Permissible axial load on the shaft with standard bearings	60
2.9 Terminal box	61
2.10 Position of terminal box and terminals	62
2.11 Cable-entries	62

	Page
3. Electrical design	63
3.1 Standard operating conditions	63
3.2 Efficiency and power factor at partial load	64
3.3 Insulation and temperature rise	64
3.4 Duty types	65
3.5 Connecting diagrams	67
3.6 Brake connection diagrams	68
3.7 Hourly start-ups allowed (Braking: n° per hour)	68
3.8 Additional terminals marking	69
3.9 Protection devices	69
3.10 Frequency converter driven motors	70
4. Performance data	167
4.1 Three-phase motors, 1 speed	168
4.2 Three-phase motors, 1 speed IE2	172
4.3 Three-phase motors, 2 speeds, (constant torque)	175
4.4 Three-phase motors, 2 speeds, (quadratic torque)	179
4.5 Single-phase motors, 1 speed	183
4.6 Three-phase motors with brake, 1 or 2 speeds	184
4.7 Motors energized by inverter	188
5. Overall dimensions and mounting arrangements	195
5.1 Mounting arrangements	196
5.2 Overall dimensions of standard and mining version motors	198
5.3 Overall dimensions of motors with brakes	202
6. Spare parts	209

FRANÇAIS **SOMMAIRE**

	Page
0. Introduction	72
0.1 Unités de mesure du SI et équivalences	72
0.2 Formules d'usage commun	73
0.3 Normes et spécifications	74
0.4 Protection contre les explosions dans les zones dangereuses	75
1. Informations générales	80
1.1 Gamme de moteurs	80
1.2 Principales caractéristiques communes	82
1.3 Options principales	82
1.4 Identification de la référence commerciale	83
2. Caractéristiques mécaniques	84
2.1 Installation et applications	84
2.2 Version pour basses températures et pour la prévention de la condensation	84
2.3 Matériaux, peinture et plaque signalétique	85
2.4 Bout d'arbre, équilibrage, vibrations, bruit et accouplement	87
2.5 Frein des moteurs	87
2.6 Roulements	89
2.7 Charges radiales admissibles sur l'arbre avec roulements standards	81
2.8 Charge axiale limite sur l'arbre avec roulements standards	92
2.9 Boîte à bornes	93
2.10 Position de la boîte à bornes et des bornes	94
2.11 Entrées de câbles	94

	Page
3. Caractéristiques électriques	95
3.1 Conditions nominales d'exploitation	95
3.2 Rendement et facteur de puissance à différentes charges	96
3.3 Isolation et température d'échauffement	96
3.4 Différents régimes d'utilisation	97
3.5 Schémas de branchement	99
3.6 Schémas de raccordement du frein	100
3.7 Démarrages horaires autorisés (Freinages par heure)	100
3.8 Identification des bornes pour les accessoires	101
3.9 Systèmes de protection	101
3.10 Moteurs alimentés par un variateur électronique de fréquence	102
4. Données nominales	167
4.1 Moteurs triphasés, 1 vitesse	168
4.2 Moteurs triphasés, 1 vitesse IE2	172
4.3 Moteurs triphasés, 2 vitesses, (couple constant)	175
4.4 Moteurs triphasés, 2 vitesses, (couple quadratique)	179
4.5 Moteurs monophasés, 1 vitesse	183
4.6 Moteurs triphasés avec frein, 1 ou 2 vitesses	184
4.7 Moteurs alimentés par variateur	188
5. Dimensions et formes de construction	195
5.1 Formes de construction	196
5.2 Dimensions d'encombrement des moteurs standard et pour mine ..	198
5.3 Dimensions d'encombrement des moteurs à frein	202
6. Pièces détachées	209

Electric motors

0. Introduction

0.1 SI units and conversion equations

Table 0A

Description	SI			Conversion equations
	Formular symbols	Unit symbol	Unit name	
Distance Area Volume	L A V	m m^2 m^3	metre	$1\text{ m}^3 = 1000\text{ dm}^3$ $1\text{ dm}^3 = 1\text{ l}$
Angle in one plane	α, β, γ	rad	radian	$1^\circ = \frac{\pi}{180}\text{ rad}$ $1' = 1^\circ/60$ $1'' = 1'/60$
Time Frequency	t f	s Hz	second Hertz	$1\text{ Hz} = 1/\text{s}$
Speed Velocity Angular velocity	n v ω	1/min m/s rad/s		$1\text{ km/h} = \frac{1}{3.6}\text{ m/s}$
Acceleration Angular acceleration	a α	m/s^2 rad/s^2		
Mass Density	m ρ	kg kg/m^3	kilogram	
Force Pressure Mechanical stress	F p σ	N $\text{Pa} = \text{N/m}^2$ N/mm^2	Newton Pascal	$1\text{ N} = 1\text{ kg} \cdot 1\text{ m/s}^2$ $9.81\text{ N} = 1\text{ kgf}$ $9.81 \cdot 10^4\text{ N/m}^2 = 1\text{ kgf/cm}^2$ $9.81\text{ N/mm}^2 = 1\text{ kgf/mm}^2$
Work done Energy Thermal quantity	W W Q	$J = Nm$	Joule	$9.81\text{ Nm} = 1\text{ kgfm}$ $4187\text{ J} = 1\text{ kcal}$ $1\text{ kWh} = 3.6 \times 10^6\text{ J}$
Torque	M	Nm		$9.81\text{ Nm} = 1\text{ kgfm}$ $1\text{ Nm} = 0.102\text{ kgfm}$
Power	P	$W = \text{J/s} = \text{Nm/s}$	Watt	$735.5\text{ W} = 1\text{ hp}$
Moment of inertia	J	kg m^2		$9.81\text{ kg m}^2 = 1\text{ kpms}^2$ $\text{PD2} = 4\text{ J}$
Dynamic viscosity Kinematic viscosity	η ν	$\text{Pa} \cdot \text{s}$ m^2/s		$10^{-1}\text{ Pa} \cdot \text{s} = 1\text{ P (Poise)}$ $10^{-4}\text{ m}^2/\text{s} = 1\text{ St (Stokes)}$
Electric current Electric voltage Electric resistance Electric conductivity Electric capacity Charge	I U R G C Q	A V Ω S F C	Ampere Volt Ohm Siemens Faraday Coulomb	$1\text{ A} = 1\text{ W/V} = 1\text{ V}/\Omega$ $1\text{ V} = 1\text{ W/A}$ $1\ \Omega = 1\text{ V/A} = 1/\text{S}$ $1\text{ S} = 1/\Omega$ $1\text{ F} = 1\text{ C/V}$ $1\text{ C} = 1\text{ A} \cdot \text{s}$
Inductance Magnetic flux density Magnetic field strength Magnetic flux	L B H Φ	H T A/m Wb	Henry Tesla Weber	$1\text{ H} = 1\text{ Vs/A}$ $1\text{ T} = 1\text{ Wb/m}^2$ $1\text{ Wb} = 1\text{ V} \cdot \text{s}$
Temperature difference	T ϑ	K $^\circ\text{C}$	Kelvin	$0\text{ K} = -273.15\text{ }^\circ\text{C}$

0. Introduction

0.2 Engineering formulae for motor drives

Power (3-phase motors)

$$P_1 = \text{power input} = \frac{U \cdot I \cdot \cos \varphi \cdot \sqrt{3} \cdot 10^{-3}}{1} \text{ [kW]}$$
$$P_2 = \text{power output} = P_1 \cdot \eta \text{ [kW]}$$

Where:

$$U = \text{voltage [V]}$$
$$I = \text{current [A]}$$
$$\cos \varphi = \text{power factor}$$
$$\eta = \text{efficiency}$$

Power requirements of some applications

Lifting:

$$P = \frac{m \cdot v}{\eta} \cdot 9.81 \cdot 10^{-3} \text{ [kW]}$$

Rotation:

$$P = \frac{M \cdot n}{9550 \cdot \eta} \text{ [kW]}$$

Fan and pump drives:

$$P = \frac{H \cdot Q}{\eta} \text{ [W]}$$

Where:

$$P = \text{power [kW]}$$
$$m = \text{mass [kg]}$$
$$v = \text{speed [m/s]}$$
$$n = \text{rotational speed [min}^{-1}\text{]}$$
$$\eta = \text{efficiency}$$
$$M = \text{torque [Nm]}$$
$$Q = \text{output [m}^3\text{/s]}$$
$$H = \text{head [N/m}^2\text{]}$$

Torque from motor power

$$M = 9550 \cdot \frac{P_2}{n} \text{ [Nm]}$$

Where:

$$P_2 = \text{motor output [kW]}$$
$$n = \text{motor speed}$$

Conversion of torque for step-up and step-down speed ratios:

$$M_2 = \frac{M_1 \cdot n_1}{n_2}$$

Where:

$$n_1 = \text{motor speed [min}^{-1}\text{]}$$
$$M_1 = \text{motor torque at } n_1 \text{ [Nm]}$$
$$n_2 = \text{speed of load [min}^{-1}\text{]}$$
$$M_2 = \text{torque of load at } n_2 \text{ [Nm]}$$

Moment of Inertia J

Moment of Inertia of a cylindrical flywheel:

$$J = \frac{md^2}{8}$$

Where:

$$m = \text{mass [kg]}$$
$$d = \text{flywheel diameter [m]}$$

Effective moment of inertia on the motor of a linearly moved load:

$$J = 91.2 \cdot m \cdot \left(\frac{v}{n}\right)^2$$

Where:

$$m = \text{mass [kg]}$$
$$v = \text{velocity [m/s]}$$
$$n = \text{motor speed [min}^{-1}\text{]}$$

Conversions of moments of inertia for step-up or step-down speed ratio:

$$J_2 = J_1 \cdot \left(\frac{n_1}{n_2}\right)^2$$

Where:

$$n_1 = \text{motor speed}$$
$$J_1 = \text{moment of inertia at } n_1$$
$$n_2 = \text{speed of load}$$
$$J_2 = \text{moment of inertia of load}$$

Factor of Inertia FI

$$FI = \frac{J_{\text{mot}} + J_{\text{load}}}{J_{\text{mot}}}$$

Where:

$$J_{\text{mot}} = \text{moment of inertia of motor}$$
$$J_{\text{load}} = \text{moment of inertia of load}$$

Starting time t_a

$$t_a = \frac{FI \cdot J_{\text{mot}} \cdot n}{9.55 \cdot (M_{\text{mot}} - M_{\text{load}})} \text{ [s]}$$

Where:

$$FI = \text{Factor of inertia}$$
$$J_{\text{mot}} = \text{moment of inertia of motor [kgm}^2\text{]}$$
$$n = \text{motor speed [min}^{-1}\text{]}$$
$$M_{\text{mot}} = \text{motor torque during starting (mean) [Nm]}$$
$$M_{\text{load}} = \text{counter torque of load during starting (mean) [Nm]}$$

Speed

The no-load speed is virtually the same as the synchronous speed. The synchronous speed of the motor is calculated as follow:

$$n_s = 120 \cdot f/p \text{ [min}^{-1}\text{]}$$

Where:

$$f = \text{frequency [Hz]}$$
$$p = \text{number of pole}$$

The synchronous speed is reduced by the slip (S) to the rated speed:

$$n_n = n_s \cdot (1-S) \text{ [min}^{-1}\text{]}$$

0. Introduction

0.3 Standards and specifications

Flameproof motors conform to the following standards and specifications:

Table 0B

Title	INTERNATIONAL	EU
	IEC	CENELEC
Electrical rotating machines/rated operation and characteristic data	IEC 60034-1	EN 60034-1
Methods for determining losses and efficiency of rotating electrical machines	IEC 60034-2	EN 60034-2
Protection types rotating electrical machines	IEC 60034-5	EN 60034-5
Cooling methods of rotating electrical machines	IEC 60034-6	EN 60034-6
Construction types of rotating electrical machines	IEC 60034-7	EN 60034-7
Terminal markings and direction of rotation for electrical machines	IEC 60034-8	EN 60034-8
Noise emission, limit values	IEC 60034-9	EN 60034-9
Start-up behaviour of squirrel-cage motors at 50 Hz up to 660V	IEC 60034-12	EN 60034-12
Vibration severity of rotating electrical machines	IEC 60034-14	EN 60034-14
Protection level provided by enclosures for electrical equipment against mechanical impact (Code IK)	IEC 60068-1 IEC 60068-2-75	EN 60068-1 EN 60068-2-75
Fixing dimensions and outputs for IM B3	IEC 60072	EN 60072
Fixing dimensions and outputs for IM B5, IM B14	IEC 60072	EN 60072
Cylindrical shaft ends for electrical machines	IEC 60072	EN 60072
Electrical equipment for hazardous areas General provisions	IEC 60079-0	EN 60079-0
Electrical equipment for hazardous areas Flame-proof enclosure "d"	IEC 60079-1	EN 60079-1
Electrical equipment for hazardous areas Increased safety "e"	IEC 60079-7	EN 60079-7
Equipment with protection type "t" for use in the presence of flammable dusts	IEC 60079-31	EN 60079-31

0. Introduction

0.4 Protection against explosions in dangerous areas

0.4.1 Types protection

The use of an electrical apparatus in potentially explosive atmospheres is quite usual today.

This equipment has to be manufactured in such a way that there is no risk of explosion.

An explosion occurs when of the three following conditions happen:

- presence of a potentially explosive atmosphere;
- possibility of transmission of the explosion;
- existence of an ignition source.

The recognized types of protection eliminate one of these conditions and thus make an explosion impossible.



Fig. 0A - Specific marking for protection against explosions - Directive 94/9/EC.

Protection methods for GAS

Two types of protection prevent the presence of a potentially explosive atmosphere inside the electrical apparatus:

- oil immersion (safety “o”);
- pressurized apparatus (safety “p”).

Two types of protection make the transmission of an internal explosion to the potentially explosive atmosphere surrounding the electrical apparatus impossible:

- sand filling (safety “q”);
- flameproof enclosure (safety “d”).

Lastly, three types of protection eliminate any source of ignition, such as sparks, overheating, etc...:

- increased safety (safety “e”);
- intrinsic safety (safety “i”);
- protection “n” (restricted to zone 2).

Protection method for flammable dusts

For flammable dusts, only one method of protection is provided for:

- housing which prevents the infiltration of dust and surface temperature limitation (protection type “t”).

In practice only five of these eight methods of protection are applicable to the electric motor:

- pressurized apparatus (symbol Ex p);
- flameproof enclosure (symbol Ex d);
- increased safety (symbol Ex e);
- non sparking protection (symbol Ex n);
- protection by a housing (symbol Ex t).

Electric motors have another method of protection for gas (symbol Ex de) which is a combination of:

- flameproof enclosure “d” for motor frame;
- increased safety “e” for terminal box.

0.4.2 Dangerous areas and zones

Dangerous areas include any area in which explosive atmospheres may occur under specific conditions.

An explosive atmosphere is a mixture of air and combustible gases, vapours, fumes or dust under atmospheric conditions where combustion expands itself (explosion) after ignition.

Only local authorities can classify hazardous areas.

The users shall classify the hazardous areas as indicated in the European directive 1999/92/EC under their own responsibility.

International standards IEC 61241-10 provide instructions on how to classify the hazardous areas in relation to the chemical nature, to the physical characteristics and to the amount of substances used and based on the frequency and period of time in which an explosive mix may develop.



Fig. 0B - Warning sign for areas subject to the risk of explosion - Directive 99/92/EC

Zones susceptible to gas

When the hazard is due to the presence of gas, vapours or mists of flammable substances, the European directive 1999/92/EC envisages a classification in three zones defined as follows:

Zone 0 - Areas constantly susceptible to an explosive atmosphere, or for long periods of time. Power equipment with double insulation must be installed in this area.

Zone 1 - Areas where an explosive atmosphere is likely to develop during normal conditions. Flameproof electric motors or motors with added protection means can be installed in this zone (for the latter, restrictions by the standards apply).

Zone 2 - Areas rarely susceptible to an explosive atmosphere and for a short period of time.

Flameproof motors or motors with added protection can be installed in this zone, as well as non-sparking motors.

Zones susceptible to combustible dust

When the hazard is due to the presence of combustible dust, the European directive 1999/92/EC envisages a classification in three zones defined as follows:

Zone 20 - Areas constantly susceptible to an explosive atmosphere, or for long periods of time. Power apparatus cannot be installed in this zone.

Zone 21 - Areas where an explosive atmosphere is likely to develop during normal conditions. Electric motors certified in compliance with the ATEX directive with IP6x protection rating can be installed in this zone

Zone 22 - Areas rarely susceptible to an explosive atmosphere, and only for a short period of time. Depending on the type of dust also in zone 22 it may be necessary to have IP6x construction (see 0.4.4).

Table 0C - Dangerous areas classified into zones

Usage area in the presence of GAS	Usage area in the presence of COMBUSTIBLE DUSTS	Hazardous level of the operational ZONE
Zone 0	Zone 20	Explosive atmosphere ALWAYS PRESENT
Zone 1	Zone 21	PROBABLE explosive atmosphere
Zone 2	Zone 22	Explosive atmosphere UNLIKELY

0. Introduction

0.4.3 Apparatus classification

The ATEX 94/9/EC European Directive classifies equipment into three categories, with differing protection levels, related to the protection guaranteed.

NOTE: Equipment of higher categories can also be installed instead of those of a lower category.

Table 0D - Equipment categories

PROTECTION LEVEL guaranteed by the equipment Category	MINE	SURFACE	
	Category	GAS Category	COMBUSTIBLE DUST Category
Very high	M1	1G	1D
High	M2	2G	2D
Normal	not provided for	3G	3D

0.4.4 Enclosure groups

The standards classify electrical equipment into two groups.

Group I: electric apparatus to be installed in mines or galleries susceptible to firedamp or coal dust.

Group II: electric apparatus to be installed in surface plants susceptible to other explosive atmospheres.

The housings for equipment to be used at the surface in the presence of gas, with protection method "d" (explosion proof), are in turn subdivided into three sub-groups depending on the flammable substances for which they are suitable:

Group IIA, Group IIB, Group IIC.

A motor that belongs to a certain enclosure group is also suitable for lower enclosure groups: a motor in group IIB is also suitable for group IIA; a motor in group IIC is also suitable for group IIA and IIB.

The housings for equipment to be used in atmospheres containing flammable dust, with protection method "t", are separated into three sub-groups depending on the type of dust:

IIIA: flammable particles
 IIIB: non-conducting dust
 IIIC: conducting dust

Note: for the IIIC group and also for installation in zone 22 a minimum protection level of IP6x is necessary.

0.4.5 Temperature classes (for gas atmospheres)

The electrical apparatus is classified into 6 classes according to the maximum surface temperatures.

The maximum surface temperature is the highest temperature which is attained in service under the conditions described in the standards, by any part of the electrical apparatus, which, could ignite the surrounding atmosphere.

For electric motors this is:

- the temperature of the outside surface of the enclosure for "d" and "p" protection modes;
- the temperature of any internal or external point for type of protection "e" or "n".

Table 0E

Ignition temperature of medium relative to limit temperature [°C]	Temperature class	Maximum surface temperature of electrical equipment including 40°C ambient temperature	
		[°C]	[°F]
over 450	T 1	450	842
from 300 to 450	T 2	300	572
from 200 to 300	T 3	200	392
from 135 to 200	T 4	135	275
from 100 to 135	T 5	100	212
from 85 to 100	T 6	85	185

0. Introduction

0.4.6 Combustion temperatures of gases, vapours and groups

Combustible gases and vapours are divided into classes according to their ignition temperature and into groups according to their explosive capacity.

Markings on motors and other electrical equipment with the symbols used to indicate the protection mode, the enclosure group, and the temperature class, indicate the zone in which such equipment can be installed.

The indications contained in table 0F are shown only as an example.

Classification of the substances is not the responsibility of the supplier of the equipment.

Responsibility for the choice of equipment lies with the user.

Table 0F - Classification of the more common combustible gases and vapours according to temperature class and group

Group	Temperature classes					
	T 1	T 2	T 3	T 4	T 5	T 6
I	Methane (firedamp)					
IIA	Acetic acid Acetone Ammonia Benzole Benzene Carbonone Carbon monoxide Ethane Ethyl acetate Ethyl Chloride Methane Methanol Methyl acetate Methyl alcohol Methyl Chloride Naphtalene Propane Toluene Xylene	Acetic anhydride l amyl acetate n butane n butyl alcohol Amylic alcohol Butyl acetate Cyclohexanon Ethyl alcohol Iso butylic alcohol Liquefied gas Natural gas Propyl acetate	Cyclohexane Cyclohexanol Decane Diesel fuels Gasoline Heating oil Heptane Hexane Jet fuels Pentane Petroleum*	Acetaldehyde Ether		
IIB	Coke-oven gas Water gas (carburetted)	1,3- butadiene Ethylene Ethylbenzene Ethylene oxide	Hydrogen sulphide Isoprene Petroleum*	Ethyl ether		
IIC	Hydrogen	Acetylene				Carbon disulphide Ethyl nitrate

*depending on composition

0. Introduction

0.4.7 Temperature for atmospheres with combustible dusts

The flash point of the dust must be taken into account in providing protection against flammable dust, in both the cloud form and in layers.

The surface temperature of the enclosure indicated on the motor nameplate must be less than the reference ignition temperature. The reference temperature is the lowest between the two values thus calculated:

$TS1 = 2/3 T_{cl}$ (T_{cl} = ignition temperature of the cloud of dust)

$TS2 = T_{5mm} - 75K$ (T_{5mm} = ignition temperature of a 5mm layer of dust).

T_{amm} = lowest between $TS1$ and $TS2$.

Table 0G - Calculation of the flash points for combustible dusts

Dust ignition temperature	Cloud T_{cl}	Layer T_{5mm}
↓		
Safety temperature	$TS1 = 2/3 T_{cl}$	$TS2 = T_{5mm} - 75K$
↓		
Maximum surface temperature	$T_{amm} = \text{lowest between } TS1 \text{ and } TS2$	
↓		
Surface temperature of the motor $\leq T_{amm}$		

The surface temperature class is expressed as degrees Celsius, the manufacturer determines the temperature class depending on the thermal characteristics of its own product.

The temperature classes for the Cemp product are as follows:

$T150^{\circ}C$ - $T135^{\circ}C$ - $T125^{\circ}C$ - $T100^{\circ}C$ - $T85^{\circ}C$.

The indications contained in table 0H are given only by way of example.

Classification of the substances is not the responsibility of the supplier of the equipment.

Responsibility for the choice of equipment lies with the user.

Table 0H - Examples of flash points for combustible dusts

	Cloud [$^{\circ}C$]	Layer [$^{\circ}C$]
Aluminium	590	>450
Carbon dust	380	225
Flour	490	340
Wheat dust	510	300
Methylcellulose	420	320
Phenolic resin	530	>450
Polyethylene	420	melting
PVC	700	>450
Soot	810	570
Starch	460	435
Sugar	490	460

Source SIRA Ltd

0.4.8 Level of protection for the equipment (EPL, equipment protection level)

In accordance with standard IEC EN 60079-0 the marking of equipment to be used in a potentially explosive atmosphere must also have the suffix EPL.

EPL is defined as the level of protection assigned to electrical equipment based on the probability of it becoming a source of ignition.

The EPL also makes it possible to distinguish between the different explosive atmospheres.

The first letter makes the following distinctions:

M - for mining

G - for gas

D - for dust

The second letter gives information on the probability of becoming a source of ignition:

a - "very high" protection level (guarantees safety in normal operation, during foreseeable malfunctions and when subject to rare cases of malfunction);

b - "high" protection level (guarantees safety in normal operation and when subject to foreseeable malfunctions);

c - "increased" protection level (it is not a source of ignition during normal operation and has some additional protection measures to ensure that it remains an inactive source of ignition in events occurring regularly).

0. Introduction

0.4.9 Choice of safety-electric motor

The connection between danger zones and the categories of equipment to be used is defined in Directive 1999/92/EC.

The specific construction standards for the protection modes (e.g. Ex d) also define the motor category that can be obtained by applying the standards (e.g. 2G).

Table 0I - Choosing the protection mode for zones in which gas is present

Explosive Atmosphere	Danger Zone	Protection guaranteed by Equipment	Motor Category	Protection Mode
ALWAYS PRESENT	0	Very High	1G	IEC EN 60079-26
PROBABLE	1	High	2G	Ex d Ex de Ex e
IMPROBABLE	2	Normal	3G	Ex nA

Table 0L - Choice of protection mode for areas where combustible dust is present

Explosive Atmosphere	Danger Zone	Protection guaranteed by Equipment	Motor Category	Protection Mode
ALWAYS PRESENT	20	Very High	1D	Ex ta
PROBABLE	21	High	2D	Ex tb - IP6x
IMPROBABLE	22 Conductive dusts	Normal	2D	Ex tb - IP6x
IMPROBABLE	22 Non-conductive dusts	Normal	3D	Ex tc - IP5x

N. B. Equipment of a higher category can be installed in place of equipment of a lower category.

1. General informations

1.1 Range of motors

The motors presented in this catalogue respect the standards in relation to equipment and protection systems for use on safe areas or potentially explosive atmospheres, in conformity with European directive n. 94/9/CE del 23/3/94, known as the ATEX directive.

Classification of the areas is the responsibility of the user and for the choice of motor the indications are given in Table 1B.

The ATEX directive states that two different certificates of conformity are to be issued. One is the "EC-Type examination certificate" for the homologation of the prototype and the other is for the "Production Quality Assurance Notification".

The certificates are issued by Certification Bodies, defined as Notified Bodies, to which the European Community assigns the task of assessing the conformity of products to community directives.

The list of notified bodies can be found in the site of the European Union on the page <http://ec.europa.eu/enterprise/ach>

The certificates of the motors can be found on Internet at <http://www.cemp.eu>, on the "Product Search" page.

IECEX certificates can also be found at <http://www.iecex.com>

All certificates may be supplied on request.

Table 1A - Temperature Class upon request

Version	T3	T5	T6
63÷160	Same power as T4	Same power as T4	Power lower than T4
180÷315	Same power as T4	Power lower than T4	Power lower than T4

1. General informations

Table 1B - Temp range of motors

Explosion-proof GAS	Type	Version	Frame size [mm]	Output range [kW]	Ventilation	Operation	T4			
							EPL = Gb			
							Ex d	Ex de	Ex d	Ex de
							IIB		IIC	
Explosion-proof GAS	Standard	Single speed, three phase (2, 4, 6, 8 pole)	63 ÷ 315	0.05 ÷ 200.00	IC411	S1	AB 30	AB 35	AC 30	AC 35
		Two speeds, three phase (2/4, 4/8, pole) constant-torque	63 ÷ 315	0.15 ÷ 160.00	IC411	S1	AB 20	AB 25	AC 20	AC 25
		Two speeds, three phase (2/4, 4/8, pole) quadratic-torque	63 ÷ 315	0.18 ÷ 160.00	IC411	S1	AB 40	AB 45	AC 40	AC 45
		Single phase, (2, 4, 6 pole)	63 ÷ 100	0.10 ÷ 3.00	IC411	S1	AB 10	AB 15	AC 10	AC 15
		Single-phase with capacitor in extra-size terminal box (2, 4, 6 pole)	63 ÷ 100	0.10 ÷ 1.10	IC411	S1	AB 12	---	AC 12	---
		Motors energized by inverter (2, 4, 6, 8 pole)	63 ÷ 315	0.09 ÷ 200.00	IC411	S9	AB 70	AB 75	AC 70	AC 75
	With brake	Single speed, three phase (2, 4, 6, 8 pole)	63 ÷ 315	0.05 ÷ 160.00	IC410	S4	DB 30	DB 35	DC 30	DC 35
			71 ÷ 160	0.15 ÷ 18.50	IC411	S4	HB 30	HB 35	HC 30	HC 35
		Single speed, three phase (4, 6, 8 pole)	180 ÷ 315	18.50 ÷ 200.00	IC416	S4	DB 30	DB 35	DC 30	DC 35
			63 ÷ 315	0.05 ÷ 160.00	IC410	S4	DB 20	DB 25	DC 20	DC 25
		Two speeds, three phase (2/4, 4/8, pole) constant-torque	71 ÷ 160	0.15 ÷ 18.50	IC411	S4	HB 20	HB 25	HC 20	HC 25
			180 ÷ 315	18.50 ÷ 160.00	IC416	S4	DB 20	DB 25	DC 20	DC 25
			71 ÷ 315	0.18 ÷ 200.00	IC410	S4	DB 50	DB 55	DC 50	DC 55
		Single speed, three phase (6 pole) for hoist applications	71 ÷ 160	0.18 ÷ 11.00	IC411	S4	HB 50	HB 55	HC 50	HC 55
			180 ÷ 315	15.00 ÷ 160.00	IC416	S4	DB 50	DB 55	DC 50	DC 55
			71 ÷ 315	0.06 ÷ 160.00	IC410	S4	DB 50	DB 55	DC 50	DC 55
		Two speeds, three phase (2/8, 4/12, 4/16 pole) for hoist applications	71 ÷ 160	0.06 ÷ 7.50	IC411	S4	HB 50	HB 55	HC 50	HC 55
			180 ÷ 315	2.00 ÷ 37.00	IC416	S4	DB 50	DB 55	DC 50	DC 55

Explosion-proof GAS + DUST	Type	Version	Frame size [mm]	Output range [kW]	Ventilation	Operation	T4 - T 135°C			
							EPL = Gb - Db			
							Ex d	Ex de	Ex d	Ex de
							IIB		IIC	
Explosion-proof GAS + DUST	Standard	Single speed, three phase (2, 4, 6, 8 pole)	63 ÷ 315	0.05 ÷ 200.00	IC411	S1	AB 30	AB 35	AC 30	AC 35
		Two speeds, three phase (2/4, 4/8, pole) constant-torque	63 ÷ 315	0.15 ÷ 160.00	IC411	S1	AB 20	AB 25	AC 20	AC 25
		Two speeds, three phase (2/4, 4/8, pole) quadratic-torque	63 ÷ 315	0.18 ÷ 160.00	IC411	S1	AB 40	AB 45	AC 40	AC 45
		Single phase, (2, 4, 6 pole)	63 ÷ 100	0.10 ÷ 3.00	IC411	S1	AB 10	AB 15	AC 10	AC 15
		Single-phase with capacitor in extra-size terminal box (2, 4, 6 pole)	63 ÷ 100	0.10 ÷ 1.10	IC411	S1	AB 12	---	AC 12	---
		Motors energized by inverter (2, 4, 6, 8 pole)	63 ÷ 315	0.09 ÷ 200.00	IC411	S9	AB 70	AB 75	AC 70	AC 75
	With brake	Single speed, three phase (2, 4, 6, 8 pole)	63 ÷ 315	0.05 ÷ 160.00	IC410	S4	DB 30	DB 35	DC 30	DC 35
			71 ÷ 160	0.15 ÷ 18.50	IC411	S4	HB 30	HB 35	HC 30	HC 35
		Single speed, three phase (4, 6, 8 pole)	180 ÷ 315	18.50 ÷ 200.00	IC416	S4	DB 30	DB 35	DC 30	DC 35
			63 ÷ 315	0.05 ÷ 160.00	IC410	S4	DB 20	DB 25	DC 20	DC 25
		Two speeds, three phase (2/4, 4/8, pole) constant-torque	71 ÷ 160	0.15 ÷ 18.50	IC411	S4	HB 20	HB 25	HC 20	HC 25
			180 ÷ 315	18.50 ÷ 160.00	IC416	S4	DB 20	DB 25	DC 20	DC 25
			71 ÷ 315	0.18 ÷ 200.00	IC410	S4	DB 50	DB 55	DC 50	DC 55
		Single speed, three phase (6 pole) for hoist applications	71 ÷ 160	0.18 ÷ 11.00	IC411	S4	HB 50	HB 55	HC 50	HC 55
			180 ÷ 315	15.00 ÷ 160.00	IC416	S4	DB 50	DB 55	DC 50	DC 55
			71 ÷ 315	0.06 ÷ 160.00	IC410	S4	DB 50	DB 55	DC 50	DC 55
		Two speeds, three phase (2/8, 4/12, 4/16 pole) for hoist applications	71 ÷ 160	0.06 ÷ 7.50	IC411	S4	HB 50	HB 55	HC 50	HC 55
			180 ÷ 315	2.00 ÷ 37.00	IC416	S4	DB 50	DB 55	DC 50	DC 55

Non sparking GAS	Type	Version	Frame size [mm]	Output range [kW]	Ventilation	Operation	T3	
							EPL = Gc	
							Ex nA	
Non sparking GAS	Standard	Single speed, three phase (2, 4, 6, 8 pole)	63 ÷ 315	0.18 ÷ 200.00	IC411	S1	AN 30	
		Two speeds, three phase (2/4, 4/8, pole) constant-torque	63 ÷ 315	0.15 ÷ 160.00	IC411	S1	AN 30	
		Two speeds, three phase (2/4, 4/8, pole) quadratic-torque	63 ÷ 315	0.18 ÷ 160.00	IC411	S1	AN 30	
		Motors energized by inverter (2, 4, 6, 8 pole)	63 ÷ 315	0.09 ÷ 200.00	IC411	S9	AN 30	

DUST	Type	Version	Frame size [mm]	Output range [kW]	Ventilation	Operation	T 135°C	
							EPL = Db	
							Ex tb	Ex tc
							EPL = Dc	
DUST	Standard	Single speed, three phase (2, 4, 6, 8 pole)	63 ÷ 315	0.18 ÷ 200.00	IC411	S1	AD 30	AD 30
		Two speeds, three phase (2/4, 4/8, pole) constant-torque	63 ÷ 315	0.15 ÷ 160.00	IC411	S1	AD 20	AD 20
		Two speeds, three phase (2/4, 4/8, pole) quadratic-torque	63 ÷ 315	0.18 ÷ 160.00	IC411	S1	AD 40	AD 40
		Single phase, (2, 4, 6 pole)	63 ÷ 100	0.10 ÷ 3.00	IC411	S1	AD 10	AD 10
		Single-phase with capacitor in extra-size terminal box (2, 4, 6 pole)	63 ÷ 100	0.10 ÷ 1.10	IC411	S1	AD 12	AD 12
		Motors energized by inverter (2, 4, 6, 8 pole)	63 ÷ 315	0.09 ÷ 200.00	IC411	S9	AD 70	AD 70
	With brake	Single speed, three phase (2, 4, 6, 8 pole)	63 ÷ 315	0.05 ÷ 160.00	IC410	S4	DD 30	DD 30
			71 ÷ 160	0.15 ÷ 18.50	IC411	S4	HD 30	HD 30
		Single speed, three phase (4, 6, 8 pole)	180 ÷ 315	18.50 ÷ 200.00	IC416	S4	DD 30	DD 30
			63 ÷ 315	0.05 ÷ 160.00	IC410	S4	DD 20	DD 20
		Two speeds, three phase (2/4, 4/8, pole) constant-torque	71 ÷ 160	0.15 ÷ 18.50	IC411	S4	HD 20	HD 20
			180 ÷ 315	18.50 ÷ 160.00	IC416	S4	DD 20	DD 20
			71 ÷ 315	0.18 ÷ 200.00	IC410	S4	DD 50	DD 50
		Single speed, three phase (6 pole) for hoist applications	71 ÷ 160	0.18 ÷ 11.00	IC411	S4	HD 50	HD 50
			180 ÷ 315	15.00 ÷ 160.00	IC416	S4	DD 50	DD 50
			71 ÷ 315	0.06 ÷ 160.00	IC410	S4	DD 50	DD 50
		Two speeds, three phase (2/8, 4/12, 4/16 pole) for hoist applications	71 ÷ 160	0.06 ÷ 7.50	IC411	S4	HD 50	HD 50
			180 ÷ 315	2.00 ÷ 37.00	IC416	S4	DD 50	DD 50

Non sparking + DUST	Type	Version	Frame size [mm]	Output range [kW]	Ventilation	Operation	T3 - T 150°C	
							EPL = Gc - Db	
							Ex nA - Ex tb	Ex nA - Ex tc
Non sparking + DUST	Standard	Single speed, three phase (2, 4, 6, 8 pole)	63 ÷ 315	0.18 ÷ 200.00	IC411	S1	AQ 30	AQ 30
		Two speeds, three phase (2/4, 4/8, pole) constant-torque	63 ÷ 315	0.15 ÷ 160.00	IC411	S1	AQ 20	AQ 20
		Two speeds, three phase (2/4, 4/8, pole) quadratic-torque	63 ÷ 315	0.18 ÷ 160.00	IC411	S1	AQ 40	AQ 40
		Motors energized by inverter (2, 4, 6, 8 pole)	63 ÷ 315	0.18 ÷ 200.00	IC411	S9	AQ 70	AQ 70

MINING	Type	Version	Frame size [mm]	Output range [kW]	Ventilation	Operation	T 150°C	
							EPL = Mb	
							Ex d	Ex de
MINING	Standard	Single speed, three phase (2, 4, 6, 8 pole)	71 ÷ 315	0.15 ÷ 200.00	IC411	S1	AM 30	AM 35
		Two speeds, three phase (2/4, 4/8, 4/6, 6/8 pole) constant-torque	71 ÷ 315	0.37 ÷ 160.00	IC411	S1	AM 20	AM 25
		Two speeds, three phase (2/4, 4/8, 4/6, 6/8 pole) quadratic-torque	71 ÷ 315	0.37 ÷ 160.00	IC411	S1	AM 40	AM 45

1. General informations

1.2 Common main characteristics

- Flameproof motors compliant with the Standards IEC EN 60079-0, 60079-1, 60079-7 for atmospheres where gas is present and IEC EN 60079-31 for areas where combustible dust is present.
- Three phase and single phase Squirrel Cage Asynchronous Induction motors.
- Totally enclosed, fan cooled, frame IP55 with Terminal box IP65.
- The motors dimensions comply with IEC 60072 standard.
- Power Supply 400V/50Hz. Three-phase, 1-speed motors, 2-4-6-8 poles, T4 (for sizes between 63 and 250, multi-voltage power supply 380-400-420V/50Hz and 460V/60Hz).
- Class F insulation.
- Noise level within 86 dB (A).
- Terminal Box:
 - available both in a flameproof, or increased safety version
 - large size
 - standard position - top, opposite feet
 - rotate by 90° in 4 positions.
- Motor frame and terminal box enclosure separated to avoid the transmission of explosions.
- Winding cables connected to the terminal board by means of terminal blocks or by a flameproof sealing device.
- Internal and external mechanical components painted with epoxy polyester powders;
 - stainless steel nameplate,
 - anti-corrosion screws.
- Highly resistant to impact:
 - cast iron made frame, terminal box and endshields.
 - fan cover in sheet steel.
- Low friction dust seals.
- The conformity certificates also cover alternatives, such as:
 - altitude over 1000m
 - modification of the rated voltage and rated frequency
 - power supply from an inverter
 - motor protection through temperature detectors
 - duty S1 to S9.

1.2.1 Special characteristics for motors with brakes

- Mounting options B3, B5, B35, B14, B34.
- Brake power supply:
 - 400V/3/50Hz (for motors with axle height of 63÷160)
 - 230V/1/50Hz (for motors with axle height of 180÷250)
- Double terminal board box, one for the motor and the other for the brake, both can be rotated through 90° in 4 positions, for motors with an axle height of 180÷250.

1.2.2 Special characteristics for motors for mining applications

- The motors in the ATEX series for mines come under group I Category M2. They are intended for use below ground and in surface areas of mines where firedamp or combustible powder can be found. This equipment is meant to be de-energised in an explosive atmosphere.
- Mounting options B3, B5, B35, B14, B34.
- High protection against corrosion:
 - inside and outside surfaces poly-ester powder painting (minimum thickness 150 µm)
 - stainless steel nameplate
 - anticorrosion plated fasteners.
- Highly resistant to impact:
 - special fan cover in sheet steel with rear grid protection.
- The conformity certificates also cover alternatives, such as:
 - modification of the rated voltage and rated frequency
 - power supply from an inverter
 - motor protection through temperature detectors
 - duty S1 to S9.

1.3 Main options

Electrical variants

- Non-standard voltages and frequencies (maximum voltage 1000V).
- Motors for tropical climates.
- Motors for low temperatures (-50°C)
- Temperature rise below 80K.
- Motors insulated to class H.
- Motors with bimetallic detector, thermistor PTC or thermistor PT100.
- Motors with anti-condensation heaters.
- Motors with special electrical design.
- Single-phase motors with capacitor fitted in a large-size terminal box (Ex d, max 50 µF).

Mechanical variants

- Special flanges and shafts.
- Double ended shafts.
- Cable gland fitted to terminal box.
- Terminal box with special cable entries.
- Motors without terminal box with sealing joints and conduits.
- Motors protection IP56 - IP65 - IP66.
- Motors with condensation drainage valves.

- Motors with special bearings (uni-directional, with sensors, with rollers, insulated, oversized, thrust bearings).
- Vibration level Grade A or B, according to IEC 60034-14.
- Motors with a rain cap or sun shield, water-shedding disc.
- Side terminal box frame size 160 to 315.
- Separate terminal box for auxiliary terminals.
- Low noise emission version.
- High protection against corrosion for tropical climates or applications in marine environments:
 - external mechanical components finished with epoxy paint;
 - protection of the internal parts (winding and rotor) with protective paint;
 - stainless steel screws.

Accessories

- Motors suitable for frequency inverter drive.
- Motors with encoder.
- Motors with forced ventilation (from frame size 90).

Certificates

- Motors according to American Bureau of Shipping, Bureau Veritas, Det Norske Veritas, Germanischer Lloyd, Korean Register of Shipping, Lloyd Register of Shipping, Nippon Kaiji Kyokai, R.I.Na., IECEx, CUTR, CCOE.

1.3.1 Further options for motors with brakes

Electrical variants

- Special power supply voltages and frequencies; maximum voltage 690 V both for the motors and the three-phase brake. For single-phase brakes, maximum voltage 440 V.
- Motors with anti-condensate heating coils for both the motor and the brake.
- D.C. current brake
- Positive brake (brakes when energized) with uninterrupted current.

Mechanical variants

- Manual release

1. General informations

1.4 Nomenclature

Pos. 1 = Motor series:

A	Atex	H	Motors with self-ventilating brakes
D	Motors with brakes without ventilation or with forced ventilation		

Pos. 2 = Type of application:

B	Enclosure group IIB	Q	Non sparking + Dust
C	Enclosure group IIC	N	Non sparking
D	Dust	M	Group I for mines

Pos. 3 = Type of motor (electric characteristics):

1	Single phase	4	Three-phase 2 speed quadratic torque
2	Three-phase 2 speed, constant torque	5	For lifting
3	Three-phase 1 speed	7	For inverters

Pos. 4 = Terminal box version:

0	Standard version	5	Protection method Ex e
3	Without box, with plate Ex d	2	Ex d capacitor holder in extra-size box

Pos. 5 = Size (centre height):

63	90	132	200	280
71	100	160	225	315
80	112	180	250	

Pos. 6 = Length of stator pack:

	63	71	80	90	100	112	132	160	180	200	225	250	280	315
							*	*						
Extra short							SA							
Short	A	A	A	S	LA		SB	S	MA		LA	S		S
Medium						M	MB	M	MB	M	M		M	
Long	B	B	B	L	LB		ML	L	L	L	L	LB	M	
Extra long			L									ML		L

* Three-phase, 2-speed version

Pos. 7 = Polarity:

2	2 poles	24	Double polarity: 2 / 4 poles	46	Double polarity: 4 / 6 poles
4	4 poles	28	Double polarity: 2 / 8 poles	48	Double polarity: 4 / 8 poles
6	6 poles	21	Double polarity: 2 / 12 poles	41	Double polarity: 4 / 12 poles
8	8 poles			43	Double polarity: 4 / 16 poles
10	10 poles			68	Double polarity: 6 / 8 poles
12	12 poles			61	Double polarity: 6 / 12 poles

Pos. 8 = Mounting (IM Code I):

B3	V5	V6
B5	V1	V3
B14	V18	V19
B35	V15	V36

Pos. 9 = Version with terminal box:

3F xxxD / xxxS / xx	Three-phase 1-speed; voltage for delta connection; voltage for star connection; frequency
3F xxx / xx	Three-phase, 2-speed: voltage; frequency
1F xxx / xx	Single-phase; voltage; frequency

A B 2 5 132 S 46 B5 3F 400/50 = Example of the commercial codes

2. Design features

2.1 Installation and application

Standard installation

The motors can be installed outdoors and in dusty, moist and chemically aggressive environments (industrial climate) at ambient temperatures from -20°C to 40°C.

Mechanical protection (IP); Table 2A

The mechanical protection systems for electric motors are classified with the IP code followed by two numbers and, in some applications, by a letter.

IP (International Protection):

this indicates the level of protection against accidental contacts of foreign bodies and against water.

0 - 6 (1st digit):

this indicates the level of protection against accidental contacts of foreign bodies.

0 - 8 (2nd digit):

this indicates the level of protection against water.

W, S e M (additional letters for special protections):

W; this means that the machine is to be used in specified weather conditions and with special protections.

The W letter has to be added to the IP code (e. g. IPW55).

S and M; these are used for protection against water.

The letter S stands for static protection; protection against water only for a stationary motor. Letter M stands for protection against water when the motor is running (e. g. IP56S).

Without the additional letters the protection applies in both cases (standing still and running motor).

Our standard motors are IP55 (terminal box IP65).

On request we can supply motors without ventilation with IP56 or IP57, and self ventilated motors with IP56S.

Upper-Deck Installation

Motors meant for installation on board ships and offshore areas are designed to comply with the specifications of the relevant classification authorities (see 1.3 Main options - Certificates).

Gear mounting, Oil-protected Flange

In some applications, it is necessary that the flange and the drive shaft are completely sealed against oil. This need must be specified during the order phase.

Fixed bearings

Some applications need to have a “zero axial play”. This need must be specified during the order phase.

Cooling

Motors are air-cooled by means of external surface ventilation (IC 411).

Standard motors have radial flow fan allowing fully reversible rotation. Reference standards are: IEC 60034-6. From frame size 100 to 315 motors may be supplied with forced ventilation.

Table 2A - Mechanical protection to IEC 60034-5

Protection against accidental contact and the penetration of foreign bodies	International protection	Protection against water
Complete protection against contact and approaching of voltage-carrying parts as well as against contact with rotating parts inside the housing. Protection against harmful dust deposits. The penetration of dust is not completely prevented but the dust cannot enter in such quantities as to affect operation.	IP55 standard design	A jet of water squirting out of a nozzle towards the motor from all directions has no harmful effect.
	IP56 special design	In case of temporary flood, e. g. heavy seas, water cannot enter into the motor in harmful quantities.
	IP57 special design	Motor can operate under water at given pressure.
Complete protection against contact of voltage-carrying parts as well as against contact with rotating parts inside the housing. Protection against the penetration of dust (dust-proof).	IP65 special design	A jet of water squirting out of a nozzle towards the motor from all directions has no harmful effect.
Complete protection against contact of voltage-carrying parts as well as against contact with rotating parts inside the housing. Protection against the penetration of dust (dust-proof).	IP66 special design	In case of temporary flood, e. g. heavy seas, water cannot enter into the motor in harmful quantities.

2.2 Low temperature version and anti-condensation heating

Low Temperature Version

Motors intended for use at extremely low temperatures are specially designed.

Flameproof certificates are valid for temperatures as low as -50°C.

Motors equipped with heating coils keep the minimum temperature of a stopped motor at -20°C (see table 2B).

As an alternative to heaters, the motors can be powered with low voltage via terminals U1 and V1 (see table 2B).

Also, it is possible to use a special construction with suitable materials in low temperature areas (-50°C) as an alternative to heating the motor.

A version is also available for temperature -60°C with other certifications.

Anti-condensation heating

Condensate may form inside the motor due to temperature fluctuations.

To prevent this from happening, motors

must be heated using strip type heaters on the end windings or low voltage power can be supplied to the winding via terminals U1 and V1.

The heat output is given in table 2B.

It is vital that during the motor operation the heaters are turned off.

The supply voltage for the heaters is 230V ± 10% (115V ± 10% on request)

2. Design features

Table 2B - Data of the anti-condensation heater

Frame size	For preventing condensation							For protection at temperatures below -20 °C (down to -50 °C)						
	With heater	Via Motor winding						With heater	Via Motor winding					
		Output [W]	Output [VA]	Heating voltage with a rated motor voltage of					Output [W]	Output [W]	Heating voltage with a rated motor voltage of			
			230V [V]	400V [V]	440V [V]	500V [V]	690V [V]			230V [V]	400V [V]	440V [V]	500V [V]	690V [V]
63	25	35	45	75	90	100	130	50	90	70	120	140	160	210
71	25	55	35	65	75	85	110	50	130	60	100	120	135	175
80	25	70	30	55	65	75	100	50	180	50	90	100	115	155
90	25	100	25	45	50	60	80	50	250	40	70	80	95	125
100	25	140	20	35	40	50	65	50	440	40	65	75	85	115
112	50	190	20	38	45	50	65	100	490	35	60	70	80	105
132	50	300	20	35	40	45	60	100	700	30	55	65	70	90
160	50	420	17	30	35	40	50	100	950	25	45	55	60	80
180	100	500	15	25	30	35	45	200	1200	25	40	50	55	70
200	100	720	13	20	25	30	40	200	1500	20	35	40	45	60
225	100	800	13	20	25	30	40	200	2200	20	35	40	45	60
250	100	950	10	20	25	30	40	200	2700	20	35	40	45	60
280	200	1700	---	20	22	25	30	200	3000	---	28	35	40	50
315	200	1900	---	16	20	25	30	200	3600	---	25	32	38	48
315 L	200	2100	---	14	18	24	30	200	4800	---	22	30	35	45

2.3 Materials, painting and nameplate

2.3.1 Materials

Table 2C - Materials of the main components:

Frame size	63÷250	280÷315
Frame Endshields Terminal box	Cast iron G200 (ISO 185)	Cast iron
Fan cover Rain cap	Steel	Steel
Fan	Non sparking thermoplastic material or aluminium Brass for motors for mining applications	Aluminium Brass for motors for mining applications
Shaft	Steel C45	Steel C45
Rotor	Squirrel cage in pressure cast aluminium	Squirrel cage in pressure cast aluminium
Winding	Insulation class F or H	Insulation class F or H
Bolts and screws	Galvanised steel 8.8 or A4-80 UNI EN ISO 3506-1	Steel 8.8 zinc plated
Cable gland (on request)	Brass or stainless steel	Steel 8.8 zinc plated
Brake enclosure	Cast iron	Cast iron
Brake terminal box	Cast iron	Cast iron

2. Design features

2.3.2 Painting

Table 2D - Materials of the main components:

Frame size	63÷250	280÷315
Pretreatment	All components are sandblasted, cleaned and degreased	All components are sandblasted, cleaned and degreased
Painting	Polymerised epoxy polyester powder, oven-baked at 200°C	Treatment with anti-corrosion primer Final coat of enamel paint
Thickness	Total 120 µm (different thicknesses available upon request)	Total 120 µm (different thicknesses available upon request)
Colour	RAL 5010 (special colours available upon request)	RAL 5010 (special colours available upon request)
Mechanical strength	Non-abrasive, elastic, insensitive to scratches, resistant to impact	Non-abrasive, elastic, insensitive to scratches, resistant to impact
Corrosion resistance	Highly resistant to water, water vapour, salt water	Highly resistant to water, water vapour, salt water
Chemical resistance	Good resistance in chemically aggressive environments	Good resistance in chemically aggressive environments
Temperature range	-40°C +130°C	-40°C +130°C

2.3.3 Nameplate

The stainless steel nameplate is fitted on the motor frame.













<p>   II2G  </p> <p> 0722 CESI 02 ATEX 123 X N m Y14 Electric Motor AC 132SB 2 3~ Exd IIC T4Gb - IP55 </p> <table border="1"> <thead> <tr> <th>V</th> <th>A</th> <th>Hz</th> <th>1/min</th> <th>cosφ</th> <th>kW</th> </tr> </thead> <tbody> <tr> <td>400Δ</td> <td>14,8</td> <td>50</td> <td>2925</td> <td>0,85</td> <td>7,5</td> </tr> <tr> <td>690Y</td> <td>8,55</td> <td></td> <td></td> <td></td> <td></td> </tr> </tbody> </table> <p> IC411 CIF Ta40°C S1 kg 95 </p> <p> <small> Manufacturer Cemp srl - I 20030 SENAGO (Milan) - ITALY Restore the greasing at every opening - fasteners 8.8 ISO 898-1 To be energized with cable suitable for temperature 90°C Warning - Potential danger of electrostatic charge - Read safety instruction </small> </p>	V	A	Hz	1/min	cosφ	kW	400Δ	14,8	50	2925	0,85	7,5	690Y	8,55					<p>   IM2  </p> <p> 0722 CESI 09 ATEX 046 X n Y14 Electric Motor AM30 225S 4 3~ Ex de IMb - IP55 </p> <table border="1"> <thead> <tr> <th>V</th> <th>A</th> <th>Hz</th> <th>1/min</th> <th>cosφ</th> <th>kW</th> </tr> </thead> <tbody> <tr> <td>400Δ</td> <td>69,0</td> <td>50</td> <td>1480</td> <td>0,84</td> <td>37</td> </tr> <tr> <td>690Y</td> <td>39,9</td> <td></td> <td></td> <td></td> <td></td> </tr> </tbody> </table> <p> IC411 CIF Ta40°C S1 kg 360 </p> <p> <small> Manufacturer Cemp srl - I 20030 SENAGO (Milan) - ITALY Restore the greasing at every opening - fasteners 8.8 ISO 898-1 To be energized with cable suitable for temperature 90°C Warning - Potential danger of electrostatic charge - Read safety instruction </small> </p>	V	A	Hz	1/min	cosφ	kW	400Δ	69,0	50	1480	0,84	37	690Y	39,9				
V	A	Hz	1/min	cosφ	kW																																
400Δ	14,8	50	2925	0,85	7,5																																
690Y	8,55																																				
V	A	Hz	1/min	cosφ	kW																																
400Δ	69,0	50	1480	0,84	37																																
690Y	39,9																																				
<p>   II3GD  </p> <p> TUV IT 13ATEX 006 X n Y14 Electric Motor AQ30 90L 4 3~ ExnA IIC T3 Gc Extc IIIC T150°C IP55 </p> <table border="1"> <thead> <tr> <th>V</th> <th>A</th> <th>Hz</th> <th>1/min</th> <th>cosφ</th> <th>kW</th> </tr> </thead> <tbody> <tr> <td>230Δ</td> <td>6,12</td> <td>50</td> <td>1400</td> <td>0,79</td> <td>1,50</td> </tr> <tr> <td>400Y</td> <td>3,54</td> <td></td> <td></td> <td></td> <td></td> </tr> </tbody> </table> <p> IC411 CIF Ta40°C S1 kg 33 </p> <p> <small> Manufacturer Cemp srl - I 20030 SENAGO (Milan) - ITALY fasteners 8.8 ISO 898-1 </small> </p>	V	A	Hz	1/min	cosφ	kW	230Δ	6,12	50	1400	0,79	1,50	400Y	3,54					<p>   II2G  </p> <p> 0722 CESI 12 ATEX 041 X n Y14 Electric Motor DB35 315M 4 3~ Ex de IIC T4Gb - IP55 </p> <table border="1"> <thead> <tr> <th>V</th> <th>A</th> <th>Hz</th> <th>1/min</th> <th>cosφ</th> <th>kW</th> </tr> </thead> <tbody> <tr> <td>400Δ</td> <td>198,5</td> <td>50</td> <td>1488</td> <td>0,85</td> <td>110</td> </tr> <tr> <td>690Y</td> <td>114,7</td> <td></td> <td></td> <td></td> <td></td> </tr> </tbody> </table> <p> Brake K10 140W AC230V/1 1500Nm IC410 CIF Ta40°C S4 40% 50 s/h Jext=0.446 kgm² kg1280 </p> <p> <small> Manufacturer Cemp srl - I 20030 SENAGO (Milan) - ITALY Restore the greasing at every opening - fasteners 8.8 ISO 898-1 To be energized with cable suitable for temperature 90°C Warning - Potential danger of electrostatic charge - Read safety instruction </small> </p>	V	A	Hz	1/min	cosφ	kW	400Δ	198,5	50	1488	0,85	110	690Y	114,7				
V	A	Hz	1/min	cosφ	kW																																
230Δ	6,12	50	1400	0,79	1,50																																
400Y	3,54																																				
V	A	Hz	1/min	cosφ	kW																																
400Δ	198,5	50	1488	0,85	110																																
690Y	114,7																																				

Fig. 2A - Example of plate

2. Design features

2.4 Shaft ends, balancing, vibrations, noise levels, coupling and belt drives

Shaft ends

The shaft ends are cylindrical and comply with IEC 60072 in their design and in their correspondence to frame sizes and outputs. The shaft ends of all motors are equipped with a tapped hole to assist in the fitting of pulleys and couplings. The keys are always supplied along with the motors. On request, special shaft ends or a second free shaft end can be provided. Pole-changing motors with a 2-pole speed have the same shaft ends as single-speed 2-pole motors.

Balancing, and vibration

The motors are dynamically balanced with half keys in accordance with vibration grade "A" (N) normal balance IEC 60034-14 (and ISO 8821). The low-vibration version "B" (R) (reduced) can be supplied where high demands are made on quiet running. Care must be taken to ensure that transmission parts (pulleys, couplings) supplied by others are dynamically balanced with half key.

Noise level

Noise measurements are performed to IEC 60034-9. In the performance data, the sound pressure levels "Lp" are given in dB (A) for the individual frame sizes. They apply for no load at 50 Hz. The tolerance is + 3 dB (A). At 60 Hz the values of sound pressure increase approximately by 4 dB (A).

Coupling drive

When aligning a motor to be coupled directly to the machine, care must be taken that the rollers and balls of the bearings do not jam. Elastic couplings are permissible with all motors. To ensure vibration-free running and to avoid any inadmissible stress on the bearings, the machine to be coupled must still be exactly aligned in the case of elastic coupling. Maximum accuracy must be applied to the coupling of 2-pole motors.

Belt drive

Slide rails are used for motors for easy tensioning and readjustment at the belts. Permissible forces have to be taken into consideration (See Table 2). Pulleys and couplings must only be fitted and removed by means of specific tools.

Table 2E - Vibration limits according to IEC 60034-14

Balancing rate	Limit values of the speed of vibration/oscillation for frame sizes:		
	63÷132 [mm/s]	160÷280 [mm/s]	315 [mm/s]
A	1.6	2.2	2.8
B	0.7	1.1	1.8

Terms of measure: Free standing

2.5 Brake motors

Construction method

Motors in these two series are built with an integrated brake and are considered as an integral unit, consequently, a single ATEX certificate is provided for both motor and brake.

The brake is enclosed in a special enclosure built with a Ex d IIB or IIC protection type and IP65 mechanical protection.

The temperature class and maximum surface temperature are those of the motor. The electro-magnet winding is encapsulated in resin which isolates it and provides mechanical protection.

Motors with an axle height of 63 to 160 are normally fitted with a three-phase magneto with a power supply of 110V to 690V.

Alternatively, upon request, a magneto can be supplied with a direct current power supply using a rectifier, with a single-phase power supply of 48V to 440V.

If you have a direct current power supply line, the magneto can be powered directly using that line (from 24V to 230V).

Motors with an axle height of 180 to 250 use a "K10" type brake, which is only available with the magneto powered using direct current. This type of brake is always supplied with a direct current power supply using a rectifier, with a single-phase power supply of 48V to 440V.

Operation

The brake is made up of:

- the magnet;
- the counter-magnet (or mobil armature) supported by three small columns where it can slide;
- braking disk
- toothed hub secured to the motor shaft.

When the coil is powered, the magnet attracts the mobil armature which thus releases the braking disk so the motor can rotate freely.

By removing voltage to the magnet, the springs push the mobil armature against the braking disk, which, by creating friction against the motor shield, locks the shaft rotation.

In rest conditions, when the brake is not powered, the motor remains locked.

2. Design features

Braking torque calibration

The motor is supplied with a ready-to-use calibrated brake.

Special calibration available on request.

This is carried out during assembly before final testing.

Table 2F shows the standard braking torques.

Manual release

DB - DC and HB - HC series flameproof motors with brake can be supplied on request with hand release lever for the brake.

Pressure is applied on the release mechanism which moves the mobile armature, freeing the motor's shaft.

When releasing pressure on the mechanism the brake automatically returns to the fail safe position.

Variants (63÷160)

On request: brake motors can be supplied with single-phase power supply brakes between 110V and 400V. This version is only available in the Ex d version, the terminal box contains a rectifier.

- supplied with D.C. current between 24V and 260V

- positive braking-when power is applied, the brake activates and locks on. With the power supply off, the brake is not energized and the motor shaft rotates freely. The positive brake is available only with D.C. current for motors with 90÷100 axis height.

Table 2F - Standard technical data of the integrated brake

Frame size	Brake model	Static braking torque [Nm]	Air gap (+0.1 / 0) [mm]	On-off braking time requested [ms]	Number of disks [n°]	Maximum speed [1/min]	Power [VA]	Current max. [A]
63	AC1	4	0.2	20	1	3600	40	---
71	MEC 63	9	0.3	25	1	3600	50	---
80	T80	17	0.3	30	1	3600	60	---
90	MEC 80	35	0.3	40	1	3600	14	---
100	MEC 90 (♦)	48	0.3	40	1	3600	180	---
112	MEC 100 (♦)	70	0.3	45	1	3600	250	---
132	MEC 110 (♦)	90	0.3	90	1	3600	400	---
160	T140 (♦)	130	0.3	100	1	3600	480	---
180÷200	K10	400	0,3	220	1	1800	140	1,5
225÷250	K10	800	0,3	220	1	1800	140	1,5
280÷315 S-M	K10	240 - 400 - 800	0,3	220	1	1800	140	1,5
		1500		220				

(♦) 2 brake discs available by request (braking torque about + 50%).

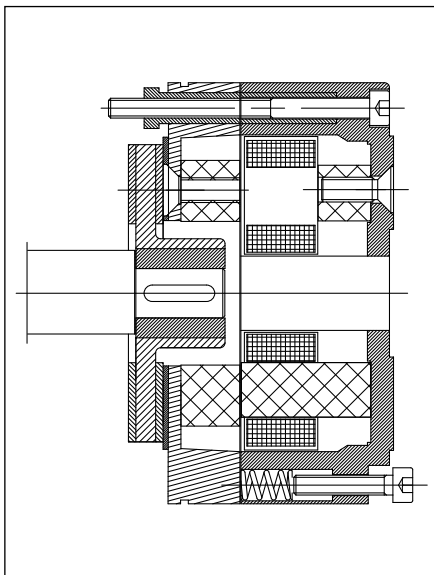

Fig. 2B - Construction diagram for a 63÷160 brake

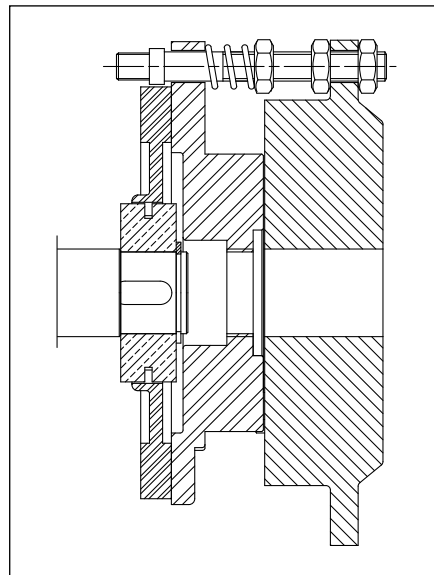

Fig. 2C - Construction diagram for a 71÷160 brake

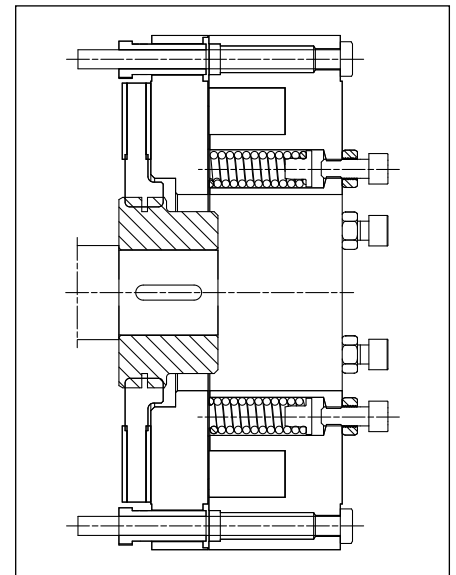

Fig. 2D - Construction diagram for a 180÷315 brake

2. Design features

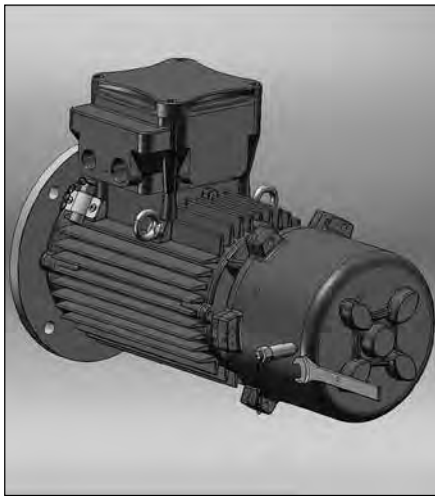

Fig. 2E -
Manual release (optional on request)
for motors 71÷160 not ventilated

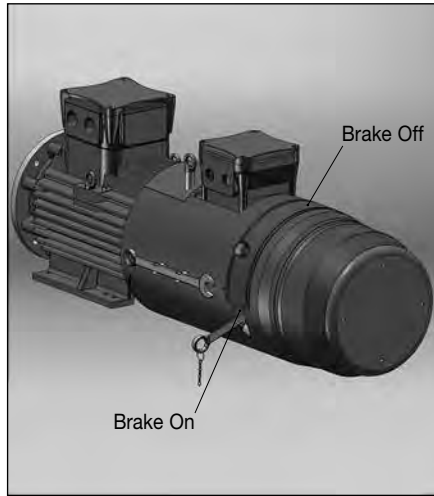

Fig. 2F -
Manual release (optional on request)
for motors 180÷315 with forced ventilation

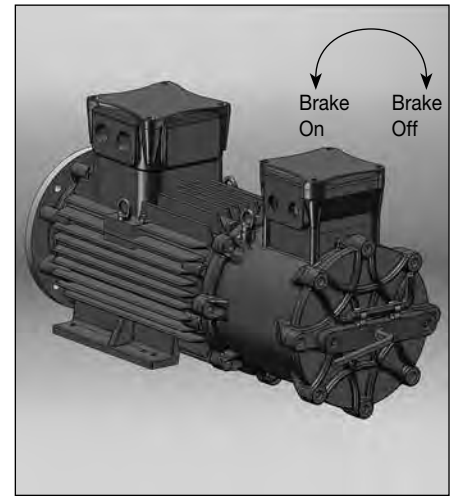

Fig. 2G -
Manual release (optional on request)
for motors 180÷315 not ventilated

2.6 Bearing system

Standard motors are equipped with radial deep groove ball bearings (ZZ pre-greased series) or open bearings complete with grease nipples.

Where requested roller, or other special bearings can be fitted.

Lubrication

The ZZ series bearings are lubricated for life and require no further lubrication.

Open bearings are supplied with grease nipples and are to be lubricated according to the indications given in the table 2G - 2H.

Bearing Seal

In order to prevent dust and water penetration, a seal ring is fitted to the endshield on the driving and non-driving ends.

These seal rings are highly resistant to vibrations, thermally stable, and resistant to mineral oils and diluted acids.

Seals for media not listed above are available on request.

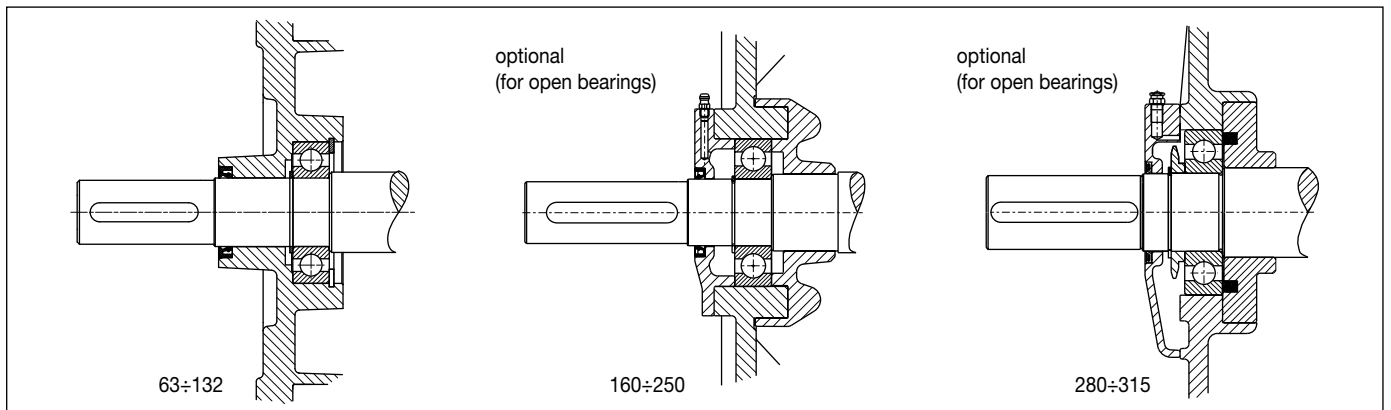

Fig. 2H - Ball bearings - DE (front)

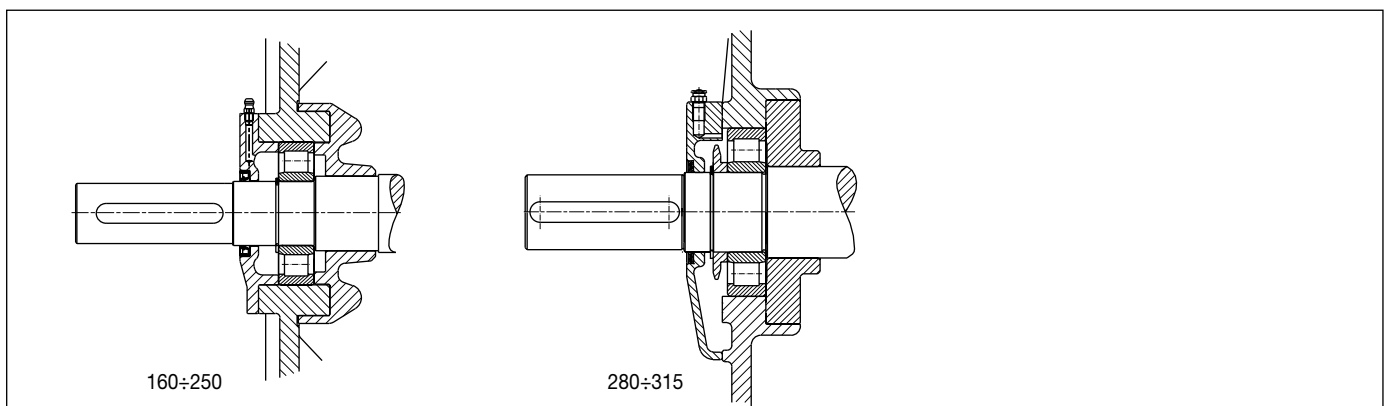

Fig. 2I - Roller bearings - On request execution DE (front)

2. Design features

Table 2G - Standard model -
Closed non-lubricated bearings

Frame size	Poles	Bearing	
		Drive end	Non-Drive end
63	2 - 4 - 6 - 8	6202 ZZ	
71	2 - 4 - 6 - 8	6203 ZZ	
80	2 - 4 - 6 - 8	6204 ZZ	
90	2 - 4 - 6 - 8	6205 ZZ	
100	2 - 4 - 6 - 8	6206 ZZ	
112	2 - 4 - 6 - 8	6306 ZZ	
132	2 - 4 - 6 - 8	6308 ZZ C3	
160	2 - 4 - 6 - 8	6309 ZZ C3	
180	2 - 4 - 6 - 8	6310 ZZ C3	
200	2 - 4 - 6 - 8	6312 ZZ C3	
225	2 - 4 - 6 - 8	6313 ZZ C3	
250	2	6313 ZZ C3	
	4 - 6 - 8	6314 ZZ C3	6313 ZZ C3
280 horizontal	2 - 4 - 6 - 8	6316 ZZ C3	
280 vertical	2 - 4 - 6 - 8	6316 C3	
315 horizontal	2	6316 ZZ C3	
	4 - 6 - 8	6317 ZZ C3	6316 ZZ C3
315 vertical	2	6316 C3	
	4 - 6 - 8	6317 C3	6316 C3

Table 2H - Upon request -
Open bearings with lubricators

Frame size	Poles	Bearing			Time interval for lubrication (hours)	Amount of grease*
		Front ball bearings	Front rollers	Rear ball bearings		
160	2	6309 C3	NU 309	6309 C3	5500	12 g
	4				8250	
	6 - 8				11000	
180	2	6310 C3	NU 310	6310 C3	2000	12 g
	4				6000	15 g
	6 - 8				7000	
200	2	6312 C3	NU 312	6312 C3	2100	12 g
	4				5000	15 g
	6 - 8				7000	
225	2	6313 C3	NU 313	6313 C3	2000	15 g
	4				4500	
	6				5600	
	8				6400	
250	2	6313 C3	NU 313	6313 C3	2000	20 g
	4	6314 C3	NU 314		4100	
	6				5300	
	8				6200	
280 S	2	6316 C3	NU 316	6316 C3	3700	33 g
	4				4300	
	6				4600	
	8				4800	
280 M	2	6316 C3	NU 316	6316 C3	3700	33 g
	4				4300	
	6				4600	
	8				4800	
315 S	2	6316 C3	NU 316	6316 C3	3300	37 g
	4	6317 C3	NU 317		9500	
	6				13700	
	8				15300	
315 M	2	6316 C3	NU 316	6316 C3	2900	37 g
	4	6317 C3	NU 317		7800	
	6				11300	
	8				13600	
315 LA	2	6316 C3	NU 316	6316 C3	4100	33 g
	4 - 6	6317 C3	NU 317		11100	
	8				19500	
315 LB	2	6316 C3	NU 316	6316 C3	3500	37 g
	4 - 6	6317 C3	NU 317		9500	
	8				16550	
315 LC	2	6316 C3	NU 316	6316 C3	2900	33 g
	4 - 6	6317 C3	NU 317		7800	
	8				13600	

* Grease type LGHP2 SKF or equivalent.

2. Design features

2.7 Permissible radial loads on the shaft with standard bearings

Table 21 shows the values of radial load calculated considering:

- frequency 50Hz;
- temperature not exceeding 90°C;
- 20,000 hours of life for 2-pole motors;
- 40,000 hours of life for 4, 6, 8-pole motors.

For operation at 60Hz the values have to be reduced by 6% in order to achieve the same useful life. For double speed motors, consider always the higher speed.

The distance of the point of action of force F_R from the shoulder of the shaft must not exceed the length of the shaft end.

F_R = maximum radial load (e. g. belt load + weight of belt pulley)

$$F = \text{belt load [N]} = \frac{2 \cdot K \cdot M}{D}$$

$$M = \text{torque [Nm]} = \frac{9550 \cdot P}{n}$$

P = rated motor output [kW]

n = rated motor speed [1/min]

D = belt pulley diameter [m]

K = prestress factor governed by belt type: it is assumed approximately as follows

$K = 3$ for normal flat belts without tensioning pulley

$K = 2$ for normal flat belts with tensioning pulley

$K = 2.2$ for V-belts or special flat belts

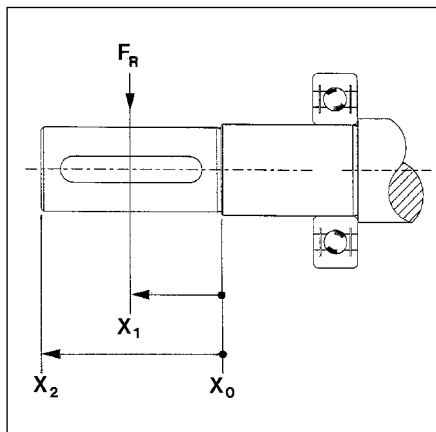

Fig. 2L

Table 21

Frame size	Pole number	Permissible radial load F_R [N]					
		Ball bearings			Roller bearings		
		X_0	X_1	X_2	X_0	X_1	X_2
63	2	390	360	340	---	---	---
	4	390	360	340	---	---	---
	6	440	410	380	---	---	---
	8	490	450	420	---	---	---
71	2	490	450	420	---	---	---
	4	480	450	420	---	---	---
	6	550	510	480	---	---	---
	8	610	560	520	---	---	---
80	2	640	590	540	---	---	---
	4	640	580	540	---	---	---
	6	730	660	610	---	---	---
	8	800	730	670	---	---	---
90	2	730	660	610	---	---	---
	4	720	660	600	---	---	---
	6	820	750	680	---	---	---
	8	910	820	750	---	---	---
100	2	1020	910	830	---	---	---
	4	1010	910	820	---	---	---
	6	1150	1030	940	---	---	---
	8	1270	1140	1030	---	---	---
112	2	1480	1350	1240	---	---	---
	4	1470	1340	1230	---	---	---
	6	1680	1530	1410	---	---	---
	8	1850	1680	1550	---	---	---
132	2	2160	1930	1750	---	---	---
	4	2140	1910	1720	---	---	---
	6	2450	2190	1970	---	---	---
	8	2700	2410	2180	---	---	---
160	2	2790	2470	2210	5720	5200	4680
	4	2770	2450	2190	5885	5350	4815
	6	3150	2790	2490	5995	5450	4905
	8	3480	3080	2750	6050	5500	4950
180	2	3600	3200	2950	6490	5900	5310
	4	3500	3350	2850	7040	6400	5760
	6	3900	3600	3300	7370	6700	6030
	8	4300	3950	3700	7480	6800	6120
200	2	4500	4300	4000	9680	8800	7920
	4	4550	4350	4100	10450	9500	8550
	6	5300	5500	5000	10780	9800	8820
	8	5500	5350	5050	10945	9950	8955
225	2	5500	5000	4650	11880	10800	9720
	4	5350	4900	4500	12760	11600	10440
	6	5950	5650	5200	13200	12000	10800
	8	6400	6100	5700	13420	12200	10980
250	2	5300	5100	4750	13860	12600	11340
	4	5650	5400	5300	15950	14500	13050
	6	5820	5600	5370	16500	15000	13500
	8	6420	5980	5520	16665	15150	13635
280	2	5500	5000	4500	15400	14000	12600
	4	5665	5150	4635	15950	14500	13050
	6	6930	6300	5670	16500	15000	13500
	8	7920	7200	6480	18150	16500	14850
315 S-M	2	5500	5000	4500	14300	13000	11700
	4	6270	5700	5130	28050	25500	22950
	6	7370	6700	6030	29150	26500	23850
	8	8360	7600	6840	29700	27000	24300
315 L	2	6820	6200	5580	13640	12400	11160
	4	7095	6450	5805	24750	22500	20250
	6	8030	7300	6570	27500	25000	22500
	8	9020	8200	7380	30800	28000	25200

2. Design features

2.8 Permissible axial load on the shaft with standard bearings

If the shaft end is loaded at X^2 with the permissible radial load F_A , an additional axial load is allowed (table 2L).

If the permissible radial load is not fully utilized, higher loads are possible in axial direction (Values on request).

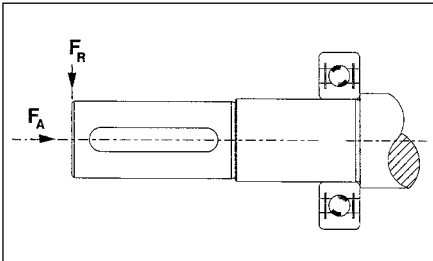

Fig. 2M

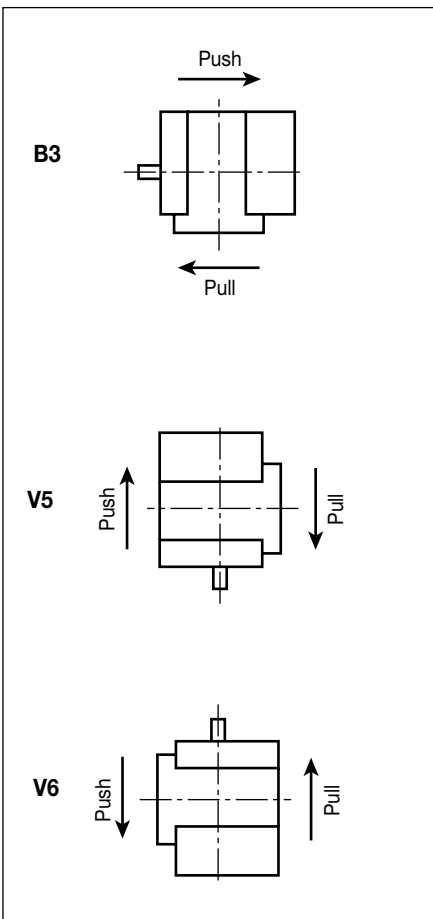

Fig. 2N

Table 2L

Frame size	Pole number	Limit axial load with F_R at X_2 - F_A [N]			
		Ball bearings		Roller bearings	
		B3 push/pull	V5/V6 push/pull	B3 push/pull	V5/V6 push/pull
63	2	120	110	---	---
	4	120	110	---	---
	6	140	130	---	---
	8	160	150	---	---
71	2	140	130	---	---
	4	140	120	---	---
	6	170	150	---	---
80	2	190	170	---	---
	4	190	160	---	---
	6	220	190	---	---
90	2	250	220	---	---
	4	200	170	---	---
	6	200	160	---	---
100	2	240	190	---	---
	4	270	220	---	---
	6	280	230	---	---
112	2	280	220	---	---
	4	330	260	---	---
	6	370	300	---	---
132	2	410	330	---	---
	4	410	320	---	---
	6	480	370	---	---
160	2	540	430	---	---
	4	590	380	---	---
	6	690	470	---	---
180	2	780	560	---	---
	4	750	490	1000	700
	6	750	450	1200	840
200	2	880	520	1300	910
	4	880	480	1400	980
	6	1000	640	1400	980
225	2	880	950	1000	700
	4	880	1150	1250	875
	6	1030	1350	1350	945
250	2	1160	1550	1550	1085
	4	1160	1100	1100	770
	6	1160	1200	1200	840
280	2	1360	1400	1400	980
	4	1520	1600	1600	1120
	6	1300	1250	1250	875
315 S-M	2	1300	1350	1350	945
	4	1520	1600	1600	1120
	6	1710	1850	1850	1295
315 L	2	1460	1300	1300	910
	4	1460	1400	1400	980
	6	1710	1600	1600	1120
315 L	2	1920	1920	1900	1330
	4	5500	3850	3700	2590
	6	5500	3850	3700	2590
315 S-M	2	6500	4550	4000	2800
	4	7400	5180	4500	3150
	6	5500	3850	3700	2590
315 L	2	5800	4060	3500	2450
	4	6800	4760	4000	2800
	6	7650	5355	4500	3150
315 L	2	2200	1540	3850	2695
	4	2200	1540	3800	2660
	6	2500	1750	4600	3220
315 L	2	3000	2100	5500	3850
	4	3000	2100	5500	3850

2. Design features

2.9 Terminal box design

The standard design has four basic versions:

- Ex d IIB
- Ex d IIC
- Ex de IIB
- Ex de IIC

On request we can supply:

- additional terminal box for auxiliary terminals (Fig. 2P)
- motors without terminal box and with leads (Fig. 2Q)
- bigger terminal box with capacitor for single phase motors (Fig. 2R).

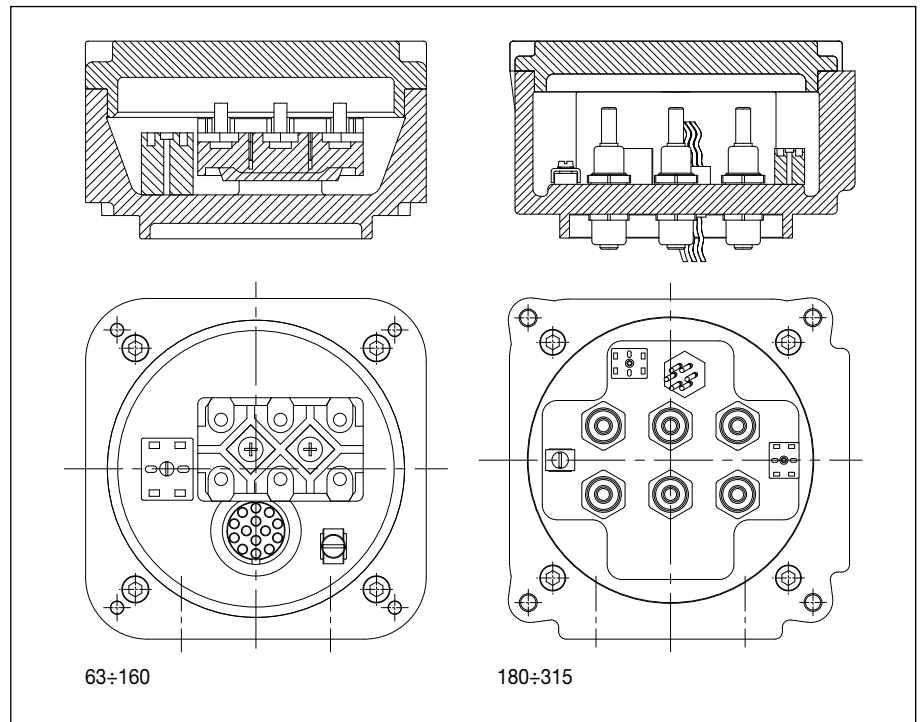

Fig. 20 - Standard motor version terminal box Ex d, group IIB

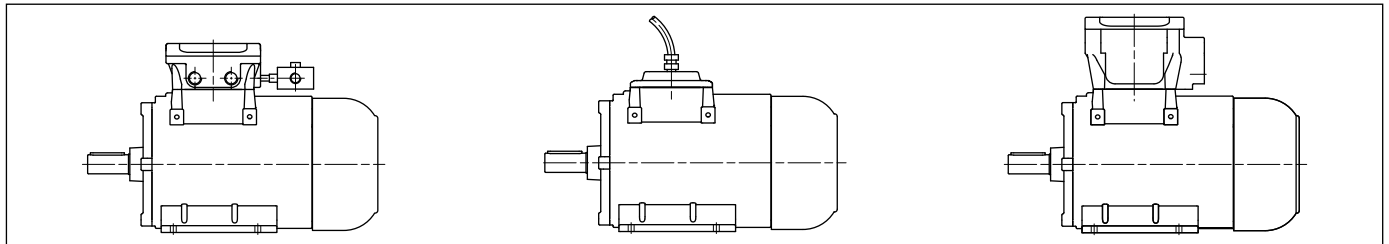

Fig. 2P

Fig. 2Q

Fig. 2R

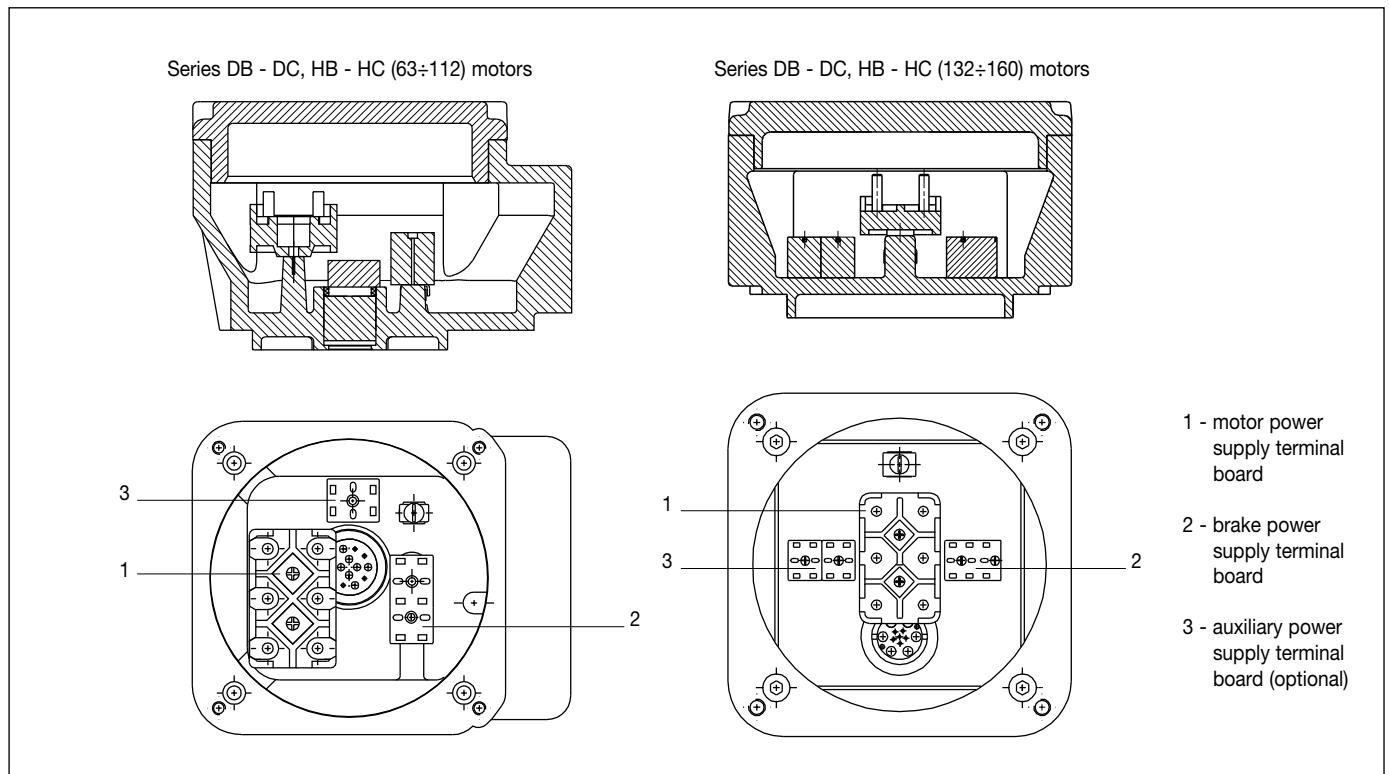

Fig. 2S - Motor with brake terminal box

2. Design features

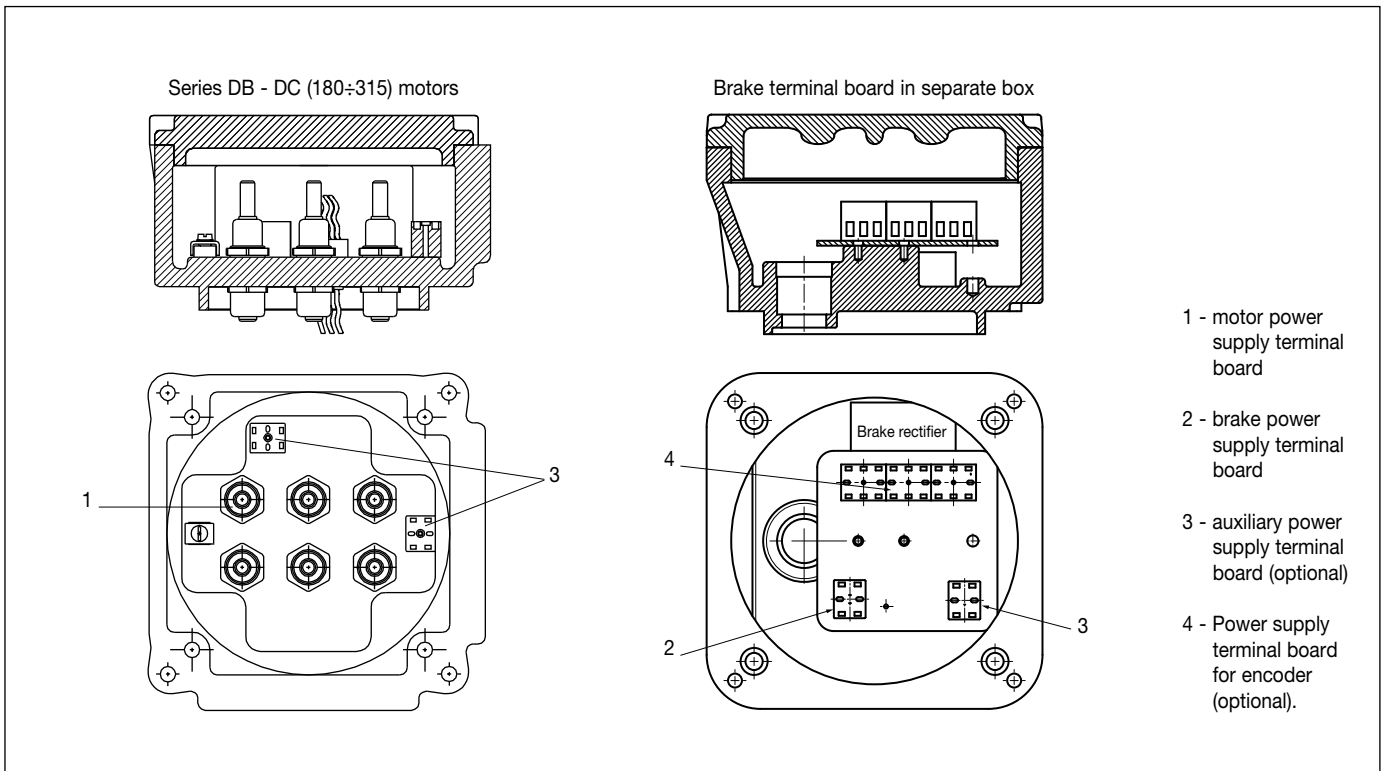

Fig. 2T - Motor with brake terminal box

2.10 Position of terminal box and terminals

The terminal box is usually located on top and can be turned through $4 \times 90^\circ$ (Fig. 2U).

For a horizontal mounted motor, the cable entry is normally located on the right side (looking at the driving-end).

Cable entry:

- standard position: 1
- special positions upon request: 2, 3, 4.

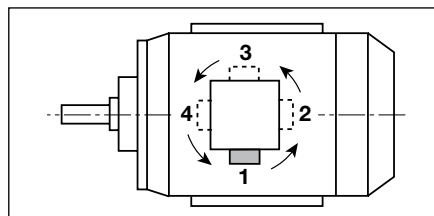

Fig. 2U - Positioning of the cable entry, plan view

Terminals and earthing terminal

There are a maximum number of 6 power terminals in the terminal box.

The type of monitoring device depends on

the number of possible additional terminals in the main terminal box.

PTC thermistors can be connected to two additional terminals.

Two terminals are also necessary for connecting the anticondensation heater.

For PT 100 (RTD) thermistors, 3 or 4 terminals are necessary depending on the type chosen.

An earthing terminal is located in the terminal box and another earthing terminal is located on motor frame.

2.11 Cable-entries

As standard, the motors are delivered with one or two threaded cable entries for flameproof packing glands.

Ex de motors can be also provided with Ex e packing glands.

Motors fitted with thermodetectors or heaters are always provided with additional cable entry.

Table 2M

Mains connection cable entries				
Frame size	Mains power supply	Power supply from an inverter	Conical threading upon request*	
			ANSI B 2.1	UNI 6125
63 ÷ 112	1 x M25	1 x M25 + 1 x M20	NPT 3/4"	Gk 3/4"
132 ÷ 160	2 x M32	1 x M32 + 1 x M20	NPT 1"	Gk 1"
180 ÷ 250	2 x M40	1 x M40 + 1 x M20	NPT 1.1/4"	Gk 1.1/4"
280 ÷ 315	2 x M63	1 x M63 + 1 x M20	NPT 2"	Gk 2"
Auxiliaries cable entries				
63 ÷ 315	----	1 x M20	NPT 1/2"	Gk 1/2"

* Other threads available upon request

3. Electrical design

3.1 Standard operating conditions

Output

The rated outputs and operating characteristics given in the performance data refer according to IEC 60034-1 to:

- continuous duty (S1)
- frequency of 50Hz
- voltage 400V (230V for single phase)
- maximum ambient temperature of 40°C
- maximum height of installation of 1000m above sea level.

Motors (IIB, Ex d or Ex nA or Ex t) can also be operated in ambient temperatures from 40°C to 80°C and at altitudes of more than 1000m to 4000m above sea level.

In these cases, the rated output given in the tables must be reduced in accordance with table 3A or a larger motor has to be chosen.

The rated data does not need to be changed, if at altitudes in excess of 1000 m above sea level, the ambient temperature is reduced according to the following table:

Altitude of installation [m]	Maximum ambient temperature [°C]
0 to 1000	40
1000 to 2000	30
2000 to 3000	19
3000 to 4000	9

Voltage, frequency

The motors as standard are built to run at the voltage and frequency with the tolerances indicated in figure 3A.

The motors can run with the variations envisaged in normal operational areas at a voltage of ± 5% and frequency of ± 2%.

Furthermore, the motors can be used in the operational area with restrictions (variations in voltage of ± 10% and frequency of ± 3%) as long as the indications given by norm 60034-1 are complied with.

Torque

The motors are fitted with squirrel-cage rotors suitable for direct-on-line starting.

The resulting starting and maximum torques, expressed as a multiple of the rated torques are given in the performance data.

A deviation in the voltage from the rated value changes the torques as an approximate function of the square of the voltages.

Normally two-speed motors have a nominal torque that is roughly the same for both speeds.

A version is also available with quadratic torque, for centrifugal machines (fans, pumps). In this case, the torque at the lower speed is roughly half that available at the higher speed.

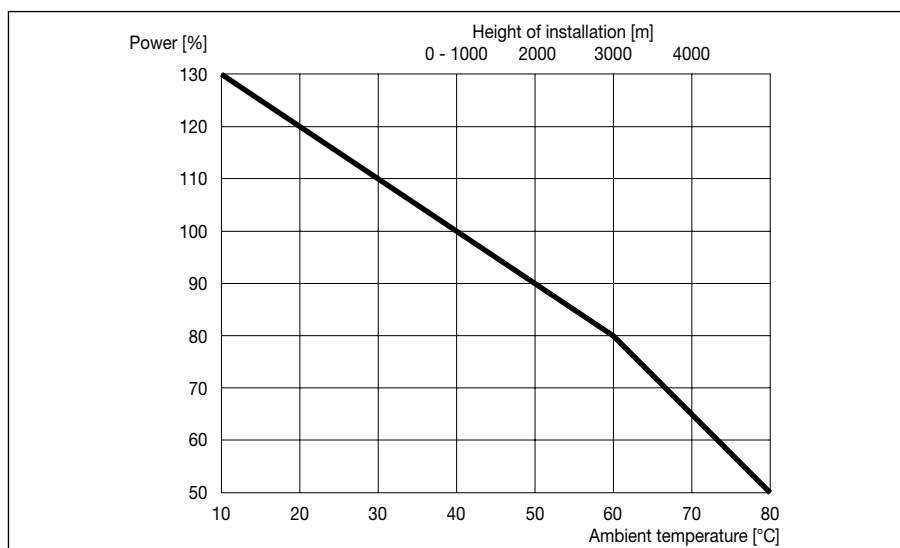

Table 3A - Power variation of standard motors in case of coolant temperature different from 40°C or height of installation over 1000 m above sea-level

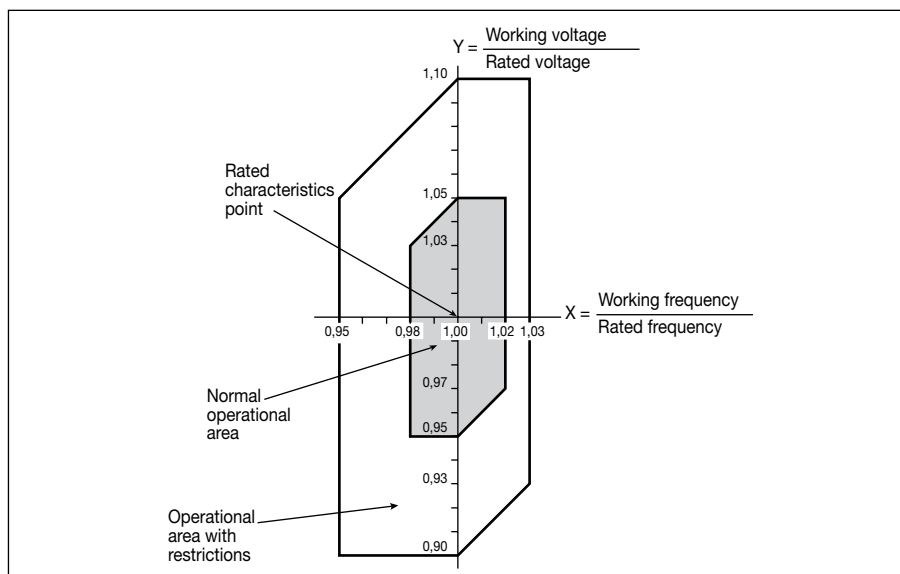

Fig. 3A

Rated current

In the performance data the rated currents are only indicated for a rated voltage of 400V.

For other voltages the rated currents are inversely proportional to the voltages:

$$\frac{U}{U'} = \frac{I'}{I}$$

This results in:

$$I' = \frac{U \cdot I}{U'}$$

Speed

The rated speeds shown in the performance data are valid for 50 Hz and the rated speed equals synchronous speed less slip.

The following speeds result from the number of poles and the mains frequencies of 50 and 60Hz:

Pole number	No-load speed at	
	50Hz [1/min]	60Hz [1/min]
2	3000	3600
4	1500	1800
6	1000	1200
8	750	900
10	600	720
12	500	600
16	375	450

Direction of rotation

The motors can be operated in both directions of rotation. If the phases are connected in the sequence L1, L2, L3 to the terminals U1, V1, W1, the motor turns clockwise.

The direction of rotation can be reversed by interchanging any two phases.

3. Electrical design

Note regarding electro-magnetic compatibility

Low voltage induction motors, if installed correctly and connected to the power supply, respect all immunity and emission limits as set out in the regulations relating to electro-magnetic compatibility (EMC “Generic Standard” for industrial environments).

In the case of supply by means of electronic impulse devices (inverters, soft starters etc.), all verifications and any modifications, necessary to ensure that emission and immunity limits, as stated within the regulations, are respected, are the responsibility of the installer.

Tolerances

According to IEC 60034-1 the electrical data stated in the tables are subject to the following tolerances:

Efficiency:

$P_n \leq 50 \text{ kW}$: - 0.15 (1- η)

$P_n > 50 \text{ kW}$: - 0.10 (1- η)

Power factor: - $\frac{1 - \cos \phi}{6}$

(minimum 0.02 - maximum 0.07)

Slip at rated load operating temperature: $\pm 20\%$ of rated slip.

Locked rotor torque (starting torque): - 15% + 25%

Maximum torque: - 10%.

Current with locked rotor: + 20% (no lower limit).

3.2 Efficiency and power factor at partial load

The efficiency and power factor values shown in the performance data refer to rated output at 50Hz.

3.3 Insulation and temperature rise

Insulation

The components of the insulation system were selected so as to ensure good protection against chemically aggressive gases, vapours, dust, oil and air humidity. All materials used for insulating the winding and winding ends correspond to insulating classes F or H according to IEC 60085:

- Enamel-insulated copper wires with temperature index 200 (class H);
- Insulating sheet on polyester base (class F);
- Impregnation with fenolic resins modified with polyesther resins (class H);

Table 3B - Limit temperature for insulating material according IEC 60085

Insulation class	Limit temperature [°C]
B	130
F	155
H	180

Temperature rise

Standard single-speed motors in continuous service (excluding 315M) have temperature rises that are within the limits for class B.

Motors with higher output and pole-changing motors normally have temperature rise within class F limit.

Table 3C - Temperature rise limit for rotating machines according IEC 60034-1

Insulation class	Max temperature rise [K]
B	80
F	105
H	125

According to Normative IEC 60034-1, the values shown in the table above may be up to 10°C higher, with a feeding current variance of $\pm 5\%$.

3. Electrical design

3.4 Duty types

In compliance with IEC 60034-1 the following duty-types are distinguished:

Duty-type S1 - continuous running duty. Constant load operation.

Duty-type S2 - short-time duty. Operating times of 10, 30, 60, and 90 minutes are recommended. After each operating period the motor remains de-energized until the winding has cooled down to the ambient temperature.

Duty-type where start-ups DO NOT INFLUENCE winding over-heating:

Duty-type S3 - intermittent periodic duty. Where starting does not influence the temperature. Duty cycle 10 minutes unless otherwise agreed upon. For the cyclic duration factor the values 15, 25, 40, and 60% are recommended.

Duty-type S6 - continuous operation periodic duty. Duty cycle 10 minutes unless otherwise

agreed upon. For the cyclic duration factor the value 15, 25, 40, and 60% are recommended.

Duty-types where starting and braking have a corresponding INFLUENCE on the temperature rise of the winding:

Duty-type S4 - intermittent periodic duty with starting. Intermittent periodical operation with identical cycles.

Duty-type S5 - intermittent periodic duty with electric braking. Intermittent periodical operation with identical cycles, which include an electrical braking phase.

For S4 and S5 duty-types the following details must be given after this code:

- Intermittence ratio;
- The number of starts per hour;
- Moment of inertia of the motor;
- Moment of inertia of the load.

Duty-type S7 - continuous operation periodic duty with electric braking.

Duty-type S8 - continuous operation periodic duty with related load/speed changes.

Duty-type S9 - duty with non-periodical load and speed variations. Typical operation for motors powered by frequency converters.

Most of the real duty-type conditions represent a combination of duty-types as mentioned under 1. and 2. In order to exactly determine a suitable motor, details of all the operating conditions are required.

N.B.:

The output ratings stated in the "Performance data" (Chapter 4.) apply to duty-type S1.

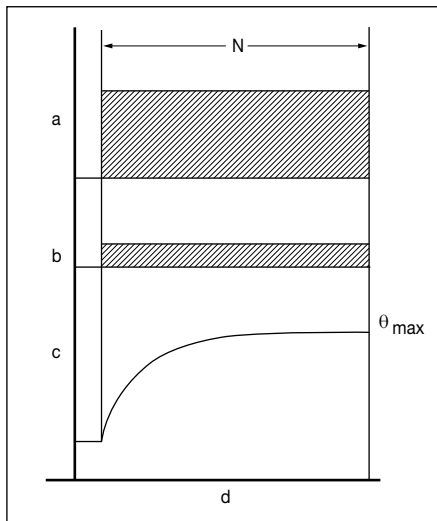

Fig. 3B - Duty type S1

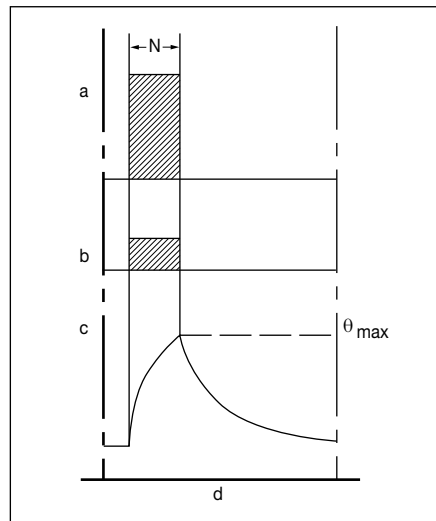

Fig. 3C - Duty type S2

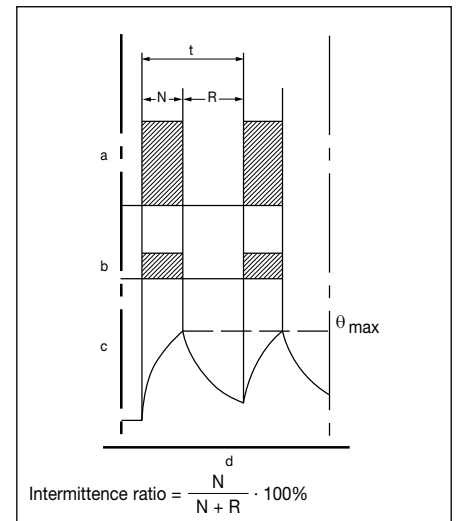

Fig. 3D - Duty type S3

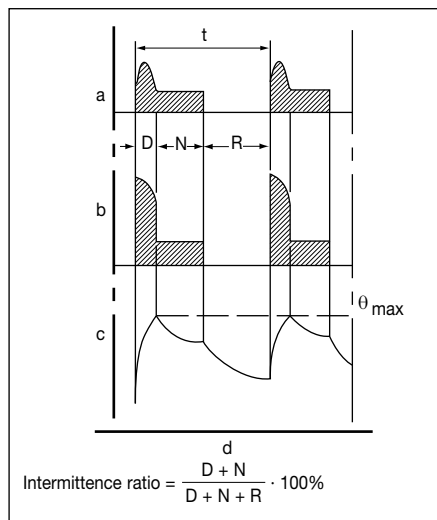

Fig. 3E - Duty type S4

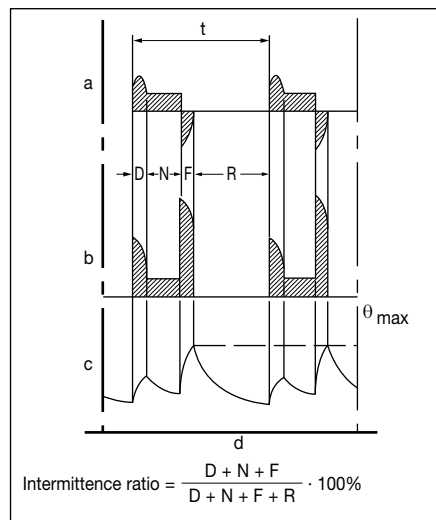

Fig. 3F - Duty type S5

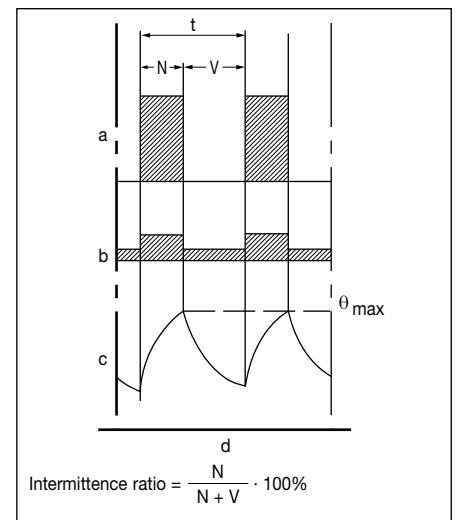

Fig. 3G - Duty type S6

3. Electrical design

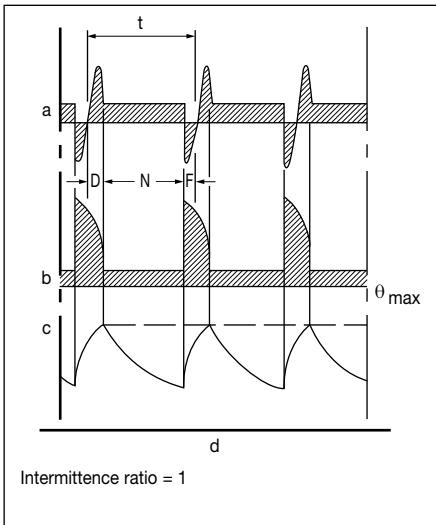

Fig. 3H - Duty type S7

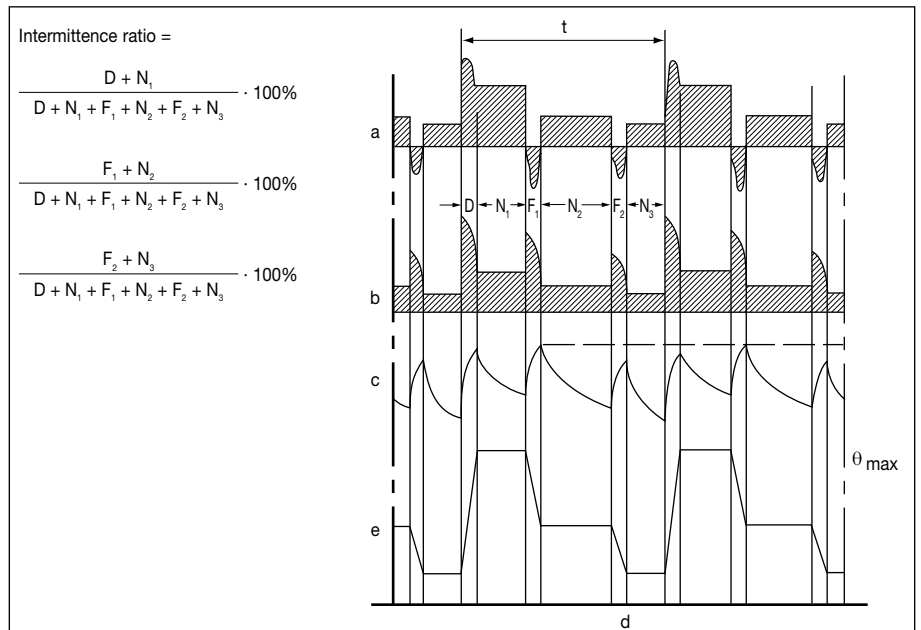

Fig. 3I - Duty type S8

Table 3D - Simbology

a	= Load
b	= Electrical losses
c	= Temperature
d	= Time
e	= Speed
t	= Cycle length
D	= Start-up or acceleration time
F, F ₁ , F ₂	= Electrical braking time
N, N ₁ , N ₂ , N ₃	= Constant load operating time
L	= Variable load operating time
V	= No-load operating time
R	= Rest time
S	= Overload operating time
P	= Full load
θ _{max}	= Maximum temperature reached during cycle

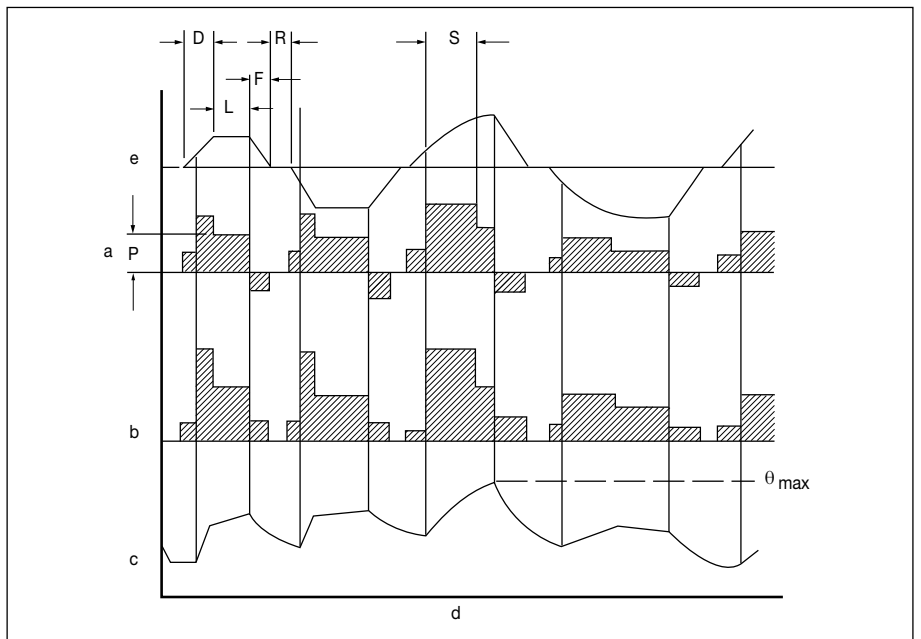

Fig. 3L - Duty type S9

3. Electrical design

3.5 Connecting diagrams

3.5.1 Three-phase motors

Single-speed motors are normally pre-arranged to be connected in star or delta method.

Star connection

Connecting together the W2, U2, V2 terminals (star point) and connecting to the mains the U1, V1, W1 terminals a star connection is obtained.

The phase current I_{ph} and the phase voltage U_{ph} are the following:

$$I_{ph} = I_n$$

$$U_{ph} = U_n / \sqrt{3}$$

where I_n the line current and U_n is the line voltage.

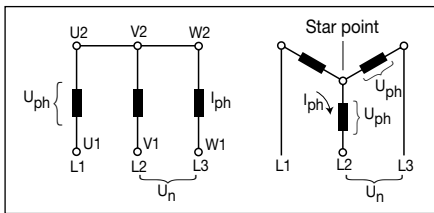

Fig. 3M

Delta connection

Connecting the end of each winding to the beginning of the next winding a delta connection is obtained.

The phase current I_{ph} and the phase voltage U_{ph} are the following:

$$I_{ph} = I_n / \sqrt{3}$$

$$U_{ph} = U_n$$

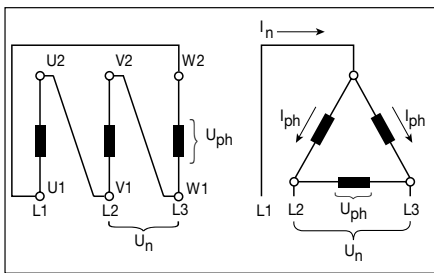

Fig. 3N

Star - Delta starting

The star-delta starting is an easy way to reduce the starting current and starting torque.

Motors can be started with the star-delta starting method whenever the supply voltage correspond to the rated voltage of the motors in delta connections.

Two speed motors

Standard two speed motors are designed for only one rated voltage and for direct starting.

When the speed ratio is 1/2 the standard motors have one winding (Dahlander connection).

For other speed ratios the motors have two different windings.

Connection for single speed motors:

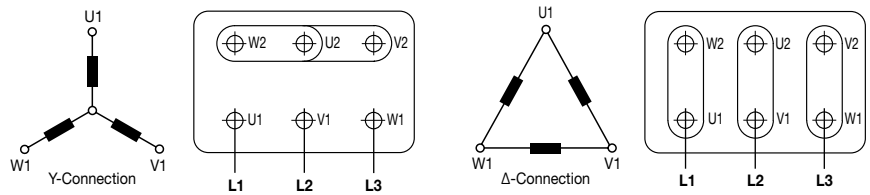

Number of pole: 2, 4, 6, 8

Synchronous speed at 50 Hz: 3000, 1500, 1000, 750

Two separate windings for two speed motors:

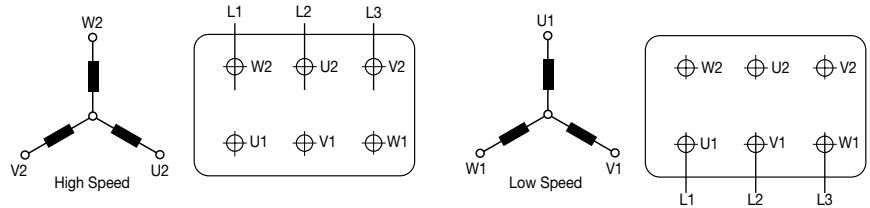

Number of pole: 2/6, 2/8, 4/6, 6/8

Synchronous speed at 50 Hz: 3000/1000, 3000/750, 1500/1000, 1000/750.

Dahlander system for two speed motors:

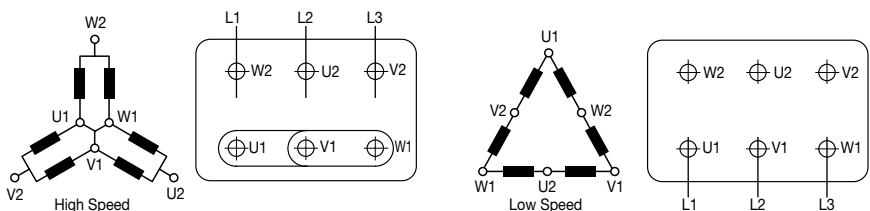

Number of pole: 2/4, 4/8

Synchronous speed at 50 Hz: 3000/1500, 1500/750.

Fig. 30 - Three phase motors connecting diagrams

3.5.2 Single phase motors

Single phase motors are designed for only one rated voltage.

They have two windings (starting and main winding) which have to be connected to the capacitor supplied with the motor.

The sense of rotation can be reversed according to the connecting diagram.

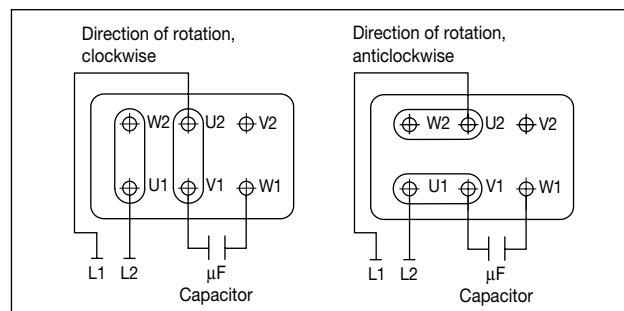

Fig. 3P - Single phase motors connecting diagram

3. Electrical design

3.6 Brake connection diagrams

Other connection diagrams between motor and brake are available, including a single power supply for motor and brake, or power supply on the same terminal board.

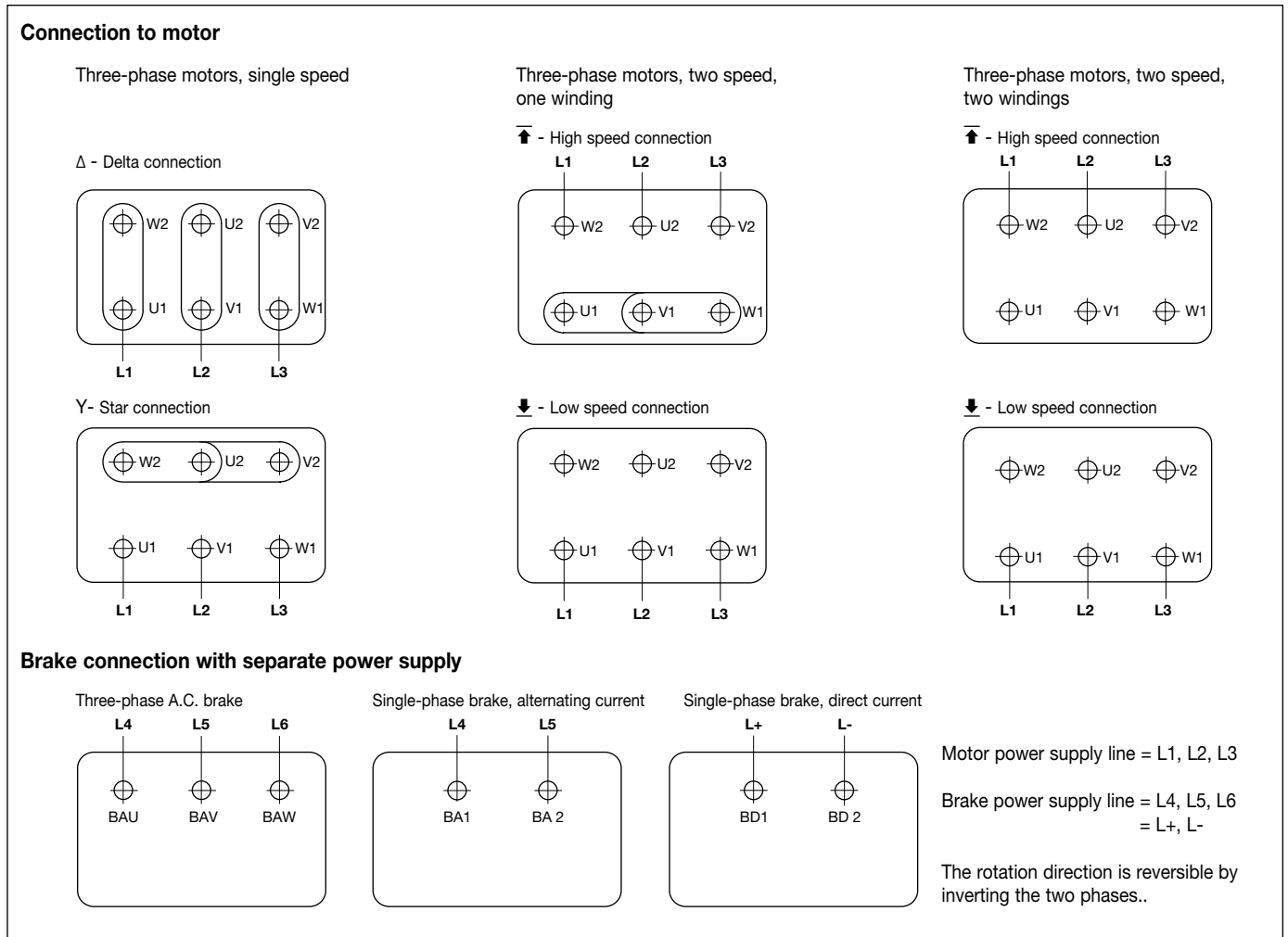

Fig. 3Q - Motor and brake connection diagrams

3.7 Hourly start-ups allowed (Braking: n° per hour)

For motors with intermittent service, (S4) the start-ups per hour allowed depend on the service time and load characteristics, of which inertia is particularly influential. In general, as inertia increases the number of start-ups reduces.

The data given in the column for the “Braking: n° per hour” in section “4. Nominal data” in this catalogue relate to operation with loads that have an inertia 1,5 times that of the motor.

3. Electrical design

3.8 Additional terminals marking (IEC60034-8)

Motors having accessories are supplied with auxiliary terminal boards which bear the marking shown in table 3E.

Table 3E

Marking	No. terminals	Additional terminal for:
TP1 - TP2 (warning)	2	Thermistor PTC (*)
TP3 - TP4 (switch off)	2	
R1 - R2 - R3 (I sensor)	3	Thermistor PT 100 with 3 wires
R4 - R5 - R6 (II sensor)	3	
R7 - R8 - R9 (III sensor)	3	
R11 - R12 - R13 (DE)	3	Thermistor PT 100 on bearing
R21 - R22 - R23 (NDE)	3	
TB1 - TB2 (warning)	2	Normally closed bi-metallic switch (**)
TB3 - TB4 (switch off)	2	
TB8 - TB9 (switch off)	2	Normally closed brake bi-metallic switch (**)
TM1 - TM2 (warning)	2	Normally open bi-metallic switch (**)
TM3 - TM4 (switch off)	2	
HE1- HE2	2	Space heaters
U1 - U2	2	Single phase forced ventilation
U - V - W	2	Three phase forced ventilation
colours according manufacturer diagram	9	Encoder
CA1 - CA2	2	Capacitor
PE	1	Earth cable

(*) U rated = 6V - max 30V - (**) U rated = 250V

3.9 Protection devices

In order to protect the winding of a three-phase induction motor against thermal overloads, resulting in example from overloading and operation with only two phases, one of the following devices can be provided:

- **Bimetallic type device:**

it consists of 2 motor protectors connected in series. The contact is normally closed; the disc opens when the windings temperature reaches limits dangerous for the insulation system. On request, normally open device are available.

- **PTC temperature sensor**

(thermistors):

it consists of 3 sensors connected in series embedded in stator windings. Once it reaches the operating temperature, this device quickly changes the resistance; it must be connected to a suitable releasing device (supplied only on request).

- **PT 100 (RTD) thermometric resistors**

(from size 132 and above).

The resistance value of this device varies according to the windings temperature. They are particularly suitable for a continuous survey of the windings temperature.

For a good survey, at least two sets of PT 100 are requested; they must be connected to their proper monitoring equipment (supplied only on request).

PTC and PT 100 also offer reliable protection for operating modes other than continuous operation, e. g. short-time operation, switching operation, longtime start-up as well as for reduced cooling air flow rates and high ambient temperatures.

Motors for operation with frequency converter are always supplied with PTC thermistor temperature detectors.

Above devices have their proper terminal block located inside main box.

Upon request also available with separate terminal box.

3. Electrical design

3.10 Frequency converter driven motors

Motors with enclosures in protection type “d”, “de” are designed for variable speed drives.

Chapter 4.7 lists the electrical data in different working conditions of the Ex d, Ex de motors shown in this catalogue.

Specific type-approvals are needed for motors with protection type Ex e, while in many countries motors with protection type Ex nA are strongly restricted.

When using a squirrel cage “Ex d” motor with a frequency converter, the following points must be taken into account in addition to the general selection criteria:

- The voltage (or current) fed by the frequency converter is not purely sinusoidal.

As a result it may increase the losses, vibration, and noise of the motor. Furthermore, a change in the distribution of the losses may affect the motor temperature balance.

In every case, the motor must be correctly sized according to the instructions supplied with the selected frequency converter and with our technical data.

- In a frequency converter drive the actual operating speed of the motor may deviate considerably from its rated speed.

For higher speeds it must be ensured that the highest permissible speed of rotation of the motor, or the critical speed of the entire equipment, is not exceeded.

In addition, bearing lubrication and any ventilation noise suppression arrangements will require special attention.

- The torque values shown in this catalogue for motors with constant torque at frequencies over 60Hz can be stably supplied only if the motor has a delta connection.

For example, to stably achieve these values from a 230/400V 50Hz winding motor with a 400V 50Hz mains voltage supply, the motor must have a delta connection and, consequently, the inverter must be configured so that at 50Hz it supplies a voltage of 230V.

Vice-versa, with a star connection, the values listed can be supplied only for very short periods.

- Operating periods at a speed above 3600 1/min must never exceed 10% of the entire work cycle of the motor to ensure the bearings last accordingly.

- If the rated voltage is 500V or if there is a long feeding cable between the motor and the frequency converter, the insulation of the motor must be reinforced because of the occurring voltage peaks.

A correct earthing of the motor and the driven equipment is also important to avoid bearing currents and voltages.

The features of motors for use in constant torque and those for use in quadratic torque are indicated in section 4.7.

Section 7.1 and 7.2 contains graphs showing loading curves for the use of variable torque motors.

The reference torque value (M_n) is the value indicated in the tables in section 4.1.

4. Dati nominali

- 4.1 **Motori trifase, 1 velocità**, dati nominali a 400V 50Hz avviamento diretto
- 4.2 **Motori trifase, 1 velocità IE2**, dati nominali a 400V 50Hz avviamento diretto
- 4.3 **Motori trifase, 2 velocità**, dati nominali a 400V 50Hz avviamento diretto, per uso generale (coppia costante)
- 4.4 **Motori trifase, 2 velocità**, dati nominali a 400V 50Hz avviamento diretto, per macchine centrifughe (coppia quadratica)
- 4.5 **Motori monofase, 1 velocità**, dati nominali a 230V 50Hz avviamento diretto
- 4.6 **Motori trifase con freno, 1 o 2 velocità**, per sollevamento, dati nominali a 400V 50Hz avviamento diretto
- 4.7 **Motori alimentati da inverter**

4. Performance data

- 4.1 *Three-phase motors, 1 speed, rated data at 400V 50Hz direct on line start*
- 4.2 *Three-phase motors, 1 speed IE2 rated data at 400V 50Hz direct on line start*
- 4.3 *Three-phase motors, 2 speeds, rated data at 400V 50Hz direct on line start, for general purpose (constant torque)*
- 4.4 *Three-phase motors, 2 speeds, rated data at 400V 50Hz direct on line start, for centrifugal machines (quadratic torque)*
- 4.5 *Single-phase motors, 1 speed, rated data at 230V 50Hz direct on line start*
- 4.6 *Three-phase motors with brake, 1 or 2 speeds, for hoist applications, rated data at 400V 50Hz direct on line start*
- 4.7 *Motors energized by inverter*

4. Données nominales

- 4.1 **Moteurs triphasés, 1 vitesse**, données nominales à 400V 50Hz démarrage direct
- 4.2 **Moteurs triphasés, 1 vitesse IE2**, données nominales à 400V 50Hz démarrage direct
- 4.3 **Moteurs triphasés, 2 vitesses**, données nominales à 400V 50Hz démarrage direct, pour usage général (couple constant)
- 4.4 **Moteurs triphasés, 2 vitesses**, données nominales à 400V 50Hz démarrage direct, pour machines centrifuges (couple quadratique)
- 4.5 **Moteurs monophasés, 1 vitesse**, données nominales à 230V 50Hz démarrage direct
- 4.6 **Moteurs triphasés avec frein, 1 ou 2 vitesses**, pour levage, données nominales à 400 V 50Hz démarrage direct
- 4.7 **Moteurs alimentés par variateur**

4. Betriebsdaten

- 4.1 *Drehstrom Motoren, 1 Drehzahl, Betriebsdaten bei 400V 50Hz Direkteinschaltung*
- 4.2 *Drehstrom Motoren, 1 Drehzahl IE2, Betriebsdaten bei 400V 50Hz Direkteinschaltung*
- 4.3 *Drehstrom Motoren, 2 Drehzahlen, Betriebsdaten bei 400V 50Hz Direkteinschaltung, für allgemeinen Gebrauch (konstantes Gegenmoment)*
- 4.4 *Drehstrom Motoren, 2 Drehzahlen, Betriebsdaten bei 400V 50Hz Direkteinschaltung, für Zentrifugalmaschinen (quadratisches Gegenmoment)*
- 4.5 *Einphasen Motoren, 1 Drehzahl, Betriebsdaten bei 230V 50Hz Direkteinschaltung*
- 4.6 *Drehstrom Motoren mit Bremse, 1 oder 2 Drehzahlen, Hubmotoren, Betriebsdaten bei 400V 50Hz Direkteinschaltung*
- 4.7 *Motoren mit Umrichterversorgung*

4. Datos nominales

- 4.1 **Motores trifásicos, 1 velocidad**, datos nominales 400V 50Hz arranque directo
- 4.2 **Motores trifásicos, 1 velocidad IE2**, datos nominales 400V 50Hz arranque directo
- 4.3 **Motores trifásicos, 2 velocidades**, datos nominales 400V 50Hz arranque directo, para uso general (par constante)
- 4.4 **Motores trifásicos, 2 velocidades**, datos nominales 400V 50Hz arranque directo, para máquinas centrifugas (par cuadrático)
- 4.5 **Motores monofásicos, 1 velocidad**, datos nominales 230V 50Hz arranque directo
- 4.6 **Motores trifásicos con freno, 1 o 2 velocidades**, para elevación, datos nominales 400V 50Hz arranque directo
- 4.7 **Motores alimentados con inverter**

ITALIANO	4. 4.1	Motori trifase	1	Velocità	3000	giri/min	Freno
ENGLISH		Three-phase motors		Speed		rpm	Brake
FRANÇAIS		Moteurs triphasés		Vitesse		tours/min	Frein
DEUTSCH		Drehstrom Motoren		Drehzahl		U/min	Bremse
ESPAÑOL		Motores trifásicos		Velocidad		rev/min	Freno

Tipo motore	Potenza resa	Velocità	Corrente	Rendimento	Fattore potenza	Coppia	Corrente avviamento	Coppia avviamento	Coppia massima	Rumorosità	Momento d'inerzia	Massa	Massa	Coppia	Potenza	Frenate per ora	Inerzia totale	
Motor type	Rated output	Speed	Current	Efficiency	Power factor	Torque	Starting current	Starting torque	Maximum torque	Noise level	Moment of inertia	Mass	Mass	Torque	Power	Braking: n° per hour	Total inertia	
Moteur type	Puissance mécanique	Vitesse	Intensité	Rendement	Facteur de puissance	Couple	Intensité démarrage	Couple démarrage	Couple maximal	Niveau de bruit	Moment d'inertie	Masse	Masse	Couple	Puissance	Freinages par heure	Inertie totale	
Motor Typ	Leistung	Drehzahl	Strom	Wirkungsgrad	Leistungs-faktor	Moment	Anlaufstrom	Anlauf-moment	Kippmoment	Schalldruck-pegel	Trägheits-moment	Masse	Masse	Moment	Leistung	Bremsungen pro Stunde	Gesamt Trägheit	
Tipo de motor	Potencia proporcionada	Velocidad	Corriente	Rendimiento	Factor de potencia	Par	Corriente de arranque	Par de arranque	Par maximo	Nivel de ruido	Momento de inercia	Peso	Peso	Par	Potencia	Frenados por hora	Inercia total	
	P _n [KW]	n [1/min]	I _n [▷] [A]	η [%]	cos φ	M _n [Nm]	I _a /I _n	M _a /M _n	M _m /M _n	[dB(A)] L _w L _p	J [▼] [kgm ²]	m [kg]	m [kg]	[Nm] S ₁ S ₄	[VA/W]	[max n.]	[kgm ²]	
63 A 2	0.18	2900	0.80	67.0	0.49	0.59	5.0	6.00	6.30	60 52	0.0001	16	22	3	4	40	240	0.00015
63 B 2	0.25	2858	0.85	70.1	0.60	0.84	4.7	4.30	3.70	60 52	0.0001	16	22	3	4	40	240	0.00015
71 A 2	0.37	2770	0.95	69.0	0.83	1.27	4.2	2.60	2.70	66 58	0.0004	19	29	6	9	50	240	0.00082
71 B 2	0.55	2830	1.35	74.9	0.79	1.86	5.3	2.40	2.70	66 58	0.0004	19	29	6	9	50	240	0.00082
80 A 2	0.75	2800	1.84	74.5	0.79	2.56	4.9	2.58	2.90	70 62	0.0006	26	36	12	17	60	240	0.00140
80 B 2	1.10	2845	2.68	77.0	0.77	3.69	5.3	3.00	2.90	70 62	0.0008	26	36	12	17	60	240	0.00160
90 S 2	1.50	2845	3.26	79.0	0.84	5.04	5.4	2.60	2.50	77 69	0.0012	33	52	25	35	140	240	0.00230
90 L 2	2.20	2820	4.53	80.5	0.87	7.44	6.0	2.37	2.95	77 69	0.0015	33	52	25	35	140	240	0.00260
100 LA 2	3.00	2910	6.64	82.5	0.79	9.85	7.5	3.20	3.40	80 72	0.0029	46	62	34	48	180	240	0.00422
112 M 2	4.00	2900	8.00	84.2	0.86	13.17	6.8	2.00	2.50	80 72	0.0074	65	100	50	70	250	240	0.00959
132 SA 2	5.50	2905	10.90	85.0	0.86	18.07	6.5	2.80	2.90	81 73	0.0124	95	124	60	90	400	236	0.01648
132 SB 2	7.50	2925	14.80	86.0	0.85	24.48	6.4	2.51	3.00	83 75	0.0150	95	124	60	90	400	236	0.01908
132 MB 2	9.20	2934	17.30	88.1	0.87	29.95	7.5	2.80	3.00	83 75	0.0178	105	134	60	90	400	236	0.02188
132 ML 2	11.00	2930	21.20	89.3	0.84	35.85	6.6	2.80	3.09	83 75	0.0216	105	134	60	90	400	236	0.02568
160 MA 2	11.00	2930	20.00	89.0	0.89	35.85	6.6	2.50	2.80	84 76	0.0360	180	217	90	130	480	136	0.04101
160 MB 2	15.00	2950	26.80	89.7	0.90	48.56	7.0	2.90	3.00	84 76	0.0463	180	217	90	130	480	136	0.05131
160 L 2	18.50	2930	33.00	89.8	0.90	60.30	7.0	2.80	3.00	84 76	0.0534	195	230	90	130	480	136	0.05841
180 M 2	22.00	2945	39.00	90.6	0.90	71.35	7.5	2.80	2.70	83 74	0.0818	230						
200 LA 2	30.00	2975	54.00	91.6	0.88	96.29	8.5	3.50	2.70	87 77	0.1625	285						
200 LB 2	37.00	2975	65.00	91.8	0.90	118.72	7.9	2.80	2.50	87 77	0.1947	305						
225 M 2	45.00	2975	79.00	92.3	0.89	144.42	9.0	2.60	3.00	89 79	0.2902	385						
250 M 2	55.00	2980	95.00	92.5	0.90	176.24	7.5	2.50	2.80	90 79	0.4197	505						
280 S 2	75.00	2982	134.00	93.2	0.87	240.11	7.5	2.70	3.30	88 76	0.5200	842						
280 M 2	90.00	2985	160.00	93.0	0.88	287.93	9.0	3.10	3.80	88 76	0.6300	881						
315 S 2	110.00	2980	191.40	93.3	0.89	352.40	8.3	3.00	3.30	90 76	0.7000	932						
315 M 2	132.00	2970	228.00	93.0	0.90	424.00	7.9	2.50	3.30	90 76	0.7500	948						
315 LA 2	132.00	2984	222.00	94.0	0.92	422.47	7.0	2.00	2.30	99 85	1.8800	1340						
315 LB 2	160.00	2984	268.50	94.5	0.91	512.21	7.0	1.65	2.00	99 85	2.2500	1430						
315 LC 2	200.00	2980	336.00	94.5	0.91	640.72	7.3	1.70	2.00	99 85	2.7900	1550						

$$I'_n = I_n \cdot \frac{400}{U'} \quad (I'_n = \text{corrente a } U' \text{ Volt});$$

$$(I'_n = \text{current at } U' \text{ Volt});$$

$$(I'_n = \text{intensité à } U' \text{ Volt});$$

$$(I'_n = \text{Strom mit } U' \text{ Volt});$$

$$(I'_n = \text{corriente de } U' \text{ Voltios});$$

$$J = \frac{PD^2}{4}$$

ITALIANO	Motori trifase	Velocità	giri/min	Freno
ENGLISH	Three-phase motors	Speed	rpm	Brake
FRANÇAIS	Moteurs triphasés	Vitesse	tours/min	Frein
DEUTSCH	Drehstrom Motoren	Drehzahl	U/min	Bremse
ESPAÑOL	4.1 Motores trifásicos	1 Velocidad	1500 rev/min	Freno

Tipo motore	Potenza resa	Velocità	Corrente	Rendimento	Fattore potenza	Coppia	Corrente avviamento	Coppia avviamento	Coppia massima	Rumorosità	Momento d'inerzia	Massa	Massa	Coppia	Potenza	Frenate per ora	Inerzia totale
Motor type	Rated output	Speed	Current	Efficiency	Power factor	Torque	Starting current	Starting torque	Maximum torque	Noise level	Moment of inertia	Mass	Mass	Torque	Power	Braking: n° per hour	Total inertia
Moteur type	Puissance mécanique	Vitesse	Intensité	Rendement	Facteur de puissance	Couple	Intensité démarrage	Couple démarrage	Couple maximal	Niveau de bruit	Moment d'inertie	Masse	Masse	Couple	Puissance	Freinages par heure	Inertie totale
Motor Typ	Leistung	Drehzahl	Strom	Wirkungsgrad	Leistungs-faktor	Moment	Anlaufstrom	Anlauf-moment	Kippmoment	Schalldruck-pegel	Trägheits-moment	Masse	Masse	Moment	Leistung	Bremsungen pro Stunde	Gesamt Trägheit
Tipo de motor	Potencia proporcionada	Velocidad	Corriente	Rendimiento	Factor de potencia	Par	Corriente de arranque	Par de arranque	Par maximo	Nivel de ruido	Momento de inercia	Peso	Peso	Par	Potencia	Frenados por hora	Inercia total
	P _n [KW]	n [1/min]	I _n [▷] [A]	η [%]	cos φ	M _n [Nm]	I _a /I _n	M _a /M _n	M _m /M _n	[dB(A)] Lw Lp	J [▼] [kgm ²]	m [kg]	m [kg]	[Nm] S1 S4	[VA/W]	[max n.]	[kgm ²]
63 A 4	0.12	1400	0.62	57.60	0.50	0.82	4.5	3.6	3.80	52 44	0.0002	16	22	3 4	40	240	0.00025
63 B 4	0.18	1340	0.67	61.50	0.62	1.28	4.2	2.3	2.53	52 44	0.0002	16	22	3 4	40	240	0.00025
71 A 4	0.25	1372	0.80	60.00	0.74	1.72	3.0	2.2	2.60	56 48	0.0006	19	29	6 9	50	240	0.00102
71 B 4	0.37	1390	1.10	69.00	0.72	2.53	3.5	2.2	2.76	56 48	0.0009	19	29	6 9	50	240	0.00132
80 A 4	0.55	1380	1.60	69.00	0.71	3.86	4.0	2.3	2.50	59 51	0.0009	26	36	12 17	60	240	0.00170
80 B 4	0.75	1390	2.06	73.00	0.72	5.15	4.0	2.3	2.60	59 51	0.0013	26	36	12 17	60	240	0.00210
90 S 4	1.10	1420	2.80	76.30	0.74	7.38	5.0	2.5	3.00	62 54	0.0020	33	52	25 35	140	240	0.00310
90 L 4	1.50	1400	3.54	77.50	0.79	10.22	5.0	2.3	2.50	62 54	0.0026	33	52	25 35	140	240	0.00370
100 LA 4	2.20	1427	5.15	80.50	0.77	14.72	5.0	2.5	2.60	63 55	0.0043	46	62	34 48	180	240	0.00562
100 LB 4	3.00	1436	7.07	81.70	0.75	19.95	4.8	2.4	3.10	63 55	0.0053	46	62	34 48	180	240	0.00662
112 M 4	4.00	1440	9.01	83.60	0.76	26.49	7.0	2.9	3.20	68 60	0.0103	65	100	50 70	250	240	0.01249
132 SB 4	5.50	1455	11.90	87.00	0.77	36.11	6.3	2.4	2.80	72 64	0.0250	95	134	60 90	400	240	0.02908
132 MB 4	7.50	1460	17.20	86.30	0.73	49.05	5.8	2.7	3.40	75 67	0.0324	95	134	60 90	400	240	0.03648
132 ML 4	8.80	1455	18.50	87.00	0.79	57.77	6.8	2.5	3.51	75 67	0.0405	105	134	60 90	400	240	0.04458
160 MB 4	11.00	1465	22.90	89.00	0.78	71.66	6.2	2.5	3.00	77 69	0.0627	180	217	90 130	480	240	0.06771
160 L 4	15.00	1470	31.40	89.50	0.77	97.42	5.9	2.5	2.99	77 69	0.0801	195	217	90 130	480	240	0.08511
180 M 4	18.50	1470	39.00	89.80	0.76	120.23	6.0	3.2	3.00	79 70	0.1236	230	420	300 400	140	150	0.13560
180 L 4	22.00	1470	44.00	91.00	0.79	142.90	7.0	2.3	2.50	79 70	0.1493	245	435	300 400	140	150	0.16130
200 LB 4	30.00	1470	54.00	91.20	0.88	194.91	6.5	2.5	2.90	82 72	0.2456	305	495	300 400	140	150	0.25760
225 S 4	37.00	1480	69.00	91.70	0.84	238.68	7.1	2.7	3.00	84 73	0.3737	360	710	600 800	140	150	0.38570
225 M 4	45.00	1480	85.00	92.50	0.83	290.30	6.2	2.4	2.80	84 73	0.4479	385	750	600 800	140	150	0.45990
250 M 4	55.00	1485	97.00	92.90	0.88	353.77	7.2	2.9	2.90	86 75	0.7673	540	835	600 800	140	100	0.77930
280 S 4	75.00	1480	136.00	93.00	0.86	483.95	6.3	2.2	2.40	82 70	0.9500	875	1170	600 800	140	100	0.96200
280 M 4	90.00	1485	163.00	93.00	0.86	578.00	7.3	3.0	3.10	82 70	1.1200	901	1196	600 800	140	100	1.13200
315 S 4	110.00	1488	198.50	94.00	0.85	706.40	8.3	3.2	3.49	85 71	1.2700	971	1266	600 800	140	100	1.34200
315 M 4	132.00	1485	242.00	93.00	0.85	848.00	7.1	2.7	2.90	85 71	1.3300	984					
315 LA 4	132.00	1488	240.50	94.10	0.84	847.01	7.2	1.9	1.90	90 76	3.7200	1190					
315 LB 4	160.00	1488	286.50	94.00	0.86	1026.88	7.1	2.0	2.10	90 76	4.1100	1455					
315 LC 4	200.00	1494	364.00	95.00	0.84	1278.43	8.8	2.0	2.10	90 76	5.2100	1640					

▷ I_n = I_n · $\frac{400}{U}$ (I_n = corrente a U' Volt);
(I_n = current at U' Volt);
(I_n = intensité à U' Volt);
(I_n = Strom mit U' Volt);
(I_n = corriente de U' Voltios);

▼ J = $\frac{PD^2}{4}$

ITALIANO	4. 4.1	Motori trifase	1	Velocità	1000	giri/min		Freno
ENGLISH		Three-phase motors		Speed		rpm		Brake
FRANÇAIS		Moteurs triphasés		Vitesse		tours/min		Frein
DEUTSCH		Drehstrom Motoren		Drehzahl		U/min		Bremse
ESPAÑOL		Motores trifásicos		Velocidad		rev/min		Freno

Tipo motore	Potenza resa	Velocità	Corrente	Rendimento	Fattore potenza	Coppia	Corrente avviamento	Coppia avviamento	Coppia massima	Rumorosità	Momento d'inerzia	Massa	Massa	Coppia	Potenza	Frenate per ora	Inerzia totale
Motor type	Rated output	Speed	Current	Efficiency	Power factor	Torque	Starting current	Starting torque	Maximum torque	Noise level	Moment of inertia	Mass	Mass	Torque	Power	Braking: n° per hour	Total inertia
Moteur type	Puissance mécanique	Vitesse	Intensité	Rendement	Facteur de puissance	Couple	Intensité démarrage	Couple démarrage	Couple maximal	Niveau de bruit	Moment d'inertie	Masse	Masse	Couple	Puissance	Freinages par heure	Inertie totale
Motor Typ	Leistung	Drehzahl	Strom	Wirkungsgrad	Leistungs-faktor	Moment	Anlaufstrom	Anlauf-moment	Kippmoment	Schalldruck-pegel	Trägheits-moment	Masse	Masse	Moment	Leistung	Bremsungen pro Stunde	Gesamt Trägheit
Tipo de motor	Potencia proporcionada	Velocidad	Corriente	Rendimiento	Factor de potencia	Par	Corriente de arranque	Par de arranque	Par maximo	Nivel de ruido	Momento de inercia	Peso	Peso	Par	Potencia	Frenados por hora	Inercia total
	P _n [KW]	n [1/min]	I _n [▷] [A]	η [%]	cos φ	M _n [Nm]	I _a /I _n	M _a /M _n	M _m /M _n	[dB(A)] Lw Lp	J [▼] [kgm ²]	m [kg]	m [kg]	[Nm] S1 S4	[VA/W]	[max n.]	[kgm ²]
63 B 6	0.09	850	0.65	38.00	0.52	0.99	2.0	2.3	2.20	48 40	0.0002	16	22	3 4	40	240	0.00025
71 A 6	0.18	945	0.92	55.00	0.51	1.82	3.7	3.7	3.70	50 42	0.0007	19	29	6 9	50	240	0.00112
71 B 6	0.26	918	1.00	60.00	0.63	2.71	3.4	2.6	2.60	50 42	0.0010	19	29	6 9	50	240	0.00142
80 A 6	0.37	930	1.60	58.00	0.58	3.80	3.1	2.9	3.20	53 45	0.0022	26	36	12 17	60	240	0.00300
80 B 6	0.55	930	1.80	70.00	0.65	5.79	2.8	2.0	2.10	53 45	0.0027	26	36	12 17	60	240	0.00350
90 S 6	0.75	910	2.20	70.00	0.71	7.85	3.0	1.8	2.10	54 46	0.0034	33	52	25 35	140	240	0.00450
90 L 6	1.10	935	3.35	73.00	0.65	11.21	3.4	2.0	2.15	54 46	0.0049	33	52	25 35	140	240	0.00600
100 LB 6	1.50	950	3.80	76.00	0.75	15.11	4.2	2.0	2.30	63 55	0.0088	46	62	34 48	180	240	0.01012
112 M 6	2.20	960	6.11	80.00	0.65	21.84	5.2	2.3	2.09	65 57	0.0172	65	100	50 70	250	240	0.01939
132 SB 6	3.00	950	7.50	80.00	0.72	30.16	5.8	1.5	1.68	68 60	0.0323	95	134	60 90	400	240	0.03638
132 MB 6	4.00	970	9.50	81.40	0.75	39.38	6.1	1.7	1.90	68 60	0.0395	95	134	60 90	400	240	0.04358
132 ML 6	5.50	960	12.30	84.00	0.77	54.69	4.7	1.8	2.00	68 60	0.0506	105	134	60 90	400	240	0.05468
160 MB 6	7.50	950	15.70	85.00	0.81	75.33	4.8	2.1	2.14	72 64	0.0919	180	217	90 130	480	240	0.09691
160 L 6	11.00	950	21.50	87.00	0.85	110.57	6.2	1.7	2.00	72 64	0.1218	195	217	90 130	480	240	0.12681
180 L 6	15.00	960	29.00	88.00	0.86	149.20	5.3	2.1	2.73	76 67	0.2263	245	435	300 400	140	150	0.23830
200 LA 6	18.50	975	38.25	90.30	0.77	181.21	5.9	1.6	2.10	79 69	0.2986	295	490	300 400	140	150	0.31060
200 LB 6	22.00	980	45.00	90.50	0.78	214.35	6.0	1.6	1.60	79 69	0.3064	305	515	300 400	140	150	0.31840
225 M 6	30.00	985	61.20	91.00	0.78	290.86	5.8	2.0	2.50	81 70	0.7617	385	750	600 800	140	150	0.77370
250 M 6	37.00	990	73.35	91.80	0.79	356.91	6.7	2.0	2.41	81 70	1.0475	520	813	600 800	140	150	1.05950
250 ML 6	45.00	988	93.60	93.00	0.75	434.60	8.6	3.0	1.9	81 70	1.2300	590	905	600 800	140	150	1.24200
280 S 6	45.00	982	90.50	89.00	0.80	436.29	4.9	2.5	2.80	77 65	1.1400	858	1153	600 800	140	150	1.15200
280 M 6	55.00	980	109.00	91.00	0.81	535.00	4.7	2.3	2.40	77 65	1.3600	894	1189	600 800	140	150	1.37200
315 S 6	75.00	990	151.80	93.20	0.77	722.51	6.1	2.2	2.40	79 65	1.6300	865	1160	600 800	140	150	1.84200
315 M 6	90.00	990	117.10	92.90	0.79	868.13	5.3	1.8	1.80	79 65	1.8300	991					
315 LA 6	90.00	992	171.80	93.00	0.82	865.31	6.8	1.7	1.85	84 70	5.7300	1370					
315 LB 6	110.00	992	184.50	94.00	0.91	1058.91	8.6	1.2	1.70	84 70	5.9400	1450					
315 LC 6	132.00	995	243.00	94.00	0.83	1264.00	5.3	2.1	2.10	84 70	8.4500	1520					

$$I'_n = I_n \cdot \frac{400}{U'} \quad (I'_n = \text{corrente a } U' \text{ Volt});$$

$$(I'_n = \text{current at } U' \text{ Volt});$$

$$(I'_n = \text{intensité à } U' \text{ Volt});$$

$$(I'_n = \text{Strom mit } U' \text{ Volt});$$

$$(I'_n = \text{corriente de } U' \text{ Voltios});$$

$$J = \frac{PD^2}{4}$$

ITALIANO	4. 4.1	Motori trifase	1	Velocità	750	giri/min		Freno
ENGLISH		Three-phase motors		Speed		rpm		Brake
FRANÇAIS		Moteurs triphasés		Vitesse		tours/min		Frein
DEUTSCH		Drehstrom Motoren		Drehzahl		U/min		Bremse
ESPAÑOL		Motores trifásicos		Velocidad		rev/min		Freno

Tipo motore	Potenza resa	Velocità	Corrente	Rendimento	Fattore potenza	Coppia	Corrente avviamento	Coppia avviamento	Coppia massima	Rumorosità	Momento d'inerzia	Massa	Massa	Coppia	Potenza	Frenate per ora	Inerzia totale	
Motor type	Rated output	Speed	Current	Efficiency	Power factor	Torque	Starting current	Starting torque	Maximum torque	Noise level	Moment of inertia	Mass	Mass	Torque	Power	Braking: n° per hour	Total inertia	
Moteur type	Puissance mécanique	Vitesse	Intensité	Rendement	Facteur de puissance	Couple	Intensité démarrage	Couple démarrage	Couple maximal	Niveau de bruit	Moment d'inertie	Masse	Masse	Couple	Puissance	Freinages par heure	Inertie totale	
Motor Typ	Leistung	Drehzahl	Strom	Wirkungsgrad	Leistungs-faktor	Moment	Anlaufstrom	Anlauf-moment	Kippmoment	Schalldruck-pegel	Trägheits-moment	Masse	Masse	Moment	Leistung	Bremsungen pro Stunde	Gesamt Trägheit	
Tipo de motor	Potencia proporcionada	Velocidad	Corriente	Rendimiento	Factor de potencia	Par	Corriente de arranque	Par de arranque	Par maximo	Nivel de ruido	Momento de inercia	Peso	Peso	Par	Potencia	Frenados por hora	Inercia total	
	P _n [KW]	n [1/min]	I _n [▷] [A]	η [%]	cos φ	M _n [Nm]	I _a /I _n	M _a /M _n	M _m /M _n	[dB(A)] Lw Lp	J [▼] [kgm ²]	m [kg]	m [kg]	[Nm] S1 S4	[VA/W]	[max n.]	[kgm ²]	
63 B 8	0.05	590	0.44	27.00	0.60	0.79	1.60	1.6	1.8	47 39	0.0002	16	22	3	4	40	240	0.00025
71 B 8	0.15	600	0.57	54.00	0.75	2.54	2.10	1.3	1.5	48 40	0.0010	19	29	6	9	50	240	0.00142
80 A 8	0.18	707	1.00	51.00	0.51	2.43	3.10	1.9	2.0	49 41	0.0022	26	36	12	17	60	240	0.00300
80 B 8	0.25	690	1.00	61.00	0.60	3.53	3.30	1.4	1.7	49 41	0.0027	26	36	12	17	60	240	0.00350
90 S 8	0.37	680	1.30	75.00	0.55	5.20	2.20	1.5	1.8	53 45	0.0034	33	52	25	35	140	240	0.00450
90 L 8	0.55	680	1.90	80.00	0.52	7.73	2.10	1.5	1.8	53 45	0.0049	33	52	25	35	140	240	0.00600
100 LA 8	0.75	700	2.85	67.50	0.57	10.20	2.60	2.0	2.2	60 52	0.0088	46	62	34	48	180	240	0.01012
100 LB 8	1.10	675	3.10	75.00	0.68	15.50	2.70	1.8	2.2	60 52	0.0088	46	62	34	48	180	240	0.01012
112 M 8	1.50	720	4.40	76.00	0.65	20.00	4.10	1.9	2.2	62 54	0.0172	65	100	50	70	250	240	0.01939
132 SB 8	2.20	720	6.50	75.00	0.66	29.20	4.00	1.8	2.3	66 58	0.0323	95	134	60	90	400	240	0.03638
132 MB 8	3.00	720	8.50	82.00	0.63	40.25	3.90	1.7	2.3	66 58	0.0506	105	134	60	90	400	240	0.05468
160 MA 8	4.00	718	9.70	85.00	0.70	53.20	4.50	2.3	2.6	70 62	0.0919	180	217	90	130	480	240	0.09691
160 MB 8	5.50	725	14.00	76.00	0.77	73.00	3.90	2.2	2.5	70 62	0.0919	180	217	90	130	480	240	0.09691
160 L 8	7.50	720	18.00	80.00	0.77	99.50	4.20	2.4	2.8	70 62	0.1218	195	217	90	130	480	240	0.12681
180 L 8	11.00	720	23.00	87.40	0.79	146.40	5.70	2.2	2.4	73 64	0.2791	245	435	300	400	140	150	0.29110
200 LB 8	15.00	735	35.00	89.00	0.70	196.00	5.30	1.6	2.1	75 65	0.4595	305	495	300	400	140	150	0.47150
225 S 8	18.50	735	42.25	88.00	0.72	240.33	5.80	2.4	2.7	79 68	0.6337	360	710	600	800	140	150	0.64570
225 M 8	22.00	730	46.00	88.00	0.79	288.00	5.00	2.1	2.3	79 68	0.7617	385	750	600	800	140	150	0.77370
250 M 8	30.00	740	61.00	94.00	0.76	386.90	6.20	1.8	2.2	79 68	1.2961	550	840	600	800	140	150	1.30810
280 S 8	37.00	730	71.00	90.00	0.86	492.30	5.50	1.9	2.5	72 60	1.5100	875	1170	600	800	140	150	1.52200
280 M 8	45.00	739	83.00	94.00	0.83	581.53	5.30	1.4	1.9	72 60	1.7900	901	1196	600	800	140	150	1.80200
315 S 8	55.00	742	115.00	93.00	0.74	707.88	8.70	2.7	2.9	75 61	1.9900	965	1260	600	800	140	150	2.19200
315 M 8	75.00	735	142.00	93.00	0.82	971.00	7.00	2.0	2.5	75 61	2.1800	991						
315 LA 8	55.00	740	117.10	93.20	0.77	709.53	6.60	1.7	2.0	77 63	5.7300	1330						
315 LB 8	90.00	744	164.50	95.00	0.84	1164.00	6.40	1.7	2.5	77 63	6.9400	1470						
315 LC 8	110.00	743	202.00	94.00	0.84	1414.00	6.40	1.7	2.7	77 63	8.4500	1590						

$$I_n = I_n \cdot \frac{400}{U} \quad (I_n = \text{corrente a } U' \text{ Volt};$$

$$(I_n = \text{current at } U' \text{ Volt};$$

$$(I_n = \text{intensité à } U' \text{ Volt};$$

$$(I_n = \text{Strom mit } U' \text{ Volt};$$

$$(I_n = \text{corriente de } U' \text{ Voltios);}$$

$$J = \frac{PD^2}{4}$$

ITALIANO	4.	Motori trifase IE2	Velocità	giri/min
ENGLISH	4.2	Three-phase motors IE2	Speed	rpm
FRANÇAIS		Moteurs triphasés IE2	Vitesse	tours/min
DEUTSCH		Drehstrom Motoren IE2	Drehzahl	U/min
ESPAÑOL		Motores trifásicos IE2	Velocidad	3000 rev/min

Tipo motore	Potenza resa	Velocità	Corrente	Rendimento	Fattore potenza	Coppia	Corrente avviamento	Coppia avviamento	Coppia massima	Rumorosità	Momento d'inerzia	Massa				
Motor type	Rated output	Speed	Current	Efficiency	Power factor	Torque	Starting current	Starting torque	Maximum torque	Noise level	Moment of inertia	Mass				
Moteur type	Puissance mécanique	Vitesse	Intensité	Rendement	Facteur de puissance	Couple	Intensité démarrage	Couple démarrage	Couple maximal	Niveau de bruit	Moment d'inertie	Masse				
Motor Typ	Leistung	Drehzahl	Strom	Wirkungsgrad	Leistungs-faktor	Moment	Anlaufstrom	Anlauf-moment	Kippmoment	Schalldruck-pegel	Trägheits-moment	Masse				
Tipo de motor	Potencia proporcionada	Velocidad	Corriente	Rendimiento	Factor de potencia	Par	Corriente de arranque	Par de arranque	Par maximo	Nivel de ruido	Momento de inercia	Peso				
	P _n [KW]	n [1/min]	I _n ^P [A]	η [%]	cos φ	M _n [Nm]	I _a /I _n	M _a /M _n	M _m /M _n	[dB(A)] Lw Lp	J [▼] [kgm ²]	m [kg]				
80 A 2	0.75	2847	1.80	77.4	0.78	2.52	5.7	2.40	2.60	70 62	0.0006	26				
80 B 2	1.10	2830	2.50	79.6	0.80	3.71	5.8	3.65	2.50	70 62	0.0008	26				
90 S 2	1.50	2880	3.30	81.3	0.81	4.97	6.4	2.70	2.60	77 69	0.0012	33				
90 L 2	2.20	2880	4.80	83.2	0.80	7.29	7.1	3.20	4.00	77 69	0.0015	33				
100 LA 2	3.00	2905	6.45	84.6	0.79	9.85	7.8	3.20	3.40	80 72	0.0029	46				
112 M 2	4.00	2900	7.75	85.8	0.87	13.16	7.6	2.70	3.40	80 72	0.0074	65				
132 SA 2	5.50	2920	10.55	87.0	0.87	17.98	7.2	2.80	2.90	81 73	0.0124	95				
132 SB 2	7.50	2920	14.45	88.1	0.85	24.51	7.3	3.00	3.60	83 75	0.0150	95				
160 MA 2	11.00	2935	19.90	89.4	0.89	35.79	6.9	3.40	3.80	84 76	0.0360	180				
160 MB 2	15.00	2945	26.65	90.3	0.90	48.62	7.6	3.40	3.50	84 76	0.0463	180				
160 L 2	18.50	2930	32.30	90.9	0.91	60.24	5.5	3.00	3.20	84 76	0.0534	195				
180 M 2	22.00	2952	38.30	91.3	0.90	71.15	9.2	3.00	2.90	83 74	0.0818	230				
200 LA 2	30.00	2970	51.25	92.0	0.92	96.42	9.3	3.70	2.95	87 77	0.1625	285				
200 LB 2	37.00	2960	62.50	92.5	0.93	119.30	9.4	2.20	1.95	87 77	0.1947	605				
225 M 2	45.00	2973	76.95	92.9	0.91	144.57	8.1	2.10	2.30	89 79	0.2902	385				
250 M 2	55.00	2975	95.20	93.2	0.90	176.64	8.6	2.50	2.80	90 79	0.4197	505				
280 S 2	75.00	2978	128.90	93.8	0.90	240.49	8.0	2.30	2.50	88 76	0.5200	842				
280 M 2	90.00	2984	157.70	94.1	0.88	287.93	8.1	3.10	3.30	88 76	0.6300	881				
315 S 2	110.00	2980	189.10	94.3	0.89	352.50	6.7	1.80	2.00	90 76	0.7000	932				
315 LA 2	132.00	2983	218.90	94.6	0.92	422.44	7.2	2.00	2.20	99 85	1.8800	1340				
315 LB 2	160.00	2984	267.70	94.8	0.91	516.06	7.0	1.70	2.10	99 85	2.2500	1430				
315 LC 2	200.00	2980	333.70	95.0	0.91	640.70	7.5	1.70	1.90	99 85	2.7900	1550				

$$I'_n = I_n \cdot \frac{400}{U'} \quad (I'_n = \text{corrente a } U' \text{ Volt});$$

$$(I'_n = \text{current at } U' \text{ Volt});$$

$$(I'_n = \text{intensité à } U' \text{ Volt});$$

$$(I'_n = \text{Strom mit } U' \text{ Volt});$$

$$(I'_n = \text{corriente de } U' \text{ Voltios});$$

$$J = \frac{PD^2}{4}$$

ITALIANO	Motori trifase IE2	Velocità	giri/min
ENGLISH	Three-phase motors IE2	Speed	rpm
FRANÇAIS	Moteurs triphasés IE2	Vitesse	tours/min
DEUTSCH	4. Drehstrom Motoren IE2	Drehzahl	U/min
ESPAÑOL	4.2 Motores trifásicos IE2	1 Velocidad	1500 rev/min

Tipo motore	Potenza resa	Velocità	Corrente	Rendimento	Fattore potenza	Coppia	Corrente avviamento	Coppia avviamento	Coppia massima	Rumorosità	Momento d'inerzia	Massa				
Motor type	Rated output	Speed	Current	Efficiency	Power factor	Torque	Starting current	Starting torque	Maximum torque	Noise level	Moment of inertia	Mass				
Moteur type	Puissance mécanique	Vitesse	Intensité	Rendement	Facteur de puissance	Couple	Intensité démarrage	Couple démarrage	Couple maximal	Niveau de bruit	Moment d'inertie	Masse				
Motor Typ	Leistung	Drehzahl	Strom	Wirkungsgrad	Leistungs-faktor	Moment	Anlaufstrom	Anlauf-moment	Kippmoment	Schalldruck-pegel	Trägheits-moment	Masse				
Tipo de motor	Potencia proporcionada	Velocidad	Corriente	Rendimiento	Factor de potencia	Par	Corriente de arranque	Par de arranque	Par maximo	Nivel de ruido	Momento de inercia	Peso				
	P _n [KW]	n [1/min]	I _n ^P [A]	η [%]	cos φ	M _n [Nm]	I _a /I _n	M _a /M _n	M _m /M _n	[dB(A)] Lw Lp	J [▼] [kgm ²]	m [kg]				
80 B 4	0.75	1430	2.05	79.6	0.67	5.01	5.4	3.00	3.20	59 51	0.0013	26				
90 S 4	1.10	1430	2.70	81.4	0.73	7.34	5.8	3.30	3.60	62 54	0.0020	33				
90 L 4	1.50	1430	3.75	82.8	0.72	10.02	6.4	3.70	4.40	62 54	0.0026	33				
100 LA 4	2.20	1450	5.20	84.3	0.72	14.47	7.1	2.50	3.10	63 55	0.0043	46				
100 LB 4	3.00	1450	6.70	85.5	0.76	19.98	6.6	3.00	3.30	63 55	0.0053	46				
112 M 4	4.00	1435	8.80	86.6	0.76	26.35	7.4	3.50	4.00	68 60	0.0103	65				
132 SB 4	5.50	1450	11.70	87.7	0.78	36.37	5.1	2.20	2.70	72 64	0.0250	95				
132 MB 4	7.50	1444	14.65	88.7	0.83	49.59	5.9	3.10	3.40	75 67	0.0324	95				
160 MB 4	11.00	1444	23.10	89.8	0.77	71.57	6.0	2.30	3.00	77 69	0.0627	180				
160 L 4	15.00	1468	30.50	90.6	0.79	97.63	6.6	2.70	3.00	77 69	0.0801	195				
180 M 4	18.50	1465	36.65	91.2	0.80	120.17	7.3	3.10	3.60	79 70	0.1236	230				
180 L 4	22.00	1470	42.20	91.6	0.82	142.89	8.4	3.48	4.40	79 70	0.1493	245				
200 LB 4	30.00	1470	53.30	92.3	0.88	194.44	7.7	1.80	2.50	82 72	0.2456	305				
225 S 4	37.00	1472	66.40	92.7	0.87	239.79	6.0	2.00	2.40	84 73	0.3737	360				
225 M 4	45.00	1474	80.60	93.1	0.87	290.87	6.8	2.10	2.50	84 73	0.4479	385				
250 M 4	55.00	1475	96.50	93.5	0.88	353.69	7.3	2.90	2.70	86 75	0.7673	540				
280 S 4	75.00	1485	134.90	94.0	0.85	483.80	6.5	2.70	2.90	82 70	0.9500	875				
280 M 4	90.00	1480	160.40	94.2	0.86	577.60	7.5	3.00	3.50	82 70	1.1200	901				
315 S 4	110.00	1487	198.00	94.5	0.85	706.40	8.3	3.20	3.60	85 71	1.2700	971				
315 LA 4	132.00	1488	239.00	94.7	0.84	847.01	7.2	1.90	2.20	90 76	3.7200	1190				
315 LB 4	160.00	1488	283.00	94.9	0.86	1026.88	7.1	2.00	2.00	90 76	4.1100	1455				
315 LC 4	200.00	1494	361.00	95.1	0.84	1278.43	8.8	2.00	2.20	90 76	5.2100	1640				

$$I'_n = I_n \cdot \frac{400}{U'} \quad (I'_n = \text{corrente a } U' \text{ Volt});$$

$$(I'_n = \text{current at } U' \text{ Volt});$$

$$(I'_n = \text{intensité à } U' \text{ Volt});$$

$$(I'_n = \text{Strom mit } U' \text{ Volt});$$

$$(I'_n = \text{corriente de } U' \text{ Voltios});$$

$$J = \frac{PD^2}{4}$$

ITALIANO	Motori trifase IE2	Velocità	giri/min
ENGLISH	Three-phase motors IE2	Speed	rpm
FRANÇAIS	Moteurs triphasés IE2	Vitesse	tours/min
DEUTSCH	4. Drehstrom Motoren IE2	Drehzahl	U/min
ESPAÑOL	4.2 Motores trifásicos IE2	1 Velocidad	1000 rev/min

Tipo motore	Potenza resa	Velocità	Corrente	Rendimento	Fattore potenza	Coppia	Corrente avviamento	Coppia avviamento	Coppia massima	Rumorosità	Momento d'inerzia	Massa				
Motor type	Rated output	Speed	Current	Efficiency	Power factor	Torque	Starting current	Starting torque	Maximum torque	Noise level	Moment of inertia	Mass				
Moteur type	Puissance mécanique	Vitesse	Intensité	Rendement	Facteur de puissance	Couple	Intensité démarrage	Couple démarrage	Couple maximal	Niveau de bruit	Moment d'inertie	Masse				
Motor Typ	Leistung	Drehzahl	Strom	Wirkungsgrad	Leistungs-faktor	Moment	Anlaufstrom	Anlauf-moment	Kippmoment	Schalldruck-pegel	Trägheits-moment	Masse				
Tipo de motor	Potencia proporcionada	Velocidad	Corriente	Rendimiento	Factor de potencia	Par	Corriente de arranque	Par de arranque	Par maximo	Nivel de ruido	Momento de inercia	Peso				
	P _n [KW]	n [1/min]	I _n ^P [A]	η [%]	cos φ	M _n [Nm]	I _a /I _n	M _a /M _n	M _m /M _n	[dB(A)] Lw Lp	J [▼] [kgm ²]	m [kg]				
90 S 6	0.75	955	2.38	75.9	0.60	7.50	5.0	2.50	2.80	54 46	0.0034	33				
90 L 6	1.10	920	2.95	78.1	0.69	11.41	3.4	2.00	2.30	54 46	0.0049	33				
100 LB 6	1.50	948	3.85	79.8	0.71	15.11	4.2	2.00	2.20	63 55	0.0088	46				
112 M 6	2.20	964	5.60	81.8	0.69	21.79	6.1	2.40	2.80	65 67	0.0172	65				
132 SB 6	3.00	960	7.32	83.3	0.71	29.84	5.8	2.00	2.20	68 60	0.0323	95				
132 MB 6	4.00	960	9.10	84.6	0.72	39.67	5.7	2.00	2.20	68 60	0.0395	95				
132 ML 6	5.50	968	13.25	86.0	0.70	54.27	6.0	2.90	3.20	68 60	0.0506	105				
160 MB 6	7.50	970	16.20	87.2	0.77	73.94	6.5	3.00	3.30	72 64	0.0919	180				
160 L 6	11.00	965	22.95	88.7	0.78	108.86	6.5	2.30	2.50	72 64	0.1218	195				
180 L 6	15.00	975	31.45	89.7	0.77	146.85	7.2	2.50	3.00	76 67	0.2263	245				
200 LA 6	18.50	980	39.38	90.4	0.75	180.28	6.5	1.80	1.90	79 69	0.2986	295				
200 LB 6	22.00	985	47.85	90.9	0.73	213.30	7.5	2.30	2.60	79 69	0.3064	305				
225 M 6	30.00	985	62.96	91.7	0.75	290.86	7.0	2.80	3.20	81 70	0.7617	385				
250 M 6	37.00	985	71.10	92.2	0.82	358.43	7.0	2.00	2.40	81 70	1.0475	520				
280 S 6	45.00	982	87.58	92.7	0.80	437.63	4.9	2.50	2.80	77 65	1.1400	858				
280 M 6	55.00	985	109.32	93.1	0.78	533.25	5.2	2.30	2.40	77 65	1.3600	894				
315 S 6	75.00	990	150.04	93.7	0.77	723.48	6.1	2.20	2.40	79 65	1.6300	865				
315 LA 6	90.00	992	172.74	94.0	0.80	866.43	6.8	1.70	1.85	84 70	5.7300	1370				
315 LB 6	110.00	992	185.02	94.3	0.91	1058.97	8.6	1.20	1.70	84 70	5.9400	1450				
315 LC 6	132.00	995	236.94	94.6	0.85	1266.93	6.3	1.90	2.00	84 70	8.4500	1520				

$$I_n^P = I_n \cdot \frac{400}{U}$$

(I_n = corrente a U' Volt);
(I_n = current at U' Volt);
(I_n = intensité à U' Volt);
(I_n = Strom mit U' Volt);
(I_n = corriente de U' Voltios);

$$J = \frac{PD^2}{4}$$

ITALIANO	Motori trifase	Velocità	giri/min	per uso generale - 1 avvolgimento Dahlander	Freno
ENGLISH	Three-phase motors	Speeds	rpm	for general purpose - 1 winding Dahlander	Brake
FRANÇAIS	Moteurs triphasés	Vitesses	tours/min	pour usage général - 1 enroulement Dahlander	Frein
DEUTSCH	4. Drehstrom Motoren	Drehzahlen	3000 U/min	für allgemeinen Gebrauch - 1 Wicklung Dahlander	Bremse
ESPAÑOL	4.3 Motores trifásicos	2 Velocidades	1500 rev/min	para uso general - 1 devanado Dahlander	Freno

Tipo motore	Potenza resa	Velocità	Corrente	Rendimento	Fattore potenza	Coppia	Corrente avviamento	Coppia avviamento	Rumorosità	Momento d'inerzia	Massa	Massa	Coppia	Potenza	Frenate per ora	Inerzia totale	
Motor type	Rated output	Speed	Current	Efficiency	Power factor	Torque	Starting current	Starting torque	Noise level	Moment of inertia	Mass	Mass	Torque	Power	Braking: n° per hour	Total inertia	
Moteur type	Puissance mécanique	Vitesse	Intensité	Rendement	Facteur de puissance	Couple	Intensité démarrage	Couple démarrage	Niveau de bruit	Moment d'inertie	Masse	Masse	Couple	Puissance	Freinages par heure	Inertie totale	
Motor Typ	Leistung	Drehzahl	Strom	Wirkungsgrad	Leistungs-faktor	Moment	Anlaufstrom	Anlauf-moment	Schalldruck-pegel	Trägheits-moment	Masse	Masse	Moment	Leistung	Bremsungen pro Stunde	Gesamt Trägheit	
Tipo de motor	Potencia proporcionada	Velocidad	Corriente	Rendimiento	Factor de potencia	Par	Corriente de arranque	Par de arranque	Nivel de ruido	Momento de inercia	Peso	Peso	Par	Potencia	Frenados por hora	Inercia total	
	P _n [KW]	n [1/min]	I _n [▷] [A]	η [%]	cos φ	M _n [Nm]	I _a /I _n	M _a /M _n	[dB(A)] L _w L _p	J [▼] [kgm ²]	m [kg]	m [kg]	[Nm] S1 S4	[VA/W]	[max n.]	[kgm ²]	
63 B 24	0.20 0.15	2740 1310	0.52 0.59	68 49	0.83 0.74	0.7 1.1	3.5 2.2	1.9 1.6	60 52	0.0002	16	22	3	4	40	240	0.00015
71 A 24	0.30 0.20	2820 1360	0.86 0.76	71 54	0.71 0.70	1.0 1.4	3.7 3.8	1.7 1.5	66 58	0.0006	19	29	6	9	50	240	0.00082
71 B 24	0.45 0.30	2805 1420	1.26 1.20	62 59	0.83 0.63	1.5 2.0	4.6 3.4	2.5 2.3	66 58	0.0009	19	29	6	9	50	240	0.00082
80 A 24	0.60 0.45	2800 1400	1.60 1.20	68 69	0.87 0.84	2.1 3.1	4.9 4.7	2.8 2.3	70 62	0.0009	26	36	12	17	60	240	0.00140
80 B 24	0.80 0.60	2800 1400	2.10 1.70	64 72	0.85 0.71	2.7 4.1	4.4 4.1	1.8 1.7	70 62	0.0013	26	36	12	17	60	240	0.00160
90 S 24	1.25 0.90	2780 1380	2.90 2.40	65 64	0.96 0.85	4.3 6.2	5.5 4.6	2.0 1.8	77 69	0.0020	33	52	25	35	140	240	0.00230
90 L 24	1.60 1.20	2850 1410	3.70 3.10	71 73	0.90 0.77	5.4 8.1	5.1 4.5	2.4 2.3	77 69	0.0026	33	52	25	35	140	240	0.00260
100 M 24	2.35 1.85	2780 1400	5.40 4.50	70 72	0.90 0.82	8.1 12.6	6.5 5.4	2.4 2.1	80 72	0.0043	46	62	34	48	180	240	0.00562
100 L 24	3.00 2.40	2880 1420	7.30 5.70	73 79	0.77 0.77	10.0 16.1	6.6 5.2	2.6 2.4	80 72	0.0053	46	62	34	48	180	240	0.00662
112 M 24	4.00 3.30	2860 1450	8.60 6.80	84 65	0.80 0.80	13.4 21.7	7.0 6.2	2.3 2.2	80 72	0.0103	65	100	50	70	250	240	0.00959
132 S 24	5.90 4.80	2880 1430	11.50 10.00	80 81	0.93 0.85	19.6 32.1	7.2 6.4	2.2 2.1	83 75	0.0150	95	124	60	90	400	236	0.01648
132 MB 24	7.50 5.50	2880 1430	14.50 13.50	88 73	0.85 0.80	24.9 36.8	8.9 7.2	2.2 2.1	83 75	0.0178	95	134	60	90	400	236	0.02188
132 L 24	8.00 6.00	2890 1440	19.00 17.00	72 63	0.85 0.80	26.5 39.3	7.5 6.3	2.3 2.2	83 75	0.0216	105	134	60	90	400	236	0.02578
160 M 24	11.00 8.80	2940 1440	22.00 22.00	80 78	0.90 0.74	35.7 58.4	7.3 6.5	2.3 2.1	84 76	0.0627	180	217	90	130	480	136	0.04101
160 L 24	15.00 12.00	2945 1450	29.50 28.50	77 81	0.95 0.75	48.6 79.0	7.5 6.6	2.4 2.3	84 76	0.0801	195	230	90	130	480	136	0.05841
180 M 24	18.50 15.00	2930 1460	36.00 29.50	82 83	0.90 0.88	60.3 98.1	6.4 5.6	2.1 2.0	83 74	0.1270	230						
180 L 24	22.00 18.50	2960 1465	42.60 38.00	89 90	0.84 0.78	71.2 121.1	6.6 5.8	2.2 2.1	83 74	0.1488	245						
200 LB 24	30.00 24.00	2970 1480	54.60 44.60	90 93	0.88 0.84	97.3 156.5	7.7 3.9	2.2 2.5	87 77	0.2436	315						
225 S 24	33.00 30.00	2955 1475	66.00 55.00	80 91	0.90 0.87	106.6 194.2	6.8 6.2	2.2 2.1	89 79	0.3762	355						
225 M 24	40.00 37.00	2965 1480	77.00 69.00	82 88	0.92 0.88	128.8 238.7	6.8 6.2	2.2 2.2	89 79	0.4451	380						
250 M 24	50.00 45.00	2970 1475	92.00 84.00	88 89	0.89 0.87	160.8 291.3	6.9 6.4	2.1 2.3	90 79	0.4611	450						
280 S 24	66.00 52.00	2950 1480	123.30 102.80	91 85	0.85 0.86	200.7 238.8	9.4 8.2	2.8 2.7	88 76	0.5200	875						
280 M 24	79.00 60.00	2950 1480	145.90 122.90	91 84	0.86 0.84	242.8 290.4	9.2 8.0	2.8 2.6	88 76	0.6300	901						
315 S 24	90.00 70.00	2955 1485	166.10 133.80	89 90	0.88 0.84	323.2 334.4	9.4 8.0	2.9 2.9	90 76	0.7000	971						
315 M 24	95.00 75.00	2965 1485	173.30 140.10	89 91	0.89 0.85	347.9 353.7	9.5 8.1	2.9 2.8	90 76	0.7500	984						
315 LA 24	○	○	○	○	○	○	○	○	○	○	○						
315 LB 24	○	○	○	○	○	○	○	○	○	○	○						
315 LC 24	○	○	○	○	○	○	○	○	○	○	○						

○ I dati non indicati sono forniti su richiesta
 Data not indicated is supplied on request
 Les données qui ne sont pas indiquées sont fournies sur demande
 Die nicht angegebenen Daten werden auf Anfrage geliefert
 Los datos que no se han precisado se pueden comunicar cuando se solicite

$$I'_n = I_n \cdot \frac{400}{U'} \quad (I'_n = \text{corrente a } U' \text{ Volt});$$

$$(I'_n = \text{current at } U' \text{ Volt});$$

$$(I'_n = \text{intensité à } U' \text{ Volt});$$

$$(I'_n = \text{Strom mit } U' \text{ Volt});$$

$$(I'_n = \text{corriente de } U' \text{ Voltios});$$

$$J = \frac{PD^2}{4}$$

ITALIANO	Motori trifase	Velocità	giri/min	per uso generale - 1 avvolgimento Dahlander	Freno
ENGLISH	Three-phase motors	Speeds	rpm	for general purpose - 1 winding Dahlander	Brake
FRANÇAIS	Moteurs triphasés	Vitesse	tours/min	pour usage général - 1 enroulement Dahlander	Frein
DEUTSCH	4. Drehstrom Motoren	Drehzahlen	1500 U/min	für allgemeinen Gebrauch - 1 Wicklung Dahlander	Bremse
ESPAÑOL	4.3 Motores trifásicos	2 Velocidades	750 rev/min	para uso general - 1 devanado Dahlander	Freno

Tipo motore	Potenza resa	Velocità	Corrente	Rendimento	Fattore potenza	Coppia	Corrente avviamento	Coppia avviamento		Rumorosità	Momento d'inerzia	Massa	Massa	Coppia	Potenza	Frenate per ora	Inerzia totale
Motor type	Rated output	Speed	Current	Efficiency	Power factor	Torque	Starting current	Starting torque		Noise level	Moment of inertia	Mass	Mass	Torque	Power	Braking: n° per hour	Total inertia
Moteur type	Puissance mécanique	Vitesse	Intensité	Rendement	Facteur de puissance	Couple	Intensité démarrage	Couple démarrage		Niveau de bruit	Moment d'inertie	Masse	Masse	Couple	Puissance	Freinages par heure	Inertie totale
Motor Typ	Leistung	Drehzahl	Strom	Wirkungsgrad	Leistungs-faktor	Moment	Anlaufstrom	Anlauf-moment		Schalldruck-pegel	Trägheits-moment	Masse	Masse	Moment	Leistung	Bremsungen pro Stunde	Gesamt Trägheit
Tipo de motor	Potencia proporcionada	Velocidad	Corriente	Rendimiento	Factor de potencia	Par	Corriente de arranque	Par de arranque		Nivel de ruido	Momento de inercia	Peso	Peso	Par	Potencia	Frenados por hora	Inercia total
	P _n [KW]	n [1/min]	I _n [▷] [A]	η [%]	cos φ	M _n [Nm]	I _a /I _n	M _a /M _n		[dB(A)] L _w L _p	J [▼] [kgm ²]	m [kg]	m [kg]	[Nm] S1 S4	[VA/W]	[max n.]	[kgm ²]
71 A 48	0.17	1330	0.57	74	0.58	1.2	3.2	1.5		56 48	0.0007	19	29	3 9	50	240	0.00102
	0.09	670	0.48	48	0.57	1.3	2.4	1.4									
71 B 48	0.20	1400	0.71	68	0.80	1.4	5.6	2.1		56 48	0.0010	19	29	3 9	50	240	0.00132
	0.10	700	0.67	35	0.52	1.4	3.0	3.0									
80 A 48	0.30	1400	0.90	67	0.72	2.1	4.3	2.0		59 51	0.0022	26	36	6 17	60	240	0.00170
	0.15	710	1.05	42	0.48	2.0	2.7	1.7									
80 B 48	0.40	1400	0.95	71	0.86	2.7	4.2	1.8		59 51	0.0027	26	36	6 17	60	240	0.00210
	0.20	710	1.12	48	0.54	2.7	1.3	2.6									
90 S 48	0.60	1380	1.60	64	0.84	4.1	3.0	2.4		62 54	0.0034	33	52	12 35	140	240	0.00310
	0.30	700	1.70	47	0.54	4.1	2.1	2.1									
90 L 48	0.90	1370	2.00	74	0.90	6.4	4.0	1.8		62 54	0.0049	33	52	12 35	140	240	0.00370
	0.45	710	1.80	65	0.60	6.1	2.9	1.6									
100 LA 48	1.25	1400	3.20	81	0.70	8.5	3.8	2.0		63 55	0.0088	46	62	25 48	180	240	0.00562
	0.60	700	3.00	61	0.47	8.2	3.0	1.8									
100 LB 48	1.60	1445	3.60	73	0.88	10.6	4.8	1.9		63 55	0.0088	46	62	25 48	180	240	0.00662
	0.80	700	4.00	59	0.49	10.9	3.7	1.6									
112 M 48	2.55	1420	5.40	78	0.90	17.2	5.1	1.8		68 60	0.0172	65	100	34 70	250	240	0.01249
	1.25	710	4.90	66	0.61	16.8	4.1	2.5									
132 S 48	3.30	1430	7.20	77	0.86	22.5	5.0	1.7		72 64	0.0323	95	134	50 90	400	240	0.02908
	1.85	720	8.30	58	0.56	24.5	3.6	1.6									
132 MB 48	4.80	1410	10.50	77	0.86	32.5	5.3	1.8		75 67	0.0506	95	134	50 90	400	240	0.03648
	2.40	700	8.10	68	0.63	32.0	4.9	1.7									
132 L 48	5.50	1450	11.00	87	0.83	36.2	5.6	1.8		75 67	0.0506	105	134	50 90	400	240	0.04458
	3.00	720	13.50	72	0.45	40.0	4.6	1.8									
160 M 48	7.50	1450	16.00	82	0.82	49.4	5.8	1.9		77 69	0.0919	180	217	60 130	480	240	0.06771
	4.80	730	15.00	83	0.56	62.8	4.8	1.7									
160 L 48	10.00	1440	21.00	76	0.91	66.3	6.9	1.8		77 69	0.1218	195	217	60 130	480	240	0.08511
	6.60	710	22.00	73	0.59	88.8	2.8	1.8									
180 M 48	13.00	1474	26.50	81	0.87	84.1	6.6	2.0		79 70	0.2067	230	435	90 400	140	150	0.13560
	8.10	735	22.50	85	0.61	105.2	5.3	2.0									
180 L 48	16.00	1472	33.00	82	0.86	103.8	8.3	2.5		79 70	0.2067	245	435	90 400	140	150	0.16130
	9.90	735	27.00	88	0.60	128.6	6.2	2.5									
200 LB 48	20.00	1480	37.30	91	0.85	129.0	7.3	2.8		82 72	0.2436	315	495	300 400	140	150	0.25760
	13.00	730	39.00	86	0.56	170.2	4.6	2.9									
225 S 48	25.00	1460	47.50	82	0.93	163.5	6.5	2.1		84 73	0.3762	355	710	600 800	140	150	0.38570
	17.00	720	44.50	79	0.70	225.5	5.2	1.9									
225 M 48	30.00	1485	57.30	90	0.84	193.6	7.7	2.0		84 73	0.4451	380	750	600 800	140	150	0.45990
	20.00	735	61.00	88	0.54	261.0	4.5	1.5									
250 M 48	40.00	1480	73.00	91	0.88	258.4	6.4	2.2		86 75	0.4611	450	835	600 800	140	100	0.77930
	26.00	735	67.50	91	0.62	336.8	5.5	2.0									
280 S 48	59.00	1485	110.00	91	0.86	380.1	9.0	2.4		82 70	0.9500	875	○	○	○	○	○
	34.00	740	101.00	90	0.55	448.5	4.5	1.9									
280 M 48	71.00	1480	132.00	92	0.85	456.3	5.5	1.8		82 70	1.1200	901	○	○	○	○	○
	41.00	740	105.00	90	0.62	524.8	3.7	1.4									
315 S 48	80.00	1485	152.90	90	0.84	514.5	5.4	1.9		85 71	1.2700	971	○	○	○	○	○
	47.00	735	116.90	88	0.66	610.7	3.8	1.5									
315 M 48	85.00	1480	158.80	91	0.85	548.5	4.9	1.8		85 71	1.3300	984					
	50.00	735	123.00	89	0.66	649.7	3.8	1.4									
315 LA 48	○	○	○	○	○	○	○	○		○	○	○					
315 LB 48	○	○	○	○	○	○	○	○		○	○	○					
315 LC 48	○	○	○	○	○	○	○	○		○	○	○					

○ I dati non indicati sono forniti su richiesta
 Data not indicated is supplied on request
 Les données qui ne sont pas indiquées sont fournies sur demande
 Die nicht angegebenen Daten werden auf Anfrage geliefert
 Los datos que no se han precisado se pueden comunicar cuando se solicite

$$I_n^{\triangleright} = I_n \cdot \frac{400}{U}$$

(I_n = corrente a U' Volt);
 (I_n = current at U' Volt);
 (I_n = intensité à U' Volt);
 (I_n = Strom mit U' Volt);
 (I_n = corriente de U' Voltios);

$$J = \frac{PD^2}{4}$$

ITALIANO	Motori trifase	Velocità	giri/min	per uso generale - 2 avvolgimenti
ENGLISH	Three-phase motors	Speeds	rpm	for general purpose - 2 windings
FRANÇAIS	Moteurs triphasés	Vitesses	tours/min	pour usage général - 2 enroulements
DEUTSCH	4. Drehstrom Motoren	Drehzahlen	1500 U/min	für allgemeinen Gebrauch - 2 Wicklungen
ESPAÑOL	4.3 Motores trifásicos	2 Velocidades	1000 rev/min	para uso general - 2 devanados

Tipo motore	Potenza resa	Velocità	Corrente	Rendimento	Fattore potenza	Coppia	Corrente avviamento	Coppia avviamento	Rumorosità	Momento d'inerzia	Massa				
Motor type	Rated output	Speed	Current	Efficiency	Power factor	Torque	Starting current	Starting torque	Noise level	Moment of inertia	Mass				
Moteur type	Puissance mécanique	Vitesse	Intensité	Rendement	Facteur de puissance	Couple	Intensité démarrage	Couple démarrage	Niveau de bruit	Moment d'inertie	Masse				
Motor Typ	Leistung	Drehzahl	Strom	Wirkungsgrad	Leistungs-faktor	Moment	Anlaufstrom	Anlauf-moment	Schalldruck-pegel	Trägheits-moment	Masse				
Tipo de motor	Potencia proporcionada	Velocidad	Corriente	Rendimiento	Factor de potencia	Par	Corriente de arranque	Par de arranque	Nivel de ruido	Momento de inercia	Peso				
	P _n [KW]	n [1/min]	I _n ^P [A]	η [%]	cos φ	M _n [Nm]	I _a /I _n	M _a /M _n	[dB(A)] L _w L _p	J [▼] [kgm ²]	m [kg]				
71 B 46	0.20 0.10	1420 900	0.76 0.57	60 50	0.63 0.51	1.3 1.1	4.5 4.2	1.4 1.4	56 48	0.0010	19				
80 A 46	0.40 0.20	1360 900	1.00 0.86	80 56	0.72 0.60	2.8 2.1	3.5 2.9	1.5 1.4	59 51	0.0027	26				
80 B 46	0.50 0.30	1380 910	1.40 0.95	70 68	0.73 0.67	3.4 3.2	3.7 3.1	1.5 1.5	59 51	0.0027	26				
90 S 46	0.65 0.45	1400 910	2.00 1.70	63 55	0.75 0.70	4.4 4.7	2.0 1.9	1.6 1.4	62 54	0.0034	33				
90 L 46	0.95 0.60	1455 920	2.70 1.60	80 71	0.65 0.78	6.4 6.3	5.6 3.7	1.6 1.5	62 54	0.0049	33				
100 LA 46	1.40 0.90	1400 930	3.80 2.90	70 64	0.76 0.70	9.5 9.2	5.8 4.2	1.8 1.6	63 55	0.0088	46				
100 L 46	1.85 1.10	1415 900	4.20 3.05	77 71	0.84 0.73	12.7 11.5	4.5 3.0	1.8 1.6	63 55	0.0088	46				
112 M 46	2.40 1.60	1420 920	5.20 4.20	79 71	0.84 0.78	16.1 16.6	6.6 4.4	1.8 1.6	68 60	0.0172	65				
132 S 46	3.00 2.00	1475 960	8.30 5.50	83 75	0.65 0.71	20.0 19.7	6.0 4.0	2.0 1.5	72 64	0.0323	95				
132 MA 46	4.00 2.60	1460 960	9.40 8.40	79 72	0.78 0.62	26.2 25.9	6.2 4.6	2.0 1.8	75 67	0.0395	95				
132 MB 46	4.40 3.00	1450 950	10.50 8.90	76 79	0.80 0.62	29.0 30.2	6.4 4.5	2.0 1.8	75 67	0.0506	105				
132 L 46	5.15 3.30	1470 965	12.00 9.50	83 79	0.75 0.64	33.5 32.7	6.9 4.8	1.9 1.7	75 67	0.0506	105				
160 M 46	6.60 4.40	1460 960	14.50 10.50	79 87	0.84 0.70	43.2 43.8	6.8 4.6	2.0 1.9	77 69	0.0919	180				
160 L 46	8.80 5.90	1460 970	18.50 13.50	78 88	0.88 0.72	57.6 58.1	7.0 5.0	2.0 1.9	77 69	0.1218	195				
180 M 46	11.00 7.50	1470 980	21.50 18.50	88 84	0.84 0.70	71.5 73.1	6.6 5.2	2.0 1.9	79 70	0.2067	230				
180 L 46	13.00 8.80	1475 980	25.00 20.50	88 86	0.85 0.72	84.2 85.7	8.9 8.5	2.3 3.8	79 70	0.2067	245				
200 LA 46	16.00 11.00	1480 985	33.50 24.50	82 80	0.84 0.81	103.2 106.6	6.7 5.4	2.1 1.9	82 72	0.2986	295				
200 LB 46	18.50 13.00	1485 985	40.10 28.70	88 90	0.76 0.73	119.0 126.0	9.8 8.9	2.2 3.2	82 72	0.3503	315				
225 S 46	22.00 15.00	1485 995	42.50 33.50	89 88	0.84 0.74	141.8 144.4	8.1 5.5	2.6 3.6	84 73	0.6965	355				
225 M 46	26.00 16.50	1480 990	48.40 33.90	91 90	0.85 0.74	167.7 159.2	7.1 5.4	2.6 3.6	84 73	0.6965	380				
250 M 46	30.00 20.00	1480 990	55.90 41.30	90 90	0.87 0.78	195.2 193.5	5.0 4.9	1.2 1.4	86 75	0.7216	450				
280 S 46	56.00 34.00	1480 985	109.80 78.30	91 86	0.81 0.73	361.4 329.6	8.1 6.4	2.9 2.8	82 70	0.9500	875				
280 M 46	65.00 40.00	1480 985	124.50 89.60	92 86	0.82 0.75	419.4 387.8	8.2 6.2	2.8 2.9	82 70	1.1200	901				
315 S 46	75.00 46.00	1485 990	147.00 103.30	91 87	0.81 0.74	482.3 443.7	8.3 6.4	2.9 3.0	85 71	1.2700	971				
315 M 46	80.00 50.00	1488 990	145.00 104.40	96 93	0.84 0.74	518.0 482.6	6.9 5.0	2.0 2.2	85 71	1.3300	984				
315 LA 46	○	○	○	○	○	○	○	○	○ ○	○	○				
315 LB 46	○	○	○	○	○	○	○	○	○ ○	○	○				
315 LC 46	○	○	○	○	○	○	○	○	○ ○	○	○				

○ I dati non indicati sono forniti su richiesta
Data not indicated is supplied on request

Les données qui ne sont pas indiquées sont fournies sur demande

Die nicht angegebenen Daten werden auf Anfrage geliefert

Los datos que no se han precisado se pueden comunicar cuando se solicite

$$I'_n = I_n \cdot \frac{400}{U'} \quad (I'_n = \text{corrente a } U' \text{ Volt});$$

$$(I'_n = \text{current at } U' \text{ Volt});$$

$$(I'_n = \text{intensité à } U' \text{ Volt});$$

$$(I'_n = \text{Strom mit } U' \text{ Volt});$$

$$(I'_n = \text{corriente de } U' \text{ Voltios});$$

$$J = \frac{PD^2}{4}$$

ITALIANO	Motori trifase	Velocità	giri/min	per uso generale - 2 avvolgimenti
ENGLISH	Three-phase motors	Speeds	rpm	or general purpose - 2 windings
FRANÇAIS	Moteurs triphasés	Vitessees	tours/min	pour usage général - 2 enroulements
DEUTSCH	4. Drehstrom Motoren	Drehzahlen	1000 U/min	für allgemeinen Gebrauch - 2 Wicklungen
ESPAÑOL	4.3 Motores trifásicos	2 Velocidades	750 rev/min	para uso general - 2 devanados

Tipo motore	Potenza resa	Velocità	Corrente	Rendimento	Fattore potenza	Coppia	Corrente avviamento	Coppia avviamento	Rumorosità	Momento d'inerzia	Massa
Motor type	Rated output	Speed	Current	Efficiency	Power factor	Torque	Starting current	Starting torque	Noise level	Moment of inertia	Mass
Moteur type	Puissance mécanique	Vitesse	Intensité	Rendement	Facteur de puissance	Couple	Intensité démarrage	Couple démarrage	Niveau de bruit	Moment d'inertie	Masse
Motor Typ	Leistung	Drehzahl	Strom	Wirkungsgrad	Leistungs-faktor	Moment	Anlaufstrom	Anlauf-moment	Schalldruck-pegel	Trägheits-moment	Masse
Tipo de motor	Potencia proporcionada	Velocidad	Corriente	Rendimiento	Factor de potencia	Par	Corriente de arranque	Par de arranque	Nivel de ruido	Momento de inercia	Peso
	P _n [KW]	n [1/min]	I _n ^P [A]	η [%]	cos φ	M _n [Nm]	I _a /I _n	M _a /M _n	[dB(A)] Lw Lp	J [▼] [kgm ²]	m [kg]
71 B 68	0.12 0.08	960 670	0.73 0.48	45 32	0.55 0.77	1.2 1.2	3.0 1.4	2.4 1.0	50 42	0.0010	19
80 A 68	0.15 0.13	930 690	0.67 0.62	46 51	0.70 0.59	1.5 1.8	4.0 3.2	1.5 1.4	53 45	0.0027	26
80 B 68	0.25 0.15	920 680	1.00 0.81	51 46	0.71 0.58	2.6 2.1	2.8 2.6	1.6 1.3	53 45	0.0027	26
90 S 68	0.35 0.25	910 640	1.30 1.00	53 59	0.74 0.61	3.7 3.7	3.2 2.2	1.4 1.4	54 46	0.0034	33
90 L 68	0.60 0.30	920 690	2.12 1.55	53 41	0.72 0.58	6.2 4.1	3.2 2.6	1.5 1.7	54 46	0.0049	33
100 LA 68	0.80 0.55	920 700	2.30 1.90	66 67	0.76 0.62	8.3 7.5	1.7 1.8	1.5 1.5	63 55	0.0088	46
100 LB 68	1.00 0.65	920 680	3.30 2.55	54 50	0.82 0.74	10.4 9.1	3.0 2.6	1.1 1.4	63 55	0.0088	46
112 M 68	1.50 1.00	960 710	4.10 3.20	74 65	0.71 0.69	14.9 13.4	1.0 1.2	1.7 1.6	65 57	0.0172	65
132 S 68	1.85 1.30	960 715	5.20 4.20	73 68	0.70 0.66	18.4 17.4	4.1 4.0	1.6 1.7	68 60	0.0323	95
132 MA 68	2.55 1.85	965 720	6.80 5.80	75 68	0.72 0.68	25.2 24.5	4.2 4.1	1.8 1.8	68 60	0.0395	95
132 MB 68	3.00 2.00	970 730	7.40 6.00	79 73	0.74 0.66	29.5 26.2	5.4 3.9	1.9 1.8	68 60	0.0506	105
160 M 68	4.00 2.80	980 730	10.80 9.50	84 77	0.65 0.56	39.6 36.7	6.0 4.8	2.3 2.7	72 64	0.0919	180
160 L 68	5.50 4.00	985 732	14.60 11.60	86 81	0.64 0.63	53.5 52.9	7.7 5.6	2.5 2.3	72 64	0.1218	195
180 M 68	6.50 5.00	970 720	15.00 12.50	83 77	0.75 0.75	64.0 66.3	4.1 4.3	1.7 1.8	76 67	0.2067	230
180 L 68	8.00 6.00	965 715	17.50 15.00	85 78	0.78 0.74	79.2 80.1	4.4 4.2	1.8 1.9	76 67	0.2067	245
200 LA 68	9.90 7.50	970 710	21.00 18.00	85 80	0.80 0.75	97.5 100.9	4.6 4.3	1.7 1.7	79 69	0.2986	295
200 LB 68	12.00 8.80	990 736	33.40 22.20	88 87	0.59 0.66	115.8 114.3	7.0 4.9	2.4 1.7	79 69	0.3503	315
225 S 68	15.00 11.00	970 720	32.50 24.50	82 83	0.81 0.78	147.7 145.9	4.8 4.7	1.8 1.8	81 70	0.6965	355
225 M 68	17.00 13.00	975 725	37.00 30.50	81 80	0.82 0.77	166.5 171.2	4.9 4.6	1.8 1.9	81 70	0.6965	380
250 M 68	22.00 16.00	980 730	48.50 37.00	82 82	0.80 0.76	214.4 209.3	4.7 4.5	1.9 1.8	81 70	0.7216	450
280 S 68	37.00 25.00	990 740	80.30 57.00	90 88	0.74 0.72	356.9 322.6	7.3 5.3	3.1 2.7	77 65	1.1400	858
280 M 68	44.00 30.00	995 740	97.00 70.40	91 88	0.72 0.70	422.3 387.2	7.5 5.2	3.0 2.7	77 65	1.3600	894
315 S 68	52.00 36.00	990 745	112.80 81.20	90 89	0.74 0.72	501.6 461.5	7.9 5.4	3.4 2.9	79 65	1.6300	965
315 M 68	60.00 40.00	995 743	132.30 91.80	91 90	0.72 0.70	575.9 514.1	7.8 5.3	3.3 2.9	79 65	1.8300	997
315 LA 68	○	○	○	○	○	○	○	○	○ ○	○ ○	○ ○
315 LB 68	○	○	○	○	○	○	○	○	○ ○	○ ○	○ ○
315 LC 68	○	○	○	○	○	○	○	○	○ ○	○ ○	○ ○

○
I dati non indicati sono forniti su richiesta
Data not indicated is supplied on request
Les données qui ne sont pas indiquées sont fournies sur demande
Die nicht angegebenen Daten werden auf Anfrage geliefert
Los datos que no se han precisado se pueden comunicar cuando se solicite

$$I'_n = I_n \cdot \frac{400}{U'} \quad (I'_n = \text{corrente a } U' \text{ Volt});$$

$$(I'_n = \text{current at } U' \text{ Volt});$$

$$(I'_n = \text{intensité à } U' \text{ Volt});$$

$$(I'_n = \text{Strom mit } U' \text{ Volt});$$

$$(I'_n = \text{corriente de } U' \text{ Voltios});$$

$$J = \frac{PD^2}{4}$$

ITALIANO	Motori trifase	Velocità	giri/min	per macchine centrifughe - 1 avvolgimento Dahlander
ENGLISH	Three-phase motors	Speeds	rpm	for centrifugal machines - 1 winding Dahlander
FRANÇAIS	Moteurs triphasés	Vitesses	tours/min	pour machines centrifuge - 1 enroulement Dahlander
DEUTSCH	4. Drehstrom Motoren	Drehzahlen	3000 U/min	für Zentrifugalmaschinen - 1 Wicklung Dahlander
ESPAÑOL	4.4 Motores trifásicos	2 Velocidades	1500 rev/min	para máquinas centrifugas - 1 devanado Dahlander

Tipo motore	Potenza resa	Velocità	Corrente	Rendimento	Fattore potenza	Coppia	Corrente avviamento	Coppia avviamento	Rumorosità	Momento d'inerzia	Massa
Motor type	Rated output	Speed	Current	Efficiency	Power factor	Torque	Starting current	Starting torque	Noise level	Moment of inertia	Mass
Moteur type	Puissance mécanique	Vitesse	Intensité	Rendement	Facteur de puissance	Couple	Intensité démarrage	Couple démarrage	Niveau de bruit	Moment d'inertie	Masse
Motor Typ	Leistung	Drehzahl	Strom	Wirkungsgrad	Leistungsfaktor	Moment	Anlaufstrom	Anlaufmoment	Schalldruckpegel	Trägheitsmoment	Masse
Tipo de motor	Potencia proporcionada	Velocidad	Corriente	Rendimiento	Factor de potencia	Par	Corriente de arranque	Par de arranque	Nivel de ruido	Momento de inercia	Peso
	P _n [KW]	n [1/min]	I _n ^P [A]	η [%]	cos φ	M _n [Nm]	I _a /I _n	M _a /M _n	[dB(A)] L _w L _p	J [▼] [kgm ²]	m [kg]
63 B 24	0.24 0.07	2800 1340	0.86 0.34	55 43	0.75 0.71	0.8 0.5	4.1 2.1	3.0 1.9	60 52	0.0001	16
71 A 24	0.37 0.09	2750 1380	1.00 0.27	74 69	0.72 0.70	1.3 0.6	3.6 2.9	2.0 2.0	66 58	0.0004	19
71 B 24	0.50 0.14	2810 1380	1.50 0.42	67 72	0.72 0.70	1.7 1.0	2.5 4.5	1.8 2.0	66 58	0.0004	19
80 A 24	0.75 0.18	2820 1400	1.90 0.48	70 70	0.80 0.76	2.5 1.2	4.0 3.6	1.7 2.1	70 62	0.0006	26
80 B 24	0.11 0.25	2800 1380	2.60 0.71	75 66	0.82 0.76	3.8 1.7	4.2 3.7	1.8 2.0	70 62	0.0008	26
90 S 24	1.50 0.37	2780 1400	3.20 1.00	81 68	0.84 0.78	5.2 2.5	5.8 4.1	1.9 2.1	77 69	0.0012	33
90 L 24	2.00 0.51	2760 1380	4.30 1.30	77 68	0.88 0.82	7.0 3.5	4.3 3.2	1.9 2.1	77 69	0.0015	33
100 M 24	2.60 0.62	2810 1410	5.60 1.60	75 69	0.89 0.81	8.8 4.2	7.7 7.0	2.2 2.0	80 72	0.0029	46
100 L 24	3.30 0.75	2870 1480	7.70 2.20	78 57	0.80 0.85	11.0 4.8	5.6 5.1	2.2 2.0	80 72	0.0029	46
112 M 24	4.41 1.10	2930 1450	8.90 2.30	81 82	0.88 0.83	14.4 7.2	7.9 6.9	2.5 2.7	80 72	0.0074	65
132 S 24	6.50 2.00	2910 1450	12.50 4.80	83 75	0.90 0.80	21.3 13.2	6.2 6.0	2.1 1.9	83 75	0.0150	95
132 M 24	8.50 2.50	2945 1460	16.70 5.50	89 88	0.82 0.74	27.6 16.4	8.8 5.9	3.4 2.8	83 75	0.0178	95
132 L 24	9.20 2.80	2910 1440	17.50 5.70	90 87	0.84 0.82	30.2 18.6	6.9 6.6	2.3 2.2	83 75	0.0216	105
160 M 24	12.00 3.00	2955 1470	21.50 6.45	89 84	0.90 0.81	38.7 19.6	8.1 4.9	2.1 2.5	84 76	0.0360	180
160 L 24	16.00 4.40	2945 1455	29.60 8.90	87 87	0.90 0.82	51.6 29.0	7.0 5.3	2.5 2.6	84 76	0.0534	195
180 M 24	18.00 5.00	2965 1465	37.00 11.40	79 75	0.89 0.85	58.0 32.6	8.4 7.1	2.6 2.3	83 74	0.0750	230
180 L 24	24.00 6.00	2960 1480	44.50 11.80	90 89	0.87 0.83	77.4 39.0	9.7 9.6	3.3 3.1	83 74	0.0750	245
200 LB 24	30.00 8.00	2970 1480	51.20 15.60	92 88	0.92 0.86	96.5 52.2	7.2 7.2	2.0 1.9	87 77	0.1449	315
225 S 24	37.00 9.20	2960 1460	68.00 21.00	86 74	0.91 0.86	119.4 60.2	7.3 7.0	2.1 2.0	89 79	0.1714	355
225 M 24	44.00 11.50	2970 1480	78.00 21.80	91 91	0.90 0.84	141.5 74.3	9.0 8.4	2.6 2.4	89 79	0.2656	380
250 M 24	51.00 13.50	2970 1475	93.00 26.50	89 87	0.89 0.85	164.0 87.4	6.5 6.2	2.2 1.8	90 79	0.2809	450
280 S 24	70.00 25.00	2960 1480	130.80 49.40	91 85	0.85 0.86	225.8 161.3	9.4 8.2	2.8 2.7	88 76	0.5200	875
280 M 24	86.00 31.00	2960 1480	158.80 63.50	91 84	0.86 0.84	277.5 200.0	9.2 8.0	2.8 2.6	88 76	0.6300	901
315 S 24	100.00 36.00	2965 1485	181.50 75.50	91 83	0.87 0.83	322.1 231.5	9.4 8.0	2.9 2.9	90 76	0.7000	971
315 M 24	110.00 40.00	2970 1485	196.30 83.90	92 84	0.88 0.82	353.7 257.2	9.5 8.1	2.9 2.8	90 76	0.7500	948
315 LA 24	○	○	○	○	○	○	○	○	○ ○	○	○
315 LB 24	○	○	○	○	○	○	○	○	○ ○	○	○
315 LC 24	○	○	○	○	○	○	○	○	○ ○	○	○

○
I dati non indicati sono forniti su richiesta
Data not indicated is supplied on request
Les données qui ne sont pas indiquées sont fournies sur demande
Die nicht angegebenen Daten werden auf Anfrage geliefert
Los datos que no se han precisado se pueden comunicar cuando se solicite

$$I'_n = I_n \cdot \frac{400}{U'} \quad (I'_n = \text{corrente a } U' \text{ Volt});$$

$$(I'_n = \text{current at } U' \text{ Volt});$$

$$(I'_n = \text{intensité à } U' \text{ Volt});$$

$$(I'_n = \text{Strom mit } U' \text{ Volt });$$

$$(I'_n = \text{corriente de } U' \text{ Voltios});$$

$$J = \frac{PD^2}{4}$$

ITALIANO	Motori trifase	Velocità	giri/min	per macchine centrifughe - 2 avvolgimenti
ENGLISH	Three-phase motors	Speeds	rpm	for centrifugal machines - 2 windings
FRANÇAIS	Moteurs triphasés	Vitesses	tours/min	pour machines centrifuge - 2 enroulements
DEUTSCH	4. Drehstrom Motoren	Drehzahlen	U/min	für Zentrifugalmaschinen - 2 Wicklungen
ESPAÑOL	4.4 Motores trifásicos	2 Velocidades	1000 rev/min	para máquinas centrifugas - 2 devanados

Tipo motore	Potenza resa	Velocità	Corrente	Rendimento	Fattore potenza	Coppia	Corrente avviamento	Coppia avviamento	Rumorosità	Momento d'inerzia	Massa				
Motor type	Rated output	Speed	Current	Efficiency	Power factor	Torque	Starting current	Starting torque	Noise level	Moment of inertia	Mass				
Moteur type	Puissance mécanique	Vitesse	Intensité	Rendement	Facteur de puissance	Couple	Intensité démarrage	Couple démarrage	Niveau de bruit	Moment d'inertie	Masse				
Motor Typ	Leistung	Drehzahl	Strom	Wirkungsgrad	Leistungsfaktor	Moment	Anlaufstrom	Anlaufmoment	Schalldruckpegel	Trägheitsmoment	Masse				
Tipo de motor	Potencia proporcionada	Velocidad	Corriente	Rendimiento	Factor de potencia	Par	Corriente de arranque	Par de arranque	Nivel de ruido	Momento de inercia	Peso				
	P _n [KW]	n [1/min]	I _n ^p [A]	η [%]	cos φ	M _n [Nm]	I _a /I _n	M _a /M _n	[dB(A)] L _w L _p	J [▼] [kgm ²]	m [kg]				
71 B 46	0.30 0.10	1390 905	0.95 0.45	56 46	0.82 0.76	2.1 1.1	2.9 2.0	1.2 1.1	56 48	0.0009	19				
80 A 46	0.44 0.13	1430 930	1.40 0.49	65 55	0.70 0.70	2.9 1.3	3.0 7.8	1.6 1.2	59 51	0.0013	26				
80 B 46	0.59 0.18	1430 950	1.60 0.67	74 56	0.72 0.69	4.0 1.8	4.0 3.6	1.7 1.9	59 51	0.0013	26				
90 S 46	0.90 0.30	1440 970	2.95 2.20	68 41	0.66 0.49	5.9 2.9	4.1 2.4	2.5 2.7	62 54	0.0020	33				
90 L 46	1.15 0.40	1395 920	3.20 1.65	70 51	0.77 0.69	8.3 4.2	3.9 2.5	2.2 2.0	62 54	0.0026	33				
100 LA 46	1.80 0.60	1430 955	4.10 1.90	79 70	0.80 0.65	12.0 6.0	5.2 4.0	2.0 1.7	63 55	0.0053	46				
100 LB 46	2.20 0.70	1425 950	4.70 2.10	80 73	0.85 0.66	14.7 7.0	5.0 3.8	1.9 1.6	63 55	0.0053	46				
112 M 46	3.00 0.90	1455 960	6.90 2.30	76 75	0.83 0.75	19.7 9.0	5.0 4.3	1.9 1.8	68 60	0.0103	65				
132 S 46	4.00 1.20	1460 980	9.50 4.60	79 68	0.77 0.55	26.2 11.7	6.5 5.2	2.0 1.7	72 64	0.0250	95				
132 MA 46	4.80 1.40	1455 965	11.50 5.10	75 68	0.80 0.58	31.5 13.9	6.9 5.4	1.9 1.8	75 67	0.0324	95				
132 MB 46	5.50 1.70	1460 960	13.00 6.50	76 63	0.80 0.60	36.0 16.9	5.7 4.9	1.9 2.0	75 67	0.0324	105				
132 L 46	6.60 2.00	1470 980	15.50 8.00	88 76	0.70 0.49	42.9 20.0	6.9 5.4	1.8 1.8	75 67	0.0405	105				
160 M 46	7.50 2.50	1470 985	15.35 6.67	86 83	0.82 0.66	48.9 24.4	7.1 6.2	2.1 2.2	77 69	0.0627	180				
160 L 46	11.00 3.30	1460 980	23.00 9.50	82 71	0.84 0.71	71.9 32.2	7.1 6.2	2.2 2.3	77 69	0.0801	195				
180 M 46	15.00 5.20	1450 960	31.50 21.00	81 85	0.85 0.57	98.8 51.7	6.9 6.0	1.8 1.6	79 70	0.1270	230				
180 L 46	18.50 6.25	1450 965	36.00 22.00	84 66	0.88 0.62	121.8 61.8	7.0 6.2	7.0 6.2	79 70	0.1488	245				
200 LA 46	21.00 7.50	1460 970	41.00 16.50	85 82	0.87 0.80	137.4 73.8	6.9 6.5	2.0 1.9	82 72	0.2436	295				
200 LB 46	26.00 8.80	1465 970	48.50 24.50	89 83	0.87 0.63	169.5 86.6	6.4 6.8	1.8 2.1	82 72	0.2436	315				
225 S 46	31.00 11.00	1470 975	58.00 23.00	88 82	0.88 0.84	201.4 107.7	6.5 6.0	2.2 2.1	84 73	0.3762	355				
225 M 46	36.00 12.00	1475 990	70.00 30.00	88 86	0.84 0.68	233.0 117.0	4.9 6.1	2.2 2.0	84 73	0.4451	380				
250 M 46	38.00 14.00	1485 985	72.66 28.89	89 85	0.85 0.83	244.5 136.0	5.6 5.4	1.9 1.9	86 75	0.4611	450				
280 S 46	65.00 25.00	1480 980	123.00 63.60	92 86	0.83 0.66	419.4 243.6	8.1 6.4	2.9 2.8	82 70	0.9500	875				
280 M 46	80.00 30.00	1485 995	145.20 76.30	96 91	0.84 0.63	518.0 291.6	8.2 6.2	2.8 2.9	82 70	1.1200	901				
315 S 46	90.00 35.00	1485 985	170.30 89.40	92 87	0.83 0.65	578.8 339.3	8.3 6.4	2.9 3.0	85 71	1.2700	971				
315 M 46	95.00 37.00	1485 990	179.80 92.10	92 88	0.83 0.66	610.9 356.9	8.2 6.4	2.8 3.0	85 71	1.3300	984				
315 LA 46	○	○	○	○	○	○	○	○	○ ○	○ ○	○ ○				
315 LB 46	○	○	○	○	○	○	○	○	○ ○	○ ○	○ ○				
315 LC 46	○	○	○	○	○	○	○	○	○ ○	○ ○	○ ○				

○
I dati non indicati sono forniti su richiesta
Data not indicated is supplied on request
Les données qui ne sont pas indiquées sont fournies sur demande
Die nicht angegebenen Daten werden auf Anfrage geliefert
Los datos que no se han precisado se pueden comunicar cuando se solicite

$$I'_n = I_n \cdot \frac{400}{U'} \quad (I'_n = \text{corrente a } U' \text{ Volt});$$

$$(I'_n = \text{current at } U' \text{ Volt});$$

$$(I'_n = \text{intensité à } U' \text{ Volt});$$

$$(I'_n = \text{Strom mit } U' \text{ Volt});$$

$$(I'_n = \text{corriente de } U' \text{ Voltios});$$

$$J = \frac{PD^2}{4}$$

ITALIANO	4.	Motori trifase	Velocità	1000	giri/min	per macchine centrifughe - 2 avvolgimenti
ENGLISH	4.4	Three-phase motors	Speeds	750	rpm	for centrifugal machines - 2 windings
FRANÇAIS		Moteurs triphasés	Vitesses		tours/min	pour machines centrifuge - 2 enroulements
DEUTSCH		Drehstrom Motoren	Drehzahlen		U/min	für Zentrifugalmaschinen - 2 Wicklungen
ESPAÑOL		Motores trifásicos	Velocidades		rev/min	para máquinas centrifugas - 2 devanados

Tipo motore	Potenza resa	Velocità	Corrente	Rendimento	Fattore potenza	Coppia	Corrente avviamento	Coppia avviamento	Rumorosità	Momento d'inerzia	Massa
Motor type	Rated output	Speed	Current	Efficiency	Power factor	Torque	Starting current	Starting torque	Noise level	Moment of inertia	Mass
Moteur type	Puissance mécanique	Vitesse	Intensité	Rendement	Facteur de puissance	Couple	Intensité démarrage	Couple démarrage	Niveau de bruit	Moment d'inertie	Masse
Motor Typ	Leistung	Drehzahl	Strom	Wirkungsgrad	Leistungs-faktor	Moment	Anlaufstrom	Anlauf-moment	Schalldruck-pegel	Trägheits-moment	Masse
Tipo de motor	Potencia proporcionada	Velocidad	Corriente	Rendimiento	Factor de potencia	Par	Corriente de arranque	Par de arranque	Nivel de ruido	Momento de inercia	Peso
	P _n [KW]	n [1/min]	I _n ^P [A]	η [%]	cos φ	M _n [Nm]	I _a /I _n	M _a /M _n	[dB(A)] Lw Lp	J [▼] [kgm ²]	m [kg]
80 A 68	0.33 0.09	930 700	1.15 0.64	59 33	0.68 0.51	3.4 1.2	3.2 2.0	1.8 1.4	53 45	0.0027	26
80 B 68	0.40 0.12	930 680	1.20 0.65	61 44	0.76 0.63	4.1 1.7	2.9 2.0	1.7 1.8	53 45	0.0027	26
90 S 68	0.48 0.19	895 705	1.54 0.82	52 52	0.89 0.65	5.3 2.6	2.2 2.7	1.6 3.3	54 46	0.0034	33
90 L 68	0.66 0.25	925 700	2.10 1.25	63 46	0.72 0.65	6.9 3.4	2.6 2.0	2.0 3.0	54 46	0.0049	33
100 LA 68	0.88 0.37	960 715	2.90 1.80	66 47	0.66 0.63	8.8 4.9	4.1 3.6	1.8 1.7	63 55	0.0088	46
100 L 68	1.10 0.44	930 720	3.25 2.20	68 55	0.75 0.55	11.6 5.9	3.2 2.9	2.2 2.9	63 55	0.0088	46
112 M 68	1.50 0.75	970 725	4.60 3.30	74 60	0.64 0.54	14.8 9.9	4.2 3.4	2.0 2.6	65 57	0.0172	65
132 S 68	2.20 0.88	975 730	6.00 3.50	79 67	0.67 0.54	21.6 11.6	4.5 3.8	2.2 1.7	68 60	0.0323	95
132 MA 68	3.00 1.20	960 730	7.00 4.80	76 59	0.81 0.61	29.8 15.7	4.9 3.9	2.0 2.0	68 60	0.0395	95
132 MB 68	3.70 1.50	965 715	8.90 5.00	79 64	0.76 0.68	36.6 20.0	5.1 3.9	2.2 2.1	68 60	0.0506	105
160 M 68	5.50 2.50	980 730	12.50 6.80	87 83	0.73 0.64	53.6 32.7	5.6 4.3	2.2 2.3	72 64	0.0919	180
160 L 68	7.50 4.00	970 728	17.40 11.60	83 78	0.75 0.64	73.9 52.8	5.8 4.0	1.8 2.3	72 64	0.1218	195
180 M 68	9.00 4.50	965 725	20.00 11.00	83 80	0.78 0.74	89.1 59.3	5.8 4.3	2.3 2.2	76 67	0.2067	230
180 L 68	10.00 5.20	960 720	23.50 13.00	79 80	0.78 0.72	99.5 69.0	5.6 4.1	2.1 2.0	76 67	0.2067	245
200 LA 68	13.00 6.50	970 720	29.50 15.50	81 82	0.79 0.74	128.0 86.2	5.3 4.7	2.0 2.1	79 69	0.2986	295
200 LB 68	16.00 8.10	970 725	36.00 21.00	80 72	0.80 0.77	157.5 106.7	5.2 4.6	1.9 2.0	79 69	0.3503	315
225 S 68	20.00 10.00	980 730	41.00 24.50	88 76	0.80 0.78	194.9 130.8	5.0 4.9	2.3 2.2	81 70	0.6965	355
225 M 68	23.00 11.00	988 737	46.40 25.20	91 89	0.79 0.72	223.9 144.8	5.0 4.2	1.9 1.7	81 70	0.6965	380
250 M 68	26.00 13.00	980 730	53.00 31.50	89 75	0.80 0.80	253.3 170.1	4.8 4.5	1.8 1.7	81 70	0.7216	450
280 S 68	40.00 16.00	985 740	81.40 38.20	91 84	0.78 0.72	387.8 206.5	7.3 5.3	3.1 2.7	77 65	1.1400	875
280 M 68	48.00 20.00	990 740	99.50 53.40	90 86	0.68 0.63	464.5 258.0	7.5 5.2	3.0 2.7	77 65	1.3600	901
315 S 68	58.00 24.00	990 742	119.60 56.90	91 87	0.77 0.70	559.5 308.9	7.9 5.4	3.4 2.9	79 65	1.6300	971
315 M 68	65.00 27.00	995 740	130.90 62.30	92 87	0.78 0.72	623.9 348.4	7.8 5.3	3.3 2.9	79 65	1.8300	884
315 LA 68	○	○	○	○	○	○	○	○	○ ○	○ ○	○ ○
315 LB 68	○	○	○	○	○	○	○	○	○ ○	○ ○	○ ○
315 LC 68	○	○	○	○	○	○	○	○	○ ○	○ ○	○ ○

○
I dati non indicati sono forniti su richiesta
Data not indicated is supplied on request
Les données qui ne sont pas indiquées sont fournies sur demande
Die nicht angegebenen Daten werden auf Anfrage geliefert
Los datos que no se han precisado se pueden comunicar cuando se solicite

$$I'_n = I_n \cdot \frac{400}{U'} \quad (I'_n = \text{corrente a } U' \text{ Volt});$$

$$(I'_n = \text{current at } U' \text{ Volt});$$

$$(I'_n = \text{intensité à } U' \text{ Volt});$$

$$(I'_n = \text{Strom mit } U' \text{ Volt});$$

$$(I'_n = \text{corriente de } U' \text{ Voltios});$$

$$J = \frac{PD^2}{4}$$

ITALIANO	Motori monofase	Velocità	giri/min
ENGLISH	Single-phase motors	Speed	rpm
FRANÇAIS	Moteurs monophasé	Vitesse	tours/min
DEUTSCH	Einphasen Motoren	Drehzahl	U/min
ESPAÑOL	Motores monofásicos	Velocidad	rev/min

4.
4.5

1

3000
1500
1000

Tipo motore	Potenza resa	Velocità	Corrente	Rendimento	Fattore potenza	Coppia	Corrente avviamento	Coppia avviamento	Condensatore	Rumorosità	Momento d'inerzia	Massa
Motor type	Rated output	Speed	Current	Efficiency	Power factor	Torque	Starting current	Starting torque	Capacitor	Noise level	Moment of inertia	Mass
Moteur type	Puissance mécanique	Vitesse	Intensité	Rendement	Facteur de puissance	Couple	Intensité démarrage	Couple démarrage	Condensateur	Niveau de bruit	Moment d'inertie	Masse
Motor Typ	Leistung	Drehzahl	Strom	Wirkungsgrad	Leistungs-faktor	Moment	Anlaufstrom	Anlauf-moment	Kondensator	Schalldruck-pegel	Trägheits-moment	Masse
Tipo de motor	Potencia proporcionada	Velocidad	Corriente	Rendimiento	Factor de potencia	Par	Corriente de arranque	Par de arranque	Condensador	Nivel de ruido	Momento de inercia	Peso
	P _n [KW]	n [1/min]	I _n ^P [A]	η [%]	cos φ	M _n [Nm]	I _a /I _n	M _a /M _n	C [μF]	[dB(A)] L _w L _p	J [▼] [kgm ²]	m [kg]
63 A 2	0.10	2750	1.30	35	0.95	0.3	3.3	0.6	6.3	60 52	0.0001	16
63 B 2	0.15	2750	1.30	53	0.95	0.5	3.8	0.6	8.0	60 52	0.0001	16
71 A 2	0.20	2800	2.60	48	0.92	0.7	3.6	0.7	10.0	66 58	0.0004	19
71 B 2	0.40	2730	2.90	63	0.95	1.4	2.7	0.7	12.5	66 58	0.0004	19
80 A 2	0.55	2720	5.40	53	0.82	1.9	2.5	0.6	16.0	70 62	0.0006	26
80 B 2	0.75	2790	5.30	63	0.97	2.6	4.5	0.8	20.0	70 62	0.0008	26
90 S 2	1.10	2750	7.80	63	0.97	3.8	4.4	0.7	45.0	77 69	0.0012	33
90 L 2	1.50	2800	8.90	74	0.98	5.1	4.9	0.7	60.0	77 69	0.0015	33
100 LA 2	2.20	2800	15.50	65	0.95	7.5	5.0	0.6	60.0	80 72	0.0029	46
100 LB 2	3.00	2800	18.00	74	0.98	10.2	5.0	0.6	80.0	80 72	0.0036	46
63 A 4	0.09	1360	1.10	39	0.90	0.6	3.2	0.6	6.3	52 44	0.0002	16
63 B 4	0.13	1350	1.30	55	0.90	1.1	3.0	0.6	8.0	52 44	0.0002	16
71 A 4	0.15	1380	1.70	42	0.90	1.0	3.2	0.7	10.0	56 48	0.0006	19
71 B 4	0.25	1380	2.30	48	0.97	1.7	3.4	0.7	12.5	56 48	0.0009	19
80 A 4	0.35	1410	3.30	49	0.96	2.4	3.8	0.7	20.0	59 51	0.0009	26
80 B 4	0.45	1420	4.30	53	0.85	3.0	3.8	0.8	25.0	59 51	0.0013	26
80 L 4	0.55	1420	4.90	56	0.87	3.7	3.9	0.7	20.0	59 51	0.0014	26
90 S 4	0.75	1420	5.90	56	0.97	5.2	2.1	1.0	30.0	62 54	0.0020	33
90 L 4	1.10	1430	7.20	73	0.91	7.3	4.0	0.6	35.0	62 54	0.0026	33
100 LA 4	1.30	1370	8.10	72	0.98	9.0	3.2	0.5	35.0	63 55	0.0043	46
100 LB 4	1.60	1400	10.00	71	0.98	11.1	2.6	0.5	40.0	63 55	0.0053	46
71 A 6	0.10	900	1.50	36	0.80	1.1	2.6	0.5	8.0	50 42	0.0007	19
71 B 6	0.15	850	1.40	50	0.93	1.7	2.8	0.5	10.0	50 42	0.0010	19
80 A 6	0.20	910	2.70	40	0.81	2.1	2.9	0.6	16.0	53 45	0.0022	26
80 B 6	0.30	930	3.00	53	0.82	3.1	3.0	0.6	25.0	53 45	0.0027	26
90 S 6	0.55	920	4.30	63	0.88	5.7	3.0	0.6	30.0	54 46	0.0034	33
90 L 6	0.75	910	6.10	60	0.88	7.9	3.1	0.7	35.0	54 46	0.0049	33
100 LB 6	1.10	920	8.00	65	0.92	11.4	3.2	0.7	75.0	63 55	0.0088	46

$$I'_n = I_n \cdot \frac{400}{U'} \quad (I'_n = \text{corrente a } U' \text{ Volt});$$

$$(I'_n = \text{current at } U' \text{ Volt});$$

$$(I'_n = \text{intensité à } U' \text{ Volt});$$

$$(I'_n = \text{Strom mit } U' \text{ Volt });$$

$$(I'_n = \text{corriente de } U' \text{ Voltios});$$

$$J = \frac{PD^2}{4}$$

ITALIANO	Motori trifase con freno	Velocità	giri/min	Servizio tipo	per sollevamento	Freno
ENGLISH	Three-phase motors with brake	Speed	rpm	Duty type	or hoist applications	Brake
FRANÇAIS	Moteurs triphasés avec frein	Vitesse	tours/min	Service type	pour levage	Frein
DEUTSCH	4. Drehstrom Motoren mit Bremse	Drehzahl	U/min	Betrieb	Hubmotoren	Bremse
ESPAÑOL	4.6 Motores trifásicos con freno	1 Velocidad	1000 rev/min	Régimen	40%	Freno

Tipo motore	Potenza resa	Velocità	Corrente	Rendimento	Fattore potenza	Coppia	Corrente avviamento	Coppia avviamento	Coppia massima	Rumorosità	Momento d'inerzia	Massa	Coppia	Potenza	Frenate per ora	Inerzia totale	
Motor type	Rated output	Speed	Current	Efficiency	Power factor	Torque	Starting current	Starting torque	Maximum torque	Noise level	Moment of inertia	Mass	Torque	Power	Braking: n° per hour	Total inertia	
Moteur type	Puissance mécanique	Vitesse	Intensité	Rendement	Facteur de puissance	Couple	Intensité démarrage	Couple démarrage	Couple maximal	Niveau de bruit	Moment d'inertie	Masse	Couple	Puissance	Freinages par heure	Inertie totale	
Motor Typ	Leistung	Drehzahl	Strom	Wirkungsgrad	Leistungs-faktor	Moment	Anlaufstrom	Anlauf-moment	Kippmoment	Schalldruck-pegel	Trägheits-moment	Masse	Moment	Leistung	Bremsungen pro Stunde	Gesamt Trägheit	
Tipo de motor	Potencia proporcionada	Velocidad	Corriente	Rendimiento	Factor de potencia	Par	Corriente de arranque	Par de arranque	Par máximo	Nivel de ruido	Momento de inercia	Peso	Par	Potencia	Frenados por hora	Inercia total	
	P _n [KW]	n [1/min]	I _n [▷] [A]	η [%]	cos φ	M _n [Nm]	I _a /I _n	M _a /M _n	M _m /M _n	[dB(A)] L _p	J [▼] [kgm ²]	m [kg]	[Nm] S1 S4	[VA/W]	[max n.] ●	[kgm ²]	
71 A 6	0.18	945	0.92	55.0	0.51	1.82	3.7	3.7	3.7	42	0.00112	29	3	9	50	240	0.00112
71 B 6	0.26	918	1.00	60.0	0.63	2.71	3.4	2.6	2.6	42	0.00142	29	3	9	50	240	0.00142
80 A 6	0.37	930	1.60	58.0	0.58	3.80	3.1	2.9	3.2	45	0.00300	36	6	17	60	240	0.00300
80 B 6	0.55	930	1.80	70.0	0.65	5.79	2.8	2.0	2.1	45	0.00350	36	6	17	60	240	0.00350
90 S 6	0.75	950	2.39	73.0	0.62	7.52	4.0	3.0	3.3	46	0.00450	52	12	35	140	240	0.00450
90 L 6	1.10	935	3.35	73.0	0.65	11.21	3.4	2.0	2.2	46	0.00600	52	12	35	140	240	0.00600
100 LB 6	1.50	950	3.80	76.0	0.75	15.11	4.2	2.0	2.3	55	0.01012	62	25	48	180	240	0.01012
112 M 6	2.20	960	6.11	80.0	0.65	21.84	5.2	2.3	2.1	57	0.01939	100	34	70	250	240	0.01939
132 SB 6	3.00	975	9.34	82.0	0.56	29.40	6.4	3.3	3.5	60	0.04046	134	50	90	400	240	0.03638
132 MB 6	4.00	970	9.84	86.0	0.69	39.38	6.0	2.0	2.5	60	0.04766	134	50	90	400	240	0.04358
132 ML 6	5.50	960	15.56	74.0	0.69	54.90	5.5	2.7	3.0	60	0.05876	134	50	90	400	240	0.05468
160 MB 6	7.50	950	15.70	85.0	0.81	75.33	4.8	2.1	2.1	64	0.09691	217	60	130	480	240	0.09661
160 L 6	11.00	965	25.60	89.0	0.70	109.20	5.0	2.5	2.9	64	0.12681	217	60	130	480	240	0.12681
180 L 6	15.00	984	33.41	93.0	0.70	145.70	7.7	3.0	3.5	67	0.23830	435	90	400	140	150	0.23830
200 LA 6	18.50	980	41.70	90.2	0.71	180.28	7.2	2.5	3.7	69	0.31060	490	300	400	140	150	0.31060
200 LB 6	22.00	985	49.90	90.4	0.70	212.97	7.3	2.8	4.4	69	0.03184	515	300	400	140	150	0.31840
225 M 6	30.00	985	61.00	91.7	0.78	290.86	5.8	2.0	2.5	70	0.77370	750	600	800	140	150	0.77370
250 M 6	37.00	990	72.00	94.0	0.70	358.00	5.2	2.0	2.4	70	1.05950	815	600	800	140	150	1.05950
250 ML 6	45.00	988	93.60	93.0	0.75	434.60	8.6	3.0	1.9	70	1.23000	905	600	800	140	150	1.24200
280 S 6	45.00	982	90.50	89.0	0.80	436.29	4.9	2.5	2.8	65	1.14000	1153	600	800	140	150	1.15200
280 M 6	55.00	980	109.00	91.0	0.81	535.00	4.7	2.3	2.4	65	1.36000	1189	600	800	140	150	1.37200
315 S 6	75.00	990	151.80	93.2	0.77	722.51	6.1	2.2	2.4	65	1.63000	1160	600	800	140	150	1.84200

● Numero di avviamenti superiori su richiesta
Higher number of start-ups by request
 Nombre de démarrages supérieurs sur demande
 Höhere Anzahl von Starts pro Stunde auf Anfrage
 Número de arranques superiores a petición

$$I'_n = I_n \cdot \frac{400}{U}$$

(I' _n = corrente a U' Volt);
 (I' _n = current at U' Volt);
 (I' _n = intensité à U' Volt);
 (I' _n = Strom mit U' Volt);
 (I' _n = corriente de U' Voltios);

$$J = \frac{PD^2}{4}$$

ITALIANO	Motori trifase con freno	Velocità	giri/min	Servizio tipo	per sollevamento	Freno
ENGLISH	Three-phase motors with brake	Speeds	rpm	Duty type	or hoist applications	Brake
FRANÇAIS	Moteurs triphasés avec frein	Vitesses	tours/min	Service type	pour levage	Frein
DEUTSCH	4. Drehstrom Motoren mit Bremse	Drehzahlen	3000 U/min	Betrieb	S4	Bremse
ESPAÑOL	4.6 Motores trifásicos con freno	2 Velocidades	750 rev/min	Régimen	40%	Freno

Tipo motore	Potenza resa	Velocità	Corrente	Rendimento	Fattore potenza	Coppia	Corrente avviamento	Coppia avviamento	Rumorosità	Momento d'inerzia	Massa	Coppia	Potenza	Frenate per ora	Inerzia totale
Motor type	Rated output	Speed	Current	Efficiency	Power factor	Torque	Starting current	Starting torque	Noise level	Moment of inertia	Mass	Torque	Power	Braking: n° per hour	Total inertia
Moteur type	Puissance mécanique	Vitesse	Intensité	Rendement	Facteur de puissance	Couple	Intensité démarrage	Couple démarrage	Niveau de bruit	Moment d'inertie	Masse	Couple	Puissance	Freinages par heure	Inertie totale
Motor Typ	Leistung	Drehzahl	Strom	Wirkungsgrad	Leistungs-faktor	Moment	Anlaufstrom	Anlauf-moment	Schalldruck-pegel	Trägheits-moment	Masse	Moment	Leistung	Bremsungen pro Stunde	Gesamt Trägheit
Tipo de motor	Potencia proporcionada	Velocidad	Corriente	Rendimiento	Factor de potencia	Par	Corriente de arranque	Par de arranque	Nivel de ruido	Momento de inercia	Peso	Par	Potencia	Frenados por hora	Inercia total

	P _n [KW]	n [1/min]	I _n ^P [A]	η [%]	cos φ	M _n [Nm]	I _a /I _n	M _a /M _n	[dB(A)] L _p	J [▼] [kgm ²]	m [kg]	[Nm] S1 S4	[VA/W]	[max n.] ●	[kgm ²]
71 B 28	0.36 0.06	2860 670	1.10 0.60	60.6 21.0	0.82 0.68	1.20 0.86	3.5 1.5	2.0 1.4	58	0.0009	29	6 9	50	240	0.00082
80 A 28	0.55 0.12	2935 688	1.32 0.85	77.0 45.0	0.78 0.45	1.79 1.77	6.4 1.6	2.4 1.3	62	0.0009	36	12 17	60	240	0.00140
80 B 28	0.66 0.17	2840 660	1.48 1.02	78.0 47.0	0.82 0.51	2.22 2.46	6.1 1.5	2.1 1.2	62	0.0013	36	12 17	60	240	0.00160
90 S 28	0.90 0.22	2845 680	2.45 1.35	58.0 36.0	0.91 0.65	3.02 3.09	4.8 2.1	2.9 2.8	69	0.0020	52	25 35	140	240	0.00230
90 L 28	1.10 0.30	2968 722	4.10 1.40	60.3 57.6	0.64 0.54	3.54 3.97	6.2 2.2	3.2 2.1	69	0.0026	52	25 35	140	240	0.00260
100 LA 28	1.30 0.33	2960 735	3.40 2.58	71.1 48.0	0.78 0.39	4.19 4.29	8.6 2.9	3.7 3.6	72	0.0043	62	34 48	180	240	0.00422
100 L 28	1.50 0.37	2930 725	4.00 3.00	70.0 47.0	0.78 0.38	4.89 4.87	6.1 2.4	2.5 3.7	72	0.0053	62	34 48	180	240	0.00662
112 M 28	2.60 0.70	2950 720	5.50 2.70	86.0 69.0	0.81 0.55	8.42 9.28	8.3 3.1	2.6 2.5	72	0.0103	100	50 70	250	240	0.00959
132 S 28	4.00 1.00	2950 720	6.80 4.20	83.0 63.0	0.91 0.60	12.95 13.26	8.5 3.3	2.7 2.3	75	0.03316	134	60 90	400	236	0.01648
132 M 28	5.00 1.25	2960 720	10.77 4.73	77.0 72.0	0.87 0.53	16.13 16.58	8.1 3.1	2.8 1.6	75	0.04056	134	60 90	400	236	0.02188
132 L 28	6.00 1.50	2950 710	14.42 7.34	78.0 59.0	0.77 0.50	19.42 20.18	7.2 2.4	3.0 1.7	75	0.04866	134	60 90	400	236	0.02568

● Numero di avviamenti superiori su richiesta
Higher number of start-ups by request
Nombre de démarrages supérieurs sur demande
Höhere Anzahl von Starts pro Stunde auf Anfrage
Número de arranques superiores a petición

▼ $I'_n = I_n \cdot \frac{400}{U}$ (I'_n = corrente a U' Volt);
(I'_n = current at U' Volt);
(I'_n = intensité à U' Volt);
(I'_n = Strom mit U' Volt);
(I'_n = corriente de U' Voltios);

$$J = \frac{PD^2}{4}$$

ITALIANO	Motori trifase con freno	Velocità	giri/min	Servizio tipo	per sollevamento	Freno
ENGLISH	Three-phase motors with brake	Speeds	rpm	Duty type	or hoist applications	Brake
FRANÇAIS	Moteurs triphasés avec frein	Vitesses	tours/min	Service type	pour levage	Frein
DEUTSCH	4. Drehstrom Motoren mit Bremse	Drehzahlen	1500 U/min	Betrieb	S4	Bremse
ESPAÑOL	4.6 Motores trifásicos con freno	2 Velocidades	500 rev/min	Régimen	40%	Freno

Tipo motore	Potenza resa	Velocità	Corrente	Rendimento	Fattore potenza	Coppia	Corrente avviamento	Coppia avviamento	Rumorosità	Momento d'inerzia	Massa	Coppia	Potenza	Frenate per ora	Inerzia totale	
Motor type	Rated output	Speed	Current	Efficiency	Power factor	Torque	Starting current	Starting torque	Noise level	Moment of inertia	Mass	Torque	Power	Braking: n° per hour	Total inertia	
Moteur type	Puissance mécanique	Vitesse	Intensité	Rendement	Facteur de puissance	Couple	Intensité démarrage	Couple démarrage	Niveau de bruit	Moment d'inertie	Masse	Couple	Puissance	Freinages par heure	Inertie totale	
Motor Typ	Leistung	Drehzahl	Strom	Wirkungsgrad	Leistungs-faktor	Moment	Anlaufstrom	Anlauf-moment	Schalldruck-pegel	Trägheits-moment	Masse	Moment	Leistung	Bremsungen pro Stunde	Gesamt Trägheit	
Tipo de motor	Potencia proporcionada	Velocidad	Corriente	Rendimiento	Factor de potencia	Par	Corriente de arranque	Par de arranque	Nivel de ruido	Momento de inercia	Peso	Par	Potencia	Frenados por hora	Inercia total	
	P _n [KW]	n [1/min]	I _n ^P [A]	η [%]	cos φ	M _n [Nm]	I _a /I _n	M _a /M _n	[dB(A)] L _p	J [▼] [kgm ²]	m [kg]	[Nm] S1 S4	[VA/W]	[max n.] ●	[kgm ²]	
90 S 41	0.55	1450	1.50	69.6	0.76	3.62	4.0	1.6	○	○	52	25	35	140	240	0.00310
	0.18	432	1.10	34.7	0.70	3.98	2.0	1.6								
90 L 41	0.75	1455	2.25	69.0	0.70	4.92	4.5	2.0	○	○	52	25	35	140	240	0.00370
	0.25	440	1.35	45.0	0.60	5.43	2.0	1.8								
100 LA 41	1.10	1473	4.80	56.3	0.59	7.13	4.8	3.4	○	○	62	34	48	180	240	0.00562
	0.37	478	3.65	31.3	0.47	7.39	1.6	2.5								
100 LB 41	1.50	1455	4.83	64.0	0.70	9.85	4.6	2.3	○	○	62	34	48	180	240	0.00662
	0.50	455	3.00	40.9	0.59	10.49	1.8	1.8								
112 M 41	1.80	1475	7.05	61.3	0.60	11.65	6.3	2.9	○	○	100	50	70	250	240	0.01249
	0.60	470	3.85	44.0	0.51	12.19	2.2	1.7								
132 S 41	2.20	1484	7.25	77.0	0.57	14.16	6.5	3.7	○	○	134	60	90	400	240	0.02908
	0.73	470	4.60	50.0	0.46	14.83	1.7	1.8								
132 M 41	3.50	1480	10.20	84.0	0.59	22.58	9.4	2.9	○	○	134	60	90	400	240	0.03648
	1.17	485	10.56	41.0	0.39	23.04	1.3	2.4								
132 L 41	4.00	1484	10.60	84.0	0.65	25.74	6.8	2.8	○	○	134	60	90	400	240	0.04458
	1.33	479	9.87	54.0	0.36	26.52	1.9	2.5								
160 M 41	5.50	1470	12.60	77.0	0.82	35.73	5.8	2.1	○	○	217	90	130	480	240	0.06771
	1.83	485	10.91	55.0	0.44	36.03	2.3	2.1								
160 L 41	7.50	1480	16.98	85.0	0.75	48.40	5.7	2.5	○	○	217	90	130	480	240	0.08511
	2.50	483	14.34	68.0	0.37	49.43	2.0	2.1								
180 M 41	9.00	1485	20.98	86.0	0.72	57.9	8.1	3.7	70	0.2383	435	300	400	140	150	0.13560
	3.00	485	17.62	63.0	0.39	59.1	2.0	2.1								
180 L 41	11.60	1480	24.80	92.5	0.73	74.8	8.3	3.5	70	0.2383	435	300	400	140	150	0.16130
	3.87	480	23.98	61.3	0.38	77.0	1.9	2.5								
200 LA 41	13.00	1490	27.00	89.1	0.78	83.3	11.4	2.5	72	0.3184	515	300	400	140	150	0.25760
	4.33	493	20.57	74.1	0.41	83.9	3.6	2.4								
200 LB 41	16.00	1490	36.34	89.5	0.71	102.5	10.0	2.8	72	0.3184	515	300	400	140	150	0.25760
	5.33	491	27.78	71.0	0.39	103.7	3.8	2.7								
225 S 41	18.00	1475	38.90	90.0	0.64	116.4	11.6	3.8	73	0.7737	750	600	800	140	150	0.38570
	6.00	485	22.30	78.0	0.50	119.6	1.9	2.7								
225 M 41	20.00	1470	42.53	91.0	0.75	129.9	10.6	3.4	73	0.7737	750	600	800	140	150	0.45990
	6.67	480	22.99	79.0	0.53	132.7	1.7	2.7								
250 M 41	29.00	1490	51.01	92.2	0.89	185.9	10.5	2.8	75	1.2300	905	600	800	140	100	0.77930
	9.50	495	33.77	84.6	0.48	183.3	4.8	2.3								
250 ML 41	○	○	○	○	○	○	○	○	○	○	○	○	○	○	○	○
280 S 41	○	○	○	○	○	○	○	○	○	○	○	○	○	○	○	○
280 M 41	○	○	○	○	○	○	○	○	○	○	○	○	○	○	○	○
315 S 41	○	○	○	○	○	○	○	○	○	○	○	○	○	○	○	○

○ I dati non indicati sono forniti su richiesta
Data not indicated is supplied on request

Les données qui ne sont pas indiquées sont fournies sur demande
Die nicht angegebenen Daten werden auf Anfrage geliefert
Los datos que no se han precisado se pueden comunicar cuando se solicite

● Numero di avviamenti superiori su richiesta
Higher number of start-ups by request
Nombre de démarrages supérieurs sur demande
Höhere Anzahl von Starts pro Stunde auf Anfrage
Número de arranques superiores a petición

$$I'_n = I_n \cdot \frac{400}{U'} \quad (I'_n = \text{corrente a } U' \text{ Volt}; \\ I'_n = \text{current at } U' \text{ Volt}; \\ I'_n = \text{intensité à } U' \text{ Volt}; \\ I'_n = \text{Strom mit } U' \text{ Volt}; \\ I'_n = \text{corriente de } U' \text{ Voltios};)$$

$$J = \frac{PD^2}{4}$$

ITALIANO	Motori trifase con freno	Velocità	giri/min	Servizio tipo	per sollevamento	Freno
ENGLISH	Three-phase motors with brake	Speeds	rpm	Duty type	or hoist applications	Brake
FRANÇAIS	Moteurs triphasés avec frein	Vitesses	tours/min	Service type	pour levage	Frein
DEUTSCH	4. Drehstrom Motoren mit Bremse	Drehzahlen	1500 U/min	Betrieb	S4	Bremse
ESPAÑOL	4.6 Motores trifásicos con freno	2 Velocidades	375 rev/min	Régimen	40%	Freno

Tipo motore	Potenza resa	Velocità	Corrente	Rendimento	Fattore potenza	Coppia	Corrente avviamento	Coppia avviamento	Rumorosità	Momento d'inerzia	Massa	Coppia	Potenza	Frenate per ora	Inerzia totale
Motor type	Rated output	Speed	Current	Efficiency	Power factor	Torque	Starting current	Starting torque	Noise level	Moment of inertia	Mass	Torque	Power	Braking: n° per hour	Total inertia
Moteur type	Puissance mécanique	Vitesse	Intensité	Rendement	Facteur de puissance	Couple	Intensité démarrage	Couple démarrage	Niveau de bruit	Moment d'inertie	Masse	Couple	Puissance	Freinages par heure	Inertie totale
Motor Typ	Leistung	Drehzahl	Strom	Wirkungsgrad	Leistungsfaktor	Moment	Anlaufstrom	Anlaufmoment	Schalldruckpegel	Trägheitsmoment	Masse	Moment	Leistung	Bremsungen pro Stunde	Gesamt Trägheit
Tipo de motor	Potencia proporcionada	Velocidad	Corriente	Rendimiento	Factor de potencia	Par	Corriente de arranque	Par de arranque	Nivel de ruido	Momento de inercia	Peso	Par	Potencia	Frenados por hora	Inercia total
	P _n [KW]	n [1/min]	I _n ^P [A]	η [%]	cos φ	M _n [Nm]	I _a /I _n	M _a /M _n	[dB(A)] L _p	J [▼] [kgm ²]	m [kg]	[Nm] S1 S4	[VA/W]	[max n.] ●	[kgm ²]
132 S 43	2.20 0.55	1475 355	5.79 4.54	78.3 39.7	0.70 0.44	14.2 14.8	7.3 1.8	2.4 2.0	○	○	134	60 90	400	240	0.02908
132 M 43	3.50 0.88	1470 345	10.04 5.51	68.0 48.0	0.74 0.48	22.7 24.4	5.8 2.7	2.6 1.7	○	○	134	60 90	400	240	0.03648
132 L 43	4.00 1.00	1475 355	10.44 6.93	77.9 43.4	0.71 0.48	25.9 26.9	6.7 1.9	2.0 2.1	○	○	134	60 90	400	240	0.04458
160 M 43	5.50 1.38	1485 364	14.80 9.76	78.9 55.7	0.68 0.37	35.4 36.2	9.7 2.3	3.1 1.8	○	○	217	90 130	480	240	0.06771
160 L 43	7.50 1.90	1480 358	16.94 9.67	83.0 63.0	0.77 0.45	48.4 50.7	7.2 2.2	2.3 1.6	○	○	217	90 130	480	240	0.08511
180 L 43	9.50 2.40	1475 365	19.26 19.09	89.0 55.0	0.80 0.33	61.5 62.8	9.3 2.6	2.8 2.9	70	0.2911	435	300 400	140	150	0.16130
200 LA 43	12.00 2.75	1490 365	26.21 18.85	89.3 56.9	0.74 0.37	76.9 71.9	9.4 1.7	3.5 2.0	72	0.2576	495	300 400	140	150	0.25760
200 LB 43	16.00 3.25	1490 365	34.40 21.47	89.5 57.5	0.75 0.38	102.5 85.0	10.6 1.9	4.0 2.1	72	0.2576	495	300 400	140	150	0.25760
225 M 43	18.50 4.65	1488 365	34.79 22.58	90.3 74.3	0.85 0.40	118.7 121.7	8.1 1.9	2.2 1.6	73	0.4599	750	600 800	140	150	0.45990
250 M 43	37.00 9.50	1490 360	65.03 42.68	94.4 71.4	0.87 0.45	237.1 252.0	9.9 2.2	2.6 1.7	75	0.7793	835	600 800	140	100	0.77930
280 S 43	○	○	○	○	○	○	○	○	○	○	○	○	○	○	○
280 M 43	○	○	○	○	○	○	○	○	○	○	○	○	○	○	○
315 S 43	○	○	○	○	○	○	○	○	○	○	○	○	○	○	○

○ I dati non indicati sono forniti su richiesta
Data not indicated is supplied on request

Les données qui ne sont pas indiquées sont fournies sur demande
Die nicht angegebenen Daten werden auf Anfrage geliefert

Los datos que no se han precisado se pueden comunicar cuando se solicite

● Numero di avviamenti superiori su richiesta
Higher number of start-ups by request

Nombre de démarrages supérieurs sur demande
Höhere Anzahl von Starts pro Stunde auf Anfrage

Número de arranques superiores a petición

$$I'_n = I_n \cdot \frac{400}{U'} \quad (I'_n = \text{corrente a } U' \text{ Volt});$$

(I_n = current at U' Volt);

(I_n = intensité à U' Volt);

(I_n = Strom mit U' Volt);

(I_n = corriente de U' Voltios);

$$J = \frac{PD^2}{4}$$

ITALIANO	Motori alimentati da inverter
ENGLISH	Motors energized by inverter
FRANÇAIS	Moteurs alimentés par variateur
DEUTSCH	4. Motoren mit Umrichterversorgung
ESPAÑOL	4.7 Motores alimentados con inverter

Ventilazione Ventilation Ventilation Belüftung Ventilación	IC 411						IC 411 / IC 416*						IC 416			IC 411						
	400 V, 50 Hz [1/min] 3000	[Hz] 5 ÷ 50 range 1 ÷ 10 [1/min] 300 ÷ 3000		[Hz] 10 ÷ 50 range 1 ÷ 5 [1/min] 600 ÷ 3000		[Hz] 25 ÷ 50 range 1 ÷ 2 [1/min] 1500 ÷ 3000		[Hz] 50 ÷ 87 range 10 ÷ 17 [1/min] 3000 ÷ 5200		[Hz] 50 ÷ 87 range 10 ÷ 17 [1/min] 3000 ÷ 5200		[Hz] 5 ÷ 50 range 1 ÷ 10 [1/min] 300 ÷ 3000		[Hz] 5 ÷ 50 range 1 ÷ 10 [1/min] 300 ÷ 3000								
Tipo motore	Alimentazione da rete	Coppia costante		Coppia costante		Coppia costante		Coppia costante - Flusso indebolito		Coppia costante - Flusso costante collegamento Δ		Coppia costante - Ventilazione Assistita		Coppia quadratica*								
Motor type	Mains connection	Constant torque		Constant torque		Constant torque		Constant torque - Weakened flux		Constant torque - Constant flux Δ connection		Constant torque - Forced Ventilation		Quadratic torque*								
Moteur type	Alimentation de secteur	Couple constant		Couple constant		Couple constant		Couple constant - Flux affaibli		Couple constant - Flux constant raccordement Δ		Couple constant - Ventilation Assistée		Couple quadratique*								
Motor Typ	Netzanschluss	Konstantes Gegenmoment		Konstantes Gegenmoment		Konstantes Gegenmoment		Konstantes Gegenmoment - Feldschwächbetrieb		Konstantes Gegenmoment - konstanter Strom Δ-Verbindung		Konstantes Gegenmoment - Fremdbelüftung		Quadratisches Gegenmoment*								
Tipo de motor	Alimentación desde la red	Par constante		Par constante		Par constante		Par constante - Flujo debilitado		Par constante - Flujo constante conexión Δ		Par constante - Ventilación asistida		Par cuadrático*								
Ex d - Ex de	P _n [kW]	I _n [A]	P [kW]	M [Nm]	I [A]	P [kW]	M [Nm]	I [A]	P [kW]	M [Nm]	I [A]	P [kW]	M [Nm]	I [A]	P [kW]							
63 B 2	0.25	0.85	0.02-0.16	0.54	0.53	0.04-0.18	0.61	0.60	0.11-0.22	0.76	0.74	0.13-0.23	0.46	0.44	0.21-0.36	0.70	1.18	---	---	---	0.25	
71 A 2	0.37	1.10	0.02-0.24	0.81	0.71	0.05-0.27	0.91	0.80	0.16-0.33	1.12	0.99	0.20-0.35	0.68	0.60	0.30-0.53	1.04	1.60	---	---	---	0.37	
71 B 2	0.55	1.40	0.04-0.35	1.19	0.91	0.08-0.40	1.34	1.02	0.24-0.49	1.65	1.26	0.30-0.51	1.00	0.76	0.45-0.79	1.53	2.02	---	---	---	0.55	
80 A 2	0.75	1.90	0.05-0.48	1.6	1.29	0.11-0.54	1.84	1.45	0.33-0.67	2.2	1.80	0.40-0.70	1.37	1.08	0.62-1.07	2.10	2.89	---	---	---	0.75	
80 B 2	1.10	2.60	0.07-0.70	2.38	1.67	0.16-0.79	2.67	1.88	0.49-0.98	3.31	2.32	0.59-1.03	1.99	1.40	0.90-1.57	3.05	3.73	---	---	---	1.10	
90 S 2	1.50	3.10	0.10-0.96	3.19	1.99	0.22-1.08	3.59	2.24	0.67-1.34	4.45	2.78	0.81-1.40	2.68	1.67	1.23-2.14	4.10	4.45	---	---	---	1.50	
90 L 2	2.20	4.80	0.14-1.41	4.77	3.08	0.32-1.58	5.36	3.47	0.98-1.96	6.64	4.29	1.18-2.06	4.00	2.59	1.81-3.15	6.12	6.88	---	---	---	2.20	
100 LA 2	3.00	7.30	0.19-1.92	6.41	4.67	0.43-2.16	7.21	5.26	1.34-2.67	8.93	6.51	1.61-2.80	5.38	3.92	2.47-4.29	8.23	10.44	0.27-2.70	9.02	6.57	3.00	
												[Hz] 50 ÷ 70 ★ range 10 ÷ 14 [1/min] 3000 ÷ 4200			[Hz] 50 ÷ 70 ★ range 10 ÷ 14 [1/min] 3000 ÷ 4200							
112 M 2	4.00	8.70	0.30-2.60	8.40	5.60	0.60-2.90	9.50	6.30	1.80-3.60	11.70	7.80	3.00-4.10	9.80	6.50	3.90-5.40	12.80	14.90	0.40-3.60	11.90	7.90	4.00	
132 SA 2	5.50	12.00	0.40-3.50	11.60	7.40	0.80-4.00	13.10	8.30	2.50-4.90	16.20	10.30	4.10-5.70	13.50	8.60	5.30-7.50	17.60	19.50	0.50-5.00	16.40	10.40	5.50	
132 SB 2	7.50	15.00	0.50-4.80	15.80	9.60	1.10-5.40	17.70	10.80	3.30-6.70	21.90	13.40	5.60-7.80	18.20	11.10	7.30-10.20	23.90	25.30	0.70-6.8	22.20	13.50	7.50	
132 MB 2	9.20	18.00	0.60-5.90	19.40	11.50	1.30-6.60	21.80	13.00	4.10-8.20	27.00	16.10	6.80-9.50	22.40	13.40	8.90-12.50	29.40	30.40	0.80-8.30	27.30	16.20	9.20	
160 MA 2	11.00	20.60	0.70-7.00	23.00	13.10	1.60-7.90	25.80	14.80	4.90-9.80	32.00	18.30	8.10-11.40	26.50	15.20	10.70-14.90	34.80	34.60	1.00-9.90	32.3	18.50	11.00	
160 MB 2	15.00	26.80	1.00-9.60	31.10	16.90	2.20-10.80	35.00	19.00	6.70-13.40	43.30	23.60	11.10-15.50	36.00	19.60	14.60-20.40	47.20	44.60	1.40-13.50	3.80	23.80	15.00	
160 L 2	18.50	32.80	1.20-11.80	38.40	20.90	2.70-13.30	43.20	23.50	8.20-16.50	53.50	29.00	13.70-19.20	44.40	24.10	17.90-25.10	58.20	55.00	1.70-16.70	54.00	29.30	18.50	
												[Hz] 50 ÷ 60 ★ range 10 ÷ 12 [1/min] 3000 ÷ 3600			[Hz] 50 ÷ 60 ★ range 10 ÷ 12 [1/min] 3000 ÷ 3600							
180 M 2	22.00	40.00	1.40-14.10	46.00	25.40	3.20-15.80	51.00	28.50	9.80-19.60	63.00	35.30	19.80-23.80	64.00	35.70	22.00-26.40	71.00	68.90	2.00-19.80	64.00	35.70	22.00	
200 LA 2	30.00	55.00	1.90-19.20	62.00	35.20	4.30-21.60	69.00	39.60	13.40-26.70	86.00	49.00	27.00-32.40	87.00	49.50	30.00-36.00	96.00	95.70	2.70-27.00	87.00	49.50	30.00	
200 LB 2	37.00	67.00	2.40-23.70	76.00	42.40	5.30-26.60	86.00	47.70	16.50-33.00	106.00	59.00	33.30-40.00	107.00	59.60	37.00-44.40	119.00	115.20	3.30-33.30	107.00	59.60	37.00	
225 M 2	45.00	82.00	2.90-28.80	92.00	52.00	6.50-32.40	104.00	58.50	20.00-40.10	129.00	72.30	40.50-48.60	130.00	73.10	42.70-51.30	137.00	134.20	4.10-40.50	130.00	73.10	45.00	
250 M 2	55.00	98.00	3.50-35.20	113.00	62.80	7.90-39.60	127.00	70.60	24.50-49.00	157.00	87.40	49.50-59.40	159.00	88.30	52.20-62.70	168.00	162.10	5.00-49.50	159.00	88.30	55.00	
280 S 2	75.00	132.00	4.60-46.40	149.00	81.00	10.10-50.70	163.00	88.50	31.70-63.40	203.00	110.70	63.70-76.50	204.00	111.30	67.50-81.00	216.00	205.00	6.40-63.70	204.00	111.30	73.50	
280 M 2	90.00	165.00	5.60-55.60	178.00	101.40	12.20-60.80	195.00	110.90	38.00-76.10	244.00	138.70	76.50-91.80	245.00	139.40	81.00-97.20	259.00	256.70	7.70-76.50	245.00	139.40	87.30	
315 S 2	110.00	139.00	6.80-68.00	218.00	118.50	14.90-74.40	238.00	129.60	46.50-91.00	298.00	162.10	93.50-112.20	300.00	163.00	99.00-118.80	317.00	300.10	9.40-93.50	300.00	163.00	105.60	
315 LA 2	132.00	222.00	8.20-81.60	262.00	140.70	17.90-89.20	287.00	153.90	55.80-111.60	359.00	192.40	112.20-134.60	361.00	193.40	118.80-142.50	382.00	356.20	11.20-112.20	361.00	193.40	124.10	
315 LB 2	160.00	269.00	9.90-98.90	317.00	166.00	21.60-108.20	346.00	181.50	67.60-135.30	433.00	227.00	136.00-163.20	435.00	228.20	144.00-172.80	461.00	420.30	13.60-136.00	435.00	228.20	147.20	
315 LC 2	200.00	332.00	12.40-123.60	396.00	206.00	27.00-135.20	433.00	225.30	84.50-169.10	541.00	281.70	170.00-204.00	544.00	283.20	180.00-216.00	576.00	521.50	17.00-170.00	544.00	283.00	180.00	

Valori arrotondati
Rounded values
Valeurs arrondies
Gerundete Werte
Valores redondeado

● Valori riferiti a 50 Hz
Values refer to 50 Hz
Valeurs se réfèrent à 50 Hz
Werte beziehen sich auf 50 Hz
Valores se refieren a 50 Hz Hz

◆ Si consiglia IC 416 per ridurre il rumore (disponibile da altezza d'asse 100)
To reduce noise level, IC 416 is advisable (available from frame size 100)
On conseille IC 416 pour réduire le bruit (disponible à partir de hauteur d'axe 100)
Zur Lärmverringerng wird IC 416 empfohlen (verfügbar ab Baugröße 100)
Se aconseja IC 416 para reducir el nivel de ruido (disponible a partir de altura del eje 100)

★ Frequenza superiore su richiesta
Higher frequency upon request
Fréquence supérieure sur demande
Auf Anfrage höhere Frequenz
Frecuencia mayor a petición del cliente

ITALIANO	Motori alimentati da inverter
ENGLISH	Motors energized by inverter
FRANÇAIS	Moteurs alimentés par variateur
DEUTSCH	4. Motoren mit Umrichterversorgung
ESPAÑOL	4.7 Motores alimentados con inverter

Ventilazione Ventilation Ventilation Belüftung Ventilación		IC 411									IC 411 / IC 416						IC 416			IC 411
400 V, 50 Hz [1/min] 1500		[Hz] 5 ÷ 50 range 1 ÷ 10 [1/min] 150 ÷ 1500			[Hz] 10 ÷ 50 range 1 ÷ 5 [1/min] 300 ÷ 1500			[Hz] 25 ÷ 50 range 1 ÷ 2 [1/min] 750 ÷ 1500			[Hz] 50 ÷ 87 range 10 ÷ 17 [1/min] 1500 ÷ 2600			[Hz] 50 ÷ 87 range 10 ÷ 17 [1/min] 1500 ÷ 2600			[Hz] 5 ÷ 50 range 1 ÷ 10 [1/min] 150 ÷ 1500			[Hz] 5 ÷ 50 range 1 ÷ 10 [1/min] 150 ÷ 1500
Tipo motore	Alimentazione da rete	Coppia costante			Coppia costante			Coppia costante			Coppia costante - Flusso indebolito			Coppia costante - Flusso costante collegamento Δ			Coppia costante - Ventilazione Assistita			Coppia quadratica*
Motor type	Mains connection	Constant torque			Constant torque			Constant torque			Constant torque - Weakened flux			Constant torque - Constant flux Δ connection			Constant torque - Forced Ventilation			Quadratic torque*
Moteur type	Alimentation de secteur	Couple constant			Couple constant			Couple constant			Couple constant - Flux affaibli			Couple constant - Flux constant raccordement Δ			Couple constant - Ventilations Assistée			Couple quadratique*
Motor Typ	Netzspeisung	Konstantes Gegenmoment			Konstantes Gegenmoment			Konstantes Gegenmoment			Konstantes Gegenmoment - Feldschwächbetrieb			Konstantes Gegenmoment - konstanter Strom Δ-Verbindung			Konstantes Gegenmoment - Fremdbelüftung			Quadratisches Gegenmoment*
Tipo de motor	Alimentación desde la red	Par constante			Par constante			Par constante			Par constante - Flujo debilitado			Par constante - Flujo constante conexión Δ			Par constante - Ventilación asistida			Par cuadrático*
Ex d - Ex de	P _n [kW]	I _n [A]	P [kW]	M [Nm]	I [A]	P [kW]	M [Nm]	I [A]	P [kW]	M [Nm]	I [A]	P [kW]	M [Nm]	I [A]	P [kW]	M [Nm]	I [A]	P [kW]		
63 A 4	0.12	0.62	0.01-0.08	0.53	0.34	0.02-0.09	0.60	0.38	0.05-0.11	0.74	0.48	0.06-0.11	0.45	0.29	0.10-0.17	0.68	0.76	---	0.12	
63 B 4	0.18	0.67	0.01-0.12	0.82	0.44	0.03-0.13	0.92	0.49	0.08-0.16	1.14	0.61	0.10-0.17	0.69	0.37	0.15-0.26	1.05	0.97	---	0.18	
71 A 4	0.25	0.80	0.02-0.16	1.11	0.49	0.04-0.18	1.25	0.56	0.11-0.22	1.55	0.69	0.13-0.23	0.93	0.41	0.21-0.36	1.43	1.10	---	0.25	
71 B 4	0.37	1.10	0.02-0.24	1.63	0.69	0.05-0.27	1.83	0.77	0.16-0.33	2.26	0.96	0.20-0.35	1.37	0.58	0.30-0.53	2.09	1.54	---	0.37	
80 A 4	0.55	1.60	0.04-0.35	2.44	1.04	0.08-0.40	2.74	1.17	0.24-0.49	3.39	1.44	0.30-0.51	2.04	0.87	0.45-0.79	3.13	2.32	---	0.55	
80 B 4	0.75	2.00	0.05-0.48	3.27	1.29	0.11-0.54	3.68	1.45	0.33-0.67	4.56	1.79	0.40-0.70	2.75	1.08	0.62-1.07	4.21	2.87	---	0.75	
90 S 4	1.10	2.80	0.07-0.70	4.80	1.75	0.16-0.79	5.40	1.97	0.49-0.98	6.69	2.43	0.59-1.03	4.03	1.47	0.90-1.57	6.17	3.91	---	1.10	
90 L 4	1.50	3.60	0.10-0.96	6.46	2.31	0.22-1.08	7.26	2.60	0.67-1.34	8.99	3.21	0.81-1.40	5.42	1.94	1.23-2.14	8.29	5.15	---	1.50	
100 LA 4	2.20	5.25	0.14-1.41	9.42	3.34	0.32-1.58	10.60	3.76	0.98-1.96	13.12	4.65	1.18-2.06	7.91	2.80	1.81-3.15	12.10	7.46	0.20-1.98	2.20	
100 LB 4	3.00	6.83	0.19-1.92	12.77	4.34	0.43-2.16	14.36	4.88	1.34-2.67	17.78	6.04	1.61-2.80	10.71	3.64	2.47-4.29	16.40	9.68	0.27-2.70	3.00	
112 M 4	4.00	8.20	0.30-2.60	17.00	5.10	0.60-2.90	19.10	5.80	1.80-3.60	23.60	7.20	2.20-3.70	14.30	4.30	3.30-5.70	21.80	11.50	0.40-3.60	4.00	
132 SB 4	5.50	11.60	0.40-3.50	23.10	7.40	0.80-4.00	26.00	8.30	2.50-4.90	32.20	10.30	3.00-5.10	19.40	6.20	4.50-7.90	29.70	16.50	0.50-5.00	5.50	
132 MB 4	7.50	16.50	0.50-4.80	31.60	10.50	1.10-5.40	35.60	11.80	3.30-6.70	44.00	14.60	4.00-7.00	26.50	8.80	6.20-10.70	40.60	23.30	0.70-6.80	7.50	
132 ML 4	8.80	18.50	0.60-5.60	37.00	11.80	1.30-6.30	41.60	13.30	3.90-7.80	51.50	16.50	4.70-8.20	31.00	9.90	7.20-12.60	47.50	26.40	0.80-7.90	8.80	
160 MB 4	11.00	23.00	0.70-7.00	45.70	14.60	1.60-7.90	51.50	16.50	4.90-9.80	63.70	20.40	5.90-10.30	38.40	12.30	9.00-15.70	58.70	32.70	1.00-9.90	11.00	
160 L 4	15.00	30.00	1.00-9.60	62.40	19.10	2.20-10.80	70.20	21.50	6.70-13.40	86.80	26.70	8.10-14.00	52.30	16.10	12.30-21.50	80.10	42.80	1.40-13.50	15.00	
180 M 4	18.50	39.00	1.20-11.80	77.00	25.00	2.70-13.30	87.00	28.20	8.20-16.50	107.00	34.90	9.90-17.30	65.00	21.00	15.20-26.50	99.00	55.90	1.70-16.70	18.50	
180 L 4	22.00	44.00	1.40-14.10	92.00	28.30	3.20-15.80	103.00	31.90	9.80-19.60	127.00	39.40	11.80-20.60	77.00	23.80	18.10-31.50	118.00	63.30	2.00-19.80	22.00	
200 LB 4	30.00	54.00	1.90-19.20	124.00	34.30	4.30-21.60	140.00	38.60	13.40-26.70	173.00	47.80	16.10-28.00	104.00	28.80	24.70-42.90	160.00	76.60	2.70-27.00	30.00	
225 S 4	37.00	70.00	2.40-23.70	153.00	44.60	5.30-26.60	172.00	50.20	16.50-33.00	213.00	62.20	19.90-34.60	128.00	37.50	28.90-50.30	186.00	94.70	3.30-33.30	37.00	
225 M 4	45.00	82.00	2.90-28.80	186.00	52.70	6.50-32.40	209.00	59.30	20.00-40.10	259.00	73.40	24.20-42.00	156.00	44.20	35.10-61.10	227.00	111.90	4.10-40.50	45.00	
250 M 4	55.00	96.00	3.50-35.20	226.00	61.40	7.90-39.60	255.00	69.10	24.50-49.00	315.00	85.50	29.50-51.40	190.00	51.50	42.90-74.70	276.00	130.30	5.00-49.50	55.00	
280 S 4	75.00	136.00	4.80-48.00	310.00	86.60	10.50-52.50	339.00	94.70	32.20-64.50	416.00	116.40	33.70-58.70	218.00	60.90	58.60-101.90	378.00	183.80	6.60-66.00	75.00	
280 M 4	90.00	163.00	5.80-57.60	370.00	103.90	12.60-63.00	405.00	113.70	38.70-77.40	498.00	139.70	40.50-70.50	261.00	73.10	70.30-122.30	452.00	220.50	7.90-79.20	90.00	
315 S 4	110.00	199.00	7.00-70.40	453.00	127.20	15.40-77.00	495.00	139.10	47.30-94.60	608.00	170.90	49.50-86.10	318.00	89.40	85.90-149.40	552.00	269.80	9.70-96.80	110.00	
315 LA 4	132.00	239.00	8.50-84.50	543.00	154.20	18.50-92.40	594.00	168.70	56.80-113.50	730.00	207.20	59.40-103.30	382.00	108.40	103.10-179.30	663.00	327.30	11.60-116.10	132.00	
315 LB 4	160.00	282.00	10.20-102.40	657.00	179.90	22.40-112.00	719.00	196.80	68.80-137.60	883.00	241.80	72.00-125.30	462.00	126.50	124.90-217.40	802.00	381.80	14.10-140.80	160.00	
315 LC 4	200.00	354.00	12.80-128.00	822.00	225.60	28.00-140.00	899.00	246.80	86.00-172.00	1104.00	303.20	90.00-156.60	578.00	158.60	156.20-271.70	1002.00	478.80	17.60-176.00	200.00	

Valori arrotondati
Rounded values
Valeurs arrondies
Gerundete Werte
Valores redondeado

●
Valori riferiti a 50 Hz
Values refer to 50 Hz
Valeurs se réfèrent à 50 Hz
Werte beziehen sich auf 50 Hz
Valores se refieren a 50 Hz

ITALIANO	Motori alimentati da inverter
ENGLISH	Motors energized by inverter
FRANÇAIS	Moteurs alimentés par variateur
DEUTSCH	4. Motoren mit Umrichterversorgung
ESPAÑOL	4.7 Motores alimentados con inverter

Ventilazione Ventilation Ventilation Belüftung Ventilación		IC 411						IC 411 / IC 416						IC 416			IC 411				
400 V, 50 Hz [1/min] 1000		[Hz] 5 ÷ 50 range 1 ÷ 10 [1/min] 100 ÷ 1000		[Hz] 10 ÷ 50 range 1 ÷ 5 [1/min] 200 ÷ 1000		[Hz] 25 ÷ 50 range 1 ÷ 2 [1/min] 500 ÷ 1000		[Hz] 50 ÷ 87 range 10 ÷ 17 [1/min] 1000 ÷ 1750		[Hz] 50 ÷ 87 range 10 ÷ 17 [1/min] 1000 ÷ 1750		[Hz] 5 ÷ 50 range 1 ÷ 10 [1/min] 100 ÷ 1000			[Hz] 5 ÷ 50 range 1 ÷ 10 [1/min] 100 ÷ 1000						
Tipo motore	Alimentazione da rete	Coppia costante		Coppia costante		Coppia costante		Coppia costante - Flusso indebolito		Coppia costante - Flusso costante collegamento Δ		Coppia costante - Ventilazione Assistita			Coppia quadratica*						
Motor type	Mains connection	Constant torque		Constant torque		Constant torque		Constant torque - Weakened flux		Constant torque - Constant flux Δ connection		Constant torque - Forced Ventilation			Quadratic torque*						
Moteur type	Alimentation de secteur	Couple constant		Couple constant		Couple constant		Couple constant - Flux affaibli		Couple constant - Flux constant raccordement Δ		Couple constant - Ventilazione Assistée			Couple quadratique*						
Motor Typ	Netzanschluss	Konstantes Gegenmoment		Konstantes Gegenmoment		Konstantes Gegenmoment		Konstantes Gegenmoment - Feldschwächbetrieb		Konstantes Gegenmoment - konstanter Strom Δ-Verbindung		Konstantes Gegenmoment - Fremdbelüftung			Quadratisches Gegenmoment*						
Tipo de motor	Alimentación desde la red	Par constante		Par constante		Par constante		Par constante - Flujo debilitado		Par constante - Flujo constante conexión Δ		Par constante - Ventilación asistida			Par cuadrático*						
Ex d - Ex de	P _n [kW]	I _n [A]	P [kW]	M [Nm]	I [A]	P [kW]	M [Nm]	I [A]	P [kW]	M [Nm]	I [A]	P [kW]	M [Nm]	I [A]	P [kW]						
63 B 6	0.09	0.65	0.01-0.06	0.65	0.42	0.01-0.06	0.73	0.47	0.04-0.08	0.90	0.59	0.05-0.08	0.54	0.35	0.07-0.13	0.83	0.94	---	---	---	0.09
71 A 6	0.18	0.92	0.01-0.12	1.18	0.70	0.03-0.13	1.33	0.79	0.08-0.16	1.65	0.97	0.10-0.17	0.99	0.59	0.15-0.26	1.52	1.56	---	---	---	0.18
71 B 6	0.26	1.00	0.02-0.17	1.73	0.64	0.04-0.19	1.95	0.71	0.12-0.23	2.41	0.88	0.14-0.24	1.45	0.53	0.21-0.37	2.22	1.42	---	---	---	0.26
80 A 6	0.37	1.60	0.02-0.24	2.43	1.02	0.05-0.27	2.74	1.14	0.16-0.33	3.39	1.41	0.20-0.35	2.04	0.85	0.30-0.53	3.12	2.27	---	---	---	0.37
80 B 6	0.55	1.80	0.04-0.35	3.61	1.12	0.08-0.40	4.07	1.26	0.24-0.49	5.03	1.55	0.30-0.51	3.03	0.94	0.45-0.79	4.64	2.49	---	---	---	0.55
90 S 6	0.75	2.20	0.05-0.48	5.04	1.39	0.11-0.54	5.67	1.57	0.33-0.67	7.01	1.94	0.40-0.70	4.23	1.17	0.62-1.07	6.47	3.11	---	---	---	0.75
90 L 6	1.10	3.20	0.07-0.70	7.19	2.00	0.16-0.79	8.09	2.25	0.49-0.98	10.01	2.79	0.59-1.03	6.03	1.68	0.90-1.57	9.24	4.47	---	---	---	1.10
100 LB 6	1.50	3.80	0.10-0.96	9.65	2.43	0.22-1.07	10.86	2.73	0.67-1.34	13.44	3.38	0.81-1.40	8.10	2.04	1.23-2.14	12.39	5.43	0.13-1.35	13.57	3.42	1.50
112 M 6	2.20	6.20	0.10-1.40	14.00	3.90	0.30-1.60	15.80	4.40	1.00-2.00	19.50	5.40	1.20-2.10	11.80	3.30	1.80-3.20	18.00	8.70	0.20-2.00	19.70	5.50	2.20
132 S 6	3.00	8.50	0.20-1.90	19.30	5.40	0.40-2.20	21.70	6.10	1.30-2.70	26.90	7.60	1.60-2.80	16.20	4.60	2.50-4.30	24.80	12.10	0.30-2.70	27.20	7.60	3.00
132 M 6	4.00	9.50	0.30-2.60	25.20	6.10	0.60-2.90	28.40	6.80	1.80-3.60	35.10	8.50	2.20-3.70	21.20	5.10	3.30-5.70	32.40	13.60	0.40-3.60	35.40	8.60	4.00
132 ML 6	5.50	12.00	0.40-3.50	35.00	7.70	0.80-4.00	39.40	8.60	2.50-4.90	48.80	10.70	3.00-5.10	29.40	6.40	4.50-7.90	45.00	17.10	0.50-5.00	49.20	10.80	5.50
160 MB 6	7.50	16.00	0.50-4.80	48.30	10.20	1.10-5.40	54.30	11.50	3.30-6.70	67.20	14.20	4.00-7.00	40.50	8.50	6.20-10.70	62.00	22.70	0.70-6.80	67.90	14.30	7.50
160 L 6	11.00	23.00	0.70-7.00	70.80	14.80	1.60-7.90	79.60	16.60	4.90-9.80	98.50	20.50	5.90-10.30	59.40	12.40	9.00-15.70	91.00	33.00	1.00-9.90	99.50	20.80	11.00
180 L 6	15.00	29.00	1.00-9.60	96.00	18.30	2.20-10.80	107.00	20.60	6.70-13.40	133.00	25.50	8.10-14.00	80.00	15.40	12.30-21.50	123.00	40.90	1.40-13.50	134.00	25.70	15.00
200 LA 6	18.50	38.00	1.20-11.80	116.00	24.40	2.70-13.30	130.00	27.40	8.20-16.50	161.00	34.00	9.90-17.30	97.00	20.50	15.20-26.50	149.00	54.50	1.70-16.70	163.00	34.30	18.50
200 LB 6	22.00	44.00	1.40-14.10	137.00	28.30	3.20-15.80	154.00	31.90	9.80-19.60	191.00	39.40	11.80-20.60	115.00	23.80	18.10-31.50	176.00	63.30	2.00-18.80	193.00	39.80	22.00
225 M 6	30.00	61.00	1.90-19.20	186.00	38.60	4.30-21.60	209.00	43.40	13.40-26.70	259.00	53.80	16.10-28.00	156.00	32.40	23.40-40.80	227.00	81.90	2.70-27.00	262.00	54.30	30.00
250 M 6	37.00	72.00	2.40-23.70	228.00	46.00	5.30-26.60	257.00	51.80	16.50-33.00	318.00	64.10	19.90-34.60	192.00	38.60	28.90-50.30	279.00	97.70	3.30-33.30	321.00	64.70	37.00
280 S 6	45.00	90.50	2.90-28.80	280.00	58.40	6.30-31.50	306.00	63.80	19.40-38.70	376.00	78.40	20.30-35.20	197.00	41.00	35.10-61.10	342.00	123.90	4.00-39.60	385.00	80.30	45.00
280 M 6	55.00	109.00	3.50-35.20	343.00	68.90	7.70-38.50	375.00	75.40	23.70-47.30	461.00	92.60	24.70-43.10	241.00	48.50	43.00-74.70	419.00	146.20	4.80-48.40	472.00	94.80	55.00
315 S 6	75.00	147.20	4.80-48.00	463.00	93.30	10.50-52.50	506.00	102.00	32.20-64.50	22.00	125.30	33.70-58.70	326.00	65.60	58.60-101.90	565.00	197.90	6.60-66.00	637.00	128.30	75.00
315 LA 6	90.00	167.60	5.80-57.60	558.00	111.90	12.60-63.00	611.00	122.40	38.70-77.40	750.00	150.40	40.50-70.50	393.00	78.70	70.30-122.30	681.00	237.50	7.90-79.20	768.00	153.90	90.00
315 LB 6	110.00	205.00	7.00-70.40	676.00	130.20	15.40-77.00	740.00	142.40	47.30-94.60	909.00	175.00	49.50-86.10	476.00	91.60	85.90-149.40	825.00	276.30	9.70-96.80	930.00	179.00	110.00
315 LC 6	132.00	243.00	8.50-84.50	811.00	156.30	18.50-92.40	887.00	170.90	56.80-113.50	1090.00	210.00	59.40-103.30	570.00	109.90	103.10-179.30	989.00	331.60	11.60-116.10	1115.00	214.90	132.00

Valori arrotondati
Rounded values
Valeurs arrondies
Gerundete Werte
Valores redondeado

●
Valori riferiti a 50 Hz
Values refer to 50 Hz
Valeurs se réfèrent à 50 Hz
Werte beziehen sich auf 50 Hz
Valores se refieren a 50 Hz Hz

ITALIANO	Motori alimentati da inverter
ENGLISH	Motors energized by inverter
FRANÇAIS	Moteurs alimentés par variateur
DEUTSCH	4. Motoren mit Umrichterversorgung
ESPAÑOL	4.7 Motores alimentados con inverter

Ventilazione Ventilation Ventilation Belüftung Ventilación		IC 411						IC 411 / IC 416						IC 416			IC 411				
400 V, 50 Hz [1/min] 750		[Hz] 5 ÷ 50 range 1 ÷ 10 [1/min] 75 ÷ 750		[Hz] 10 ÷ 50 range 1 ÷ 5 [1/min] 150 ÷ 750		[Hz] 25 ÷ 50 range 1 ÷ 2 [1/min] 375 ÷ 750		[Hz] 50 ÷ 87 range 10 ÷ 17 [1/min] 750 ÷ 1300		[Hz] 50 ÷ 87 range 10 ÷ 17 [1/min] 750 ÷ 1300		[Hz] 5 ÷ 50 range 1 ÷ 10 [1/min] 75 ÷ 750			[Hz] 5 ÷ 50 range 1 ÷ 10 [1/min] 75 ÷ 750						
Tipo motore	Alimentazione da rete	Coppia costante		Coppia costante		Coppia costante		Coppia costante - Flusso indebolito		Coppia costante - Flusso costante collegamento Δ		Coppia costante - Ventilazione Assistita			Coppia quadratica*						
Motor type	Mains connection	Constant torque		Constant torque		Constant torque		Constant torque - Weakened flux		Constant torque - Constant flux Δ connection		Constant torque - Forced Ventilation			Quadratic torque*						
Moteur type	Alimentation de secteur	Couple constant		Couple constant		Couple constant		Couple constant - Flux affaibli		Couple constant - Flux constant raccordement Δ		Couple constant - Ventilation Assistée			Couple quadratique*						
Motor Typ	Netzspeisung	Konstantes Gegenmoment		Konstantes Gegenmoment		Konstantes Gegenmoment		Konstantes Gegenmoment - Feldschwächbetrieb		Konstantes Gegenmoment - konstanter Strom Δ-Verbindung		Konstantes Gegenmoment - Fremdbelüftung			Quadratisches Gegenmoment*						
Tipo de motor	Alimentación desde la red	Par constante		Par constante		Par constante		Par constante - Flujo debilitado		Par constante - Flujo constante conexión Δ		Par constante - Ventilación asistida			Par cuadrático*						
Ex d - Ex de	P _n [kW]	I _n [A]	P [kW]	M [Nm]	I [A]	P [kW]	M [Nm]	I [A]	P [kW]	M [Nm]	I [A]	P [kW]	M [Nm]	I [A]	P [kW]						
63 B 8	0.05	0.44	0.003-0.03	0.52	0.29	0.01-0.04	0.58	0.32	0.02-0.04	0.72	0.40	0.03-0.05	0.43	0.24	0.04-0.07	0.67	0.64	---	---	---	0.05
71 B 8	0.15	0.57	0.01-0.10	1.53	0.34	0.02-0.11	1.72	0.38	0.07-0.13	2.13	0.48	0.08-0.14	1.28	0.29	0.12-0.21	1.96	0.76	---	---	---	0.15
80 A 8	0.18	0.97	0.01-0.12	1.56	0.58	0.03-0.13	1.76	0.65	0.08-0.16	2.17	0.81	0.10-0.17	1.31	0.49	0.15-0.26	2.00	1.30	---	---	---	0.18
80 B 8	0.25	1.00	0.02-0.16	2.21	0.63	0.04-0.18	2.49	0.71	0.11-0.22	3.08	0.88	0.13-0.23	1.86	0.53	0.21-0.36	2.84	1.41	---	---	---	0.25
90 S 8	0.37	1.30	0.02-0.24	3.33	0.83	0.05-0.27	3.74	0.93	0.16-0.33	4.63	1.15	0.20-0.35	2.79	0.70	0.30-0.53	4.27	1.85	---	---	---	0.37
90 L 8	0.55	1.90	0.04-0.35	4.94	1.22	0.08-0.40	5.56	1.37	0.24-0.49	6.88	1.70	0.30-0.51	4.15	1.02	0.45-0.79	6.35	2.73	---	---	---	0.55
100 LA 8	0.75	2.90	0.05-0.48	6.37	1.85	0.11-0.54	7.16	2.08	0.33-0.67	8.86	2.57	0.40-0.70	5.34	1.55	0.62-1.07	8.18	4.12	0.07-0.67	8.95	2.60	0.75
100 LB 8	1.10	3.10	0.07-0.70	9.96	1.99	0.16-0.79	11.21	2.24	0.49-0.98	13.87	2.77	0.59-1.03	8.36	1.67	0.90-1.57	12.79	4.45	0.10-0.99	14.01	2.80	1.10
112 M 8	1.50	4.40	0.10-1.00	12.70	2.80	0.20-1.10	14.30	3.20	0.70-1.30	17.70	3.90	0.80-1.40	10.70	2.40	1.20-2.10	16.40	6.30	0.10-1.40	17.90	3.90	1.50
132 SB 8	2.20	6.50	0.10-1.40	18.70	4.10	0.30-1.60	21.00	4.60	1.00-2.00	26.00	5.70	1.20-2.10	15.70	3.40	1.80-3.20	24.00	9.20	0.20-2.00	26.30	5.80	2.20
132 ML 8	3.00	8.50	0.20-1.90	25.50	5.40	0.40-2.20	28.70	6.00	1.30-2.70	35.50	7.50	1.60-2.80	21.40	4.50	2.50-4.30	32.70	12.00	0.30-2.70	35.80	7.50	3.00
160 MA 8	4.00	9.70	0.30-2.60	34.10	6.20	0.60-2.90	38.30	7.00	1.80-3.60	47.40	8.60	2.20-3.70	28.60	5.20	3.30-5.70	43.70	3.90	0.40-3.60	47.90	8.70	4.00
160 MB 8	5.50	14.00	0.40-3.50	46.40	8.70	0.80-4.00	52.20	9.80	2.50-4.90	64.60	12.10	3.00-5.10	38.90	7.30	4.50-7.90	59.60	19.40	0.50-5.00	65.20	12.20	5.50
160 L 8	7.50	18.00	0.50-4.80	63.70	11.20	1.10-5.40	71.60	12.70	3.30-6.70	88.60	15.70	4.00-7.00	53.40	9.40	6.20-10.70	81.80	25.10	0.70-6.80	89.50	15.80	7.50
180 L 8	11.00	23.00	0.70-7.00	93.00	14.80	1.60-7.90	105.00	16.60	4.90-9.80	130.00	20.60	5.90-10.30	78.00	12.40	9.00-15.70	120.00	33.00	1.00-9.90	131.00	20.80	11.00
200 LB 8	15.00	35.00	0.70-7.00	125.00	22.20	2.20-10.80	140.00	25.00	6.70-13.40	174.00	31.00	8.10-14.00	105.00	18.70	12.30-21.50	160.00	49.7	1.40-13.50	175.00	31.30	15.00
225 S 8	18.50	42.25	1.20-11.80	155.00	24.60	2.70-13.30	174.00	27.70	8.20-16.50	213.00	34.20	9.90-17.30	130.00	20.60	14.40-25.10	189.00	52.20	1.70-16.70	218.00	34.60	18.50
225 M 8	22.00	46.00	1.40-14.10	184.00	29.20	3.20-15.80	207.00	32.90	9.80-19.60	256.00	40.70	11.80-20.60	155.00	24.50	17.20-29.90	225.00	62.00	2.00-19.80	259.00	41.10	22.00
250 M 8	30.00	61.00	1.90-19.20	248.00	38.80	4.30-21.60	279.00	43.60	13.40-26.70	345.00	54.00	16.10-28.00	208.00	32.50	23.40-40.80	302.00	82.30	2.70-27.00	348.00	54.50	30.00
280 S 8	37.00	71.00	2.40-23.70	310.00	44.20	5.20-25.90	339.00	48.30	15.90-31.80	416.00	59.30	16.70-29.00	218.00	31.00	28.90-50.30	378.00	93.70	3.30-32.60	426.00	60.70	37.00
280 M 8	45.00	83.00	2.90-28.80	372.00	53.30	6.30-31.50	407.00	58.30	19.40-38.70	500.00	71.60	20.30-35.20	262.00	37.50	35.10-61.10	454.00	113.00	4.00-39.60	512.00	73.20	45.00
315 S 8	55.00	113.50	3.50-35.20	453.00	71.90	7.70-38.50	496.00	78.60	23.70-47.30	609.00	96.60	24.70-43.10	319.00	50.50	42.90-74.70	553.00	152.50	4.80-48.40	623.00	98.80	55.00
315 LA 8	75.00	136.60	4.80-48.00	624.00	90.80	10.50-52.50	682.00	99.40	32.20-64.50	838.00	122.10	33.70-58.70	439.00	63.90	58.60-101.90	761.00	192.70	6.60-66.00	858.00	124.90	75.00
315 LB 8	90.00	164.50	5.80-57.60	739.00	104.20	12.60-63.00	809.00	113.90	38.70-77.40	994.00	140.00	40.50-70.50	520.00	73.20	70.30-122.30	902.00	221.00	7.90-79.20	1017.00	143.20	90.00
315 LC 8	110.00	102.00	7.00-70.40	905.00	128.70	15.40-77.00	990.00	140.70	47.30-94.60	1216.00	172.90	49.50-86.10	636.00	90.50	85.90-149.40	1104.00	273.00	9.70-96.80	1244.00	176.90	110.00

Valori arrotondati
Rounded values
Valeurs arrondies
Gerundete Werte
Valores redondeado

● Valori riferiti a 50 Hz
Values refer to 50 Hz
Valeurs se réfèrent à 50 Hz
Werte beziehen sich auf 50 Hz
Valores se refieren a 50 Hz Hz

2 poli - pole - pôles - polig - polos

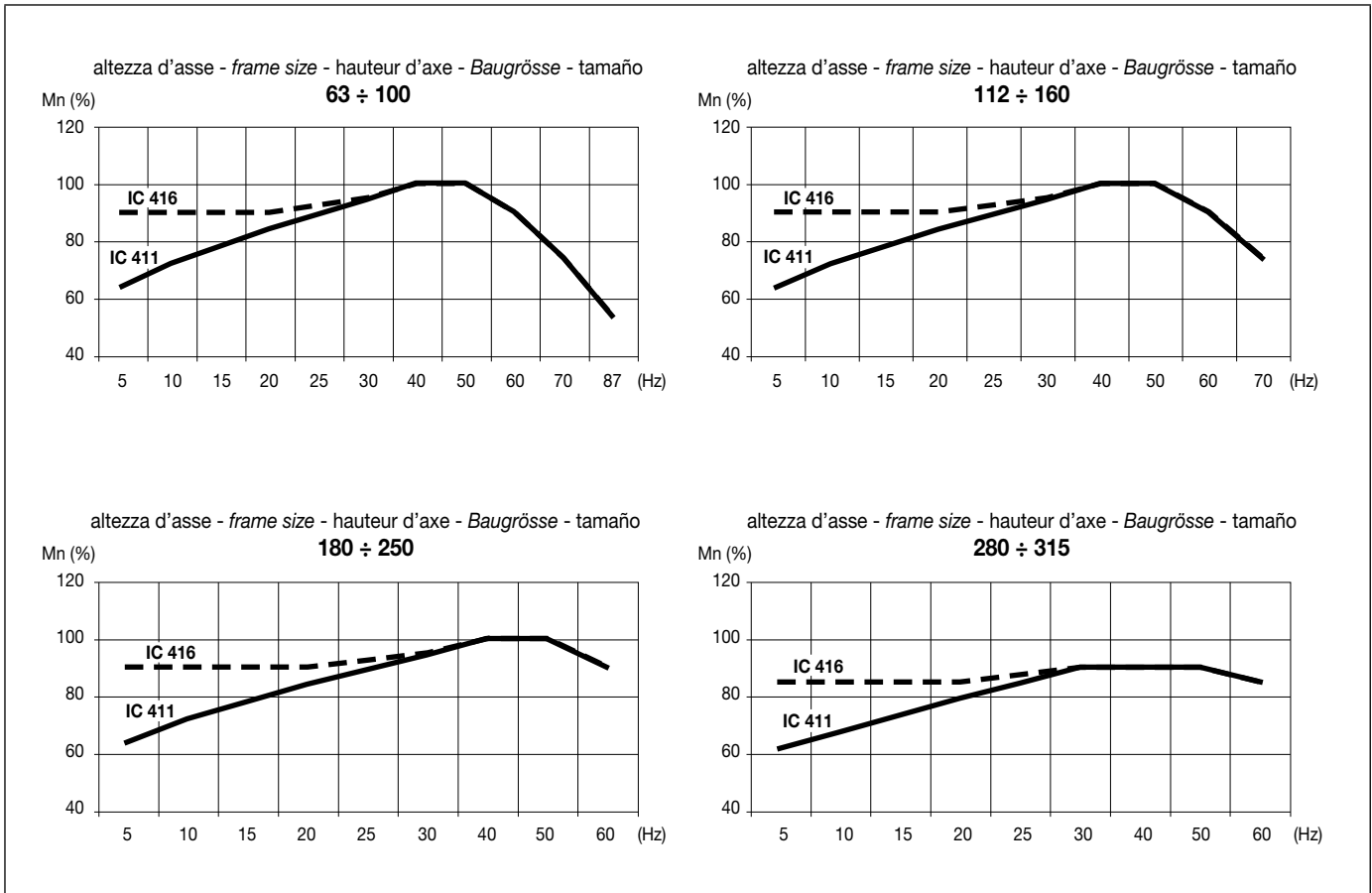

4 - 6 - 8 poli - pole - pôles - polig - polos

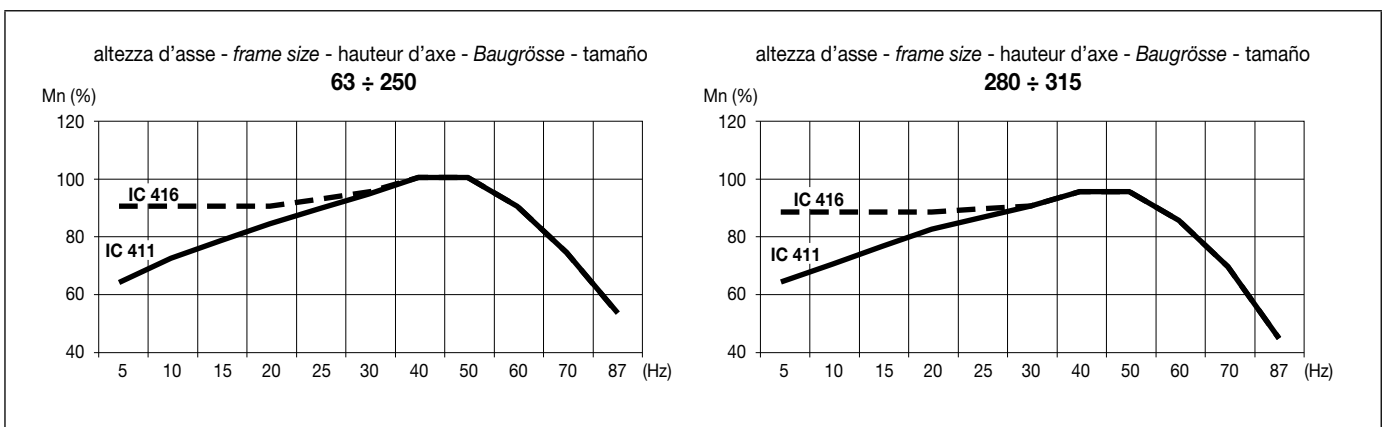

Mn (%)	(Hz)	IC 411	IC 416
Coppia	Frequenza	Autoventilati	Ventilazione assistita (disponibile da altezza d'asse 100)
Torque	Frequency	Self-ventilated	Forced ventilation (available from frame size 100)
Couple	Fréquence	Autoventilés	Ventilation assistée (disponible à partir de hauteur d'axe 100)
Moment	Frequenz	Eigenbelüftet	Fremdbelüftung (verfügbar ab Baugröße 100)
Par	Frecuencia	Autoventilados	Ventilacion asistida (disponible a partir de altura del eje 100)

2 poli - pole - pôles - polig - polos

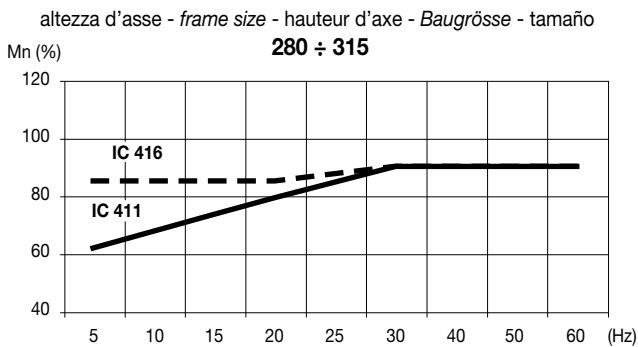
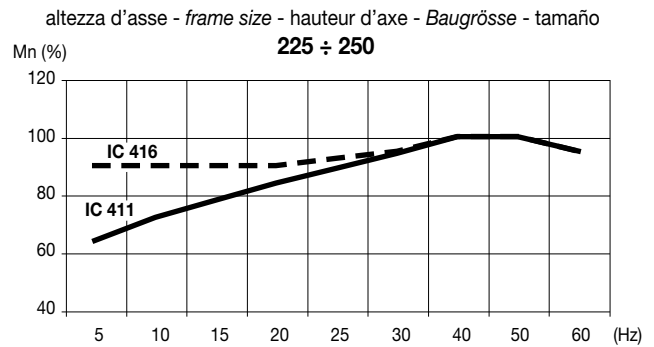
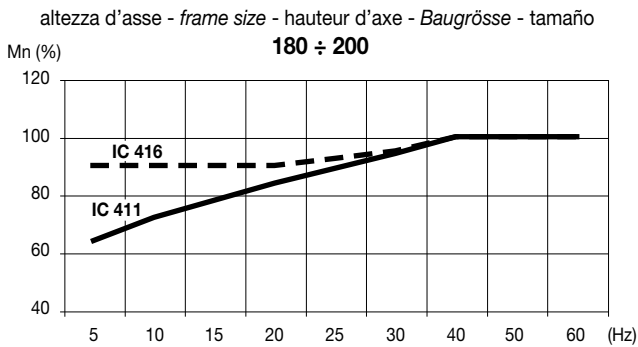
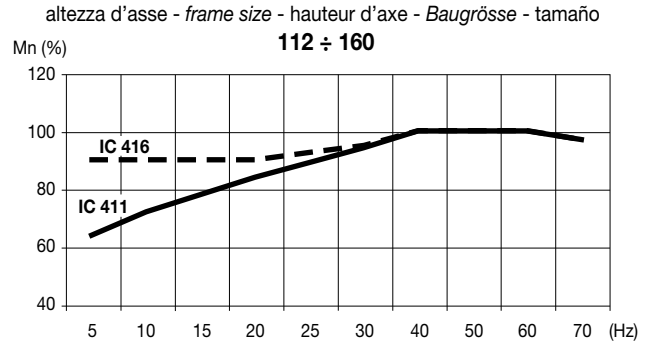
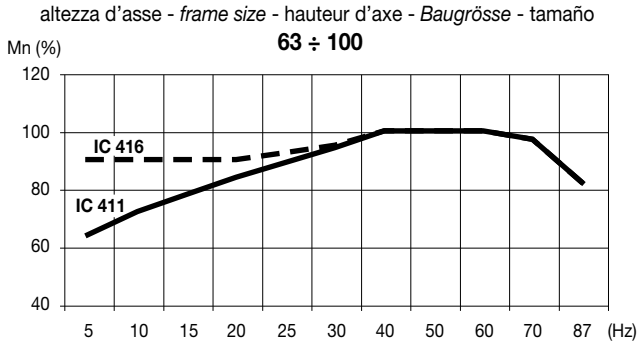

Note:

Nel funzionamento a coppia costante il valore di coppia utilizzabile è il valore minore del range di funzionamento prescelto

In the constant torque operating mode, the usable torque value is the lowest value of the chosen range of operation

Lors du fonctionnement à couple constant la valeur de couple utilisable est la valeur inférieure à la plage de fonctionnement sélectionnée

Im Betrieb mit konstantem Drehmoment ist der verwendbare Momentwert der Mindestwert des gewählten Betriebsbereichs

En el funcionamiento con par constante el valor de par que se puede utilizar es el valor menor del intervalo de funcionamiento elegido

Il valore di coppia di riferimento (Mn) è quello indicato nelle tabelle della sezione 4.1

The reference torque value (Mn) is the value indicated in the tables in section 4.1

La valeur de couple de référence (Mn) est celle indiquée dans les tableaux de la section 4.1

Der Richtwert des Drehmoments (Mn) ist der in den Tabellen in Abschnitt 4.1 angegebene

El valor de par de referencia (Mn) es el que recogen las tablas de la sección 4.1

ITALIANO	Motori alimentati da inverter - Curve di caricabilità	Coppia variabile flusso indebolito
ENGLISH	Motors energized by inverter - Load capacity curves	Variable torque - Weakened flux
FRANÇAIS	Moteurs alimentés par variateur - Courbes de chargeabilité	Couple variable flux affaibli
DEUTSCH	Motoren mit Umrichterversorgung - Belastungskurven	Variables Drehmoment mit Feldschwächbetrieb
ESPAÑOL	Motores alimentados con inverter - Curvas de capacidad de carga	Par variable flujo debilitado

4.
4.7.1

4 - 6 - 8 poli - pole - pôles - polig - polos

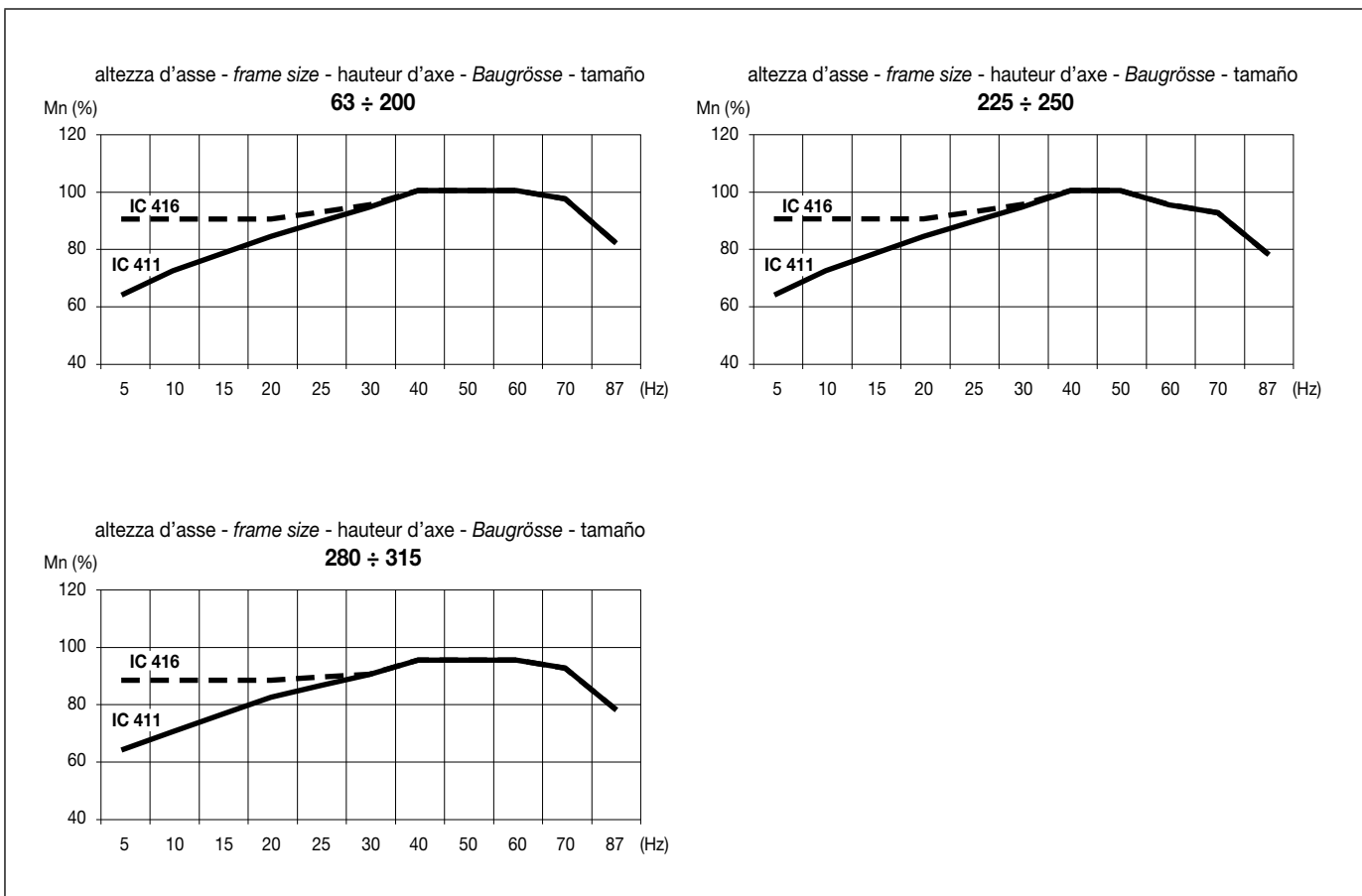

	Motori alimentati da inverter - Curve di caricabilità	Coppia variabile flusso indebolito
	Motors energized by inverter - Load capacity curves	Variable torque - Weakened flux
	Moteurs alimentés par variateur - Courbes de chargeabilité	Couple variable flux affaibli
4.	Motoren mit Umrichterversorgung - Belastungskurven	Variables Drehmoment mit Feldschwächbetrieb
4.7.2	Motores alimentados con inverter - Curvas de capacidad de carga	Par variable flujo debilitado

4 - 6 - 8 poli - pole - pôles - polig - polos

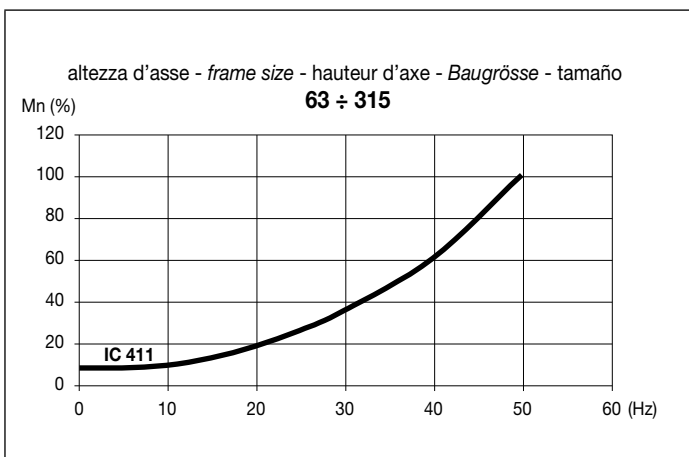

Note:
vedi pagina 192, 193;
see page 192, 193;
voir page 192, 193;
siehe Seite 192, 193;
véase página 192, 193;

5. Dimensioni d'ingombro e forme costruttive

- 5.1** Forme costruttive
- 5.2** Dimensioni d'ingombro motori standard e per miniera
- 5.3** Dimensioni d'ingombro motori con freno

5. *Overall dimensions and mounting arrangements*

- 5.1** *Mounting arrangements*
- 5.2** *Overall dimensions of standard and mining version motors*
- 5.3** *Overall dimensions of motors with brakes*

5. Dimensions et formes de construction

- 5.1** Formes de construction
- 5.2** Dimensions d'encombrement des moteurs standard et pour mine
- 5.3** Dimensions d'encombrement des moteurs à frein

5. *Abmessungen und Bauformen*

- 5.1** *Bauformen*
- 5.2** *Abmessungen der Standardmotoren und der schlagwettergeschützten Motoren*
- 5.3** *Abmessungen der Motoren mit Bremse*

5. Dimensiones de espacio máximo y formas constructivas

- 5.1** Formas constructivas
- 5.2** Dimensiones totales de los motores estándares y para minas
- 5.3** Dimensiones totales de los motores con freno

ITALIANO	Forme costruttive
ENGLISH	Mounting arrangements
FRANÇAIS	Formes de construction
DEUTSCH	5. Bauformen
ESPAÑOL	5.1 Formas de fabricación

Le forme costruttive comunemente utilizzate sono raffigurate nella tabella 5A. Su richiesta sono fornite altre forme costruttive.

I motori ordinati nelle forme costruttive IM B3, IM B5 o IM B14 possono essere utilizzati anche per altre posizioni di montaggio:

- IM B3 in IM B6, IM B7, IM B8, IM V5 o IM V6,
- IM B5 in IM V1 o IM V3,
- IM B14 in IM V18 o IM V19.

La normativa per le macchine elettriche a sicurezza prescrive che debba essere impedita la caduta di corpi estranei all'interno del coprimentola.

A tale scopo i motori montati in verticale con albero rivolto verso il basso devono avere un tettuccio di protezione sopra il coprimentola.

The most commonly used mounting arrangements are shown in the table 5A. Other mounting arrangements are available on request.

Standard motors ordered in basic mounting arrangements (universal mounting arrangements)

IM B3, IM B5 or IM B14 can also be operated in the following different mounting positions:

- *IM B3 in IM B6, IM B7, IM B8, IM V5 or IM V6,*
- *IM B5 in IM V1 or IM V3,*
- *IM B14 in IM V18 or IM V19.*

According to the safety standard for electrical machines, foreign objects must be prevented from falling into the fan cover.

Motors for vertical arrangement with shaft end down are fitted with a protective hood over the fan cowl.

Les formes de construction communément utilisées sont représentées au tableau 5A. Sur demande, d'autres formes de construction peuvent être fournies.

Les moteurs commandés avec les formes de construction IM B3, IM B5 ou IM B14 peuvent également être utilisés dans d'autres positions de montage:

- IM B3 en IM B6, IM B7, IM B8, IM V5 ou IM V6,
- IM B5 en IM V1 ou IM V3,
- IM B14 en IM V18 ou IM V19.

La norme pour les machines électriques à sécurité indique qu'il faut empêcher les corps étrangers de tomber à l'intérieur du carter du ventilateur.

A cette fin, les moteurs installés verticalement avec l'arbre orienté vers le bas doivent être munis d'une tôle de protection placée au-dessus du protégé-ventilateur.

Die gewöhnlich verwendeten Bauformen werden in der Tabelle 5A dargestellt. Auf Wunsch können auch andere Bauformen geliefert werden.

Die mit den Bauformen IM B3, IM B5 oder IM B14 bestellten Motoren können auch für andere Montagepositionen verwendet werden:

- *IM B3 als IM B6, IM B7, IM B8, IM V5 oder IM V6,*
- *IM B5 als IM V1 oder IM V3,*
- *IM B14 als IM V18 oder IM V19.*

Die Richtlinie für die elektrischen Maschinen zur Sicherheit schreibt vor, dass das Herabfallen von Fremdkörpern in das Innere der Lüfterhaube geschützt sein muss.

Um dies zu verhindern, sind vertikale Motoren, deren Welle nach unten gerichtet ist, mit einem Schutzdach über der Lüfterhaube ausgestattet.

Las formas constructivas utilizadas corrientemente están descritas en la tabla 5A. Sobre pedido se proporcionan otras formas constructivas.

Los motores requeridos en las formas constructivas IM B3, IM B5 o IM B14 pueden ser utilizados incluso para otras posiciones de montaje:

- IM B3 in IM B6, IM B7, IM B8, IM V5 o IM V6,
- IM B5 in IM V1 o IM V3,
- IM B14 in IM V1 o IM V3,

La normativa sobre las máquinas eléctricas de seguridad prescribe que se debe impedir la caída de cuerpos extraños en el interior de la cubierta del ventilador.

Con este fin los motores instalados en vertical con el eje hacia abajo tiene que tener una tapa de protección por encima del cubre ventilador.

Table 5A

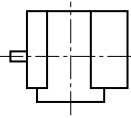
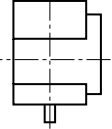
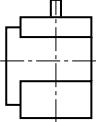
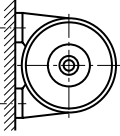
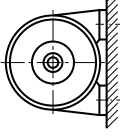
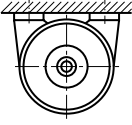
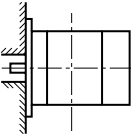
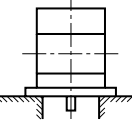
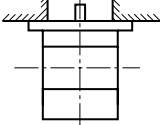
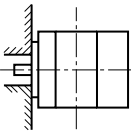
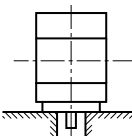
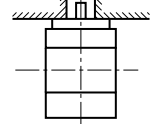
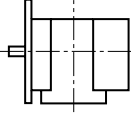
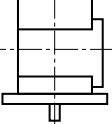
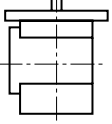
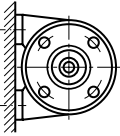
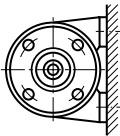
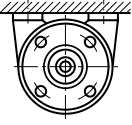
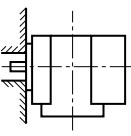
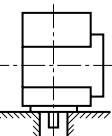
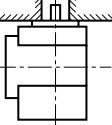
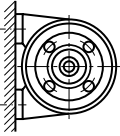
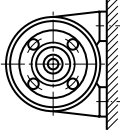
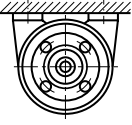
63:315	Motori con piedi <i>Foot-mounted motor</i> Moteurs à pattes Motoren mit Stützfüßen Motores con patas						
							
	CEI 2-14	B3	V5	V6	B6	B7	B8
	IEC EN 60034-7 codice I	IM B3	IM V5	IM V6	IM B6	IM B7	IM B8
IEC EN 60034-7 codice II	IM 1001	IM 1011	IM 1031	IM 1051	IM 1061	IM 1071	
63:315	Motori con flangia: flangia normale, fori di fissaggio passanti <i>Flange-mounted motor: large flange, clearance fixing holes</i> Moteurs à bride trous lisses Motoren mit Flansch: normaler Flansch, Durchgangslöcher zur Befestigung Motores con brida: brida normal, orificios de fijación de los pasadores						
							
	CEI 2-14	B5	V1	V3			
	IEC EN 60034-7 codice I	IM B5	IM V1	IM V3			
IEC EN 60034-7 codice II	IM 3001	IM 3011	IM 3031				
63:132	Motori con flangia: flangia ridotta, fori di fissaggio filettati <i>Flange-mounted motor: small flange, tapped fixing holes</i> Moteurs à bride trous taraudés Motoren mit Flansch: reduzierter Flansch, gewindegesschnittene Befestigungslöcher Motores con brida: brida reducida, orificios de fijación fileteados						
							
	CEI 2-14	B14	V18	V19			
	IEC EN 60034-7 codice I	IM B14	IM V18	IM V19			
IEC EN 60034-7 codice II	IM 3601	IM 3611	IM 3631				
63:315	Motori con piedi e flangia: flangia normale, fori di fissaggio passanti <i>Foot and flange-mounted motor: large flange, clearance fixing holes</i> Moteurs à pattes et bride trous lisses Motoren mit Stützfüßen und Flansch: normaler Flansch, Durchgangslöcher zur Befestigung Motores con patas y brida: brida normal, orificios de fijación de los pasadores						
							
	CEI 2-14	B3/B5	V5/V1	V6/V3	B6/B5	B7/B5	B8/B5
	IEC EN 60034-7 codice I	IM B35	IM V15	IM V36	IM 2051	IM 2061	IM 2071
IEC EN 60034-7 codice II	IM 2001	IM 2011	IM 2031				
63:132	Motori con piedi e flangia: flangia ridotta, fori di fissaggio filettati <i>Foot and flange-mounted motor: with small flange, tapped fixing holes</i> Moteurs à pattes et bride trous taraudés Motoren mit Stützfüßen und Flansch: reduzierter Flansch, gewindegesschnittene Befestigungslöcher Motores con patas y brida: brida reducida, orificios de fijación fileteados						
							
	CEI 2-14	B3/B14	V5/V18	V6/V19	B6/B14	B7/B14	B8/B14
	IEC EN 60034-7 codice I	IM B34	IM 2111	IM 2131	IM 2151	IM 2161	IM 2171
IEC EN 60034-7 codice II	IM 2101						

IM B3

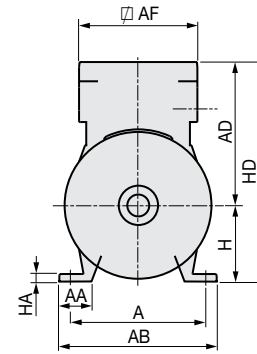
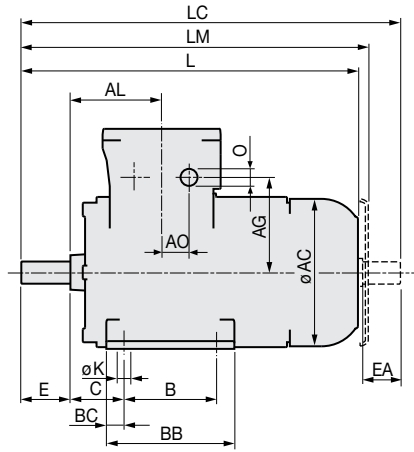

IM B5

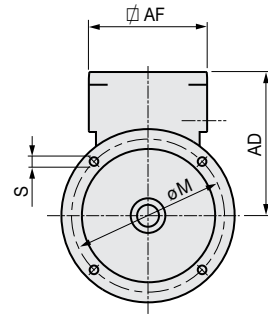
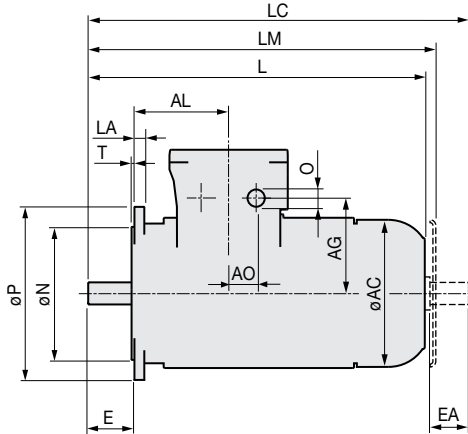

IM B35

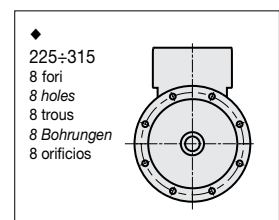
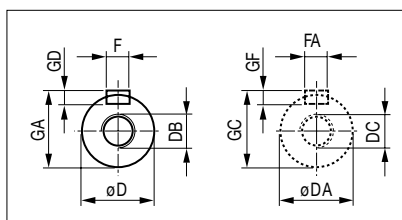
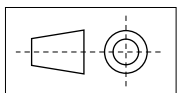
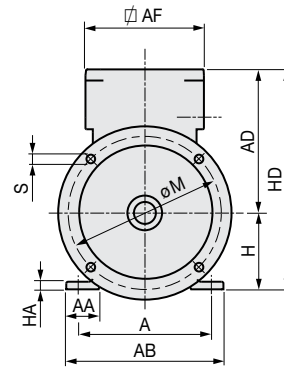
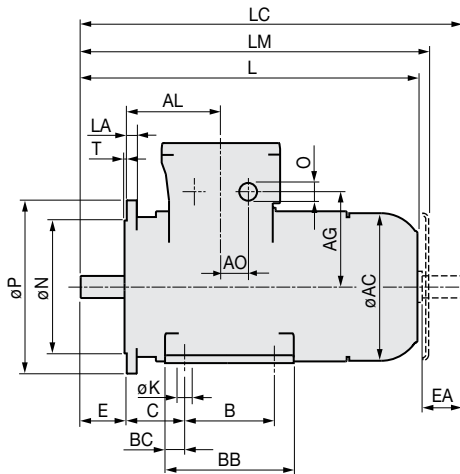

Type	A	AA	AB	ø AC	AD	□ AF	AL	B	BC	BB	C	H _{0.5} ⁰	HA	HD	ø K	$\frac{D}{L}$	LC
63	100	25	125	123	145	139	95	80	9.5	105	40	63	6	208	7	247	275.5
71	112	32	140	140	155	139	106	90	11.0	112	45	71	7	226	7	276	311.0
80	125	40	160	158	165	139	142	100	15.0	130	50	80	8	245	9	327	372.5
90 S	140	45	175	178	175	139	125	100	14.0	157	56	90	9	265	9	390	441.0
90 L	140	45	175	178	175	139	125	125	14.0	157	56	90	9	265	9	390	441.0
100	160	45	200	196	185	139	125	140	15.0	170	63	100	10	285	12	430	490.5
112	190	45	235	223	206	139	138	140	17.0	175	70	112	12	318	12	475	543.5
132 S	216	56	272	258	260	205	163	140	22.0	222	89	132	13	392	12	505	590.0
132 M-L	216	56	272	258	260	205	163	178	22.0	222	89	132	13	392	12	580	665.0
160 M	254	64	318	310	290	205	166	210	25.0	305	108	160	15	450	14	693	811.0
160 L	254	64	318	310	290	205	166	254	25.0	305	108	160	15	450	14	693	811.0
180 M	279	71	350	359	326	242	223	241	25.0	340	121	180	17	506	14	814	923.5
180 L	279	71	350	359	326	242	223	279	25.0	340	121	180	17	506	14	814	923.5
200	318	75	393	395	346	242	230	305	27.0	360	133	200	18	546	18	867	985.0
225 S	356	78	431	445	371	242	240	286	38.0	380	149	225	20	596	18	945	1090.0
225 M 2	356	78	431	445	371	242	240	311	38.0	380	149	225	20	596	18	915	1030.0
225 M 4-8	356	78	431	445	371	242	240	311	38.0	380	149	225	20	596	18	945	1090.0
250 M 2	406	95	500	467	396	242	221	349	33.0	415	168	250	22	646	24	963	1110.0
250 M 4-8	406	95	500	467	396	242	221	349	33.0	415	168	250	22	646	24	963	1110.0
280 S 2	457	90	540	558	548	320	316	368	80.0	550	190	280	41	828	25	1119	1272.0
280 S 4-8	457	90	540	558	548	320	316	368	80.0	550	190	280	41	828	25	1119	1272.0
280 M 2	457	90	540	558	548	320	316	419	80.0	550	190	280	41	828	25	1119	1272.0
280 M 4-8	457	90	540	558	548	320	316	419	80.0	550	190	280	41	828	25	1119	1272.0
315 S 2	508	110	590	558	548	320	316	406	68.5	560	216	315	41	863	27	1269	1420.0
315 S 4-8	508	110	590	558	548	320	316	406	68.5	560	216	315	41	863	27	1299	1480.0
315 M 2	508	110	590	558	548	320	316	457	68.5	560	216	315	41	863	27	1269	1420.0
315 M 4-8	508	110	590	558	548	320	316	457	68.5	560	216	315	41	863	27	1299	1480.0
315 L 2	508	100	590	626	612	320	330	457	68.5	610	216	315	41	927	28	1407	1560.0
315 L 4-8	508	100	590	626	612	320	330	457	68.5	610	216	315	41	927	28	1437	1620.0

Type	* LM	AO	IEC 60423 n. x O	AG	ø D ø DA	E EA	F FA	GA GC	GD GF	DB DC	LA	ø M	ø N	ø P	◆ S	T
63	275	24	1 x M25	100	11j6	23	4	12.5	4	M4	6.5	115	95j6	140	10	3.0
71	305	24	1 x M25	110	14j6	30	5	16.0	5	M5	6.5	130	110j6	160	10	3.5
80	356	24	1 x M25	120	19j6	40	6	21.5	6	M6	11.0	165	130j6	200	12	3.5
90 S	418	24	1 x M25	130	24j6	50	8	27.0	7	M8	12.0	165	130j6	200	12	3.5
90 L	418	24	1 x M25	130	24j6	50	8	27.0	7	M8	12.0	165	130j6	200	12	3.5
100	458	24	1 x M25	140	28j6	60	8	31.0	7	M10	14.0	215	180j6	250	15	4.0
112	503	24	1 x M25	161	28j6	60	8	31.0	7	M10	16.0	215	180j6	250	15	4.0
132 S	550	35	2 x M32	185	38k6	80	10	41.0	8	M12	17.0	265	230j6	300	15	4.0
132 M-L	625	35	2 x M32	185	38k6	80	10	41.0	8	M12	17.0	265	230j6	300	15	4.0
160 M	738	35	2 x M32	215	42k6	110	12	45.0	8	M16	18.0	300	250h6	350	18	5.0
160 L	738	35	2 x M32	215	42k6	110	12	45.0	8	M16	18.0	300	250h6	350	18	5.0
180 M	860	38	2 x M40	266	48k6	110	14	52.0	9	M16	20.0	300	250h6	350	18	5.0
180 L	860	38	2 x M40	266	48k6	110	14	52.0	9	M16	20.0	300	250h6	350	18	5.0
200	913	38	2 x M40	286	55m6	110	16	59.0	10	M20	20.0	350	300h6	400	18	5.0
225 S	991	38	2 x M40	311	60m6	140	18	64.0	11	M20	22.0	400	350h6	450	18	5.0
225 M 2	991	38	2 x M40	311	55m6	110	16	59.0	10	M20	22.0	400	350h6	450	18	5.0
225 M 4-8	991	38	2 x M40	311	60m6	140	18	64.0	11	M20	22.0	400	350h6	450	18	5.0
250 M 2	1006	38	2 x M40	336	60m6	140	18	64.0	11	M20	22.0	500	450h6	550	18	5.0
250 M 4-8	1006	38	2 x M40	336	65m6	140	18	69.0	11	M20	22.0	500	450h6	550	18	5.0
280 S 2	1215	56	2 x M63	410	65m6	140	18	69.0	11	M20	18.0	500	450h6	550	18	5.0
280 S 4-8	1215	56	2 x M63	410	75m6	140	20	79.5	12	M20	18.0	500	450h6	550	18	5.0
280 M 2	1215	56	2 x M63	410	65m6	140	18	69.0	11	M20	18.0	500	450h6	550	18	5.0
280 M 4-8	1215	56	2 x M63	410	75m6	140	20	79.5	12	M20	18.0	500	450h6	550	18	5.0
315 S 2	1365	56	2 x M63	410	65m6	140	18	69.0	11	M20	22.0	600	550h6	660	22	6.0
315 S 4-8	1395	56	2 x M63	410	80m6	170	22	85.0	14	M20	22.0	600	550h6	660	22	6.0
315 M 2	1365	56	2 x M63	410	65m6	140	18	69.0	11	M20	22.0	600	550h6	660	22	6.0
315 M 4-8	1395	56	2 x M63	410	80m6	170	22	85.0	14	M20	22.0	600	550h6	660	22	6.0
315 L 2	1503	56	2 x M63	474	65m6	140	18	69.0	11	M20	22.0	600	550h6	660	24	6.0
315 L 4-8	1533	56	2 x M63	474	80m6	170	22	85.0	14	M20	22.0	600	550h6	660	24	6.0

◆ vedi pagina 198 ; see page 198 ; voir page 198 ; siehe Seite 198 ; véase página 198 ;

▶ *  ▶ vedi pagina 201 ; see page 201 ; voir page 201 ; siehe Seite 201 ; véase página 201 ;

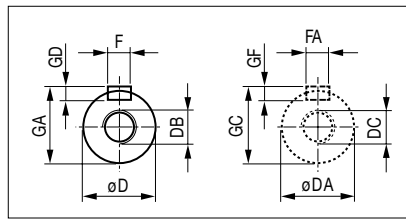
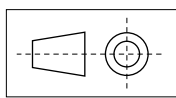
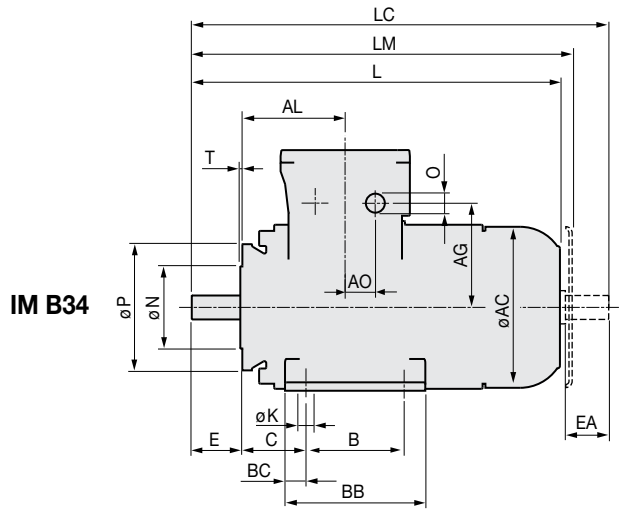
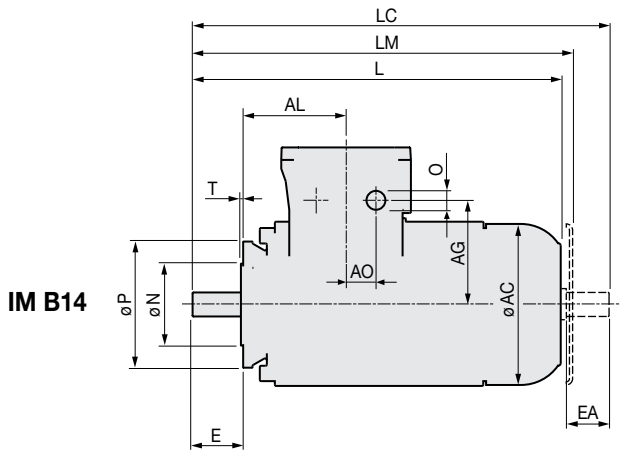

Type	A	AA	AB	∅ AC	AD	▣ AF	AL	B	BC	BB	C	H _{0.5} ⁰	HA	HD	∅ K	▾ L	LC
63	100	25	125	123	145	139	95	80	9.5	105	40	63	6	208	7	247	275.5
71	112	32	140	140	155	139	106	90	11.0	112	45	71	7	226	7	276	311.0
80	125	40	160	158	165	139	142	100	15.0	130	50	80	8	245	9	327	372.5
90 S	140	45	175	178	175	139	125	100	14.0	157	56	90	9	265	9	390	441.0
90 L	140	45	175	178	175	139	125	125	14.0	157	56	90	9	265	9	390	441.0
100	160	45	200	196	185	139	125	140	15.0	170	63	100	10	285	12	430	490.5
112	190	45	235	223	206	139	138	140	17.0	175	70	112	12	318	12	475	543.5
132 S	216	56	272	258	260	205	163	140	22.0	222	89	132	13	392	12	505	590.0
132 M-L	216	56	272	258	260	205	163	178	22.0	222	89	132	13	392	12	580	665.0
160 M	254	64	318	310	290	205	166	210	25.0	305	108	160	15	450	14	693	811.0
160 L	254	64	318	310	290	205	166	254	25.0	305	108	160	15	450	14	693	811.0

Type	* LM	AO	IEC 60423 n. x O	AG	∅ D ∅ DA	E EA	F FA	GA GC	GD GF	DB DC	∅ M	∅ N	∅ P	◆ S	T
63	275	24	1 x M25	100	11j6	23	4	12.5	4	M4	75	60j6	90	M5	2.5
71	305	24	1 x M25	110	14j6	30	5	16.0	5	M5	85	70j6	105	M6	2.5
80	356	24	1 x M25	120	19j6	40	6	21.5	6	M6	100	80j6	120	M6	3.0
90 S	418	24	1 x M25	130	24j6	50	8	27.0	7	M8	115	95j6	140	M8	3.0
90 L	418	24	1 x M25	130	24j6	50	8	27.0	7	M8	115	95j6	140	M8	3.0
100	458	24	1 x M25	140	28j6	60	8	31.0	7	M10	130	110j6	160	M8	3.5
112	503	24	1 x M25	161	28j6	60	8	31.0	7	M10	130	110j6	160	M8	3.5
132 S	550	35	2 x M32	185	38k6	80	10	41.0	8	M12	165	130j6	200	M10	3.5
132 M-L	625	35	2 x M32	185	38k6	80	10	41.0	8	M12	165	130j6	200	M10	3.5
160 M	738	35	2 x M32	215	42k6	110	12	45.0	8	M16	215	180h6	250	M12	4.0
160 L	738	35	2 x M32	215	42k6	110	12	45.0	8	M16	215	180h6	250	M12	4.0

Quote non impegnative

Tolerances allowed

Dimensions données à titre indicatif

Übliche Toleranzen

Cotas no vinculantes

▾

la quota L dei motori per miniera corrisponde alla quota LM dei motori antideflagranti per superficie

the distance L of the motors for mining applications corresponds to the distance LM of explosion-proof motors for surfaces

La dimension L des moteurs pour mine correspond à la dimension LM des moteurs antidéflagrants de surface

Der Abstand L bei schlagwettergeschützten Motoren entspricht dem Abstand LM bei explosionsgeschützten

Motoren nach Oberfläche

la cota L de los motores para minas corresponde a la cota LM de los motores antideflagrantes para superficie

*

parapioggia: normalmente presente solo per montaggio verticale, albero in basso

rain canopy: only when vertical shaft-down mounting

parapluie: uniquement pour position verticale, arbre vers le bas

Regenschutzdach: nur für die Vertikalbauformen

tapa de protección contra la lluvia: sólo para montaje en vertical, eje en la parte inferior

⊥

1 nella scatola morsetti, 1 sulla carcassa

1 in the terminal box, 1 on the frame

1 à l'intérieur de la boîte à bornes, 1 sur la carcasse

1 am Klemmkasten, 1 am Motorgehäuse

1 en la caja de bornes, 1 en la carcasa

▶

280 e 315 L piedi fissi standard, su richiesta piedi removibili con misure d'ingombro diverse da quelle indicate

280 and 315 L fixed feet. Removable feet available on request with different dimensions

280 et 315 L pieds fixes standards, sur demande pieds amovibles avec des mesures autres que celles indiquées

280 und 315 L ortsfeste Standardfüße, auf Wunsch entfernbar Füße mit von den angegebenen abweichenden Abmessungen

280 y 315 L pies fijos estándar, bajo pedido pies desmontables de medidas diferentes de las indicadas

IM B3

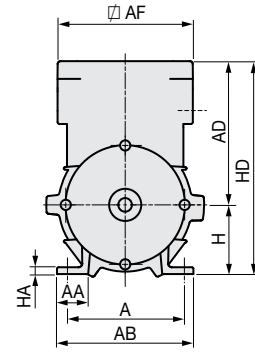
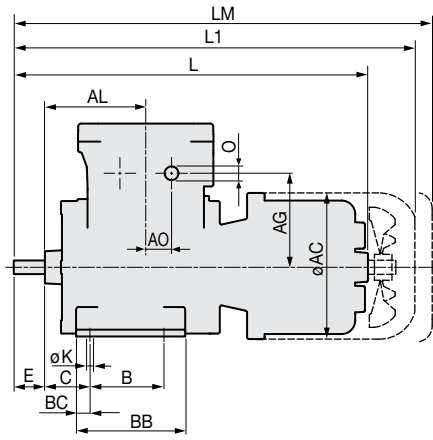

IM B5

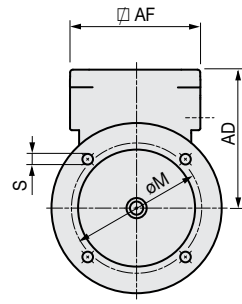
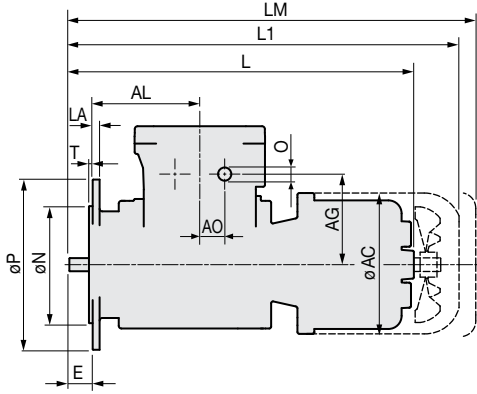

IM B35

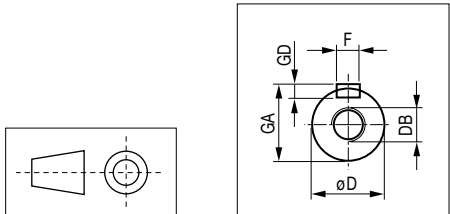
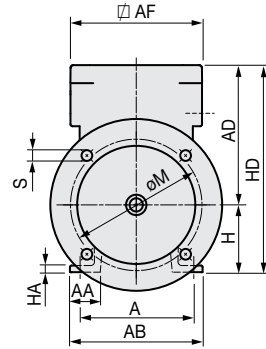
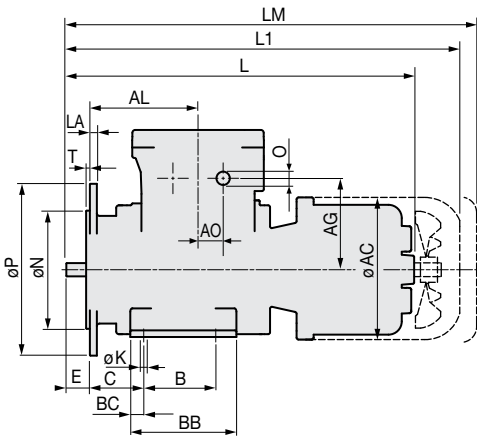

Type	A	AA	AB	ø AC	AD	AF	IM B5 AL	IM B3-B35 AL	B	BC	BB	C	H ⁰ _{-0.5}	HA	HD	ø K	● L	▼ L1
63	100	25	125	134	176	145	95	95	80	9.5	105	40	63	6	239	7	310	
71	112	32	140	165	186	145	106	106	90	11.0	112	45	71	7	257	7	365	410
80	125	40	160	183	196	145	142	142	100	15.0	130	50	80	8	276	9	423	478
90 S	140	45	175	208	206	145	125	125	100	14.0	157	56	90	9	296	9	502	557
90 L	140	45	175	208	206	145	125	125	125	14.0	157	56	90	9	296	9	502	557
100	160	45	200	234	216	145	125	125	140	15.0	170	63	100	10	316	12	537	595
112	190	45	235	259	237	145	228	138	140	17.0	175	70	112	12	349	12	609	668
132 S	216	56	272	311	260	205	193	163	140	22.0	222	89	132	13	392	12	650	722
132 M-L	216	56	272	311	260	205	268	163	178	22.0	222	89	132	13	392	12	725	797
160 M	254	64	318	348	290	205	311	166	210	25.0	305	108	160	15	450	14	823	901
160 L	254	64	318	348	290	205	311	166	254	25.0	305	108	160	15	450	14	823	901

Type	* ▼ LM	AO	IEC 60423 n. x O	AG	ø D	E	F	GA	GD	DB	LA	ø M	ø N	ø P	S	T
63		26	1xM25 1xM20	96	11j6	23	4	12.5	4	M4	6.5	115	95j6	140	10	3
71	438	26	1xM25 1xM20	106	14j6	30	5	16.0	5	M5	6.5	130	110j6	160	10	3.5
80	507	26	1xM25 1xM20	116	19j6	40	6	21.5	6	M6	11	165	130j6	200	12	3.5
90 S	585	26	1xM25 1xM20	126	24j6	50	8	27.0	7	M8	12	165	130j6	200	12	3.5
90 L	585	26	1xM25 1xM20	126	24j6	50	8	27.0	7	M8	12	165	130j6	200	12	3.5
100	624	26	1xM25 1xM20	136	28j6	60	8	31.0	7	M10	14	215	180j6	250	15	4
112	697	26	1xM25 1xM20	157	28j6	60	8	31.0	7	M10	16	215	180j6	250	15	4
132 S	767	35	2xM32 1xM20	185	38k6	80	10	41.0	8	M12	17	265	230j6	300	15	4
132 M-L	842	35	2xM32 1xM20	185	38k6	80	10	41.0	8	M12	17	265	230j6	300	15	4
160 M	946	35	2xM32 1xM20	215	42k6	110	12	45.0	8	M16	18	300	250h6	350	18	5
160 L	946	35	2xM32 1xM20	215	42k6	110	12	45.0	8	M16	18	300	250h6	350	18	5

●
Versione DB, DC
Version DB, DC
Version DB, DC
Ausführung DB, DC
Versión DB, DC

▼
Versione HB, HC
Version HB, HC
Version HB, HC
Ausführung HB, HC
Versión HB, HC

⏏
1 nella scatola morsetti, 1 sulla carcassa
1 in the terminal box, 1 on the frame
1 à l'intérieur de la boîte à bornes, 1 sur la carcasse
1 am Klemmkasten, 1 am Motorgehäuse
1 en la caja de bornes, 1 en la carcasa

Quote non impegnative
Tolerances allowed
Dimensions données à titre indicatif
Übliche Toleranzen
Cotas no vinculantes

*
parapioggia: normalmente presente solo nei motori autoventilati (IC411) per montaggio verticale, albero in basso
rain cover: normally found only on self-ventilating motors (IC411) for vertical assembly, shaft at the bottom
capot parapluie: normalement, elle n'est présente que sur les moteurs autoventilés (IC411) destinés à un montage vertical, arbre en bas
Regenschutz: ist normalerweise nur bei den eigenbelüfteten Motoren (IC411) für die senkrechte Montage, Welle unten, vorhanden
tapa de protección contra la lluvia: normalmente sólo está presente en los motores autoventilados (IC411) para el montaje en vertical, con el eje en la parte inferior

ITALIANO
 ENGLISH
 FRANÇAIS
 DEUTSCH
 ESPAÑOL

Dimensioni d'ingombro motori con freno
 Overall dimensions of motors with brakes
 Dimensions d'encombrement des moteurs à frein
 Abmessungen der Motoren mit Bremse
 Dimensiones totales de los motores con freno

DB	HB		
DC	HC		
63÷160	71÷160	IM B14	IM B34

5.
 5.3

IM B14

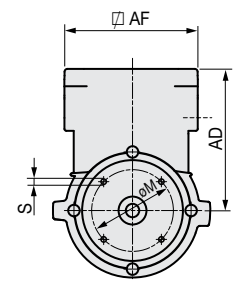
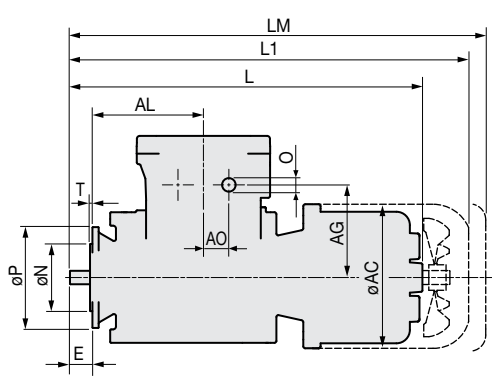

IM B34

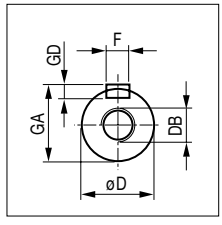
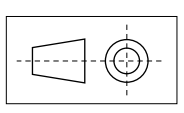
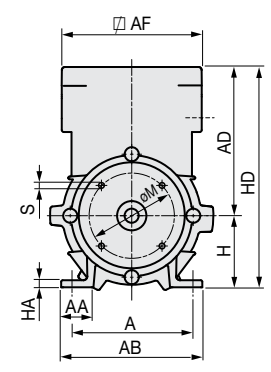
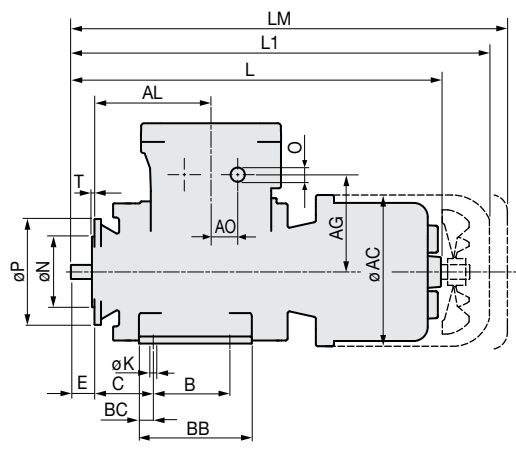

Type	A	AA	AB	∅ AC	AD	AF	IM B14 AL	IM B34 AL	B	BC	BB	C	H _{-0.5} ⁰	HA	HD	∅ K	● L	▼ L1
63	100	25	125	134	176	145	95	95	80	9.5	105	40	63	6	239	7	310	
71	112	32	140	165	186	145	106	106	90	11.0	112	45	71	7	257	7	365	410
80	125	40	160	183	196	145	142	142	100	15.0	130	50	80	8	276	9	423	478
90 S	140	45	175	208	206	145	125	125	100	14.0	157	56	90	9	296	9	502	557
90 L	140	45	175	208	206	145	125	125	125	14.0	157	56	90	9	296	9	502	557
100	160	45	200	234	216	145	125	125	140	15.0	170	63	100	10	316	12	537	595
112	190	45	235	259	237	145	228	138	140	17.0	175	70	112	12	349	12	609	668
132 S	216	56	272	311	260	205	193	163	140	22.0	222	89	132	13	392	12	650	722
132 M-L	216	56	272	311	260	205	268	163	178	22.0	222	89	132	13	392	12	725	797
160 M	254	64	318	348	290	205	311	166	210	25.0	305	108	160	15	450	14	823	901
160 L	254	64	318	348	290	205	311	166	254	25.0	305	108	160	15	450	14	823	901

Type	* ▼ LM	AO	IEC 60423 n. x O	AG	∅ D	E	F	GA	GD	DB	∅ M	∅ N	∅ P	S	T
63		26	1xM25 1xM20	96	11j6	23	4	12.5	4	M4	75	60j6	90	M5	2.5
71	438	26	1xM25 1xM20	106	14j6	30	5	16.0	5	M5	85	70j6	105	M6	2.5
80	507	26	1xM25 1xM20	116	19j6	40	6	21.5	6	M6	100	80j6	120	M6	3
90 S	585	26	1xM25 1xM20	126	24j6	50	8	27.0	7	M8	115	95j6	140	M8	3
90 L	585	26	1xM25 1xM20	126	24j6	50	8	27.0	7	M8	115	95j6	140	M8	3
100	624	26	1xM25 1xM20	136	28j6	60	8	31.0	7	M10	130	110j6	160	M8	3.5
112	697	26	1xM25 1xM20	157	28j6	60	8	31.0	7	M10	130	110j6	160	M8	3.5
132 S	767	35	2xM32 1xM20	185	38k6	80	10	41.0	8	M12	165	130j6	200	M10	3.5
132 M-L	842	35	2xM32 1xM20	185	38k6	80	10	41.0	8	M12	165	130j6	200	M10	3.5
160 M	946	35	2xM32 1xM20	215	42k6	110	12	45.0	8	M16	215	180h6	250	M12	4
160 L	946	35	2xM32 1xM20	215	42k6	110	12	45.0	8	M16	215	180h6	250	M12	4

●
Versione DB, DC
Version DB, DC
Version DB, DC
Ausführung DB, DC
Versión DB, DC

▼
Versione HB, HC
Version HB, HC
Version HB, HC
Ausführung HB, HC
Versión HB, HC

⏏
1 nella scatola morsetti, 1 sulla carcassa
1 in the terminal box, 1 on the frame
1 à l'intérieur de la boîte à bornes, 1 sur la carcasse
1 am Klemmkasten, 1 am Motorgehäuse
1 en la caja de bornes, 1 en la carcasa

Quote non impegnative
Tolerances allowed
Dimensions données à titre indicatif
Übliche Toleranzen
Cotas no vinculantes

*
parapioggia: normalmente presente solo nei motori autoventilati (IC411) per montaggio verticale, albero in basso
rain cover: normally found only on self-ventilating motors (IC411) for vertical assembly, shaft at the bottom
capot parapluie: normalement, elle n'est présente que sur les moteurs autoventilés (IC411) destinés à un montage vertical, arbre en bas
Regenschutz: ist normalerweise nur bei den eigenbelüfteten Motoren (IC411) für die senkrechte Montage, Welle unten, vorhanden
tapa de protección contra la lluvia: normalmente sólo está presente en los motores autoventilados (IC411) para el montaje en vertical, con el eje en la parte inferior

5.
5.3

IM B3

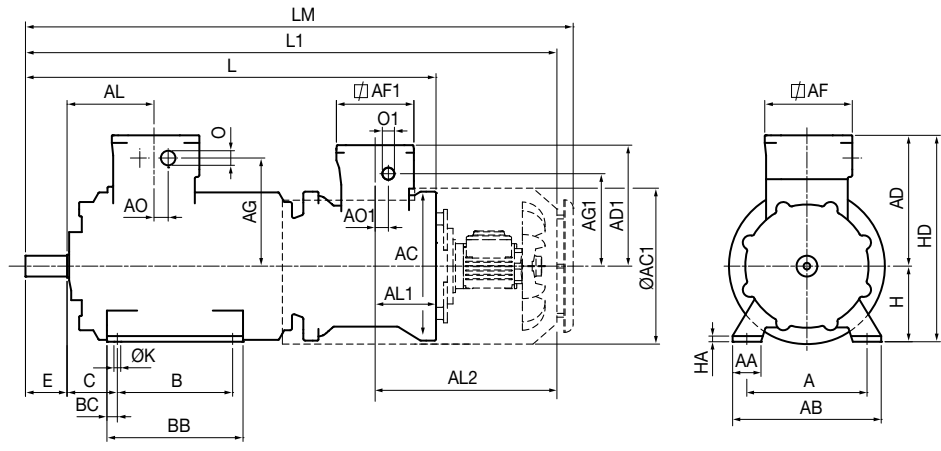

IM B5

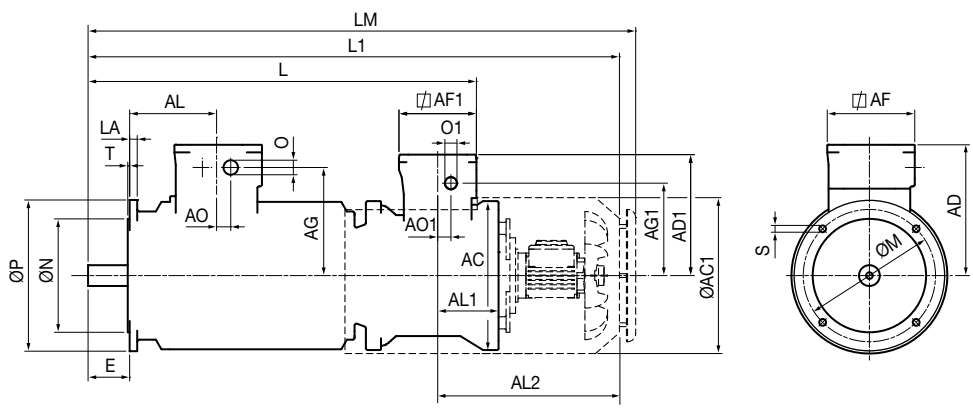

IM B35

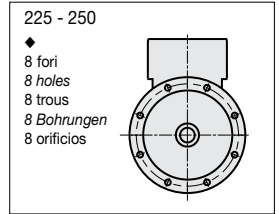
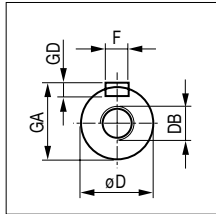
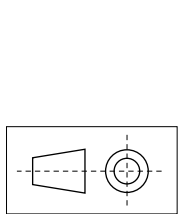
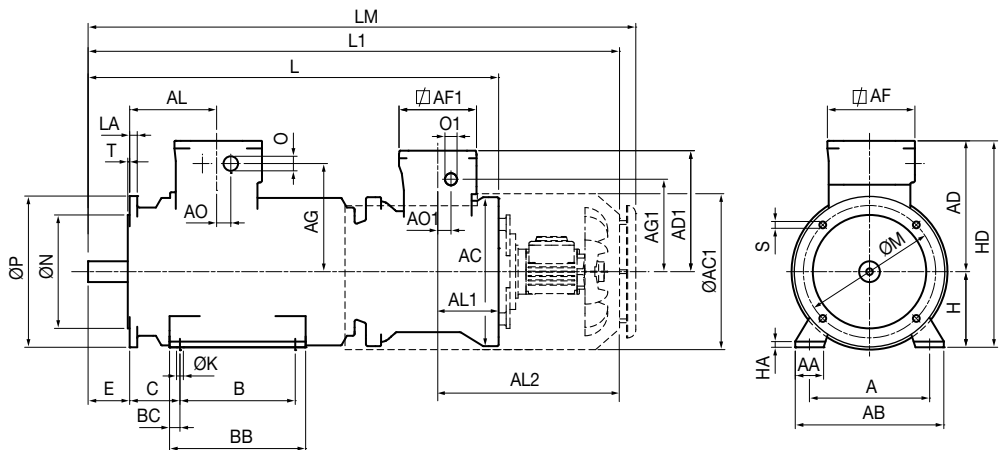

Type	A	AA	AB	∅ AC	AC1	AD	AD1	∅ AF	∅ AF1	AL	AL1	AL2	B	BC	BB	C	H _{-0.5} ⁰	HA	HD	∅ K	L
180 M	279	71	350	394	412	326	320	242	205	223	162	482	241	25.0	340	121	180	17	506	14	1055
180 L	279	71	350	394	412	326	320	242	205	223	162	482	279	25.0	340	121	180	17	506	14	1055
200	318	75	393	394	412	346	320	242	205	230	162	481	305	27.0	360	133	200	18	546	18	1086
225 S	356	78	431	394	467	371	320	242	205	240	162	506	286	38.0	380	149	225	20	596	18	1156
225 M 4-8	356	78	431	394	467	371	320	242	205	240	162	506	311	38.0	380	149	225	20	596	18	1156
250 M 4-8	406	95	500	394	467	396	320	242	205	221	162	507	349	33.0	415	168	250	22	646	24	1157
280 S 4-8	457	90	540	394	558	548	320	320	205	316	162	618	368	80.0	550	190	280	41	828	25	1265
280 M 4-8	457	90	540	394	558	548	320	320	205	316	162	618	419	80.0	550	190	280	41	828	25	1265
315 S 4-8	508	110	590	394	558	548	320	320	205	316	162	618	406	68.5	560	216	315	41	863	27	1445
315 M 4-8	508	110	590	394	558	548	320	320	205	316	162	618	457	68.5	560	216	315	41	863	27	1445

Type	L1	LM	AO	AO1	IEC 60423 n. x O	IEC 60423 n. x O1	AG	AG1	∅ D	E	F	GA	GD	DB	LA	∅ M	∅ N	∅ P	S	T
180 M	1376	1419	38	35	2xM40	1xM25	266	245	48k6	110	14	52.0	9	M16	20	300	250h6	350	18	5
180 L	1376	1419	38	35	2xM40	1xM25	266	245	48k6	110	14	52.0	9	M16	20	300	250h6	350	18	5
200	1412	1455	38	35	2xM40	1xM25	286	245	55m6	110	16	59.0	10	M20	20	350	300h6	400	18	5
225 S	1501	1544	38	35	2xM40	1xM25	311	245	60m6	140	18	64.0	11	M20	22	400	350h6	450	18	5
225 M 4-8	1501	1544	38	35	2xM40	1xM25	311	245	60m6	140	18	64.0	11	M20	22	400	350h6	450	18	5
250 M 4-8	1503	1546	38	35	2xM40	1xM25	336	245	65m6	140	18	69.0	11	M20	22	500	450h6	550	18	5
280 S 4-8	1721	1817	56	35	2xM63	1xM25	410	245	75m6	140	20	79.5	9	M20	18	500	450h6	550	18	5
280 M 4-8	1721	1817	56	35	2xM63	1xM25	410	245	75m6	140	20	79.5	9	M20	18	500	450h6	550	18	5
315 S 4-8	1901	1997	56	35	2xM63	1xM25	410	245	80m6	170	22	85.0	9	M20	22	600	550h6	660	22	6
315 M 4-8	1901	1997	56	35	2xM63	1xM25	410	245	80m6	170	22	85.0	9	M20	22	600	550h6	660	22	6



1 nella scatola morsetti del motore, 1 sulla carcassa e 1 nella scatola morsetti del freno
 1 in the motor terminal box, 1 on the motor frame and 1 in the brake terminal box
 1 dans la boîte à bornes du moteur, 1 sur la carcasse et 1 dans la boîte à bornes du frein
 1 im Klemmenkasten des Motors, 1 auf dem Gehäuse und 1 im Klemmenkasten der Bremse
 1 en la caja de bornes del motor, 1 en la carcasa y 1 en la caja de bornes del freno

Quote non impegnative
 Tolerances allowed
 Dimensions données à titre indicatif
 Übliche Toleranzen
 Cotas no vinculantes

6. Parti di ricambio

6. *Spare parts*

6. Pièces détachées

6. *Ersatzteilliste*

6. Piezas de repuesto

Parti di ricambio

Spare parts

Pièces detachées

Ersatzteilliste

6. Piezas de repuesto

1 Fondello esterno anteriore	(13) Anello ritenzione grasso posteriore	25 Cuscinetto posteriore	44 Supporto motore ventilazione assistita
(2) Ingrassatore anteriore	(14) Ingrassatore posteriore	26 Anello di tenuta posteriore	45 Motore ventilazione assistita
3 Cuscinetto anteriore	15 Fondello esterno posteriore	27 Ventola	52 Targa
4 Scatola morsetti	16 Calotta copriventola	(28) Tettuccio parapigioggia	53 Vite di messa a terra
(5) Nipplo passaggio ausiliari	17 Albero	29 Scudo posteriore portafreno	54 Basetta di separazione
6 Coperchio scatola morsetti	18 Anello di tenuta anteriore	30 Custodia freno	55 Freno
7 Morsettieria	(19) Anello ritenzione grasso anteriore	38 Scudo custodia freno	(...) = quando previsto
8 Nipplo passaggio cavi	20 Scudo anteriore	39 Custodia coprifreno	N.B.: la calotta copriventola (16) nei motori per miniera è saldata al tettuccio parapigioggia (28)
9 Rotore	21 Molle di precarico	40 Coperchio scatola morsetti freno	
10 Statore avvolto	22 Fondello interno anteriore	41 Scatola morsetti freno	
11 Carcassa	(23) Piedi	42 Morsettieria freno	
12 Scudo posteriore	24 Fondello interno posteriore	43 Nipplo passaggio cavi freno	

1 End cap - front	(13) Grease sealing ring - rear	25 Rear bearing	44 Forced ventilation motor support
(2) Grease nipple - front	(14) Grease nipple - rear	26 Sealing ring - rear	45 Forced ventilation motor
3 Front bearing	15 End cap - rear	27 Cooling fan	52 Plate
4 Terminal box	16 Fan cover (cowl)	(28) Rain cap	53 Electrical earth screw
(5) Auxiliary connections	17 Shaft	29 NDE shield brake holder	54 Separation base
6 Terminal box lid	18 Sealing ring - front	30 Brake enclosure	55 Brake
7 Terminal board	(19) Grease sealing ring - front	38 Brake shield	(...) = when provided
8 Cable nipple	20 Endshield - front	39 Brake cover enclosure	N.B.: the fan cap (16) in the motors for mining applications is welded to the rain cover (28)
9 Rotor	21 Pre loading springs	40 Brake terminal box cover	
10 Wound stator	22 Inner bearing cap - front	41 Brake terminal box	
11 Frame	(23) Feet	42 Brake terminal board	
12 Endshield - rear	24 Inner bearing cap - rear	43 Cable nipple brake	

1 Couvercle avant	(13) Bague arrière de rétention graisse	25 Roulement arrière	44 Support du moteur avec ventilation assistée
(2) Graisseur avant	(14) Graisseur arrière	26 Bague arrière d'étanchéité	45 Moteur avec ventilation assistée
3 Roulement avant	15 Couvercle arrière	27 Ventilateur	52 Plaque
4 Boîte à bornes	16 Capot de ventilateur	(28) Tôle parapluie	53 Vis de mise à la terre
(5) Dispositif pour le passage des auxiliaires	17 Arbre	29 Flasque porte-frein	54 Base de séparation
6 Couvercle boîte à bornes	18 Bague avant d'étanchéité	30 Carter du frein	55 Frein
7 Bornes traversante	(19) Bague avant de rétention graisse	38 Couvercle du frein	(...) = si prévu
8 Dispositif pour le passage des câbles	20 Flasque avant	39 Carter de protection du frein	N.B.: le capot du ventilateur (16) dans les moteurs pour mine est soudé au capot parapluie (28)
9 Rotor	21 Ressorts de précharge	40 Couvercle de la boîte à bornes du frein	
10 Stator enveloppé	22 Flasque intérieur avant	41 Boîte à bornes du frein	
11 Carcasse	(23) Pattes	42 Bornier du frein	
12 Flasque arrière	24 Flasque intérieur arrière	43 Dispositif pour le passage des câble du frein	

1 Äusserer Fettkammerdeckel A-Seite	(13) Schmierfett - Schleuderring B-Seite	25 Kugellager B-Seite	44 Träger Motor Fremdbelüftung
(2) Schmiernippel A-Seite	(14) Schmiernippel B-Seite	26 Dichtungsring B-Seite	45 Motor Fremdbelüftung
3 Kugellager A-Seite	15 Äusserer Fettkammerdeckel B-Seite	27 Lüfterflügel	52 Typenschild
4 Klemmkasten	16 Lüfterhaube	(28) Regenschutzdach	53 Erdungsschrauben
(5) Kabeldurchführung Hilfskreise	17 Welle	29 Lagerschild B-Seite Bremsenhalter	54 Trennplatte
6 Klemmkastendeckel	18 Dichtungsring A-Seite	30 Kapselung der Bremse	55 Bremse
7 Klemmbrett	(19) Schmierfett Schleuderring A-Seite	38 Deckel Bremse	(...) = wenn vorgesehen
8 Druckfeste Kabeldurchführung	20 Lagerschild A-Seite	39 Kapselung Bremsabdeckung	ZUR BEACHTUNG: Bei den schlagwettergeschützten Motoren ist die Lüfterhaube (16) mit dem Regenschutzdach (28) verschweisst
9 Läufer	21 Lagervorspannung	40 Deckel Bremsen-Klemmenkasten	
10 Gewickelter Stator	22 Innerer Fettkammerdeckel A-Seite	41 Bremsen-Klemmenkasten	
11 Motorgehäuse	(23) Füße	42 Bremsen-Anschlussklemmen	
12 Lagerschild B-Seite	24 Innerer Fettkammerdeckel B-Seite	43 Druckfeste Kabeldurchführung der Bremse	

1 Tapa externa delantera	(13) Anillo retención grasa trasero	25 Cojinete trasero	44 Soporte motor ventilación asistida
(2) Engrasador delantero	(14) Engrasador trasero	26 Anillo de retención trasero	45 Motor ventilación asistida
3 Cojinete delantero	15 Fondo externo trasero	27 Ventilador	52 Placa
4 Caja de bornes	16 Casquete cubre ventilador	(28) Tapa de protección contra la lluvia	53 Tornillo e toma a tierra
(5) Niple paso auxiliares	17 Eje	29 Escudo portafrenos	54 Base de separación
6 Tapa de la caja de bornes	18 Anillo de retención delantero	30 Envolvente del freno	55 Freno
7 Placa de bornes	(19) Anillo retención grasa delantero	38 Tapa del freno	(...) = cuando previsto
8 Niple paso cables	20 Escudo delantero	39 Protector del freno	Nota importantes: el cárter del ventilador (16) en los motores para minas está soldado al techo para proteger de la lluvia (28)
9 Rotor	21 Muelles de carga previa	40 Tapa caja de bornes freno	
10 Estátor bobinado	22 Fondo interno delantero	41 Caja de bornes freno	
11 Armazón	(23) Pies	42 Placa de bornes freno	
12 Escudo trasero	24 Tapa interna trasera	43 Niple paso cables del freno	

63÷132

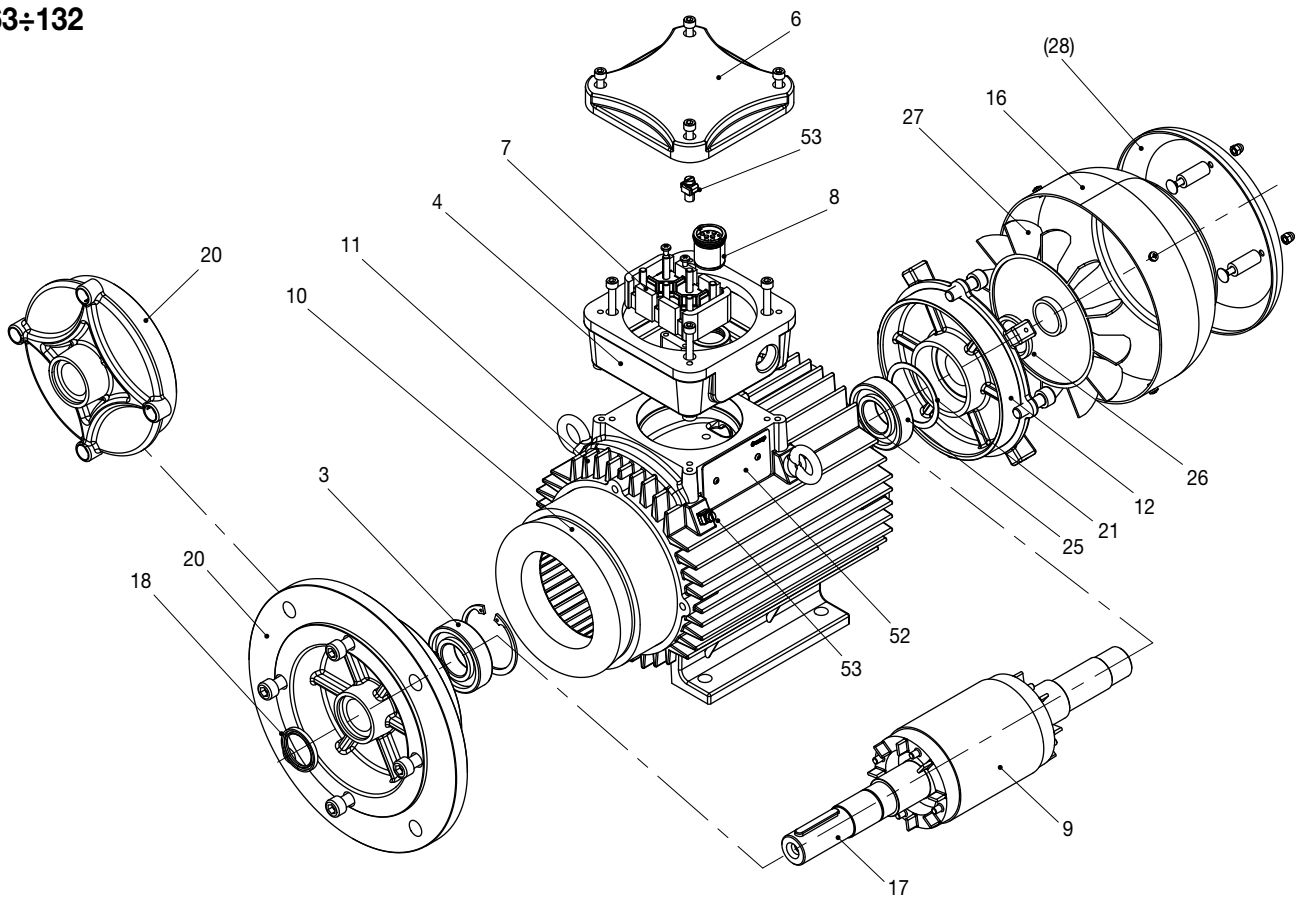

160

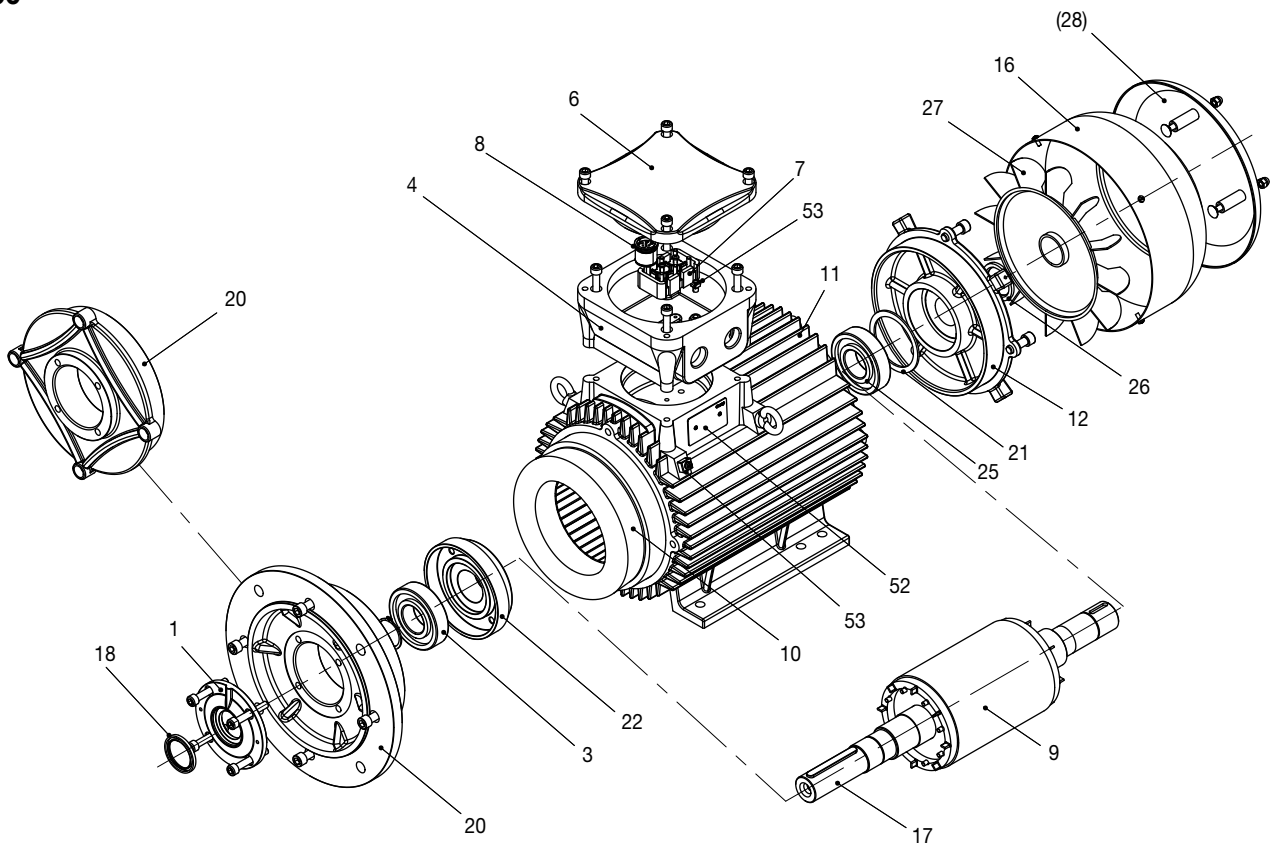

63÷132

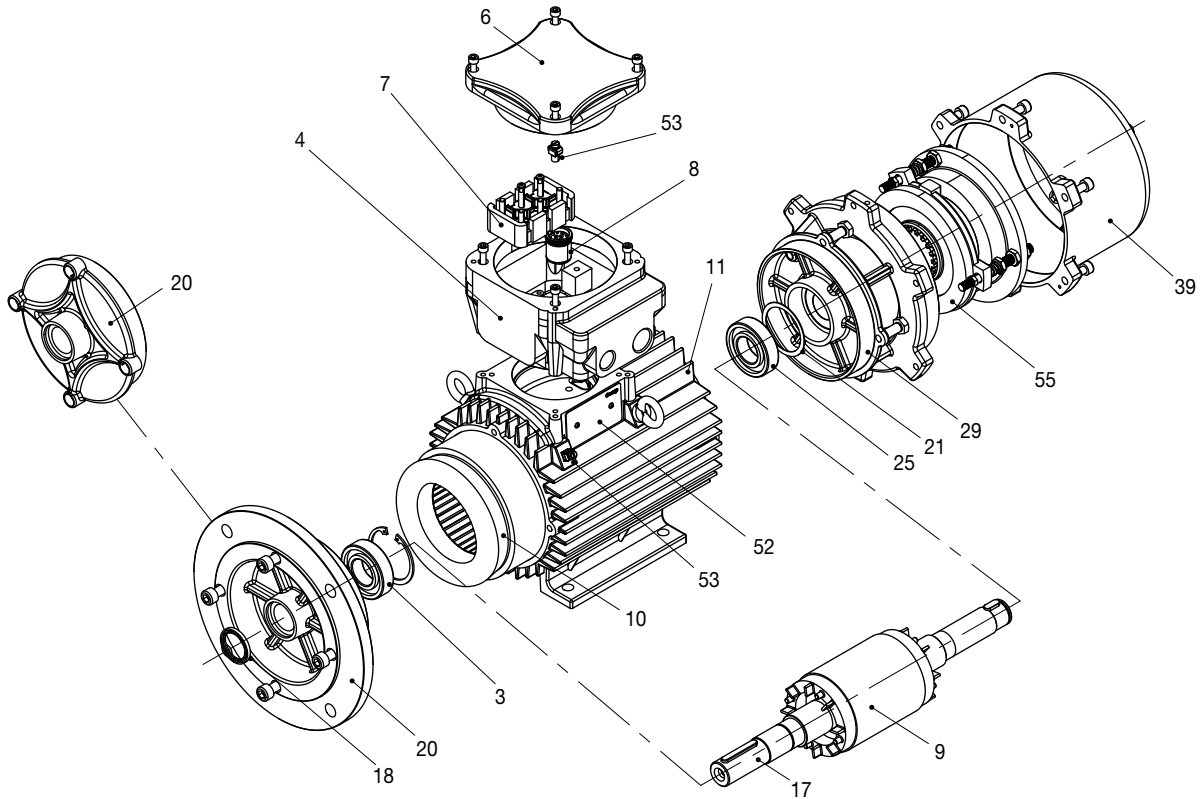

160

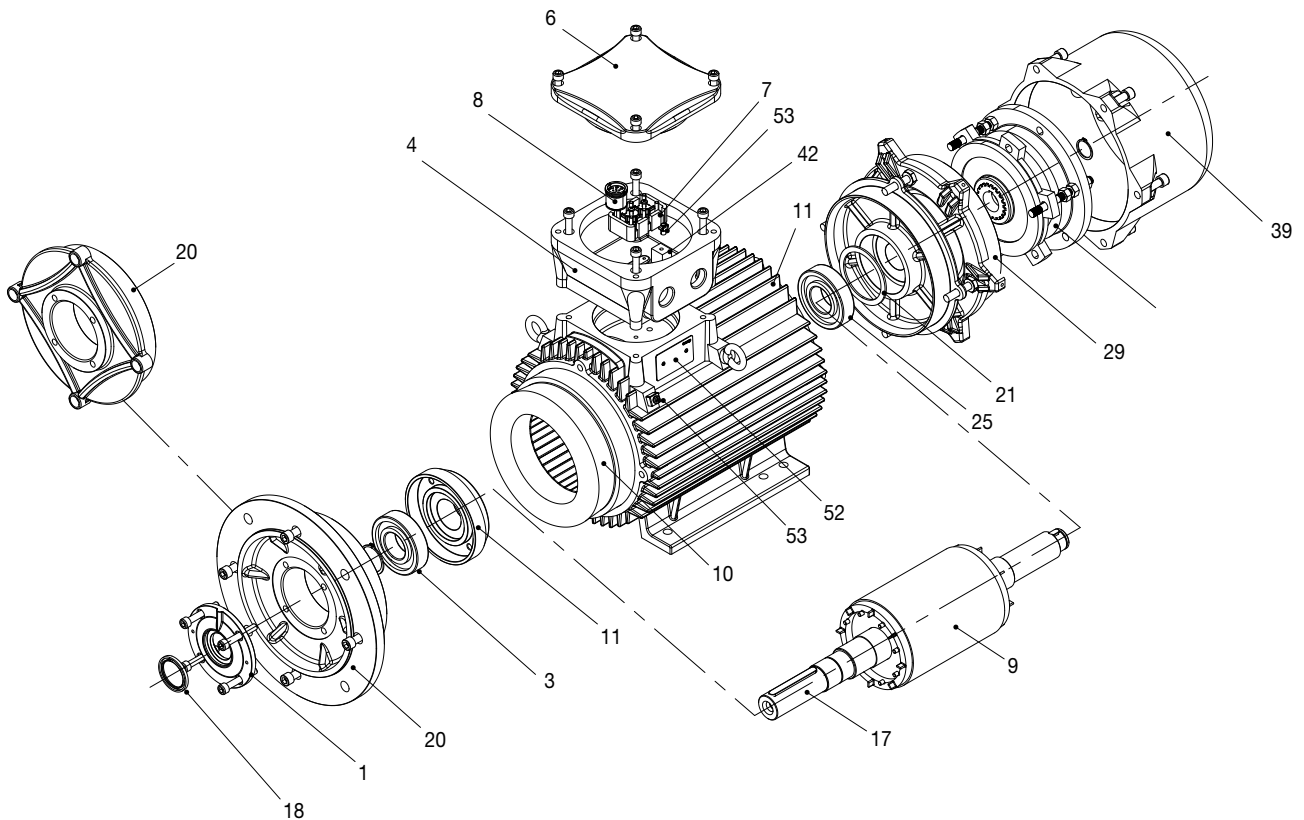

180÷250

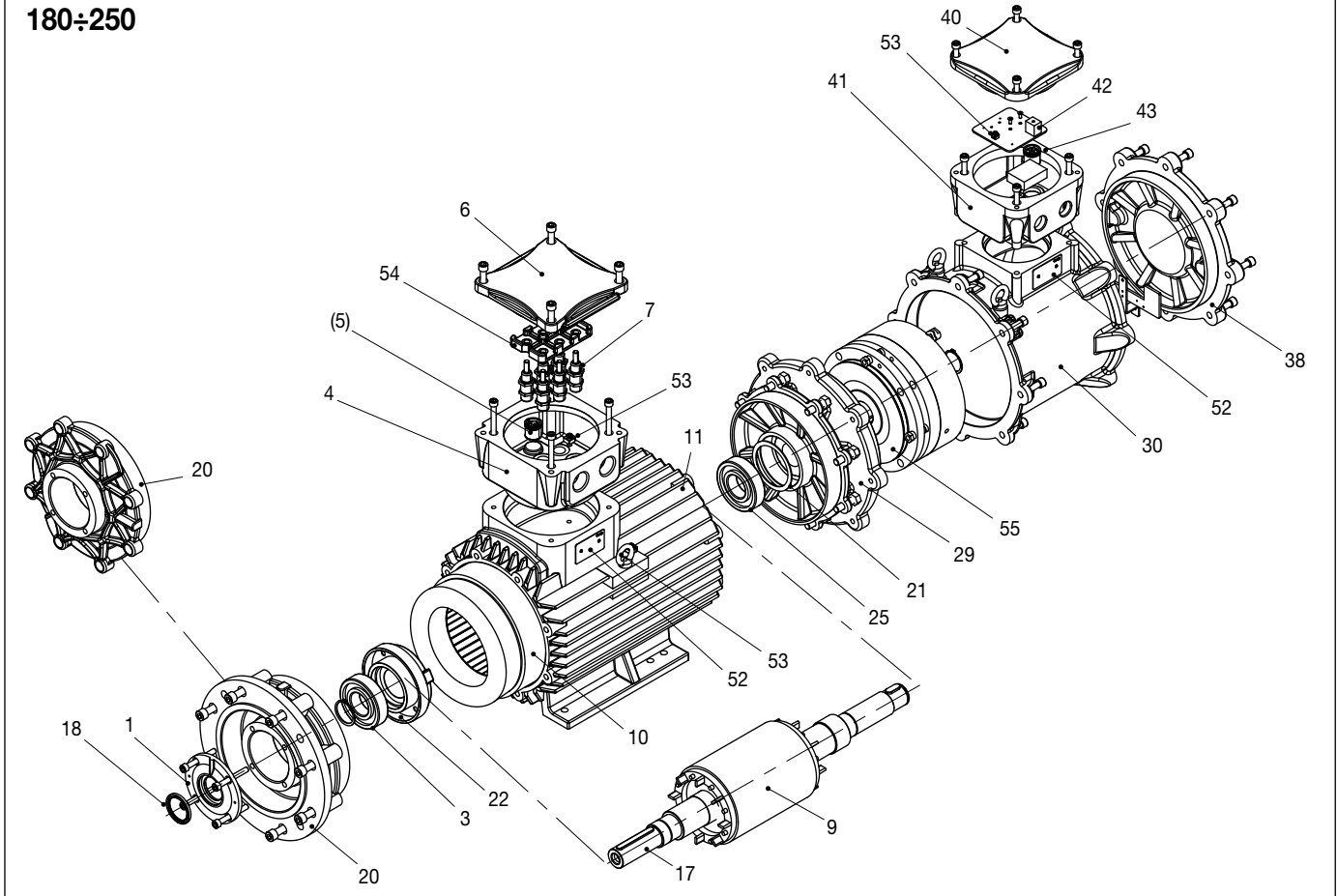

280÷315

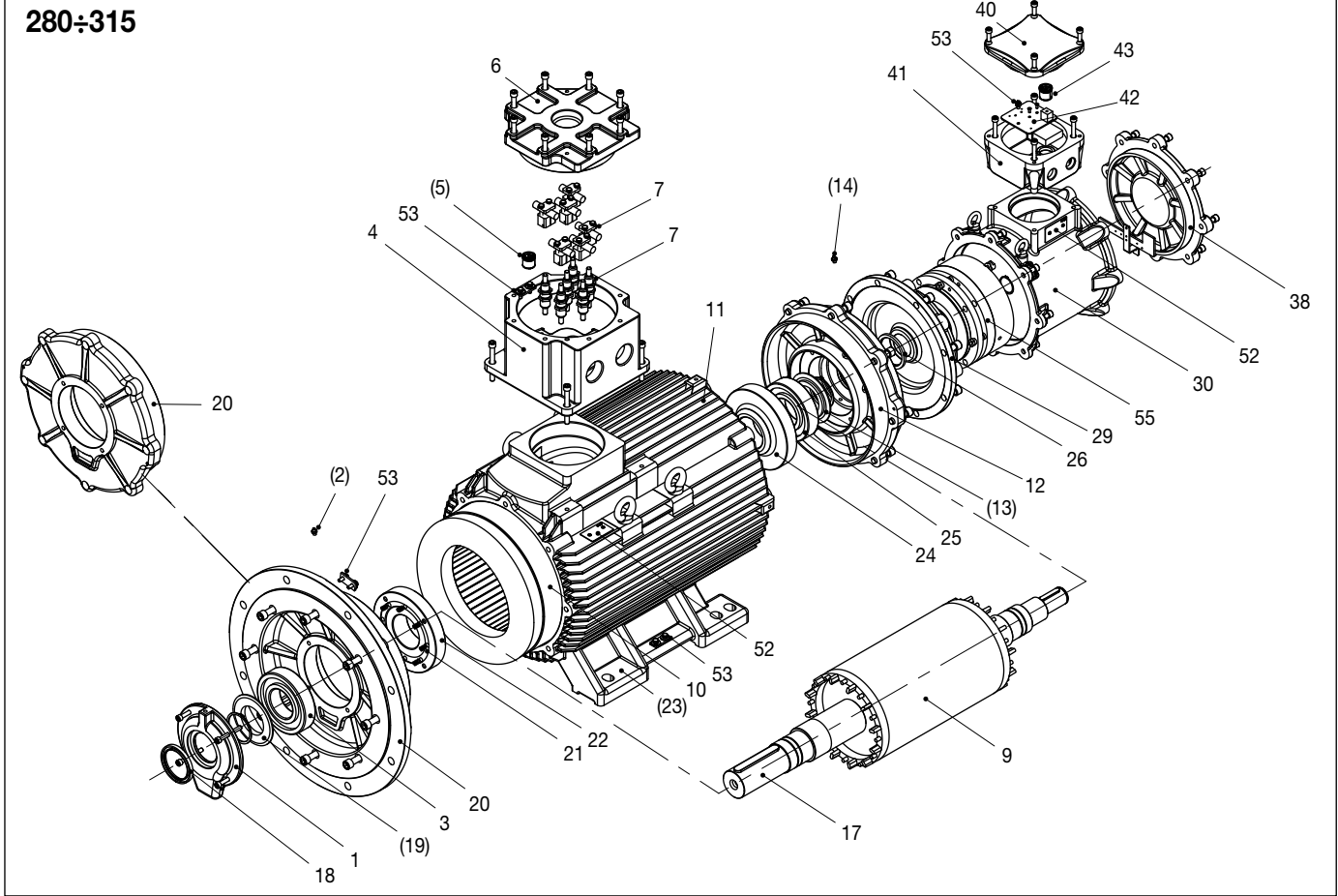

180÷250

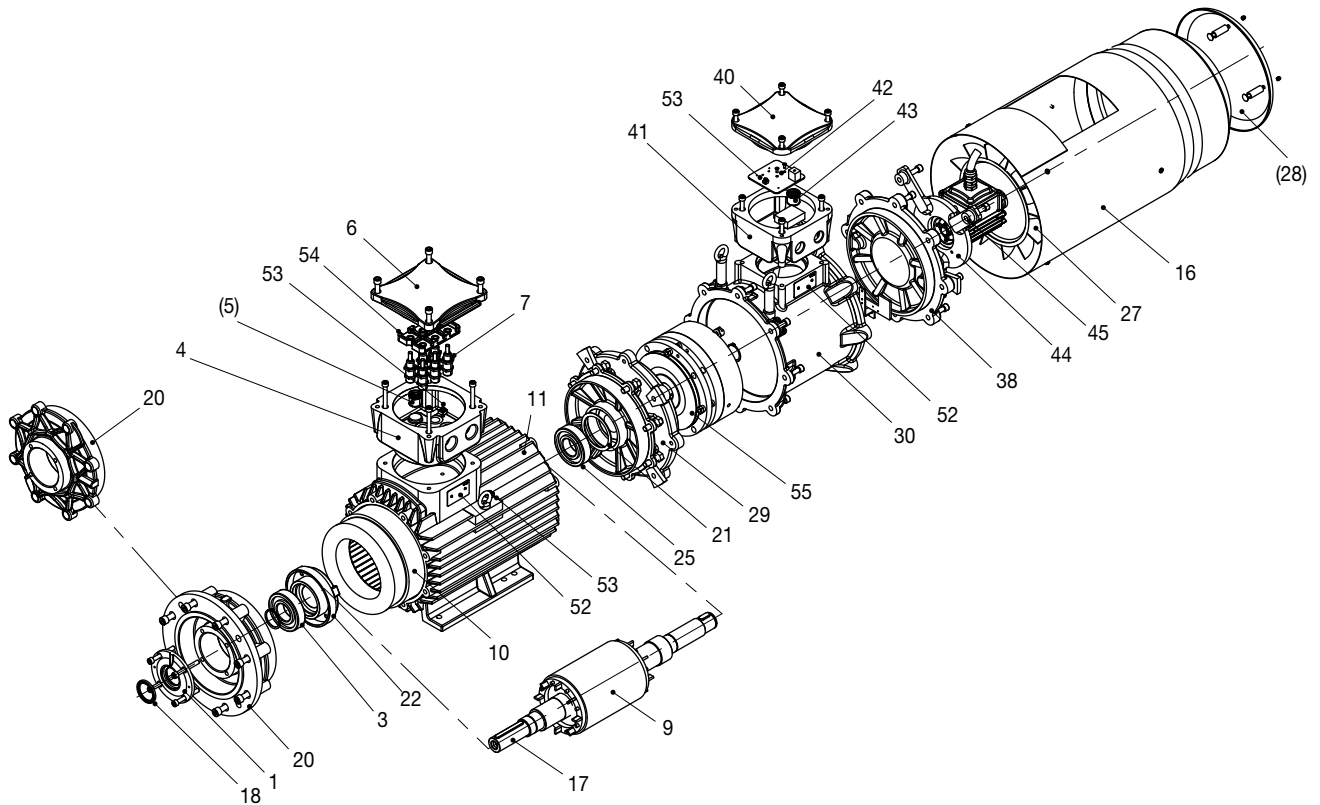

280÷315

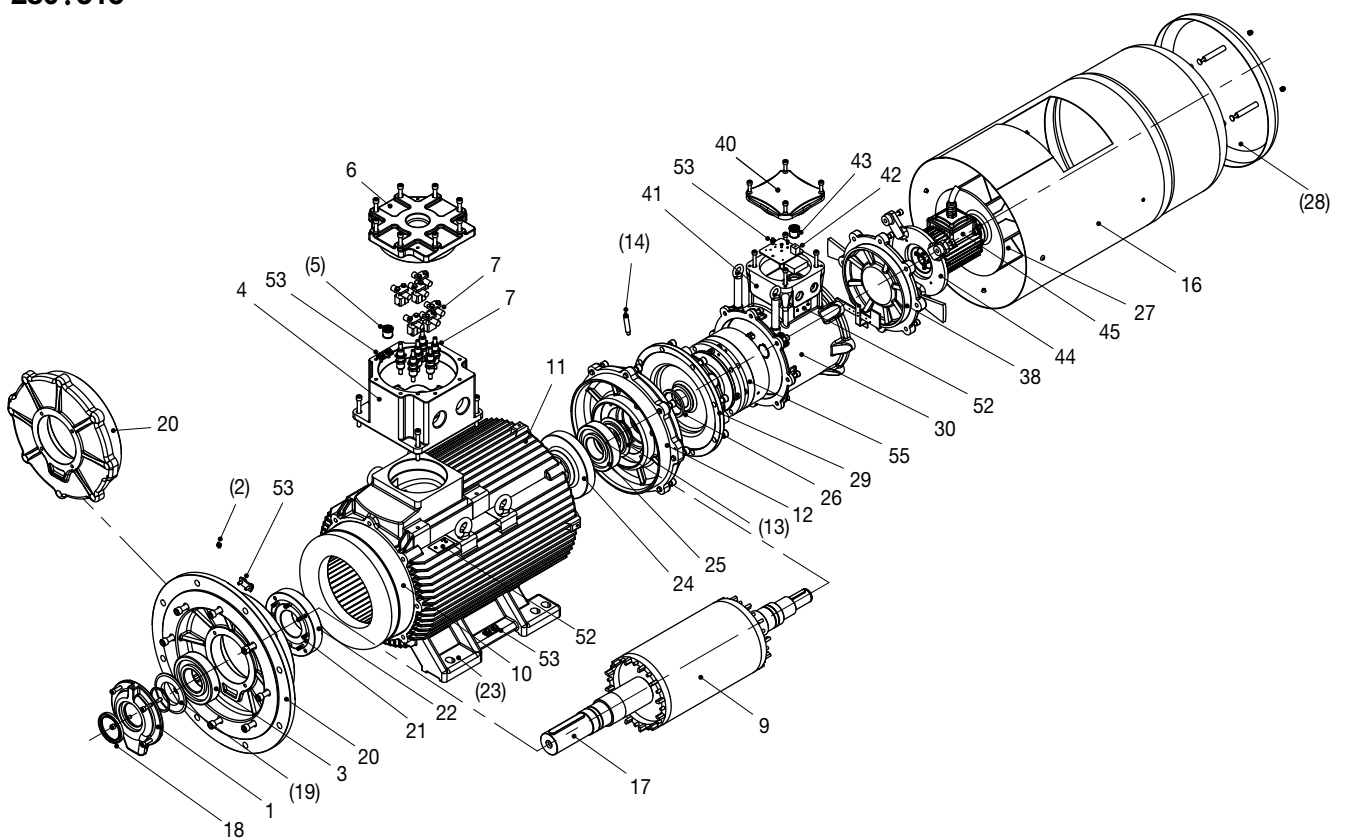

71÷132

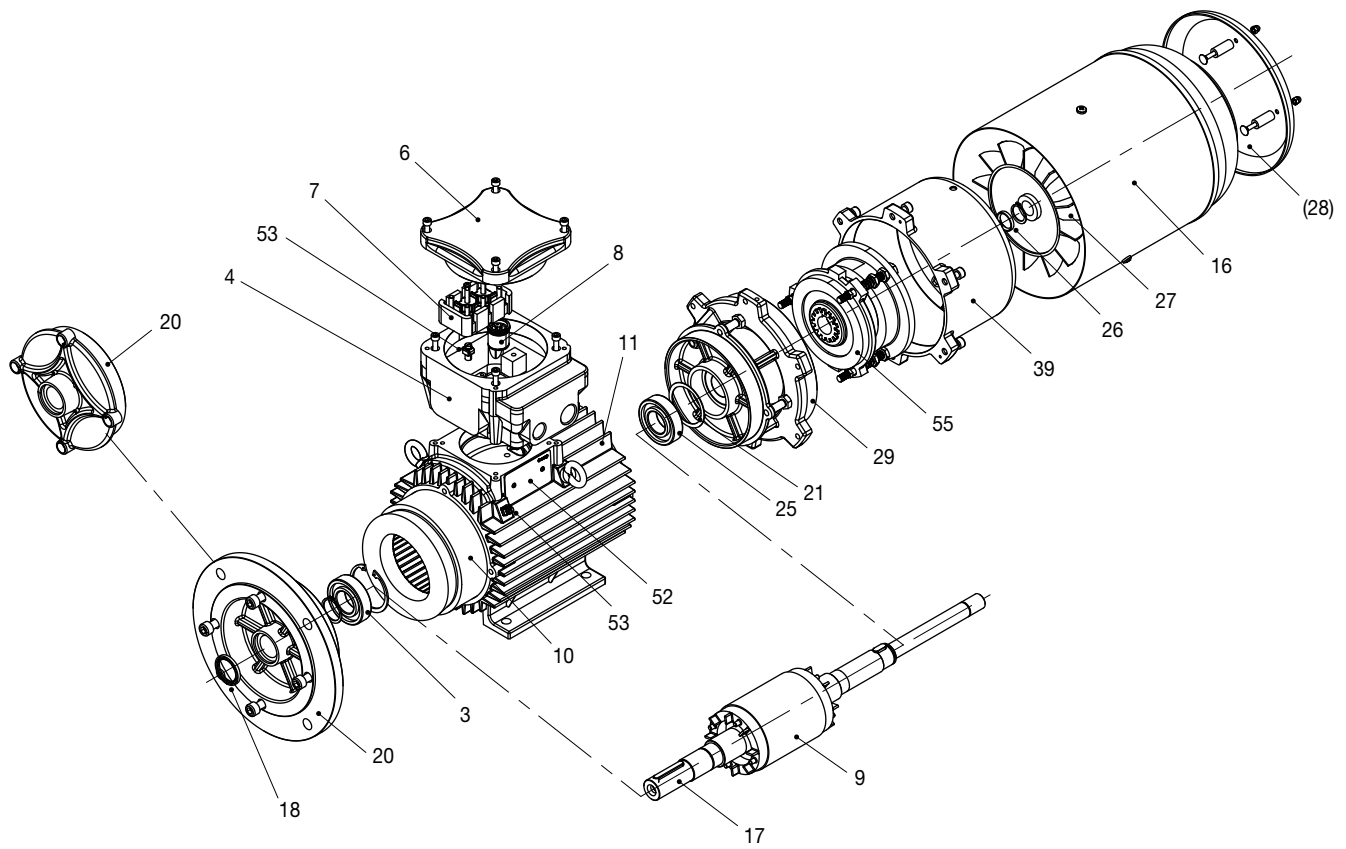

160

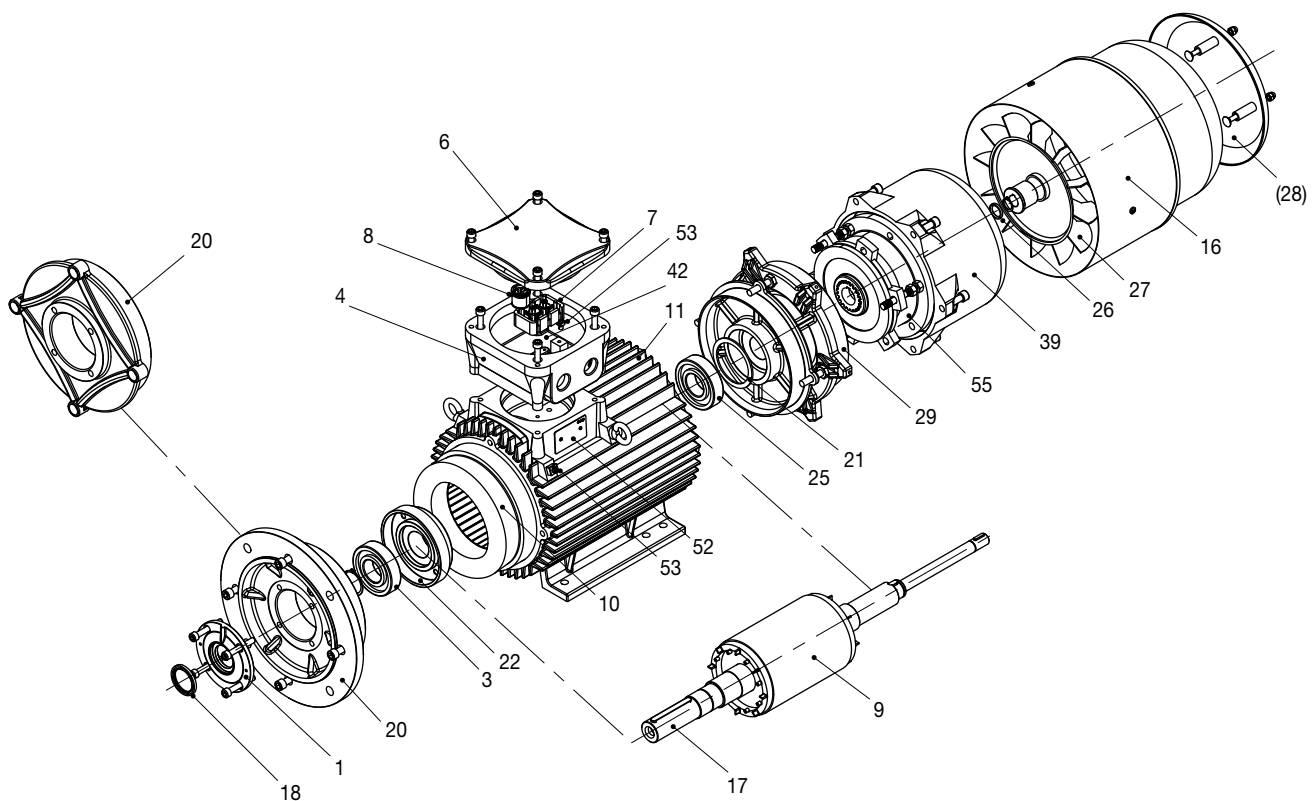

Nel redigere questa documentazione è stata posta ogni cura al fine di assicurare la correttezza delle informazioni contenute.

Every care has been taken to ensure the accuracy of the information contained in this publication.

Dans la préparation de cette documentation nous avons pris le soin d'y intégrer les informations les plus exactes possibles.

Die Ausführungen und technischen Eigenschaften, die in dieser Broschüre angegeben sind, dürfen nicht als verbindlich angesehen werden.

La presente documentación se ha redactado de manera muy atenta para poder asegurar que las informaciones que contiene son correctas.

Tuttavia, anche in conseguenza della politica di continuo sviluppo e miglioramento della qualità del prodotto perseguita da Cemp, la società si riserva il diritto e la facoltà di apportare modifiche di qualsiasi genere, in qualsiasi momento e senza preavviso, sia a questo documento sia ai propri prodotti.

Due to Cemp's policy of continuous development and improvement, the company reserves the right to supply products which may differ slightly from those illustrated and described in this publication.

Néanmoins, compte tenu de notre politique de développement et d'amélioration continue des produits, la Société Cemp se réserve le droit et la faculté d'apporter toute modification sur la documentation et sur les produits, à tout moment et sans préavis.

In keinem Fall können jedoch die in diesem Dokument aufgeführten technischen Daten als rechtlich verbindlich angesehen werden.

No obstante, como consecuencia de la política de continuo desarrollo y mejora de la calidad del producto que Cemp pone en práctica, la sociedad se reserva el derecho y la facultad de modificar en lo que fuera necesario, en cualquier momento y sin que para ello medie preaviso alguno, tanto este documento como sus productos.

Le descrizioni e le caratteristiche tecniche della presente pubblicazione non sono quindi impegnative e i dati riportati non costituiscono, in nessun caso, impegno contrattuale.

Descriptions and technical features listed in this brochure may not be considered as binding. Under no circumstances should data in this publication be considered as a contractual obligation.

Les descriptifs et les caractéristiques techniques contenus dans ce catalogue n'engagent pas la Société. Par conséquent, ces données ne constituent en aucun cas un engagement contractuel.

Cemp behält sich das Recht vor, ohne Mitteilung, jegliche Abweichungen und Änderungen jederzeit vorzunehmen, sowohl in diesem Dokument als auch bei den Produkten, die hier beschrieben sind.

Por lo tanto, las descripciones y las características técnicas indicadas en el presente documento no son vinculantes, y los datos que contiene no constituyen en ningún caso, vínculo contractual.



Cemp srl

Via Piemonte, 16
20030 Senago (Milano) - Italy
Tel. +39 02 94435401
Fax +39 02 9989177
cemp@cemp.eu

Cemp France sas

6, Avenue Victor Hugo
27320 Nonancourt - France
Tél. +33 (0)2 32580381
Fax +33 (0)2 32321298
cemp-france@cemp.eu

Cemp International GmbH

Dr. Atzinger-Strasse 5
94036 Passau - Germany
Tel. +49 (0)851 9662320
Fax +49 (0)851 96623213
cemp-deutschland@cemp.eu

Cemp srl - Middle East

GT3, Office 001
Jebel Ali Free Zone - Dubai - UAE
Mobile: +97 155 4718198
cemp-uae@cemp.eu



Cemp srl

Via Piemonte, 16
20030 Senago (Milano) - Italy

www.cemp.eu - www.regalbeloit.com

A Regal Brand

