

SIEMENS

SIPART

Controllers - Positioners -
Software

Supplement January 1999
to Catalog MP 31 · 1998

Supersedes:
Catalog MP 31 · 1998, Section 7

SIPART DR

DR24 multi-function unit
Input/Output module
3AO/3DI

7

Appendix

Conditions of sale and
delivery
Year 2000 compatibility

The products and systems described in this catalog are sold under application of a quality management system certified by DQS in accordance with DIN EN ISO 9001 (Certificate Registration No.: 19656-04). The DQS Certificate is recognized in all EQ Net countries (Reg. No.: 19656).



REG. NO. 16656-04

- NEW -
with extended
scope of functions

SIPART DR24 Multi-function Unit

7

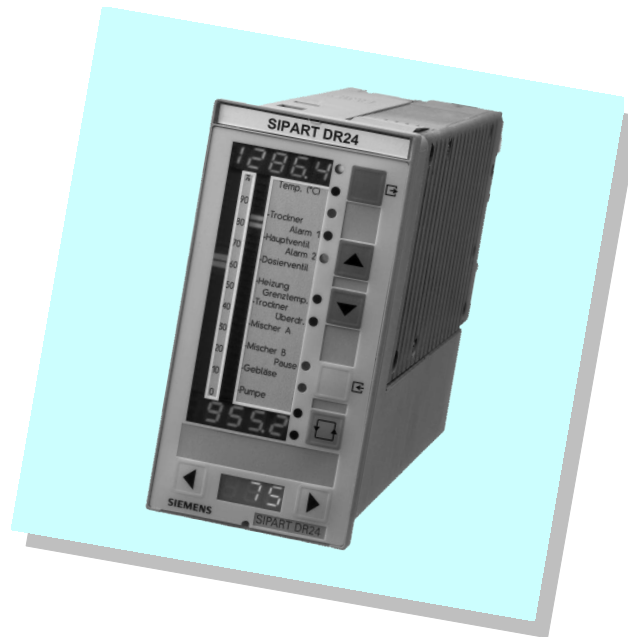

| | Page |
|--|------|
| Description | 7/2 |
| Application | 7/2 |
| Design | 7/3 |
| Mode of operation | 7/3 |
| Basic functions | 7/7 |
| Complex functions | 7/8 |
| Serial interface | 7/16 |
| Technical data | 7/17 |
| Ordering data | 7/19 |
| Input/output modules for SIPART DR24 | 7/20 |
| Summary of Applications | 7/20 |
| Module 3AO/3DI (6DR2802-8B) | 7/21 |
| Further modules: see Catalog MP31 · 1998, Section 8 | |
| Appendix | 7/22 |

SIPART DR24 Multi-function Unit

6DR2410-

Description

Application

The SIPART DR24 multi-function unit is used in process engineering applications for calculation, closed-loop and open-loop control. The unit can be freely configured to suit the application. During configuring, functions stored in memory (Fig. 7/1) are, through simple allocation, selected and connected to one another, to the inputs and outputs, and to the indicators and pushbuttons of the control and display unit.

No programming knowledge is necessary.

The multi-function unit can be connected to higher level automation systems, control systems or process computers using analog, parallel interfaces, as well as via an addressable bus-based serial interface.

The multi-function unit can be installed in panels, desks or cabinets.

Application examples

- Calculator for mathematical equations, timing sequences, logic operations and arithmetic operations executed in parallel
- Programmer (clock), also in conjunction with calculations, open-loop and closed-loop controls
- Closed-loop controller with continuous manipulated variable and/or three-position step controller; inputs and outputs of controller blocks freely connectable, e. g. to calculation and

- open-loop control functions; as a single-loop controller or for parallel operation for up to 4 independent control loops, for selection controls, cascade control, SPC or DDC mode
- Program controller; up to 8 programs
- Boiler control with mathematical evaluation of process variables (min./max. selection, correction computer etc.)
- Closed-loop burner control with open-loop control functions
- Thermodynamic closed-loop process control and calculations (enthalpy)
- Closed-loop furnace and zone control with programmed setpoint control and linearization
- Open-loop and closed-loop test bed control
- Closed-loop control of transport systems (e. g. conveyor belts) with dead time element
- Surge limit control
- Transmitter for analog and digital process variables to and from the serial interface (SIPART SW program)
- Process monitoring (limit violations, failure alarms etc.)
- Dependent and mutually interlocking/overriding setpoint control
- Multiplexer for process variables and/or setpoints
- Weighted average calculation using sampled values

| | | | |
|-------------------------------|---|---|--|
| <u>Mathematical functions</u> | | <u>Logic functions</u> | |
| AbS | Absolute value | And | AND |
| Add | Add | dFF | d flip-flop |
| AMPL | Differential amplifier | Eor | Exclusive OR |
| div | Divide | nAnd | NAND, also inverted |
| FUL | Function generator (3) | nor | NOR, also inverted |
| FUP | Function generator (2) | or | OR |
| LG | Log base 10 | tFF | t flip-flop |
| LinE | Straight line equation | tiME | Timer |
| Ln | Log base e | CoUn | Counter |
| MuLt | Multiply, negation | PUM | Pulse width modulation (4) |
| Pot | Exponentiation | | |
| CPT | P/T correction computer (2) | <u>Switches</u> | |
| root | Square root extraction | MUP | Multiplexer (2) |
| SUB | Subtract, negation | ASo | Analog variable selector |
| SPr | Splitrange (8) | bSo | Digital variable selector |
| | | Cnt | Demultiplexer |
| <u>Time functions</u> | | <u>Memory functions</u> | |
| AFi | Adaptive filter (2) | AMEM | Analog value memory |
| diF | Differentiate (high-pass) | dFF | d flip-flop |
| FiLt | Filter (low-pass) | Ain | Integrator with analog input, tracked (see above) |
| Ain | Integrator, analog input (4) | bin | Integrator with digital input, tracked (see above) |
| bin | Integrator, digital input (6) | MAME | Maximum memory |
| tiME | Timer | MiME | Minimum memory |
| dTi | Dead time element (2) | tFF | T flip-flop |
| CLoc | Programmer (1) | | |
| <u>Comparison functions</u> | | <u>Programmer</u> | |
| dEbA | Response threshold | CLoc | Clock (see above) |
| LiMi | Limiter | | |
| MASE | Max. selection | | |
| MiSE | Min. selection | | |
| AMPL | Differential amplifier | | |
| CoMP | Comparator with hysteresis | | |
| <u>Control functions</u> | | Functions marked (x) are complex functions that may be used x times (x = 1, 2 or 3). All other functions are basic functions that can be connected in any sequence and as often (max. = 109) as required. | |
| Ccn | } PID controller with continuous output | The abbreviated function names are displayed in the seven-segment display during parameterization and configuring. | |
| CSE | | } S controller with internal or external feedback (4) | |
| CSi | | | |

Fig. 7/1 Basic and complex functions of the multi-function unit

Description



Fig. 7/2 SIPART DR24 multi-function unit

Design

The SIPART DR24 multi-function unit is of modular design and consequently easy to service and simple to reconfigure or retrofit. It consists of a standard device, to which additional input/output modules can be added in order to extend its range of application. These modules are inserted in slots in the rear of the instrument (Fig. 7/3).

The standard device comprises:

- the front module with controls and displays
- a main circuit board with CPU and terminal strips
- plastic moulded housing with an interface board and power pack.

Electrical connections between the various modules are made via the interface board fixed to the housing. The main circuit board is inserted in the rear of the unit in slot 1 and locked in place. The main board has 10-pin and 14-pin terminal blocks to which all inputs and outputs of the standard device are connected. If the number of signals in the standard device is insufficient for a particular application, a further five slots are available for additional option modules.

Electrical power for transmitters is provided by a short-circuit proof L^+ -output (DC 24 V, 100 mA).

The power supply unit, an electrically isolated, stabilised switched-mode power pack, is situated in a completely enclosed metal housing that is screwed to the plastic body of the instrument.

Versions available:

- 6DR2410-4 for AC/DC 24 V power supply
- 6DR2410-5 for AC 230 V power supply, switchable to AC 115 V.

Short dips in the power supply are bridged without affecting the instrument's functionality. All voltages generated by the power pack are stabilised and short-circuit proof (thermal fuse and current monitoring).

The input of the power pack is protected against overvoltages. A filter ensures that mains glitches cannot reach the instrument and that switching surges from the power pack are prevented from getting into the mains supply.

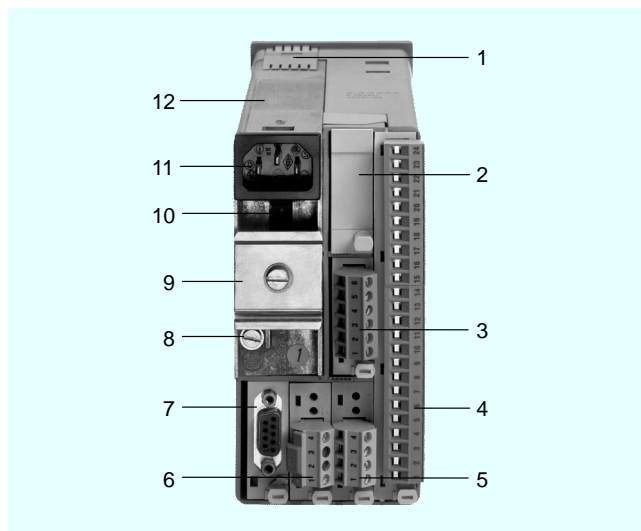

- 1 PE conductor - contact spring
- 2 Slot 6
- 3 Slot 5
- 4 Slot 1 (main circuit board)
- 5 Slot 2
- 6 Slot 3
- 7 Slot 4 (SES: RS 232/RS 485, PROFIBUS-DP)
- 8 Earthing screw
- 9 Top-hat rail (included in delivery of relay modules)
- 10 Mains voltage selector
- 11 Mains plug
- 12 Power supply unit

Fig. 7/3 SIPART DR24 multi-function unit, rear view

The output from the power pack is sufficient to provide a 24 V supply to a number of loads (active digital outputs, output modules) connected to earth (see Technical data).

Mode of operation

The SIPART DR24 multi-function unit is designed around a modern, highly-integrated CMOS microprocessor.

The task-specific program created by the user is stored in a non-volatile memory and is therefore protected against power failure.

The A/D and D/A converters allow the digital circuits to be connected to the analog interfaces of the I/O signal converters. Data communication with the plug-in Hardhold module, which also contains a microprocessor, is implemented by an internal serial interface.

Analog input area

The standard device has 3 electronically isolated analog inputs that can accept either standardized voltage (0/0.2 to 1 V or 0/2 to 10 V) or current (0/4 to 20 mA) signals.

In addition to these inputs, a module with 3 further inputs of identical types can be inserted into slots 5 and 6. These inputs can also be switched between 0 to 10 V and 0/4 to 20 mA. To handle complex control applications, or to connect other input signals, two additional input modules can be inserted in slots 2 and 3. Apart from processing standardized voltage and current signals, these input modules can also be used to connect Pt 100 resistance thermometers, thermocouples and resistance based sensors.

A total of 11 analog inputs are therefore available.

SIPART DR24 Multi-function Unit

6DR2410-

Description

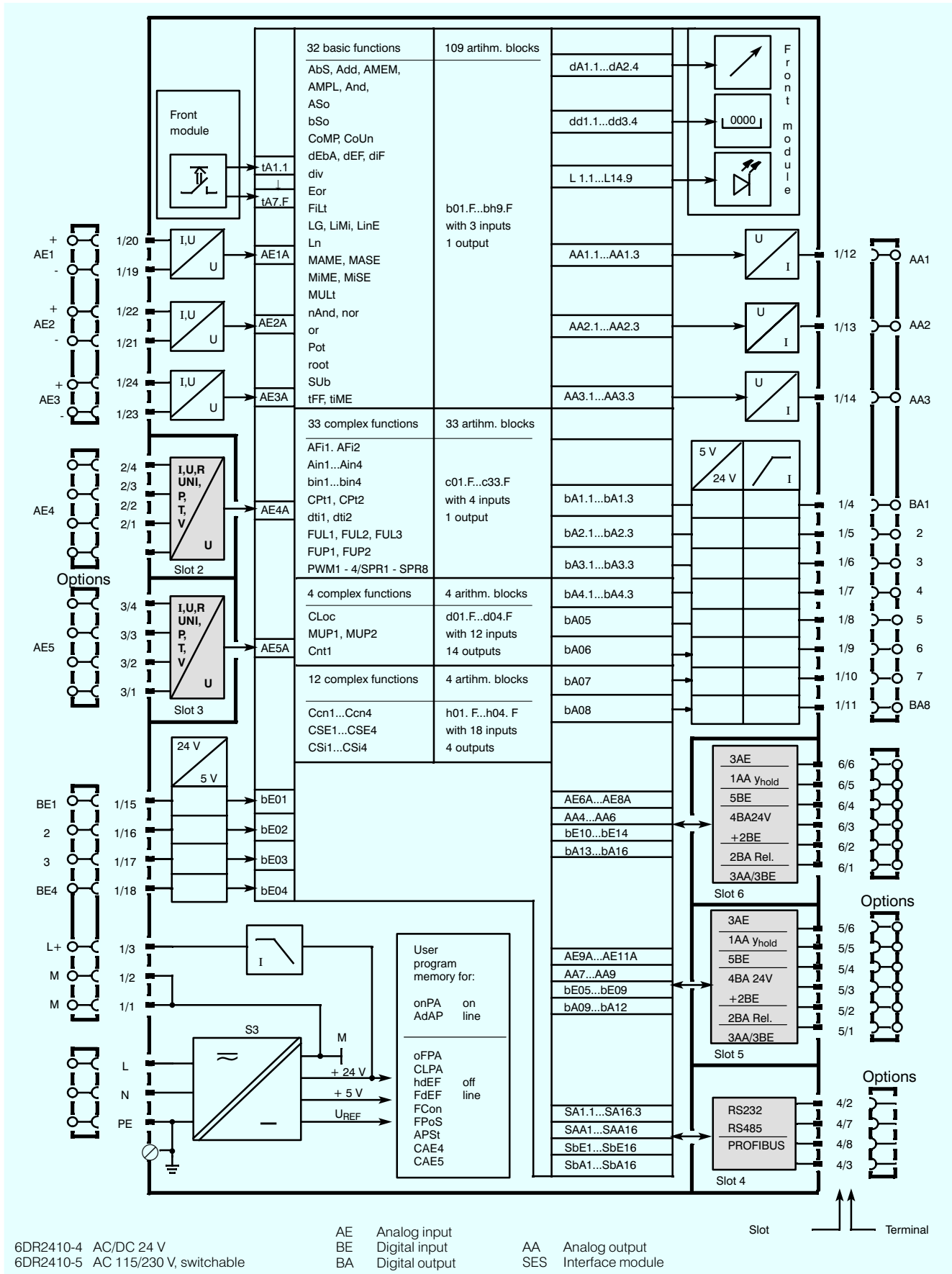

Fig. 7/4 SIPART DR24 multi-function unit, function diagram

Optional

Description

Analog output area

The standard device has 3 analog outputs. In addition to these outputs, a module with 3 analog outputs and 3 digital inputs can be inserted into each of the slots 5 and 6. The total of 9 analog outputs generate a 0 to 20 mA or 4 to 20 mA signal.

Slots 5 and 6 can be optionally fitted with an analog output module (y-hold). This module consists of a microprocessor which outputs the manipulated variable it receives from the CPU on the main circuit board. It also contains an alarm output $\bar{S}I$. In normal mode the module is powered by the controller's power pack. It can, however, also be powered via an external DC 20 to 30 V supply, in which case the internal and external supply are ORed.

This analog output module holds the most recent value of the output variable should communications between the controller's CPU and the y-hold processor fail.

Digital I/O area

The standard device has 4 digital inputs (BE1 to BE4) and 8 digital outputs (BA1 to BA8). If more are required, the number of digital inputs and outputs can be increased by using additional option modules. Slots 5 and 6 at the rear of the controller are used for this purpose. Both these slots can be used to accommodate either a module with 5 digital inputs, or one with four DC 24 V digital outputs, or a module with two relay outputs ($\leq AC/DC 35 V, \leq 5 A$).

The digital outputs are active and generate a DC 24 V signal.

Floating outputs are available, if the relay module with two digital outputs is used. An interface relay module can also be snapped onto a DIN rail on the rear of the controller. This additional module has either two or four relays, which are energized directly by the digital outputs. Each relay has a single CO contact.

Function area

The function area is located between the input and output areas. It contains

32 basic functions, that can be used as required up to 109 times, and

15 reusable complex functions.

The function area also contains variable parameters and a number of constants and alarms that may also be connected as necessary.

In the configuring mode, the required functions can be selected or defined (configuring mode FdEF), connected (configuring mode FCon) and positioned in the processing sequence (configuring mode FPoS).

The software connections are freely configurable. Any data source can be connected to any number of data sinks. Configuring is minimised by eliminating the data sources and sinks of undefined function blocks and by removing any illogical source/sink (e. g. analog to digital) connections.

Certain parameters can be modified during operation (on-line parameters). The remaining dedicated parameters (e. g. programmer parameters) are set off-line in configuring mode.

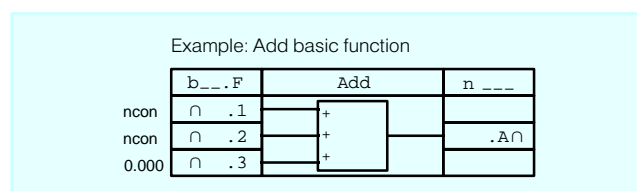

$A = E1 + E2 + E3$
ncon Inputs not connected

Fig. 7/5 Basic function block, adder; the preallocated inputs e. g. E3 = 0.000) can be easily overwritten if required

Arithmetic

Analog variables are processed using floating-point arithmetic within a decimal range of -10^{19} to $+10^{19}$.

The input and output variables of the multi-function unit are input or output in the signal range 0/4 to 20 mA or 0 to 10 V, corresponding to 0 to 100 %. These ranges represent the arithmetic values 0 to 1. Arithmetical operations are performed using these numeric values.

- Connectable parameters

The linear parameters PL1 to PL40 can be adjusted with a resolution of 4 digits. The parameters Pd1 to Pd40 - which should preferably be used as time constants - can be adjusted over a very large logarithmic range. PL and Pd parameters can be modified on-line in process operation.

- Back-up battery RAM

Actual values of counters, timer and memory functions can all be stored in the event of a power supply failure.

Function area "Basic and complex functions"

Configuring mode FdEF is used to define any number of function blocks in any sequence. The data sinks (inputs) can be connected (FCon) to any data source (output), e. g. to outputs from other blocks, to parameters or arithmetic variables. The basic functions and their abbreviated names are shown in Fig. 7/1. The basic function blocks and their characteristic features are listed on page 7/7.

The complex function blocks and their characteristic features are listed on pages 7/8 to 7/14.

SIPART DR24 Multi-function Unit

6DR2410-

Mode of operation

- Communication with higher-level systems

The SIPART DR24 controller can transmit and receive status flags, process variables, parameters and configuring switch settings via an interface module (option).

The following interface modules are available:

PROFIBUS DP module

- Transmission rate up to 1.5 Mbits/s
- Address range up to 125
(number of possible stations on the PROFIBUS is determined by the master interface module, the data range of the interface module, and the number of parametrized process data)

SES module RS 232/RS 485

- Transmission rate 9.6 kbits/s
- RS 232 as point-to-point connection or SIPART bus up to 32 stations
- RS 485 bus up to 32 stations

Monitoring function

The multi-function unit contains monitoring functions. Alarms are available as data sources and can be used to activate digital outputs, initiate function sequences or, for example, set analog outputs to their safety values.

- Self-diagnosis

Comprehensive self-diagnostics circuits cyclically control the internal data transfer, or also following a power-on reset or watchdog reset.

An error message is displayed automatically on the front module when an error is detected. This message provides enough information to identify the cause of the error and shows how it can be rectified.

If the analog output module is being used, the $\bar{S}T$ digital output on this module interrupts the High signal present during normal operation.

- Restart conditions

Depending on the actual loading on the instrument, short dips in the power supply are bridged by the storage capability of the power pack. During a longer power cut, the parameters and configurations being used are saved in a non-volatile, plug-in user program memory. The most recent mode of operation, setpoint value and manipulated variable are also loaded into fail-safe memory.

If the SIPART DR is equipped with an analog output module and is being supplied from a separate, fail-safe source, the most recent output value is maintained.

- Blocking of operator input as well as parameterization and configuring modes

Switching over to parameterization and configuring mode can be blocked using digital signals.

The digital input BLS blocks the switchover to configuring mode. However, on-line control parameters can still be set and adaptation, as well as normal process operation, performed.

The digital input BLPS, on the other hand, prevents the instrument from being switched out of process operation mode.

The binary function bLB blocks operation of the device.

Indicators (Fig. 7/2)

The SIPART DR24 multi-function unit is equipped with digital and analog indicators.

The two analog indicators consist of a red and a green vertical LED array. One or two diodes light up alternately, with the measured value indicated by the center of the field.

The resolution of both indicators is 1.7 %. The green LED array on the right can be configured as a digital indicator, in which case digital signals are output to 10 equally spaced LEDs. Two of the three digital indicators have 4½-digit displays, and one has a 3-digit display. They can all be dimensioned in either engineering units or percentage.

13 additional LEDs are located on the front of the instrument to display status flags, alarm conditions etc. All LEDs can be connected as required.

Process operation (Fig. 7/2)

7 freely connectable pushbuttons are provided on the front panel, which are operator-accessible by pressing the curved foil.

All control and display elements (indicators, LEDs and input pushbuttons) on the front panel can be switched over to 4 data sources or sinks for multiple applications.

Customised descriptions can be inserted on the front panel.

The rating plate can also be replaced.

Description

Basic functions

A total of 32 basic functions can be used up to 109 times in any sequence: b01.F to bh9.F

ncon Input not yet connected
 Hi; Lo; 1.00; Present for input; can be overwritten
 Hi High level
 Lo Low level

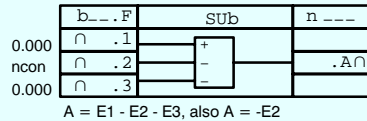
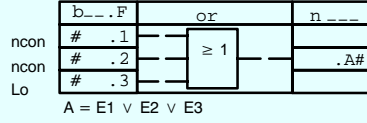
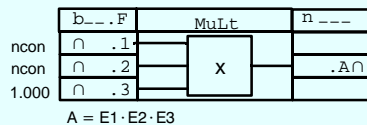
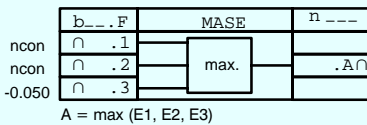
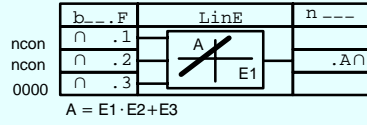
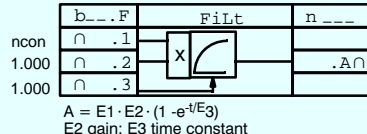
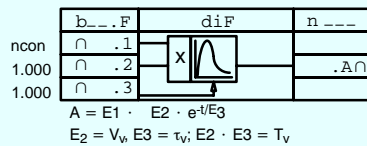
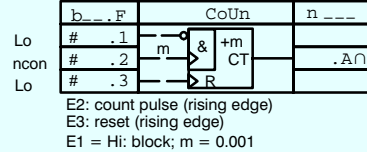
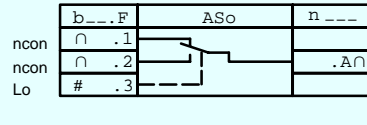
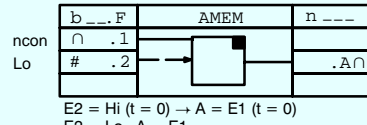
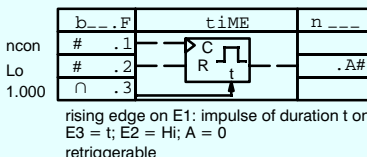
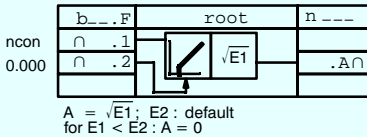
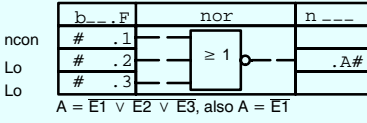
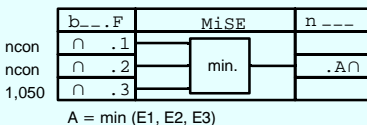
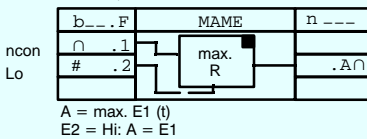
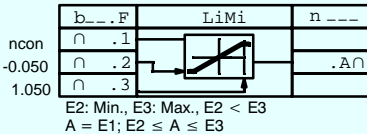
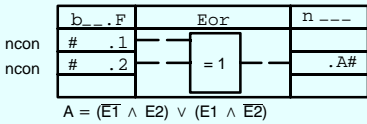
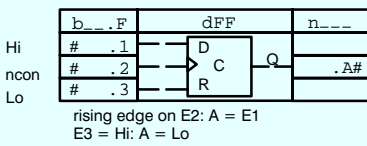
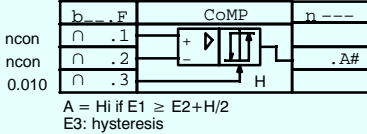
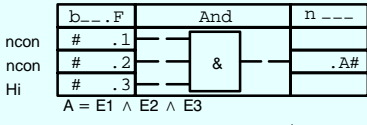
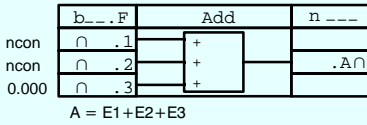
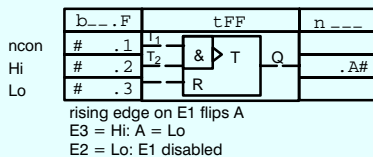
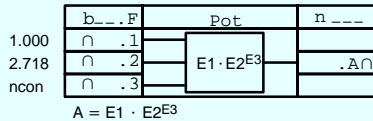
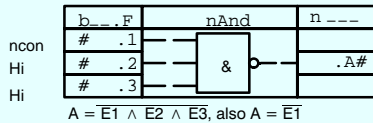
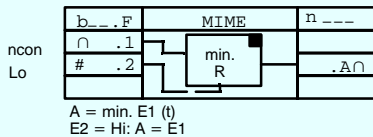
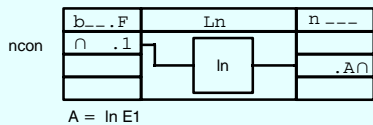
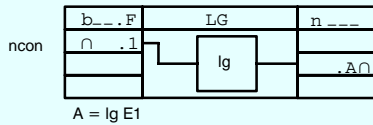
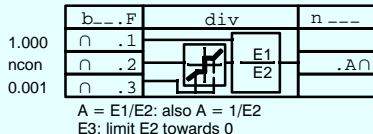
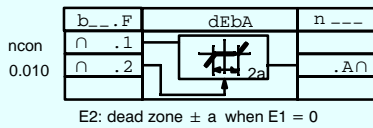
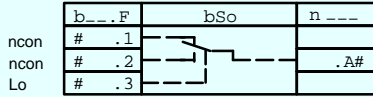
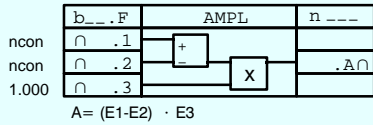
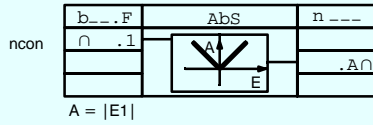
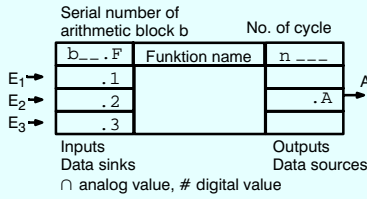

SIPART DR24 Multi-function Unit

6DR2410-

Description

Complex functions (functions with dedicated parameters)

Adaptive filters AFi1 and AFi2

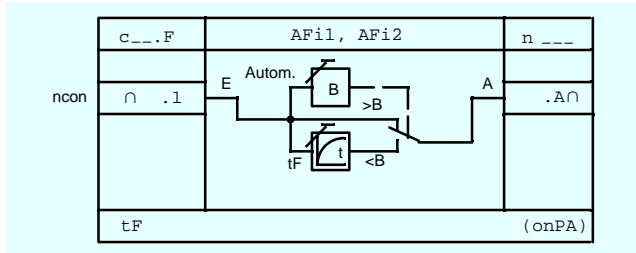

Filter time constant
 $t_F = \text{off}, 1 \text{ to } 9984 \text{ s}$

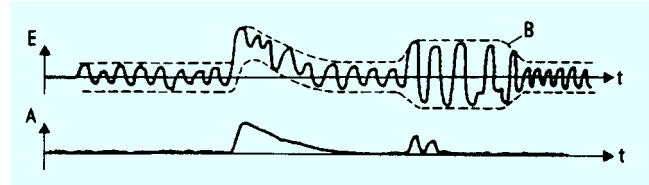

A Output signal B Filter band E Input signal
 Fig. 7/6 Effect of the adaptive non-linear filter

The adaptive filter AFi* dampens oscillations in the input variable, which occur repeatedly within a band *B*, using a variable time constant *t_F*. Changes outside the band are applied unfiltered to the output. If the noise level changes, the band is automatically adapted to the new level. Noise - e.g. from a

process variable - is thus suppressed without affecting the detection of rapid changes. This is important in controlled systems where rapid settling is required.

Dead-time elements dti1 and dti2

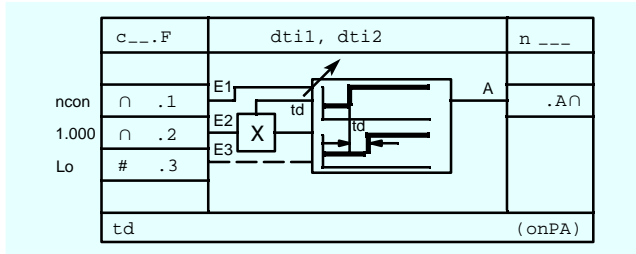

Output = input offset by time *td*:

Dead time t_d 1 to 9984 s

Stored values $100/t_d$, max. 1/cycle

After "Power on": $A = 0$ for $t \leq t_d$

This dead time is multiplied with a factor in E2 and is therefore changed from outside. The dead time element can be "stopped" at any time via input 3. The profile remains during "standstill". $E3 = \text{Hi} \rightarrow$ "standstill".

Function generators FUP1 and FUP2

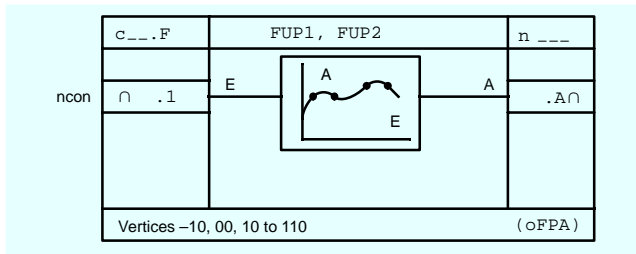

Curve calculator with 13 vertices between -10 and +110 % of the input signal range:
 parabolic approximation

Output -199.9 to +199.9 %; magnitude per vertex can be parameterized.

7

Function generators FUL1, FUL2 and FUL3

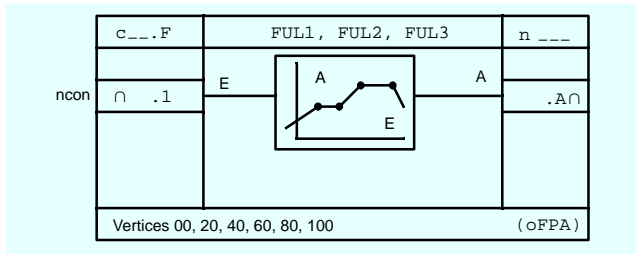

Curve calculator with 6 vertices between 0 and 100 % of the input signal range.

The output function is formed by the straight sections between the vertices.

The function generators can be used, for example, for parameter control in the controller function blocks *h_..F*.

Integrator with analog input Ain1 to Ain4

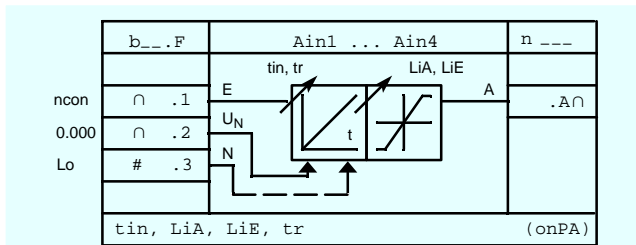

The analog variable on input .1 is integrated.

Tracking mode ($N = \text{Hi}$): the memory *A* of the integrator is made to track the value of the analog variable U_N with t_r . Input .1 has no effect as long $N = \text{Hi}$. The integrator acts as an analog value memory when $E.1 = 0$ and $N = \text{Lo}$.

$$A = \frac{1}{tin} \int_0^t E.1 dt + U_{No} \quad \begin{array}{l} N \text{ Tracking signal} \\ U_N \text{ Tracking variable} \end{array}$$

t_{in} 1 to 9984 s Integrating time
 LiA -199.9 to +199.9 % Start-of-scale value
 LiE -199.9 to +199.9 % Full-scale value
 t_r off, 1 to 9984 s Tracking time (ramp)

Description

Integrator with digital inputs bin1 to bin6

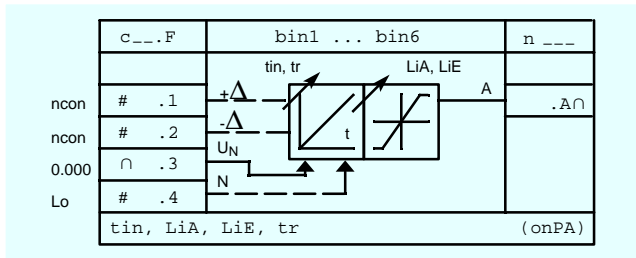

Digital input signals can be generated e. g. by pressing pushbuttons.

Possible applications:

- adjustment of analog values using front panel pushbuttons
- ramp functions.

The variables N and U_N enable the stored value to track external variable (U_N) with tr , e. g. for x-tracking, for adaptation of w_{int} to w_{ext} , or for adaptation of y_H to y_A for automatic, bumpless switchover when using the controller.

Integration is enabled by the digital signals on .1 or .2.

Tracking mode ($N = Hi$): memory A of the integrator is made to track the value of the analog variable U_N with tr . The inputs .1 and .2 have no effect as long as $N = Hi$.

The integrator acts as an analog value memory when $E.1 = 0$ and $E.2 = 0$ and $N = Lo$.

$$A = \frac{1}{tin} \int_0^t \pm 1 dt + U_{No}$$

The integration time is progressive (100 % approx. 23 s) and constant when $tin = 1$ to 9984 s.

| | | | |
|-------|--------------------|----------------------|---------------------|
| LiA | -199.9 to +199.9 % | Start-of-scale value | } memory limitation |
| LiE | -199.9 to +199.9 % | Full-scale value | |
| tr | off, 1 to 9984 s | Tracking time (ramp) | |

Correction computers CPT1 and CPT2

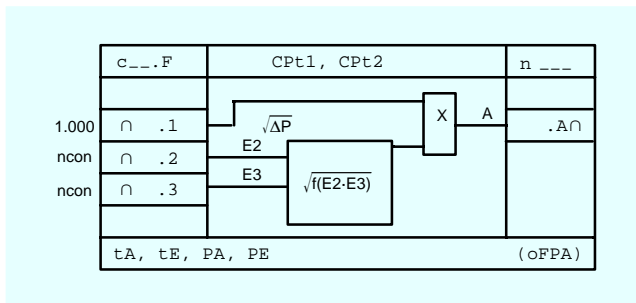

Correction computers are used to calculate the rate of flow of gases from the differential pressure p , correcting for fluctuations in pressure and temperature. Mass flow and volume flow based on the operational state can be corrected, as well as volume

flow based on standard state. The medium must be in a pure state, i. e. separation must not occur. The output variable A is calculated as follows:

$$A = \sqrt{\Delta p} \cdot \sqrt{f(E_2, E_3)}$$

$$f(E_2, E_3) = \frac{(P_E - P_A) E_2 + P_A}{(t_E - t_A) E_3 + t_A}$$

The measuring range is standardised to the formula using the parameters t_A , t_E , P_A and P_E . t_A and P_A can take a value between 0.01 to 1.000, t_E and P_E between 1.000 to 99.99.

This flow correction computer corrects errors caused by changes in the state variables of the medium (pressure, temperature).

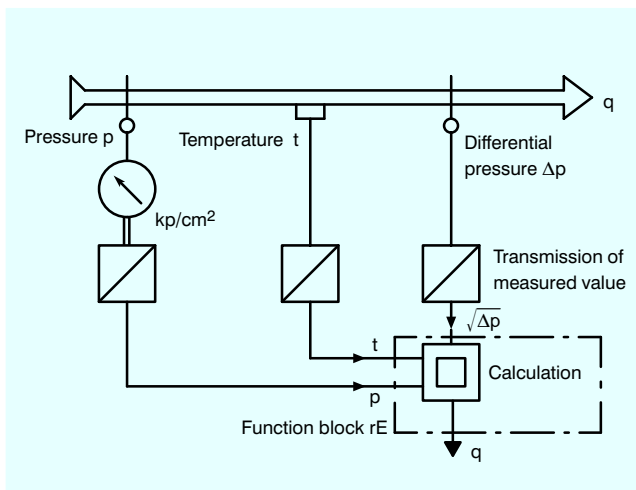

SIPART DR24 Multi-function Unit

6DR2410-

Description

Split range SPPr1 to SPPr8

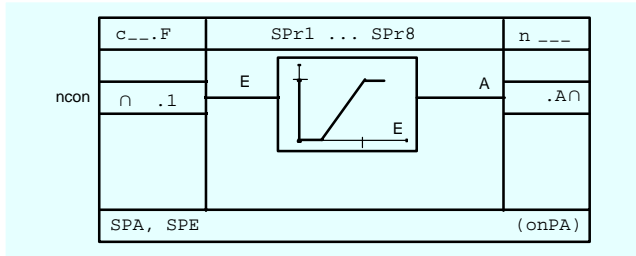

The split range function comprises a straight-line equation between the base point SPA (output value 0) and the turning point SPE (output value 1).

Outside this range, the output is limited to 0 or 1. By setting the two private onPA parameters SPA and SPE it is possible to implement both rising and falling sections.

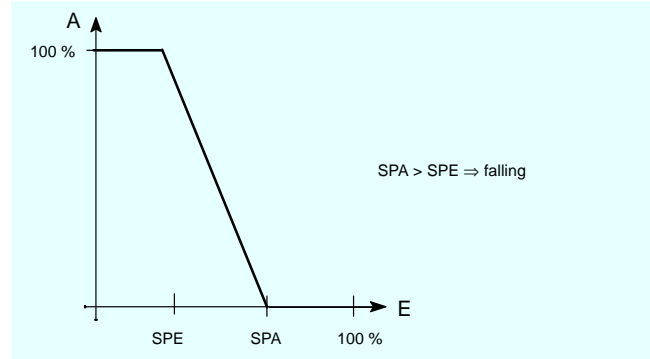
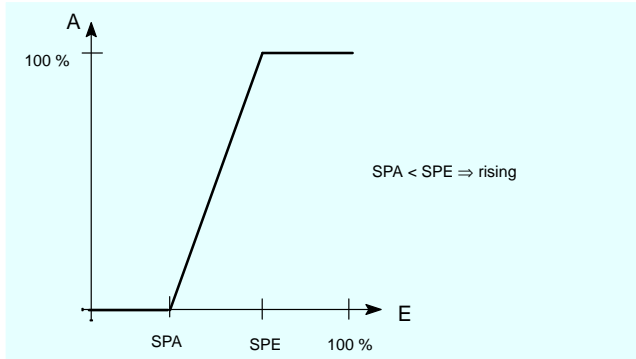

Pulse-width modulator

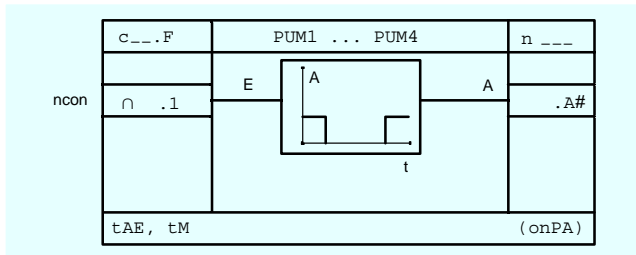

The pulse-modulator converts an analog signal into a pulse-width-modulated binary signal.

Private parameters (onPA)

- tM Period
- tAE Minimum on time

Example:

Input value: 0.3

Period: 4 s

⇒ On time 1.2 s

Pause time 2.8 s

Measuring-point selector MUP1, MUP2 (multiplexer)

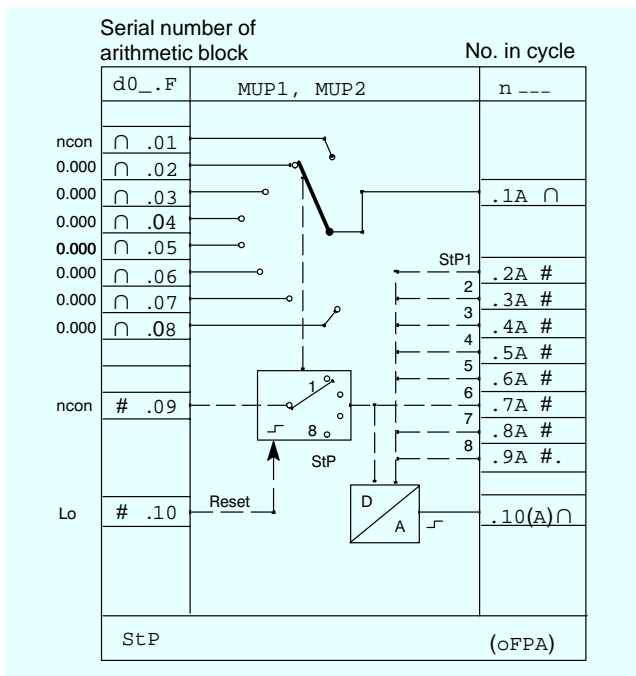

The multiplexer enables up to 8 analog inputs to be switched through to a single output. This switching operation is controlled by the signal on the cycle input d0*.09 (switch over in a closed ring). Each switching signal is indicated by a Hi signal on a separate output. These signals can, for example, be connected to the programmer's inputs to select a particular program. In addition, the current position can be displayed by connecting the d0*.10 output to the digital display dd3.

The StP parameter (number of switching steps) is used to select the maximum number of measuring points (2 to 8). The factory setting is 8.

Description

Demultiplexer Cnt1

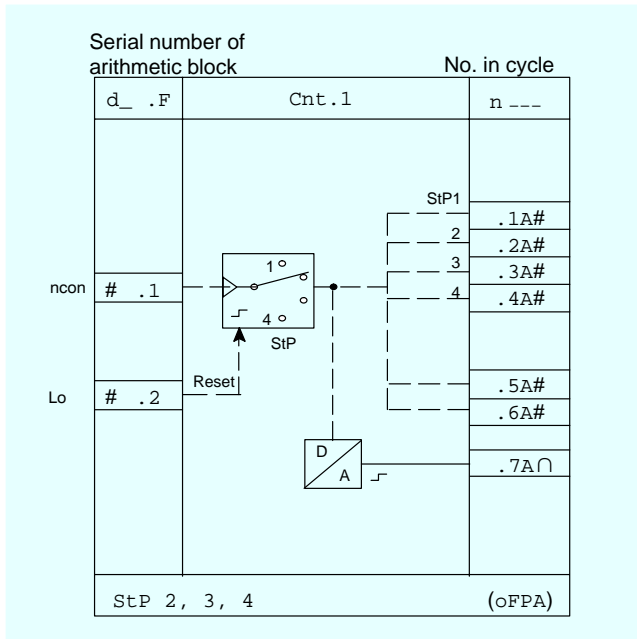

The multiplexer is primarily used for switching over the display and control elements (multiple controller, max. 49).

It can be defined once. The demultiplexer is used to output the counter value in binary code according to the following table. Enabling is carried out controlled by the edge at the clock input d*.1 (switching over in closed ring, limited by private parameter StP).

The counter can be set to position 1 by a High signal via the Reset input d*.2. The position can be displayed by connecting the output to display dd3.

| StP | 1A | 2A | 3A | 4A | 5A | 6A |
|-----|----|----|----|----|----|----|
| 1 | 1 | 0 | 0 | 0 | 0 | 0 |
| 2 | 0 | 1 | 0 | 0 | 1 | 0 |
| 3 | 0 | 0 | 1 | 0 | 0 | 1 |
| 4 | 0 | 0 | 0 | 1 | 1 | 1 |

Controller blocks Ccn1 to Ccn4, CSi1 to CSi4 and CSE1 to CSE4

Four of the controller blocks listed below can be used in each instrument, independent of the type of controller.

Input signal conditioning takes place outside the controller block. The controllers have inputs for the control deviation.

Inputs

- h0*.01 : Av Enable adaptation input
- h0*.02 : x Resulting controlled variable for adaptation
- h0*.03 : yz Disturbance variable feedforward to manipulated variable y_a

- h0*.04 : xd_p
 - h0*.05 : xd_I
 - h0*.06 : xd_D
- } control deviation inputs

The controlled variable or another process variable can be differentiated instead of the deviation x_d (dynamic disturbance variable feedforward)

- h0*.07 : P Control signal for changing structure
- P = Lo: PI, PID
P = Hi: P, PD

P = Lo → PID (z):

$$y_a = y_z + x_{wp} \cdot K_P + x_{wI} \cdot K_P \left(1 + \frac{1}{j\omega T_n}\right) + x_{wD} \cdot K_P \frac{j\omega T_v}{1 + j\omega \frac{T_v}{V_v}}$$

P = Hi → PD (z):

$$y_a = y_z + x_{wp} \cdot K_P + y_0 + x_{wD} \cdot K_P \frac{j\omega T_v}{1 + j\omega \frac{T_v}{V_v}}$$

with Y₀ = AUto: Working point automatically adjusted in manual mode so that Y₀ = Y_H in each case

with Y₀ ≠ AUto: Working point fixed at Y₀

- h0*.08 : H Control signal for switching operating mode of controller
- H = Lo: y = y_a (automatic mode)
H = Hi: y = y_H (manual mode)

- h0*.09 : +Δy
 - h0*.10 : -Δy
 - h0*.11 : +y_{BL}
 - h0*.12 : -y_{BL}
 - h0*.13 : SG1
 - h0*.14 : SG2
 - h0*.15 : SG3
 - h0*.16 : N
 - h0*.17 : Y_N
- } Digital inputs for incremental adjustment of manipulated variables (tracking or manual mode)
- } Digital inputs for direction-dependent blocking of manipulated variables
- } Controlled variable inputs for parameterized control of control parameters K_P, T_n and T_v.
- } Digital input for manual or tracking mode
- } Analog input for manual manipulated variable

Parameters

- cP Proportional gain
- tn Reset time
- tv Derivative action time
- wv Derivative action gain
- AH Response threshold
- Y₀ Working point
- Y_A Manipulated variable limitation, minimum
- Y_E Manipulated variable limitation, maximum
- t_γ Actuating time
- t_A Minimum pulse length
- t_E Minimum pulse interval

SIPART DR24 Multi-function Unit

6DR2410-

Description

K controller (with continuous output) Ccn1 to Ccn4

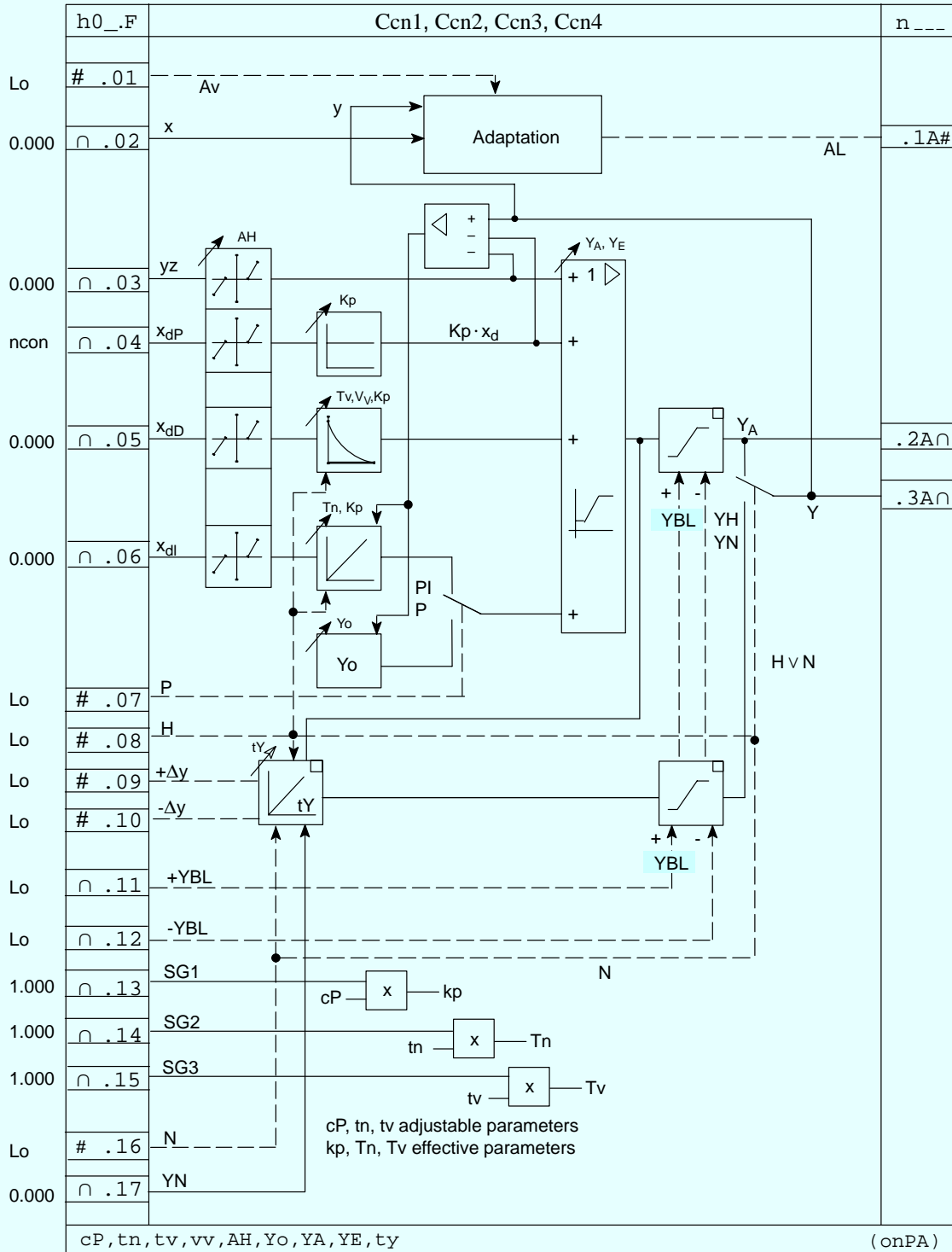

Outputs:

- h0*.1A: Digital output signal "Adaptation in progress"
- h0*.2A: Controller manipulated variable output signal (automatic mode)
- h0*.3A: Manipulated variable output signal (manual, tracking or automatic mode)

Description

S controller (with three-position step controller and internal positional feedback) CSi1 to CSi4.
 A positional feedback is not required with this controller, as the time response of the actuating motor is simulated by an integrator in the controller.

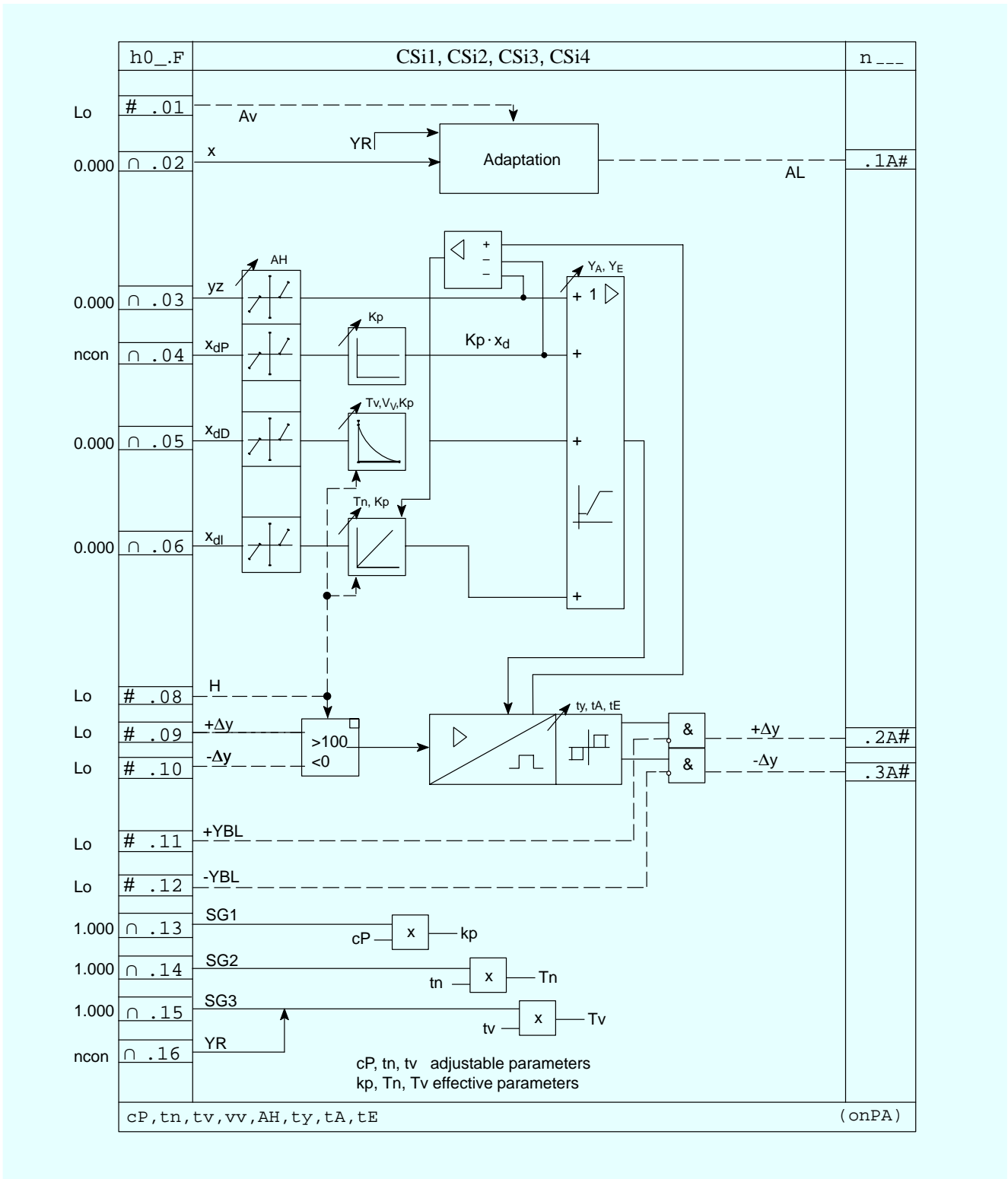

Outputs:

- h0*.2A: +Δy
 - h0*.3A: -Δy
 - h0*.16: Y_R
- } positional increments for the actuator
 } position feedback (for display only)

SIPART DR24 Multi-function Unit

6DR2410-

Description

S controller (with three-position step controller and external positional feedback) CSE1 to CSE4

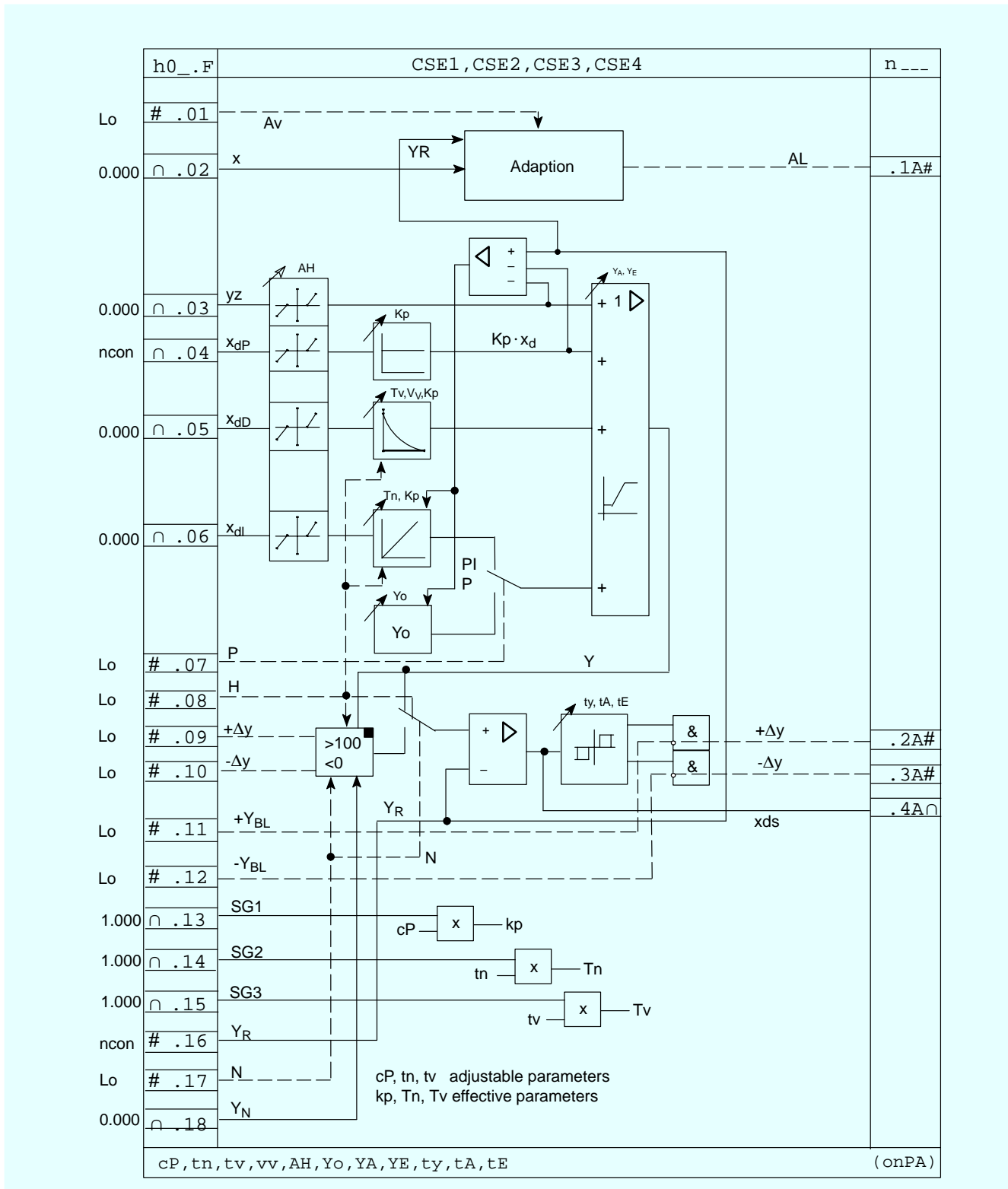

Outputs:

- $h0^*.2A:$ $+\Delta y$
 - $h0^*.3A:$ $-\Delta y$
 - $h0^*.4A:$ x_{ds}
 - $h0^*.16:$ Y_R
- } positional increments for the actuator
 control deviation of positional control loop
 position feedback

7

Description

Programmers

The programmer enables 2 analog outputs and 8 digital outputs to be assigned a common time basis with a maximum of 40 time intervals. These 40 intervals can be divided among up to 8 independent programs, each of which is assigned an appropriate number of time intervals.

The time intervals for the programs are entered in the selected format in either h/min or min/s. The values of analog outputs and/or the status of digital outputs are then allocated to each time interval. The specified programs can be executed once, more than once, and also cyclically. The clock can also be speeded up for testing purposes.

The clock is controlled via the Start, Stop, Reset and High-speed inputs. The program to be executed is selected using the d0*.05 to d0*.12 inputs, and started by setting Start = Hi. The timing sequence can be monitored via the "time from start", "time in interval", "interval" and "stop clock" outputs.

Parameters

CLFo : Clock format: h/min or min/s

CLCY: Number of cycles

CLSb: Acceleration factor

| Acceleration factor | Time | | | |
|---------------------|---------|--------|---------|-------|
| | 1 week | 1 day | 1 hr | 1 min |
| 360 | 28 min | 4 min | 10 s | - |
| 168 | 60 min | - | - | - |
| 120 | 84 min | 12 min | 30 s | 0.5 s |
| 60 | 168 min | 24 min | 1 min | 1 s |
| 24 | 7 h | 1 h | 2.5 min | 2.5 s |
| 12 | 14 h | 2 h | 5 min | 5 s |
| 6 | 28 h | 4 h | 10 min | 10 s |
| 3 | 56 h | 8 h | 20 min | 20 s |

CLPr : Number of intervals/program

CLti : Length of interval

CLA1, 2 : Analog output value 1 or 2

CLb1 to

CLb8 : Digital status Hi or Lo in respective interval

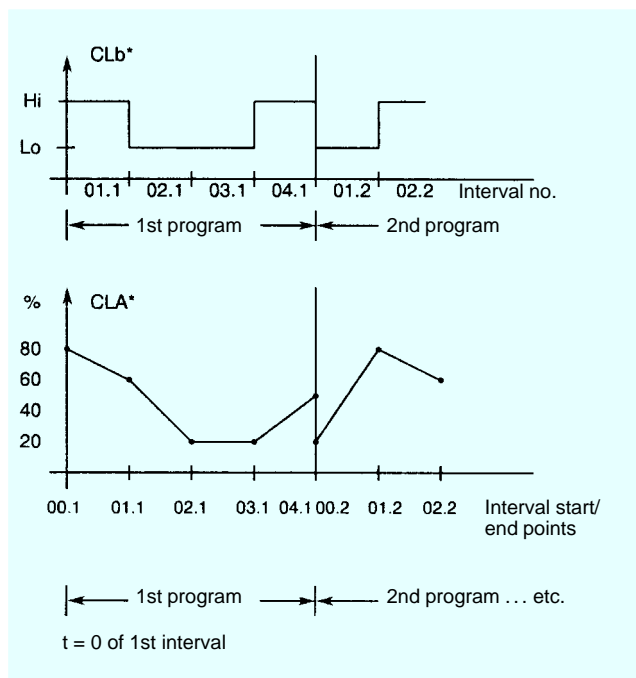
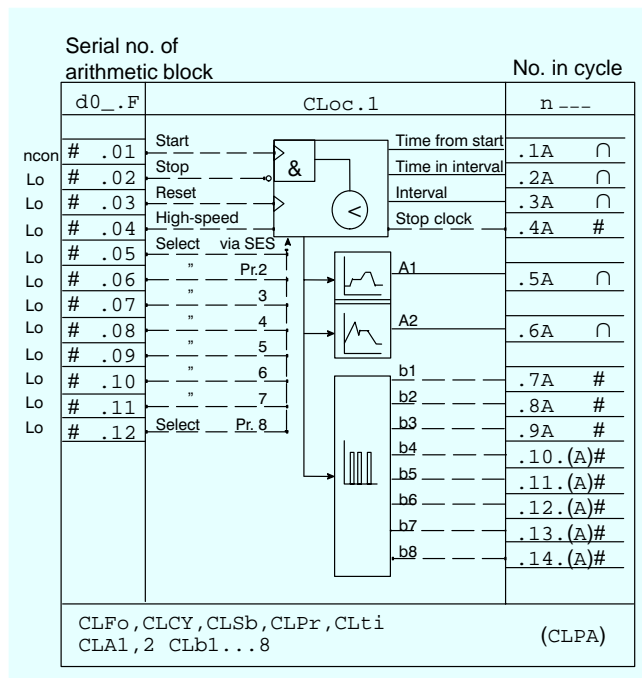

| Interval | CLA.. | CLb.. | Meaning of interval indicator | |
|----------|-------|-------|-------------------------------|--------------|
| | | | with CLA | with CLb |
| 00.1 | 80 % | - | Start 1st interv. (t=0) | - |
| 01.1 | 60 % | Hi | End 1st interval | 1st interval |
| 02.1 | 20 % | Lo | End 2nd interval | 2nd interval |
| 03.1 | 20 % | Lo | End 3rd interval | 3rd interval |
| 04.1 | 50 % | Hi | End 4th interval | 4th interval |
| 00.2 | 20 % | - | Start 1st interv. (t=0) | - |
| 01.2 | 80 % | Hi | End 1st interval | 1st interval |
| 02.2 | 60 % | Lo | End 2nd interval | 2nd interval |

Interval no. in display dd3

SIPART DR24 Multi-function Unit

6DR2410-

Description

Serial interface

Input and output functions of the serial interface

Freely connectable inputs and outputs (SAE, SbE and SAA, SbA respectively) and dedicated read-only inputs and outputs (AI, DI and AO, DO respectively) of the multi-function unit can be read/written by the SES. Parameters and configuring data can also be read/written.

The data sinks SA(E).1 (tracking variable) and SA(E).2 (tracking control signal) are used to track the data source SA.3 if a

bumpless changeover towards (SA(E).3 is to be made between this data source and another.

A cyclical watch-dog function can be used to monitor traffic on the interface. A monitoring period can be specified using the parameter Cbt; when the elapsed time between two telegrams exceeds this period, the digital input SbE1 is set to Lo. If required, this could be used to trigger changeovers within the multi-function unit.

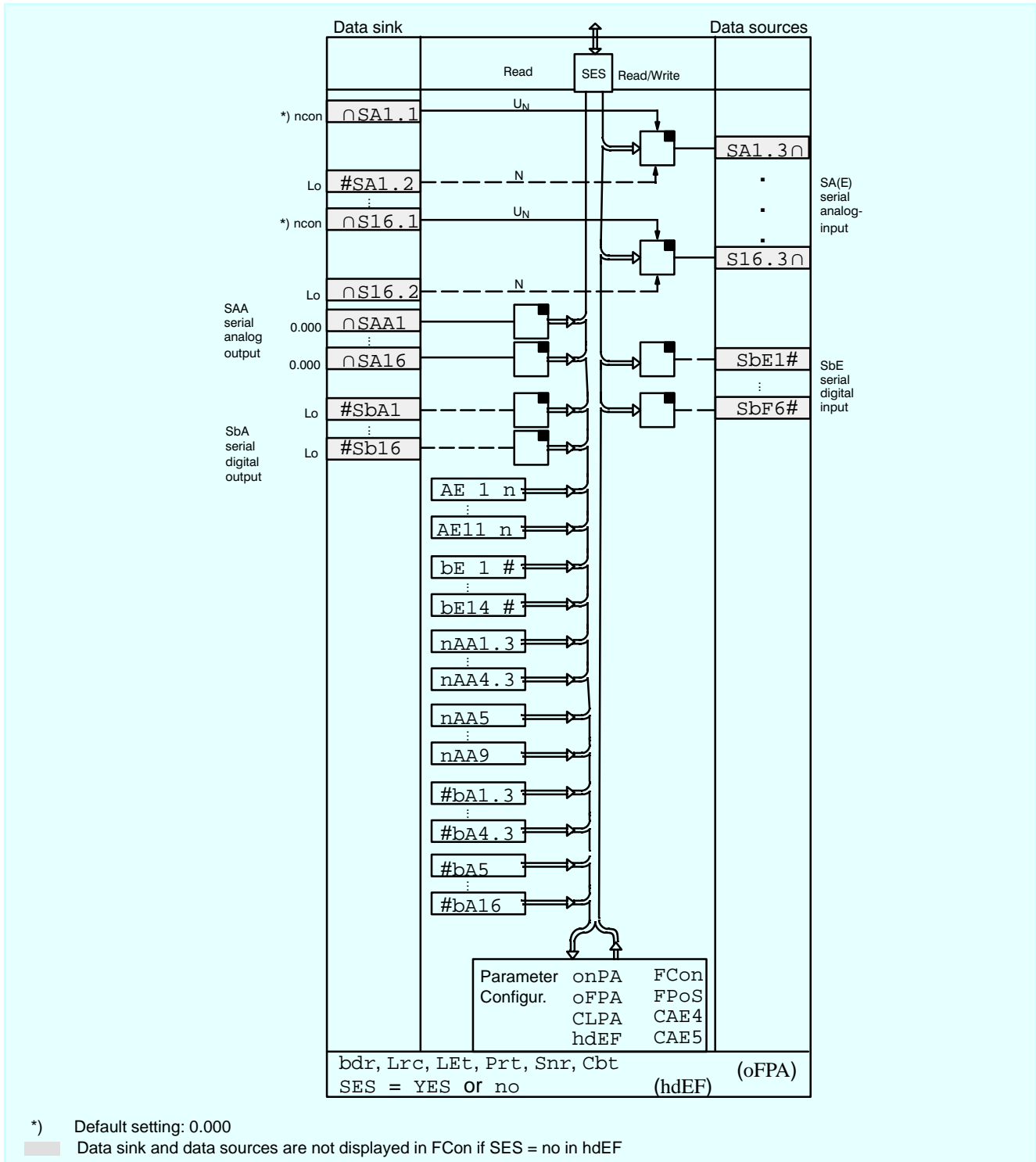

Technical data

| Technical data | |
|---|--|
| General data | |
| Mounting position | Any |
| Climatic classes | |
| - Storage: 1K2 according to DIN IEC 721 Part 3-1 | -25 to +75 °C |
| - Transport: 2K2 according to DIN IEC 721 Part 3-2 | -25 to +75 °C |
| - Operation: 3K3 according to DIN IEC 721 Part 3-3 | 0 to +50 °C |
| Degree of protection to EN 60 529 | |
| Front module | IP 64 |
| Housing | IP 30 |
| Connections | IP 20 |
| Controller design | |
| - To EN 61 010 Part 1, March 1994 - Protection class/to IEC 536 - Mains connection isolated from field signals by protective screen to DIN/VDE 0106 Part 101 (Nov. 86) (IEC 536) - Outputs are small function voltages to DIN/VDE 0100 Part 410 (Nov. 83) - Clearance and creepage paths for overvoltage class III and contamination class 2 to DIN VDE 0110 Part 1 (January 1989), unless stated otherwise. | |
| The following approval and identification are available for the SIPART DR24 controller: | |
| <ul style="list-style-type: none"> CE marking Compliance with the following harmonized European standards: <ul style="list-style-type: none"> EC conformity declaration No. DR22/24-2/98, EMC guidelines 89/336 EEC Emitted interference <ul style="list-style-type: none"> DIN EN 50 081 Part 2, issue: 3/1994 Noise immunity <ul style="list-style-type: none"> DIN EN 50 082 Part 2, issue: 3/1995 NS guidelines 73/23 EEC EN 61 010 Part 1, issue: 3/1993 EN 60 529, issue 6/1991 | |
| Weight, standard device without options | Approx. 1.2 kg |
| Colour | |
| Front module frame | RAL 7037 |
| Front surface | RAL 7035 |
| Material | |
| Housing and front frame | Polycarbonate, reinforced with fiber glass |
| Front foil | Polyester |
| Power supply connection | |
| AC 115/230 V | 3-pin earthed plug IEC 320/V |
| AC/DC 24 V | Special 2-pin plug |
| Process signal connections | Multiple screw terminal blocks, cannot be confused when connecting, for conductor cross-section 1.5 mm ² (AWG 14) |
| Protective earth connection | Earth screw |
| A rail can be mounted on the rear panel of the power supply. The rail is included in the delivery of the coupling relay mode. | |

| Power supply | | | |
|--|-----------------|----------------|-----------------------------|
| Rated voltage | Switchable | | AC/DC 24 V |
| | AC 230 V | AC 115 V | |
| Operating voltage range | AC 187 to 276 V | AC 93 to 138 V | DC 20 to 35 V ⁴⁾ |
| Frequency range | 48 to 63 Hz | | - |
| Peak voltages not periodic to VDE 160 | | | |
| 1.3 ms | ≤ 780 V | ≤ 390 V | ≤ 70 V |
| 10 μs | ≤ 1500 V | ≤ 1500 V | ≤ 500 V |
| External current I_{ext} ⁵⁾ | 450 mA | | |
| Power consumption | | | |
| Active power/ apparent power ⁶⁾ | | | |
| Stand. contr. | | | |
| - without options, without I_{Ext} | 8 W/17 VA | 8 W/13 VA | 8 W/11 VA |
| - with options, without I_{Ext} | 13 W/25 VA | 13 W/20 VA | 13 W/18 VA |
| - with options, with I_{Ext} | 26 W/45 VA | 26 W/36 VA | 28 W/35 VA |

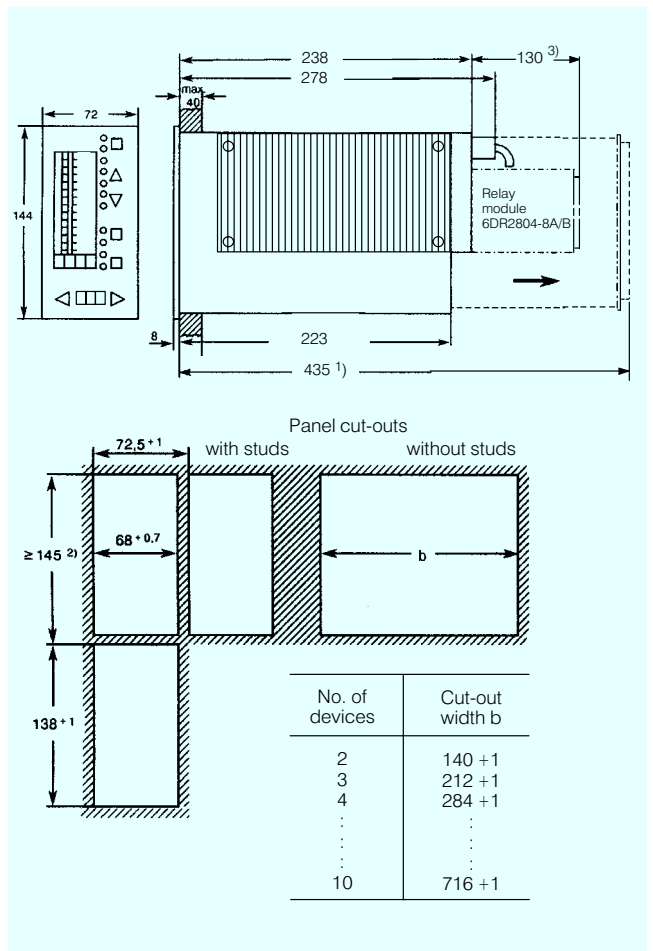

Fig. 7/7 SIPART DR24 multi-function unit and panel cut-outs, dimensions

- 1) Space required for removal of main circuit board.
- 2) Observe permitted ambient temperature when stacking without intermediate spacing.
- 3) A relay module containing 2 or 4 relay contacts (6DR2804-8A/-8B) can be snapped onto the rear of the multi-function unit, in which case the mounting depth increases by 130 mm.
- 4) Includes harmonic content.
- 5) Derived from L+, BA and AA.
- 6) Capacitive.

SIPART DR24 Multi-function Unit

6DR2410-

Technical data

| Technical data (continued) | | | | |
|---|------------------------------------|---------|----------------------------------|---------|
| Power supply (continued) | | | | |
| Permitted voltage dips ¹⁾ Stand. contr. - without options, without I _{Ext} | ≤ 90 ms | ≤ 70 ms | ≤ 55 ms | ≤ 30 ms |
| - with options, without I _{Ext} | ≤ 80 ms | ≤ 60 ms | ≤ 50 ms | ≤ 25 ms |
| - with options, with I _{Ext} | ≤ 50 ms | ≤ 35 ms | ≤ 35 ms | ≤ 20 ms |
| Test voltages (1 min) - primary - secondary - primary - prot. cond. - secondary - prot. cond. | AC 1.5 kV AC 1.5 kV DC 700 V | | AC 500 V AC 500 V DC 700 V | |
| Inputs and outputs, display technology | | | | |
| <ul style="list-style-type: none"> Analog inputs AE1, AE2, AE3 and AE6 to AE11 (input module 6DR2800-8A) | | | | |
| Input signal range | 0/199.6 to 998 mV or 0/2 to 10 V | | | |
| Voltage | 0/4 to 20 mA | | | |
| Current | | | | |
| Input impedance | 200 kΩ | | | |
| Differential (voltage) | 49.9 Ω ± 0.1 % | | | |
| Differential (current) | > 500 kΩ | | | |
| Common-mode | 0 to 10 V | | | |
| Common-mode voltage | 50 ms | | | |
| Filter time constant | 0.05 %/10 K | | | |
| Effect of temperature | 0.1 %/10 K | | | |
| Zero | | | | |
| Gain | | | | |
| <ul style="list-style-type: none"> Analog outputs AA1 to AA3 | | | | |
| Rated signal range | 0/4 to 20 mA | | | |
| Operating range | 0 to 20.5 mA or 3.6 to 20.5 mA | | | |
| Load voltage | -1 to +18 V | | | |
| Max. inductive load | ≤ 0.1 H | | | |
| No-load voltage | ≤ 26 V | | | |
| Time constant | 300 ms | | | |
| Residual ripple 900 Hz | ≤ 0.2 % | | | |
| Resolution | ≤ 0.1 % | | | |
| Zero error | ≤ 0.3 % of measuring span | | | |
| Gain error | ≤ 0.3 % of measuring span | | | |
| Linearity error | ≤ 0.05 % of measuring span | | | |
| Load dependence | ≤ 0.1 % | | | |
| Effect of temperature | ≤ 0.1 %/10 K | | | |
| Zero | ≤ 0.1 %/10 K | | | |
| Gain | | | | |
| <ul style="list-style-type: none"> Transmitter supply L+ | | | | |
| Rated voltage | 20 to 26 V | | | |
| On-load current | ≤ 100 mA, short-circuit proof | | | |
| Short-circuit current | ≤ 200 mA pulsed | | | |
| <ul style="list-style-type: none"> Digital inputs BE1 to BE4 | | | | |
| Signal status 0 | ≤ 4.5 V or open | | | |
| Signal status 1 | ≥ 13 V | | | |
| Static destruction limit | ± 35 V | | | |
| Input impedance | ≥ 27 kΩ | | | |
| <ul style="list-style-type: none"> Digital outputs BA1 to BA8 (connected via Wired-OR diodes) | | | | |
| Signal status 0 | ≤ 1.5 V | | | |
| Signal status 1 | 19 to 26 V | | | |
| On-load current | ≤ 50 mA | | | |
| Short-circuit current | ≤ 80 mA pulsed | | | |
| <ul style="list-style-type: none"> Cycle time | | | | |
| | > 60 ms, user program dependent | | | |

| | |
|--|--|
| <ul style="list-style-type: none"> A/D conversion | |
| Method | Successive approximation with > 120 measurements per input and averaging over 20 or 16.67 ms |
| Resolution | 11 bit ± 0.06 % |
| Zero error | ≤ 0.2 % of the measuring span |
| Gain error | ≤ 0.2 % of the measuring span |
| Linearity error | ≤ 0.2 % of the measuring span |
| Effect of temperature | |
| Zero | ≤ 0.05 %/10 K |
| Gain | ≤ 0.1 %/10 K |
| <ul style="list-style-type: none"> Parameters | |
| Adjusting Rate | tA 2/3 (more-less) |
| Precision | |
| Time parameters | ≤ ± 0.05 % throughout the complete temperature range |
| All others | Absolute, depending on resolution |
| <ul style="list-style-type: none"> Display technology | |
| Digital dd1, dd2 displays | 4½ digit, 7-segment LEDs |
| Colour dd1 | Green |
| dd2 | Red |
| Digit height | 7 mm |
| Display range | Adjustable start-full scale |
| Numeric range | -1999 to 19999 |
| Decimal point | Variable |
| Refresh rate | 1 to 100 cycles/display |
| Resolution | 1 digit, but not better than A/D converter |
| Display error | Corresponding to A/D converter and analog inputs |
| Digital dd3 display | 3-digit, 7-segment LEDs |
| Colour | Yellow |
| Digit height | 7 mm |
| Display range | Adjustable start-full scale |
| Numeric range | -199 to 999 |
| Decimal point | Variable |
| Refresh rate | 1 to 100 cycle/display, variable |
| Resolution | 1 digit, but not better than A/D converter |
| Display error | Corresponding to A/D converter and analog inputs |
| <ul style="list-style-type: none"> Analog dA1, dA2 displays | |
| Colour dA1 | Red |
| dA2 | Green |
| Display range | LED array with 30 LEDs |
| Signal range | -199.9 to 199.9 %, variable |
| Overflow | < -0.85 % of display range; 1st LED flashes |
| | > 100.85 % of display range; 30th LED flashes |
| Resolution | 1.7 % by alternate lighting of 1 or 2 LEDs, the centre point of the illuminated LEDs acting as a pointer |
| Refresh rate | Cyclic |

¹⁾ Load voltage of analog outputs thereby reduced to 13 V, L+ reduced to + 15 V and voltage on digital outputs drops to + 14 V.

Ordering data

| Ordering data | Order No. |
|---|---|
| SIPART DR24 multi-function unit 72 x 144, basic unit with - 3 analog inputs - 3 analog outputs - 4 digital inputs - 8 digital outputs - user program memory • for AC/DC 24 V power supply • for switchable AC 230/115 V supply | 6DR2410-4 6DR2410-5 |
| Input/output modules Analog signal module - for current input 0/4 to 20 mA or voltage inputs 0/0.2 to 1 V or 0/2 to 10 V (6DR2800-8J) - for resistance based sensor (R module) (6DR2800-8R) - for TC/RTD/R/mV signals, programmable (UNI module) (6DR2800-8V) - Reference junction terminal for TC, internal (to be used in conjunction with UNI module (6DR2805-8A) - Measuring range connector for $I = 20$ mA and $U = 10$ V (to be used in conjunction with UNI module) (6DR2805-8J) - with 3 analog outputs 0/4 to 20 mA and 3 binary inputs (6DR2802-8B) - with 3 analog inputs 0/4 to 20 mA or 0/0.2 to 1 V or 0/2 to 10 V (6DR2800-8A) - y-hold module (6DR2802-8A) Switching signal module - with 5 digital inputs (6DR2801-8C) - with 4 digital outputs and two digital inputs (6DR2801-8E) - with 2 relay outputs (6DR2801-8D) Coupling relay module - With 4 relays (AC 250 V) (6DR2804-8A) - With 2 relays (AC 250 V) (6DR2804-8B) Interface modules - For serial communications via RS 232 or RS 485 (6DR2803-8C) - PROFIBUS-DP module (6DR2803-8P) | See Catalog MP 31, Section 8 See Page 7/21 |
| Documentation SIPART DR24 multi-function unit manual - German - English Mounting and installation instructions, German/English Operating Instructions "SIPART DR24 Serial Interface" - German - English | C79000-G7400-C153 C79000-G7476-C153 C79000-M7474-C38 on request on request |

Scope of supply

The scope of supply of a DR24 multi-function unit includes:

- 1 multi-function unit as ordered
- 1 power supply connector 115/230 V or a special connector for 24 V AC/DC supply
- 2 clamping elements, pluggable
- 1 mounting and installation instructions (German/English)

Available ex-stores

Items marked ■ are available ex-stores.

Input/output modules and accessories

The input/output modules are described in Catalog MP 31, Section 8; Exception: 6DR2802-8B, see page 7/21.

Section 9 of the catalog contains details about software for parameterizing the multi-function unit from a PC, interfacing to systems and the necessary accessories (connectors, line drivers, etc.).

Training

Refer to ITC (German) catalog for details of training courses for the controllers.

Note:

When using the SIPROM DR24 program "old", only the scope of functions of the previous SIPART DR24 controller can be utilized with the innovated SIPART DR24 controller "new" (6DR2410-...).

The additional functions can only be utilized with direct programming on the front panel of the controller until SIPROM DR24 "new" is available.

It is currently envisaged that the revised, extended SIPROM DR24 program "new" will be available in May 1999.

SIPART DR24 Input/Output Modules

6DR2410-

Overview: applications

| Analog signal modules | SIPART DR24 | | | | | Description see Catalog MP31, Page |
|---|-------------|--------|--------|--------------------|-----------------------|--|
| | Slot 2 | Slot 3 | Slot 4 | Slot 5 | Slot 6 | |
| U/I module 6DR2800-8J | AI4 | AI5 | - | - | - | 8/3 |
| 3 x U/I module 6DR2800-8A | - | - | - | AI9/10/11 | AI6/7/8 | 8/4 |
| R module 6DR2800-8R | AI4 | AI5 | - | - | - | 8/5 |
| Pt 100 module 6DR2800-8P | (AI4)* | (AI5)* | - | - | - | 8/6 |
| TC module 6DR2800-8T | (AI4)* | (AI5)* | - | - | - | 8/7 |
| UNI module 6DR2800-8V (TC/RTD/R/U/I) | AI4 | AI5 | - | - | - | 8/8 |
| γ-hold module 6DR2802-8A | - | - | - | AO7 | AO4 | 8/10 |
| 3AO/3DI module 6DR2802-8B | - | - | - | AO7/8/9 DI5/6/7 | AO4/5/6 DI10/11/12 | Supplement Jan. 1999, 7/21 |

NEW

*) Use the UNI module 6DR2800-8V.

| Switching signal modules | SIPART DR24 | | | | | Description see Catalog MP31, Page |
|--------------------------|-------------|--------|--------|-----------------------|------------------------------|--|
| | Slot 2 | Slot 3 | Slot 4 | Slot 5 | Slot 6 | |
| 5 DI 6DR2801-8C | - | - | - | DI5/6/7/8/9 | DI 10/11/12/13/14 | 8/11 |
| 2 relays 6DR2801-8D | - | - | - | DO9/10 | DO13/14 | 8/12 |
| 4DO/2DI 6DR2801-8E | - | - | - | DO9/10/11/12 DI5/6 | DO13/14/15/1 6 DI10/11 | 8/13 |

| Interface module | SIPART DR24 | | | | | Description see Catalog MP31, Page |
|-------------------------------|-------------|--------|--------|--------|--------|--|
| | Slot 2 | Slot 3 | Slot 4 | Slot 5 | Slot 6 | |
| SES module 6DR2803-8C | - | - | - | - | - | 8/14 |
| RS 232/SIPART bus | - | - | Yes | - | - | |
| RS 485 | - | - | Yes | - | - | |
| PROFIBUS-DP module 6DR2803-8P | - | - | Yes | - | - | 8/15 |

NEW

| Coupling relay module can be installed on rear: | SIPART DR24 | Description see Catalog MP 31, Page |
|--|-------------|---|
| with 4 relays 6DR2804-8A | Yes | 8/16 |
| with 2 relays 6DR2804-8B | Yes | 8/16 |

| Depending on the application, the following can be used in conjunction with the UNI module 6DR2800-8V: | Description see Catalog MP 31, Page |
|--|---|
| Reference junction terminal 6DR2805-8A | 8/8 |
| Measuring range connector 6DR2805-8J | 8/8 |

Module 3AO/3DI

- 3AO/3DI module 6DR2802-8B for extension of analog outputs and binary inputs

The 3AO/3DI-module is suitable for use in the SIPART DR24 controllers.

Assignment of functions and the logic is performed using the configuring switches.

The screw-type terminal is supplied with the module

Technical data 6DR2802-8B

3AO/3DI module

| | |
|---------------------------------|--------------------------------|
| Analog outputs | |
| Rated signal range (0 to 100 %) | 0 to 20 mA or 4 to 20 mA |
| Output range | 0 to 20,5 mA or 3,8 to 20,5 mA |
| Load voltage | -1 V to 18 V |
| No load voltage | ≤ 26 V |
| Inductive load | ≤ 0,1 H |
| Time constant | 10 ms |
| Residual ripple 900 Hz | ≤ 0,2 % |
| Resolution | 10 Bit |
| Load dependence | ≤ 0,1 % |
| Zero error | ≤ 0,3 % |
| Gain error | ≤ 0,3 % |
| Linearity error | ≤ 0,05 % |

| | |
|---|-----------------|
| Digital inputs | |
| Signal status "0" | ≤ 4,5 V or open |
| Signal status "1" | ≥ 13 V |
| Input resistance | ≥ 27 kΩ |
| Static destruction limit across in-puts | ± 35 V |

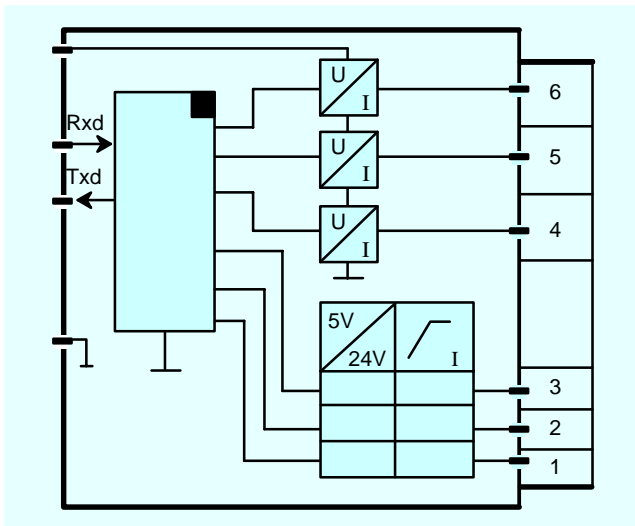

Fig. 7/8 Wiring of 3AO/3DI module

Assignment of the terminals to the analog output (AO) and the digital input (DI); depending on slot

| Terminal | SIPART DR24 | |
|----------|----------------|--------|
| | Analog outputs | |
| | Slot 5 | Slot 6 |
| 6 | AO9 | AO6 |
| 5 | AO8 | AO5 |
| 4 | AO7 | AO4 |
| Terminal | Digital inputs | |
| | Slot 5 | Slot 6 |
| | 3 | DI7 |
| 2 | DI6 | DI11 |
| 1 | DI5 | DI10 |

Ordering data

| | |
|--|-------------------|
| | Order No. |
| Analog signal module 3AO/3DI module to extend the analog outputs and digital inputs | 6DR2802-8B |

Available ex-stores

Conditions of Sale and Delivery

Subject to the General Conditions of Supply and Delivery for Products and Services of the Electrical and Electronics Industry and to any other conditions agreed upon with the recipients of catalogs.

The technical data, dimensions and weights are subject to change unless otherwise stated on the individual pages of this catalog.

The illustrations are for reference only.

The General Conditions for Software Products for Automation shall apply to software products.

Export

The products listed in this catalog may be subject to European, German or U.S. export regulations.

Any export under restriction requires approval by responsible authorities.

Information thereon can be obtained from our acknowledgements, delivery notes and invoices. ■

A&D/MP/e En 7.96

Year 2000 compatibility

The change of the year 2000 affects not only data processing systems but also products, systems and plants using automation and drives technology.



Apart from hardware and software components, user programs which process calendar dates are especially affected by this change to the year 2000.

We at Siemens in the Automation and Drives Group have set this topic of year 2000 compatibility as a high priority in order to provide our customers with as smooth a transfer as possible into the next millenium.

The behavior of our products is being given a detailed examination employing the test profiles of the British Standards Institution (BSI), which have met with international acceptance. The results of this examination can be found in our "Year 2000" database in the Internet under:

<http://www.ad.siemens.de/jahr2000>

Combinations of products and systems in plants as well as individual adaptations and/or expansions of product and system constellations can result in errors or faults in of individual product or system functioning and/or of the entire plant with the change to the year 2000.

Should you have any questions contact your local Siemens representative.