

rotork[®]
Gears

Nuclear Gearboxes



rotork[®] Nuclear



Actuation Solutions for Nuclear Powerplants

Redefining Flow Control

Contents

Section	Page	Section	Page
1 Introduction	4	5 Specific Qualification of Manufactured Gearboxes	8
1.1 Design qualification basis		5.1 Quality assurance programme for nuclear gearboxes	
1.2 Quality assurance		5.2 Procurement of commercial grade components for safety related application	
1.3 Non-safety related gearboxes		5.3 Lot control and material traceability of safety related components	
2 Design Specification	5	6 Rotork Gears Nuclear Safety Related Gearboxes	9
2.1 Mounting Details		6.1 IWN quarter-turn worm gearboxes	
2.2 Design life		6.2 IBN multi-turn bevel gearboxes	
2.3 Design environment		6.3 ISN multi-turn spur gearboxes	
3 Design Qualification	6	7 Documentation	11
3.1 Qualification basis		8 Maintenance of Qualified Gearboxes	11
3.1.1 Type IWN, ISN, IBN gearboxes		9 Ordering Information	11
3.1.1.1 Qualification tests			
3.1.1.2 IWN, ISN, IBN qualification test parameters			
3.1.1.3 Additional IWN qualification test parameters			
4 Mechanical Construction	8		

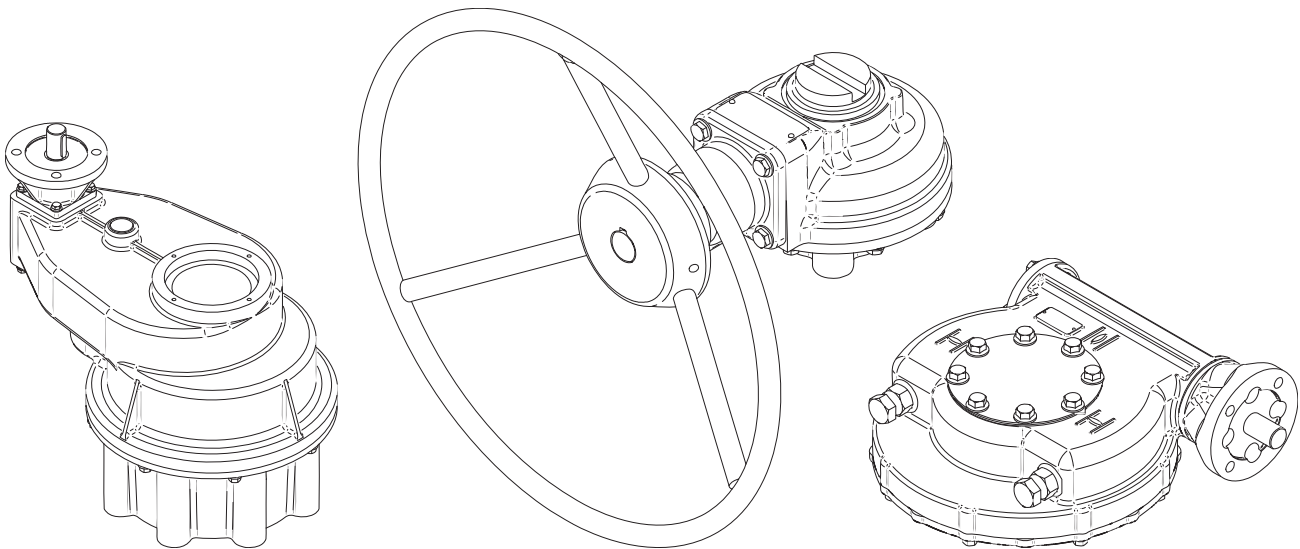

rotork® Gears

Rotork is the global market leader in valve automation and flow control. We provide a comprehensive range of valve actuators, controls and associated equipment, as well as a variety of valve actuator services including commissioning, preventive maintenance and retrofit solutions. Rotork Gears specialises in the design, production and support of gear operators and valvekits. We are committed to providing the marketplace with the latest technology, consistent high quality, innovative designs, outstanding reliability and superior performance.

Rotork Gears works directly with both valve and actuator manufacturers and distributors worldwide. We design, assemble and supply complete gearbox assemblies, as well as a wide range of switchboxes, valve position monitors, extensions, locking devices and other adaptation accessories for customised valve configuration.

As a division within the Rotork Group, we offer all the advantages of big company support and back-up, while remaining firmly focused on the virtues of close customer contact and genuine personal service.

Rotork. Redefining flow control.



rotork®
Controls

rotork®
Instruments

rotork®
Fluid Systems

rotork®
Site Services

1 Introduction

Electric motor and manually operated valves feature prominently in the centralized control systems of nuclear power generating stations and make a major contribution to the economy, efficiency, reliability and safety of the station in which they operate. The emphasis on safety has raised the level of technology required for a wide range of equipment associated with these systems.

Rotork has been a participant member of the sub-committees of the US Standards Committee responsible for drafting various standards including IEEE 382 since the 1970s.

Generally the categories of safety related duty valve applications are as designated as Class 1E in standard IEEE 323 and defined as equipment and systems that are essential to emergency reactor shutdown, containment isolation, reactor core cooling and containment and reactor heat removal, or otherwise essential in preventing significant release of radioactive material to the environment:

- a** Inside containment - active
- b** Inside containment - passive
- c** Outside containment - active
- d** Outside containment - passive

Where 'active' refers to valves which have to operate during and after reactor emergency and 'passive' refers to valves which do not have to operate but must maintain their structural integrity during and immediately after an emergency. Conditions associated with the outside containment valve are far less severe than for the inside containment active units.

IWN, IBN and ISN gearboxes have been qualified for safety related duties in nuclear power plants, and are manufactured under strict quality control conditions which ensure that:

The design standard qualified generically by type test is maintained during manufacture, and the specific requirements of the application are met.

1.1 Design qualification basis

The basis of qualification of Rotork gearboxes is the IEEE 382 – 1996 – “IEEE Standard for the Qualification of Actuators for Power-Operated Valves Assemblies with Safety-Related Functions for Nuclear Power Plants” which specifies procedures and test methods for the environmental qualification of valve actuators.

The levels of qualification for the gearboxes are given in Section 3.

1.2 Quality assurance

All Rotork nuclear gearboxes are manufactured to a quality assurance programme which meets the requirements of the relevant sections of the following standards:

- 10 CFR 50 Appendix B
- ASME NQA-1
- CSA Z299.1
- ISO 9000-2008

1.3 Non-safety related gearboxes

Where valves are not designated as safety related, normally standard Rotork gearboxes remain the most obvious choice for installed economy and reliability.

2 Design Specification

These specification notes refer to those features which are special for nuclear duty or important for other reasons. While these design qualifications are based on conditions postulated for pressure containments of PWR and BWR plants, their use can be extended to other reactor designs wherein normal and abnormal conditions fall within the limits specified.

2.1 Mounting Details

All Rotork nuclear gearboxes are supplied with standard input (for actuation purposes) and output flanges to the standards given below:

ISO5210	-	Multi-turn (IBN, ISN Gearboxes)
ISO5211	-	Part-turn (IWN Gearbox)
MSS SP-101	-	Part-turn (IWN Gearbox)
MSS SP-102	-	Multi-turn (IBN, ISN Gearboxes)

Rotork gearboxes can be assembled to Rotork nuclear qualified actuators and have the designations IWN for quarter-turn gearboxes, IBN for bevel gearboxes and ISN for spur gearboxes.

2.2 Design life

The gearboxes are designed for a working life of 40 years based on the following total number of operating cycles:

IWN gearboxes	-	4000
IBN, ISN gearboxes	-	2000

An operating cycle is defined as moving the valve from the open position to the close position and back to the open position. The gearbox is set to torque operation in the close position and limit operation in the open position. The torque setting at the close position is actuator rated (maximum) torque. During travel, an average load of 33% of the rated torque is applied.

2.3 Design environment

Normal conditions

All nuclear gearboxes are capable of operation for 15 minutes in any one hour (unless otherwise specified) at average valve load under the following conditions:

Ambient pressure	8 psig to 18 psig
Humidity	100% RH
Temperature	60 °C (148 °F)
Standard radiation life accumulated dose with no change of components	70.00E+04 Gy 70.00E+06 Rad
Plant induced vibration	0.75g all frequencies

Accident conditions

Rotork nuclear gearboxes are capable of a minimum of 20 operations during and following exposure to the following conditions (see LOCA temperature and pressure - time test profiles in Qualification Test Summary).

Gearbox Type	IWN	IBN	ISN
Ambient Pressure (maximum)	87 psig, 6.0 barg		
Ambient Temperature (maximum)	188 °C (370 °F)		
Atmosphere: Saturated air and steam mixture with chemical spray consisting of (typically) 0.28 molar H ₃ BO ₃ (6,200 ppm boron), 0.064 molar N ₂ S ₂ O ₃ , and NaOH to make a pH of 10.5 at 25 °C (77 °F) (about 0.59%).	Yes		
Seismic acceleration	8g	6g	6.5g
Seismic frequency range	0.2-34 Hz		
Radiation life accumulated dose	200.00E+04 Gy 200.00E+06 Rad		

3 Design Qualification

The object of nuclear environmental qualification is to provide auditable evidence that the gearboxes are capable of meeting their performance specifications under normal environments and under those conditions experienced during a Design Basis Event (DBE).

3.1 Qualification basis

3.1.1 Type IWN, IBN, ISN gearboxes

3.1.1.1 Qualification tests

Rotork nuclear specification gearboxes have been environmentally qualified in accordance with IEEE-Std-382. The basis of this qualification is a series of comprehensive tests conducted by Wyle Laboratories, Nuclear Logistics Inc, Trentec Inc USA and Kinectrics, Canada.

The applicable qualification test reports are: -

Laboratory	Report number
Nuclear Logistics Inc, Dallas, USA	QR-029001-7
	QR-029001-2
Thermodyne Laboratories Inc, Toronto, Canada	01R-2-2-3
	01R-2-2-4
	01R-2-2-5
Qualtech NP (since 2010)/Trentec Inc (prior 2010); Cincinnati, USA	OQ020.0
	Q9005.0
	9T065.0
	OQ007.0
	OQ018.0
	2Q002.0
	2Q005.0
	Q0044

3.1.1.2 IWN, IBN & ISN qualification test parameters

a) Normal Radiation aging - 70.00E+04 Gy (70.00E+06 Rad).

b) Mechanical wear aging - 4000 cycles for IWN, 2000 cycles for IBN and ISN.

c) Thermal Aging (Parameters derived using Arrhenius Law 125 °C (257 °F) for 16 days).

d) Pressurisation aging - 15 cycles of 3-minute duration at 65 psig.

e) Resonant search - A low-level (0.2g) resonant search from 1 to 100 Hz and at one octave per minute.

f) Plant induced vibration aging - Biaxial sinusoidal motion of 0.75g with a frequency of 5 to 100 to 5 Hz at a rate of two octaves per minute. Ninety minutes of vibration in each orthogonal axis.

g) Seismic - RMF test - A random multifrequency test with a 30-second duration simultaneous horizontal and vertical phase - incoherent inputs of random motion consisting of frequency band widths spaced one-third octave apart over the frequency range of 1 Hz to 100 Hz as necessary to envelope the required response spectra (see Figure 3.1). Five OBE level tests (two-thirds of SSE level) and one SSE level test in each orientation.

h) DBE Radiation - 130.00E+04 Gy (130.00E+06 Rad).

i) DBE Environmental test - A steam exposure profile (see Figure 3.2) for a LOCA simulation representing PWR and BWR in-containment service.

j) Seismic - RIM test - Two OBE tests with a sinusoidal sweep from 2 to 35 to 2 Hz in each axis at a rate of one octave per minute and a level of two-thirds of the required input motion. One SSE in each axis consisting of a continuous series of single frequency sine beat tests at the one-third octave interval test frequencies and test levels indicated in IEEE 382 1996 (see Figure 3.3).

3.1.1.3 Additional IWN qualification test parameters

i) Safety Relief Valve duty aging test - Test specimen was subjected to a minimum of 8400 stress cycles.

ii) Upset and Faulted Loading aging test - A series of multi-frequency tests upset followed by faulted tests of 30 second duration in accordance with IEEE-std-344. 20 upset seismic fatigue test runs were performed followed by 4 faulted test runs. In all more than 5 stress cycles were carried out.

Note: No significant change was found in the results of the baseline function. Tests were performed after each portion of the type test.

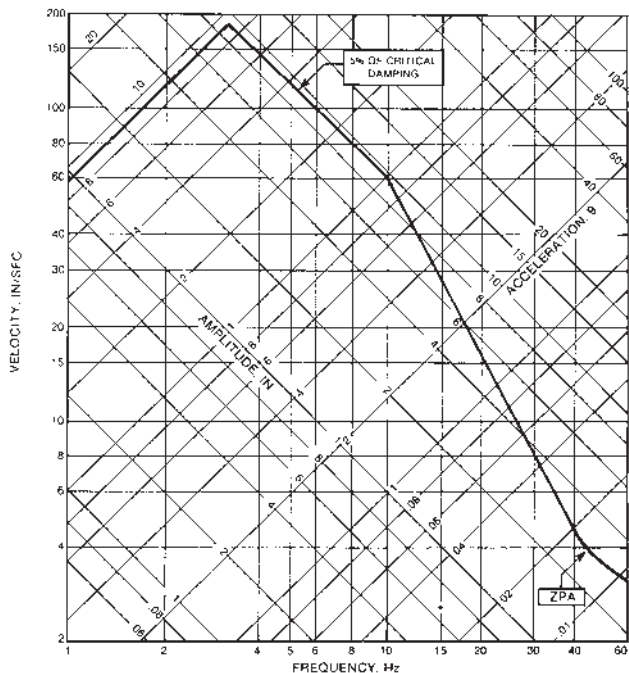

Fig. 3.1 Seismic qualification, required response spectrum (IEEE 382 1996).

3 Design Qualification

IWN gearboxes and actuator assemblies have been subjected to full environmental qualification testing. The IBN and ISN gearboxes and actuator assemblies have been seismically tested.

The IBN and ISN gearboxes contain identical non-metallic materials as the IWN gearboxes and are therefore environmentally qualified by similarity analysis.

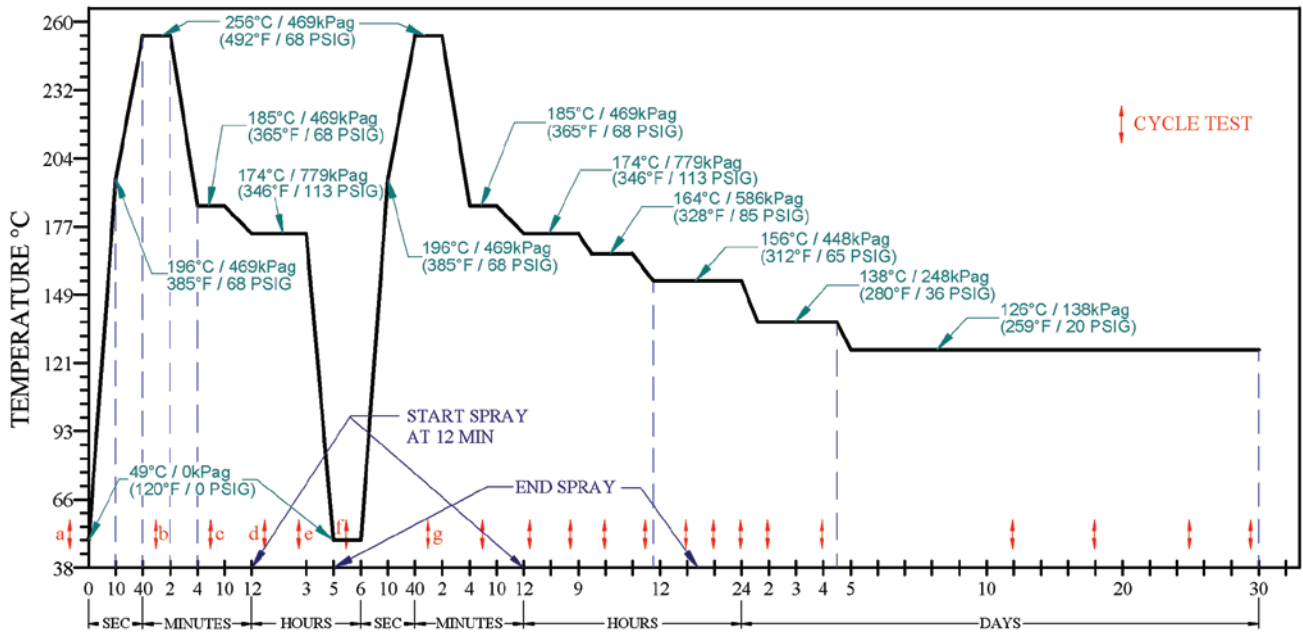

Fig. 3.2 Environmental qualification parameters.

The qualification testing conducted on type NA1E actuators and IWN, IBN & ISN gearboxes provides the basis for the highest level of confidence because of the following features:

- a) Representative test specimens of the actuator and gearbox generic groups were selected using the 'Method of Selection of Representative Actuators for Type Testing' outlined in Annex A of IEEE-Std-382.
 - b) The environmental qualification tests were performed by independent 10CFR50 Appendix B accredited laboratories.
 - c) Live hot steam was used during DBE simulation.
 - d) Actuators and gearboxes were tested.
 - e) The seismic testing performed on the actuator/gearbox combinations resulted in the worst-case conditions for the gearbox due to its centre of gravity being further from the test rig mounting flange.
 - f) A separate main steam line break simulation was performed after the DBE test had been completed.
 - g) Baseline functional testing was performed after each phase of the test programme verifying that the gearbox performed as it did during the receipt inspection.
- Furthermore, as part of the test programme the NA1E and IWN assembly also completed:
- h) Safety Relief Valve tests were conducted at 8g ZPA in addition to the seismic test requirements of IEEE-Std-382.
 - i) Upset and Faulted loading tests were conducted at 8g ZPA in addition to the seismic test requirements of IEEE-Std-382.
 - j) Hydrodynamic Chugging tests were conducted at 8g ZPA in addition to the seismic test requirements of IEEE-Std-382.

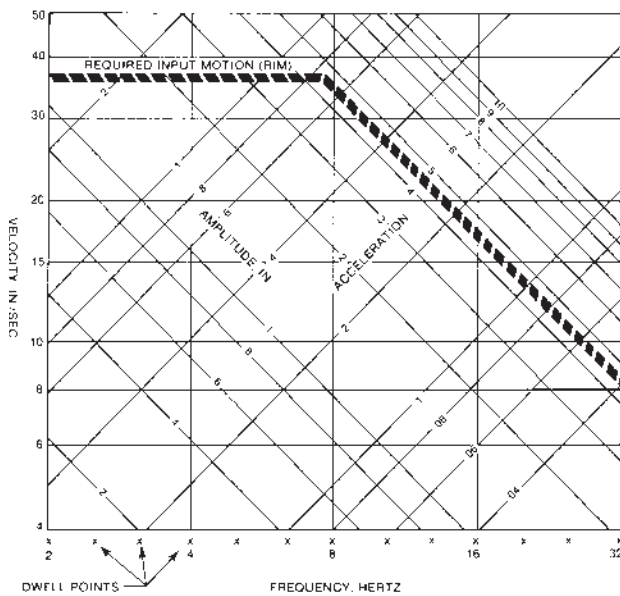

Fig. 3.3 Seismic qualification Required Input Motion (IEEE 382 1996).

4 Mechanical Construction

IWN, ISN and IBN gearboxes have SG Iron castings (for main housings, baseplate and actuator mounting flange), Viton O-Rings and the gearcase is grease filled and suitable for operation with the valve at any mounting orientation.

Table 1 — Nuclear product material specification

Component	
Gearcase	SG Iron
Input flange/housing	SG Iron
Baseplate	SG Iron
O-ring	Viton
Paint system	PE3 primer - for transit protection, Qualified paint system to be applied by customer
	Carboline Carboguard 890N
Lubricant	Grease
Drive bush	Aluminium bronze or steel

5 Specific Qualification of Manufactured Gearboxes

Design qualification shows that the generic design basis is suitable for the intended purpose, exemplified by type tests of particular units. Rotork Gears quality systems ensure that each gearbox is manufactured to the qualification design standard.

- a) The gearboxes are sized and chosen to meet the specific application.
- b) The components used in the manufacture have traceable and auditable links to the qualified design standard.

5.1 Quality Assurance program for Nuclear Gearboxes

The Rotork Gears quality system details all the procedures and documentation utilised for both standard and nuclear gearboxes. The program for nuclear gearboxes has been evolved in co-operation with utilities and architect-engineers responsible for construction and operation of nuclear power stations.

The Rotork Gears quality assurance program is designed to meet the requirements of 10CFR50 Appendix B, ASME NQA-1 and CSA 2299.1 to ensure that:

- 1 Nuclear safety related components are only supplied by vendors whose own quality systems and performance are under the surveillance of and approved by the Rotork Gears quality manager.
- 2 Nuclear safety related components are manufactured from certified materials.
- 3 Design qualification is maintained during manufacture and unqualified modification is forbidden.
- 4 Specific application requirements and sizing data for each gearbox are recorded.

- 5 Assembly of each nuclear gearbox is carried out under specific procedures and the work is traceable.
- 6 Nuclear safety related components are traceable through the supply chain and to installed gearboxes.
- 7 A certificate of compliance is signed by the quality manager or designee only when he has auditable evidence that all these requirements have been satisfied.

5.2 Procurement of commercial grade components for safety related application

When possible, Rotork Gears purchases safety related components from suppliers audited and approved to a delineated version of 10CFR50 Appendix B quality systems. Where this is not possible, Rotork Gears purchases commercial grade items to the guidelines specified in Electric Power Research Institute (EPRI) document NP-5652 – ‘Guidelines for the Utilisation of Commercial Grade Items in Nuclear Safety Related Applications’.

5.3 Lot control and material traceability of safety related components

All safety related components are lot controlled and are traceable to the gearboxes to which they are fitted.

Records are maintained via the manufacturing system and are available for the life of the plant.

6 Rotork Gears Nuclear Safety Related Gearboxes

Designation of Rotork Gears safety related gearboxes are suffixed with 'N'. The safety related range consists of three gearbox types, the Worm; IWN, Bevel; IBN and Spur; ISN.

6.1 IWN quarter-turn gearboxes

A range of nuclear safety related heavy-duty cast and ductile iron, quarter-turn worm gearboxes. Suited for plug, ball and butterfly valves.

The IWN gearbox range comprises 7 sizes with ratios of 40:1 to 70:1 and a torque range of up to 48,809 Nm (36,000 lbf.ft).

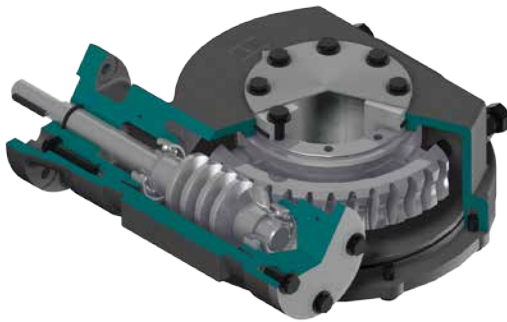

Fig. 6.1 Rotork Gears IWN quarter-turn gearbox

6.2 IBN multi-turn bevel gearboxes

A range of nuclear safety related heavy-duty cast and ductile iron multi-turn bevel gearboxes suited for the most demanding linear valve applications.

The IBN gearbox range comprises 6 sizes with ratios of 2:1 to 8:1 and a torque range up to 8,135 Nm (6,000 lbf.ft) and a thrust range up to 1,320 kN (296,750 lbf).

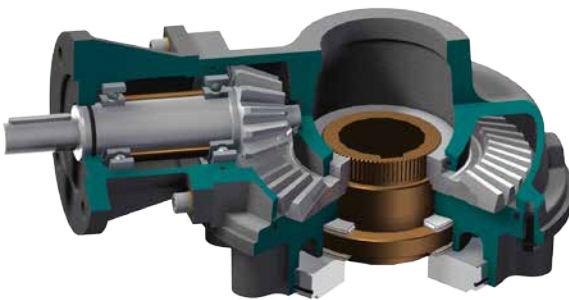

Fig. 6.2 Rotork Gears IBN bevel gearbox

6.3 ISN multi-turn spur gearboxes

A range of nuclear safety related heavy-duty cast and ductile iron multi-turn spur gearboxes suited for the most demanding linear valve applications as an alternative to the IBN gearboxes where higher torque and thrusts and larger stem acceptance is required.

The ISN gearbox range comprises 3 sizes with ratios of 6:1 to 24:1 and a torque range up to 43,386 Nm (32,000 lbf.ft) and a thrust range up to 2,224 kN (500,000 lbf).

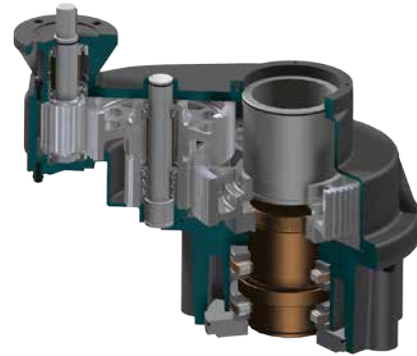

Fig. 6.3 Rotork Gears ISN spur gearbox

6 Rotork Gears Nuclear Safety Related Gearboxes

IWN Worm Quadrant Gearbox Sizing Chart

Gearbox Size	Ratio	⁶ Motor & Manual Output Torque Nm (lbf.ft)	³ Mechanical Advantage	Max Input Torque Motor Nm (lbf.ft)	¹ Input Turns to Close	² Max Hub Bore mm (inch)	Output	Weight kg (lbs)
IWN3	40	1,085 (800)	15	72 (53)	10	45 (1.75)	F/FA10, 12, 14, 16	10.5 (23.1)
IWN3	70	813 (600)	23	35 (26)	18	45 (1.75)	F/FA10, 12, 14, 16	10.5 (23.1)
IWN4	40	2,440 (1,800)	15	163 (120)	10	64 (2.5)	F/FA12, 14, 16	22 (48.5)
IWN4	70	2,034 (1,500)	23	88 (65)	18	64 (2.5)	F/FA12, 14, 16	22 (48.5)
IWN5	40	4,067 (3,000)	17	239 (176)	10	76 (3)	F/FA14, 16, 25	45 (99.1)
IWN5	70	3,390 (2,500)	23	147 (109)	18	76 (3)	F/FA14, 16, 25	45 (99.1)
IWN6	70	8,135 (6,000)	23	354 (261)	18	102 (3.875)	F/FA16, 25, 30	68 (150)
IWN7	60	13,558 (10,000)	25	542 (400)	15	136 (5.25)	F/FA25, 30	120 (264)
IWN8	60	24,404 (18,000)	25	976 (720)	15	157 (6)	F/FA25, 30, 35, 40, 48	180 (396)
IWN9	60	48,809 (36,000)	25	1,952 (1440)	15	178 (6.5)	F/FA30, 35, 40, 48	220 (485)

IBN Range Multi-Turn Bevel Gearbox Sizing Chart

Gearbox Type	Ratio	⁶ Motor & Manual Output Torque Nm (lbf.ft)	Mechanical Advantage	⁴ Thrust kN (lbs)	Stem Acceptance		Minimum except on request	Output Flange	Weight kg (lbs)
					⁵ Key mm (inch)	Screw mm (inch)			
IBN5	2:1	306 (225)	1.70	177 (40,000)	52 (2.04)	55 (2.16)		F/FA14	20 (44)
IBN5	3:1	678 (500)	2.55	177 (40,000)	52 (2.04)	55 (2.16)		F/FA14	20 (44)
IBN5	4:1	678 (500)	3.40	177 (40,000)	52 (2.04)	55 (2.16)		F/FA14	20 (44)
IBN5	6:1	542 (400)	5.10	177 (40,000)	52 (2.04)	55 (2.16)		F/FA14	20 (44)
IBN7	3:1	1,355 (1,000)	2.55	266 (60,000)	65 (2.55)	73 (2.87)		F/FA16	35 (78)
IBN7	4:1	1,355 (1,000)	3.40	266 (60,000)	65 (2.55)	73 (2.87)		F/FA16	35 (78)
IBN7	6:1	1,084 (800)	5.10	266 (60,000)	65 (2.55)	73 (2.87)		F/FA16	35 (78)
IBN9	3:1	2,033 (1,500)	2.55	355 (80,000)	76 (2.99)	86 (3.38)		F/FA25	70 (155)
IBN9	4:1	2,033 (1,500)	3.40	355 (80,000)	76 (2.99)	86 (3.38)		F/FA25	70 (155)
IBN9	6:1	1,627 (1,200)	5.10	355 (80,000)	76 (2.99)	86 (3.38)		F/FA25	70 (155)
IBN11	4:1	4,067 (3,000)	3.40	500 (112,500)	90 (3.54)	100 (3.93)		F/FA30	125 (276)
IBN11	6:1	4,067 (3,000)	5.10	500 (112,500)	90 (3.54)	100 (3.93)		F/FA30	125 (276)
IBN13	6:1	8,135 (6,000)	5.10	834 (187,500)	110 (4.33)	120 (4.72)		F/FA35	200 (441)
IBN13	8:1	8,135 (6,000)	6.80	834 (187,500)	110 (4.33)	120 (4.72)		F/FA35	200 (441)
IBN14	6:1	8,135 (6,000)	5.10	1,320 (296,750)	120 (4.72)	150 (5.90)	65 (2.56)	F/FA40	342 (754)
IBN14	8:1	8,135 (6,000)	6.80	1,320 (296,750)	120 (4.72)	150 (5.90)	65 (2.56)	F/FA40	342 (754)

ISN Range Multi-Turn Spur Gearbox Sizing Chart

Gearbox Type	Ratio	⁶ Motor & Manual Output Torque Nm (lbf.ft)	Mechanical Advantage	⁴ Thrust kN (lbs)	Stem Acceptance		Minimum except on request	Output Flange	Weight kg (lbs)
					⁵ Key mm (inch)	Screw mm (inch)			
ISN16	10:1	16,270 (12,000)	8.870	1,320 (296,750)	120 (4.72)	150 (5.90)	65 (2.56)	F/FA40	400 (896)
ISN16	12:1	16,270 (12,000)	10.800	1,320 (296,750)	120 (4.72)	150 (5.90)	65 (2.56)	F/FA40	400 (896)
ISN16	15:1	16,270 (12,000)	13.500	1,320 (296,750)	120 (4.72)	150 (5.90)	65 (2.56)	F/FA40	400 (896)
ISN19	6:1	40,800 (30,000)	5.500	1,668 (375,000)	170 (6.69)	190 (7.48)	75 (2.95)	F/FA40	810 (1,815)
ISN19	8:1	43,386 (32,000)	7.300	1,668 (375,000)	170 (6.69)	190 (7.48)	75 (2.95)	F/FA40	810 (1,815)
ISN19	10:1	43,386 (32,000)	9.000	1,668 (375,000)	170 (6.69)	190 (7.48)	75 (2.95)	F/FA40	810 (1,815)
ISN19	12:1	43,386 (32,000)	10.820	1,668 (375,000)	170 (6.69)	190 (7.48)	75 (2.95)	F/FA40	810 (1,815)
ISN19	15:1	43,386 (32,000)	13.650	1,668 (375,000)	170 (6.69)	190 (7.48)	75 (2.95)	F/FA40	810 (1,815)
ISN19	24:1	43,386 (32,000)	21.680	1,668 (375,000)	170 (6.69)	190 (7.48)	75 (2.95)	F/FA40	810 (1,815)
ISN20	6:1	40,800 (30,000)	5.500	2,224 (500,000)	200 (7.87)	225 (8.85)	95 (3.74)	POA	980 (2,195)
ISN20	8:1	43,386 (32,000)	7.300	2,224 (500,000)	200 (7.87)	225 (8.85)	95 (3.74)	POA	980 (2,195)
ISN20	10:1	43,386 (32,000)	9.000	2,224 (500,000)	200 (7.87)	225 (8.85)	95 (3.74)	POA	980 (2,195)
ISN20	12:1	43,386 (32,000)	10.820	2,224 (500,000)	200 (7.87)	225 (8.85)	95 (3.74)	POA	980 (2,195)
ISN20	15:1	43,386 (32,000)	13.650	2,224 (500,000)	200 (7.87)	225 (8.85)	95 (3.74)	POA	980 (2,195)
ISN20	24:1	43,386 (32,000)	21.680	2,224 (500,000)	200 (7.87)	225 (8.85)	95 (3.74)	POA	980 (2,195)

- i.e. for 90° at output.
- Max hub bore diameters assume keyway to BS4235. For other keyway sizes please consult Rotork Gears.
- Typical MA for a run-in gearbox. It varies with a number of factors - a normal tolerance of +/-10% can be assumed.
- Keyed stem acceptance assumes keyway to BS4235. For other keyway sizes please consult Rotork Gears.
- The thrusts shown are the maximum loads that are permissible. It is possible that the stall load could be more than twice that of the maximum operating load and this must be accounted for when sizing the thrust requirement.
- Motorised torque ratings shown assume input speeds up to 230 rpm max. If higher actuator speeds are required please consult Rotork Gears.

7 Documentation

All customer specific documentation requirements can be supplied at extra cost.

8 Maintenance of Qualified Gearboxes

Rotork Gears is responsible for the generic and specific qualification of safety related gearboxes up to the expiry of the warranty period.

Any modifications required as a result of changes in customer specification may necessitate retesting of the gearboxes by qualified personnel and test equipment for the qualification documentation to be maintained. Similarly, repairs arising from transit or site damage to components likely to affect performance may also involve retesting to enable qualification to be maintained.

Any repairs under warranty will be carried out by Rotork using only qualified personnel. On completion of the warranty repair revised documentation if required will be provided. If retesting is required to maintain the qualification Rotork will undertake this and include the test report in the revised documentation pack. A certificate of conformance for the repair work will be provided as a matter of course.

From expiry of the warranty period, responsibility for the equipment, including maintenance of the qualification if required, passes to the owner. Rotork can provide qualified service engineers for site work, and can also provide training courses for customer personnel.

As the gearboxes are sealed and qualified to IEEE 382 service life, replacement of parts does not extend this qualified life. If it is desired that an inspection of the gearbox be carried out, Rotork can supply a kit of replacement screws, o-rings



and grease. Traceability documentation is supplied with all components. Records of gearboxes and any spare parts are to be maintained by the owner throughout all stages of product life, from storage, service to decommission.

9 Ordering Information

The following information must be given to Rotork to enable a bid to be made and an order to be processed for Nuclear gearboxes.

9.1 General

- 1 Project details (title, utility, NSSS supplier, contractor).
- 2 Reactor type.
- 3 Environmental conditions, normal and abnormal (ambient temperature and pressure, radiation, seismic).
- 4 Gearbox - general specification details and paint finish.
- 5 Approximate delivery required.
- 6 Documentation requirements.

9.2 For each Valve

- 1 Type of Valve.
- 2 Valve stem details (diameter and lead).
- 3 Valve Stroke or Turns for full travel.
- 4 Valve Torque and Thrust requirements.
- 5 Location in Plant (inside or Outside reactor Containment).
- 6 Is valve on Safety Related duty or is it non-Safety Related? If Safety Related, is it active or passive.
- 7 Seismic Category (active or passive).
- 8 Operating time.
- 9 Safety function.
- 10 Motorised or manual operation. If motorised, actuator information (model/speed or full details if non-Rotork actuator).



Redefining Flow Control

Rotork Gears UK
9 Brown Lane West
Holbeck, Leeds
LS12 6BH
England
tel +44 (0)113 256 7922
email sales@rotorkgears.com

Rotork Gears BV
Nijverheidstraat 25
7581 PV Losser
P.O. Box 98
7580 AB Losser
The Netherlands
tel +31 (0)53 - 5388677
fax +31 (0)53 - 5383939
email info@rotorkgears.nl

Rotork Gears India
165/166, Bommasandra,
Jigani Link Road,
Kiadb Industrial Area,
Anekal Thaluk,
Jigani Hobli, Bangalore 562106
India
tel +91 80 3098 1600
fax +91 80 3098 1610
email sales@rotork.co.in

Rotork Gears Americas
1811 Brittmoore
Houston
Texas 77043
USA
tel: +1 713 9837381
fax: +1 713 8568022
email: gears@rotorkgears.com

Rotork Gears Shanghai
No. 260 Lian Cao Road
Xin Mei Urban Industrial Park
Min Hang District
Shang Hai 201108
China
tel: 0086-21-64348388
fax: 0086-21-64348366
email: info@rotorkgears.com.cn

Rotork Valvekits
Brookside Way
Nunn Park
Huthwaite
Nottinghamshire NG17 2NL
England
tel: +44 (0)1623 440211
fax: +44 (0)1623 440214
email: sales@rotorkvalvekits.com

Rotork Gears S.R.L.
via Olona, 65/67
20015 Parabiago (MI)
Italy
tel +39 0331 552128
fax +39 0331 553147
email info@rotorkgears.it

Rotork Valvekits Americas
Renfro Associates Inc
501 South 12th Street
Broken Arrow, OK
74012 USA
tel +1 (918) 259-8100
fax +1 (918) 259-9167
email info@renfroassociates.com

www.rotork.com

A full listing of our worldwide sales and service network is available on our website.

Scan with your smart phone for more information on this product range

