

BIFFI

Double acting OLGA actuator for 90° operation for On-Off and Modulating heavy duty service

General

The OLGA hydraulic actuator series was engineered and is manufactured to provide maximum torque output with minimum supply pressure.

Simplicity, reliability and economy are at the top of the list of design parameters.

The OLGA actuator is suitable for any quarter turn application such as ball, plug, butterfly valves or dampers, in both On-Off and Modulating heavy duty service.

Features

- Totally enclosed, weatherproof housing in fabricated carbon steel for maximum strength
- Canted scotch yoke actuators are the proper solution to motorise the most common type of quarter-turn valves, due to their dedicated torque trend; they are suited to the larger valve sizes where high break away torques are required or for valves with high working pressure
- Symmetric scotch yoke actuators available for special applications
- External travel stops for precise angular stroke adjustment between 82° and 98°
- Hard chromium plated and polished guide bar and piston rod for corrosion resistance and minimal friction
- Bushings made of bronze or sintered bronze, charged with teflon, to provide minimal friction and extended service life
- Electroless nickel plated and polished cylinder for corrosion resistance and minimal friction
- Piston and piston rod seals made by a teflon ring precharged by an O-ring provide low hysteresis and high sensitivity, preventing sticking problems
- Jackscrew or hand pump manual override available
- An extensive range of accessories are available:
 - limit switch boxes - explosionproof, intrinsically safe and/or weatherproof
 - limit switches can be provided in different types according to customer requirements
 - position transmitters - explosionproof, intrinsically safe and/or weatherproof
 - oil filters
 - solenoid valves - explosionproof, intrinsically safe and/or weatherproof
 - control units for modulating service:
 - electrohydraulic "step-by-step"
 - electrohydraulic proportional valves complete with electronic control panel
 - electrohydraulic servovalves
 - spool-type or poppet-type (no leakage) control valves
 - dump valves, flow regulators, relief valves
 - electric pressure switches
 - bladder-type or piston-type accumulators ISPEL and TÜV stamped. Accumulators in accordance with different codes on request
 - electrohydraulic power packs, with explosionproof and/or weatherproof protection, assembled on the actuator or separate from the actuator
 - terminals enclosures, pushbutton panels - explosionproof or intrinsically safe and/or weatherproof
- Special coatings for offshore or corrosive environments



OLGA

Double Acting Hydraulic Actuator

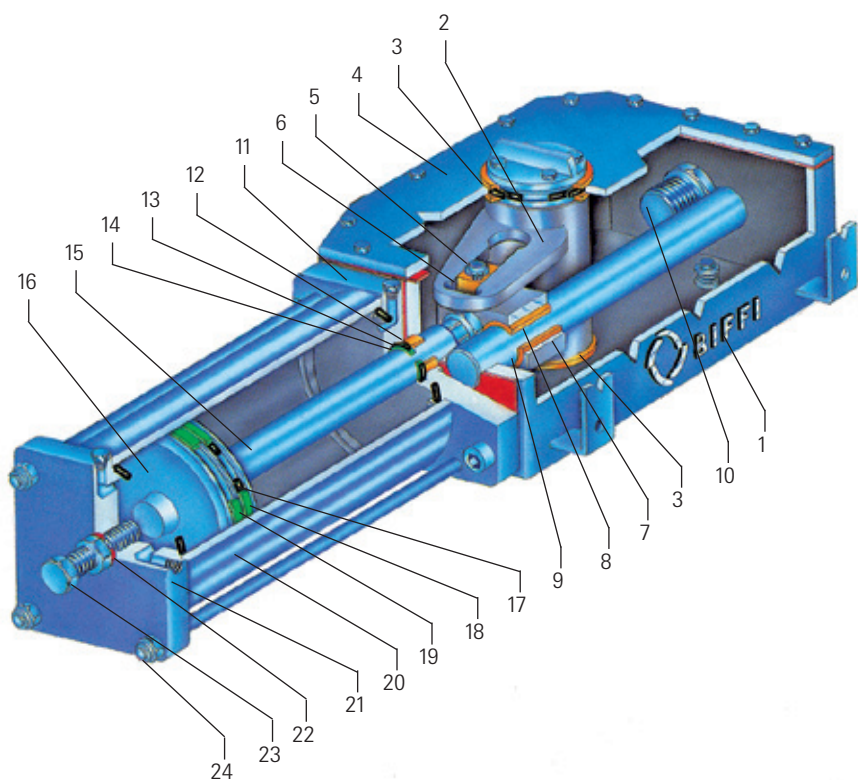

Item	Name
1	Housing
2	Yoke
3	Yoke bushing
4	Cover
5	Guide block pin
6	Sliding block
7	Guide block
8	Guide block bushing
9	Guide bar
10	Travel stop screw
11	Cylinder head flange
12	Piston rod bushing
13	Piston rod O-ring
14	Piston rod seal ring
15	Piston rod
16	Piston
17	Piston O-ring
18	Piston seal ring
19	Piston guide sliding ring
20	Cylinder tube
21	End flange
22	Sealing washer
23	Travel stop screw
24	Tie rod

OLGA Actuators

Model	Oil displacement (litres)
0.3 - 75	0.7
0.3 - 100	1.2
0.9 - 100	1.4
0.9 - 135	2.4
1.5 - 135	3
1.5 - 175	5
3 - 135	5
3 - 175	8
6 - 175	10
6 - 200	12
14 - 200	13
14 - 235	18
14 - 280	26
18 - 235	21
18 - 280	30
32 - 235	25
32 - 280	35
50 - 235	27
50 - 280	39
50 - 300	45

Technical data

Supply pressure	: 105 bar g maximum
Supply fluid	: hydraulic oil Special versions for fire-resistant fluids
Ambient temperature	: -30° C to +100° C Special versions for service outside this range on request
Output torques	: up to 400000 Nm Higher values with special versions

Note

The oil displacement is the oil volume required for one actuator stroke in opening or in closing)

Output Torques for Canted Yoke Mechanism

Model	Max operating torque (Nm)	Output torque (Nm/bar g)		
		at 0°	at 45°	at 90°
0.3C - 75	3000	64	22	31
0.3C - 100	3000	115	41	57
0.9C - 100	9000	132	47	65
0.9C - 135	9000	243	87	120
1.5C - 135	15000	304	108	150
1.5C - 175	15000	512	184	255
3C - 135	30000	493	176	244
3C - 175	30000	829	298	412
6C - 175	60000	970	348	482
6C - 200	60000	1320	451	624
14C - 200	120000	1446	515	713
14C - 235	120000	1912	700	969
14C - 280	120000	2715	996	1379
18C - 235	180000	2197	805	1114
18C - 280	180000	3122	1146	1586
32C - 235	300000	2616	955	1323
32C - 280	300000	3707	1360	1883
50C - 235	400000	2934	1073	1486
50C - 280	400000	4165	1528	2116
50C - 300	400000	4782	1739	2407

Notes

- Max allowable pressure 105 bar g (static pressure applicable to fully stroked actuator against the travel stops)
- Angular positions: 0° Closed
45° Intermediate
90° Open

Output Torques for Symmetric Yoke Mechanism

Model	Max operating torque (Nm)	Output torque (Nm/bar g)		
		at 0°	at 45°	at 90°
0.3S - 75	3000	40	23	38
0.3S - 100	3000	73	42	69
0.9S - 100	9000	85	49	80
0.9S - 135	9000	154	89	146
1.5S - 135	15000	212	113	169
1.5S - 175	15000	356	191	287
3S - 135	30000	346	187	285
3S - 175	30000	582	316	482
6S - 175	60000	679	370	565
6S - 200	60000	887	479	732
14S - 200	120000	985	523	786
14S - 235	120000	1360	742	1115
14S - 280	120000	1931	1056	1588
18S - 235	180000	1564	853	1283
18S - 280	180000	2220	1215	1827
32S - 235	300000	1812	1003	1529
32S - 280	300000	2573	1428	2177
50S - 235	400000	2013	1114	1699
50S - 280	400000	2858	1586	2419
50S - 300	400000	3281	1804	2751

Overall dimensions

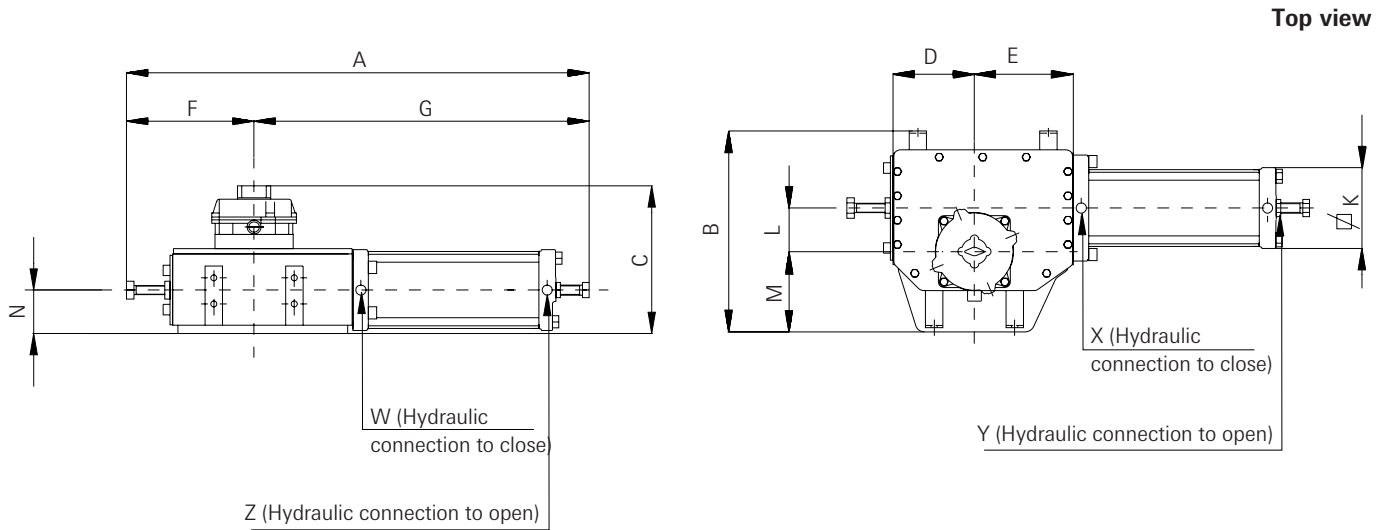

Dimensions in mm

Model	A	B	C	D	E	F	G	∅ K	L	M	N	Hydraulic connection NPT (X-Y)	Hydraulic connection NPT (W-Z)	Weight (Kg)
0.3* - 75	756	319	279	136	151	222	534	116	70	119	70	1/2	-	44
0.3* - 100	803	319	279	136	151	222	581	125	70	119	70	1/2	-	48
0.9* - 100	870	413	303	160	190	245	625	160	80	170	83	1/2	-	60
0.9* - 135	921	413	303	160	190	245	676	160	80	170	83	1/2	-	79
1.5* - 135	1011	469	343	187	227	293	718	160	100	185	100	1/2	-	116
1.5* - 175	1056	469	343	187	227	293	763	196	100	185	100	1/2	-	135
3* - 135	1451	586	351	285	330	391	1060	160	160	215	106	1/2	-	190
3* - 175	1532	586	351	285	330	391	1141	196	160	215	106	1/2	-	220
6* - 175	1625	740	414	327	379	430	1195	196	185	260	140	1/2	-	360
6* - 200	1705	740	414	327	379	430	1275	230	185	260	140	-	3/4	398
14* - 200	1826	873	527	376	435	496	1330	230	200	330	193	-	3/4	600
14* - 235	1806	873	527	376	435	496	1310	∅ 340	200	330	193	-	3/4	650
14* - 280	1842	873	527	376	435	496	1346	350	200	330	193	-	3/4	700
18* - 235	1972	880	511	424	492	548	1424	∅ 340	230	330	196	-	3/4	800
18* - 280	1953	880	511	424	492	548	1405	350	230	330	196	-	3/4	850
32* - 235	2263	1055	583	505	585	643	1620	∅ 340	270	395	232	-	3/4	1350
32* - 280	2263	1055	583	505	585	643	1620	350	270	395	232	-	3/4	1380
50* - 235	2460	1092	584	548	633	700	1760	∅ 340	300	387	233	-	3/4	1500
50* - 280	2460	1092	584	548	633	700	1760	350	300	387	233	-	3/4	1540
50* - 300	2500	1092	584	548	633	700	1800	392	300	387	233	-	3/4	1580

Notes

- 1.* Add C for canted yoke, S for symmetric yoke (i.e. 0.3C - 135)
2. Dimensions and weights given are with oil and without optional bracket or adaptor flange
3. For mounting flange details see separate coupling dimensions leaflet

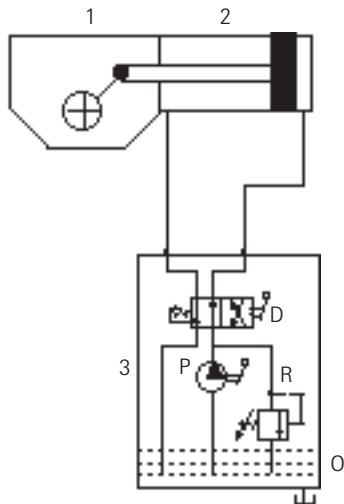

- 1. Scotch yoke mechanism
- 2. Hydraulic cylinder
- 3. Hydraulic manual override
- D= Directional control valve
- P= Hand pump
- R= Relief valve
- O= Oil tank

Local manual control

The OLGA actuators can only have the hydraulic manual override for the operation. The compact hydraulic control unit mounted on the actuator consists of :

- hand pump
- directional control valve to select the "to open" or "to close" actuator operation
- relief valve to prevent the oil pressure delivered by the hand pump from exceeding the maximum allowable value
- oil tank

Accessories are available on request, for instance:

- dual pilot operated check valve
- bladder-type or piston-type accumulator

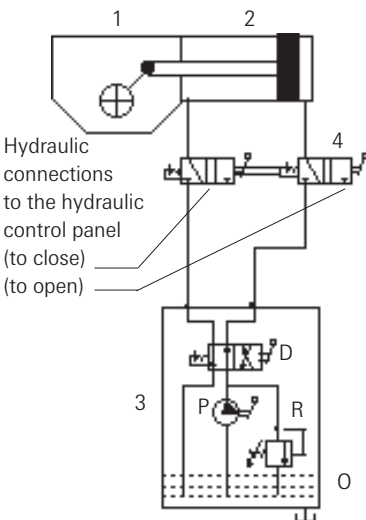
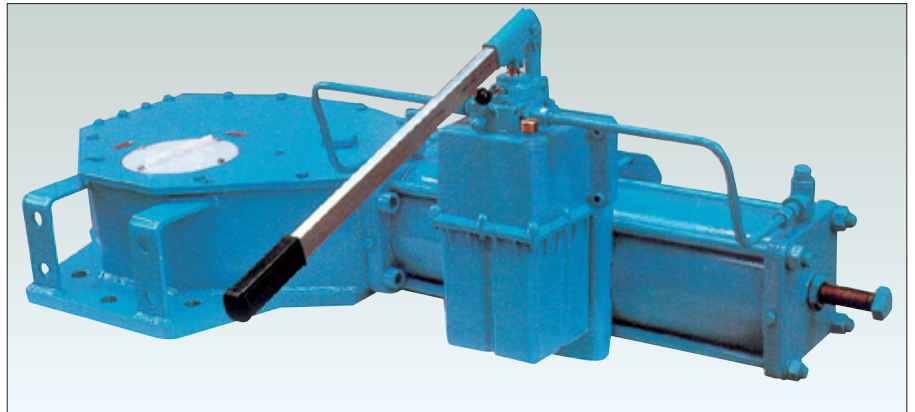

- 1. Scotch yoke mechanism
- 2. Hydraulic cylinder
- 3. Hydraulic manual override
- 4. Hydraulic manual selector
- D= Directional control valve
- P= Hand pump
- R= Relief valve
- O= Oil tank

Emergency manual override

The OLGA actuators can have an emergency manual override in addition to the local and/or remote control panel which controls the oil supplied by a power pack for the "normal" actuator operation. The emergency manual override, mounted on the actuator, consists of a hydraulic manual override and a hydraulic manual selector to choose actuator "Normal operation" with oil supply from a power pack, or the "Emergency manual operation".

The compact hydraulic manual override consists of:

- hand pump
- directional control valve to select the "to open" or "to close" operation by hand pump
- relief valve to prevent the oil pressure delivered by the hand pump from exceeding the maximum allowable value

On request the emergency manual override can be included in the power pack.

OLGA

Double Acting Hydraulic Actuator

Manual override type "MSJ"

The MSJ jackscrew manual override can be supplied for OLGA and OLGA-H actuators up to model 3. The override is mounted on the left side of the actuator, the jackscrew end is screwed into the guide block. A bronze split screw nut is mounted inside the body. By rotating the engagement lever, the screw nut is engaged with the jackscrew. When the screw nut is engaged with the jackscrew manual operation follows by rotating the body of the screw container by a lever.

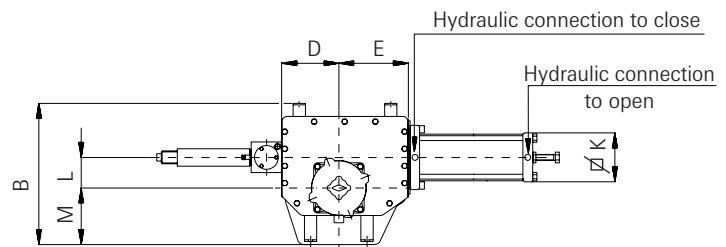
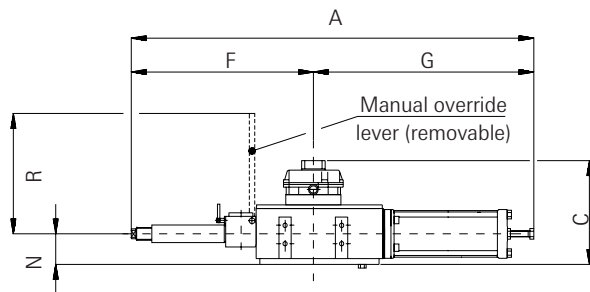
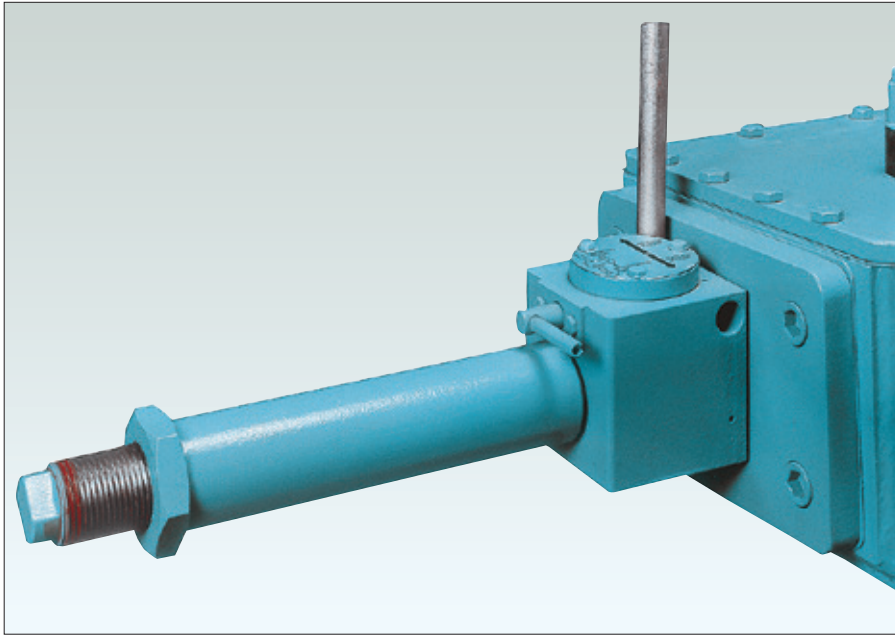

Top view

Dimensions in mm

Model	A	B	C	D	E	F	G	∅K	L	M	N	R	Jackscrew turns per stroke	Hydraulic connection NPT	Weight (Kg)
0.3* - 75-MSJ	1021	319	279	136	151	487	534	116	70	119	70	437	30	1/2	55
0.3* - 100-MSJ	1068	319	279	136	151	487	581	125	70	119	70	437	30	1/2	59
0.9* - 100-MSJ	1136	413	303	160	190	511	625	125	80	170	83	437	35	1/2	71
0.9* - 135-MSJ	1187	413	303	160	190	511	676	160	80	170	83	437	35	1/2	90
1.5* - 135-MSJ	1314	469	343	187	227	596	718	160	100	185	100	627	35	1/2	130
1.5* - 175-MSJ	1359	469	343	187	227	596	763	196	100	185	100	627	35	1/2	149
3* - 135-MSJ•	1977	586	351	285	330	917	1060	160	160	215	106	627	56	1/2	207
3* - 175-MSJ•	2058	586	351	285	330	917	1141	196	160	215	106	627	56	1/2	237

Notes

- * Add C for canted yoke, S for symmetric yoke (i.e. 0.3C - 135)
- Max operating torque with jackscrew manual override is 19000 Nm
- Dimensions and weights given are with oil and without optional bracket or adaptor flange

Mechanical Manual Override

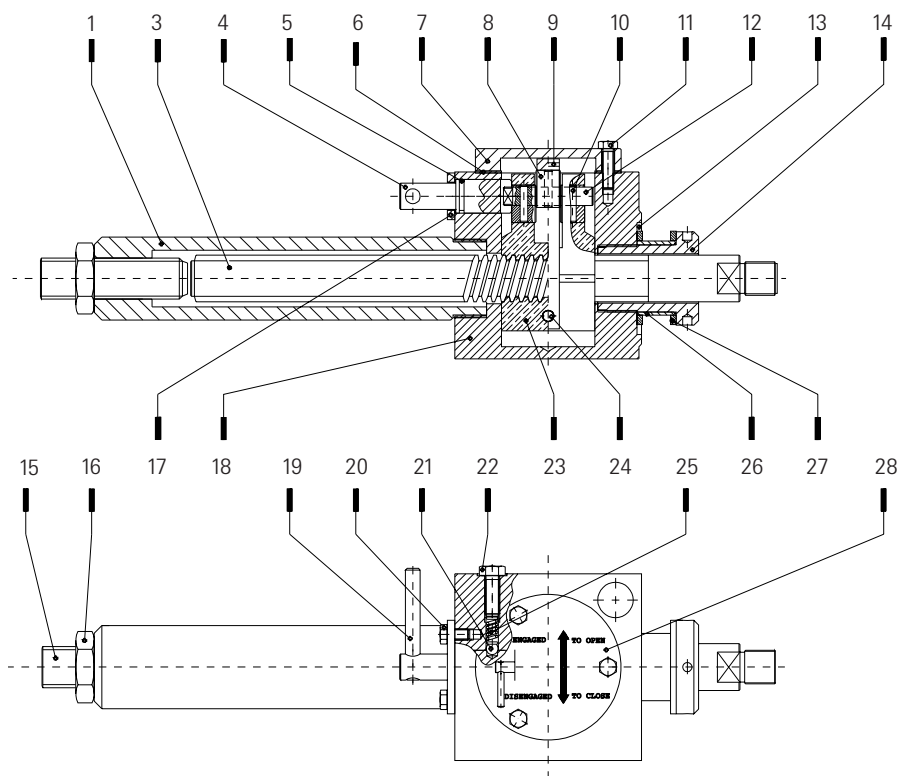

Materials specification

Item	Name	Material	Equivalence to U.S. standards	Q.ty
1	Protection pipe	Carbon steel	API 5LX gr X52	1
3	Jackscrew	Carbon steel	AISI SAE 1040	1
4	Engagement lever pin	Stainless steel	ASTM A479 Type 304	1
5	O-ring	Fluorosilicon rubber		1 •
6	Cover gasket	Fibre		1 •
7	Cover	Carbon steel	ASTM A283 gr D	1
8	Cam	Alloy steel	AISI SAE 9840	3
9	Fork	Carbon steel	AISI SAE 1040	1
10	Spring pin	Stainless steel	ASTM A479 Type 302	3
11	Screw	Carbon steel	AISI SAE 1040	3
12	Screw nut operating cam	Alloy steel	AISI SAE 9840	1
13	O-ring	Fluorosilicon rubber		1 •
14	Thrust block ring nut	Alloy steel	AISI SAE 9840	1
15	Travel stop screw	Carbon steel	AISI SAE 1040	1
16	Nut	Carbon steel	ASTM A194 gr 2	1
17	Flange	Carbon steel	ASTM A283 gr D	1
18	Body	Carbon steel	ASTM A283 gr D	1
19	Spring pin	Spring steel	ASTM A29 gr 4047	1
20	Screw	Carbon steel	AISI SAE 1040	2
21	Ball	Stainless steel	ASTM A479 Type 304	1
22	Screw	Carbon steel	AISI SAE 1040	1
23	Screw nut	Bronze	ASTM B427 Alloy UNS No. C90800	1
24	Pin	Carbon steel	AISI SAE 1040	1
25	Spring	Spring steel	ASTM A29 gr 9254	1
26	Bush	Bronze	ASTM B427 Alloy UNS No. C90800	1
27	Thrust shoulder washer	Bronze	ASTM B427 Alloy UNS No. C90800	2
28	Operating instruction plate	Aluminium	ASTM B221 Alloy 6351	

• Recommended spare parts

Spring return OLGAS actuator for 90° operation for On-Off and Modulating heavy duty service**General**

The OLGAS hydraulic spring return actuator series was engineered and is manufactured to provide fail safe operation for any quarter turn application such as ball, plug, butterfly valves or dampers, in both On-Off and Modulating heavy duty service.

Simplicity, reliability and economy are at the top of the list of design parameters.

The spring module incorporates up to four springs, fully encapsulated in a factory-welded cartridge.

This ensures safety to personnel and ease of assembly.

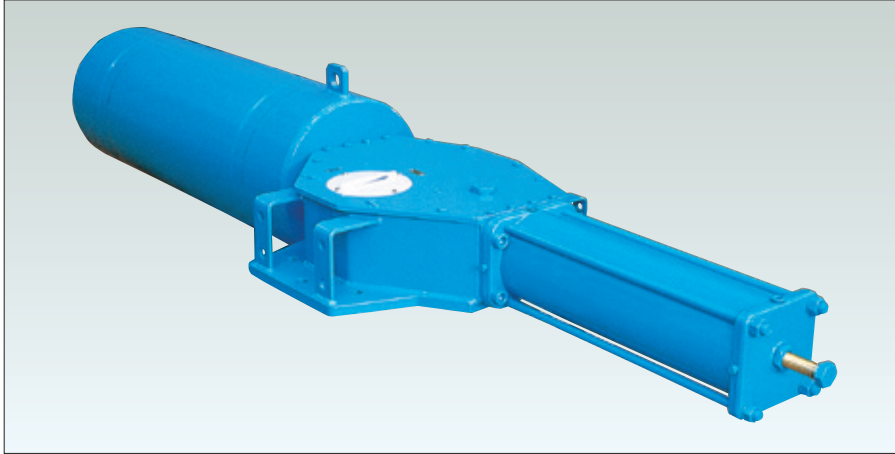
**Features**

- Totally enclosed, weatherproof housing in fabricated carbon steel for maximum strength
- Canted scotch yoke actuators are the proper solution to motorise the most common type of quarter-turn valves, due to their dedicated torque trend; they are suited to the larger valve sizes where high break away torques are required or for valves with high working pressure
- Symmetric scotch yoke actuators available for special applications
- External travel stops for precise angular stroke adjustment between 82° and 98°
- Hard chromium plated and polished guide bar and piston rod for corrosion resistance and minimal friction
- Bushings made of bronze or sintered bronze, charged with teflon, to provide minimal friction and extended service life
- Electroless nickel plated and polished cylinder for corrosion resistance and minimal friction
- Piston and piston rod seals made by a teflon ring precharged by an O-ring provide low hysteresis and high sensitivity of actuator, preventing sticking problems
- Hand pump manual override available
- Spring module to provide fail-safe operation
- The spring return pack incorporates up to four springs, fully encapsulated in a factory welded cartridge: this ensures safety to personnel and simplifies assembly
- The spring action can be easily changed in the field from to close in to open or viceversa (modular design)
- An extensive range of accessories are available:
 - limit switch boxes explosionproof, intrinsically safe and/or weatherproof; limit switches can be provided in different types according to customer requirements
 - position transmitters explosionproof, intrinsically safe and/or weatherproof
 - oil filters
 - solenoid valves - explosionproof, intrinsically safe and/or weatherproof;
 - control units for modulating service:
 - electrohydraulic "step-by-step"
 - electrohydraulic proportional valves complete with electronic control panel
 - electrohydraulic servovalves
 - spool-type or poppet-type (no leakage) control valves
 - dump valves, flow regulators, relief valves
 - electric pressure switches
 - bladder-type or piston-type accumulators ISPEL and TÜV stamped. Accumulators in accordance with different codes on request
 - electrohydraulic power packs, with explosionproof and/or weatherproof protection, assembled on the actuator or separate from the actuator
 - terminals enclosures, pushbutton panels - explosionproof or intrinsically safe and/or weatherproof
- Special coatings for offshore or corrosive environments
- Special versions with built-in dump valves and dumper for "quick spring operation"

OLGAS actuators

Model	Oil displacement (litres)
0.3-0150-100	1.2
0.3-0150-75	0.7
0.9-0200-135	2.4
0.9-0200-100	1.4
0.9-0350-135	2.4
0.9-0350-100	1.4
0.9-0400-135	2.4
0.9-0400-100	1.4
0.9-0700-135	2.4
0.9-0700-100	1.4
1.5-1100-175	5
1.5-1100-135	3
1.5-1200-175	5
1.5-1200-135	3
3-2000-175	8
3-2000-135	5
6-2500-200	12
6-2500-175	10
6-3800-200	12
6-3800-175	10
14-5400-280	26
14-5400-235	18
14-5400-200	13
14-8300-280	26
14-8300-235	18
14-8300-200	13
18-9600-280	30
18-9600-235	21
18-9800-280	30
18-9800-235	21

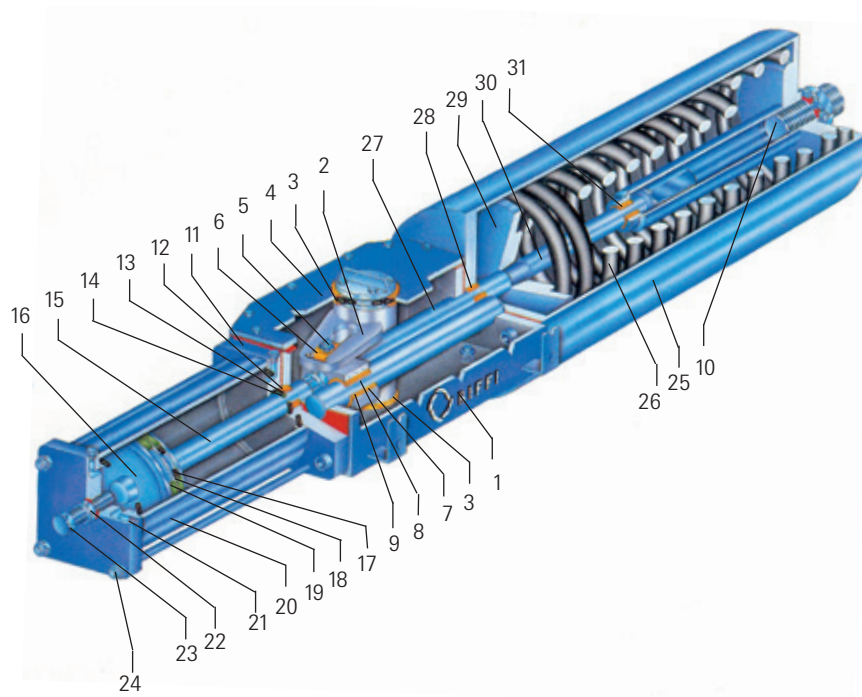

Item	Name
1	Housing
2	Yoke
3	Yoke bushing
4	Cover
5	Guide block pin
6	Sliding block
7	Guide block
8	Guide bar
9	Guide block bushing
10	Travel stop screw
11	Cylinder head flange
12	Piston rod bushing
13	Piston rod O-ring
14	Piston rod seal ring
15	Piston rod
16	Piston
17	Piston O-ring
18	Piston seal ring
19	Piston guide sliding ring
20	Cylinder tube
21	End flange
22	Sealing washer
23	Travel stop screw
24	Tie rod
25	Spring container
26	Spring
27	Container rod
28	Container rod bushing
29	Spring thrust flange
30	Guide rod
31	Guide rod bushing

Technical data

Supply pressure	: 105 bar g maximum
Supply fluid	: hydraulic oil Special versions for fire-resistant fluids
Ambient temperature	: -30° C to +100° C Special versions for service outside this range on request
Spring ending torques	: from 390 up to 80000 Nm Higher values with special versions

Note

The oil displacement is the oil volume required for one actuator stroke (in opening or in closing)

Output Torques for Spring to Close Canted Yoke Mechanism (in daNm)

Model	Spring Torque			Operating supply pressure (bar g)																		
				20			30			40			50			60			70			80
	SET	SRT	SST	OST	ORT	OET	OST	ORT	OET	OST	ORT	OET	OST	ORT	OET	OST	ORT	OET	OST	ORT	OET	
0.3-0150-100-CL	78	43	74	146	40	46	249	86	112													
0.3-0150-75-CL	80	44	74				111	26	26	177	52	63	243	78	100							
0.9-0200-135-CL	100	56	97	376	125	162	623	221	301													
0.9-0200-100-CL	103	57	98	157	37	38	292	91	115	427	145	191	563	198	267	698	251	344				
0.9-0350-135-CL	198	109	185	278	63	65	525	163	204													
0.9-0350-100-CL	202	110	187							329	85	94	465	139	170	600	193	246				
0.9-0400-135-CL	267	134	219				456	136	165	695	233	304										
0.9-0400-100-CL	270	135	221										396	112	131	532	166	208	667	219	284	
0.9-0700-135-CL	355	186	310				368	65	65	615	174	205										
0.9-0700-100-CL	359	187	312													443	104	108	579	160	184	
1.5-1100-175-CL	522	321	573				1020	237	245													
1.5-1100-135-CL	527	323	575							700	64	64	1010	233	240							
1.5-1200-175-CL	714	391	664				828	140	140													
1.5-1200-135-CL	720	393	666										820	135	135	1130	286	311				
3-2000-175-CL	1130	589	977				1410	341	360	2280	691	849										
3-2000-135-CL	1140	592	981										1400	335	352	1910	546	644	2430	751	935	
6-2500-200-CL	1700	853	1390				2200	586	659	3530	1110	1400	4850	1630	2150							
6-2500-175-CL	1700	854	1390							2290	620	707	3300	1020	1270	4320	1420	1850				
6-3800-200-CL	2540	1190	1880							2690	738	849	4010	1260	1590							
6-3800-175-CL	2550	1190	1880										2460	647	722	3480	1050	1290	4490	1450	1860	
14-5400-280-CL	3670	1800	2930				4750	1300	1500	7590	2490	3100	9990	3550	4700							
14-5400-235-CL	3680	1800	2930							4240	1090	1210	6240	1900	2330	8240	2680	3460				
14-5400-200-CL	3680	1810	2930													4940	1370	1600	6390	1950	2420	7830 2520 3230
14-8300-280-CL	4800	2330	3770							6470	1840	2160	9310	2960	3760							
14-8300-235-CL	4810	2330	3770										5120	1290	1400	7120	2090	2530	9120	2890	3650	
14-8300-200-CL	4810	2330	3770													3810	669	669	5260	1350	1480	6710 1930 2300
18-9600-280-CL	6460	3570	6100										9770	2320	2440	13040	3660	4280				
18-9600-235-CL	6480	3580	6110																9560	2230	2320	11870 3190 3620
18-9800-280-CL	7990	4490	7730													11510	2500	2500	14780	3880	4340	
18-9800-235-CL	8010	4500	7750																			10340 1840 1840

Notes

- Max allowable pressure 105 bar g (static pressure applicable to fully stroked actuator against the travel stop)
- Angular positions:
 - 0° Closed
 - 45° Intermediate
 - 90° Open
- SET : Spring Ending Torque to close (0°)
- SRT : Spring Running Torque (45°)
- SST : Spring Starting Torque to close (90°)
- OST : Oil Starting Torque to open (0°)
- ORT : Oil Running Torque (45°)
- OET : Oil Ending Torque to open (90°)

Output Torques for Spring to Open Canted Yoke Mechanism (in daNm)

Model	Spring Torque			Operating supply pressure (bar g)																				
				20			30			40			50			60			70			80		
	SET	SRT	SST	OST	ORT	OET	OST	ORT	OET	OST	ORT	OET	OST	ORT	OET	OST	ORT	OET	OST	ORT	OET	OST	ORT	OET
0.3-0150-100-OP	136	36	40	82	44	75	212	91	139															
0.3-0150-75-OP	138	37	41				43	30	56	116	57	92	189	83	128	262	109	163						
0.9-0200-135-OP	172	43	47	316	133	202	590	230	336															
0.9-0200-100-OP	176	45	49	72	46	83	223	100	157	373	154	230	523	207	303	673	260	377						
0.9-0350-135-OP	331	86	95	121	81	148	395	180	282	669	277	415												
0.9-0350-100-OP	334	87	96							178	102	176	328	156	249	479	209	322	629	263	396			
0.9-0400-135-OP	393	111	129				319	152	244	593	250	378												
0.9-0400-100-OP	396	112	131							102	74	139	253	129	212	403	182	285	553	236	359	699	289	432
0.9-0700-135-OP	556	150	171				120	99	195	393	200	329	667	298	462									
0.9-0700-100-OP	559	152	173													203	130	226	353	185	309	504	239	303
1.5-1100-175-OP	1010	232	239				469	302	547	1050	513	831												
1.5-1100-135-OP	1010	234	242										460	299	543	807	425	712	1150	550	881			
1.5-1200-175-OP	1170	305	337				262	223	443	844	438	727												
1.5-1200-135-OP	1180	307	340										254	220	439	600	349	608	946	474	777			
3-2000-175-OP	1730	473	541				699	429	762	1660	777	1230	2490	1146	1798									
3-2000-135-OP	1740	476	545										685	423	755	1250	632	1030	1830	836	1310	2400	1040	1590
6-2500-200-OP	2470	695	810				1290	705	1190	2760	1230	1910	4230	1750	2630									
6-2500-175-OP	2480	696	812							1390	740	1240	2510	1140	1790	3640	1540	2340	4760	1940	2890			
6-3800-200-OP	3370	1010	1230							1660	874	1450	3130	1400	2170	4610	1920	2890						
6-3800-175-OP	3370	1010	1230										1410	783	1330	2540	1180	1880	3670	1580	2430	4790	1980	2980
14-5400-280-OP	5210	1490	1760				2930	1540	2570	6090	2660	4110	9240	3780	5650									
14-5400-235-OP	5220	1490	1760							2370	1330	2290	4590	2130	3370	6810	2920	4460	9030	3700	5540			
14-5400-200-OP	5220	1490	1760										1530	1020	1880	3140	1610	2670	4750	2190	3450	6360	2760	4240
14-8300-280-OP	6700	1930	2290							4260	2140	3510	7420	3260	5050									
14-8300-235-OP	6700	1930	2300				1110	980	1970				2770	1600	2780	4990	2400	3860	7210	3190	4940	9430	3980	6030
14-8300-200-OP	6700	1930	2300													1320	1060	2070	2930	1650	2850	4540	2240	3640
18-9600-280-OP	10660	2690	2940										4910	3010	5350	8530	4320	7120	12160	5620	8890			
18-9600-235-OP	10680	2700	2950													2120	1960	3990	4680	2920	5240	7320	3850	6480
18-9800-280-OP	13510	3360	3630													5040	3410	6290	8660	4740	8060	12990	6050	9830
18-9800-235-OP	13530	3370	3640																			3740	2920	5660

Notes

- Max allowable pressure 105 bar g (static pressure applicable to fully stroked actuator against the travel stop)
- Angular positions: 0° Closed
45° Intermediate
90° Open
- SST : Spring Starting Torque to open (0°)
SRT : Spring Running Torque (45°)
SET : Spring Ending Torque to open (90°)
OET : Oil Ending Torque to close (0°)
ORT : Oil Running Torque (45°)
OST : Oil Starting Torque to close (90°)

Output Torques for Spring to Close Symmetric Yoke Mechanism (in daNm)

Model	Spring Torque			Operating supply pressure (bar g)																							
				20			30			40			50			60			70			80					
	SET	SRT	SST	OST	ORT	OET	OST	ORT	OET	OST	ORT	OET	OST	ORT	OET	OST	ORT	OET	OST	ORT	OET	OST	ORT	OET			
0.3S-0150-100-CL	54	42	91	87	42	55	161	90	139	234	136	223															
0.3S-0150-75-CL	56	43	92				65	28	30	107	55	77	148	81	125	189	108	172	231	134	219						
0.9S-0200-135-CL	69	55	120	230	129	203	385	228	380	540	326	557															
0.9S-0200-100-CL	71	56	122	93	40	45	178	96	142	263	150	240	348	204	337	433	285	434	518	312	531	603	366	629			
0.9S-0350-135-CL	137	106	229	164	69	75	319	171	252	474	270	429	629	368	607												
0.9S-0350-100-CL	139	108	231							196	91	112	281	146	209	366	201	306	451	255	404	536	309	501			
0.9S-0400-135-CL	180	132	207				276	143	203	431	242	380	586	341	558												
0.9S-0400-100-CL	183	133	272							153	62	63	238	119	160	323	173	257	408	228	354	493	282	452			
0.9S-0700-135-CL	243	182	383							369	184	249	524	284	426	679	383	604									
0.9S-0700-100-CL	245	184	385													262	114	126	347	169	223	432	225	320			
1.5S-1100-175-CL	368	304	624				687	265	293	1040	481	638															
1.5S-1100-135-CL	372	306	627										681	261	288	894	391	493	1110	519	698						
1.5S-1200-175-CL	500	375	724				556	171	171	913	404	515															
1.5S-1200-135-CL	504	377	727										550	165	165	763	313	370	976	442	576	1190	568	781			
3S-2000-175-CL	792	570	1090				933	377	430	1520	733	1010	2100	1080	1590												
3S-2000-135-CL	798	573	1090										925	371	421	1270	585	766	1620	794	1110	1970	1000	1460			
6S-2500-200-CL	1180	830	1560				1460	635	785	2350	1170	1670	3240	1710	2560	4130	2240	3450	4990	2770	4330						
6S-2500-175-CL	1180	831	1560							1510	670	843	2200	1080	1520	2880	1490	2200	3560	1900	2880	4240	2300	3560			
6S-3800-200-CL	1760	1170	2110							1780	795	1010	2670	1330	1900	3560	1870	2780	4450	2400	3670						
6S-3800-175-CL	1760	1170	2120										1630	702	860	2310	1120	1540	2990	1530	2220	3670	1930	2900			
14S-5400-280-CL	2550	1750	3200				3200	1400	1770	5140	2550	3640	7070	3690	5500	9010	4830	7370									
14S-5400-235-CL	2570	1760	3210							2860	1200	1440	4230	2010	2760	5590	2820	4070	6950	3620	5390	8310	4420	6700			
14S-5400-200-CL	2570	1760	3210										2350	879	946	3340	1480	1900	4320	2070	2850	5310	2660	3800			
14S-8300-280-CL	3340	2270	4120							4370	1970	2560	6300	3120	4420	8240	4260	6290	9990	5390	8160						
14S-8300-235-CL	3350	2270	4130										3450	1420	1670	4820	2240	2990	6180	3050	4300	7540	3850	5620			
14S-8300-200-CL	3350	2280	4130																3550	1480	1770	4540	2070	2720			
18S-9600-280-CL	4550	3440	6680										6540	2560	2890	8770	3920	5040	10990	5240	7190	13210	6560	9330			
18S-9600-235-CL	4560	3450	6690													4830	1240	1240	6400	2480	2750	7970	3440	4270			
18S-9800-280-CL	5610	4300	8440													7720	2840	3000	9940	4220	5150	12170	5560	7300			
18S-9800-235-CL	5630	4310	8450																			6920	2230	2230			

Notes

- Max allowable pressure 105 bar g (static pressure applicable to fully stroked actuator against the travel stop)
- Angular positions:
 - 0° Closed
 - 45° Intermediate
 - 90° Open
- SET : Spring Ending Torque to close (0°)
- SRT : Spring Running Torque (45°)
- SST : Spring Starting Torque to close (90°)
- OST : Oil Starting Torque to open (0°)
- ORT : Oil Running Torque (45°)
- OET : Oil Ending Torque to open (90°)

Output Torques for Spring to Open Symmetric Yoke Mechanism (in daNm)

Model	Spring Torque			Operating supply pressure (bar g)																				
				20			30			40			50			60			70			80		
	SET	SRT	SST	OST	ORT	OET	OST	ORT	OET	OST	ORT	OET	OST	ORT	OET	OST	ORT	OET	OST	ORT	OET	OST	ORT	OET
0.3S-0150-100-OP	82	39	49	57	44	93	139	91	170	222	138	247												
0.3S-0150-75-OP	83	39	50				32	29	71	79	56	114	125	83	157	172	109	200	218	136	243			
0.9S-0200-135-OP	103	47	57	207	134	248	381	233	409	555	331	570												
0.9S-0200-100-OP	105	49	59	53	45	104	148	100	193	243	154	281	339	209	370	434	263	458	529	317	546	625	371	635
0.9S-0350-135-OP	198	92	114	89	78	185	263	179	346	437	278	508	611	377	669									
0.9S-0350-100-OP	200	94	116				30	30	130	125	100	219	221	155	307	316	209	396	411	264	484	507	318	572
0.9S-0400-135-OP	237	118	159				215	151	302	389	251	463	562	349	624									
0.9S-0400-100-OP	239	119	161							77	71	174	173	127	262	268	182	351	363	236	439	459	290	528
0.9S-0700-135-OP	334	161	208				95	94	246	269	197	407	442	297	568									
0.9S-0700-100-OP	336	162	211										53	53	206	148	127	295	243	183	383	339	238	472
1.5S-1100-175-OP	681	261	288				333	285	596	733	499	910	1130	710	1190									
1.5S-1100-135-OP	684	263	291										327	282	591	565	410	778	803	536	965	1040	661	1150
1.5S-1200-175-OP	796	333	402				190	190	482	591	423	795	991	634	1110									
1.5S-1200-135-OP	799	335	405													423	333	663	661	460	850	899	586	1040
3S-2000-175-OP	1150	511	646				495	409	805	1150	762	1380	1800	1110	1900	2460	1460	2430						
3S-2000-135-OP	1160	515	652										485	403	842	875	615	1160	1260	823	1470	1650	1030	1780
6S-2500-200-OP	1640	747	968				908	681	1340	1910	1220	2150	2900	1750	2950	3900	2280	3760	4900	2800	4570			
6S-2500-175-OP	1640	748	970							972	716	1390	1740	1130	2010	2500	1530	2630	3260	1940	3240	4030	2340	3860
6S-3800-200-OP	2240	1070	1470							1170	848	1630	2160	1380	2440	3160	1910	3250	4160	2440	4050	4990	2970	4860
6S-3800-175-OP	2240	1080	1470										996	756	1500	1760	1170	2110	2520	1570	2730	3290	1980	3350
14S-5400-280-OP	3520	1600	2080				2050	1480	2810	4220	2630	4500	6390	3760	6200	8560	4890	7900						
14S-5400-235-OP	3530	1600	2090							1670	1280	2510	3200	2090	3700	4720	2890	4900	6250	3690	6090	7780	4480	7300
14S-5400-200-OP	3540	1600	2090										1090	966	2060	2200	1560	2920	3310	2150	3790	4410	2730	4660
14S-8300-280-OP	4530	2070	2710				808	808	2140	2980	2080	3840	5150	3210	5530	7310	4350	7230	9480	5480	8930			
14S-8300-235-OP	4540	2070	2720										1950	1530	3040	3480	2340	4230	5010	3140	5430	6540	3940	6620
14S-8300-200-OP	4540	2070	2720													956	956	2260	2060	1590	3120	3170	2180	3990
18S-9600-280-OP	7160	2940	3480										3500	2870	5850	5990	4210	7810	8480	5520	9760	10980	6820	11710
18S-9600-235-OP	7170	2950	3490													1580	1580	4350	3340	2780	5730	5090	3730	7110
18S-9800-280-OP	9090	3700	4330													3590	3200	6860	6090	4560	8810	8580	5880	10760
18S-9800-235-OP	9100	3710	4340																			2700	2690	6160

Notes

- Max allowable pressure 105 bar g (static pressure applicable to fully stroked actuator against the travel stop)
- Angular positions: 0° Closed
 45° Intermediate
 90° Open
- SST : Spring Starting Torque to open (0°)
 SRT : Spring Running Torque (45°)
 SET : Spring Ending Torque to open (90°)
 OET : Oil Ending Torque to close (0°)
 ORT : Oil Running Torque (45°)
 OST : Oil Starting Torque to close (90°)

Maximum Operating Torque

Model	Max operating torque (Nm)
0.3-0150-100	3000
0.3-0150-75	3000
0.9-0200-135	9000
0.9-0200-100	9000
0.9-0350-135	9000
0.9-0350-100	9000
0.9-0400-135	9000
0.9-0400-100	9000
0.9-0700-135	9000
0.9-0700-100	9000
1.5-1100-175	15000
1.5-1100-135	15000
1.5-1200-175	15000
1.5-1200-135	15000
3-2000-175	30000
3-2000-135	30000
6-2500-200	60000
6-2500-175	60000
6-3800-200	60000
6-3800-175	60000
14-5400-280	120000
14-5400-235	120000
14-5400-200	120000
14-8300-280	120000
14-8300-235	120000
14-8300-200	120000
18-9600-280	180000
18-9600-235	180000
18-9800-280	180000
18-9800-235	180000

Notes

- Max allowable pressure 105 bar g (static pressure applicable to fully stroked actuator against travel stop)
- Add S to the model number to identify actuators with symmetric yoke (i.e. 0.3S-0150-100)
- Add CL or OP to the model number to identify spring to close or spring to open (i.e. 0.3-0150-100 CL)

Overall dimensions for spring to close actuators

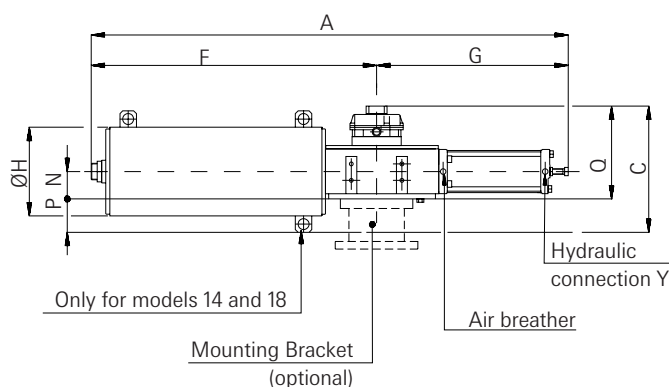

Top view

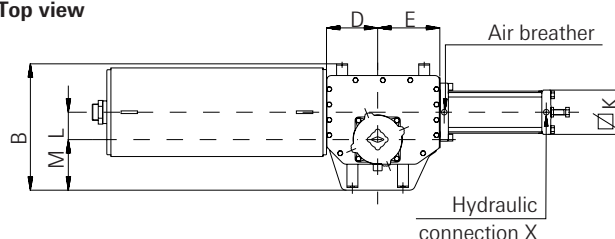

Dimensions in mm

Model	A	B	C	D	E	F	G	ØH	ØK	L	M	N	P	Q	Hydraulic connection		Weight (Kg)
															NPT X	NPT Y	
0.3-0150-100-CL	1346	319	314	136	151	765	581	210	125	70	119	70	35	279	1/2	-	84
0.3-0150-75-CL	1299	319	314	136	151	765	534	210	116	70	119	70	35	279	1/2	-	80
0.9-0200-135-CL	1533	413	353	160	190	857	676	265	160	80	170	83	50	303	1/2	-	166
0.9-0200-100-CL	1482	413	353	160	190	857	625	265	125	80	170	83	50	303	1/2	-	147
0.9-0350-135-CL	1586	413	383	160	190	910	676	325	160	80	170	83	80	303	1/2	-	200
0.9-0350-100-CL	1535	413	383	160	190	910	625	325	125	80	170	83	80	303	1/2	-	181
0.9-0400-135-CL	1520	413	383	160	190	844	676	325	160	80	170	83	80	303	1/2	-	195
0.9-0400-100-CL	1469	413	383	160	190	844	625	325	125	80	170	83	80	303	1/2	-	176
0.9-0700-135-CL	1547	413	383	160	190	871	676	325	160	80	170	83	80	303	1/2	-	217
0.9-0700-100-CL	1496	413	383	160	190	871	625	325	125	80	170	83	80	303	1/2	-	198
1.5-1100-175-CL	1726	493	451	187	227	963	763	415	196	100	185	100	108	343	1/2	-	368
1.5-1100-135-CL	1681	493	451	187	227	963	718	415	160	100	185	100	108	343	1/2	-	349
1.5-1200-175-CL	1825	473	431	187	227	1062	763	375	196	100	185	100	88	343	1/2	-	341
1.5-1200-135-CL	1780	473	431	187	227	1062	718	375	160	100	185	100	88	343	1/2	-	322
3-2000-175-CL	2721	586	453	285	330	1580	1141	415	196	160	215	106	102	351	1/2	-	646
3-2000-135-CL	2640	586	453	285	330	1580	1060	415	160	160	215	106	102	351	1/2	-	617
6-2500-200-CL	3181	740	466	327	379	1906	1275	383	230	185	260	140	52	414	-	3/4	884
6-2500-175-CL	3101	740	466	327	379	1906	1195	383	196	185	260	140	52	414	1/2	-	831
6-3800-200-CL	3413	740	547	327	379	2138	1275	545	230	185	260	140	133	414	-	3/4	1397
6-3800-175-CL	3333	740	547	327	379	2138	1195	545	196	185	260	140	133	414	1/2	-	1344
14-5400-280-CL	3386	838	698	376	435	2040	1346	545	360	200	295	193	150	548	-	3/4	2110
14-5400-235-CL	3350	838	698	376	435	2040	1310	545	Ø 340	200	295	193	150	548	-	3/4	2060
14-5400-200-CL	3370	838	698	376	435	2040	1330	545	230	200	295	193	150	548	-	3/4	2000
14-8300-280-CL	3460	838	698	376	435	2114	1346	545	360	200	295	193	150	548	-	3/4	2160
14-8300-235-CL	3424	838	698	376	435	2114	1310	545	Ø 340	200	295	193	150	548	-	3/4	2110
14-8300-200-CL	3444	838	698	376	435	2114	1330	545	230	200	295	193	150	548	-	3/4	2050
18-9600-280-CL	4092	940	749	427	495	2687	1405	580	360	230	340	196	184	565	-	3/4	2650
18-9600-235-CL	4111	940	749	427	495	2687	1424	580	Ø 340	230	340	196	184	565	-	3/4	2610
18-9800-280-CL	4092	940	749	427	495	2687	1405	580	360	230	340	196	184	565	-	3/4	3000
18-9800-235-CL	4111	940	749	427	495	2687	1424	580	Ø 340	230	340	196	184	565	-	3/4	2960

Notes

1. Dimensions and weights given are with oil and without optional bracket or adaptor flange
2. For mounting flange details see separate coupling dimensions leaflet
3. Add S to the model number to identify actuators with symmetric yoke (i.e. 0.3S-0150-100 CL)
4. The air breather in the head flange has the same NPT size of the hydraulic connection

Overall dimensions for spring to open actuators

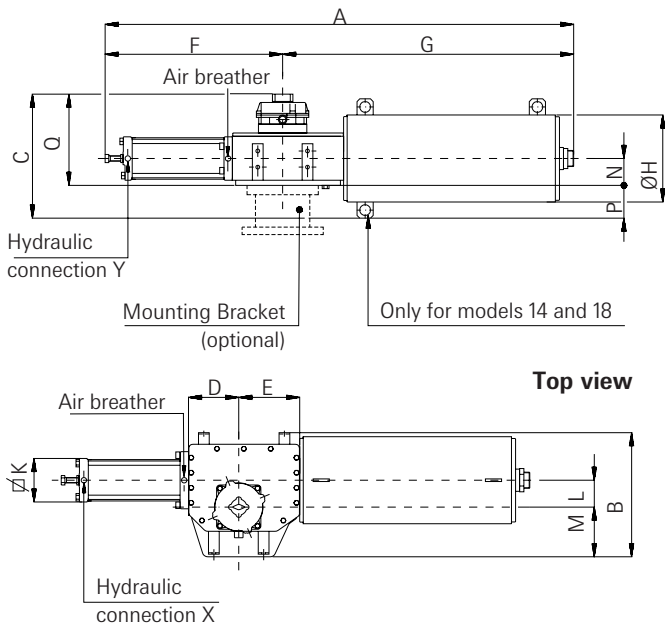

Dimensions in mm

Model	A	B	C	D	E	F	G	ØH	∅K	L	M	N	P	Q	Hydraulic connection		Weight (Kg)
															X	Y	
0.3-0150-100-OP	1346	319	314	136	151	566	780	210	125	70	119	70	35	279	1/2	-	84
0.3-0150-75-OP	1299	319	314	136	151	519	780	210	116	70	119	70	35	279	1/2	-	80
0.9-0200-135-OP	1533	413	353	160	190	646	887	265	160	80	170	83	50	303	1/2	-	166
0.9-0200-100-OP	1482	413	353	160	190	595	887	265	125	80	170	83	50	303	1/2	-	147
0.9-0350-135-OP	1586	413	383	160	190	646	940	325	160	80	170	83	80	303	1/2	-	200
0.9-0350-100-OP	1535	413	383	160	190	595	940	325	125	80	170	83	80	303	1/2	-	181
0.9-0400-135-OP	1520	413	383	160	190	646	874	325	160	80	170	83	80	303	1/2	-	195
0.9-0400-100-OP	1469	413	383	160	190	595	874	325	125	80	170	83	80	303	1/2	-	176
0.9-0700-135-OP	1547	413	383	160	190	646	901	325	160	80	170	83	80	303	1/2	-	217
0.9-0700-100-OP	1496	413	383	160	190	595	901	325	125	80	170	83	80	303	1/2	-	198
1.5-1100-175-OP	1726	493	451	187	227	723	1003	415	196	100	185	100	108	343	1/2	-	368
1.5-1100-135-OP	1681	493	451	187	227	678	1003	415	160	100	185	100	108	343	1/2	-	349
1.5-1200-175-OP	1825	473	431	187	227	723	1102	375	196	100	185	100	88	343	1/2	-	341
1.5-1200-135-OP	1780	473	431	187	227	678	1102	375	160	100	185	100	88	343	1/2	-	322
3-2000-175-OP	2721	586	453	285	330	1096	1625	415	196	160	215	106	102	351	1/2	-	646
3-2000-135-OP	2640	586	453	285	330	1015	1625	415	160	160	215	106	102	351	1/2	-	617
6-2500-200-OP	3181	740	466	327	379	1223	1958	383	230	185	260	140	52	414	-	3/4	884
6-2500-175-OP	3101	740	466	327	379	1143	1958	383	196	185	260	140	52	414	1/2	-	831
6-3800-200-OP	3413	740	547	327	379	1223	2190	545	230	185	260	140	133	414	-	3/4	1397
6-3800-175-OP	3333	740	547	327	379	1143	2190	545	196	185	260	140	133	414	1/2	-	1344
14-5400-280-OP	3387	838	698	376	435	1288	2099	545	360	200	295	193	150	548	-	3/4	2110
14-5400-235-OP	3351	838	698	376	435	1252	2099	545	Ø 340	200	295	193	150	548	-	3/4	2060
14-5400-200-OP	3371	838	698	376	435	1272	2099	545	230	200	295	193	150	548	-	3/4	2000
14-8300-280-OP	3461	838	698	376	435	1288	2173	545	360	200	295	193	150	548	-	3/4	2160
14-8300-235-OP	3425	838	698	376	435	1252	2173	545	Ø 340	200	295	193	150	548	-	3/4	2110
14-8300-200-OP	3445	838	698	376	435	1272	2173	545	230	200	295	193	150	548	-	3/4	2050
18-9600-280-OP	4092	940	749	427	495	1337	2755	580	360	230	340	196	184	565	-	3/4	2650
18-9600-235-OP	4111	940	749	427	495	1356	2755	580	Ø 340	230	340	196	184	565	-	3/4	2610
18-9800-280-OP	4092	940	749	427	495	1337	2755	580	360	230	340	196	184	565	-	3/4	3000
18-9800-235-OP	4111	940	749	427	495	1356	2755	580	Ø 340	230	340	196	184	565	-	3/4	2960

Notes

1. Dimensions and weights given are with oil and without optional bracket or adaptor flange
2. For mounting flange details see separate coupling dimensions leaflet
3. Add S to the model number to identify actuators with symmetric yoke (i.e. 0.3S-0150-100 OP)
4. The air breather in the head flange has the same NPT size of the hydraulic connection

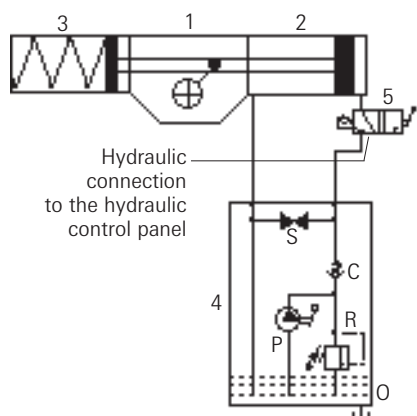

- 1. Scotch yoke mechanism
- 2. Hydraulic cylinder
- 3. Spring cartridge
- 4. Hydraulic manual override
- 5. Hydraulic manual selector
- S= Stop valve
- C= Check valve
- P= Hand pump
- R= Relief valve
- O= Oil tank

Emergency manual override

The OLGAS actuators can have an emergency manual override in addition to the local and/or remote control panel which controls the oil supplied by a power pack for the "normal" actuator operation.

The emergency manual override mounted on the actuator, consists of a hydraulic manual override and a hydraulic manual selector to choose the actuator "Normal operation", with oil supply from a power pack, or the "Emergency manual operation".

The compact hydraulic manual override consists of:

- hand pump to deliver oil from the tank to the actuator cylinder to control the actuator operation against the spring
- stop valve which allows the connection of the actuator cylinder to the oil tank to control the actuator operation by spring
- relief valve to prevent the oil pressure delivered by the hand pump from exceeding the maximum allowable value
- oil tank.

On request the emergency manual override can be included in the power pack.

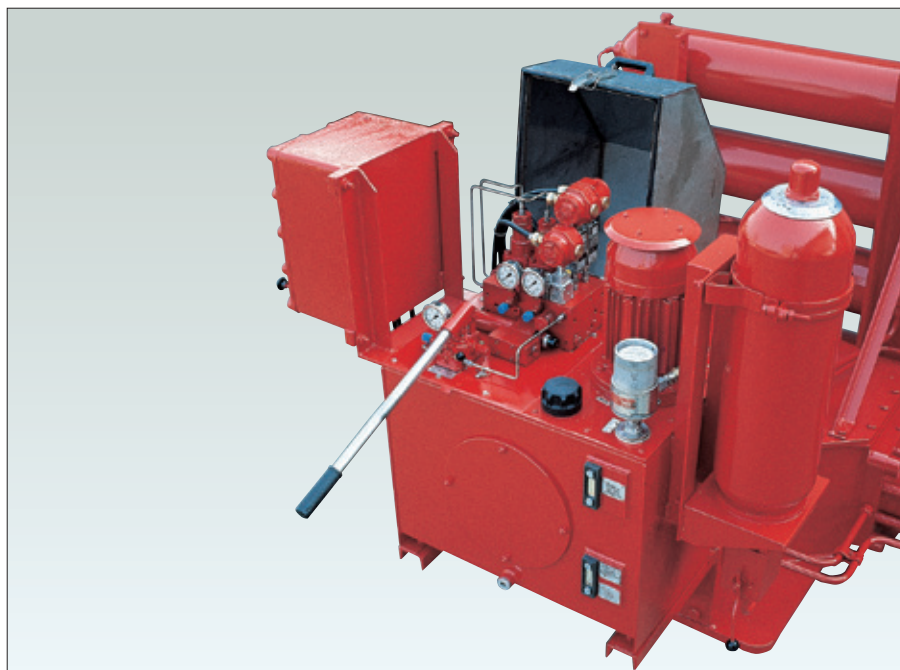
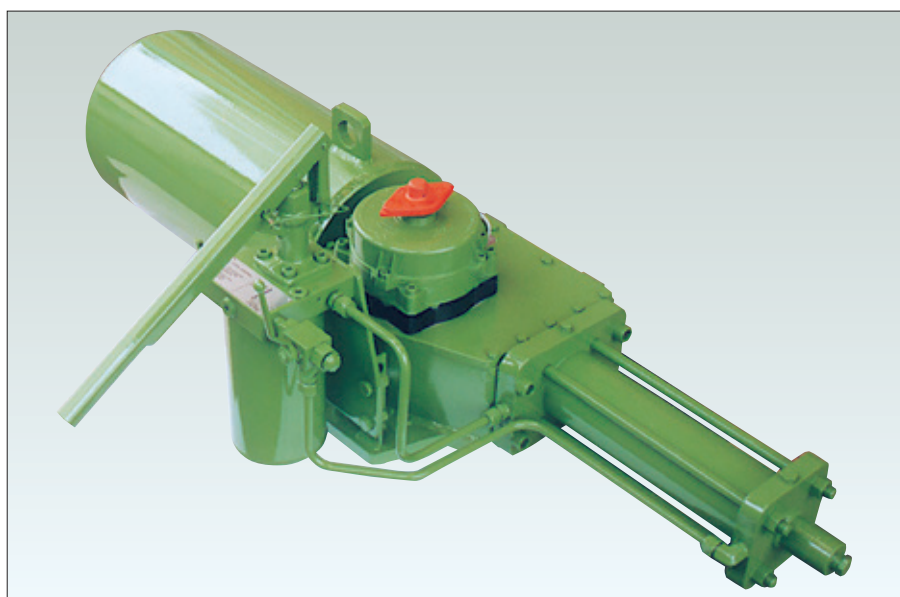

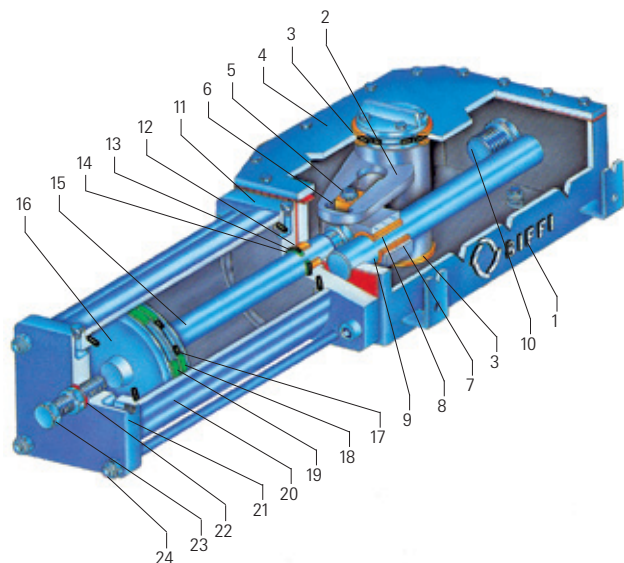
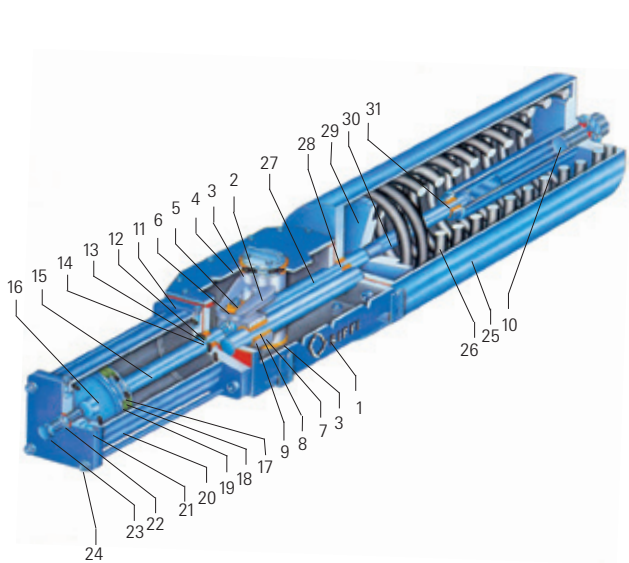

Materials specification

Item	Name	Material	Equivalence to U.S. standards
1	Housing	Carbon steel	ASTM A537 cl.1 +ASTM A283 gr D
2	Yoke	Carbon steel	API 5LX gr X52 (C<0.2%) +ASTM A537 cl.1
3	Yoke bushing	Bronze	ASTM B427 Alloy UNS No. C90800
4	Cover	Carbon steel	ASTM A283 gr D
5	Guide block pin	Alloy steel	AISI SAE 9840
6	Sliding block	Bronze	ASTM B427 Alloy UNS No C90800
7	Guide block	Carbon steel	ASTM A537 cl.1
8	Guide bar	Alloy steel (Chromium plated)	AISI SAE 9840
9	Guide block bushing	Steel +Bronze +Teflon	
10	Travel stop screw	Carbon steel	AISI SAE 1040
11	Cylinder head flange	Carbon steel	ASTM A283 gr D
12	Piston rod bushing	Steel +Bronze +Teflon	
13	Piston rod O-ring	Nitrile rubber	
14	Piston rod seal ring	Teflon	
15	Piston rod	Alloy steel (Chromium plated)	AISI SAE 9840
16	Piston	Carbon steel	ASTM A283 gr D
17	Piston O-ring	Nitrile rubber	
18	Piston seal ring	Teflon	
19	Piston guide sliding ring	Teflon +Graphite	
20	Cylinder tube	Carbon steel (Nickel plated)	API 5LX gr X52
21	End flange	Carbon steel	ASTM A283 gr D
22	Sealing washer	PVC	
23	Travel stop screw	Carbon steel	AISI SAE 1040
24	Tie rod	Alloy steel	AISI SAE 9840
25	Spring container	Carbon steel	ASTM A283 gr D + ASTM A106 gr B
26	Spring	Carbon steel	ASTM A29 gr 9254
27	Container rod	Alloy steel (Chromium plated)	AISI SAE 9840
28	Container rod bushing	Steel +Bronze +Teflon	
29	Spring thrust flange	Carbon steel	ASTM A283 gr D
30	Guide rod	Alloy steel (Chromium plated)	AISI SAE 9840
31	Guide rod bushing	Steel +Bronze +Teflon	

Scotch Yoke Mechanism

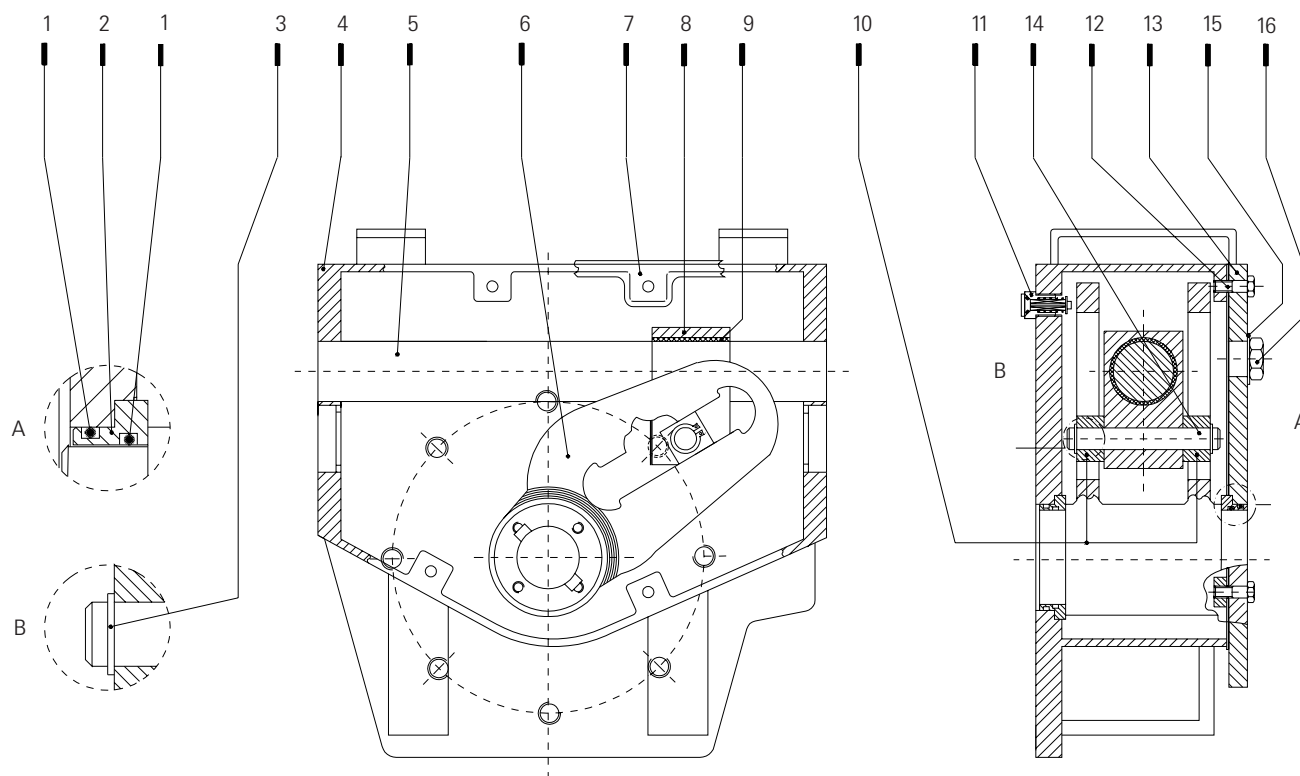

Materials specification

Item	Name	Material	Equivalence to U.S. standards	Q.ty
1	O-ring	NBR		4 •
2	Yoke bushing	Bronze	ASTM B427 Alloy UNS No. C90800	2
3	Retainer ring	Stainless steel	ASTM A479 Type 302	2
4	Housing	Carbon steel	ASTM A537 cl1+ASTM A283 gr D	1
5	Guide bar	Alloy steel	AISI SAE 9840 (chromium plated)	1
6	Yoke	Carbon steel	API 5LX gr X52 (C<0.2%)+ASTM A537 cl 1	1
7	Cover gasket	Fibre		1 •
8	Guide block	Carbon steel	ASTM A537 cl 1	1
9	Bushing	Steel+Bronze+Teflon		1
10	Sliding block	Bronze	ASTM B427 Alloy UNS No. C90800	2
11	Vent valve	Stainless steel	ASTM A479 Type 304	1 •
12	Screw	Carbon steel	AISI SAE 1040	16
13	Cover	Carbon steel	ASTM A283 gr D	1
14	Guide block pin	Alloy steel	AISI SAE 9840	1
15	Washer	Copper		1
16	Inspection plug	Carbon steel	AISI SAE 1040	1

• Recommended spare parts

Hydraulic cylinder for OLGA/OLGAS actuators

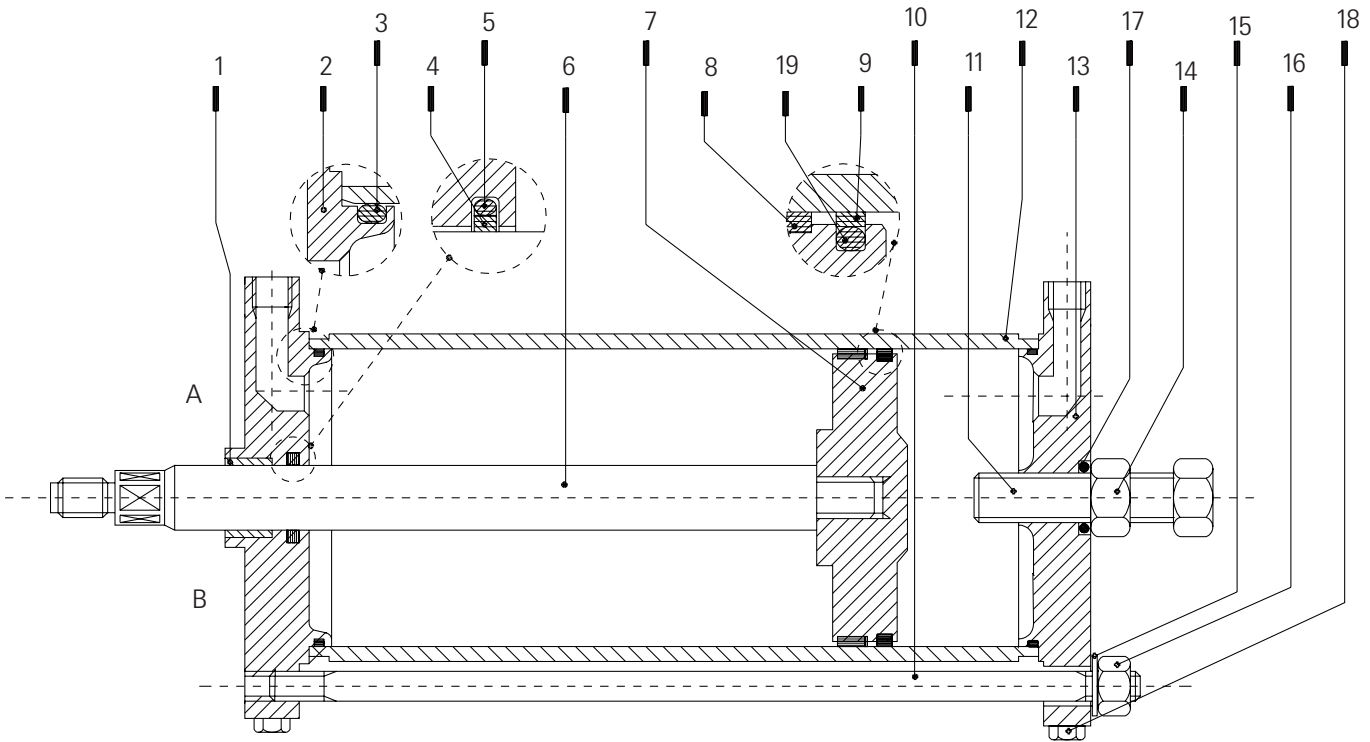

Materials specification

Item	Name	Material	Equivalence to U.S. standards	Q.ty
1	Piston rod bushing	Steel + Bronze + Teflon		1
2	Head flange	Carbon steel	ASTM A105	1
3	O-ring	NBR		2 •
4	Piston rod seal ring	Teflon + graphite		1 •
5	O-ring	NBR		1 •
6	Piston rod	Alloy steel (chromium plated)	AISI SAE 9840	1
7	Piston	Carbon steel	ASTM A105	1
8	Guide sliding ring for piston	Teflon + graphite		1 •
9	Piston seal ring	Teflon + graphite		1 •
10	Tie rod	Alloy steel	AISI SAE 9840	4
11	Travel stop screw	Carbon steel	AISI SAE 1040	1
12	Cylinder tube	Carbon steel (nickel plated)	API 5LX gr X52	1
13	End flange	Carbon steel	ASTM A105	1
14	Nut	Carbon steel	ASTM A194 gr 2	1
15	Spring washer	Carbon steel	AISI SAE 9840	4
16	Nut	Carbon steel	ASTM A194 gr 2	4
17	Sealing washer	PVC		1 •
18	Plug	Carbon steel	AISI SAE 1040	2
19	O-ring	NBR		1 •

• Recommended spare parts

Spring cartridge for OLGAS actuator

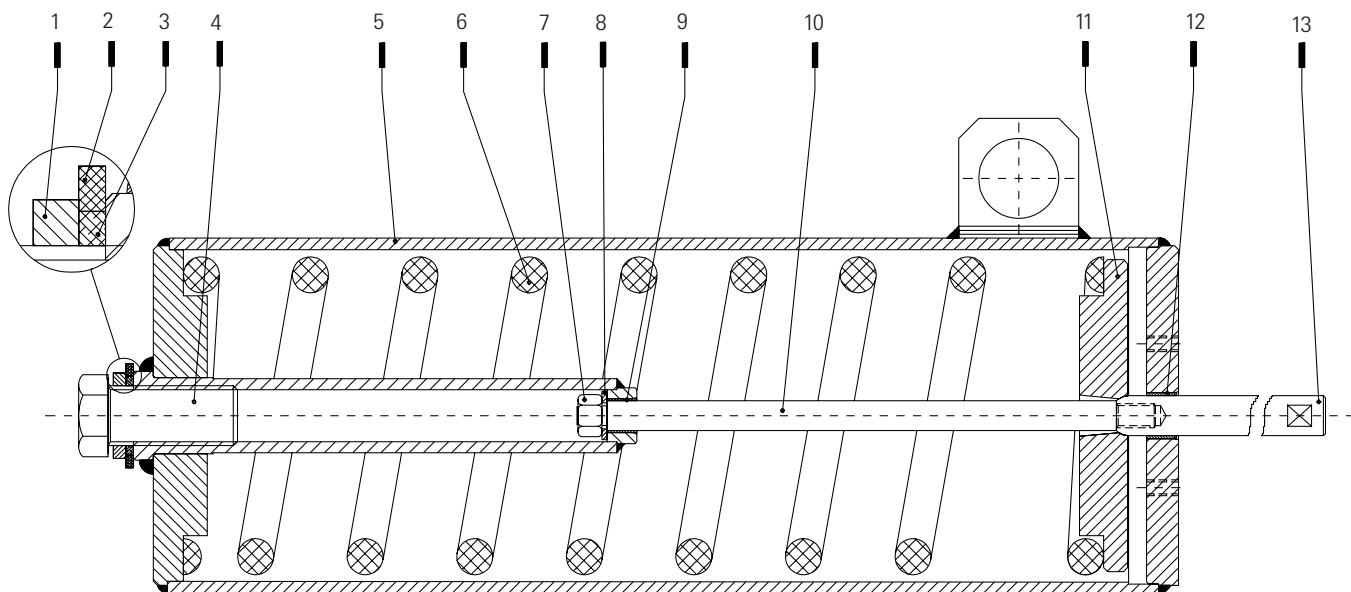

Materials specification				
Item	Name	Material	Equivalence to U.S. standards	Q.ty
1	Nut	Carbon steel	ASTM A194 gr 2	1
2	Washer	Carbon steel	AISI SAE 1040	1
3	Sealing washer	PVC		1 •
4	Travel stop screw	Carbon steel	AISI SAE 1040	1
5	Spring container	Carbon steel	ASTM A283 gr D + ASTM A106 gr B	1
6	Spring	Carbon steel	ASTM A29 gr 9254	1
7	Nut	Carbon steel	ASTM A194 gr 2	1
8	Shoulder washer	Carbon steel	AISI SAE 1040	1
9	Guide rod bushing	Steel + Bronze + Teflon		1
10	Guide rod	Alloy steel (chromium plated)	AISI SAE 9840	1
11	Spring thrust flange	Carbon steel	ASTM A283 gr D	1
12	Container rod bushing	Steel + Bronze + Teflon		1
13	Container rod	Alloy steel (chromium plated)	AISI SAE 9840	1

• Recommended spare parts

Main configuration assembly

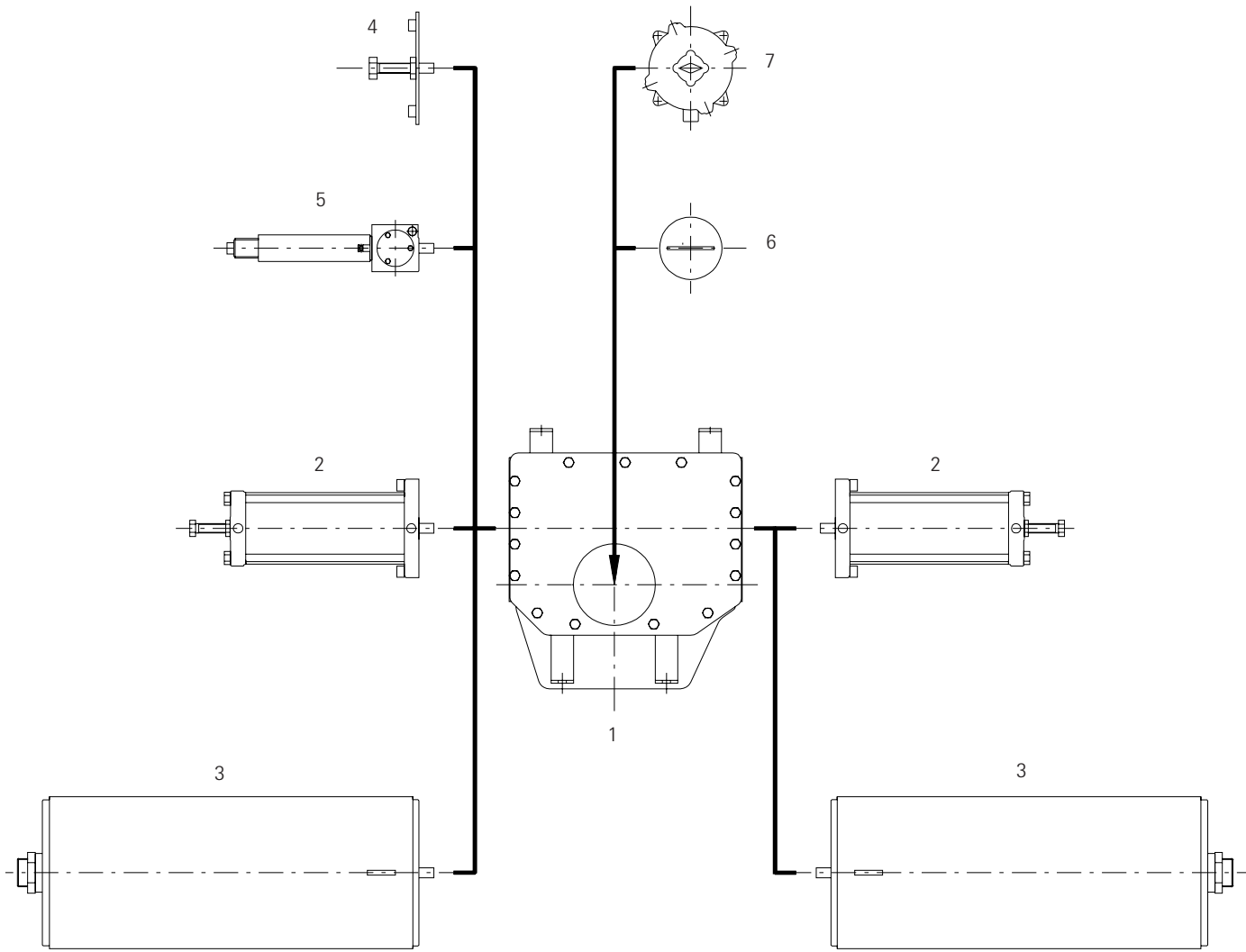

Item	Name
------	------

- 1 Scotch yoke mechanism
- 2 Hydraulic cylinder
- 3 Spring container
- 4 Travel stop screw
- 5 Manual override type "MSJ"
- 6 Local position indicator
- 7 Electric limit switch box

Valve data required

Break to open torque

Required torque to move the valve away from its closed position under the full differential pressure. This torque value must take into account the possible sticking effect which could affect the valve if it is closed for a long time.

Reseating torque

Required torque to close the valve under the full differential pressure.

Break to close torque

Required torque to move the valve away from its open position with maximum working pressure in the pipeline. This torque value can be high in the case of "double block and bleed" ball valves.

End to open torque

Required torque to fully open the valve.

Running torque

Required torque to actuate the valve in opening and in closing without differential pressure along the angular stroke except the fully open and fully closed positions where the required torques are those listed above.

Dynamic torque

Required torque to actuate the valve in opening under the medium flow through the valve. This torque value is high particularly on modulating service and when the medium speed and specific gravity are high.

The angular position where the dynamic torque occurs has to be defined.

Safety factor

It is essential to confirm if the above torque values include a safety factor. Depending on the valve application additional safety factors may have to be considered over and above those recommended.

Maximum allowable stem torque

Maximum torque the valve stem can withstand.

Valve stem dimensions

Operating conditions data required

- Supply medium pressure range (minimum, normal, maximum)
- Type of actuator: double acting or spring return to close or spring return to open
- On-Off or Modulating service
- Frequency of operation and required operating times

Actuator sizing general criteria

A safety factor must be included during sizing if not included in the figures supplied by the valve manufacturer.

The safety factor value has to be defined as a function of the valve type and size, of the working condition and of the operating time. The safety factor is usually included in the range from 1.2 to 1.5: higher values have to be employed in the case of extreme working conditions (for instance in case of low temperature, dirty and/or high viscosity medium, very infrequent operation, modulating service, short operating time).

The output torques values listed in the performance tables of actuators do not include a safety factor but are the minimum guaranteed torques.

Sizing of OLGA double acting actuators

OLGA actuators come in two versions, the standard one with canted scotch yoke mechanism and a special with symmetric scotch yoke mechanism.

Sizing of OLGA actuators with canted scotch yoke mechanism

Canted scotch yoke mechanism is utilised as a standard since its output torque characteristic is in general more suited to overcome the required valve torque throughout the 90° stroke. For actuator sizing the following comparisons between the valve data, including safety factors, and the actuator data have to be performed.

- Check that the actuator output torque to open at 0° (closed valve position), with minimum supply pressure, exceeds the valve "break to open torque" with maximum differential pressure
 - Check that the actuator output torque to close at 90° (open valve position), with minimum supply pressure, exceeds the valve "break to close torque" with maximum working pressure in the pipeline
 - Check that the actuator output torque at 45° (intermediate position), with minimum supply pressure, exceeds the valve "running torque"
 - Where a valve "dynamic torque" is present, check that this torque value is overridden by the actuator output torque at 45° (intermediate position), with minimum supply pressure.
- For a more accurate sizing BIFFI should be consulted
- Check that the valve stem dimensions are within the accepted values of the actuator selected size, unless an adaptor is required for other dimensional reasons
 - During operation the actuator provides, along its full travel, only a torque equal to the required valve torque. No problems will occur if the actuator output torque, as listed in the performance table, exceeds the valve maximum allowable stem torque. But if there is the possibility that the valve stops along its stroke, due to abnormal conditions, it is necessary to check that the actuator output torque, with the maximum supply pressure, does not exceed the valve maximum allowable stem torque and the actuator maximum operating torque

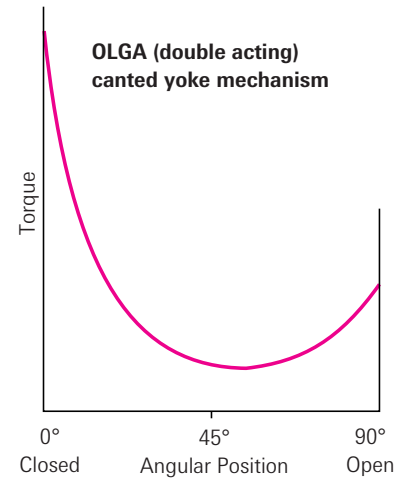

Sizing of OLGA actuators with symmetric scotch yoke mechanism

Symmetric scotch yoke mechanism is available on request as a special.

The torque output characteristics generated are more suited to applications where:

- the valve "break to close torque" is higher than the 50% of "break to open torque": this happens for example in the case of "double block and bleed" ball valves
- the valve "running torque" is higher than the 40% of "break to open torque" while utilising the canted yoke mechanism the actuator output torque is higher than the valve and/or actuator maximum allowable torque e.g. in the case of abnormal functioning or when the specifications require to consider this occurrence.

The checks that have to be performed for actuator sizing are the same as for canted scotch yoke mechanism.

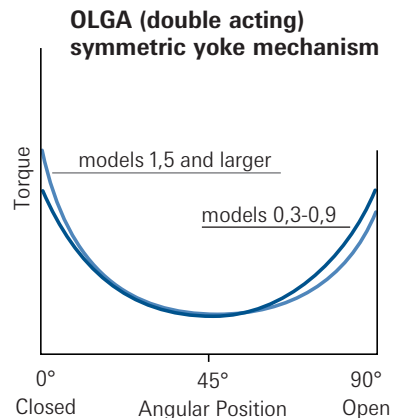

Sizing of OLGAS single acting actuators

OLGAS single acting spring return actuators can be supplied as spring to close (OLGAS-CL) or spring to open (OLGAS-OP).

Sizing of OLGAS-CL spring to close actuators with canted scotch yoke mechanism

The canted scotch yoke mechanism is utilised as a standard as the output torque characteristics, of both oil and spring operation, are in general more suited to overcome the required valve torque throughout the 90° stroke.

For actuator sizing the following comparisons between the valve data, including safety factors, and the actuator data have to be performed.

- Check that the "spring ending torque" of actuator exceeds the valve "reseating torque" with maximum differential pressure
- Check that the "oil starting torque" of actuator, with minimum supply pressure, exceeds the valve "break to open torque" with maximum differential pressure
- Check that the "spring starting torque" of actuator exceeds the valve "break to close torque" with maximum working pressure in the pipeline
- Check that the "oil ending torque" of actuator, with minimum supply pressure, exceeds the valve "end to open torque"
- Check that both the "spring running torque" and the "oil running torque", with minimum supply pressure, of the actuator exceed the valve "running torque"

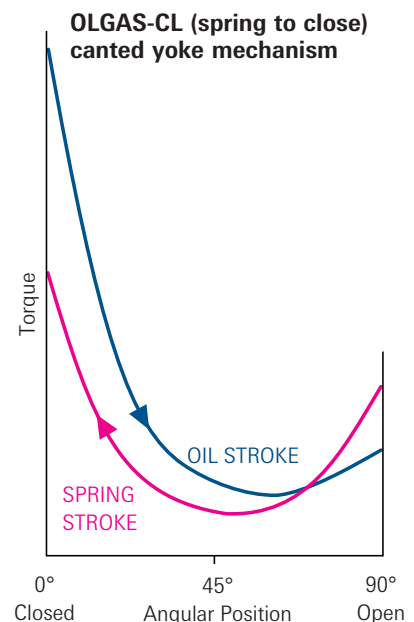

- Where a valve “dynamic torque” is present, check that it is overridden by the actuator “oil running torque”, with minimum supply pressure. For a more accurate sizing BIFFI should be consulted
- Check that the valve stem dimensions are within the accepted values of the actuator selected size, unless an adaptor is required for other dimensional reasons
- When required, since there is the possibility that the valve stops during its stroke due to abnormal conditions, it is necessary to check that the actuator “spring output torque” and the “oil output torque”, with maximum supply pressure, do not exceed the valve maximum allowable stem torque and the actuator maximum operating torque

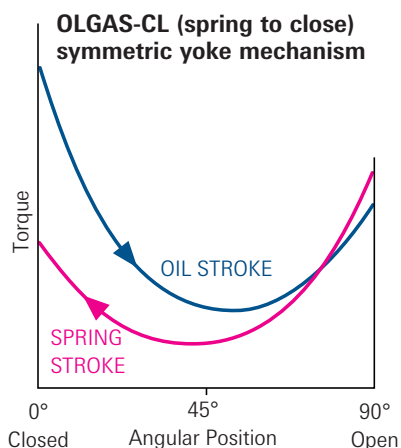

Sizing of OLGAS-CL spring to close actuators with symmetric scotch yoke mechanism

The symmetric scotch yoke mechanism is a special version that can be utilised when more suited to the required valve torque throughout the 90° stroke. E.g. when the valve “break to close torque” is higher than the “reseating torque”. The checks that have to be performed for actuator sizing are the same as for canted scotch yoke mechanism.

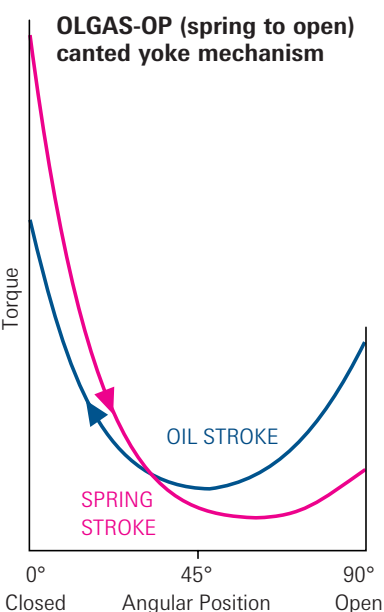

Sizing of OLGAS-OP spring to open actuators with canted scotch yoke mechanism

The canted scotch yoke mechanism is utilised as a standard as the output torque characteristics, of both oil and spring operation, are in general more suited to overcome the required valve torque throughout the 90° stroke.

For actuator sizing the following comparisons between the valve data, including safety factors, and the actuator data have to be performed.

- Check that the “oil ending torque” of actuator, with minimum supply pressure, exceeds the valve “reseating torque”, with maximum differential pressure
- Check that the “spring starting torque” of actuator exceeds the valve “break to open torque” with maximum differential pressure
- Check that the “oil starting torque” of actuator, with minimum supply pressure, exceeds the valve “break to close torque” with maximum working pressure in the pipeline
- Check that the “spring ending torque” of actuator exceeds the valve “end to open torque”
- Check that both the “spring running torque” and the “oil running torque”, with minimum supply pressure, exceed the valve “running torque”
- Where a valve “dynamic torque” is present, check that it is overridden by the actuator “spring running torque”. For a more accurate sizing BIFFI should be consulted
- Check that the valve stem dimensions are within the accepted values of actuator selected size, unless an adaptor is required for other dimensional reason
- When required, since there is the possibility that the valve stops during its stroke due to abnormal conditions, it is necessary to check that the actuator “spring output torque” and the “oil output torque”, with maximum supply pressure, do not exceed the valve maximum allowable stem torque and the actuator maximum operating torque

Sizing of OLGAS-OP spring to open actuators with symmetric scotch yoke mechanism

The symmetric scotch yoke mechanism is a special version that can be utilised when more suited to the required valve torque throughout the 90° stroke.

E.g. the valve “break to close torque” is higher than the “reseating torque”.

The checks that have to be performed for actuator sizing are the same as for canted yoke mechanism.

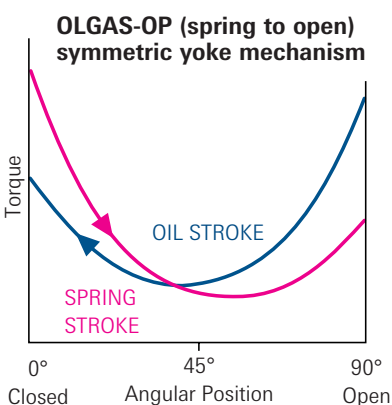

General

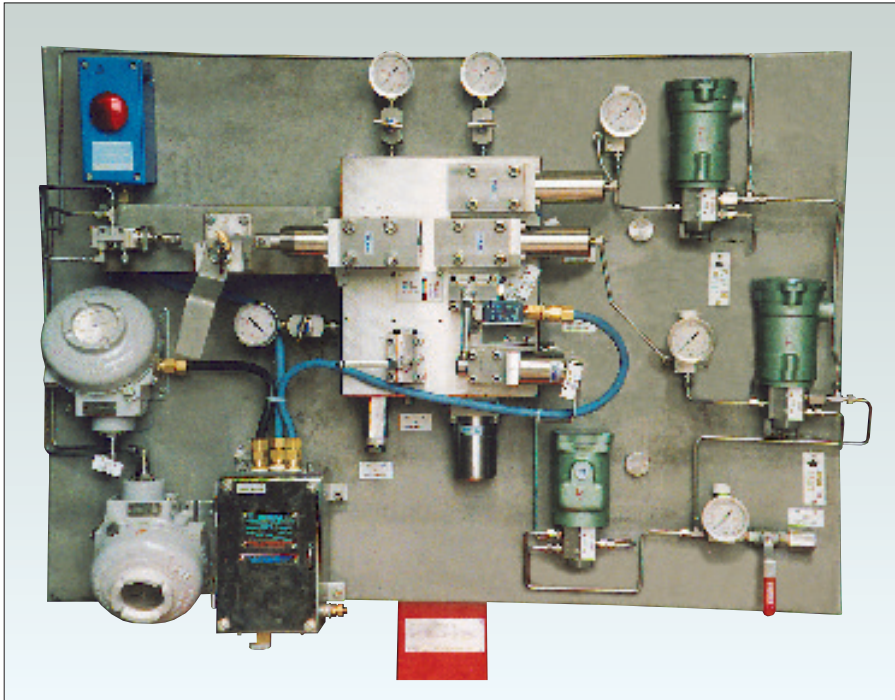

BIFFI has the ability to apply advanced engineering technology to the design and manufacture of hydraulic controls and accessories.

The experience and the knowledge acquired in the actuator industry allow BIFFI to meet with the highest requirements for control modes and operating conditions by correct selection of schematics, components, materials and protection treatment. The actuator service can be On-Off or Modulating. Actuator control can be local or remote by electric, or hydraulic signals.

The control system can include devices for automatic operation or stay put in case of emergency conditions (electric or hydraulic supply failure, high temperature, low or high pipeline pressure etc.).

The control systems have where is possible a "manifold design":

the components are connected by a flange to the manifold or assembled into the cavities machined into the manifold. This allows to have a very "compact" unit to reduce the number of connections by fittings and pipes and then to make the assembly and disassembly of each component easier, and to minimise the risk of oil leakage also in case the system undergoes strong vibrations.

Control systems can be supplied as panel mount or enclosed into a weatherproof cabinet.

Control systems can be supplied separate or assembled onto the actuator.

The actuator housing has dedicated supports for the mounting of control systems and accessories.

Main components of the control system

- Stop valves, needle valves, check valves
- Oil filter (bypass, visual and/or electric clogging indication on request) Filter element type and filtration degree depending on working conditions
- Bladder-type or piston-type accumulators ISPEL and TÜV stamped. Accumulators in accordance with different codes on request. Nitrogen back-up bottles for transfer barrier accumulators
- Solenoid valves, manual valves, hydraulic or pneumatic pilot valves
- Electro hydraulic proportional valves
- Electro hydraulic servovalves
- Electronic solenoid valve drivers for modulating service
- Dump valves, flow regulators, relief valves
- Dual pilot operated check valves
- Pressure gauges
- Hydraulic manifold
- Electric pressure switches
- Terminal enclosures

Features for on-off service

The standard components of hydraulic control systems have carbon steel or cast iron bodies. Stainless steel versions can be supplied.

- The standard components of hydraulic control systems are proper to operate with hydraulic mineral oil containing the necessary additives (anti-wear, anti-frothing, anti-oxidation agents). Special versions for fire resistant fluids
- The standard directional control valves are spool type. Poppet type (no leakage) valves are available
- Solenoid valves, flow regulators, relief valves, dump valves can be cartridge-type and assembled into the manifold cavities
- The electric component enclosures can have explosionproof and/or weatherproof protection. The explosionproof enclosures are in accordance with CENELEC Standards EN 50014 and EN 50018. Enclosures in accordance with UL or CSA Standards can be supplied. Components suitable for use in intrinsically safe circuits are available
- Terminals enclosures with increased safety protection are available
- The hydraulic connections are in carbon steel pipe and fittings as standard; stainless steel can be supplied on request
- Standard weatherproof cabinets for control systems are in carbon steel. Stainless steel can be supplied on request

Features for modulating service

A very important application for hydraulic actuators is modulating service. This is a frequent application in power plants, platforms, on ships, docks, chemical plants and, more generally, in industrial plants on steam, water, oil and gas lines, where it is necessary to regulate the flow of a fluid inside a pipe. Modulating actuators are also often used for quick emergency operation: closing (stop valve) or opening (vent valve, by-pass valve). This application is especially frequent on adduction lines for steam or gas to the turbine and for water to the condenser, where it is necessary for the valve to operate in a very short time in case of emergency.

The experience and knowledge Biffi acquired in the field of modulating actuators satisfy the Customers' strictest specifications and the severest working conditions through suitable calculation procedures, a correct selection of functional schematics, components, materials and protection treatments.

The hydraulic actuators utilized for modulating service can either be double acting (OLGA and OLGA/H) or spring return (OLGAS and OLGAS/H). Spring return actuators are generally utilized when quick emergency operation is necessary.

Control systems classification

The hydraulic control systems used for modulating actuators can be classified according to three basic types:

• Step by step

The hydraulic unit controlling the actuator movement consists in poppet-type solenoid valves mounted in a manifold. The actuator has two operation speed possibilities: "high speed" when the error is high, "low speed" when the error is small.

This avoids all hunting problems. Both "high" and "low" speed are adjustable by way of flow regulators in the manifold. An electronic control panel, especially designed by BIFFI, compares the valve position signal with the reference signal coming from the process regulator and, according to the the position error, operates the relevant solenoid valves for actuation and speed selection.

The "step-by-step" control system is generally used in case the modulating service is neither continuous nor heavy. The system is simple, requiring no high oil filtering degree and no supply oil flow while keeping the valve in the requested modulating position, because the solenoid valves are poppet-type (with no oil drain).

• By proportional valve

The actuator movement is controlled by a proportional valve the features of which are defined according to the requested performance and the applicable Customers' specifications (orifice dimensions, number of solenoids, integral transducer, shape of spool). The proportional valve is controlled by a suitable electronic card according to the electric control signal coming from the positioner and to the electric feed-back signal of the valve spool transducer. Generally BIFFI also supplies the electronic positioner controlling the actuator operation by way of the proportional valve and its electronic driver. The positioner compares the electric control signal coming from the plant regulator with the electric signal given by the valve position transmitter mounted on the actuator, and sends suitable input signals to the proportional valve electronic driver.

• By servo-valve

The actuator movement is controlled by a servo-valve the features of which are defined according to the requested performance and the applicable Customers' specifications (orifice dimensions, number of coils, type of feed-back).

The servo-valve controls actuator operation in accordance with the electric control signal coming from the positioner. BIFFI can also supply an electronic positioner to control actuator operation by comparing the electric control signal coming from the plant regulator with the electric signal coming from the valve position transmitter mounted on the actuator.

Integration with electronics

The vast and long experience in the field of electronic control units (positioners) and signal units (position transmitters) for modulating actuators allows BIFFI to meet with the highest requirements for control modes and operating conditions through the correct selection of schematics, components and materials. The electronic units are especially designed and manufactured for "on field" service in the severest conditions (low and/or high ambient temperature, vibrations, aggressive atmosphere, peculiar electric supply with special values and variation range).

For this reason high-performance and special construction electronic components are utilized, which are assembled in accordance with procedures ensuring perfect functioning in the severest working conditions on field. The use of microprocessors and digital techniques for positioning units allows to supply the positioner/actuator assembly with the possibility for otherwise impossible performances.

It increases positioning precision since it is possible to optimize speed control, to define the frequency response, to program the acceleration and deceleration ramps, to more efficiently select the type of position regulator most suitable to the service (P or PI or PID). Using a microprocessor allows to control the actuator by way of a digital communication serial line or Fieldbus, and also allows connection to an auxiliary computer for start-up adjustments and routine operational tests. It is also possible to use an IR remote control. The system also allows fine defect diagnostics, which will definitely ease maintenance operations and permit to plan a preventive maintenance of the unit with a view to the "intelligent actuator" more and more Customers now require.

Furthermore - using microprocessors allows the acquisition, processing and storage of other plant process data which do not depend on the actuator (e.g., pressure, temperature, etc.) but are measured locally, and their re-transmission to the central control unit.

BIFFI's respect for the severest Customers' specifications gave way to the development of a deep knowledge of all protection methods by way of galvanic separators, insulators, transient suppressors. The electrical components can be supplied either weatherproof or explosionproof, in accordance with the norms specified in the plant.

General

BIFFI has the ability to apply advanced engineering technology to the design and manufacture of hydraulic power packs, in order to meet with the highest requirements for operating modes and working conditions by a correct selection of schematics, components, materials and protection treatment. The energy supply for the power pack operation can be electric (direct current or alternate current) and/or pneumatic (low pressure or high pressure).

Hand pump manual override available on request for oil supply to the actuator in case of energy supply failure.

The power pack components can be supplied panel mounted or enclosed into a weatherproof cabinet. Sunshade is also available on request. Power pack can be supplied separate or assembled onto the actuator (if the dimensions and the weight allow so).

Main components of the power pack

- Oil tank with filler cap and drain plug
- Visual oil level indicator
- Electric level switch
- Electric thermostat
- Suction oil filters
- Delivery oil filters (bypass, visual and/or electric clogging indicator on request). Filter element type and filtration degree depending on working conditions
- Hydraulic rotating pumps
- Electric or pneumatic motors
- Pneumo-hydraulic pressure intensifier
- Hand pump, directional control valve
- Relief valves, flow regulators, check valves
- Stop valves, needle valves
- Pressure gauges
- Hydraulic manifold
- Bladder type or piston type accumulators ISPESEL and TÜV stamped. Accumulators in accordance with different codes on request. Nitrogen back-up bottles for transfer barrier accumulators
- Electric pressure switches
- Electric control panel
- Terminals enclosure

Features

- The standard oil tank is in carbon steel or aluminium (small sizes). Stainless steel versions can be supplied
- The standard rotating pumps are external gear type with aluminium body (cast iron version can be supplied). For higher working pressure and/or to have variable displacement vane pumps and radial or axial piston pumps are available
- Standard components of power packs are proper to operate with hydraulic mineral oil containing the necessary additives (anti-wear, anti-frothing, anti-oxidation agents). Special versions for fire resistant fluids
- Valve bodies and manifold are in carbon steel or cast iron. Stainless steel versions can be supplied
- Relief valves, flow regulators, check valves, stop valves can be cartridge type and assembled into the manifold cavities
- The electric components enclosures can have explosionproof and/or weatherproof protection. The explosionproof enclosures are in accordance with CENELEC Standards EN 50014 and EN 50018. Enclosures in accordance with UL or CSA Standards can be supplied. Components suitable for use in intrinsically safe circuits are available
- Terminal enclosures with increased safety protection are available
- The hydraulic connections are in carbon steel pipe and fittings as standard; stainless steel can be supplied on request
- Standard weatherproof cabinets are in carbon steel; stainless steel can be supplied on request

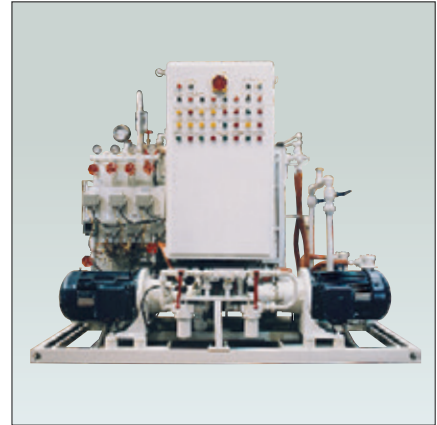

Mounting holes of housing

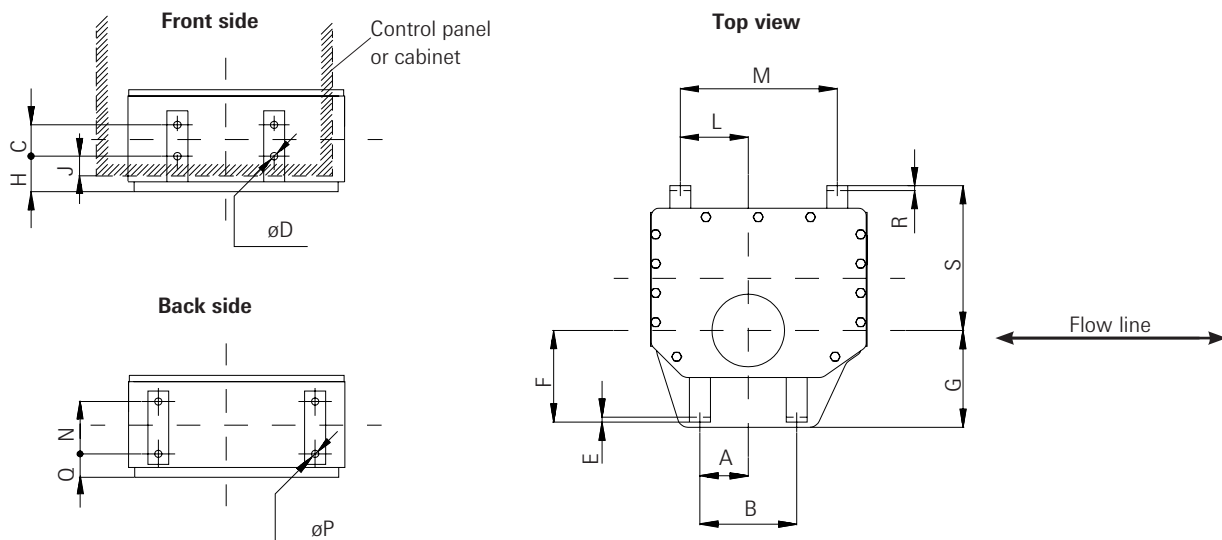

Dimensions in mm																
Model	A	B	C	ϕD	E	F	G	H	J	L	M	N	ϕP	Q	R	S
0.3	77.5	155	60	14	5	113	119	37	12	92	200	60	14	36	5	200
0.9	92.5	185	60	14	5	155	170	61	35	85	200	60	14	48	5	243
1.5	92.5	185	60	14	5	175	185	62	35	130	300	100	14	45	5	284
3	117.5	235	85	23	8	203	215	57	25	230	500	100	14	54	5	371
6	137	455	115	23	8	248	260	59	22	224	500	100	14	87	8	480
14	315	630	200	27	10	227	330	97	55	220	500	170	27	99	8	543
18	315	630	200	27	10	235	340	72	32	306	680	215	27	80	10	600
32	315	630	200	27	10	385	395	72	32	414	890	215	27	149	10	660
50	387.5	860	250	30	12	372	387	77	35	473	1030	215	27	163	10	1072

Mounting holes of cover and yoke

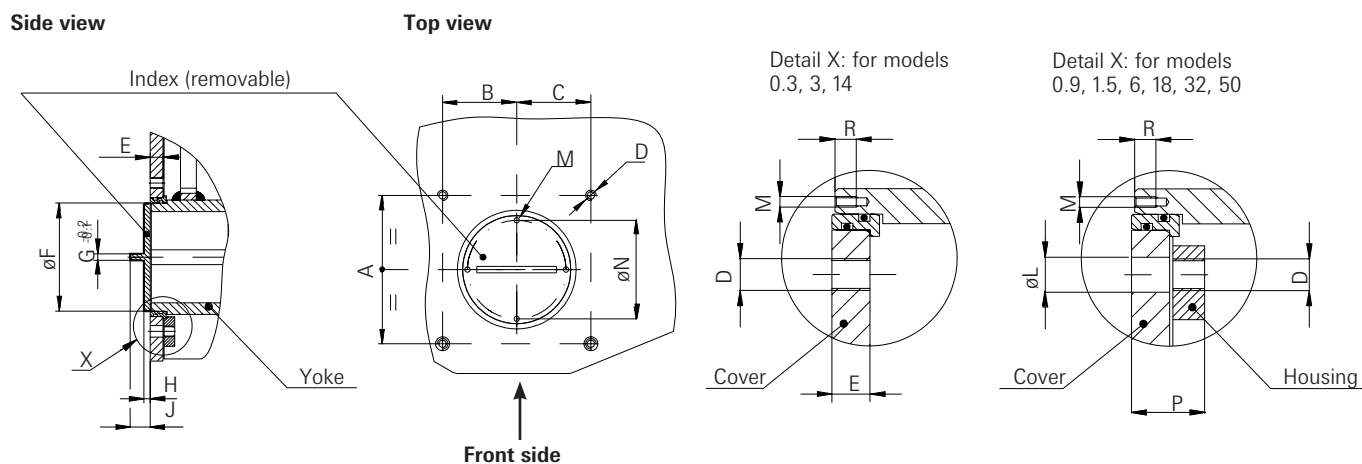

Dimensions in mm															
Model	A	B	C	D	E	ϕF	G	H	J	ϕL	M	ϕN	P	R	
0.3	140	70	70	No. 4 x M 10	10	84	6	6	19	-	No. 4 x M 4	76	-	7	
0.9	140	70	70	No. 4 x M 10	12	102	6	6	19	11	No. 4 x M 4	93	22	7	
1.5	140	70	70	No. 4 x M 10	12	133	6	6	19	11	No. 4 x M 5	122	22	7	
3	160	127	136	No. 4 x M 16	12	184	6	6	19	-	No. 4 x M 6	171	-	10	
6	160	127	136	No. 4 x M 16	13	232	6	6	19	16.5	No. 4 x M 6	216	30	10	
14	160	127	136	No. 4 x M 16	16	232	6	6	19	-	No. 4 x M 6	216	-	10	
18	314	109	109	No. 4 x M 16	18	255	6	6	16	16.5	No. 4 x M 6	240	35	10	
32	314	109	109	No. 4 x M 16	16	265	6	6	16	16.5	No. 4 x M 6	250	33	10	
50	280.6	138.5	138.5	No. 4 x M 20	18	295	6	6	16	20.5	No. 4 x M 6	278	46	10	

The index is shown for actuator in end position (fully open or closed)